



**THE DATASHEET OF  
CD54HC238F3A**



# CDx4HC138, CDx4HCT138, CDx4HC238, CDx4HCT238 High-Speed CMOS Logic 3- to 8-Line Decoder/Demultiplexer Inverting and Noninverting

## 1 Features

- Select one of eight data outputs:
  - Active low for '138
  - Active high for '238
- I/O port or memory selector
- Three enable inputs to simplify cascading
- Typical propagation delay of 13 ns at  $V_{CC} = 5\text{ V}$ ,  $C_L = 15\text{ pF}$ ,  $T_A = 25^\circ\text{C}$
- Fanout (over temperature range)
  - Bus driver outputs: 15 LSTTL loads
  - Standard outputs: 10 LSTTL loads
- Wide operating temp range:  $-55^\circ\text{C}$  to  $125^\circ\text{C}$
- Balanced propagation delay and transition times
- Significant power reduction compared to LSTTL logic ICs
- HC types
  - 2 V to 6 V operation
  - High noise immunity:  $N_{IL} = 30\%$ ,  $N_{IH} = 30\%$  of  $V_{CC}$  at  $V_{CC} = 5\text{ V}$
- HCT types
  - 4.5-V to 5.5-V operation
  - Direct LSTTL input logic compatibility,  $V_{IL} = 0.8\text{ V (Max)}$ ,  $V_{IH} = 2\text{ V (Min)}$
  - CMOS input compatibility,  $I_I \leq 1\mu\text{A}$  at  $V_{OL}$ ,  $V_{OH}$

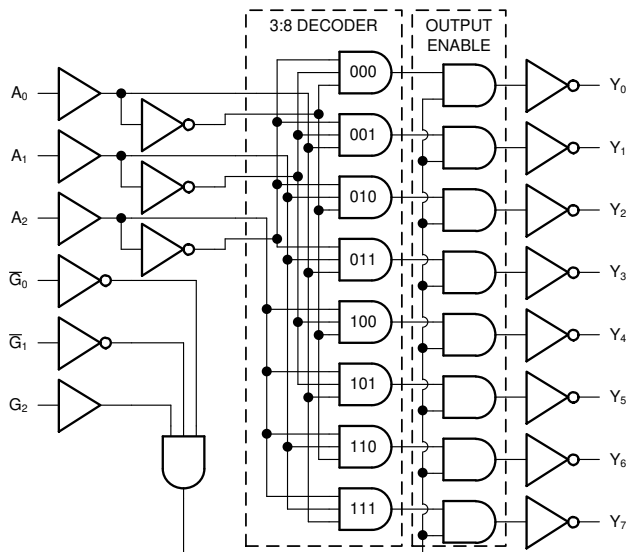

Functional Block Diagram '138

## 2 Description

The CDx4HC(T)138 and '238 are three to eight decoders with one standard output strobe ( $G_2$ ) and two active low output strobes ( $\overline{G}_1$  and  $\overline{G}_0$ ). When the outputs are gated by any of the strobe inputs, they are all forced into the high state. When the outputs are not disabled by the strobe inputs, only the selected output is low while all others are high.

The CDx4HC(T)238 is a three to eight decoder with one standard output strobe ( $G_2$ ) and two active low output strobes ( $\overline{G}_1$  and  $\overline{G}_0$ ). When the outputs are gated by any of the strobe inputs, they are all forced into the low state. When the outputs are not disabled by the strobe inputs, only the selected output is high while all others are low.

### Device Information

PART NUMBER	PACKAGE <sup>(1)</sup>	BODY SIZE (NOM)
CD74HC138E	PDIP (16)	25.40 mm × 6.35 mm
CD74HCT138E	PDIP (16)	25.40 mm × 6.35 mm
CD74HCT238E	PDIP (16)	25.40 mm × 6.35 mm
CD74HC138M	SOIC (16)	9.90 mm × 3.90 mm
CD74HCT238M	SOIC (16)	9.90 mm × 3.90 mm
CD74HC238NS	SO (16)	10.20 mm × 5.30 mm
CD74HC238PW	TSSOP (16)	5.00 mm × 4.40 mm
CD74HCT238PW	TSSOP (16)	5.00 mm × 4.40 mm
CD54HC138F	CDIP (16)	21.34 mm × 6.92 mm
CD54HCT138F	CDIP (16)	21.34 mm × 6.92 mm
CD54HCT238F	CDIP (16)	21.34 mm × 6.92 mm

- (1) For all available packages, see the orderable addendum at the end of the data sheet.



## Table of Contents

<b>1 Features</b> .....	1	<b>7.3 Device Functional Modes</b> .....	10
<b>2 Description</b> .....	1	<b>8 Power Supply Recommendations</b> .....	11
<b>3 Revision History</b> .....	2	<b>9 Layout</b> .....	11
<b>4 Pin Configuration and Functions</b> .....	3	9.1 Layout Guidelines.....	11
<b>5 Specifications</b> .....	4	<b>10 Device and Documentation Support</b> .....	12
5.1 Absolute Maximum Ratings.....	4	10.1 Documentation Support.....	12
5.2 Recommended Operating Conditions.....	4	10.2 Receiving Notification of Documentation Updates..	12
5.3 Thermal Information.....	4	10.3 Support Resources.....	12
5.4 Electrical Characteristics.....	5	10.4 Trademarks.....	12
5.5 Switching Characteristics <sup>(2)</sup> .....	6	10.5 Electrostatic Discharge Caution.....	12
<b>6 Parameter Measurement Information</b> .....	7	10.6 Glossary.....	12
<b>7 Detailed Description</b> .....	8	<b>11 Mechanical, Packaging, and Orderable Information</b> .....	12
7.1 Overview.....	8		
7.2 Functional Block Diagram.....	8		

### 3 Revision History

NOTE: Page numbers for previous revisions may differ from page numbers in the current version.

Changes from Revision I (August 2004) to Revision J (November 2021)	Page
• Updated the numbering, formatting, tables, figures, and cross-references throughout the document to reflect modern datasheet standards.....	1
• Updated pin names to match current TI naming conventions. E <sub>3</sub> is now G <sub>2</sub> , $\bar{E}_2$ is now $\bar{G}_1$ , $\bar{E}_1$ is now $\bar{G}_0$ ....	1

## 4 Pin Configuration and Functions

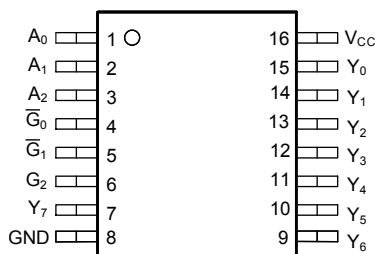

**J, N, D, NS, or PW package  
16-Pin CDIP, PDIP, SOIC, SO, or TSSOP  
Top View**

### Pin Functions

PIN		I/O <sup>(1)</sup>	DESCRIPTION
SOIC or TSSOP NO.	NAME		
1	A <sub>0</sub>	I	Address select 0
2	A <sub>1</sub>	I	Address select 1
3	A <sub>2</sub>	I	Address select 2
4	$\overline{G}_0$	I	Output strobe 0, active low
5	$\overline{G}_1$	I	Output strobe 1, active low
6	G <sub>2</sub>	I	Output strobe 2
7	Y <sub>7</sub>	O	Output 7
8	GND	—	Ground
9	Y <sub>6</sub>	O	Output 6
10	Y <sub>5</sub>	O	Output 5
11	Y <sub>4</sub>	O	Output 4
12	Y <sub>3</sub>	O	Output 3
13	Y <sub>2</sub>	O	Output 2
14	Y <sub>1</sub>	O	Output 1
15	Y <sub>0</sub>	O	Output 0
16	V <sub>CC</sub>	—	Positive supply

(1) Signal Types: I = Input, O = Output, I/O = Input or Output.

## 5 Specifications

### 5.1 Absolute Maximum Ratings

over operating free-air temperature range (unless otherwise noted)<sup>(1)</sup>

		MIN	MAX	UNIT
V <sub>CC</sub>	Supply voltage	-0.5	7	V
I <sub>IK</sub>	Input clamp diode current	For V <sub>I</sub> < 0.5V or V <sub>I</sub> > V <sub>CC</sub> + 0.5V		±20 mA
I <sub>OK</sub>	Output clamp diode current	For V <sub>O</sub> < -0.5V or V <sub>O</sub> > V <sub>CC</sub> + 0.5V		±20 mA
I <sub>O</sub>	Output source or sink current per output pin	For V <sub>O</sub> > -0.5V or V <sub>O</sub> < V <sub>CC</sub> + 0.5V		±25 mA
	Continuous current through V <sub>CC</sub> or GND			±50 mA
T <sub>J</sub>	Junction temperature			150 °C
T <sub>stg</sub>	Storage temperature range	-65	150	°C
	Lead temperature (Soldering 10s) (SOIC - Lead Tips Only)			300 °C

- (1) Stresses beyond those listed under *absolute maximum ratings* may cause permanent damage to the device. These are stress ratings only and functional operation of the device at these or any other conditions beyond those indicated under *recommended operating conditions* is not implied. Exposure to absolute-maximum-rated conditions for extended periods may affect device reliability.

### 5.2 Recommended Operating Conditions

		MIN	MAX	UNIT	
V <sub>CC</sub>	Supply voltage range	HC types	2	6	V
		HCT types	4.5	5.5	
V <sub>I</sub>	Input voltage	0	V <sub>CC</sub>	V	
V <sub>O</sub>	Output voltage	0	V <sub>CC</sub>	V	
t <sub>t</sub>	Input rise and fall time	V <sub>CC</sub> = 2V	1000		ns
		V <sub>CC</sub> = 4.5V	500		
		V <sub>CC</sub> = 6V	400		
T <sub>A</sub>	Temperature range	-55	125	°C	

### 5.3 Thermal Information

THERMAL METRIC		CD74HC(T)138, CD74HC(T)238				UNIT
		N (PDIP)	D (SOIC)	NS (SOP)	PW (TSSOP)	
		16 Pins	16 Pins	16 Pins	16 Pins	
R <sub>θJA</sub>	Junction-to-ambient thermal resistance <sup>(1)</sup>	67	73	64	108	°C/W

- (1) For more information about traditional and new thermal metrics, see the [Semiconductor and IC package thermal metrics](#) application report.

## 5.4 Electrical Characteristics

PARAMETER	TEST CONDITIONS <sup>(1)</sup>	V <sub>CC</sub> (V)	25°C			-40°C to 85°C		-55°C to 125°C		UNIT	
			MIN	TYP	MAX	MIN	MAX	MIN	MAX		
<b>HC TYPES</b>											
V <sub>IH</sub>	High-level input voltage		2	1.5		1.5		1.5		V	
			4.5	3.15		3.15		3.15		V	
			6	4.2		4.2		4.2		V	
V <sub>IL</sub>	Low-level input voltage		2		0.5		0.5		0.5	V	
			4.5		1.35		1.35		1.35	V	
			6		1.8		1.8		1.8	V	
V <sub>OH</sub>	High-level output voltage	I <sub>OH</sub> = -20 μA	2	1.9		1.9		1.9		V	
		I <sub>OH</sub> = -20 μA	4.5	4.4		4.4		4.4		V	
		I <sub>OH</sub> = -20 μA	6	5.9		5.9		5.9		V	
	High-level output voltage	I <sub>OH</sub> = -4 mA	4.5	3.98		3.84		3.7		V	
		I <sub>OH</sub> = -5.2 mA	6	5.48		5.34		5.2		V	
V <sub>OL</sub>	Low-level output voltage	I <sub>OL</sub> = 20 μA	2		0.1		0.1		0.1	V	
		I <sub>OL</sub> = 20 μA	4.5		0.1		0.1		0.1	V	
		I <sub>OL</sub> = 20 μA	6		0.1		0.1		0.1	V	
	Low-level output voltage	I <sub>OL</sub> = 4 mA	4.5		0.26		0.33		0.4	V	
		I <sub>OL</sub> = 5.2 mA	6		0.26		0.33		0.4	V	
I <sub>I</sub>	Input leakage current	V <sub>I</sub> = V <sub>CC</sub> or GND	6		±0.1		±1		±1	μA	
I <sub>CC</sub>	Supply current	V <sub>I</sub> = V <sub>CC</sub> or GND	6		8		80		160	μA	
<b>HCT TYPES</b>											
V <sub>IH</sub>	High-level input voltage		4.5 to 5.5	2			2		2	V	
V <sub>IL</sub>	Low-level input voltage		4.5 to 5.5		0.8		0.8		0.8	V	
V <sub>OH</sub>	High-level output voltage	I <sub>OH</sub> = -20 μA	4.5	4.4		4.4		4.4		V	
	High-level output voltage	I <sub>OH</sub> = -4 mA	4.5	3.98		3.84		3.7		V	
V <sub>OL</sub>	Low-level output voltage	I <sub>OL</sub> = 20 μA	4.5		0.1		0.1		0.1	V	
	Low-level output voltage	I <sub>OH</sub> = 4 mA	4.5		0.26		0.33		0.4	V	
I <sub>I</sub>	Input leakage current	V <sub>I</sub> = V <sub>CC</sub> and GND	5.5		±0.1		±1		±1	μA	
I <sub>CC</sub>	Supply current	V <sub>I</sub> = V <sub>CC</sub> and GND	5.5		8		80		160	μA	
ΔI <sub>CC</sub>	Additional supply current per input pin	A <sub>0</sub> - A <sub>2</sub> inputs held at V <sub>CC</sub> - 2.1 V	4.5 to 5.5		100	540		675		735	μA
		$\overline{G}_0$ and $\overline{G}_1$ inputs held at V <sub>CC</sub> - 2.1 V	4.5 to 5.5		100	450		562.5		612.5	μA
		G <sub>2</sub> input held at V <sub>CC</sub> - 2.1 V	4.5 to 5.5		100	360		450		490	μA

(1) V<sub>I</sub> = V<sub>IH</sub> or V<sub>IL</sub>, unless otherwise noted.

## 5.5 Switching Characteristics<sup>(2)</sup>

Input  $t_f = 6\text{ns}$ . (See [Parameter Measurement Information](#))

PARAMETER	TEST CONDITIONS	$V_{CC}$ (V)	25°C			-40°C to 85°C		-55°C to 125°C		UNIT		
			MIN	TYP	MAX	MIN	MAX	MIN	MAX			
<b>HC TYPES</b>												
$t_{pd}$	Address to output	$C_L = 50\text{pF}$	2		150		190		225	ns		
			4.5		13 <sup>(3)</sup>		38		45			
			6		26		33		38			
	Strobe $\overline{G}_0, \overline{G}_1, G_2$ to output HC/HCT 138	$C_L = 50\text{pF}$	2		150		190		265	ns		
			4.5		30		38		53			
			6		26		33		45			
$t_t$	Output transition time	$C_L = 50\text{pF}$	2		75		95		110	MHz		
			4.5		15		19		22			
			6		13		16		19			
$C_{pd}$	Power dissipation capacitance <sup>(1)</sup>	$C_L = 15\text{pF}$	5		67					pF		
$C_i$	Input capacitance					10		10		10	pF	
<b>HCT TYPES</b>												
$t_{pd}$	Address to output	$C_L = 50\text{pF}$	4.5		14 <sup>(3)</sup>		35		44		53	ns
	Strobe $G_2$ to output HC/HCT138	$C_L = 50\text{pF}$	4.5				35		44		53	ns
	Strobe $\overline{G}_0, \overline{G}_1$ to output HC/HCT238	$C_L = 15\text{pF}$	4.5				40		50		60	ns
$t_t$	Output transition time	$C_L = 15\text{pF}$	4.5				15		19		22	
$C_{pd}$	Power dissipation capacitance <sup>(1)</sup>	$C_L = 15\text{pF}$	5				67					pF
$C_i$	Input capacitance						10		10		10	pF

(1)  $C_{PD}$  is used to determine the dynamic power consumption, per gate.

(2) For details on power calculation, see [SCAA035B](#)

(3)  $C_L = 15\text{pF}$  and  $V_{CC} = 5$

## 6 Parameter Measurement Information

Phase relationships between waveforms were chosen arbitrarily. All input pulses are supplied by generators having the following characteristics:  $PRR \leq 1 \text{ MHz}$ ,  $Z_O = 50 \Omega$ ,  $t_f < 6 \text{ ns}$ .

For clock inputs,  $f_{max}$  is measured when the input duty cycle is 50%.

The outputs are measured one at a time with one input transition per measurement.

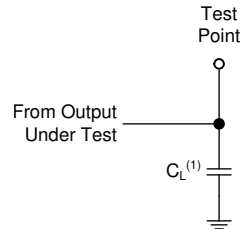

(1)  $C_L$  includes probe and test-fixture capacitance.

**Figure 6-1. Load Circuit for Push-Pull Outputs**

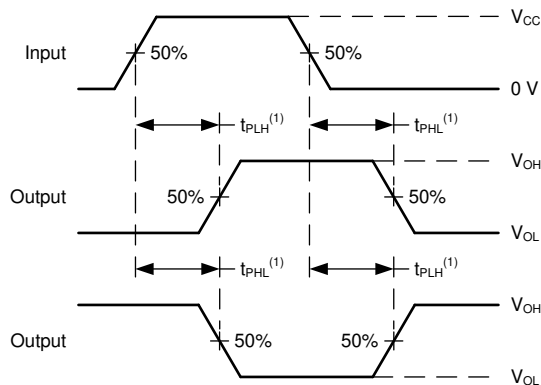

(1) The greater between  $t_{PLH}$  and  $t_{PHL}$  is the same as  $t_{pd}$ .

**Figure 6-2. Voltage Waveforms, Propagation Delays for Standard CMOS Inputs**

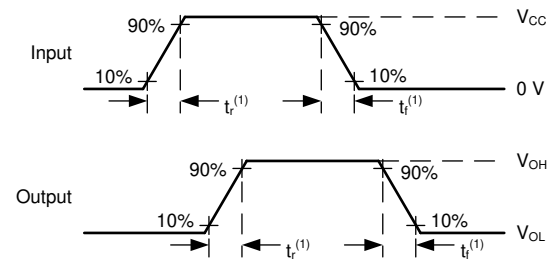

(1) The greater between  $t_r$  and  $t_f$  is the same as  $t_t$ .

**Figure 6-3. Voltage Waveforms, Input and Output Transition Times for Standard CMOS Inputs**

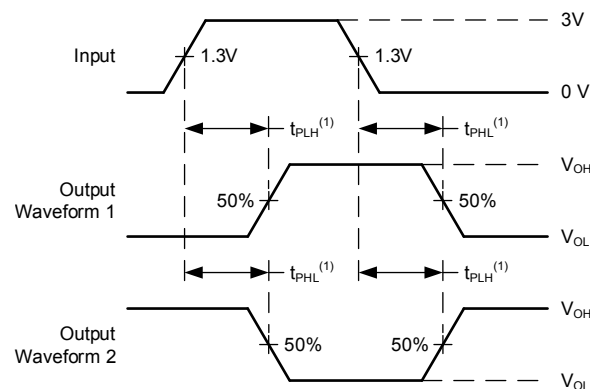

(1) The greater between  $t_{PLH}$  and  $t_{PHL}$  is the same as  $t_{pd}$ .

**Figure 6-4. Voltage Waveforms, Propagation Delays for TTL-Compatible Inputs**

## 7 Detailed Description

### 7.1 Overview

The CDx4HC(T)138 and '238 are high speed silicon gate CMOS decoders well suited to memory address decoding or data routing applications. They contain a single 3:8 decoder.

The CDx4HC(T)138 and '238 have three address select inputs ( $A_2$ ,  $A_1$ , and  $A_0$ ). The circuit functions as a normal one-of-eight decoder.

Three strobe inputs ( $G_2$ ,  $\overline{G}_1$  and  $\overline{G}_0$ ) are provided to simplify cascading and to facilitate demultiplexing. When any input strobe is active, all outputs are forced into the high state for the '138 function. When any input strobe is active, all outputs are forced into the low state for the '238 function.

The demultiplexing function is accomplished by first using the select inputs to choose the desired output, and then using one of the strobe inputs as the data input.

The outputs for the CDx4HC(T)138 are normally low when selected. The outputs for the CDxHC(T)238 are normally high when selected.

### 7.2 Functional Block Diagram

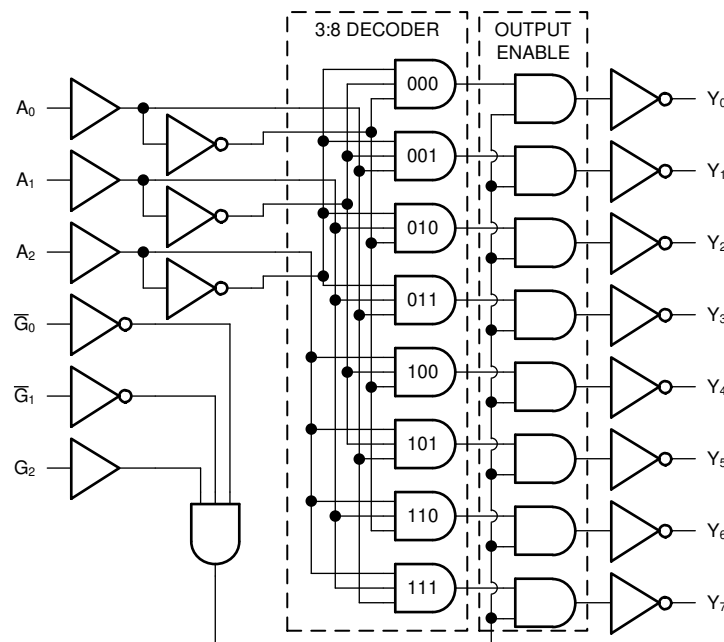

Figure 7-1. Functional Block Diagram '138

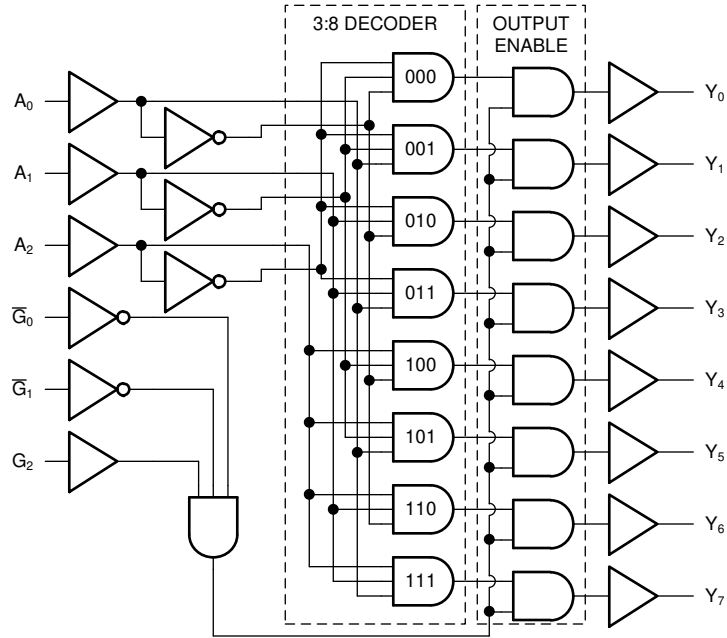

Figure 7-2. Functional Block Diagram '238

### 7.3 Device Functional Modes

**Table 7-1. Function Table 'HC138, 'HCT138**

INPUTS						OUTPUTS							
STROBE			ADDRESS										
G2	$\overline{G1}$	$\overline{G0}$	A <sub>2</sub>	A <sub>1</sub>	A <sub>0</sub>	Y <sub>0</sub>	Y <sub>1</sub>	Y <sub>2</sub>	Y <sub>3</sub>	Y <sub>4</sub>	Y <sub>5</sub>	Y <sub>6</sub>	Y <sub>7</sub>
X	X	H	X	X	X	H	H	H	H	H	H	H	H
L	X	X	X	X	X	H	H	H	H	H	H	H	H
X	H	X	X	X	X	H	H	H	H	H	H	H	H
H	L	L	L	L	L	L	H	H	H	H	H	H	H
H	L	L	L	L	H	H	L	H	H	H	H	H	H
H	L	L	L	H	L	H	H	L	H	H	H	H	H
H	L	L	L	H	H	H	H	H	L	H	H	H	H
H	L	L	H	L	L	H	H	H	H	L	H	H	H
H	L	L	H	L	H	H	H	H	H	H	L	H	H
H	L	L	H	H	L	H	H	H	H	H	H	L	H
H	L	L	H	H	H	H	H	H	H	H	H	H	L

H = High Voltage Level, L = Low Voltage Level, X = Don't Care

**Table 7-2. Function Table 'HC238, 'HCT238**

INPUTS						OUTPUTS							
STROBE			ADDRESS										
G2	$\overline{G1}$	$\overline{G0}$	A <sub>2</sub>	A <sub>1</sub>	A <sub>0</sub>	Y <sub>0</sub>	Y <sub>1</sub>	Y <sub>2</sub>	Y <sub>3</sub>	Y <sub>4</sub>	Y <sub>5</sub>	Y <sub>6</sub>	Y <sub>7</sub>
X	X	H	X	X	X	L	L	L	L	L	L	L	L
L	X	X	X	X	X	L	L	L	L	L	L	L	L
X	H	X	X	X	X	L	L	L	L	L	L	L	L
H	L	L	L	L	L	H	L	L	L	L	L	L	L
H	L	L	L	L	H	L	H	L	L	L	L	L	L
H	L	L	L	H	L	L	L	H	L	L	L	L	L
H	L	L	L	H	H	L	L	L	H	L	L	L	L
H	L	L	H	L	L	L	L	L	L	H	L	L	L
H	L	L	H	L	H	L	L	L	L	L	H	L	L
H	L	L	H	H	L	L	L	L	L	L	L	H	L
H	L	L	H	H	H	L	L	L	L	L	L	L	H

H = High Voltage Level, L = Low Voltage Level, X = Don't Care

## 8 Power Supply Recommendations

The power supply can be any voltage between the minimum and maximum supply voltage rating located in the *Recommended Operating Conditions*. Each  $V_{CC}$  terminal should have a good bypass capacitor to prevent power disturbance. A 0.1- $\mu\text{F}$  capacitor is recommended for this device. It is acceptable to parallel multiple bypass caps to reject different frequencies of noise. The 0.1- $\mu\text{F}$  and 1- $\mu\text{F}$  capacitors are commonly used in parallel. The bypass capacitor should be installed as close to the power terminal as possible for best results.

## 9 Layout

### 9.1 Layout Guidelines

When using multiple-input and multiple-channel logic devices inputs must not ever be left floating. In many cases, functions or parts of functions of digital logic devices are unused; for example, when only two inputs of a triple-input AND gate are used or only 3 of the 4 buffer gates are used. Such unused input pins must not be left unconnected because the undefined voltages at the outside connections result in undefined operational states. All unused inputs of digital logic devices must be connected to a logic high or logic low voltage, as defined by the input voltage specifications, to prevent them from floating. The logic level that must be applied to any particular unused input depends on the function of the device. Generally, the inputs are tied to GND or  $V_{CC}$ , whichever makes more sense for the logic function or is more convenient.

## 10 Device and Documentation Support

TI offers an extensive line of development tools. Tools and software to evaluate the performance of the device, generate code, and develop solutions are listed below.

### 10.1 Documentation Support

#### 10.1.1 Related Documentation

### 10.2 Receiving Notification of Documentation Updates

To receive notification of documentation updates, navigate to the device product folder on [ti.com](http://ti.com). Click on *Subscribe to updates* to register and receive a weekly digest of any product information that has changed. For change details, review the revision history included in any revised document.

### 10.3 Support Resources

TI E2E™ [support forums](#) are an engineer's go-to source for fast, verified answers and design help — straight from the experts. Search existing answers or ask your own question to get the quick design help you need.

Linked content is provided "AS IS" by the respective contributors. They do not constitute TI specifications and do not necessarily reflect TI's views; see TI's [Terms of Use](#).

### 10.4 Trademarks

TI E2E™ is a trademark of Texas Instruments.  
All trademarks are the property of their respective owners.

### 10.5 Electrostatic Discharge Caution



This integrated circuit can be damaged by ESD. Texas Instruments recommends that all integrated circuits be handled with appropriate precautions. Failure to observe proper handling and installation procedures can cause damage.

ESD damage can range from subtle performance degradation to complete device failure. Precision integrated circuits may be more susceptible to damage because very small parametric changes could cause the device not to meet its published specifications.

### 10.6 Glossary

[TI Glossary](#) This glossary lists and explains terms, acronyms, and definitions.

## 11 Mechanical, Packaging, and Orderable Information

The following pages include mechanical, packaging, and orderable information. This information is the most current data available for the designated devices. This data is subject to change without notice and revision of this document. For browser-based versions of this data sheet, refer to the left-hand navigation.

**PACKAGING INFORMATION**

Orderable Device	Status (1)	Package Type	Package Drawing	Pins	Package Qty	Eco Plan (2)	Lead finish/ Ball material (6)	MSL Peak Temp (3)	Op Temp (°C)	Device Marking (4/5)	Samples
5962-8688401EA	ACTIVE	CDIP	J	16	25	Non-RoHS & Green	SNPB	N / A for Pkg Type	-55 to 125	5962-8688401EA CD54HC238F3A	<a href="#">Samples</a>
CD54HC138F	ACTIVE	CDIP	J	16	25	Non-RoHS & Green	SNPB	N / A for Pkg Type	-55 to 125	CD54HC138F	<a href="#">Samples</a>
CD54HC138F3A	ACTIVE	CDIP	J	16	25	Non-RoHS & Green	SNPB	N / A for Pkg Type	-55 to 125	8406201EA CD54HC138F3A	<a href="#">Samples</a>
CD54HC238F3A	ACTIVE	CDIP	J	16	25	Non-RoHS & Green	SNPB	N / A for Pkg Type	-55 to 125	5962-8688401EA CD54HC238F3A	<a href="#">Samples</a>
CD54HCT138F	ACTIVE	CDIP	J	16	25	Non-RoHS & Green	SNPB	N / A for Pkg Type	-55 to 125	CD54HCT138F	<a href="#">Samples</a>
CD54HCT138F3A	ACTIVE	CDIP	J	16	25	Non-RoHS & Green	SNPB	N / A for Pkg Type	-55 to 125	8550401EA CD54HCT138F3A	<a href="#">Samples</a>
CD54HCT238F3A	ACTIVE	CDIP	J	16	25	Non-RoHS & Green	SNPB	N / A for Pkg Type	-55 to 125	5962-8974501EA CD54HCT238F3A	<a href="#">Samples</a>
CD74HC138E	ACTIVE	PDIP	N	16	25	RoHS & Green	NIPDAU	N / A for Pkg Type	-55 to 125	CD74HC138E	<a href="#">Samples</a>
CD74HC138M96	ACTIVE	SOIC	D	16	2500	RoHS & Green	NIPDAU   SN	Level-1-260C-UNLIM	-55 to 125	HC138M	<a href="#">Samples</a>
CD74HC138M96E4	ACTIVE				2500	TBD	Call TI	Call TI	-55 to 125		<a href="#">Samples</a>
CD74HC238E	ACTIVE	PDIP	N	16	25	RoHS & Green	NIPDAU	N / A for Pkg Type	-55 to 125	CD74HC238E	<a href="#">Samples</a>
CD74HC238EE4	ACTIVE	PDIP	N	16	25	RoHS & Green	NIPDAU	N / A for Pkg Type	-55 to 125	CD74HC238E	<a href="#">Samples</a>
CD74HC238M96	ACTIVE	SOIC	D	16	2500	RoHS & Green	NIPDAU   SN	Level-1-260C-UNLIM	-55 to 125	HC238M	<a href="#">Samples</a>
CD74HC238NSR	ACTIVE	SO	NS	16	2000	RoHS & Green	NIPDAU	Level-1-260C-UNLIM	-55 to 125	HC238M	<a href="#">Samples</a>
CD74HC238PWR	ACTIVE	TSSOP	PW	16	2000	RoHS & Green	NIPDAU   SN	Level-1-260C-UNLIM	-55 to 125	HJ238	<a href="#">Samples</a>
CD74HCT138E	ACTIVE	PDIP	N	16	25	RoHS & Green	NIPDAU	N / A for Pkg Type	-55 to 125	CD74HCT138E	<a href="#">Samples</a>
CD74HCT138M96	ACTIVE	SOIC	D	16	2500	RoHS & Green	NIPDAU   SN	Level-1-260C-UNLIM	-55 to 125	HCT138M	<a href="#">Samples</a>
CD74HCT238E	ACTIVE	PDIP	N	16	25	RoHS & Green	NIPDAU	N / A for Pkg Type	-55 to 125	CD74HCT238E	<a href="#">Samples</a>

Orderable Device	Status (1)	Package Type	Package Drawing	Pins	Package Qty	Eco Plan (2)	Lead finish/ Ball material (6)	MSL Peak Temp (3)	Op Temp (°C)	Device Marking (4/5)	Samples
CD74HCT238M96	ACTIVE	SOIC	D	16	2500	RoHS & Green	NIPDAU   SN	Level-1-260C-UNLIM	-55 to 125	HCT238M	<a href="#">Samples</a>
CD74HCT238PWR	ACTIVE	TSSOP	PW	16	2000	RoHS & Green	NIPDAU   SN	Level-1-260C-UNLIM	-55 to 125	HK238	<a href="#">Samples</a>

(1) The marketing status values are defined as follows:

**ACTIVE:** Product device recommended for new designs.

**LIFEBUY:** TI has announced that the device will be discontinued, and a lifetime-buy period is in effect.

**NRND:** Not recommended for new designs. Device is in production to support existing customers, but TI does not recommend using this part in a new design.

**PREVIEW:** Device has been announced but is not in production. Samples may or may not be available.

**OBsolete:** TI has discontinued the production of the device.

(2) **RoHS:** TI defines "RoHS" to mean semiconductor products that are compliant with the current EU RoHS requirements for all 10 RoHS substances, including the requirement that RoHS substance do not exceed 0.1% by weight in homogeneous materials. Where designed to be soldered at high temperatures, "RoHS" products are suitable for use in specified lead-free processes. TI may reference these types of products as "Pb-Free".

**RoHS Exempt:** TI defines "RoHS Exempt" to mean products that contain lead but are compliant with EU RoHS pursuant to a specific EU RoHS exemption.

**Green:** TI defines "Green" to mean the content of Chlorine (Cl) and Bromine (Br) based flame retardants meet JS709B low halogen requirements of <=1000ppm threshold. Antimony trioxide based flame retardants must also meet the <=1000ppm threshold requirement.

(3) MSL, Peak Temp. - The Moisture Sensitivity Level rating according to the JEDEC industry standard classifications, and peak solder temperature.

(4) There may be additional marking, which relates to the logo, the lot trace code information, or the environmental category on the device.

(5) Multiple Device Markings will be inside parentheses. Only one Device Marking contained in parentheses and separated by a "~" will appear on a device. If a line is indented then it is a continuation of the previous line and the two combined represent the entire Device Marking for that device.

(6) Lead finish/Ball material - Orderable Devices may have multiple material finish options. Finish options are separated by a vertical ruled line. Lead finish/Ball material values may wrap to two lines if the finish value exceeds the maximum column width.

**Important Information and Disclaimer:** The information provided on this page represents TI's knowledge and belief as of the date that it is provided. TI bases its knowledge and belief on information provided by third parties, and makes no representation or warranty as to the accuracy of such information. Efforts are underway to better integrate information from third parties. TI has taken and continues to take reasonable steps to provide representative and accurate information but may not have conducted destructive testing or chemical analysis on incoming materials and chemicals. TI and TI suppliers consider certain information to be proprietary, and thus CAS numbers and other limited information may not be available for release.

In no event shall TI's liability arising out of such information exceed the total purchase price of the TI part(s) at issue in this document sold by TI to Customer on an annual basis.

**OTHER QUALIFIED VERSIONS OF CD54HC138, CD54HC238, CD54HCT138, CD54HCT238, CD74HC138, CD74HC238, CD74HCT138, CD74HCT238 :**

- Catalog : [CD74HC138](#), [CD74HC238](#), [CD74HCT138](#), [CD74HCT238](#)
- Automotive : [CD74HC138-Q1](#), [CD74HC138-Q1](#)
- Military : [CD54HC138](#), [CD54HC238](#), [CD54HCT138](#), [CD54HCT238](#)

NOTE: Qualified Version Definitions:

- Catalog - TI's standard catalog product
- Automotive - Q100 devices qualified for high-reliability automotive applications targeting zero defects
- Military - QML certified for Military and Defense Applications

**TAPE AND REEL INFORMATION**

**QUADRANT ASSIGNMENTS FOR PIN 1 ORIENTATION IN TAPE**

\*All dimensions are nominal

Device	Package Type	Package Drawing	Pins	SPQ	Reel Diameter (mm)	Reel Width W1 (mm)	A0 (mm)	B0 (mm)	K0 (mm)	P1 (mm)	W (mm)	Pin1 Quadrant
CD74HC138M96	SOIC	D	16	2500	330.0	16.4	6.6	9.3	2.1	8.0	16.0	Q1
CD74HC138M96	SOIC	D	16	2500	330.0	16.4	6.5	10.3	2.1	8.0	16.0	Q1
CD74HC238M96	SOIC	D	16	2500	330.0	16.4	6.5	10.3	2.1	8.0	16.0	Q1
CD74HC238NSR	SO	NS	16	2000	330.0	16.4	8.2	10.5	2.5	12.0	16.0	Q1
CD74HC238PWR	TSSOP	PW	16	2000	330.0	12.4	6.9	5.6	1.6	8.0	12.0	Q1
CD74HC238PWR	TSSOP	PW	16	2000	330.0	12.4	6.9	5.6	1.6	8.0	12.0	Q1
CD74HCT138M96	SOIC	D	16	2500	330.0	16.4	6.5	10.3	2.1	8.0	16.0	Q1
CD74HCT138M96	SOIC	D	16	2500	330.0	16.4	6.6	9.3	2.1	8.0	16.0	Q1
CD74HCT238M96	SOIC	D	16	2500	330.0	16.4	6.5	10.3	2.1	8.0	16.0	Q1
CD74HCT238PWR	TSSOP	PW	16	2000	330.0	12.4	6.9	5.6	1.6	8.0	12.0	Q1
CD74HCT238PWR	TSSOP	PW	16	2000	330.0	12.4	6.9	5.6	1.6	8.0	12.0	Q1

**TAPE AND REEL BOX DIMENSIONS**

\*All dimensions are nominal

Device	Package Type	Package Drawing	Pins	SPQ	Length (mm)	Width (mm)	Height (mm)
CD74HC138M96	SOIC	D	16	2500	366.0	364.0	50.0
CD74HC138M96	SOIC	D	16	2500	356.0	356.0	35.0
CD74HC238M96	SOIC	D	16	2500	356.0	356.0	35.0
CD74HC238NSR	SO	NS	16	2000	356.0	356.0	35.0
CD74HC238PWR	TSSOP	PW	16	2000	356.0	356.0	35.0
CD74HC238PWR	TSSOP	PW	16	2000	356.0	356.0	35.0
CD74HCT138M96	SOIC	D	16	2500	356.0	356.0	35.0
CD74HCT138M96	SOIC	D	16	2500	366.0	364.0	50.0
CD74HCT238M96	SOIC	D	16	2500	356.0	356.0	35.0
CD74HCT238PWR	TSSOP	PW	16	2000	356.0	356.0	35.0
CD74HCT238PWR	TSSOP	PW	16	2000	356.0	356.0	35.0

**TUBE**

\*All dimensions are nominal

Device	Package Name	Package Type	Pins	SPQ	L (mm)	W (mm)	T (μm)	B (mm)
CD74HC138E	N	PDIP	16	25	506	13.97	11230	4.32
CD74HC138E	N	PDIP	16	25	506	13.97	11230	4.32
CD74HC238E	N	PDIP	16	25	506	13.97	11230	4.32
CD74HC238E	N	PDIP	16	25	506	13.97	11230	4.32
CD74HC238EE4	N	PDIP	16	25	506	13.97	11230	4.32
CD74HC238EE4	N	PDIP	16	25	506	13.97	11230	4.32
CD74HCT138E	N	PDIP	16	25	506	13.97	11230	4.32
CD74HCT138E	N	PDIP	16	25	506	13.97	11230	4.32
CD74HCT238E	N	PDIP	16	25	506	13.97	11230	4.32
CD74HCT238E	N	PDIP	16	25	506	13.97	11230	4.32



# PACKAGE OUTLINE

## NS0016A

### SOP - 2.00 mm max height

SOP

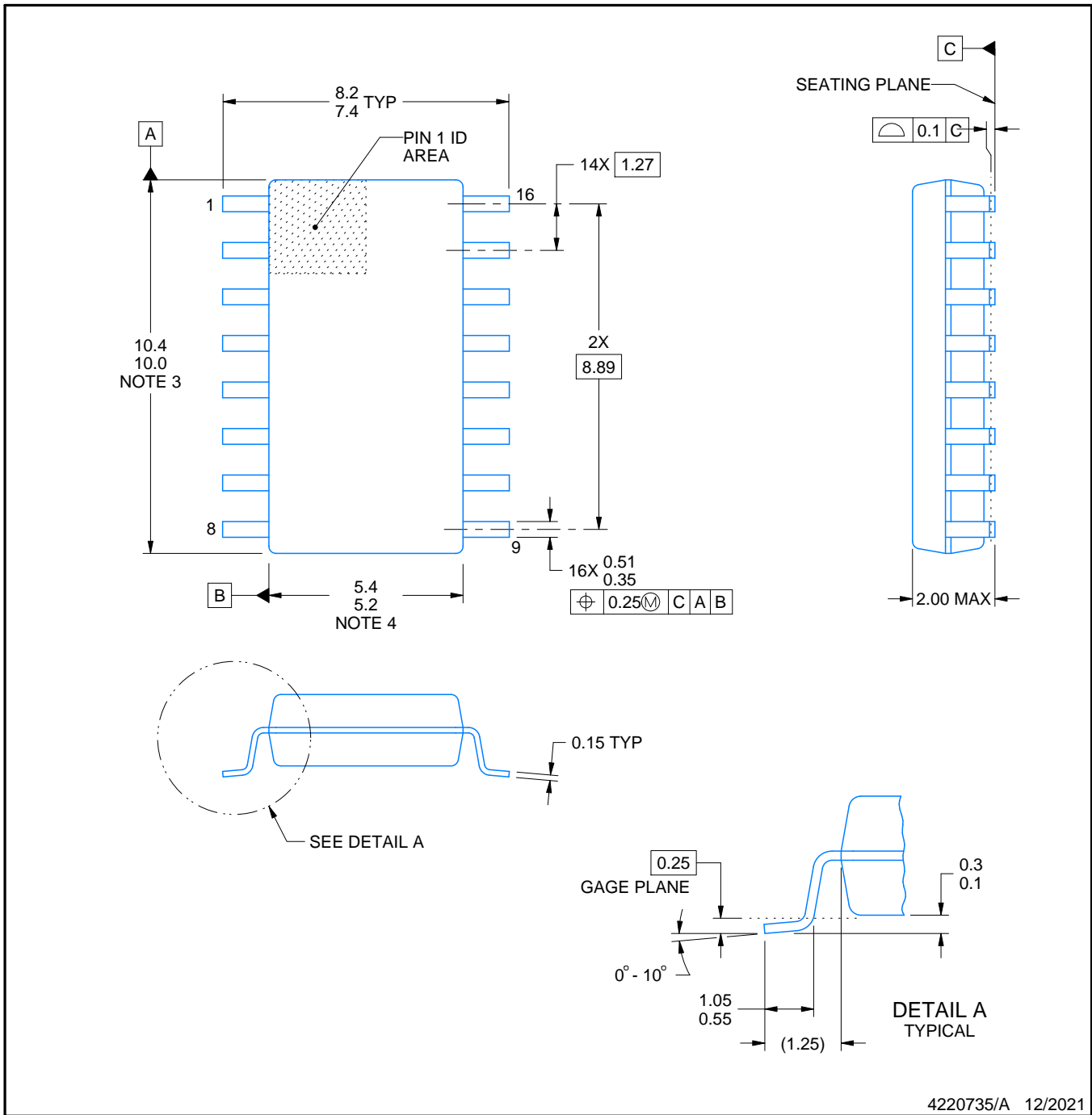

#### NOTES:

1. All linear dimensions are in millimeters. Dimensions in parenthesis are for reference only. Dimensioning and tolerancing per ASME Y14.5M.
2. This drawing is subject to change without notice.
3. This dimension does not include mold flash, protrusions, or gate burrs. Mold flash, protrusions, or gate burrs shall not exceed 0.15 mm, per side.
4. This dimension does not include interlead flash. Interlead flash shall not exceed 0.25 mm, per side.

# EXAMPLE BOARD LAYOUT

NS0016A

SOP - 2.00 mm max height

SOP



4220735/A 12/2021

NOTES: (continued)

5. Publication IPC-7351 may have alternate designs.

6. Solder mask tolerances between and around signal pads can vary based on board fabrication site.

# EXAMPLE STENCIL DESIGN

NS0016A

SOP - 2.00 mm max height

SOP



SOLDER PASTE EXAMPLE  
BASED ON 0.125 mm THICK STENCIL  
SCALE:7X

4220735/A 12/2021

NOTES: (continued)

7. Laser cutting apertures with trapezoidal walls and rounded corners may offer better paste release. IPC-7525 may have alternate design recommendations.
8. Board assembly site may have different recommendations for stencil design.

D (R-PDSO-G16)

PLASTIC SMALL OUTLINE



- NOTES:
- A. All linear dimensions are in inches (millimeters).
  - B. This drawing is subject to change without notice.
  - C. Body length does not include mold flash, protrusions, or gate burrs. Mold flash, protrusions, or gate burrs shall not exceed 0.006 (0,15) each side.
  - D. Body width does not include interlead flash. Interlead flash shall not exceed 0.017 (0,43) each side.
  - E. Reference JEDEC MS-012 variation AC.



4220204/A 02/2017

NOTES:

1. All linear dimensions are in millimeters. Any dimensions in parenthesis are for reference only. Dimensioning and tolerancing per ASME Y14.5M.
2. This drawing is subject to change without notice.
3. This dimension does not include mold flash, protrusions, or gate burrs. Mold flash, protrusions, or gate burrs shall not exceed 0.15 mm per side.
4. This dimension does not include interlead flash. Interlead flash shall not exceed 0.25 mm per side.
5. Reference JEDEC registration MO-153.

# EXAMPLE BOARD LAYOUT

PW0016A

TSSOP - 1.2 mm max height

SMALL OUTLINE PACKAGE



LAND PATTERN EXAMPLE  
EXPOSED METAL SHOWN  
SCALE: 10X



SOLDER MASK DETAILS

4220204/A 02/2017

NOTES: (continued)

- 6. Publication IPC-7351 may have alternate designs.
- 7. Solder mask tolerances between and around signal pads can vary based on board fabrication site.

# EXAMPLE STENCIL DESIGN

PW0016A

TSSOP - 1.2 mm max height

SMALL OUTLINE PACKAGE



SOLDER PASTE EXAMPLE  
BASED ON 0.125 mm THICK STENCIL  
SCALE: 10X

4220204/A 02/2017

NOTES: (continued)

8. Laser cutting apertures with trapezoidal walls and rounded corners may offer better paste release. IPC-7525 may have alternate design recommendations.
9. Board assembly site may have different recommendations for stencil design.

# MECHANICAL DATA

NS (R-PDSO-G\*\*)

PLASTIC SMALL-OUTLINE PACKAGE

14-PINS SHOWN



- NOTES:
- A. All linear dimensions are in millimeters.
  - B. This drawing is subject to change without notice.
  - C. Body dimensions do not include mold flash or protrusion, not to exceed 0,15.

J (R-GDIP-T\*\*)

14 LEADS SHOWN

CERAMIC DUAL IN-LINE PACKAGE



DIM \ PINS **	14	16	18	20
A	0.300 (7,62) BSC	0.300 (7,62) BSC	0.300 (7,62) BSC	0.300 (7,62) BSC
B MAX	0.785 (19,94)	.840 (21,34)	0.960 (24,38)	1.060 (26,92)
B MIN	—	—	—	—
C MAX	0.300 (7,62)	0.300 (7,62)	0.310 (7,87)	0.300 (7,62)
C MIN	0.245 (6,22)	0.245 (6,22)	0.220 (5,59)	0.245 (6,22)



4040083/F 03/03

- NOTES:
- All linear dimensions are in inches (millimeters).
  - This drawing is subject to change without notice.
  - This package is hermetically sealed with a ceramic lid using glass frit.
  - Index point is provided on cap for terminal identification only on press ceramic glass frit seal only.
  - Falls within MIL STD 1835 GDIP1-T14, GDIP1-T16, GDIP1-T18 and GDIP1-T20.

N (R-PDIP-T\*\*)

PLASTIC DUAL-IN-LINE PACKAGE

16 PINS SHOWN



- NOTES:
- A. All linear dimensions are in inches (millimeters).
  - B. This drawing is subject to change without notice.
  - Falls within JEDEC MS-001, except 18 and 20 pin minimum body length (Dim A).
  - The 20 pin end lead shoulder width is a vendor option, either half or full width.

## IMPORTANT NOTICE AND DISCLAIMER

TI PROVIDES TECHNICAL AND RELIABILITY DATA (INCLUDING DATA SHEETS), DESIGN RESOURCES (INCLUDING REFERENCE DESIGNS), APPLICATION OR OTHER DESIGN ADVICE, WEB TOOLS, SAFETY INFORMATION, AND OTHER RESOURCES "AS IS" AND WITH ALL FAULTS, AND DISCLAIMS ALL WARRANTIES, EXPRESS AND IMPLIED, INCLUDING WITHOUT LIMITATION ANY IMPLIED WARRANTIES OF MERCHANTABILITY, FITNESS FOR A PARTICULAR PURPOSE OR NON-INFRINGEMENT OF THIRD PARTY INTELLECTUAL PROPERTY RIGHTS.

These resources are intended for skilled developers designing with TI products. You are solely responsible for (1) selecting the appropriate TI products for your application, (2) designing, validating and testing your application, and (3) ensuring your application meets applicable standards, and any other safety, security, regulatory or other requirements.

These resources are subject to change without notice. TI grants you permission to use these resources only for development of an application that uses the TI products described in the resource. Other reproduction and display of these resources is prohibited. No license is granted to any other TI intellectual property right or to any third party intellectual property right. TI disclaims responsibility for, and you will fully indemnify TI and its representatives against, any claims, damages, costs, losses, and liabilities arising out of your use of these resources.

TI's products are provided subject to [TI's Terms of Sale](#) or other applicable terms available either on [ti.com](https://www.ti.com) or provided in conjunction with such TI products. TI's provision of these resources does not expand or otherwise alter TI's applicable warranties or warranty disclaimers for TI products.

TI objects to and rejects any additional or different terms you may have proposed.

Mailing Address: Texas Instruments, Post Office Box 655303, Dallas, Texas 75265  
Copyright © 2024, Texas Instruments Incorporated

## Looking for pricing, stock, or lifecycle information?

Click below to explore more details on WIN SOURCE:

 [View CD54HC238F3A](#) on WIN SOURCE

 [Texas Instruments](#) Information

## Optimize Your Supply Chain with WIN SOURCE Solutions

-  Global Sourcing Solution
-  Obsolete Management
-  Cost Control Management
-  Shortage Management
-  Alternative Solution
-  Excess Inventory Management