



**THE DATASHEET OF  
AM26LS33AMJ**



## AM26LS32Ax, AM26LS33Ax Quadruple Differential Line Receivers

### 1 Features

- AM26LS32A Devices meet or exceed the requirements of ANSI TIA/EIA-422-B, TIA/EIA-423-B, and ITU recommendations V.10 and V.11
- AM26LS32A Devices have  $\pm 7$ -V Common-mode range with  $\pm 200$ -mV sensitivity
- AM26LS33A Devices have  $\pm 15$ -V common-mode range with  $\pm 500$ -mV sensitivity
- Input hysteresis 50 mV typical
- Operate from a single 5-V supply
- Low-power Schottky circuitry
- 3-State outputs
- Complementary output-enable inputs
- Input impedance 12 k $\Omega$  minimum
- Open input fail-safe

### 2 Applications

- High-reliability automotive applications
- [Factory automation](#)
- [ATM](#) and cash counters
- Smart grids
- AC and [servo motor](#) drives

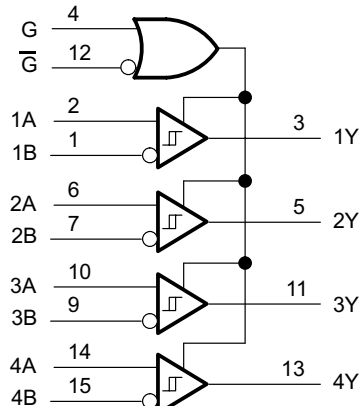

Copyright © 2016, Texas Instruments Incorporated

Pin numbers are for D, N, NS, or PW packages only.

### Logic Diagram (Positive Logic)

### 3 Description

The AM26LS32Ax and AM26LS33Ax devices are quadruple differential line receivers for balanced and unbalanced digital data transmission. The enable function is common to all four receivers and offers a choice of active-high or active-low input. The 3-state outputs permit connection directly to a bus-organized system. When the inputs are open, the fail-safe design makes sure the outputs always are high.

Compared to the AM26LS32 and the AM26LS33, the AM26LS32A and AM26LS33A incorporate an additional stage of amplification to improve sensitivity. The input impedance has been increased, resulting in less loading of the bus line. The additional stage has increased propagation delay; however, this does not affect interchangeability in most applications.

The AM26LS32AC and AM26LS33AC are characterized for operation from 0°C to 70°C. The AM26LS32AI is characterized for operation from –40°C to 85°C. The AM26LS32AM and AM26LS33AM are characterized for operation over the full military temperature range of –55°C to 125°C.

### Package Information

PART NUMBER	PACKAGE <sup>(1)</sup>	PACKAGE SIZE <sup>(2)</sup>
AM26LS3xAC	PDIP (16)	19.3 mm × 9.4 mm
AM26LS32AI	SOIC (16)	9.9 mm × 6 mm
AM26LS32AC	SO (16)	10.2 mm × 7.8 mm
	TSSOP (16)	5. mm × 6.4 mm
AM26LS3xAM	CDIP (16)	19.56 mm × 6.92 mm
	LCCC (20)	8.9 mm × 8.9 mm

(1) For all available packages, see the orderable addendum at the end of the data sheet.

(2) The package size (length × width) is a nominal value and includes pins, where applicable.



## Table of Contents

<b>1 Features</b> .....	1	8.2 Functional Block Diagram.....	12
<b>2 Applications</b> .....	1	8.3 Feature Description.....	12
<b>3 Description</b> .....	1	8.4 Device Functional Modes.....	12
<b>4 Revision History</b> .....	2	<b>9 Application and Implementation</b> .....	13
<b>5 Pin Configuration and Functions</b> .....	3	9.1 Application Information.....	13
<b>6 Specifications</b> .....	4	9.2 Typical Application.....	13
6.1 Absolute Maximum Ratings.....	4	9.3 Power Supply Recommendations.....	14
6.2 ESD Ratings.....	4	9.4 Layout.....	14
6.3 Recommended Operating Conditions.....	4	<b>10 Device and Documentation Support</b> .....	16
6.4 Thermal Information.....	5	10.1 Receiving Notification of Documentation Updates..	16
6.5 Electrical Characteristics.....	6	10.2 Support Resources.....	16
6.6 Switching Characteristics.....	7	10.3 Trademarks.....	16
6.7 Dissipation Ratings.....	7	10.4 Electrostatic Discharge Caution.....	16
6.8 Typical Characteristics.....	8	10.5 Glossary.....	16
<b>7 Parameter Measurement Information</b> .....	10	<b>11 Mechanical, Packaging, and Orderable Information</b> .....	16
<b>8 Detailed Description</b> .....	12		
8.1 Overview.....	12		

## 4 Revision History

NOTE: Page numbers for previous revisions may differ from page numbers in the current version.

Changes from Revision F (August 2016) to Revision G (August 2023)	Page
• Changed the Device Information table to the <i>Package Information</i> table.....	1
• Changed the <i>Thermal Information</i> table.....	5
• Changed the <i>Typical Characteristics</i> .....	8

Changes from Revision E (October 2007) to Revision F (August 2016)	Page
• Added <i>Applications</i> section, <i>ESD Ratings</i> table, <i>Feature Description</i> section, <i>Device Functional Modes</i> , <i>Application and Implementation</i> section, <i>Power Supply Recommendations</i> section, <i>Layout</i> section, <i>Device and Documentation Support</i> section, and <i>Mechanical, Packaging, and Orderable Information</i> section.....	1
• Changed R <sub>θJA</sub> values in the <i>Thermal Information</i> table: 73 to 75.7 for (D), 67 to 45.3 (N), 64 to 75.8 (NS), and 108 to 102.7 (PW).....	5

## 5 Pin Configuration and Functions

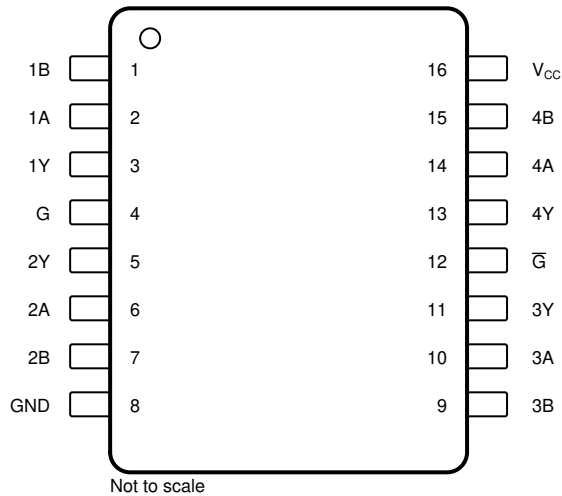

**Figure 5-1. D, J, N, NS, and PW Package 16-Pin SOIC, CDIP, PDIP, SO, and TSSOP (Top View)**

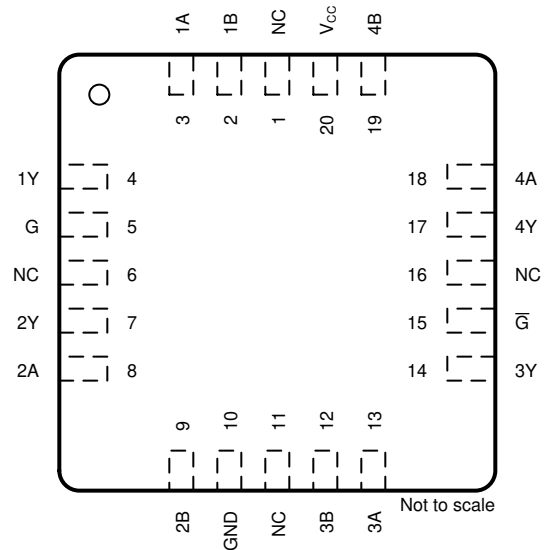

NC - No internal connection

**Figure 5-2. FK Package, 20-Pin LCCC (Top View)**

NAME	PIN		TYPE	DESCRIPTION
	SOIC, CDIP, PDIP, SO, TSSOP	LCCC		
1A	2	3	I	RS422/RS485 differential input (noninverting)
1B	1	2	I	RS422/RS485 differential input (inverting)
1Y	3	4	O	Logic level output
2A	6	8	I	RS422/RS485 differential input (noninverting)
2B	7	9	I	RS422/RS485 differential input (inverting)
2Y	5	7	O	Logic level output
3A	10	13	I	RS422/RS485 differential input (noninverting)
3B	9	12	I	RS422/RS485 differential input (inverting)
3Y	11	14	O	Logic level output
4A	14	18	I	RS422/RS485 differential input (noninverting)
4B	15	19	I	RS422/RS485 differential input (inverting)
4Y	13	17	O	Logic level output
Ḡ	12	15	I	Active-Low select
G	4	5	I	Active-High select
GND	8	10	—	Ground
NC	—	1, 6, 11, 16	—	No internal connection
V <sub>CC</sub>	16	20	—	Power supply

## 6 Specifications

### 6.1 Absolute Maximum Ratings

over operating free-air temperature range (unless otherwise noted)<sup>(1)</sup>

		MIN	MAX	UNIT
Supply voltage, $V_{CC}$ <sup>(2)</sup>			7	V
Input voltage, $V_I$	Any differential input		±25	V
	Other inputs		7	
Differential input voltage, $V_{ID}$ <sup>(3)</sup>			±25	V
Continuous total power dissipation		See <a href="#">Section 6.7</a>		
Case temperature, $T_C$ , FK package (60 s)			260	°C
Lead temperature <sup>(4)</sup>	D or N package (10 s)		260	°C
	J package (60 s)		300	
Storage temperature, $T_{stg}$		-65	150	°C

- (1) Stresses beyond those listed under *Absolute Maximum Ratings* may cause permanent damage to the device. These are stress ratings only, which do not imply functional operation of the device at these or any other conditions beyond those indicated under *Recommended Operating Conditions*. Exposure to absolute-maximum-rated conditions for extended periods may affect device reliability.
- (2) All voltage values, except differential voltages, are with respect to the network ground terminal.
- (3) Differential voltage values are at the noninverting (A) input terminals with respect to the inverting (B) input terminals.
- (4) 1.6 mm (1/16 inch) from case

### 6.2 ESD Ratings

		VALUE	UNIT
$V_{(ESD)}$ Electrostatic discharge	Human-body model (HBM), per ANSI/ESDA/JEDEC JS-001 <sup>(1)</sup>	±500	V
	Charged-device model (CDM), per JEDEC specification JESD22-C101 <sup>(2)</sup>	±2000	

- (1) JEDEC document JEP155 states that 500-V HBM allows safe manufacturing with a standard ESD control process.
- (2) JEDEC document JEP157 states that 250-V CDM allows safe manufacturing with a standard ESD control process.

### 6.3 Recommended Operating Conditions

		MIN	NOM	MAX	UNIT
$V_{CC}$ Supply voltage	AM26LS32AC, AM26LS32AI, AM26LS33AC	4.75	5	5.25	V
	AM26LS32AM, AM26LS33AM	4.5	5	5.5	
$V_{IH}$ High-level input voltage		2			V
$V_{IL}$ Low-level input voltage				0.8	V
$V_{IC}$ Common-mode input voltage	AM26LS32A			±7	V
	AM26LS33A			±15	
$I_{OH}$ High-level output current				-440	μA
$I_{OL}$ Low-level output current				8	mA
$T_A$ Operating free-air temperature	AM26LS32AC, AM26LS33AC	0		70	°C
	AM26LS32AI	-40		85	
	AM26LS32AM, AM26LS33AM	-55		125	

## 6.4 Thermal Information

THERMAL METRIC <sup>(1)</sup>	AM26LS3xAC, AM26LS32AI				AM26LS32AC				UNIT	
	D (SOIC)	DR (SOIC-Reel)	N (PDIP)	NR (PDIP-Reel)	NS (SO)	NSR (SO-Reel)	PW (TSSOP)	PWR (TSSOP-Reel)		
	16 PINS	16 PINS	16 PINS	16 PINS	16 PINS	16 PINS	16 PINS	16 PINS		
$R_{\theta JA}$	Junction-to-ambient thermal resistance	75.7	84.6	45.3	60.6	75.8	88.5	102.7	107.5	°C/W
$R_{\theta JC(top)}$	Junction-to-case (top) thermal resistance	35	43.5	32.7	48.1	32.9	46.2	37.8	38.4	°C/W
$R_{\theta JB}$	Junction-to-board thermal resistance	33.3	43.2	25.3	40.6	36.6	50.7	47.7	53.7	°C/W
$\Psi_{JT}$	Junction-to-top characterization parameter	6.6	10.4	17.8	27.5	6	13.5	3	3.2	°C/W
$\Psi_{JB}$	Junction-to-board characterization parameter	33	42.8	25.1	40.3	36.3	50.3	47.1	53.1	°C/W

- (1) For more information about traditional and new thermal metrics, see the [Semiconductor and IC Package Thermal Metrics](#) application report.

## 6.5 Electrical Characteristics

over recommended ranges of  $V_{CC}$ ,  $V_{IC}$ , and operating free-air temperature (unless otherwise noted)

PARAMETER		TEST CONDITIONS		MIN	TYP <sup>(1)</sup>	MAX	UNIT	
$V_{IT+}$	Positive-going input threshold voltage	$V_O = V_{OHmin}$ , $I_{OH} = -440 \mu A$	AM26LS32A			0.2	V	
			AM26LS33A			0.5		
$V_{IT-}$	Negative-going input threshold voltage	$V_O = 0.45 V$ , $I_{OL} = 8 mA$	AM26LS32A			-0.2 <sup>(2)</sup>	V	
			AM26LS33A			-0.5 <sup>(2)</sup>		
$V_{hys}$	Hysteresis voltage ( $V_{IT+} - V_{IT-}$ )				50		mV	
$V_{IK}$	Enable-input clamp voltage	$V_{CC} = MIN$ , $I_I = -18 mA$				-1.5	V	
$V_{OH}$	High-level output voltage	$V_{CC} = MIN$ , $V_{ID} = 1 V$ , $V_{I(G)} = 0.8 V$ , $I_{OH} = -440 \mu A$	AM26LS32AC, AM26LS33AC			2.7	V	
			AM26LS32AM, AM26LS32AI, AM26LS33AM			2.5		
$V_{OL}$	Low-level output voltage	$V_{CC} = MIN$ , $V_{ID} = -1 V$ , $V_{I(G)} = 0.8 V$	$I_{OL} = 4 mA$			0.4	V	
			$I_{OL} = 8 mA$			0.45		
$I_{OZ}$	Off-state (high-impedance state) output current	$V_{CC} = MAX$	$V_O = 2.4 V$			20	$\mu A$	
			$V_O = 0.4 V$			-20		
$I_I$	Line input current	$V_I = 15 V$ , other input at $-10 V$ to $15 V$				1.2	mA	
		$V_I = -15 V$ , other input at $-15 V$ to $10 V$				-1.7		
$I_{I(EN)}$	Enable input current	$V_I = 5.5 V$				100	$\mu A$	
$I_H$	High-level enable current	$V_I = 2.7 V$				20	$\mu A$	
$I_L$	Low-level enable current	$V_I = 0.4 V$				-0.36	mA	
$r_i$	Input resistance	$V_{IC} = -15 V$ to $15 V$ , one input to ac ground			12	15	k $\Omega$	
$I_{OS}$	Short-circuit output current <sup>(3)</sup>	$V_{CC} = MAX$				-15	-85	mA
$I_{CC}$	Supply current	$V_{CC} = MAX$ , all outputs disabled				52	70	mA

(1) All typical values are at  $V_{CC} = 5 V$ ,  $T_A = 25^\circ C$ , and  $V_{IC} = 0$ .

(2) The algebraic convention, in which the less positive (more negative) limit is designated as minimum, is used in this data sheet for threshold levels only.

(3) Not more than one output must be shorted to ground at a time, and duration of the short circuit must not exceed one second.

## 6.6 Switching Characteristics

$C_L = 15 \text{ pF}$ ,  $V_{CC} = 5 \text{ V}$ , and  $T_A = 25^\circ\text{C}$  (see [Section 7](#); unless otherwise noted)

PARAMETER		MIN	TYP <sup>(1)</sup>	MAX	UNIT
$t_{PLH}$	Propagation delay time, low-to-high-level output		20	35	ns
$t_{PHL}$	Propagation delay time, high-to-low-level output		22	35	ns
$t_{PZH}$	Output enable time to high level		17	22	ns
$t_{PZL}$	Output enable time to low level		20	25	ns
$t_{PHZ}$	Output disable time from high level		21	30	ns
$t_{PLZ}$	Output disable time from low level		30	40	ns

(1) All typical values are at  $V_{CC} = 5 \text{ V}$ ,  $T_A = 25^\circ\text{C}$ , and  $V_{IC} = 0$ .

## 6.7 Dissipation Ratings

PACKAGE	$T_A \leq 25^\circ\text{C}$ POWER RATING	DERATION FACTOR ABOVE $T_A = 25^\circ\text{C}$	$T_A = 70^\circ\text{C}$ POWER RATING	$T_A = 125^\circ\text{C}$ POWER RATING
FK	1375 mW	11 mW/°C	880 mW	275 mW
J	1375 mW	11 mW/°C	880 mW	275 mW

## 6.8 Typical Characteristics

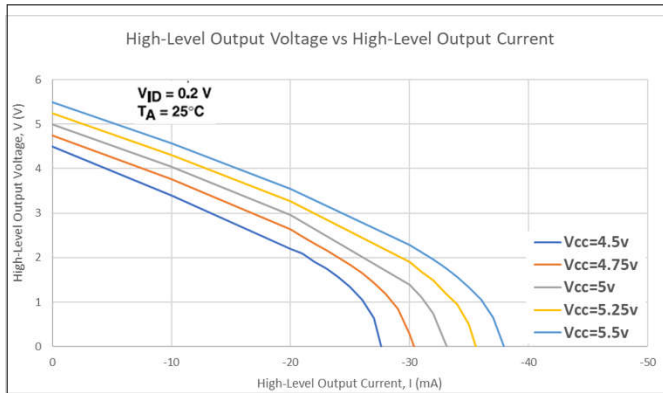

**Figure 6-1. High-Level Output Voltage vs High-Level Output Current**

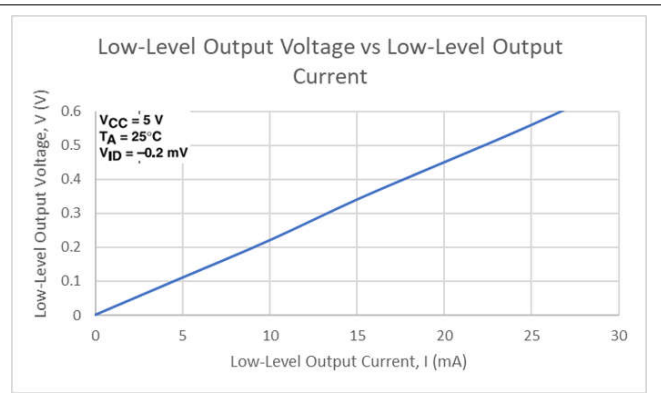

**Figure 6-2. Low-Level Output Voltage vs Low-Level Output Current**

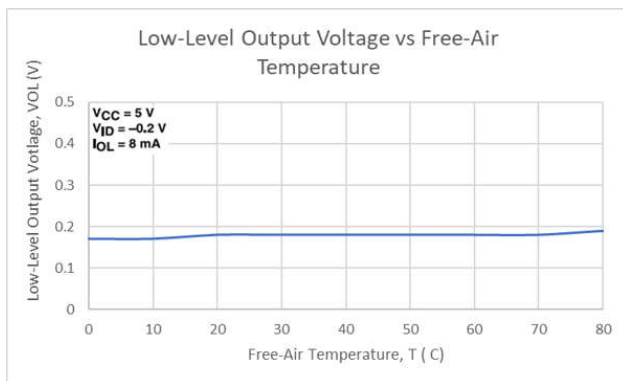

**Figure 6-3. Low-Level Output Voltage vs Free-Air Temperature**

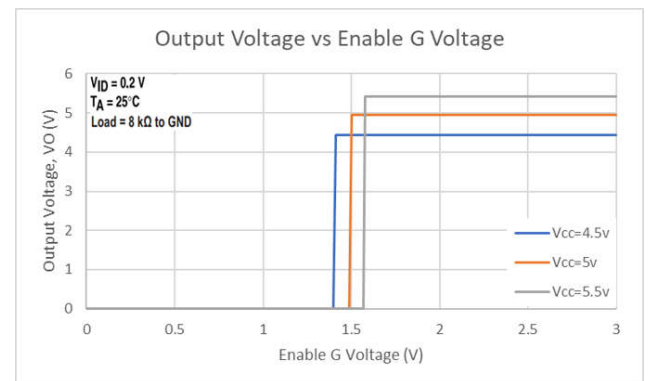

**Figure 6-4. Output Voltage vs Enable G Voltage**

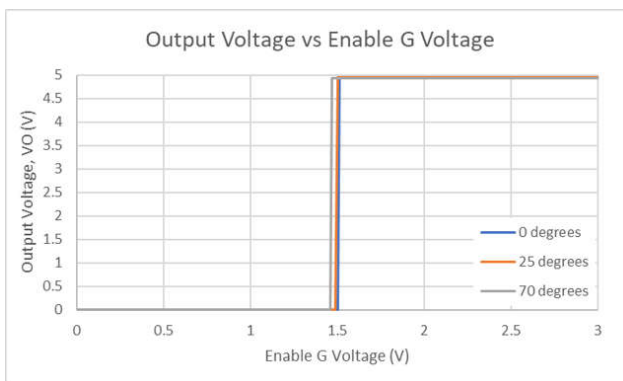

**Figure 6-5. Output Voltage vs Enable G Voltage**

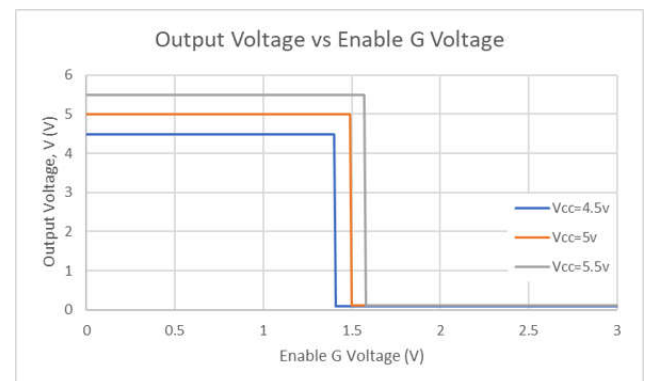

**Figure 6-6. Output Voltage vs Enable G Voltage**

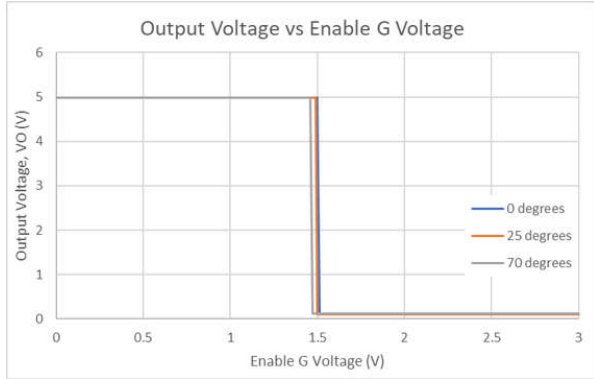

**Figure 6-7. Output Voltage vs Enable G Voltage**

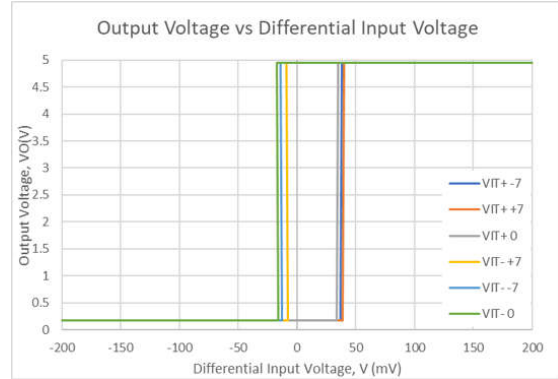

**Figure 6-8. AM26LS32A Output Voltage vs Differential Input Voltage**

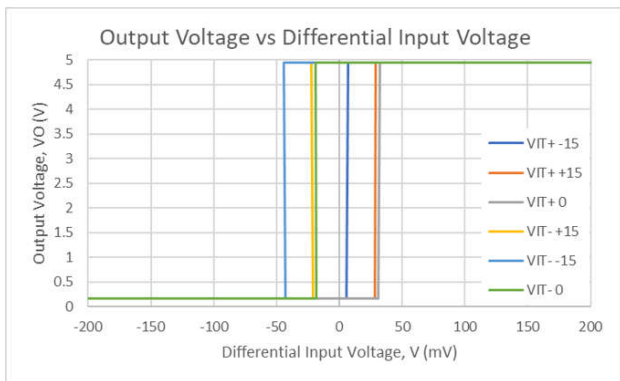

**Figure 6-9. AM26LS33A Output Voltage vs Differential Input Voltage**

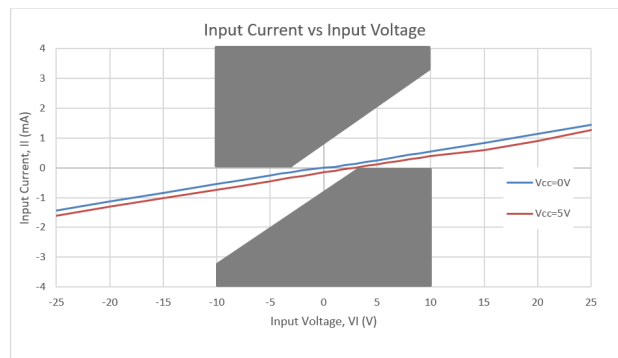

The unshaded area shows requirements of paragraph 4.2.1 of ANSI Standards EIA/TIA-422-B and EIA/TIA-423-B.

**Figure 6-10. Input Current vs Input Voltage**

## 7 Parameter Measurement Information

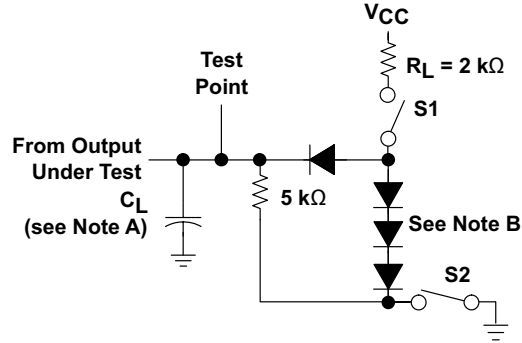

Figure 7-1. Test Circuit

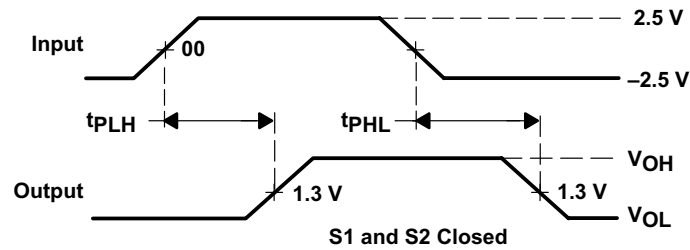

Figure 7-2. Voltage Waveforms For  $t_{PLH}$ ,  $t_{PHL}$

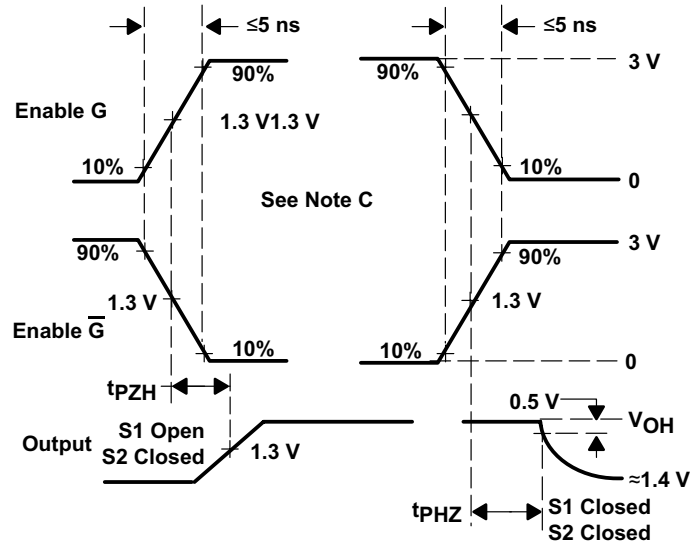
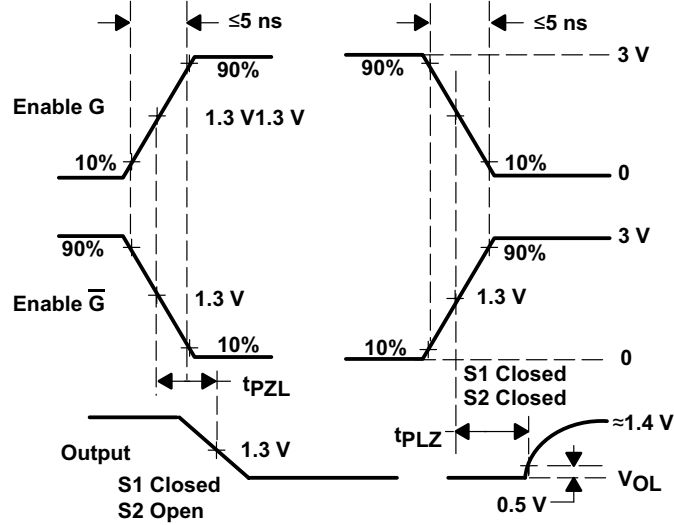
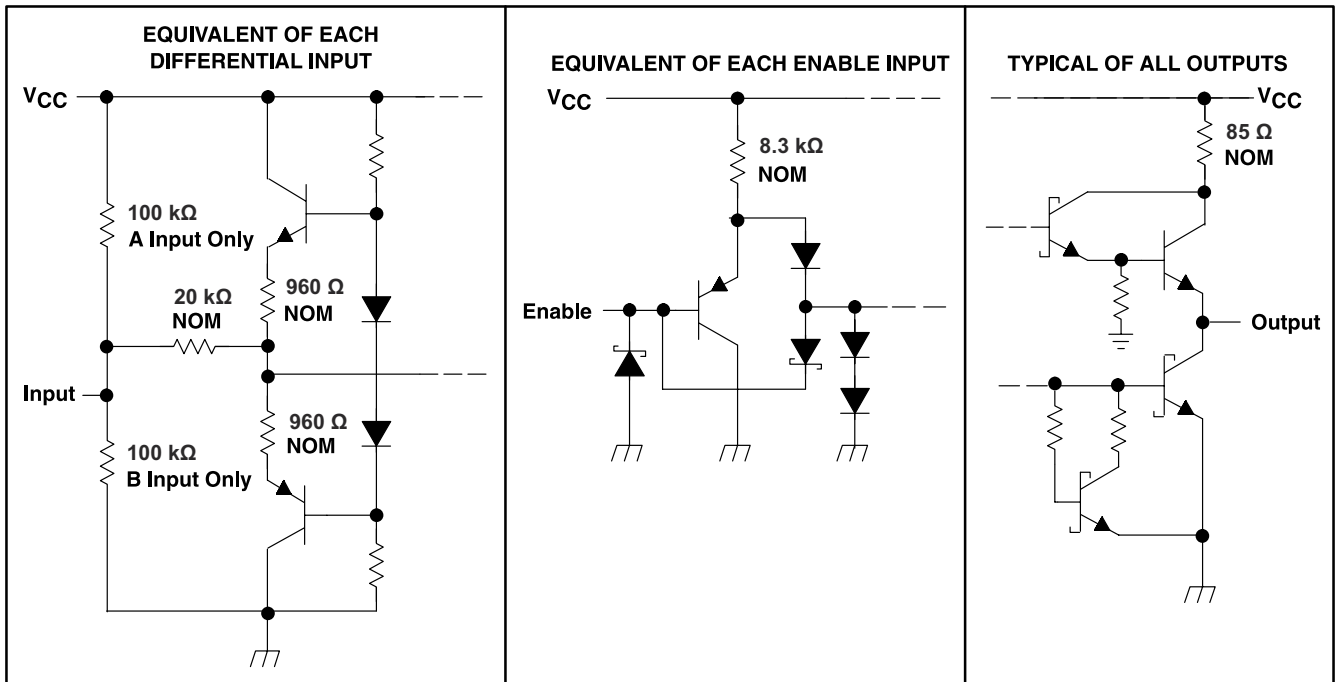

Figure 7-3. Voltage Waveforms For  $t_{PHZ}$ ,  $t_{PZH}$



- A. CL includes probe and jig capacitance.
- B. All diodes are 1N3064 or equivalent.
- C. Enable G is tested with  $\bar{G}$  high,  $\bar{G}$  is tested with G low.

**Figure 7-4. Voltage Waveforms For  $t_{PLZ}$ ,  $t_{PZL}$**



Copyright © 2016, Texas Instruments Incorporated

**Figure 7-5. Schematics of Inputs and Outputs**

## 8 Detailed Description

### 8.1 Overview

The AM26LS32 is a quadruple-differential line receiver that meets the necessary requirements for NSI TIA/EIA-422-B, TIA/EIA-423-B, and ITU Recommendation V.10 and V.11. This device allows a low-power or low-voltage MCU to interface with heavy machinery, subsystems, and other devices through long wires of up to 1000 m, giving any design a reliable and easy-to-use connection. As any RS422 interface, the AM26LS32 works in a differential voltage range, which enables very good signal integrity.

### 8.2 Functional Block Diagram

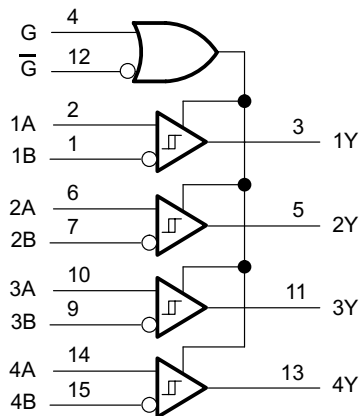

Copyright © 2016, Texas Instruments Incorporated

**Figure 8-1. Logic Diagram (Positive Logic)**

### 8.3 Feature Description

The device can be configured using the G and  $\bar{G}$  logic inputs to select receiver output. The high voltage or logic 1 on the G pin allows the device to operate on an active-high, and having a low voltage or logic 0 on the G enables active low operation. These are simple ways to configure the logic to match that of the receiving or transmitting controller or microprocessor.

### 8.4 Device Functional Modes

The receivers implemented in these RS422 devices can be configured using the G and  $\bar{G}$  logic pins to be enabled or disabled. This allows users to ignore or filter out transmissions as desired.

**Table 8-1. Function Table, Each Receiver**

DIFFERENTIAL A–B	ENABLES <sup>(1)</sup>		OUTPUT <sup>(1)</sup> Y
	G	$\bar{G}$	
$V_{ID} \geq V_{IT+}$	H	X	H
	X	L	H
$V_{IT-} \leq V_{ID} \leq V_{IT+}$	H	X	?
	X	L	?
$V_{ID} \leq V_{IT-}$	H	X	L
	X	L	L
X	L	H	Z
Open	H	X	H
	X	L	H

(1) H = High level, L = Low level, X = Irrelevant, Z = High impedance (off), ? = Indeterminate

## 9 Application and Implementation

### Note

Information in the following applications sections is not part of the TI component specification, and TI does not warrant its accuracy or completeness. TI's customers are responsible for determining suitability of components for their purposes, as well as validating and testing their design implementation to confirm system functionality.

### 9.1 Application Information

When using AM26LS32A as a receiver, the AM26LS31AC can allow multiple AM26LS32As to be used causing an increase in the amount of outputs.

### 9.2 Typical Application

Figure 9-1 shows a configuration with no termination. Although reflections are present at the receiver inputs at a data signaling rate of 200 kbps with no termination, the RS-422-compliant receiver reads only the input differential voltage and produces a clean signal at the output.

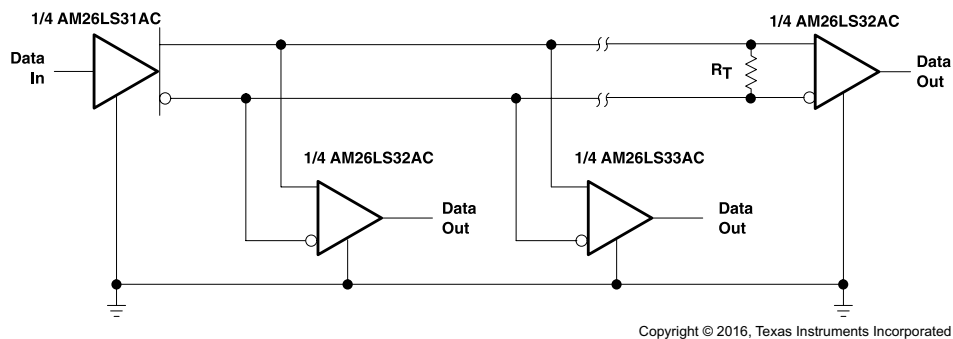

<sup>†</sup> $R_T$  equals the characteristic impedance of the line.

**Figure 9-1. Application Diagram**

#### 9.2.1 Design Requirements

Resistor and capacitor (if used) termination values are shown for each laboratory experiment, but vary from system to system. For example, the termination resistor,  $R_T$ , must be within 20% of the characteristic impedance,  $Z_O$ , of the cable and can vary from about 80  $\Omega$  to 120  $\Omega$ .

#### 9.2.2 Detailed Design Procedure

Add a  $V_{CC}$  bypass capacitor (0.1  $\mu\text{F}$  or more). Either enable (G pin) input can turn on the receivers, so connect the desired enable to a compatible logic line output. The other enable input must be tied to the inactive state supply rail. If the receivers must always be active, then connect both enables to the supply rail such that at least one is set to an active-state rail.  $V_{CC}$  must be 5 V within 10% and logic inputs must provide TTL-compatible voltage levels A & B Inputs can lead to an external connector or can be left unconnected. The last receiver on a cable requires termination, either on-board or use as an external resistor. Unused Y outputs can be left unconnected.

## 9.2.3 Application Curve

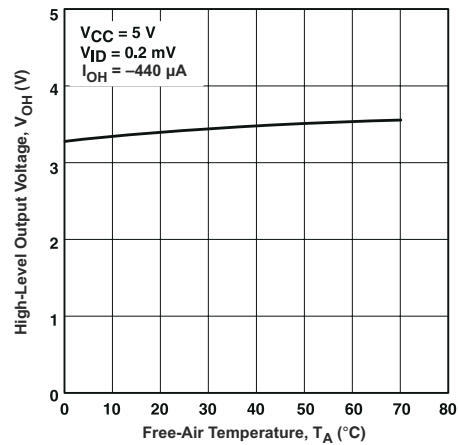

Figure 9-2. High-Level Output Voltage vs Free-Air Temperature

## 9.3 Power Supply Recommendations

Place 0.1- $\mu\text{F}$  bypass capacitors close to the power-supply pins to reduce errors coupling in from noisy or high-impedance power supplies.

## 9.4 Layout

### 9.4.1 Layout Guidelines

For best operational performance of the device, use good PCB layout practices including:

- Noise can propagate into analog circuitry through the power pins of the circuit as a whole, as well as the operational amplifier. Bypass capacitors are used to reduce the coupled noise by providing low impedance power sources local to the analog circuitry.
- Connect low-ESR, 0.1- $\mu\text{F}$  ceramic bypass capacitors between each supply pin and ground, placed as close to the device as possible. A single bypass capacitor from  $V+$  to ground is applicable for single supply applications.
- Separate grounding for analog and digital portions of circuitry is one of the simplest and most-effective methods of noise suppression. One or more layers on multilayer PCBs are usually devoted to ground planes. A ground plane helps distribute heat and reduces EMI noise pickup. Make sure to physically separate digital and analog grounds, paying attention to the flow of the ground current.
- To reduce parasitic coupling, run the input traces as far away from the supply or output traces as possible. If it is not possible to keep them separate, it is much better to cross the sensitive trace perpendicular as opposed to in parallel with the noisy trace.
- Place the external components as close to the device as possible. Keeping RF and RG close to the inverting input minimizes parasitic capacitance.
- Keep the length of input traces as short as possible. Always remember that the input traces are the most sensitive part of the circuit.
- Consider a driven, low-impedance guard ring around the critical traces. A guard ring can significantly reduce leakage currents from nearby traces that are at different potentials.

### 9.4.2 Layout Example

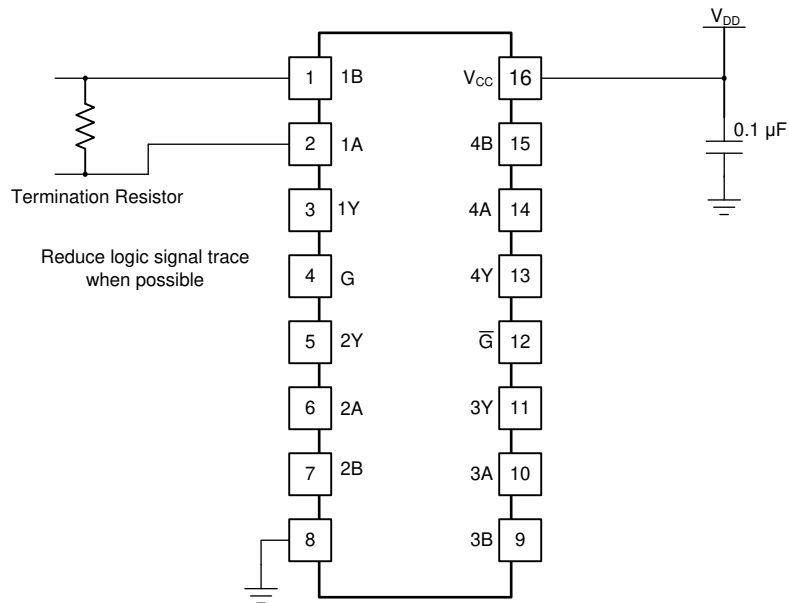

**Figure 9-3. Layout with PCB Recommendations**

## 10 Device and Documentation Support

### 10.1 Receiving Notification of Documentation Updates

To receive notification of documentation updates, navigate to the device product folder on [ti.com](http://ti.com). Click on *Subscribe to updates* to register and receive a weekly digest of any product information that has changed. For change details, review the revision history included in any revised document.

### 10.2 Support Resources

TI E2E™ [support forums](#) are an engineer's go-to source for fast, verified answers and design help — straight from the experts. Search existing answers or ask your own question to get the quick design help you need.

Linked content is provided "AS IS" by the respective contributors. They do not constitute TI specifications and do not necessarily reflect TI's views; see TI's [Terms of Use](#).

### 10.3 Trademarks

TI E2E™ is a trademark of Texas Instruments.  
All trademarks are the property of their respective owners.

### 10.4 Electrostatic Discharge Caution



This integrated circuit can be damaged by ESD. Texas Instruments recommends that all integrated circuits be handled with appropriate precautions. Failure to observe proper handling and installation procedures can cause damage.

ESD damage can range from subtle performance degradation to complete device failure. Precision integrated circuits may be more susceptible to damage because very small parametric changes could cause the device not to meet its published specifications.

### 10.5 Glossary

[TI Glossary](#) This glossary lists and explains terms, acronyms, and definitions.

## 11 Mechanical, Packaging, and Orderable Information

The following pages include mechanical, packaging, and orderable information. This information is the most current data available for the designated devices. This data is subject to change without notice and revision of this document. For browser-based versions of this data sheet, refer to the left-hand navigation.

**PACKAGING INFORMATION**

Orderable Device	Status (1)	Package Type	Package Drawing	Pins	Package Qty	Eco Plan (2)	Lead finish/ Ball material (6)	MSL Peak Temp (3)	Op Temp (°C)	Device Marking (4/5)	Samples
5962-7802003M2A	ACTIVE	LCCC	FK	20	55	Non-RoHS & Green	SNPB	N / A for Pkg Type	-55 to 125	5962- 7802003M2A AM26LS 32AMFKB	<a href="#">Samples</a>
5962-7802003MEA	ACTIVE	CDIP	J	16	25	Non-RoHS & Green	SNPB	N / A for Pkg Type	-55 to 125	5962-7802003ME A AM26LS32AMJB	<a href="#">Samples</a>
5962-7802003MFA	ACTIVE	CFP	W	16	25	Non-RoHS & Green	SNPB	N / A for Pkg Type	-55 to 125	5962-7802003MF A AM26LS32AMWB	<a href="#">Samples</a>
5962-7802004M2A	ACTIVE	LCCC	FK	20	55	Non-RoHS & Green	SNPB	N / A for Pkg Type	-55 to 125	5962- 7802004M2A AM26LS 33AMFKB	<a href="#">Samples</a>
5962-7802004MEA	ACTIVE	CDIP	J	16	25	Non-RoHS & Green	SNPB	N / A for Pkg Type	-55 to 125	5962-7802004ME A AM26LS33AMJB	<a href="#">Samples</a>
5962-7802004MFA	ACTIVE	CFP	W	16	25	Non-RoHS & Green	SNPB	N / A for Pkg Type	-55 to 125	5962-7802004MF A AM26LS33AMWB	<a href="#">Samples</a>
AM26LS32ACDR	ACTIVE	SOIC	D	16	2500	RoHS & Green	NIPDAU	Level-1-260C-UNLIM	0 to 70	26LS32AC	<a href="#">Samples</a>
AM26LS32ACDRE4	ACTIVE	SOIC	D	16	2500	RoHS & Green	NIPDAU	Level-1-260C-UNLIM	0 to 70	26LS32AC	<a href="#">Samples</a>
AM26LS32ACDRG4	ACTIVE	SOIC	D	16	2500	RoHS & Green	NIPDAU	Level-1-260C-UNLIM	0 to 70	26LS32AC	<a href="#">Samples</a>
AM26LS32ACN	ACTIVE	PDIP	N	16	25	RoHS & Green	NIPDAU	N / A for Pkg Type	0 to 70	AM26LS32ACN	<a href="#">Samples</a>
AM26LS32ACNSR	ACTIVE	SO	NS	16	2000	RoHS & Green	NIPDAU	Level-1-260C-UNLIM	0 to 70	26LS32A	<a href="#">Samples</a>
AM26LS32ACNSRG4	ACTIVE	SO	NS	16	2000	RoHS & Green	NIPDAU	Level-1-260C-UNLIM	0 to 70	26LS32A	<a href="#">Samples</a>
AM26LS32ACPWR	ACTIVE	TSSOP	PW	16	2000	RoHS & Green	NIPDAU	Level-1-260C-UNLIM	0 to 70	SA32A	<a href="#">Samples</a>
AM26LS32ACPWRE4	ACTIVE	TSSOP	PW	16	2000	RoHS & Green	NIPDAU	Level-1-260C-UNLIM	0 to 70	SA32A	<a href="#">Samples</a>
AM26LS32AIDR	ACTIVE	SOIC	D	16	2500	RoHS & Green	NIPDAU	Level-1-260C-UNLIM	-40 to 85	26LS32AI	<a href="#">Samples</a>

Orderable Device	Status (1)	Package Type	Package Drawing	Pins	Package Qty	Eco Plan (2)	Lead finish/ Ball material (6)	MSL Peak Temp (3)	Op Temp (°C)	Device Marking (4/5)	Samples
AM26LS32AIDRG4	ACTIVE	SOIC	D	16	2500	RoHS & Green	NIPDAU	Level-1-260C-UNLIM	-40 to 85	26LS32AI	<a href="#">Samples</a>
AM26LS32AIN	ACTIVE	PDIP	N	16	25	RoHS & Green	NIPDAU	N / A for Pkg Type	-40 to 85	AM26LS32AIN	<a href="#">Samples</a>
AM26LS32AMFKB	ACTIVE	LCCC	FK	20	55	Non-RoHS & Green	SNPB	N / A for Pkg Type	-55 to 125	5962-7802003M2A AM26LS32AMFKB	<a href="#">Samples</a>
AM26LS32AMJ	ACTIVE	CDIP	J	16	25	Non-RoHS & Green	SNPB	N / A for Pkg Type	-55 to 125	AM26LS32AMJ	<a href="#">Samples</a>
AM26LS32AMJB	ACTIVE	CDIP	J	16	25	Non-RoHS & Green	SNPB	N / A for Pkg Type	-55 to 125	5962-7802003MEA AM26LS32AMJB	<a href="#">Samples</a>
AM26LS32AMWB	ACTIVE	CFP	W	16	25	Non-RoHS & Green	SNPB	N / A for Pkg Type	-55 to 125	5962-7802003MFA AM26LS32AMWB	<a href="#">Samples</a>
AM26LS33ACDR	ACTIVE	SOIC	D	16	2500	RoHS & Green	NIPDAU	Level-1-260C-UNLIM	0 to 70	26LS33AC	<a href="#">Samples</a>
AM26LS33ACN	ACTIVE	PDIP	N	16	25	RoHS & Green	NIPDAU	N / A for Pkg Type	0 to 70	AM26LS33ACN	<a href="#">Samples</a>
AM26LS33AMFKB	ACTIVE	LCCC	FK	20	55	Non-RoHS & Green	SNPB	N / A for Pkg Type	-55 to 125	5962-7802004M2A AM26LS33AMFKB	<a href="#">Samples</a>
AM26LS33AMJ	ACTIVE	CDIP	J	16	25	Non-RoHS & Green	SNPB	N / A for Pkg Type	-55 to 125	AM26LS33AMJ	<a href="#">Samples</a>
AM26LS33AMJB	ACTIVE	CDIP	J	16	25	Non-RoHS & Green	SNPB	N / A for Pkg Type	-55 to 125	5962-7802004MEA AM26LS33AMJB	<a href="#">Samples</a>
AM26LS33AMWB	ACTIVE	CFP	W	16	25	Non-RoHS & Green	SNPB	N / A for Pkg Type	-55 to 125	5962-7802004MFA AM26LS33AMWB	<a href="#">Samples</a>

(1) The marketing status values are defined as follows:

**ACTIVE:** Product device recommended for new designs.

**LIFEBUY:** TI has announced that the device will be discontinued, and a lifetime-buy period is in effect.

**NRND:** Not recommended for new designs. Device is in production to support existing customers, but TI does not recommend using this part in a new design.

**PREVIEW:** Device has been announced but is not in production. Samples may or may not be available.

**OBSELETE:** TI has discontinued the production of the device.

<sup>(2)</sup> **RoHS:** TI defines "RoHS" to mean semiconductor products that are compliant with the current EU RoHS requirements for all 10 RoHS substances, including the requirement that RoHS substance do not exceed 0.1% by weight in homogeneous materials. Where designed to be soldered at high temperatures, "RoHS" products are suitable for use in specified lead-free processes. TI may reference these types of products as "Pb-Free".

**RoHS Exempt:** TI defines "RoHS Exempt" to mean products that contain lead but are compliant with EU RoHS pursuant to a specific EU RoHS exemption.

**Green:** TI defines "Green" to mean the content of Chlorine (Cl) and Bromine (Br) based flame retardants meet JS709B low halogen requirements of <=1000ppm threshold. Antimony trioxide based flame retardants must also meet the <=1000ppm threshold requirement.

<sup>(3)</sup> MSL, Peak Temp. - The Moisture Sensitivity Level rating according to the JEDEC industry standard classifications, and peak solder temperature.

<sup>(4)</sup> There may be additional marking, which relates to the logo, the lot trace code information, or the environmental category on the device.

<sup>(5)</sup> Multiple Device Markings will be inside parentheses. Only one Device Marking contained in parentheses and separated by a "~" will appear on a device. If a line is indented then it is a continuation of the previous line and the two combined represent the entire Device Marking for that device.

<sup>(6)</sup> Lead finish/Ball material - Orderable Devices may have multiple material finish options. Finish options are separated by a vertical ruled line. Lead finish/Ball material values may wrap to two lines if the finish value exceeds the maximum column width.

**Important Information and Disclaimer:**The information provided on this page represents TI's knowledge and belief as of the date that it is provided. TI bases its knowledge and belief on information provided by third parties, and makes no representation or warranty as to the accuracy of such information. Efforts are underway to better integrate information from third parties. TI has taken and continues to take reasonable steps to provide representative and accurate information but may not have conducted destructive testing or chemical analysis on incoming materials and chemicals. TI and TI suppliers consider certain information to be proprietary, and thus CAS numbers and other limited information may not be available for release.

In no event shall TI's liability arising out of such information exceed the total purchase price of the TI part(s) at issue in this document sold by TI to Customer on an annual basis.

**OTHER QUALIFIED VERSIONS OF AM26LS32A, AM26LS32AM, AM26LS33A, AM26LS33AM :**

● Catalog : [AM26LS32A](#), [AM26LS33A](#)

● Military : [AM26LS32AM](#), [AM26LS33AM](#)

● Space : [AM26LS33A-SP](#), [AM26LS33A-SP](#)

NOTE: Qualified Version Definitions:

● Catalog - TI's standard catalog product

● Military - QML certified for Military and Defense Applications

- Space - Radiation tolerant, ceramic packaging and qualified for use in Space-based application

**TAPE AND REEL INFORMATION**

**QUADRANT ASSIGNMENTS FOR PIN 1 ORIENTATION IN TAPE**



\*All dimensions are nominal

Device	Package Type	Package Drawing	Pins	SPQ	Reel Diameter (mm)	Reel Width W1 (mm)	A0 (mm)	B0 (mm)	K0 (mm)	P1 (mm)	W (mm)	Pin1 Quadrant
AM26LS32ACDR	SOIC	D	16	2500	330.0	16.4	6.5	10.3	2.1	8.0	16.0	Q1
AM26LS32ACDR	SOIC	D	16	2500	330.0	16.4	6.5	10.3	2.1	8.0	16.0	Q1
AM26LS32ACDR	SOIC	D	16	2500	330.0	16.4	6.5	10.3	2.1	8.0	16.0	Q1
AM26LS32ACNSR	SO	NS	16	2000	330.0	16.4	8.2	10.5	2.5	12.0	16.0	Q1
AM26LS32ACNSR	SO	NS	16	2000	330.0	16.4	8.2	10.5	2.5	12.0	16.0	Q1
AM26LS32ACPWR	TSSOP	PW	16	2000	330.0	12.4	6.9	5.6	1.6	8.0	12.0	Q1
AM26LS32ACPWR	TSSOP	PW	16	2000	330.0	12.4	6.9	5.6	1.6	8.0	12.0	Q1
AM26LS32AIDR	SOIC	D	16	2500	330.0	16.4	6.5	10.3	2.1	8.0	16.0	Q1
AM26LS33ACDR	SOIC	D	16	2500	330.0	16.4	6.5	10.3	2.1	8.0	16.0	Q1

**TAPE AND REEL BOX DIMENSIONS**

\*All dimensions are nominal

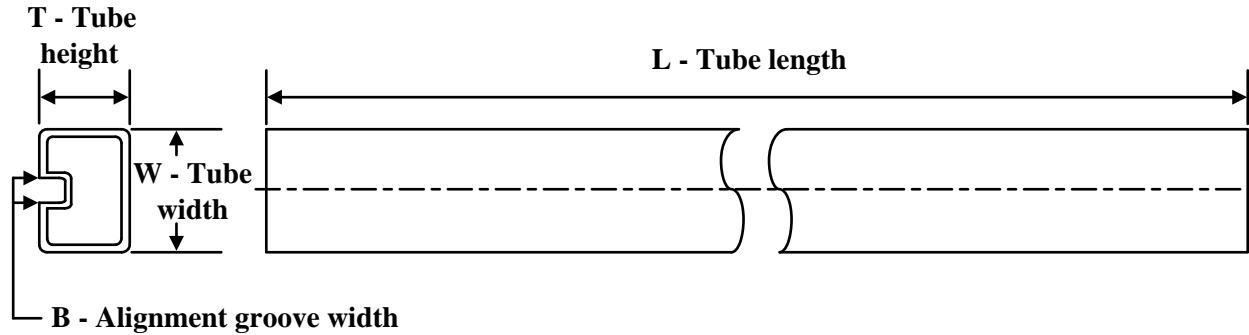
Device	Package Type	Package Drawing	Pins	SPQ	Length (mm)	Width (mm)	Height (mm)
AM26LS32ACDR	SOIC	D	16	2500	340.5	336.1	32.0
AM26LS32ACDR	SOIC	D	16	2500	353.0	353.0	32.0
AM26LS32ACDR	SOIC	D	16	2500	356.0	356.0	35.0
AM26LS32ACNSR	SO	NS	16	2000	353.0	353.0	32.0
AM26LS32ACNSR	SO	NS	16	2000	367.0	367.0	38.0
AM26LS32ACPWR	TSSOP	PW	16	2000	353.0	353.0	32.0
AM26LS32ACPWR	TSSOP	PW	16	2000	367.0	367.0	35.0
AM26LS32AIDR	SOIC	D	16	2500	353.0	353.0	32.0
AM26LS33ACDR	SOIC	D	16	2500	353.0	353.0	32.0

**TUBE**

\*All dimensions are nominal

Device	Package Name	Package Type	Pins	SPQ	L (mm)	W (mm)	T (μm)	B (mm)
5962-7802003M2A	FK	LCCC	20	55	506.98	12.06	2030	NA
5962-7802003MFA	W	CFP	16	25	506.98	26.16	6220	NA
5962-7802004M2A	FK	LCCC	20	55	506.98	12.06	2030	NA
5962-7802004MFA	W	CFP	16	25	506.98	26.16	6220	NA
AM26LS32ACD	D	SOIC	16	40	507	8	3940	4.32
AM26LS32ACD	D	SOIC	16	40	506.6	8	3940	4.32
AM26LS32ACDE4	D	SOIC	16	40	507	8	3940	4.32
AM26LS32ACDE4	D	SOIC	16	40	506.6	8	3940	4.32
AM26LS32ACDG4	D	SOIC	16	40	507	8	3940	4.32
AM26LS32ACDG4	D	SOIC	16	40	506.6	8	3940	4.32
AM26LS32ACN	N	PDIP	16	25	506	13.97	11230	4.32
AM26LS32ACPW	PW	TSSOP	16	90	530	10.2	3600	3.5
AM26LS32AID	D	SOIC	16	40	507	8	3940	4.32
AM26LS32AIDE4	D	SOIC	16	40	507	8	3940	4.32
AM26LS32AIDG4	D	SOIC	16	40	507	8	3940	4.32
AM26LS32AIN	N	PDIP	16	25	506	13.97	11230	4.32
AM26LS32AMFKB	FK	LCCC	20	55	506.98	12.06	2030	NA
AM26LS32AMWB	W	CFP	16	25	506.98	26.16	6220	NA
AM26LS33ACD	D	SOIC	16	40	507	8	3940	4.32
AM26LS33ACDG4	D	SOIC	16	40	507	8	3940	4.32
AM26LS33ACN	N	PDIP	16	25	506	13.97	11230	4.32
AM26LS33AMFKB	FK	LCCC	20	55	506.98	12.06	2030	NA
AM26LS33AMWB	W	CFP	16	25	506.98	26.16	6220	NA



# PACKAGE OUTLINE

## NS0016A

### SOP - 2.00 mm max height

SOP

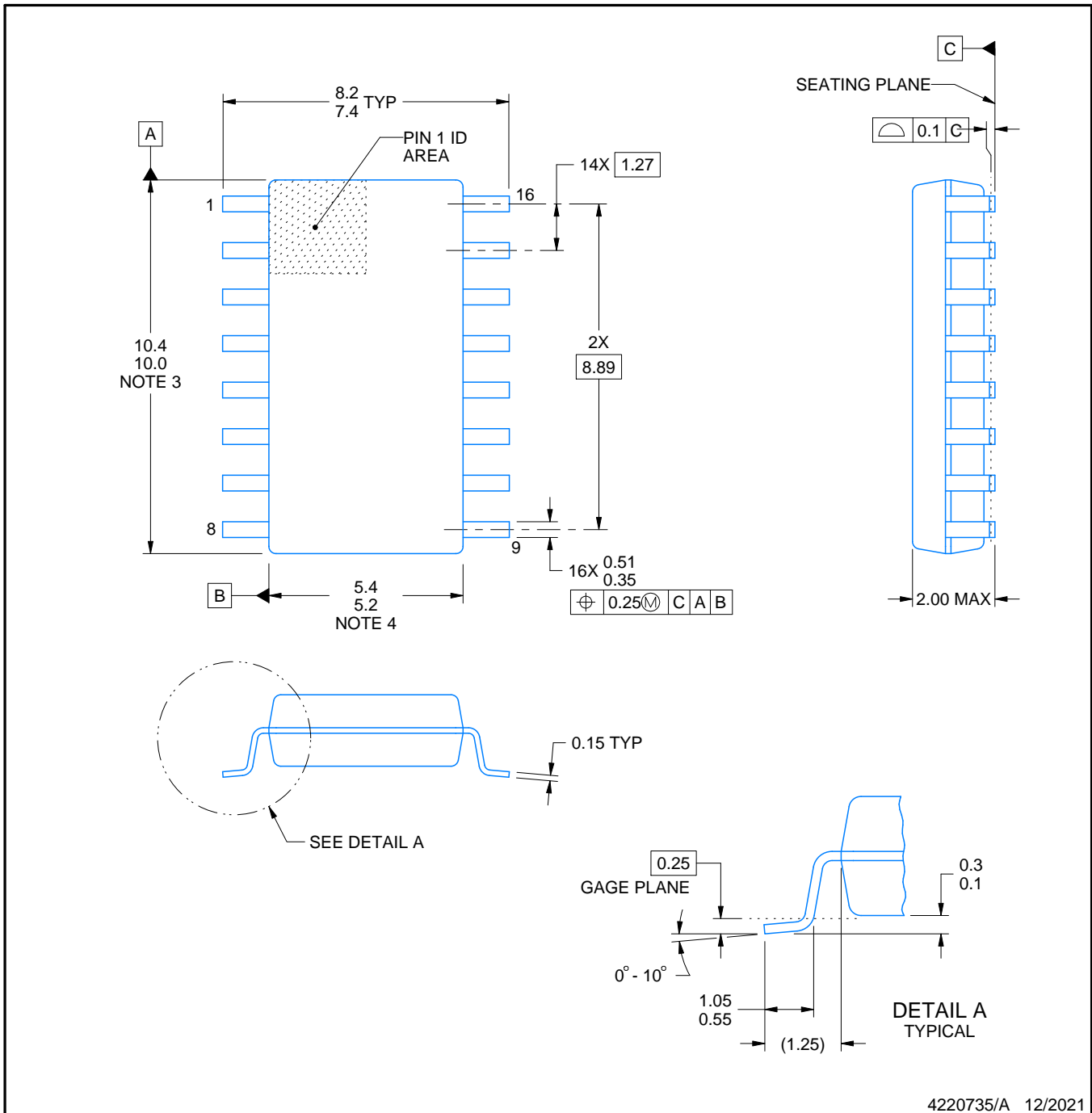

#### NOTES:

1. All linear dimensions are in millimeters. Dimensions in parenthesis are for reference only. Dimensioning and tolerancing per ASME Y14.5M.
2. This drawing is subject to change without notice.
3. This dimension does not include mold flash, protrusions, or gate burrs. Mold flash, protrusions, or gate burrs shall not exceed 0.15 mm, per side.
4. This dimension does not include interlead flash. Interlead flash shall not exceed 0.25 mm, per side.

# EXAMPLE BOARD LAYOUT

NS0016A

SOP - 2.00 mm max height

SOP

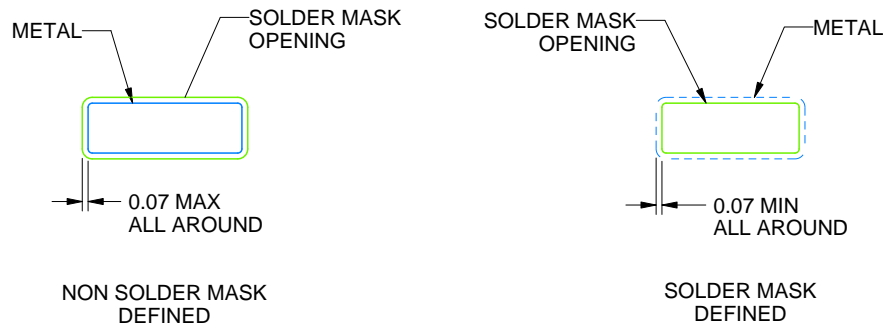

SOLDER MASK DETAILS

4220735/A 12/2021

NOTES: (continued)

- 5. Publication IPC-7351 may have alternate designs.
- 6. Solder mask tolerances between and around signal pads can vary based on board fabrication site.

# EXAMPLE STENCIL DESIGN

NS0016A

SOP - 2.00 mm max height

SOP

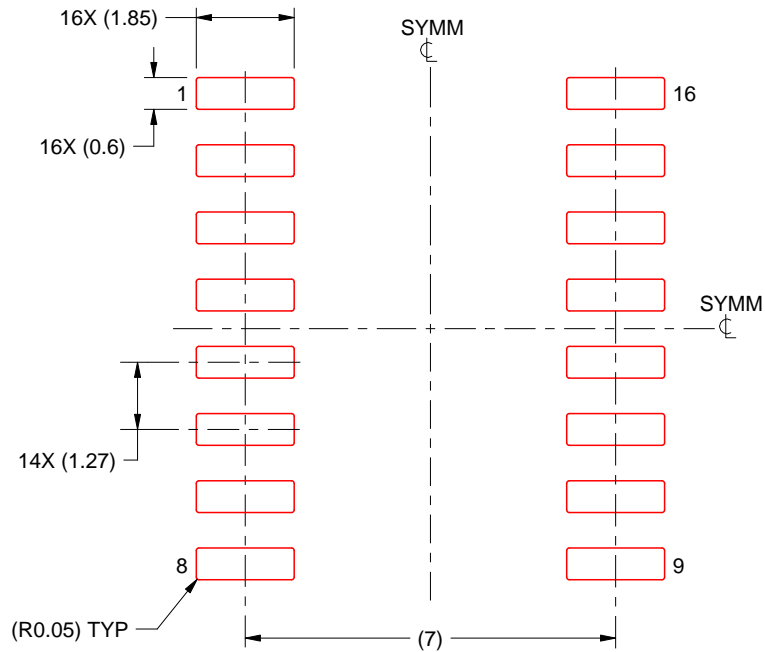

SOLDER PASTE EXAMPLE  
BASED ON 0.125 mm THICK STENCIL  
SCALE:7X

4220735/A 12/2021

NOTES: (continued)

7. Laser cutting apertures with trapezoidal walls and rounded corners may offer better paste release. IPC-7525 may have alternate design recommendations.
8. Board assembly site may have different recommendations for stencil design.

D (R-PDSO-G16)

PLASTIC SMALL OUTLINE



- NOTES:
- A. All linear dimensions are in inches (millimeters).
  - B. This drawing is subject to change without notice.
  - C. Body length does not include mold flash, protrusions, or gate burrs. Mold flash, protrusions, or gate burrs shall not exceed 0.006 (0,15) each side.
  - D. Body width does not include interlead flash. Interlead flash shall not exceed 0.017 (0,43) each side.
  - E. Reference JEDEC MS-012 variation AC.

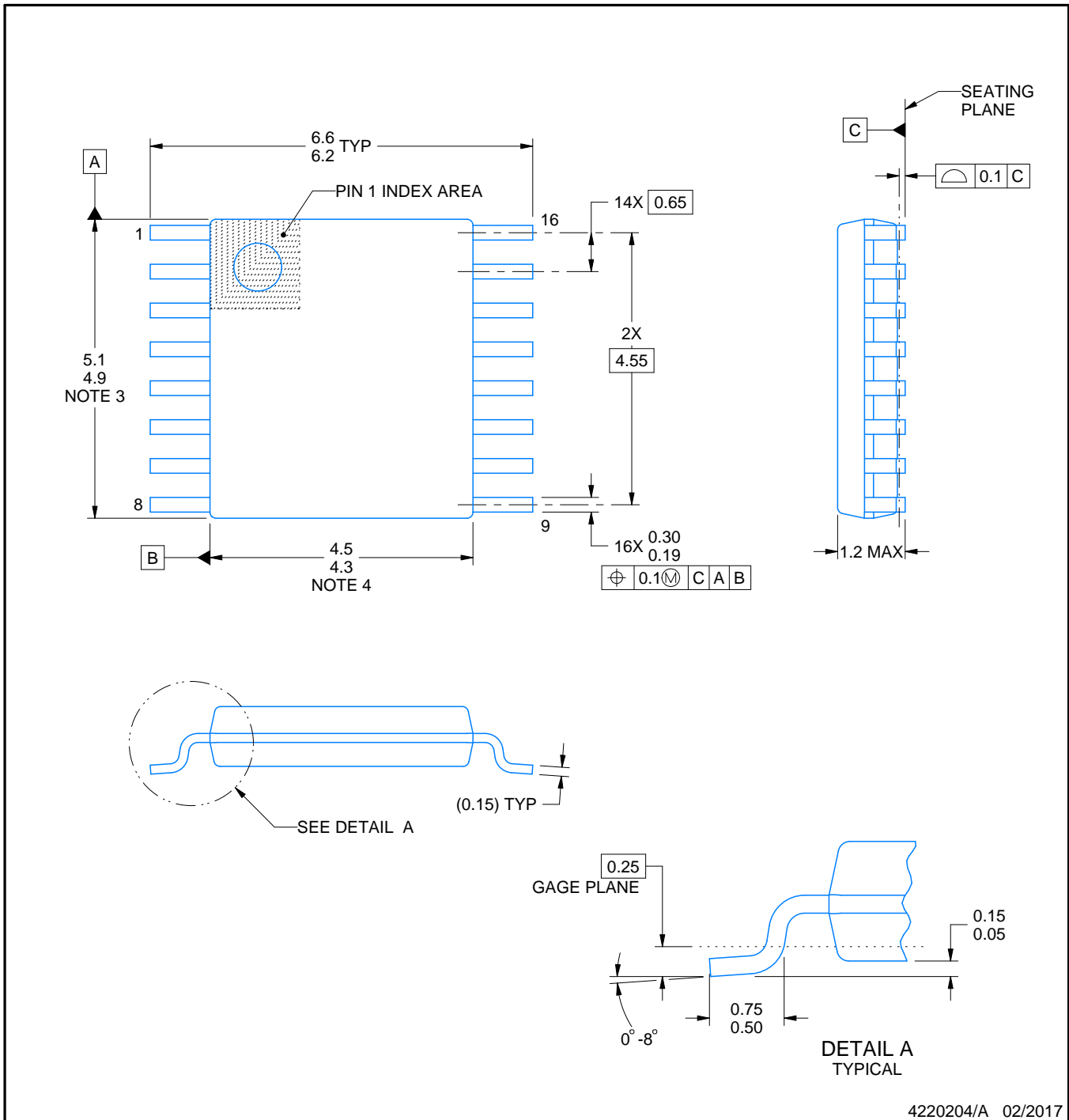

4220204/A 02/2017

NOTES:

1. All linear dimensions are in millimeters. Any dimensions in parenthesis are for reference only. Dimensioning and tolerancing per ASME Y14.5M.
2. This drawing is subject to change without notice.
3. This dimension does not include mold flash, protrusions, or gate burrs. Mold flash, protrusions, or gate burrs shall not exceed 0.15 mm per side.
4. This dimension does not include interlead flash. Interlead flash shall not exceed 0.25 mm per side.
5. Reference JEDEC registration MO-153.

# EXAMPLE BOARD LAYOUT

PW0016A

TSSOP - 1.2 mm max height

SMALL OUTLINE PACKAGE



LAND PATTERN EXAMPLE  
EXPOSED METAL SHOWN  
SCALE: 10X



SOLDER MASK DETAILS

4220204/A 02/2017

NOTES: (continued)

- 6. Publication IPC-7351 may have alternate designs.
- 7. Solder mask tolerances between and around signal pads can vary based on board fabrication site.

# EXAMPLE STENCIL DESIGN

PW0016A

TSSOP - 1.2 mm max height

SMALL OUTLINE PACKAGE

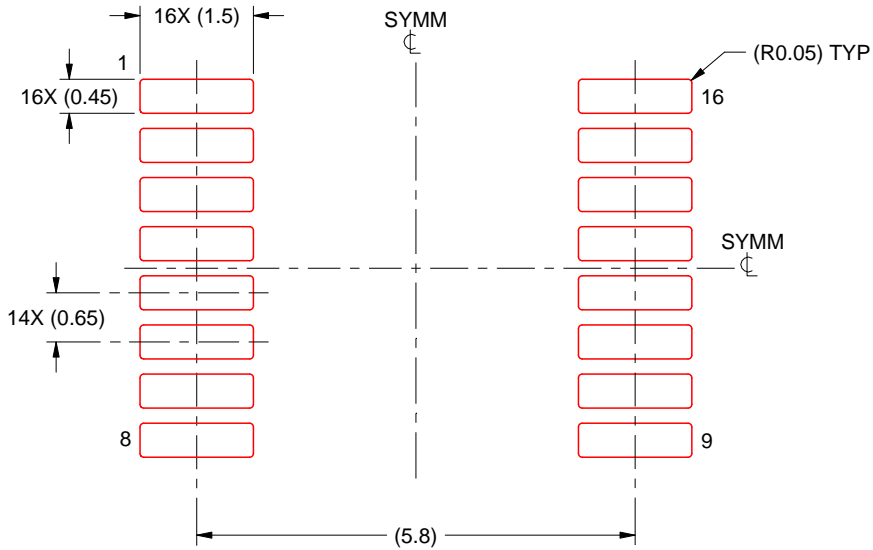

SOLDER PASTE EXAMPLE  
BASED ON 0.125 mm THICK STENCIL  
SCALE: 10X

4220204/A 02/2017

NOTES: (continued)

8. Laser cutting apertures with trapezoidal walls and rounded corners may offer better paste release. IPC-7525 may have alternate design recommendations.
9. Board assembly site may have different recommendations for stencil design.

## MECHANICAL DATA

**NS (R-PDSO-G\*\*)**

**PLASTIC SMALL-OUTLINE PACKAGE**

**14-PINS SHOWN**



- NOTES:
- A. All linear dimensions are in millimeters.
  - B. This drawing is subject to change without notice.
  - C. Body dimensions do not include mold flash or protrusion, not to exceed 0,15.

W (R-GDFP-F16)

CERAMIC DUAL FLATPACK

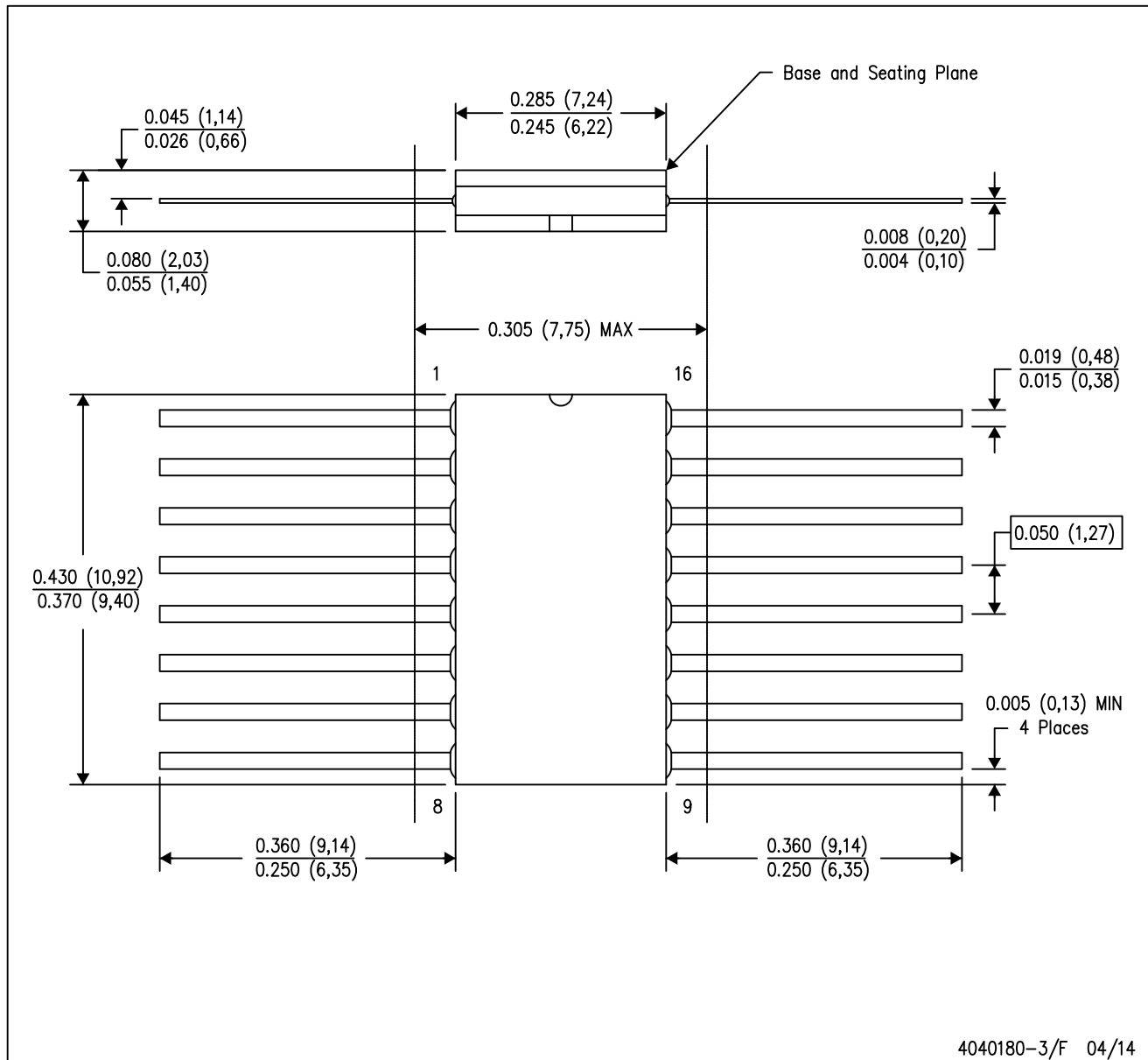

- NOTES:
- A. All linear dimensions are in inches (millimeters).
  - B. This drawing is subject to change without notice.
  - C. This package can be hermetically sealed with a ceramic lid using glass frit.
  - D. Index point is provided on cap for terminal identification only.
  - E. Falls within MIL STD 1835 GDFP2-F16

## GENERIC PACKAGE VIEW

**FK 20**

**LCCC - 2.03 mm max height**

8.89 x 8.89, 1.27 mm pitch

LEADLESS CERAMIC CHIP CARRIER

This image is a representation of the package family, actual package may vary.  
Refer to the product data sheet for package details.

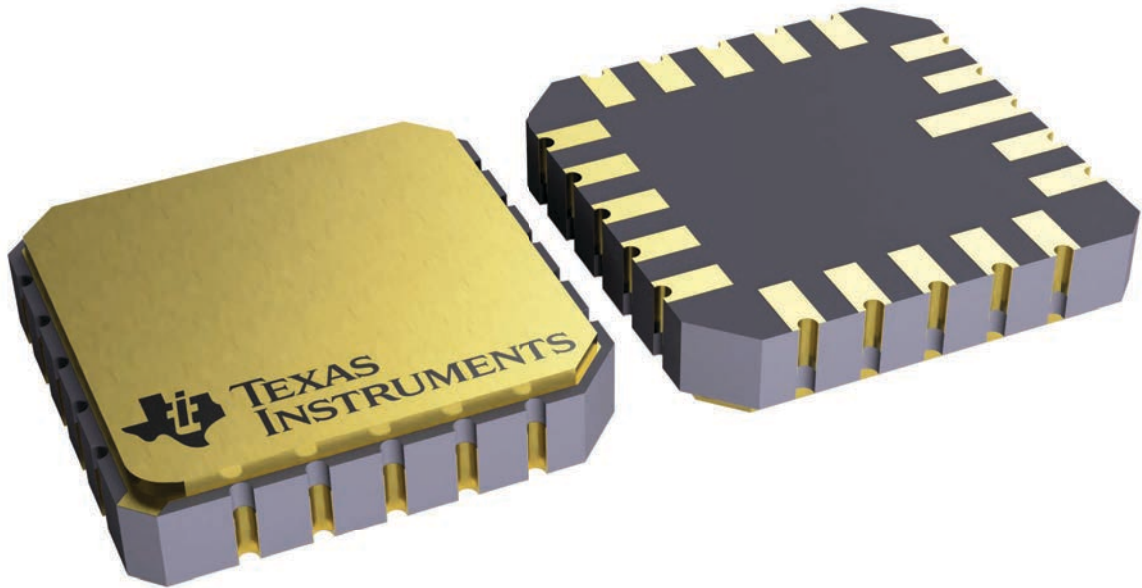

4229370VA\

# J (R-GDIP-T\*\*)

14 LEADS SHOWN

# CERAMIC DUAL IN-LINE PACKAGE

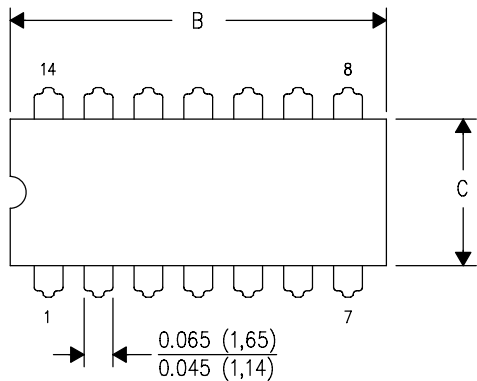

DIM \ PINS **	14	16	18	20
A	0.300 (7,62) BSC	0.300 (7,62) BSC	0.300 (7,62) BSC	0.300 (7,62) BSC
B MAX	0.785 (19,94)	.840 (21,34)	0.960 (24,38)	1.060 (26,92)
B MIN	—	—	—	—
C MAX	0.300 (7,62)	0.300 (7,62)	0.310 (7,87)	0.300 (7,62)
C MIN	0.245 (6,22)	0.245 (6,22)	0.220 (5,59)	0.245 (6,22)



4040083/F 03/03

- NOTES:
- All linear dimensions are in inches (millimeters).
  - This drawing is subject to change without notice.
  - This package is hermetically sealed with a ceramic lid using glass frit.
  - Index point is provided on cap for terminal identification only on press ceramic glass frit seal only.
  - Falls within MIL STD 1835 GDIP1-T14, GDIP1-T16, GDIP1-T18 and GDIP1-T20.

N (R-PDIP-T\*\*)

PLASTIC DUAL-IN-LINE PACKAGE

16 PINS SHOWN



- NOTES:
- A. All linear dimensions are in inches (millimeters).
  - B. This drawing is subject to change without notice.
  - Falls within JEDEC MS-001, except 18 and 20 pin minimum body length (Dim A).
  - The 20 pin end lead shoulder width is a vendor option, either half or full width.

## IMPORTANT NOTICE AND DISCLAIMER

TI PROVIDES TECHNICAL AND RELIABILITY DATA (INCLUDING DATA SHEETS), DESIGN RESOURCES (INCLUDING REFERENCE DESIGNS), APPLICATION OR OTHER DESIGN ADVICE, WEB TOOLS, SAFETY INFORMATION, AND OTHER RESOURCES "AS IS" AND WITH ALL FAULTS, AND DISCLAIMS ALL WARRANTIES, EXPRESS AND IMPLIED, INCLUDING WITHOUT LIMITATION ANY IMPLIED WARRANTIES OF MERCHANTABILITY, FITNESS FOR A PARTICULAR PURPOSE OR NON-INFRINGEMENT OF THIRD PARTY INTELLECTUAL PROPERTY RIGHTS.

These resources are intended for skilled developers designing with TI products. You are solely responsible for (1) selecting the appropriate TI products for your application, (2) designing, validating and testing your application, and (3) ensuring your application meets applicable standards, and any other safety, security, regulatory or other requirements.

These resources are subject to change without notice. TI grants you permission to use these resources only for development of an application that uses the TI products described in the resource. Other reproduction and display of these resources is prohibited. No license is granted to any other TI intellectual property right or to any third party intellectual property right. TI disclaims responsibility for, and you will fully indemnify TI and its representatives against, any claims, damages, costs, losses, and liabilities arising out of your use of these resources.

TI's products are provided subject to [TI's Terms of Sale](#) or other applicable terms available either on [ti.com](https://www.ti.com) or provided in conjunction with such TI products. TI's provision of these resources does not expand or otherwise alter TI's applicable warranties or warranty disclaimers for TI products.

TI objects to and rejects any additional or different terms you may have proposed.

Mailing Address: Texas Instruments, Post Office Box 655303, Dallas, Texas 75265  
Copyright © 2024, Texas Instruments Incorporated

## Looking for pricing, stock, or lifecycle information?

Click below to explore more details on WIN SOURCE:

 [View AM26LS33AMJ](#) on WIN SOURCE

 [Texas Instruments](#) Information

## Optimize Your Supply Chain with WIN SOURCE Solutions

-  Global Sourcing Solution
-  Obsolete Management
-  Cost Control Management
-  Shortage Management
-  Alternative Solution
-  Excess Inventory Management