



**THE DATASHEET OF  
ADUC7124BCPZ126**



### FEATURES

#### Analog input/output

- Multichannel, 12-bit, 1 MSPS ADC
- Up to 16 ADC channels
- Fully differential and single-ended modes
- 0 V to  $V_{REF}$  analog input range
- 12-bit voltage output DACs
- 4 DAC outputs available
- On-chip voltage reference
- On-chip temperature sensor ( $\pm 3^\circ\text{C}$ )
- Voltage comparator

#### Microcontroller

- ARM7TDMI core, 16-bit/32-bit RISC architecture
- JTAG port supports code download and debug

#### Clocking options

- Trimmed on-chip oscillator ( $\pm 3\%$ )
- External watch crystal
- External clock source up to 41.78 MHz
- 41.78 MHz PLL with programmable divider

#### Memory

- 126 kB Flash/EE memory, 32 kB SRAM
- In-circuit download, JTAG-based debug
- Software-triggered in-circuit reprogrammability

#### Vectored interrupt controller for FIQ and IRQ

- 8 priority levels for each interrupt type
- Interrupt on edge or level external pin inputs

#### On-chip peripherals

- 2x fully I<sup>2</sup>C-compatible channels
- SPI (20 MBPS in master mode, 10 MBPS in slave mode)
- With 4-byte FIFO on input and output stages
- 2x UART channels
- With 16-byte FIFO on input and output stages
- Up to 40 GPIO port
- All GPIOs are 5 V tolerant
- 4x general-purpose timers
- Watchdog timer (WDT) and wake-up timer
- Programmable logic array (PLA)
- 16 PLA elements
- 16-bit, 6-channel PWM
- Power supply monitor

#### Power

- Specified for 3 V operation
- Active mode: 11.6 mA at 5 MHz, 33.3 mA at 41.78 MHz

#### Packages and temperature range

- Fully specified for  $-40^\circ\text{C}$  to  $+125^\circ\text{C}$  operation
- 64-lead LFCSP (ADuC7124) and 80-lead LQFP (ADuC7126)

#### Tools

- Low cost QuickStart development system
- Full third-party support

### APPLICATIONS

- Industrial control and automation systems
- Smart sensors, precision instrumentation
- Base station systems, optical networking
- Patient monitoring

### FUNCTIONAL BLOCK DIAGRAM

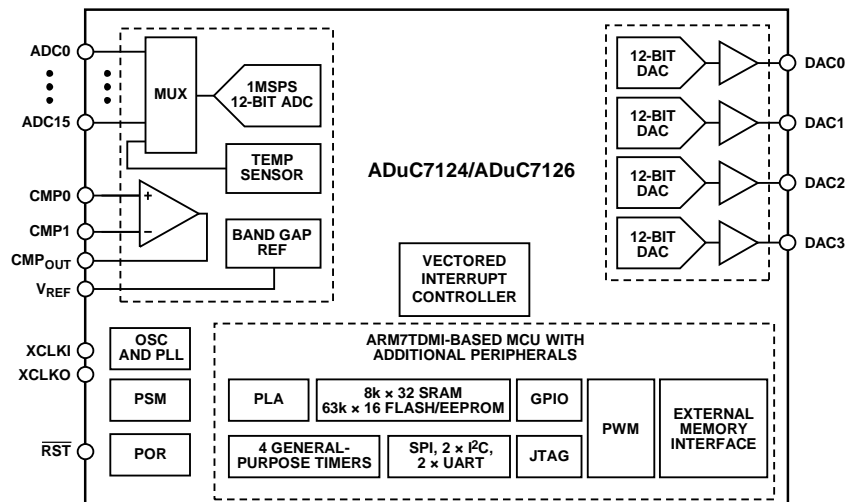

Figure 1.

Rev. D

[Document Feedback](#)

Information furnished by Analog Devices is believed to be accurate and reliable. However, no responsibility is assumed by Analog Devices for its use, nor for any infringements of patents or other rights of third parties that may result from its use. Specifications subject to change without notice. No license is granted by implication or otherwise under any patent or patent rights of Analog Devices. Trademarks and registered trademarks are the property of their respective owners.

One Technology Way, P.O. Box 9106, Norwood, MA 02062-9106, U.S.A.  
 Tel: 781.329.4700 ©2010–2014 Analog Devices, Inc. All rights reserved.  
[Technical Support](#) [www.analog.com](http://www.analog.com)

## TABLE OF CONTENTS

Features .....	1	Band Gap Reference.....	45
Applications.....	1	Nonvolatile Flash/EE Memory .....	46
Functional Block Diagram .....	1	Programming.....	46
Revision History .....	3	Flash/EE Memory Security .....	47
General Description .....	5	Flash/EE Control Interface .....	47
Specifications.....	6	Execution Time from SRAM and Flash/EE.....	50
Timing Specifications .....	9	Reset and Remap .....	50
Absolute Maximum Ratings.....	14	Other Analog Peripherals.....	53
ESD Caution.....	14	DAC.....	53
Pin Configurations and Function Descriptions .....	15	Power Supply Monitor .....	55
Typical Performance Characteristics .....	24	Comparator .....	55
Terminology .....	27	Oscillator and PLL—Power Control.....	56
ADC Specifications .....	27	Digital Peripheral .....	60
DAC Specifications.....	27	General-Purpose Input/Output.....	60
Overview of the ARM7TDMI Core .....	28	Serial Port Mux.....	62
Thumb Mode (T).....	28	UART Serial Interface.....	62
Long Multiply (M).....	28	Serial Peripheral Interface.....	68
EmbeddedICE (I) .....	28	I <sup>2</sup> C.....	72
Exceptions .....	28	PWM General Overview.....	80
ARM Registers .....	28	Programmable Logic Array (PLA).....	83
Interrupt Latency.....	29	Processor Reference Peripherals.....	86
Memory Organization .....	30	Interrupt System.....	86
Memory Access.....	30	IRQ .....	86
Flash/EE Memory.....	30	Fast Interrupt Request (FIQ) .....	87
SRAM.....	30	Vectored Interrupt Controller (VIC).....	88
Memory Mapped Registers .....	30	Timers.....	93
ADC Circuit Overview .....	38	External Memory Interfacing .....	99
Transfer Function .....	38	Hardware Design Considerations .....	103
Typical Operation.....	39	Power Supplies.....	103
MMRs Interface.....	39	Grounding and Board Layout Recommendations.....	104
Converter Operation.....	41	Clock Oscillator .....	104
Driving the Analog Inputs .....	43	Power-On Reset Operation.....	105
Calibration.....	44	Outline Dimensions .....	106
Temperature Sensor .....	44	Ordering Guide .....	107

**REVISION HISTORY****10/14—Rev. C to Rev. D**

Change $\overline{\text{CONV}}_{\text{START}}$ To $\text{CONV}_{\text{START}}$ .....	Universal
Changes to Features Section .....	1
Changes to Pin 17 and Pin 30 Descriptions; Table 10.....	19
Changes to Flash/EE Memory Section and SRAM Section.....	30
Changes to Table 13 .....	32
Changes to Flash/EE Memory Section, Programming Section, and Serial Downloading (In-Circuit Programming) Section ...	46
Changes to Flash/EE Memory Security Section.....	47
Changes to Table 56 and Table 57 .....	50
Changes to Table 69 .....	56
Changes to Table 78 .....	60
Changes to I <sup>2</sup> C Section .....	72
Update Table 102 .....	73
Update Table 109 .....	76
Changes to Table 110 .....	77
Changes to T1CAP Register .....	96

**5/12—Rev. B to Rev. C**

Changed bit to byte in General Description Section.....	4
Changes to Table 2 and Table 3 .....	8
Changes to Table 4 and to Figure 2 and Figure 3.....	9
Changes to Table 5 and Figure 4.....	10
Changes to Table 6 and Figure 5.....	11
Changes Table 7 and Figure 6.....	12
Changes to Pin 50 and Pin 51 in Table 9.....	14
Changes to Serial Downloading (In-Circuit Programming) Section.....	44
Changes to Table 77 .....	59
Changes to Table 78 .....	58
Changes to Table 90 .....	60
Changes to Normal 450 UART Baud Rate Generation Section.....	61
Changes to Serial Peripheral Interface Section .....	66
Added equation to Timers Section and added Hr: Min: Sec 1/128 Format Section.....	91
Changes to Figure 69 .....	103
Updated Outline Dimensions.....	104
Changes to Ordering Guide.....	105

**1/11—Rev A to Rev B**

Changes to Table 1 .....	5
--------------------------	---

**10/10—Rev. 0 to Rev. A**

Added ADuC7126.....	Universal
Changes to Features Section .....	1
Moved Figure 1 .....	1
Changes to Figure 1.....	1
Changes to General Description Section .....	4
Changes to Voltage Output at 25°C, Voltage TC, IOV <sub>DD</sub> Current in Active Mode, and IOV <sub>DD</sub> Current in Pause Mode Parameters, Table 1 .....	5
Change to Table 8 .....	13
Changed REF <sub>GND</sub> to GND <sub>REF</sub> .....	13

Changes to Figure 7 and Table 9 .....	14
Added Figure 8 and Table 10; Renumbered Sequentially.....	18
Change to Figure 17 Caption.....	25
Change to Memory Mapped Registers Section.....	29
Change to Figure 26 .....	30
Changes to Table 18 .....	32
Changes to Table 21 .....	33
Changes to Table 22 .....	34
Moved Table 25.....	35
Change to Table 25.....	35
Added Table 26 .....	35
Change to Table 27.....	36
Changes to Temperature Sensor Section .....	42
Deleted Table 59; Renumbered Sequentially .....	43
Added Downloading (In-Circuit Programming) via I <sup>2</sup> C Section .....	44
Change to JTAG Access Section and Table 37.....	45
Changes to Table 45 .....	46
Changes to RSTCFG Register Section.....	49
Deleted Table 72 and Table 75.....	49
Deleted Table 78 .....	50
Changes to DAC Section, Table 62, and Table 64.....	51
Changes to References to ADC and the DACs Section, Table 66, Configuring DAC Buffers in Op Amp Mode Section, DACBCFG Register Section, and Table 67 .....	52
Added DACBKEY1 Register Section and DACBKEY2 Register Section .....	53
Changes to Table 69 and Figure 45 .....	54
Changes to and External Crystal Selection and External Clock Selection .....	55
Changes to PLLCON Register and POWCON0 Register Section .....	56
Changes to Table 78 .....	58
Changes to Table 81 .....	59
Changes to Table 84 and Table 90.....	60
Changes to Table 93, COM0FCR Register Section, COM1FCR Register Section, and Table 94.....	63
Changes to Serial Peripheral Interface Section .....	66
Change to SPI Registers Section.....	67
Changes to SPIDIV Register Section and Table 101 .....	68
Change to I <sup>2</sup> C Master Transmit Register Section .....	73
Change to Table 109.....	74
Change to I <sup>2</sup> C Slave Status Registers Section.....	75
Change to Table 113.....	79
Changes to Table 114 Title and Figure 50.....	80
Change to IRQCLRE Register Register .....	90
Change to Figure 54.....	92
Changes to Table 141, T1CLRI Register Section, and T1CAP Register Section .....	93
Changes to Table 143 .....	94
Added External Memory Interfacing Section, Table 145, Table 146, and Figure 57.....	96

Added XMCFG Register Section, Table 147, Table 148,  
Table 149, and Table 150..... 97  
Added Figure 58 and Figure 59..... 98  
Added Figure 60 and Figure 61..... 99  
Changes to Figure 62 to Figure 65..... 100  
Changes to Figure 67 and Figure 68..... 101

Change to Power-On Reset Operation Section and  
Figure 69 ..... 102  
Added Figure 71 ..... 103  
Changes to Ordering Guide ..... 104

**9/10—Revision 0: Initial Version**

## GENERAL DESCRIPTION

The [ADuC7124/ADuC7126](#) are fully integrated, 1 MSPS, 12-bit data acquisition system incorporating high performance multichannel ADCs, 16-bit/32-bit MCUs, and Flash/EE memory on a single chip.

The ADC consists of up to 12 single-ended inputs. An additional four inputs are available but are multiplexed with the four DAC output pins. The ADC can operate in single-ended or differential input mode. The ADC input voltage range is 0 V to VREF. A low drift band gap reference, temperature sensor, and voltage comparator complete the ADC peripheral set.

The DAC output range is programmable to one of three voltage ranges. The DAC outputs have an enhanced feature of being able to retain their output voltage during a watchdog or software reset sequence.

The devices operate from an on-chip oscillator and a PLL generating an internal high frequency clock of 41.78 MHz. This clock is routed through a programmable clock divider from which the MCU core clock operating frequency is generated. The microcontroller core is an ARM7TDMI®, 16-bit/32-bit RISC machine, which offers up to 41 MIPS of peak performance. Thirty-two kilobytes of SRAM and 126 kB of nonvolatile Flash/EE memory are provided on-chip. The ARM7TDMI core views all memory and registers as a single linear array.

The [ADuC7124/ADuC7126](#) contain an advanced interrupt controller. The vectored interrupt controller (VIC) allows every interrupt to be assigned a priority level. It also supports nested interrupts to a maximum level of eight per IRQ and FIQ. When IRQ and FIQ interrupt sources are combined, a total of 16 nested interrupt levels are supported.

On-chip factory firmware supports in-circuit download via the UART serial interface port or the I<sup>2</sup>C port, while nonintrusive emulation is also supported via the JTAG interface. These features are incorporated into a low cost QuickStart™ development system supporting this MicroConverter® family.

The parts contain a 16-bit PWM with six output signals.

For communication purposes, the parts contain 2× I<sup>2</sup>C channels that can be individually configured for master or slave mode. An SPI interface supporting both master and slave modes is also provided. Thirdly, 2× UART channels are provided. Each UART contains a configurable 16-byte FIFO with receive and transmit buffers.

The parts operate from 2.7 V to 3.6 V and is specified over an industrial temperature range of –40°C to +125°C. When operating at 41.78 MHz, the power dissipation is typically 120 mW. The [ADuC7124](#) is available in a 64-lead LFCSP package. The [ADuC7126](#) is available in a 80-lead LQFP package.

## SPECIFICATIONS

$V_{DD} = IOV_{DD} = 2.7\text{ V to }3.6\text{ V}$ ,  $V_{REF} = 2.5\text{ V}$  internal reference,  $f_{CORE} = 41.78\text{ MHz}$ ,  $T_A = -40^\circ\text{C to }+125^\circ\text{C}$ , unless otherwise noted.

Table 1.

Parameter	Min	Typ	Max	Unit	Test Conditions/Comments
<b>ADC CHANNEL SPECIFICATIONS</b>					
ADC Power-Up Time		5		$\mu\text{s}$	Eight acquisition clocks and $f_{ADC}/2$  2.5 V internal reference 1.0 V external reference 2.5 V internal reference 1.0 V external reference ADC input is a dc voltage
DC Accuracy <sup>1,2</sup>					
Resolution	12			Bits	
Integral Nonlinearity		$\pm 0.6$	$\pm 1.5$	LSB	
		$\pm 1.0$		LSB	
Differential Nonlinearity <sup>3,4</sup>		$\pm 0.5$	$+1/-0.9$	LSB	
		$+0.7/-0.6$		LSB	
DC Code Distribution		1		LSB	
<b>ENDPOINT ERRORS<sup>5</sup></b>					
Offset Error		$\pm 1$	$\pm 2$	LSB	
Offset Error Match		$\pm 1$		LSB	
Gain Error		$\pm 2$	$\pm 5$	LSB	
Gain Error Match		$\pm 1$		LSB	
<b>DYNAMIC PERFORMANCE</b>					
Signal-to-Noise Ratio (SNR)		69		dB	$f_{IN} = 10\text{ kHz sine wave}$ , $f_{SAMPLE} = 1\text{ MSPS}$ Includes distortion and noise components  Measured on adjacent channels; input channels not being sampled have a 25 kHz sine wave connected to them
Total Harmonic Distortion (THD)		-78		dB	
Peak Harmonic or Spurious Noise		-75		dB	
Channel-to-Channel Crosstalk		-90		dB	
<b>ANALOG INPUT</b>					
Input Voltage Ranges <sup>4</sup>					During ADC acquisition
Differential Mode			$V_{CM}^6 \pm V_{REF}/2$	V	
Single-Ended Mode			0 to $V_{REF}$	V	
Leakage Current		$\pm 1$	$\pm 6$	$\mu\text{A}$	
Input Capacitance		24		pF	
<b>ON-CHIP VOLTAGE REFERENCE</b>					
Output Voltage		2.5		V	0.47 $\mu\text{F}$ from $V_{REF}$ to AGND  $T_A = 25^\circ\text{C}$  $T_A = 25^\circ\text{C}$
Accuracy			$\pm 5$	mV	
Reference Temperature Coefficient		$\pm 15$		ppm/ $^\circ\text{C}$	
Power Supply Rejection Ratio		80		dB	
Output Impedance		45		$\Omega$	
Internal $V_{REF}$ Power-On Time		1		ms	
<b>EXTERNAL REFERENCE INPUT</b>					
Input Voltage Range	0.625		$V_{DD}$	V	
<b>DAC CHANNEL SPECIFICATIONS</b>					
DC Accuracy <sup>7</sup>					$R_L = 5\text{ k}\Omega$ , $C_L = 100\text{ pF}$  Guaranteed monotonic 2.5 V internal reference  % of full scale on DAC0
Resolution		12		Bits	
Relative Accuracy		$\pm 2$		LSB	
Differential Nonlinearity			$\pm 1$	LSB	
Offset Error			10	mV	
Gain Error <sup>8</sup>			1.0	%	
Gain Error Mismatch		0.1		%	

Parameter	Min	Typ	Max	Unit	Test Conditions/Comments
<b>ANALOG OUTPUTS</b>					
Output Voltage Range 0		0 to DAC <sub>REF</sub>		V	DAC <sub>REF</sub> range: DACGND to DACV <sub>DD</sub>
Output Voltage Range 1		0 to 2.5		V	
Output Voltage Range 2		0 to DACV <sub>DD</sub>		V	
Output Impedance		0.5		Ω	
<b>DAC IN OP AMP MODE</b>					
DAC Output Buffer in Op Amp Mode					
Input Offset Voltage		±0.4		mV	
Input Offset Voltage Drift		4		μV/°C	
Input Offset Current		2		nA	
Input Bias Current		2.5		nA	
Gain		70		dB	5 kΩ load
Unity Gain Frequency		4.5		MHz	R <sub>L</sub> = 5 kΩ, C <sub>L</sub> = 100 pF
CMRR		78		dB	
Settling Time		12		μs	R <sub>L</sub> = 5 kΩ, C <sub>L</sub> = 100 pF
Output Slew Rate		3.2		V/μs	R <sub>L</sub> = 5 kΩ, C <sub>L</sub> = 100 pF
PSRR		75		dB	
<b>DAC AC CHARACTERISTICS</b>					
Voltage Output Settling Time		10		μs	1 LSB change at major carry (where maximum number of bits simultaneously change in the DACxDAT register)
Digital-to-Analog Glitch Energy		±10		nV-sec	
<b>COMPARATOR</b>					
Input Offset Voltage		±15		mV	Hysteresis can be turned on or off via the CMPHYST bit in the CMPCON register 100 mV overdrive and configured with CMPRES = 11
Input Bias Current		1		μA	
Input Voltage Range	AGND		AV <sub>DD</sub> - 1.2	V	
Input Capacitance		8.5		pF	
Hysteresis <sup>4,6</sup>	2		15	mV	
Response Time		4		μs	
<b>TEMPERATURE SENSOR</b>					
Voltage Output at 25°C		1.415		V	ADuC7124
		1.392		V	ADuC7126
Voltage Temperature Coefficient		3.914		mV/°C	ADuC7124
		4.52		mV/°C	ADuC7126
Accuracy		±3		°C	A single point calibration is required
θ <sub>JA</sub> Thermal Impedance					
64-Lead LFCS		24		°C/W	
<b>POWER SUPPLY MONITOR (PSM)</b>					
IOV <sub>DD</sub> Trip Point Selection		2.79		V	Two selectable trip points
		3.07		V	
Power Supply Trip Point Accuracy		±2.5		%	Of the selected nominal trip point voltage
<b>POWER-ON RESET</b>					
		2.41		V	
<b>WATCHDOG TIMER (WDT)</b>					
Timeout Period	0		512	sec	
<b>FLASH/EE MEMORY</b>					
Endurance <sup>9</sup>	10,000			Cycles	T <sub>J</sub> = 85°C
Data Retention <sup>10</sup>	20			Years	
<b>DIGITAL INPUTS</b>					
Logic 1 Input Current		±0.2	±1	μA	All digital inputs excluding XCLKI and XCLKO V <sub>IH</sub> = V <sub>DD</sub> or V <sub>IH</sub> = 5 V
Logic 0 Input Current		-40	-60	μA	V <sub>IL</sub> = 0 V; except TDI, TDO, and RTCK
		-80	-120	μA	V <sub>IL</sub> = 0 V; TDI, TDO, and RTCK
Input Capacitance		5		pF	

Parameter	Min	Typ	Max	Unit	Test Conditions/Comments
LOGIC INPUTS <sup>3</sup>					All logic inputs excluding XCLKI
V <sub>INL</sub> , Input Low Voltage			0.8	V	
V <sub>INH</sub> , Input High Voltage	2.0			V	
LOGIC OUTPUTS					All digital outputs excluding XCLKO
V <sub>OH</sub> , Output High Voltage	2.4			V	I <sub>SOURCE</sub> = 1.6 mA
V <sub>OL</sub> , Output Low Voltage <sup>11</sup>			0.4	V	I <sub>SINK</sub> = 1.6 mA
CRYSTAL INPUTS XCLKI and XCLKO					
Logic Inputs, XCLKI Only					
V <sub>INL</sub> , Input Low Voltage		0.8		V	
V <sub>INH</sub> , Input High Voltage		1.6		V	
XCLKI Input Capacitance		20		pF	
XCLKO Output Capacitance		20		pF	
INTERNAL OSCILLATOR		32.768		kHz	
			±3	%	
MCU CLOCK RATE <sup>4</sup>					
From 32 kHz Internal Oscillator		326		kHz	CD = 7
From 32 kHz External Crystal		41.78		MHz	CD = 0
Using an External Clock	0.05		44	MHz	T <sub>A</sub> = 85°C
	0.05		41.78	MHz	T <sub>A</sub> = 125°C
START-UP TIME					Core clock = 41.78 MHz
At Power-On		66		ms	
From Pause/Nap Mode		2.6		μs	CD = 0
		247		μs	CD = 7
From Sleep Mode		1.58		ms	
From Stop Mode		1.7		ms	
PROGRAMMABLE LOGIC ARRAY (PLA)					
Pin Propagation Delay		12		ns	From input pin to output pin
Element Propagation Delay		2.5		ns	
POWER REQUIREMENTS <sup>12,13</sup>					
Power Supply Voltage Range					
AV <sub>DD</sub> to AGND and IOV <sub>DD</sub> to IOGND	2.7		3.6	V	
Analog Power Supply Currents					
AV <sub>DD</sub> Current		165		μA	ADC in idle mode
DACV <sub>DD</sub> Current <sup>14</sup>		0.02		μA	
Digital Power Supply Current					
IOV <sub>DD</sub> Current in Active Mode		8.1	12.5	mA	Code executing from Flash/EE
		11.6	17	mA	CD = 7
		33.3	50	mA	CD = 3
IOV <sub>DD</sub> Current in Pause Mode		20.6	30	mA	CD = 0 (41.78 MHz clock)
IOV <sub>DD</sub> Current in Sleep Mode		110		μA	CD = 0 (41.78 MHz clock)
		600	680	μA	T <sub>A</sub> = 85°C
					T <sub>A</sub> = 125°C
Additional Power Supply Currents					
ADC		1.26		mA	At 1 MSPS
		0.7		mA	At 62.5 kSPS
DAC		315		μA	Per DAC

Parameter	Min	Typ	Max	Unit	Test Conditions/Comments
ESD TESTS					
HBM Passed Up To			3	kV	2.5 V reference, T <sub>A</sub> = 25°C
FICDM Passed Up To			1.5	kV	

<sup>1</sup> All ADC channel specifications are guaranteed during normal core operation.

<sup>2</sup> Apply to all ADC input channels.

<sup>3</sup> Measured using the factory-set default values in the ADC offset register (ADCOF) and gain coefficient register (ADCGN).

<sup>4</sup> Not production tested but supported by design and/or characterization data on production release.

<sup>5</sup> Measured using the factory-set default values in ADCOF and ADCGN with an external AD845 op amp as an input buffer stage as shown in Figure 37. Based on external ADC system components, the user may need to execute a system calibration to remove external endpoint errors and achieve these specifications (see the Calibration section).

<sup>6</sup> The input signal can be centered on any dc common-mode voltage (V<sub>CM</sub>) as long as this value is within the ADC voltage input range specified.

<sup>7</sup> DAC linearity is calculated using a reduced code range of 100 to 3995.

<sup>8</sup> DAC gain error is calculated using a reduced code range of 100 to internal 2.5 V V<sub>REF</sub>.

<sup>9</sup> Endurance is qualified as per JEDEC Standard 22 Method A117 and measured at -40°C, +25°C, +85°C, and +125°C.

<sup>10</sup> Retention lifetime equivalent at junction temperature (T<sub>J</sub>) = 85°C as per JEDEC Standard 22 Method A117. Retention lifetime derates with junction temperature.

<sup>11</sup> Test carried out with a maximum of eight I/Os set to a low output level.

<sup>12</sup> Power supply current consumption is measured in normal, pause, and sleep modes under the following conditions: normal mode with 3.6 V supply, pause mode with 3.6 V supply, and sleep mode with 3.6 V supply.

<sup>13</sup> I/O<sub>DD</sub> power supply current increases typically by 2 mA during a Flash/EE erase cycle.

<sup>14</sup> This current must be added to the AV<sub>DD</sub> current.

## TIMING SPECIFICATIONS

### I<sup>2</sup>C Timing

Table 2. I<sup>2</sup>C Timing in Fast Mode (400 kHz)

Parameter	Description	Slave		Master	Unit
		Min	Max	Typ	
t <sub>L</sub>	SCL low pulse width	200		1360	ns
t <sub>H</sub>	SCL high pulse width	100		1140	ns
t <sub>SHD</sub>	Start condition hold time	300			ns
t <sub>DSU</sub>	Data setup time	100		740	ns
t <sub>DHD</sub>	Data hold time	0		400	ns
t <sub>RSU</sub>	Setup time for repeated start	100			ns
t <sub>PSU</sub>	Stop condition setup time	100		800	ns
t <sub>BUF</sub>	Bus-free time between a stop condition and a start condition	1.3			μs
t <sub>R</sub>	Rise time for both SCL and SDA		300	200	ns
t <sub>F</sub>	Fall time for both SCL and SDA		300		ns

Table 3. I<sup>2</sup>C Timing in Standard Mode (100 kHz)

Parameter	Description	Slave		Unit
		Min	Max	
t <sub>L</sub>	SCL low pulse width	4.7		μs
t <sub>H</sub>	SCL high pulse width	4.0		ns
t <sub>SHD</sub>	Start condition hold time	4.0		μs
t <sub>DSU</sub>	Data setup time	250		ns
t <sub>DHD</sub>	Data hold time	0	3.45	μs
t <sub>RSU</sub>	Setup time for repeated start	4.7		μs
t <sub>PSU</sub>	Stop condition setup time	4.0		μs
t <sub>BUF</sub>	Bus-free time between a stop condition and a start condition	4.7		μs
t <sub>R</sub>	Rise time for both SCL and SDA		1	μs
t <sub>F</sub>	Fall time for both SCL and SDA		300	ns

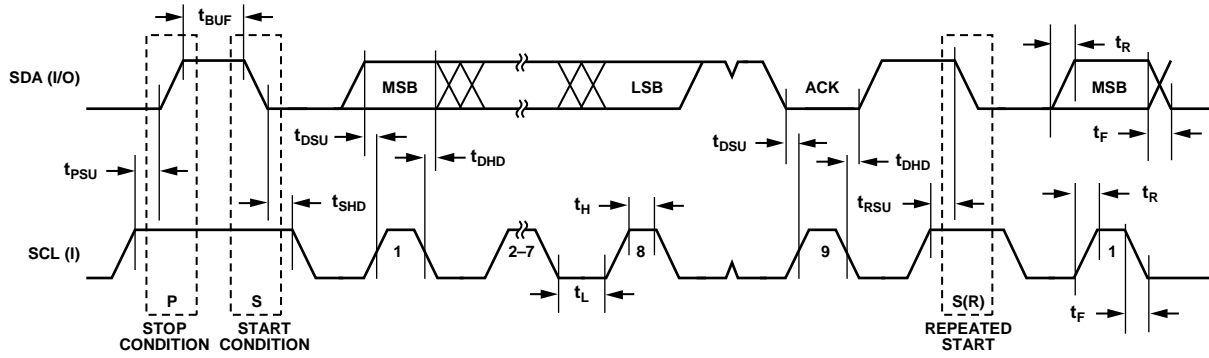

Figure 2. I<sup>2</sup>C-Compatible Interface Timing

SPI Timing

Table 4. SPI Master Mode Timing (Phase Mode = 1)

Parameter	Description	Min	Typ	Max	Unit
t <sub>SL</sub>	SCLK low pulse width <sup>1</sup>		(SPIDIV + 1) × t <sub>UCLK</sub>		ns
t <sub>SH</sub>	SCLK high pulse width <sup>1</sup>		(SPIDIV + 1) × t <sub>UCLK</sub>		ns
t <sub>DAV</sub>	Data output valid after SCLK edge			25	ns
t <sub>DSU</sub>	Data input setup time before SCLK edge <sup>1</sup>	1 × t <sub>UCLK</sub>			ns
t <sub>DHD</sub>	Data input hold time after SCLK edge <sup>1</sup>	2 × t <sub>UCLK</sub>			ns
t <sub>DF</sub>	Data output fall time		5	12.5	ns
t <sub>DR</sub>	Data output rise time		5	12.5	ns
t <sub>SR</sub>	SCLK rise time		5	12.5	ns
t <sub>SF</sub>	SCLK fall time		5	12.5	ns

<sup>1</sup> t<sub>UCLK</sub> = 23.9 ns. It corresponds to the 41.78 MHz internal clock from the PLL before the clock divider.

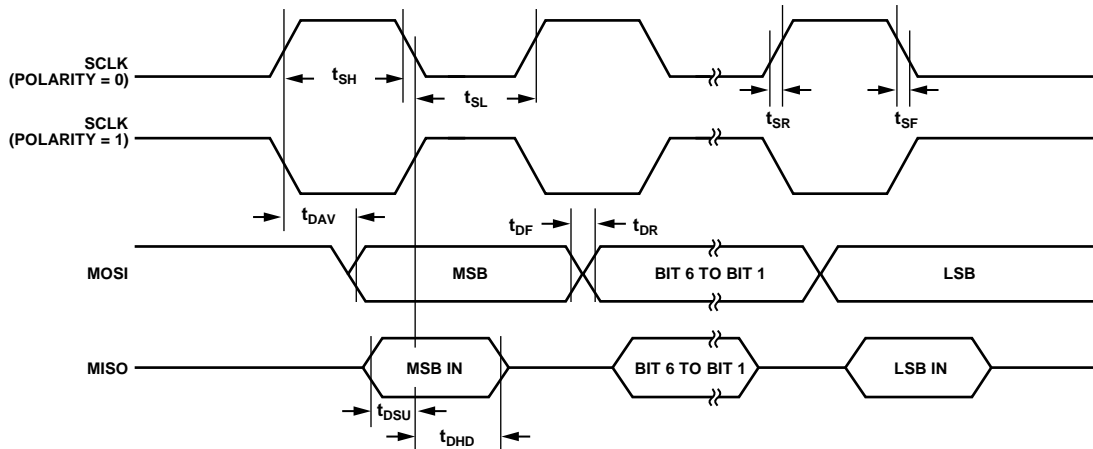

Figure 3. SPI Master Mode Timing (Phase Mode = 1)

Table 5. SPI Master Mode Timing (Phase Mode = 0)

Parameter	Description	Min	Typ	Max	Unit
$t_{SL}$	SCLK low pulse width <sup>1</sup>		$(SPIDIV + 1) \times t_{UCLK}$		ns
$t_{SH}$	SCLK high pulse width <sup>1</sup>		$(SPIDIV + 1) \times t_{UCLK}$		ns
$t_{DAV}$	Data output valid after SCLK edge			25	ns
$t_{DOSU}$	Data output setup before SCLK edge			75	ns
$t_{DSU}$	Data input setup time before SCLK edge <sup>1</sup>	$1 \times t_{UCLK}$			ns
$t_{DHD}$	Data input hold time after SCLK edge <sup>1</sup>	$2 \times t_{UCLK}$			ns
$t_{DF}$	Data output fall time		5	12.5	ns
$t_{DR}$	Data output rise time		5	12.5	ns
$t_{SR}$	SCLK rise time		5	12.5	ns
$t_{SF}$	SCLK fall time		5	12.5	ns

<sup>1</sup>  $t_{UCLK} = 23.9$  ns. It corresponds to the 41.78 MHz internal clock from the PLL before the clock divider.

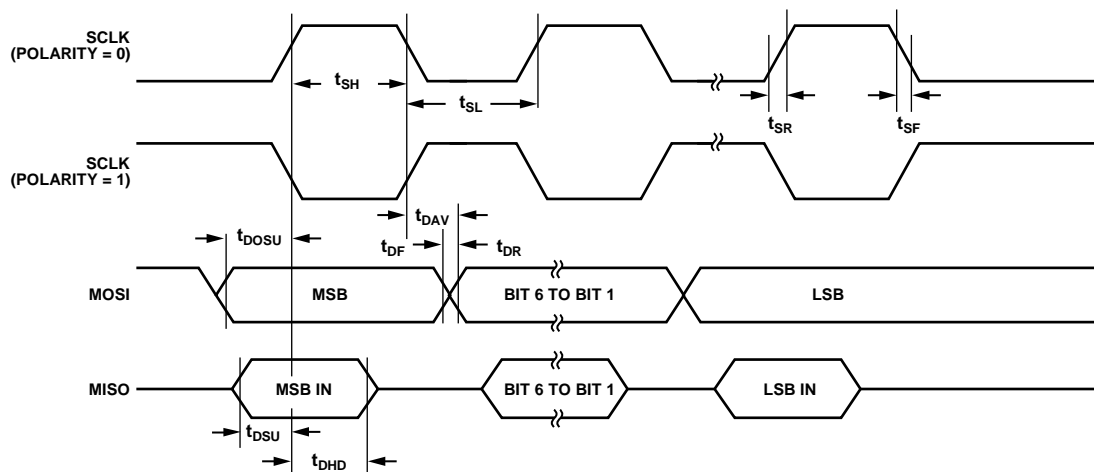

Figure 4. SPI Master Mode Timing (Phase Mode = 0)

09123-031

Table 6. SPI Slave Mode Timing (Phase Mode = 1)

Parameter	Description	Min	Typ	Max	Unit
$t_{\overline{CS}}$	$\overline{CS}$ to SCLK edge	200			ns
$t_{SL}$	SCLK low pulse width		$(SPIDIV + 1) \times t_{HCLK}$		ns
$t_{SH}$	SCLK high pulse width		$(SPIDIV + 1) \times t_{HCLK}$		ns
$t_{DAV}$	Data output valid after SCLK edge			25	ns
$t_{DSU}$	Data input setup time before SCLK edge <sup>1</sup>	$1 \times t_{UCLK}$			ns
$t_{DHD}$	Data input hold time after SCLK edge <sup>1</sup>	$2 \times t_{UCLK}$			ns
$t_{DF}$	Data output fall time		5	12.5	ns
$t_{DR}$	Data output rise time		5	12.5	ns
$t_{SR}$	SCLK rise time		5	12.5	ns
$t_{SF}$	SCLK fall time		5	12.5	ns
$t_{SFS}$	$\overline{CS}$ high after SCLK edge	0			ns

<sup>1</sup>  $t_{UCLK} = 23.9$  ns. It corresponds to the 41.78 MHz internal clock from the PLL before the clock divider.

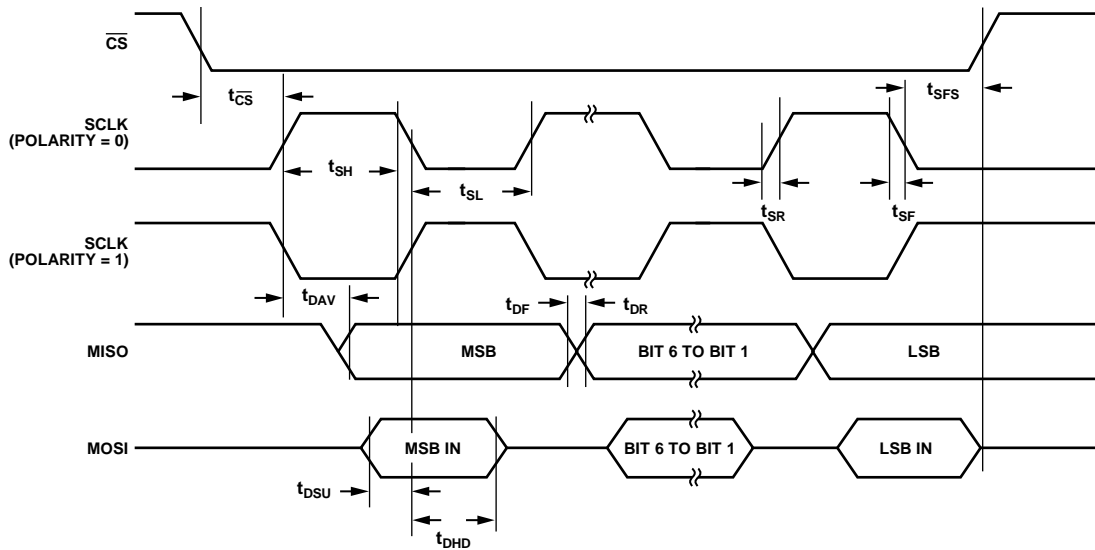

Figure 5. SPI Slave Mode Timing (Phase Mode = 1)

09123132

Table 7. SPI Slave Mode Timing (Phase Mode = 0)

Parameter	Description	Min	Typ	Max	Unit
$t_{\overline{CS}}$	$\overline{CS}$ to SCLK edge	200			ns
$t_{SL}$	SCLK low pulse width		$(SPIDIV + 1) \times t_{HCLK}$		ns
$t_{SH}$	SCLK high pulse width		$(SPIDIV + 1) \times t_{HCLK}$		ns
$t_{DAV}$	Data output valid after SCLK edge			25	ns
$t_{DSU}$	Data input setup time before SCLK edge <sup>1</sup>	$1 \times t_{UCLK}$			ns
$t_{DHD}$	Data input hold time after SCLK edge <sup>1</sup>	$2 \times t_{UCLK}$			ns
$t_{DF}$	Data output fall time		5	12.5	ns
$t_{DR}$	Data output rise time		5	12.5	ns
$t_{SR}$	SCLK rise time		5	12.5	ns
$t_{SF}$	SCLK fall time		5	12.5	ns
$t_{DOCS}$	Data output valid after $\overline{CS}$ edge			25	ns
$t_{SFS}$	$\overline{CS}$ high after SCLK edge	0			ns

<sup>1</sup>  $t_{UCLK} = 23.9$  ns. It corresponds to the 41.78 MHz internal clock from the PLL before the clock divider.

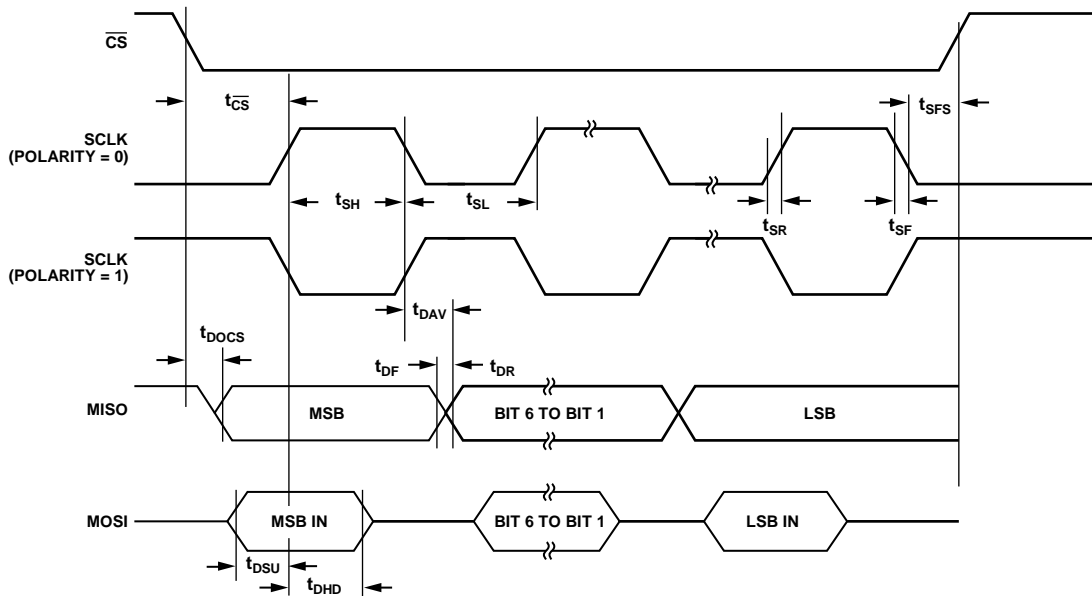

Figure 6. SPI Slave Mode Timing (Phase Mode = 0)

09123-033

## ABSOLUTE MAXIMUM RATINGS

AGND = GND<sub>REF</sub> = DACGND = GND<sub>REF</sub>, T<sub>A</sub> = 25°C, unless otherwise noted.

Table 8.

Parameter	Rating
AV <sub>DD</sub> to IOV <sub>DD</sub>	−0.3 V to +0.3 V
AGND to DGND	−0.3 V to +0.3 V
IOV <sub>DD</sub> to IOGND, AV <sub>DD</sub> to AGND	−0.3 V to +6 V
Digital Input Voltage to IOGND	−0.3 V to +5.3 V
Digital Output Voltage to IOGND	−0.3 V to IOV <sub>DD</sub> + 0.3 V
V <sub>REF</sub> to AGND	−0.3 V to AV <sub>DD</sub> + 0.3 V
Analog Inputs to AGND	−0.3 V to AV <sub>DD</sub> + 0.3 V
Analog Outputs to AGND	−0.3 V to AV <sub>DD</sub> + 0.3 V
Operating Temperature Range, Industrial	−40°C to +125°C
Storage Temperature Range	−65°C to +150°C
Junction Temperature	150°C
θ <sub>JA</sub> Thermal Impedance	
64-Lead LFCSP	24°C/W
80-Lead LQFP	38°C/W
Peak Solder Reflow Temperature	
SnPb Assemblies (10 sec to 30 sec)	240°C
RoHS Compliant Assemblies (20 sec to 40 sec)	260°C

Stresses above those listed under Absolute Maximum Ratings may cause permanent damage to the device. This is a stress rating only; functional operation of the device at these or any other conditions above those indicated in the operational section of this specification is not implied. Exposure to absolute maximum rating conditions for extended periods may affect device reliability.

Only one absolute maximum rating can be applied at any one time.

### ESD CAUTION



**ESD (electrostatic discharge) sensitive device.** Charged devices and circuit boards can discharge without detection. Although this product features patented or proprietary protection circuitry, damage may occur on devices subjected to high energy ESD. Therefore, proper ESD precautions should be taken to avoid performance degradation or loss of functionality.

# PIN CONFIGURATIONS AND FUNCTION DESCRIPTIONS

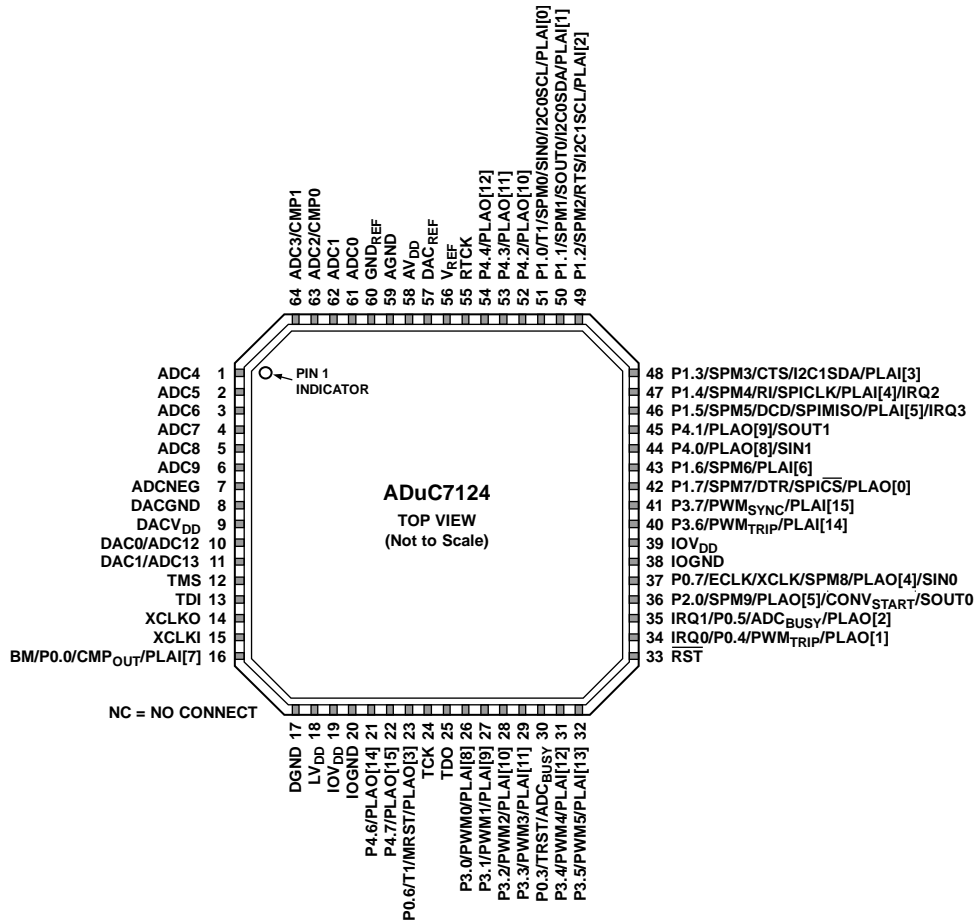

- NOTES**
1. THE EXPOSED PADDLE MUST BE SOLDERED TO THE PCB TO ENSURE PROPER HEAT DISSIPATION, NOISE, AND MECHANICAL STRENGTH BENEFITS.

Figure 7. ADuC7124 Pin Configuration

09123-107

Table 9. Pin Function Descriptions (ADuC7124 64-Lead LFCSP)

Pin No.	Mnemonic	Description
0	Exposed Paddle	Exposed Paddle. The LFCSP_VQ has an exposed paddle that must be left unconnected.
1	ADC4	Single-Ended or Differential Analog Input 4.
2	ADC5	Single-Ended or Differential Analog Input 5.
3	ADC6	Single-Ended or Differential Analog Input 6.
4	ADC7	Single-Ended or Differential Analog Input 7.
5	ADC8	Single-Ended or Differential Analog Input 8.
6	ADC9	Single-Ended or Differential Analog Input 9.
7	ADCNEG	Bias Point or Negative Analog Input of the ADC in Pseudo Differential Mode. Must be connected to the ground of the signal to convert. This bias point must be between 0V and 1V.
8	DACGND	Ground for the DAC. Typically connected to AGND.
9	DACV <sub>DD</sub>	3.3V Power Supply for the DACs. Must be connected to AV <sub>DD</sub> .
10	DAC0/ADC12	DAC0 Voltage Output (DAC0). Single-Ended or Differential Analog Input 12 (ADC12).
11	DAC1/ADC13	DAC1 Voltage Output (DAC1). Single-Ended or Differential Analog Input 13 (ADC13).
12	TMS	JTAG Test Port Input, Test Mode Select. Debug and download access.
13	TDI	JTAG Test Port Input, Test Data In.

Pin No.	Mnemonic	Description
14	XCLKO	Output from the Crystal Oscillator Inverter.
15	XCLKI	Input to the Crystal Oscillator Inverter and Input to the Internal Clock Generator Circuits.
16	BM/P0.0/CMP <sub>OUT</sub> /PLAI[7]	Multifunction I/O Pin. Boot mode (BM). The ADuC7124 enters download mode if BM is low at reset and executes code if BM is pulled high at reset through a 1 kΩ resistor. General-Purpose Input and Output Port 0.0 (P0.0). Voltage Comparator Output (CMP <sub>OUT</sub> ) Programmable Logic Array Input Element 7 (PLAI[7]).
17	DGND	Ground for Core Logic.
18	LV <sub>DD</sub>	2.6 V Output of the On-Chip Voltage Regulator. This output must be connected to a 0.47 μF capacitor to DGND only.
19	IOV <sub>DD</sub>	3.3 V Supply for GPIO and Input of the On-Chip Voltage Regulator.
20	IOGND	Ground for GPIO. Typically connected to DGND.
21	P4.6/PLAO[14]	General-Purpose Input and Output Port 4.6 (P4.6). Programmable Logic Array Output Element 14 (PLAO[14]).
22	P4.7/PLAO[15]	General-Purpose Input and Output Port 4.7 (P4.7). Programmable Logic Array Output Element 15 (PLAO[15]).
23	P0.6/T1/MRST/PLAO[3]	Multifunction Pin, Driven Low After Reset. General-Purpose Output Port 0.6 (P0.6). Timer1 Input (T1). Power-On Reset Output (MRST). Programmable Logic Array Output Element 3 (PLAO[3]).
24	TCK	JTAG Test Port Input, Test Clock. Debug and download access.
25	TDO	JTAG Test Port Output, Test Data Out.
26	P3.0/PWM0/PLAI[8]	General-Purpose Input and Output Port 3.0 (P3.0). PWM Phase 0 (PWM0). Programmable Logic Array Input Element 8 (PLAI[8]).
27	P3.1/PWM1/PLAI[9]	General-Purpose Input and Output Port 3.1 (P3.1). PWM Phase 1 (PWM1). Programmable Logic Array Input Element 9 (PLAI[9]).
28	P3.2/PWM2/PLAI[10]	General-Purpose Input and Output Port 3.2 (P3.2). PWM Phase 2 (PWM2). Programmable Logic Array Input Element 10 (PLAI[10]).
29	P3.3/PWM3/PLAI[11]	General-Purpose Input and Output Port 3.3 (P3.3). PWM Phase 3 (PWM3). Programmable Logic Array Input Element 11 (PLAI[11]).
30	P0.3/TRST/ADC <sub>BUSY</sub>	General-Purpose Input and Output Port 0.3 (P0.3). JTAG Test Port Input, Test Reset (TRST). JTAG reset input. Debug and download access. If this pin is held low, JTAG access is not possible because the JTAG interface is held in reset and P0.1/P0.2/P0.3 are configured as GPIO pins. ADC <sub>BUSY</sub> Signal Output (ADC <sub>BUSY</sub> ).
31	P3.4/PWM4/PLAI[12]	General-Purpose Input and Output Port 3.4 (P3.4). PWM Phase 4 (PWM4). Programmable Logic Array Input 12 (PLAI[12]).
32	P3.5/PWM5/PLAI[13]	General-Purpose Input and Output Port 3.5 (P3.5). PWM Phase 5 (PWM5). Programmable Logic Array Input Element 13 (PLAI[13]).
33	$\overline{\text{RST}}$	Reset Input, Active Low.
34	IRQ0/P0.4/PWM <sub>TRIP</sub> /PLAO[1]	Multifunction I/O Pin. External Interrupt Request 0, Active High (IRQ0). General-Purpose Input and Output Port 0.4 (P0.4). PWM Trip External Input (PWM <sub>TRIP</sub> ). Programmable Logic Array Output Element 1 (PLAO[1]).

Pin No.	Mnemonic	Description
35	IRQ1/P0.5/ADC <sub>BUSY</sub> /PLAO[2]	Multifunction I/O Pin. External Interrupt Request 1, Active High (IRQ1). General-Purpose Input and Output Port 0.5 (P0.5). ADC <sub>BUSY</sub> Signal Output (ADC <sub>BUSY</sub> ). Programmable Logic Array Output Element 2 (PLAO[2]).
36	P2.0/SPM9/PLAO[5]/CONV <sub>START</sub> /SOUT0	General-Purpose Input and Output Port 2.0 (P2.0). Serial Port Multiplexed (SPM9). Programmable Logic Array Output Element 5 (PLAO[5]). Start Conversion Input Signal for ADC (CONV <sub>START</sub> ). UART0 Output (SOUT0).
37	P0.7/ECLK/XCLK/SPM8/PLAO[4]/SIN0	General-Purpose Input and Output Port 0.7 (P0.7). Output for External Clock Signal (ECLK). Input to the Internal Clock Generator Circuits (XCLK). Serial Port Multiplexed (SPM8). Programmable Logic Array Output Element 4 (PLAO[4]). UART0 Input (SIN0).
38	IOGND	Ground for GPIO. Typically connected to DGND.
39	IOV <sub>DD</sub>	3.3 V Supply for GPIO and Input of the On-Chip Voltage Regulator.
40	P3.6/PWM <sub>TRIP</sub> /PLAI[14]	General-Purpose Input and Output Port 3.6 (P3.6). PWM Safety Cutoff (PWM <sub>TRIP</sub> ). Programmable Logic Array Input Element 14 (PLAI[14]).
41	P3.7/PWM <sub>SYNC</sub> /PLAI[15]	General-Purpose Input and Output Port 3.7 (P3.7). PWM Synchronization Input/Output (PWM <sub>SYNC</sub> ). Programmable Logic Array Input Element 15 (PLAI[15]).
42	P1.7/SPM7/DTR/SPIC $\overline{S}$ /PLAO[0]	General-Purpose Input and Output Port 1.7 (P1.7). Serial Port Multiplexed. UART, SPI (SPM7). Data Terminal Ready (DTR). Chip Select (SPIC $\overline{S}$ ). Programmable Logic Array Output Element 0 (PLAO[0]).
43	P1.6/SPM6/PLAI[6]	General-Purpose Input and Output Port 1.6 (P1.6). Serial Port Multiplexed (SPM6). Programmable Logic Array Input Element 6 (PLAI[6]).
44	P4.0/PLAO[8]/SIN1	General-Purpose Input and Output Port 4.0 (P4.0). Programmable Logic Array Output Element 8 (PLAO[8]). UART1 Input (SIN1).
45	P4.1/PLAO[9]/SOUT1	General-Purpose Input and Output Port 4.1 (P4.1). Programmable Logic Array Output Element 9 (PLAO[9]). UART1 Output (SOUT1).
46	P1.5/SPM5/DCD/SPIMISO/PLAI[5]/IRQ3	General-Purpose Input and Output Port 1.5 (P1.5). Serial Port Multiplexed. UART, SPI (SPM5). Data Carrier Detect (DCD). Master Input, Slave Output (SPI MISO). Programmable Logic Array Input Element 5 (PLAI[5]). External Interrupt Request 3, Active High (IRQ3).
47	P1.4/SPM4/RI/SPICLK/PLAI[4]/IRQ2	General-Purpose Input and Output Port 1.4 (P1.4). Serial Port Multiplexed. UART, SPI (SPM4). Ring Indicator (RI). Serial Clock Input/Output (SPI SCLK). Programmable Logic Array Input Element 4 (PLAI[4]). External Interrupt Request 2, Active High (IRQ2).
48	P1.3/SPM3/CTS/I2C1SDA/PLAI[3]	General-Purpose Input and Output Port 1.3 (P1.3). Serial Port Multiplexed. UART, I2C1 (SPM3). Clear to Send (CTS). I2C1 (I2C1SDA). Programmable Logic Array Input Element 3 (PLAI[3]).
49	P1.2/SPM2/RTS/I2C1SCL/PLAI[2]	General-Purpose Input and Output Port 1.2 (P1.2). Serial Port Multiplexed (SPM2). Ready to Send (RTS). I2C1 (I2C1SCL). Programmable Logic Array Input Element 2 (PLAI[2]).

Pin No.	Mnemonic	Description
50	P1.1/SPM1/SOUT0/I2C0SDA/PLAI[1]	General-Purpose Input and Output Port 1.1 (P1.1). Serial Port Multiplexed (SPM1). UART download pin, UART0 Output (SOUT0). I2C0 (I2C0SDA). Programmable Logic Array Input Element 1 (PLAI[1]).
51	P1.0/T1/SPM0/SIN0/I2C0SCL/PLAI[0]	General-Purpose Input and Output Port 1.0 (P1.0). Timer1 Input (T1). Serial Port Multiplexed (SPM0). UART download pin, UART0 Input (SIN0). I2C0 (I2C0SCL). Programmable Logic Array Input Element 0 (PLAI[0]).
52	P4.2/PLAO[10]	General-Purpose Input and Output Port 4.2 (P4.2). Programmable Logic Array Output Element 10 (PLAO[10]).
53	P4.3/PLAO[11]	General-Purpose Input and Output Port 4.3 (P4.3). Programmable Logic Array Output Element 11 (PLAO[11]).
54	P4.4/PLAO[12]	General-Purpose Input and Output Port 4.4 (P4.4). Programmable Logic Array Output Element 12 (PLAO[12]).
55	RTCK	JTAG Test Port Output, JTAG Return Test Clock.
56	V <sub>REF</sub>	2.5 V Internal Voltage Reference. Must be connected to a 0.47 $\mu$ F capacitor when using the internal reference.
57	DAC <sub>REF</sub>	External Voltage Reference for the DACs. Range: DACGND to DACV <sub>DD</sub> .
58	AV <sub>DD</sub>	3.3 V Analog Power.
59	AGND	Analog Ground. Ground reference point for the analog circuitry.
60	GND <sub>REF</sub>	Ground Voltage Reference for the ADC. For optimal performance, the analog power supply should be separated from IOGND and DGND.
61	ADC0	Single-Ended or Differential Analog Input 0.
62	ADC1	Single-Ended or Differential Analog Input 1.
63	ADC2/CMP0	Single-Ended or Differential Analog Input 2 (ADC2). Comparator Positive Input (CMP0).
64	ADC3/CMP1	Single-Ended or Differential Analog Input 3 (ADC3). Comparator Negative Input (CMP1).

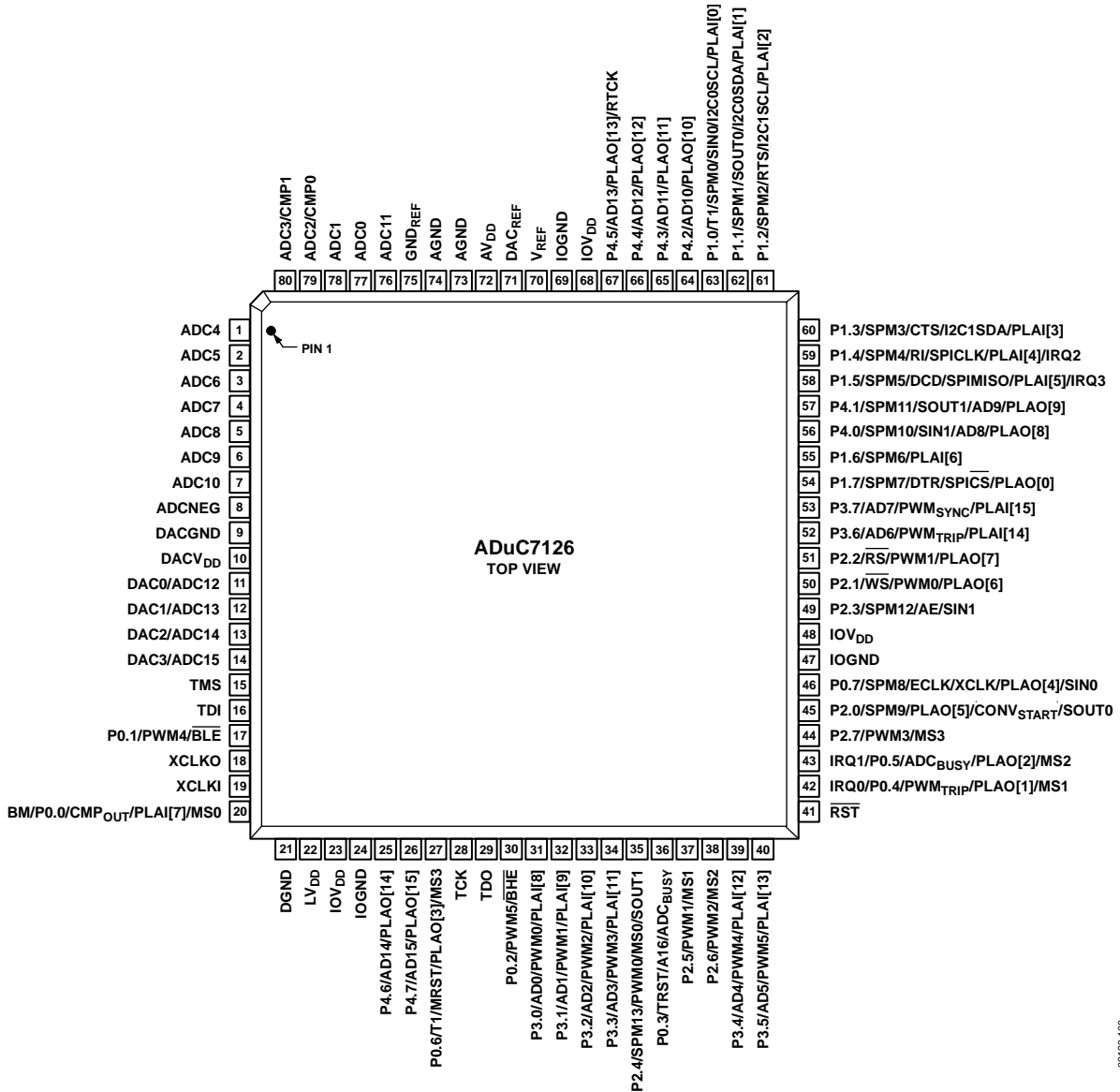

Figure 8. ADuC7126 Pin Configuration

09123-108

Table 10. Pin Function Descriptions (ADuC7126 80-Lead LQFP)

Pin No.	Mnemonic	Description
1	ADC4	Single-Ended or Differential Analog Input 4.
2	ADC5	Single-Ended or Differential Analog Input 5.
3	ADC6	Single-Ended or Differential Analog Input 6.
4	ADC7	Single-Ended or Differential Analog Input 7.
5	ADC8	Single-Ended or Differential Analog Input 8.
6	ADC9	Single-Ended or Differential Analog Input 9.
7	ADC10	Single-Ended or Differential Analog Input 10.
8	ADCNEG	Bias Point or Negative Analog Input of the ADC in Pseudo Differential Mode. Must be connected to the ground of the signal to convert. This bias point must be between 0 V and 1 V.
9	DACGND	Ground for the DAC. Typically connected to AGND.
10	DACV <sub>DD</sub>	3.3 V Power Supply for the DACs. Must be connected to AV <sub>DD</sub> .

Pin No.	Mnemonic	Description
11	DAC0/ADC12	DAC0 Voltage Output (DAC0). Single-Ended or Differential Analog Input 12 (ADC12).
12	DAC1/ADC13	DAC1 Voltage Output (DAC1). Single-Ended or Differential Analog Input 13 (ADC13).
13	DAC2/ADC14	DAC2 Voltage Output (DAC2). Single-Ended or Differential Analog Input 14 (ADC14).
14	DAC3/ADC15	DAC3 Voltage Output (DAC3). Single-Ended or Differential Analog Input 15 (ADC15).
15	TMS	JTAG Test Port Input, Test Mode Select. Debug and download access.
16	TDI	JTAG Test Port Input, Test Data In. Debug and download access.
17	P0.1/PWM4/ $\overline{\text{BLE}}$	General-Purpose Input and Output Port 0.1 (P0.1). PWM Phase 4 (PWM4). External Memory Byte Low Enable ( $\overline{\text{BLE}}$ ). This pin does not work as GPIO on I <sup>2</sup> C versions of the chip.
18	XCLKO	Output from the Crystal Oscillator Inverter.
19	XCLKI	Input to the Crystal Oscillator Inverter and Input to the Internal Clock Generator Circuits.
20	BM/P0.0/CMP <sub>OUT</sub> /PLAI[7]/MS0	Multifunction I/O Pin. Boot Mode Entry Pin (BM). The ADuC7126 enters UART download mode if BM is low at reset and executes code if BM is pulled high at reset through a 1 k $\Omega$ resistor. The ADuC7126 enters I <sup>2</sup> C download mode in I <sup>2</sup> C version parts if BM is low at reset with a flash address of 0x800014 = 0xFFFFFFFF. The ADuC7126 executes code if BM is pulled high at reset or if BM is low at reset with a flash address 0x800014 $\neq$ 0xFFFFFFFF. General-Purpose Input and Output Port 0.0 (P0.0). Voltage Comparator Output/Programmable Logic Array Input Element 7 (CMP <sub>OUT</sub> ). External Memory Select 0 (MS0). By default, this pin is configured as GPIO.
21	DGND	Ground for Core Logic.
22	LV <sub>DD</sub>	2.6 V Output of the On-Chip Voltage Regulator. This output must be connected to a 0.47 $\mu$ F capacitor to DGND only.
23	IOV <sub>DD</sub>	3.3 V Supply for GPIO and Input of the On-Chip Voltage Regulator.
24	IOGND	Ground for GPIO. Typically connected to DGND.
25	P4.6/AD14/PLAO[14]	General-Purpose Input and Output Port 4.6 (P4.6). External Memory Interface (AD14). Programmable Logic Array Output Element 14 (PLAO[14]).
26	P4.7/AD15/PLAO[15]	General-Purpose Input and Output Port 4.7 (P4.7). External Memory Interface (AD15). Programmable Logic Array Output Element 15 (PLAO[15]).
27	P0.6/T1/MRST/PLAO[3]/MS3	Multifunction Pin, Driven Low After Reset. General-Purpose Output Port 0.6 (P0.6). Timer1 Input (T1). Power-On Reset Output (MRST). Programmable Logic Array Output Element 3 (PLAO[3]). External Memory Select 3 (MS3).
28	TCK	JTAG Test Port Input, Test Clock. Debug and download access.
29	TDO	JTAG Test Port Output, Test Data Out. Debug and download access.
30	P0.2/PWM5/ $\overline{\text{BHE}}$	General-Purpose Input and Output Port 0.2 (P0.2). PWM Phase 5 (PWM5). External Memory Byte High Enable ( $\overline{\text{BHE}}$ ). This pin does not work as GPIO on I <sup>2</sup> C versions of the chip.
31	P3.0/AD0/PWM0/PLAI[8]	General-Purpose Input and Output Port 3.0 (P3.0). External Memory Interface (AD0). PWM Phase 0 (PWM0). Programmable Logic Array Input Element 8 (PLAI[8]).
32	P3.1/AD1/PWM1/PLAI[9]	General-Purpose Input and Output Port 3.1 (P3.1). External Memory Interface (AD1). PWM Phase 1 (PWM1). Programmable Logic Array Input Element 9 (PLAI[9]).

Pin No.	Mnemonic	Description
33	P3.2/AD2/PWM2/PLAI[10]	General-Purpose Input and Output Port 3.2 (P3.2). External Memory Interface (AD2). PWM Phase 2 (PWM2). Programmable Logic Array Input Element 10 (PLAI[10]).
34	P3.3/AD3/PWM3/PLAI[11]	General-Purpose Input and Output Port 3.3 (P3.3). External Memory Interface (AD3). PWM Phase 3 (PWM3). Programmable Logic Array Input Element 11 (PLAI[11]).
35	P2.4/SPM13/PWM0/MS0/SOUT1	General-Purpose Input and Output Port 2.4 (P2.4). Serial Port Multiplexed (SPM13) PWM Phase 0 (PWM0). External Memory Select 0 (MS0). UART1 Output (SOUT1).
36	P0.3/TRST/A16/ADC <sub>BUSY</sub>	General-Purpose Input and Output Port 0.3 (P0.3). JTAG Test Port Input, Test Reset (TRST).JTAG Reset Input. Debug and download access. If this pin is held low, JTAG access is not possible because the JTAG interface is held in reset and P0.1/P0.2/P0.3 are configured as GPIO pins. Address Line (A16). ADC <sub>BUSY</sub> Signal Output (ADC <sub>BUSY</sub> ).
37	P2.5/PWM1/MS1	General-Purpose Input and Output Port 2.5 (P2.5). PWM Phase 1 (PWM1). External Memory Select 1 (MS1).
38	P2.6/PWM2/MS2	General-Purpose Input and Output Port 2.6 (P2.6). PWM Phase 2 (PWM2). External Memory Select 2 (MS2).
39	P3.4/AD4/PWM4/PLAI[12]	General-Purpose Input and Output Port 3.4 (P3.4). External Memory Interface (AD4). PWM Phase 4 (PWM4). Programmable Logic Array Input 12 (PLAI[12]).
40	P3.5/AD5/PWM5/PLAI[13]	General-Purpose Input and Output Port 3.5 (P3.5). External Memory Interface (AD5). PWM Phase 5 (PWM5). Programmable Logic Array Input Element 13 (PLAI[13]).
41	$\overline{RST}$	Reset Input, Active Low.
42	IRQ0/P0.4/PWM <sub>TRIP</sub> /PLAO[1]/MS1	Multifunction I/O Pin. External Interrupt Request 0, Active High (IRQ0). General-Purpose Input and Output Port 0.4 (P0.4). PWM Trip External Input (PWM <sub>TRIP</sub> ). Programmable Logic Array Output Element 1 (PLAO[1]). External Memory Select 1 (MS1)..
43	IRQ1/P0.5/ADC <sub>BUSY</sub> /PLAO[2]/MS2	Multifunction I/O Pin. External Interrupt Request 1, Active High (IRQ1). General-Purpose Input and Output Port 0.5 (P0.5). ADC <sub>BUSY</sub> Signal Output (ADC <sub>BUSY</sub> ). Programmable Logic Array Output Element 2 (PLAO[2]). External Memory Select 2 (MS2).
44	P2.7/PWM3/MS3	General-Purpose Input and Output Port 2.7 (P2.7). PWM Phase 3 (PWM3). External Memory Select 3 (MS3).
45	P2.0/SPM9/PLAO[5]/CONV <sub>START</sub> /SOUT0	General-Purpose Input and Output Port 2.0 (P2.0). Serial Port Multiplexed (SPM9). Programmable Logic Array Output Element 5 (PLAO[5]). Start Conversion Input Signal for ADC (CONV <sub>START</sub> ). UART0 Output (SOUT0).
46	P0.7/SPM8/ECLK/XCLK/PLAO[4]/SIN0	General-Purpose Input and Output Port 0.7 (P0.7). Serial Port Multiplexed (SPM8). Output for External Clock Signal (ECLK). Input to the Internal Clock Generator Circuits (XCLK). Programmable Logic Array Output Element 4 (PLAO[4]). UART0 Input (SIN0).
47	IOGND	Ground for GPIO. Typically connected to DGND.

Pin No.	Mnemonic	Description
48	IOV <sub>DD</sub>	3.3 V Supply for GPIO and Input of the On-Chip Voltage Regulator.
49	P2.3/SPM12/AE/SIN1	General-Purpose Input and Output Port 2.3 (P2.3). Serial Port Multiplexed (SPM12). External Memory Access Enable (AE). UART1 Input (SIN1).
50	P2.1/ $\overline{WS}$ /PWM0/PLAO[6]	General-Purpose Input and Output Port 2.1 (P2.1). External Memory Write Strobe ( $\overline{WS}$ ). PWM Phase 0 (PWM0). Programmable Logic Array Output Element 6 (PLAO[6]).
51	P2.2/ $\overline{RS}$ /PWM1/PLAO[7]	General-Purpose Input and Output Port 2.2 (P2.2). External Memory Read Strobe ( $\overline{RS}$ ). PWM Phase 1 (PWM1). Programmable Logic Array Output Element 7 (PLAO[7]).
52	P3.6/AD6/PWM <sub>TRIP</sub> /PLAI[14]	General-Purpose Input and Output Port 3.6 (P3.6). External Memory Interface (AD6). PWM Safety Cutoff (PWM <sub>TRIP</sub> ). Programmable Logic Array Input Element 14 (PLAI[14]).
53	P3.7/AD7/PWM <sub>SYNC</sub> /PLAI[15]	General-Purpose Input and Output Port 3.7 (P3.7). External Memory Interface (AD7). PWM Synchronization (PWM <sub>SYNC</sub> ). Programmable Logic Array Input Element 15 (PLAI[15]).
54	P1.7/SPM7/DTR/ $\overline{SPIC\overline{S}}$ /PLAO[0]	General-Purpose Input and Output Port 1.7 (P1.7). Serial Port Multiplexed (SPM7). Data Terminal Ready (DTR). Chip Select ( $\overline{SPIC\overline{S}}$ ). Programmable Logic Array Output Element 0 (PLAO[0]).
55	P1.6/SPM6/PLAI[6]	General-Purpose Input and Output Port 1.6 (P1.6). Serial Port Multiplexed (SPM6). Programmable Logic Array Input Element 6 (PLAI[6]).
56	P4.0/SPM10/SIN1/AD8/PLAO[8]	General-Purpose Input and Output Port 4.0 (P4.0). Serial Port Multiplexed (SPM10). UART1 Input (SIN1). External Memory Interface (AD8). Programmable Logic Array Output Element 8 (PLAO[8]).
57	P4.1/SPM11/SOUT1/AD9/PLAO[9]	General-Purpose Input and Output Port 4.1 (P4.1). Serial Port Multiplexed (SPM11). UART1 Output (SOUT1). External Memory Interface (AD9). Programmable Logic Array Output Element 9 (PLAO[9]).
58	P1.5/SPM5/DCD/SPIMISO/PLAI[5]/IRQ3	General-Purpose Input and Output Port 1.5 (P1.5). Serial Port Multiplexed (SPM5). Data Carrier Detect (DCD). Master Input, Slave Output (SPI MISO). Programmable Logic Array Input Element 5 (PLAI[5]). External Interrupt Request 3, Active High (IRQ3).
59	P1.4/SPM4/RI/SPICLK/PLAI[4]/IRQ2	General-Purpose Input and Output Port 1.4 (P1.4). Serial Port Multiplexed (SPM4). Ring Indicator (RI). Serial Clock Input/Output (SPI SCLK). Programmable Logic Array Input Element 4 (PLAI[4]). External Interrupt Request 2, Active High (IRQ2).
60	P1.3/SPM3/CTS/I2C1SDA/PLAI[3]	General-Purpose Input and Output Port 1.3 (P1.3). Serial Port Multiplexed (SPM3). Clear to Send (CTS). I2C1 (I2C1SDA). Programmable Logic Array Input Element 3 (PLAI[3]).
61	P1.2/SPM2/RTS/I2C1SCL/PLAI[2]	General-Purpose Input and Output Port 1.2 (P1.2). Serial Port Multiplexed (SPM2). Ready to Send (RTS). I2C1 (I2C1SCL). Programmable Logic Array Input Element 2 (PLAI[2]).

Pin No.	Mnemonic	Description
62	P1.1/SPM1/SOUT0/I2C0SDA/PLAI[1]	General-Purpose Input and Output Port 1.1 (P1.1). Serial Port Multiplexed (SPM1). UART0 Output (SOUT0). I2C0 (I2C0SDA). Programmable Logic Array Input Element 1 (PLAI[1]).
63	P1.0/T1/SPM0/SIN0/I2C0SCL/PLAI[0]	General-Purpose Input and Output Port 1.0 (P1.0). Timer1 Input (T1). Serial Port Multiplexed (SPM0). UART0 Input (SIN0). I2C0 (I2C0SCL). Programmable Logic Array Input Element 0 (PLAI[0]).
64	P4.2/AD10/PLAO[10]	General-Purpose Input and Output Port 4.2 (P4.2). External Memory Interface (AD10). Programmable Logic Array Output Element 10 (PLAO[10]).
65	P4.3/AD11/PLAO[11]	General-Purpose Input and Output Port 4.3 (P4.3). External Memory Interface (AD11). Programmable Logic Array Output Element 11 (PLAO[11]).
66	P4.4/AD12/PLAO[12]	General-Purpose Input and Output Port 4.4 (P4.4). External Memory Interface (AD12). Programmable Logic Array Output Element 12 (PLAO[12]).
67	P4.5/AD13/PLAO[13]/RTCK	General-Purpose Input and Output Port 4.5 (P4.5). External Memory Interface (AD13). Programmable Logic Array Output Element 13 (PLAO[13]). JTAG Return Test Clock (RTCK).
68	IOV <sub>DD</sub>	3.3 V Supply for GPIO and Input of the On-Chip Voltage Regulator.
69	IOGND	Ground for GPIO. Typically connected to DGND.
70	V <sub>REF</sub>	2.5 V Internal Voltage Reference. Must be connected to a 0.47 $\mu$ F capacitor when using the internal reference.
71	DAC <sub>REF</sub>	External Voltage Reference for the DACs. Range: DACGND to DACV <sub>DD</sub> .
72	AV <sub>DD</sub>	3.3 V Analog Power.
73, 74	AGND	Analog Ground. Ground reference point for the analog circuitry.
75	GND <sub>REF</sub>	Ground Voltage Reference for the ADC. For optimal performance, the analog power supply should be separated from IOGND and DGND.
76	ADC11	Single-Ended or Differential Analog Input 11.
77	ADC0	Single-Ended or Differential Analog Input 0.
78	ADC1	Single-Ended or Differential Analog Input 1.
79	ADC2/CMP0	Single-Ended or Differential Analog Input 2 (ADC2). Comparator Positive Input (CMP0).
80	ADC3/CMP1	Single-Ended or Differential Analog Input 3 (ADC3). Comparator Negative Input (CMP1).

TYPICAL PERFORMANCE CHARACTERISTICS

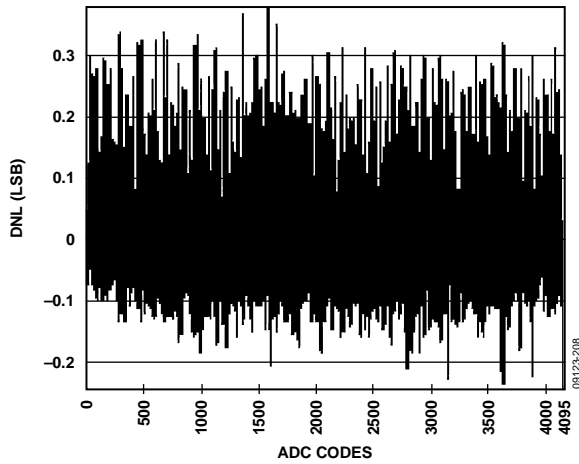

Figure 9. Typical DNL Error,  
 Temperature 25°C,  $V_{REF}$  = Internal 2.5 V, Single-Ended Mode  
 ADCCP = ADC0, ADCCN = ADC0, Sampling Rate = 345 kHz  
 Worst Case Positive = 0.38 LSB, Code 1567  
 Worst Case Negative = -0.24 LSB, Code 4094

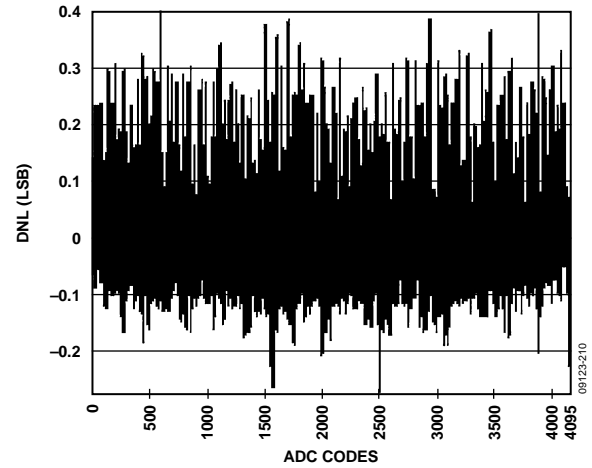

Figure 11. Typical DNL Error,  
 Temperature 25°C,  $V_{REF}$  = Internal 2.5 V, Single-Ended Mode  
 ADCCP = DAC1/ADC13, ADCCN = ADC0, Sampling Rate = 345 kHz  
 Worst Case Positive = 0.40 LSB, Code 607  
 Worst Case Negative = -0.27 LSB, Code 2486

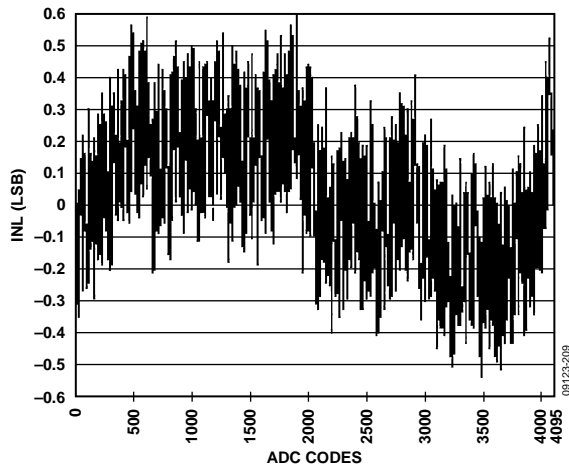

Figure 10. Typical INL Error,  
 Temperature 25°C,  $V_{REF}$  = Internal 2.5 V, Single-Ended Mode  
 ADCCP = ADC0, ADCCN = ADC0, Sampling Rate = 345 kHz  
 Worst Case Positive = 0.60 LSB, Code 1890  
 Worst Case Negative = -0.54 LSB, Code 3485

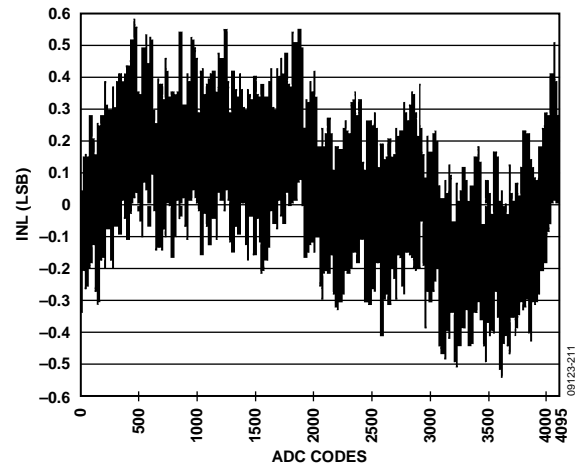

Figure 12. Typical INL Error,  
 Temperature 25°C,  $V_{REF}$  = Internal 2.5 V, Single-Ended Mode  
 ADCCP = DAC1/ADC13, ADCCN = ADC0, Sampling Rate = 345 kHz  
 Worst Case Positive = 0.58 LSB, Code 480  
 Worst Case Negative = -0.54 LSB, Code 3614

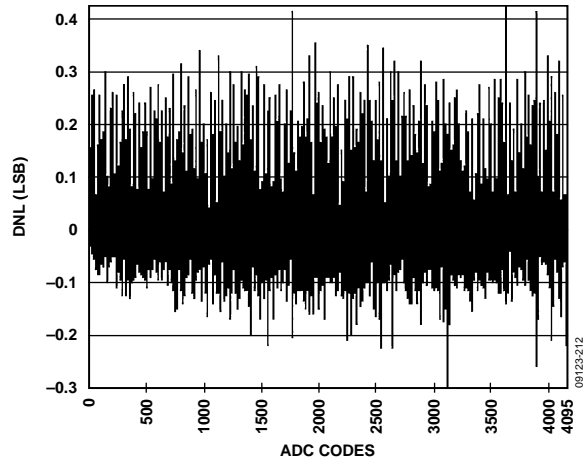

Figure 13. Typical DNL Error,  
 Temperature 25°C,  $V_{REF}$  = Internal 2.5 V, Single-Ended Mode  
 ADCCP = ADC8, ADCCN = ADC0, Sampling Rate = 345 kHz  
 Worst-Case Positive = 0.42 LSB, Code 3583  
 Worst-Case Negative = -0.32 LSB, Code 3073

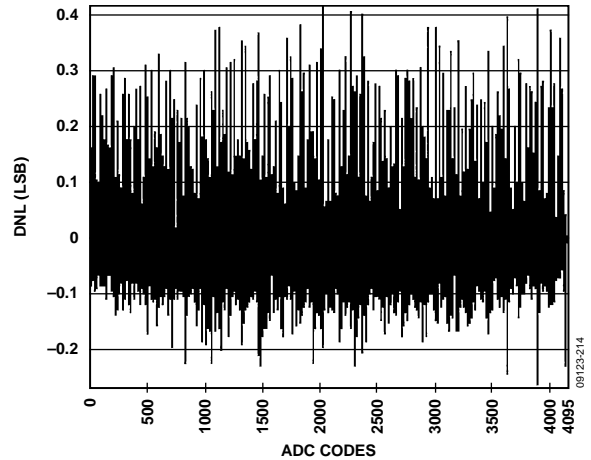

Figure 15. Typical DNL Error,  
 Temperature 25°C,  $V_{REF}$  = Internal 2.5 V, Single-Ended Mode  
 ADCCP = DAC3/ADC15, ADCCN = ADC0, Sampling Rate = 345 kHz  
 Worst-Case Positive = 0.41 LSB, Code 2016  
 Worst-Case Negative = -0.26 LSB, Code 3841

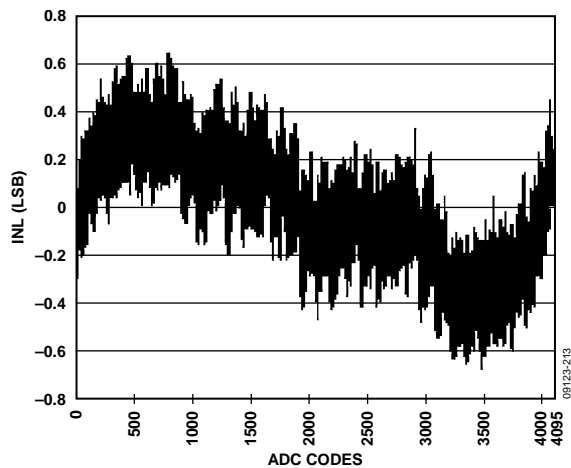

Figure 14. Typical INL Error,  
 Temperature 25°C,  $V_{REF}$  = Internal 2.5 V, Single-Ended Mode  
 ADCCP = ADC8, ADCCN = ADC0, Sampling Rate = 345 kHz  
 Worst-Case Positive = 0.64 LSB, Code 802  
 Worst-Case Negative = -0.69 LSB, Code 3485

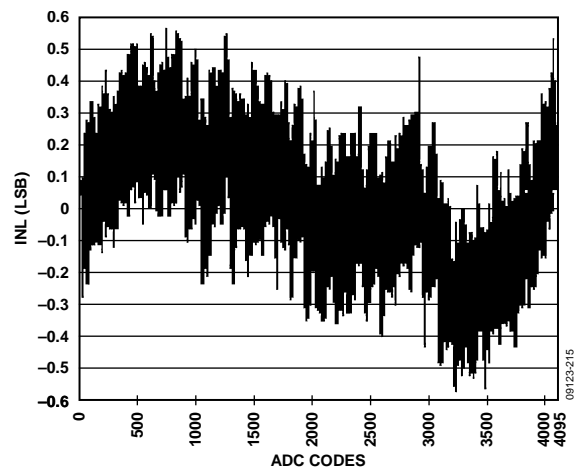

Figure 16. Typical INL Error,  
 Temperature 25°C,  $V_{REF}$  = Internal 2.5 V, Single-Ended Mode  
 ADCCP = DAC3/ADC15, ADCCN = ADC0, Sampling Rate = 345 kHz  
 Worst-Case Positive = 0.55 LSB, Code 738  
 Worst-Case Negative = -0.68 LSB, Code 3230

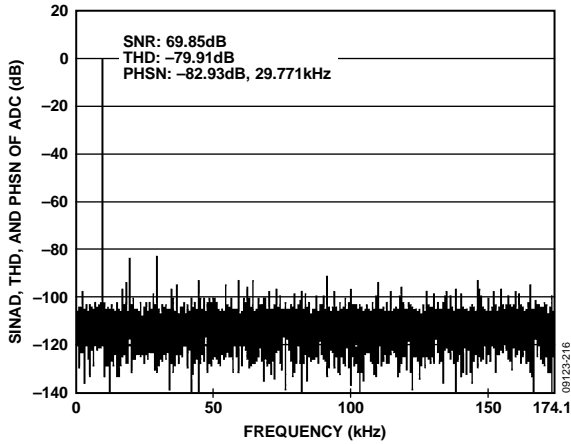

Figure 17. SINAD, THD, and PHSN of ADC,  $V_{REF}$  = Internal 2.5 V, Single-Ended Mode  
ADCCP = ADC0

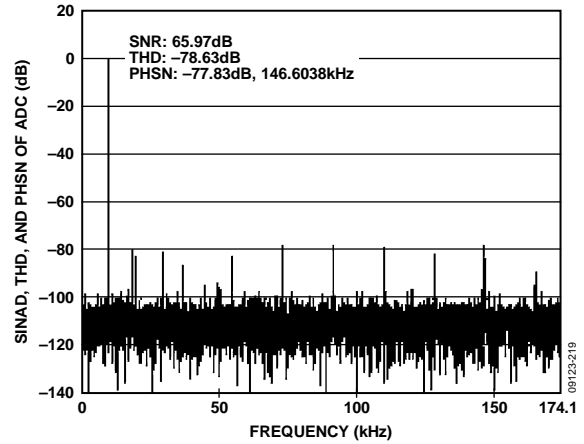

Figure 20. SINAD, THD, and PHSN of ADC,  $V_{REF}$  = Internal 2.5 V, Single-Ended Mode  
ADCCP = ADC15/DAC3, ADCCN = ADC0

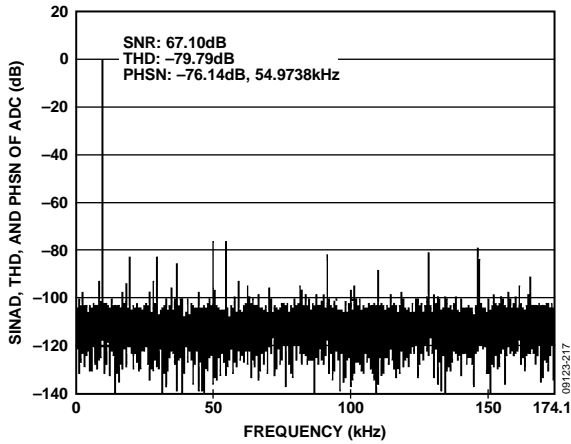

Figure 18. SINAD, THD, and PHSN of ADC,  $V_{REF}$  = Internal 2.5 V, Single-Ended Mode  
ADCCP = DAC1/ADC13, ADCCN = ADC0

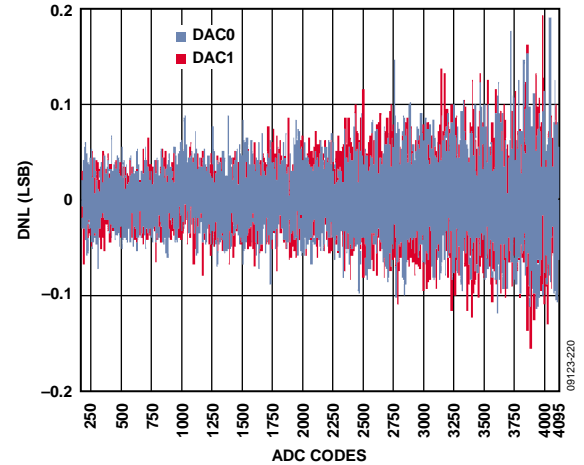

Figure 21. DAC DNL Error,  
DAC0 Max Positive DNL: 0.188951, DAC1 Max Positive DNL: 0.190343  
DAC0 Max Negative DNL: -0.120081, DAC1 Max Negative DNL: -0.15697

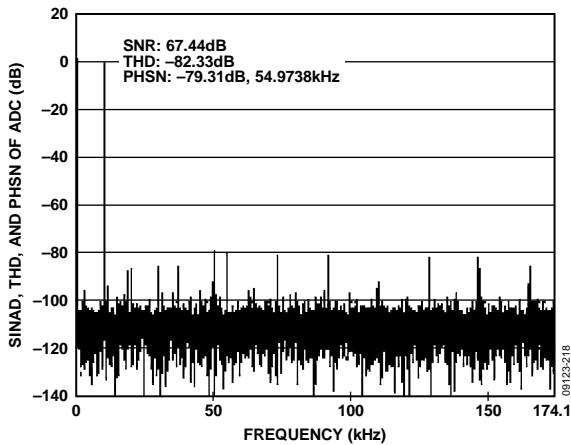

Figure 19. SINAD, THD, and PHSN of ADC,  $V_{REF}$  = Internal 2.5 V, Single-Ended Mode  
ADCCP = ADC8, ADCCN = ADC0

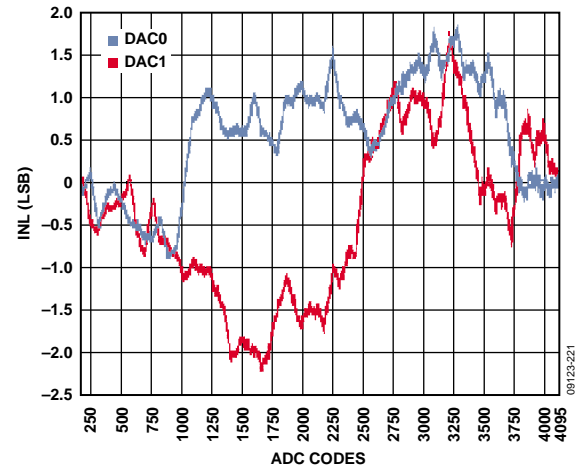

Figure 22. DAC INL Error,  
DAC0 Max Positive INL: 1.84106, DAC1 Max Positive INL: 1.75312  
DAC0 Max Negative INL: -0.887319, DAC1 Max Negative INL: -2.23708

## TERMINOLOGY

### ADC SPECIFICATIONS

#### Integral Nonlinearity (INL)

The maximum deviation of any code from a straight line passing through the endpoints of the ADC transfer function. The endpoints of the transfer function are zero scale, a point  $\frac{1}{2}$  LSB below the first code transition, and full scale, a point  $\frac{1}{2}$  LSB above the last code transition.

#### Differential Nonlinearity (DNL)

The difference between the measured and the ideal 1 LSB change between any two adjacent codes in the ADC.

#### Offset Error

The deviation of the first code transition (0000...000) to (0000...001) from the ideal, that is,  $\frac{1}{2}$  LSB.

#### Gain Error

The deviation of the last code transition from the ideal AIN voltage (full scale – 1.5 LSB) after the offset error has been adjusted out.

#### Signal to (Noise + Distortion) Ratio

The measured ratio of signal to (noise + distortion) at the output of the ADC. The signal is the rms amplitude of the fundamental. Noise is the rms sum of all nonfundamental signals up to half the sampling frequency ( $f_s/2$ ), excluding dc.

The ratio is dependent upon the number of quantization levels in the digitization process; the more levels there are, the smaller the quantization noise becomes.

The theoretical signal to (noise + distortion) ratio for an ideal N-bit converter with a sine wave input is given by

$$\text{Signal to (Noise + Distortion)} = (6.02 N + 1.76) \text{ dB}$$

Thus, for a 12-bit converter, this is 74 dB.

#### Total Harmonic Distortion

The ratio of the rms sum of the harmonics to the fundamental.

### DAC SPECIFICATIONS

#### Relative Accuracy

Otherwise known as endpoint linearity, relative accuracy is a measure of the maximum deviation from a straight line passing through the endpoints of the DAC transfer function. It is measured after adjusting for zero error and full-scale error.

#### Voltage Output Settling Time

The amount of time it takes the output to settle to within a 1 LSB level for a full-scale input change.

## OVERVIEW OF THE ARM7TDMI CORE

The ARM7<sup>®</sup> core is a 32-bit reduced instruction set computer (RISC). It uses a single 32-bit bus for instruction and data. The length of the data can be eight bits, 16 bits, or 32 bits. The length of the instruction word is 32 bits.

The ARM7TDMI is an ARM7 core with four additional features.

- T support for the Thumb<sup>®</sup> (16-bit) instruction set.
- D support for debug.
- M support for long multiplications.
- I includes the EmbeddedICE module to support embedded system debugging.

### THUMB MODE (T)

An ARM instruction is 32 bits long. The ARM7TDMI processor supports a second instruction set that has been compressed into 16 bits, called the Thumb instruction set. Faster execution from 16-bit memory and greater code density can usually be achieved by using the Thumb instruction set instead of the ARM instruction set, which makes the ARM7TDMI core particularly suitable for embedded applications.

However, the Thumb mode has two limitations:

- Thumb code typically requires more instructions for the same job. As a result, ARM code is usually best for maximizing the performance of time-critical code.
- The Thumb instruction set does not include some of the instructions needed for exception handling, which automatically switches the core to ARM code for exception handling.

See the ARM7TDMI user guide for details on the core architecture, the programming model, and both the ARM and ARM Thumb instruction sets.

### LONG MULTIPLY (M)

The ARM7TDMI instruction set includes four extra instructions that perform 32-bit by 32-bit multiplication with a 64-bit result and 32-bit by 32-bit multiplication-accumulation (MAC) with a 64-bit result. These results are achieved in fewer cycles than required on a standard ARM7 core.

### EmbeddedICE (I)

EmbeddedICE provides integrated on-chip support for the core. The EmbeddedICE module contains the breakpoint and watchpoint registers that allow code to be halted for debugging purposes. These registers are controlled through the JTAG test port.

When a breakpoint or watchpoint is encountered, the processor halts and enters debug state. Once in a debug state, the processor registers can be inspected as well as the Flash/EE, SRAM, and memory mapped registers.

## EXCEPTIONS

ARM supports five types of exceptions and a privileged processing mode for each type. The five types of exceptions are

- Normal interrupt or IRQ. This is provided to service general-purpose interrupt handling of internal and external events.
- Fast interrupt or FIQ. This is provided to service data transfers or communication channels with low latency. FIQ has priority over IRQ.
- Memory abort.
- Attempted execution of an undefined instruction.
- Software interrupt instruction (SWI). This can be used to make a call to an operating system.

Typically, the programmer defines an interrupt as IRQ, but for higher priority interrupt, that is, faster response time, the programmer can define an interrupt as FIQ.

## ARM REGISTERS

ARM7TDMI has a total of 37 registers: 31 general-purpose registers and six status registers. Each operating mode has dedicated banked registers.

When writing user-level programs, 15 general-purpose, 32-bit registers (R0 to R14), the program counter (R15), and the current program status register (CPSR) are usable. The remaining registers are only used for system-level programming and exception handling.

When an exception occurs, some of the standard registers are replaced with registers specific to the exception mode. All exception modes have replacement banked registers for the stack pointer (R13) and the link register (R14), as represented in Figure 23. The fast interrupt mode has more registers (R8 to R12) for fast interrupt processing. This means that the interrupt processing can begin without the need to save or restore these registers, and therefore, save critical time in the interrupt handling process.

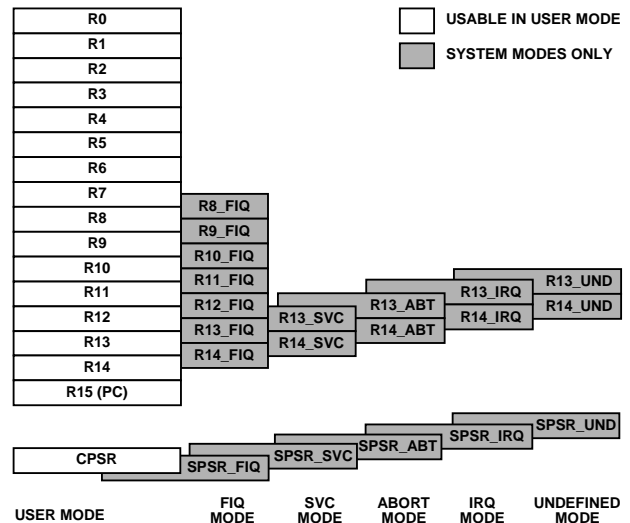

Figure 23. Register Organization

More information relative to the model of the programmer and the ARM7TDMI core architecture can be found in the following materials from ARM:

- DDI0029G, *ARM7TDMI Technical Reference Manual*
- DDI-0100, *ARM Architecture Reference Manual*

### INTERRUPT LATENCY

The worst-case latency for a fast interrupt request (FIQ) consists of the following:

- The longest time the request can take to pass through the synchronizer
- The time for the longest instruction to complete (the longest instruction is an LDM) that loads all the registers including the PC
- The time for the data abort entry
- The time for the FIQ entry

At the end of this time, the ARM7TDMI executes the instruction at 0x1C (FIQ interrupt vector address). The maximum total time is 50 processor cycles, which is just under 1.2  $\mu$ s in a system using a continuous 41.78 MHz processor clock.

The maximum interrupt request (IRQ) latency calculation is similar but must allow for the fact that FIQ has higher priority and can delay entry into the IRQ handling routine for an arbitrary length of time. This time can be reduced to 42 cycles if the LDM command is not used. Some compilers have an option to compile without using this command. Another option is to run the part in Thumb mode where the time is reduced to 22 cycles.

The minimum latency for FIQ or IRQ interrupts is a total of five cycles, which consist of the shortest time the request can take through the synchronizer plus the time to enter the exception mode.

Note that the ARM7TDMI always runs in ARM (32-bit) mode when in privileged modes, for example, when executing interrupt service routines.

## MEMORY ORGANIZATION

The ADuC7124/ADuC7126 incorporate three separate blocks of memory: 32 kB of SRAM and two 64 kB blocks of on-chip Flash/EE memory. There are 126 kB of on-chip Flash/EE memory available to the user, and the remaining 2 kB are reserved for the system kernel. These blocks are mapped as shown in Figure 24.

Note that, by default, after a reset, the Flash/EE memory is mirrored at Address 0x00000000. It is possible to remap the SRAM at Address 0x00000000 by clearing Bit 0 of the REMAP MMR. This remap function is described in more detail in the Flash/EE memory chapter.

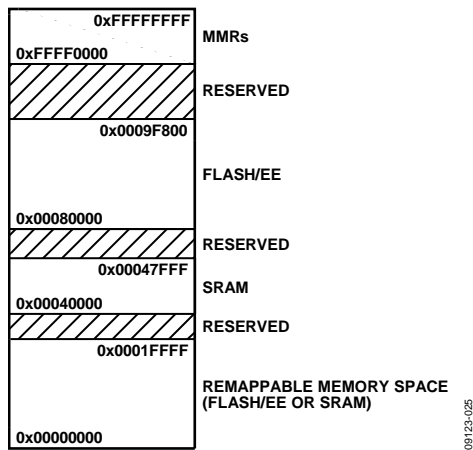

Figure 24. Physical Memory Map

## MEMORY ACCESS

The ARM7 core sees memory as a linear array of a 2<sup>32</sup> byte location where the different blocks of memory are mapped as outlined in Figure 24.

The ADuC7124/ADuC7126 memory organization is configured in little endian format: the least significant byte is located in the lowest byte address and the most significant byte in the highest byte address.

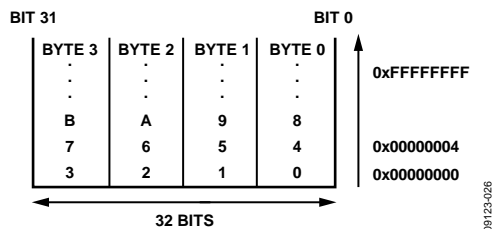

Figure 25. Little Endian Format

## FLASH/EE MEMORY

The 128 kB of Flash/EE are organized as two banks of 32 k × 16 bits. Block 0 starts at Address 0x90000 and finishes at Address 0x9F700. In this block, 31 k × 16 bits is user space and 1 k × 16 bits is reserved for the factory-configured boot page. The page size of this Flash/EE memory is 512 bytes.

Block 1 starts at Address 0x80000 and finishes at Address 0x90000. In this block, all 64 kB are available as user space. The block is arranged in 32 k × 16 bits.

The 126 kB of Flash/EE are available to the user as code and nonvolatile data memory. There is no distinction between data and program because ARM code shares the same space. The real width of the Flash/EE memory is 16 bits, meaning that, in ARM mode (32-bit instruction), two accesses to the Flash/EE are necessary for each instruction fetch. Therefore, it is recommended that Thumb mode be used when executing from Flash/EE memory for optimum access speed. The maximum access speed for the Flash/EE memory is 41.78 MHz in Thumb mode and 20.89 MHz in full ARM mode (see the Execution Time from SRAM and Flash/EE section).

## SRAM

The 32 kB of SRAM are available to the user, organized as 8 k × 32 bits, that is, 16 k words. ARM code can run directly from SRAM at 41.78 MHz, given that the SRAM array is configured as a 32-bit wide memory array (see the Execution Time from SRAM and Flash/EE section).

## MEMORY MAPPED REGISTERS

The memory mapped register (MMR) space is mapped into the upper two pages of the memory array and accessed by indirect addressing through the ARM7 banked registers.

The MMR space provides an interface between the CPU and all on-chip peripherals. All registers except the core registers reside in the MMR area. All shaded locations shown in Figure 26 are unoccupied or reserved locations and should not be accessed by user software. Table 11 to Table 29 show the full MMR memory map.

The access time reading or writing a MMR depends on the advanced microcontroller bus architecture (AMBA) bus used to access the peripheral. The processor has two AMBA buses: the advanced high performance bus (AHB) used for system modules, and the advanced peripheral bus (APB) used for the lower performance peripheral. Access to the AHB is one cycle, and access to the APB is two cycles. All peripherals on the ADuC7124/ADuC7126 are on the APB except the Flash/EE memory and the GPIOs.

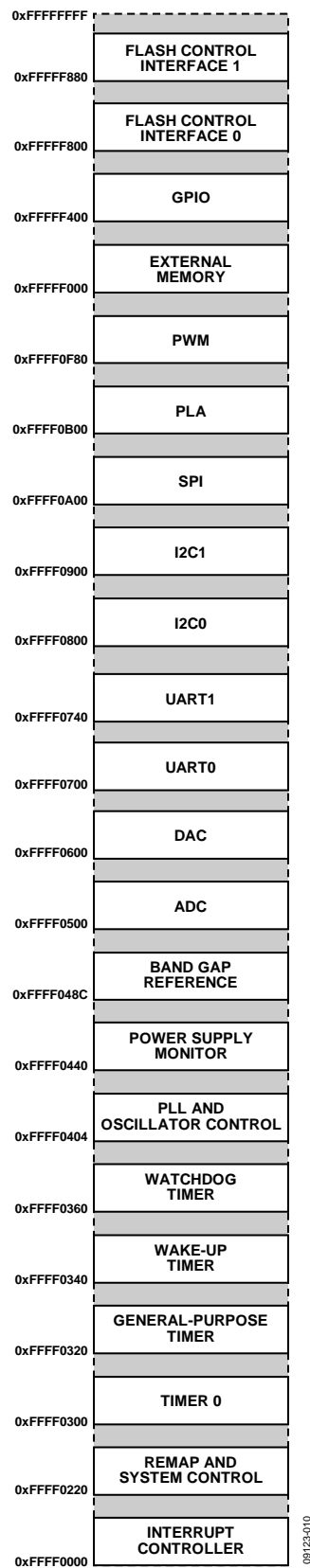

Figure 26. Memory Mapped Registers

Table 11. IRQ Base Address = 0xFFFF0000

Address	Name	Byte	Access Type
0xFFFF0000	IRQSTA	4	R
0xFFFF0004	IRQSIG	4	R
0xFFFF0008	IRQEN	4	R/W
0xFFFF000C	IRQCLR	4	W
0xFFFF0010	SWICFG	4	W
0xFFFF0014	IRQBASE	4	R/W
0xFFFF001C	IRQVEC	4	R
0xFFFF0020	IRQP0	4	R/W
0xFFFF0024	IRQP1	4	R/W
0xFFFF0028	IRQP2	4	R/W
0xFFFF002C	IRQP3	4	R/W
0xFFFF0030	IRQCONN	1	R/W
0xFFFF0034	IRQCONE	4	R/W
0xFFFF0038	IRQCLRE	1	W
0xFFFF003C	IRQSTAN	1	R/W
0xFFFF0100	FIQSTA	4	R
0xFFFF0104	FIQSIG	4	R
0xFFFF0108	FIQEN	4	R/W
0xFFFF010C	FIQCLR	4	W
0xFFFF011C	FIQVEC	4	R
0xFFFF013C	FIQSTAN	1	R/W

Table 12. System Control Base Address = 0xFFFF0200

Address	Name	Byte	Access Type
0xFFFF0220	REMAP	1	R/W
0xFFFF0230	RSTSTA	1	R
0xFFFF0234	RSTCLR	1	W
0xFFFF0248	RSTKEY0	1	W
0xFFFF024C	RSTCFG	1	R/W
0xFFFF0250	RSTKEY1	1	W

Table 13. Timer Base Address = 0xFFFF0300

Address	Name	Byte	Access Type
0xFFFF0300	T0LD	2	R/W
0xFFFF0304	T0VAL	2	R
0xFFFF0308	T0CON	2	R/W
0xFFFF030C	T0CLRI	1	W
0xFFFF0320	T1LD	4	R/W
0xFFFF0324	T1VAL	4	R
0xFFFF0328	T1CON	2	R/W
0xFFFF032C	T1CLRI	1	W
0xFFFF0330	T1CAP	4	R
0xFFFF0340	T2LD	4	R/W
0xFFFF0344	T2VAL	4	R
0xFFFF0348	T2CON	2	R/W
0xFFFF034C	T2CLRI	1	W
0xFFFF0360	T3LD	2	R/W
0xFFFF0364	T3VAL	2	R
0xFFFF0368	T3CON	2	R/W
0xFFFF036C	T3CLRI	1	W

Table 14. PLL/PSM Base Address = 0xFFFF0400

Address	Name	Byte	Access Type
0xFFFF0404	POWKEY1	2	W
0xFFFF0408	POWCON0	1	R/W
0xFFFF040C	POWKEY2	2	W
0xFFFF0410	PLLKEY1	4	W
0xFFFF0414	PLLCON	1	R/W
0xFFFF0418	PLLKEY2	4	W
0xFFFF0434	POWKEY3	2	W
0xFFFF0438	POWCON1	2	R/W
0xFFFF043C	POWKEY4	2	W

Table 15. PSM Base Address = 0xFFFF0440

Address	Name	Byte	Access Type
0xFFFF0440	PSMCON	2	R/W
0xFFFF0444	CMPCON	2	R/W

Table 16. Reference Base Address = 0xFFFF0480

Address	Name	Byte	Access Type
0xFFFF048C	REFCON	1	R/W

Table 17. ADC Base Address = 0xFFFF0500

Address	Name	Byte	Access Type
0xFFFF0500	ADCCON	2	R/W
0xFFFF0504	ADCCP	1	R/W
0xFFFF0508	ADCCN	1	R/W
0xFFFF050C	ADCSTA	1	R
0xFFFF0510	ADCDAT	4	R
0xFFFF0514	ADCRST	1	R/W
0xFFFF0530	ADCGN	2	R/W
0xFFFF0534	ADCOF	2	R/W
0xFFFF0544	TSCON	1	R/W
0xFFFF0548	TEMPREF	2	R/W

Table 18. DAC Address Base = 0xFFFF0600

Address	Name	Byte	Access Type
0xFFFF0600	DAC0CON	1	R/W
0xFFFF0604	DAC0DAT	4	R/W
0xFFFF0608	DAC1CON	1	R/W
0xFFFF060C	DAC1DAT	4	R/W
0xFFFF0610	DAC2CON	1	R/W
0xFFFF0614	DAC2DAT	4	R/W
0xFFFF0618	DAC3CON	1	R/W
0xFFFF061C	DAC3DAT	4	R/W
0xFFFF0650	DACBKEY1	2	W
0xFFFF0654	DACBCFG	1	R/W
0xFFFF0658	DACBKEY2	2	W

Table 19. UART0 Base Address = 0xFFFF0700

Address	Name	Byte	Access Type	Cycle
0xFFFF0700	COM0TX	1	R/W	2
0xFFFF0700	COM0RX	1	R	2
0xFFFF0700	COM0DIV0	1	R/W	2
0xFFFF0704	COM0IEN0	1	R/W	2
0xFFFF0704	COM0DIV1	1	R/W	2
0xFFFF0708	COM0IID0	1	R	2
0xFFFF0708	COM0FCR	1	R/W	2
0xFFFF070C	COM0CON0	1	R/W	2
0xFFFF0710	COM0CON1	1	R/W	2
0xFFFF0714	COM0STA0	2	R	2
0xFFFF0718	COM0STA1	2	R	2
0xFFFF072C	COM0DIV2	2	R/W	2

Table 20. UART1 Base Address = 0xFFFF0740

Address	Name	Byte	Access Type	Cycle
0xFFFF0740	COM1TX	1	R/W	2
0xFFFF0740	COM1RX	1	R	2
0xFFFF0740	COM1DIV0	1	R/W	2
0xFFFF0744	COM1IEN0	1	R/W	2
0xFFFF0744	COM1DIV1	1	R/W	2
0xFFFF0748	COM1IID0	1	R	2
0xFFFF0748	COM1FCR	1	R/W	2
0xFFFF074C	COM1CON0	1	R/W	2
0xFFFF0750	COM1CON1	1	R/W	2
0xFFFF0754	COM1STA0	2	R	2
0xFFFF0758	COM1STA1	2	R	2
0xFFFF076C	COM1DIV2	2	R/W	2

Table 21. I2C0 Base Address = 0xFFFF0800

Address	Name	Byte	Access Type	Cycle
0xFFFF0800	I2C0MCON	2	R/W	2
0xFFFF0804	I2C0MSTA	2	R	2
0xFFFF0808	I2C0MRX	1	R	2
0xFFFF080C	I2C0MTX	2	R/W	2
0xFFFF0810	I2C0MCNT0	2	R/W	2
0xFFFF0814	I2C0MCNT1	1	R	2
0xFFFF0818	I2C0ADRO	1	R/W	2
0xFFFF081C	I2C0ADR1	1	R/W	2
0xFFFF0824	I2C0DIV	2	R/W	2
0xFFFF0828	I2C0SCON	2	R/W	2
0xFFFF082C	I2C0SSTA	2	R	2
0xFFFF0830	I2C0SRX	1	R	2
0xFFFF0834	I2C0STX	1	W	2
0xFFFF0838	I2C0ALT	1	R/W	2
0xFFFF083C	I2C0ID0	1	R/W	2
0xFFFF0840	I2C0ID1	1	R/W	2
0xFFFF0844	I2C0ID2	1	R/W	2
0xFFFF0848	I2C0ID3	1	R/W	2
0xFFFF084C	I2C0FSTA	1	R/W	2

Table 22. I2C1 Base Address = 0xFFFF0900

Address	Name	Byte	Access Type	Cycle
0xFFFF0900	I2C1MCON	2	R/W	2
0xFFFF0904	I2C1MSTA	2	R	2
0xFFFF0908	I2C1MRX	1	R	2
0xFFFF090C	I2C1MTX	2	R/W	2
0xFFFF0910	I2C1MCNT0	2	R/W	2
0xFFFF0914	I2C1MCNT1	1	R	2
0xFFFF0918	I2C1ADR0	1	R/W	2
0xFFFF091C	I2C1ADR1	1	R/W	2
0xFFFF0924	I2C1DIV	2	R/W	2
0xFFFF0928	I2C1SCON	2	R/W	2
0xFFFF092C	I2C1SSTA	2	R	2
0xFFFF0930	I2C1SRX	1	R	2
0xFFFF0934	I2C1STX	1	W	2
0xFFFF0938	I2C1ALT	1	R/W	2
0xFFFF093C	I2C1ID0	1	R/W	2
0xFFFF0940	I2C1ID1	1	R/W	2
0xFFFF0944	I2C1ID2	1	R/W	2
0xFFFF0948	I2C1ID3	1	R/W	2
0xFFFF094C	I2C1FSTA	1	R/W	2

Table 23. SPI Base Address = 0xFFFF0A00

Address	Name	Byte	Access Type	Cycle
0xFFFF0A00	SPISTA	2	R	2
0xFFFF0A04	SPIRX	1	R	2
0xFFFF0A08	SPITX	1	W	2
0xFFFF0A0C	SPIDIV	1	R/W	2
0xFFFF0A10	SPICON	2	R/W	2

Table 24. PLA Base Address = 0xFFFF0B00

Address	Name	Byte	Access Type	Cycle
0xFFFF0B00	PLAELM0	2	R/W	2
0xFFFF0B04	PLAELM1	2	R/W	2
0xFFFF0B08	PLAELM2	2	R/W	2
0xFFFF0B0C	PLAELM3	2	R/W	2
0xFFFF0B10	PLAELM4	2	R/W	2
0xFFFF0B14	PLAELM5	2	R/W	2
0xFFFF0B18	PLAELM6	2	R/W	2
0xFFFF0B1C	PLAELM7	2	R/W	2
0xFFFF0B20	PLAELM8	2	R/W	2
0xFFFF0B24	PLAELM9	2	R/W	2
0xFFFF0B28	PLAELM10	2	R/W	2
0xFFFF0B2C	PLAELM11	2	R/W	2
0xFFFF0B30	PLAELM12	2	R/W	2
0xFFFF0B34	PLAELM13	2	R/W	2
0xFFFF0B38	PLAELM14	2	R/W	2
0xFFFF0B3C	PLAELM15	2	R/W	2
0xFFFF0B40	PLACLK	1	R/W	2
0xFFFF0B44	PLAIRQ	2	R/W	2
0xFFFF0B48	PLAADC	4	R/W	2
0xFFFF0B4C	PLADIN	4	R/W	2
0xFFFF0B50	PLADOUT	4	R	2
0xFFFF0B54	PLALCK	1	W	2

Table 25. PWM Base Address = 0xFFFF0F80

Address	Name	Byte	Access Type	Cycle
0xFFFF0F80	PWMCON0	2	R/W	2
0xFFFF0F84	PWM0COM0	2	R/W	2
0xFFFF0F88	PWM0COM1	2	R/W	2
0xFFFF0F8C	PWM0COM2	2	R/W	2
0xFFFF0F90	PWM0LEN	2	R/W	2
0xFFFF0F94	PWM1COM0	2	R/W	2
0xFFFF0F98	PWM1COM1	2	R/W	2
0xFFFF0F9C	PWM1COM2	2	R/W	2
0xFFFF0FA0	PWM1LEN	2	R/W	2
0xFFFF0FA4	PWM2COM0	2	R/W	2
0xFFFF0FA8	PWM2COM1	2	R/W	2
0xFFFF0FAC	PWM2COM2	2	R/W	2
0xFFFF0FB0	PWM2LEN	2	R/W	2
0xFFFF0FB4	PWMCON1	2	R/W	2
0xFFFF0FB8	PWMCLRI	2	W	2

Table 26. External Memory Base Address = 0xFFFFF000

Address	Name	Byte	Access Type	Cycle
0xFFFFF000	XMCFG	1	R/W	2
0xFFFFF010	XM0CON	1	R/W	2
0xFFFFF014	XM1CON	1	R/W	2
0xFFFFF018	XM2CON	1	R/W	2
0xFFFFF01C	XM3CON	1	R/W	2
0xFFFFF020	XM0PAR	2	R/W	2
0xFFFFF024	XM1PAR	2	R/W	2
0xFFFFF028	XM2PAR	2	R/W	2
0xFFFFF02C	XM3PAR	2	R/W	2

Table 27. GPIO Base Address = 0xFFFF0400

Address	Name	Byte	Access Type	Cycle
0xFFFF400	GP0CON	4	R/W	1
0xFFFF404	GP1CON	4	R/W	1
0xFFFF408	GP2CON	4	R/W	1
0xFFFF40C	GP3CON	4	R/W	1
0xFFFF410	GP4CON	4	R/W	1
0xFFFF420	GP0DAT	4	R/W	1
0xFFFF424	GP0SET	1	W	1
0xFFFF428	GP0CLR	1	W	1
0xFFFF42C	GP0PAR	4	R/W	1
0xFFFF430	GP1DAT	4	R/W	1
0xFFFF434	GP1SET	1	W	1
0xFFFF438	GP1CLR	1	W	1
0xFFFF43C	GP1PAR	4	R/W	1
0xFFFF440	GP2DAT	4	R/W	1
0xFFFF444	GP2SET	1	W	1
0xFFFF448	GP2CLR	1	W	1
0xFFFF44C	GP2PAR	4	R/W	1
0xFFFF450	GP3DAT	4	R/W	1
0xFFFF454	GP3SET	1	W	1
0xFFFF458	GP3CLR	1	W	1
0xFFFF45C	GP3PAR	4	R/W	1
0xFFFF460	GP4DAT	4	R/W	1
0xFFFF464	GP4SET	1	W	1
0xFFFF468	GP4CLR	1	W	1
0xFFFF46C	GP4PAR	4	R/W	1

Table 28. Flash/EE Block 0 Base Address = 0xFFFF800

Address	Name	Byte	Access Type	Cycle
0xFFFF800	FEE0STA	1	R	1
0xFFFF804	FEE0MOD	1	R/W	1
0xFFFF808	FEE0CON	1	R/W	1
0xFFFF80C	FEE0DAT	2	R/W	1
0xFFFF810	FEE0ADR	2	R/W	1
0xFFFF818	FEE0SGN	3	R	1
0xFFFF81C	FEE0PRO	4	R/W	1
0xFFFF820	FEE0HID	4	R/W	1

Table 29. Flash/EE Block 1 Base Address = 0xFFFF880

Address	Name	Byte	Access Type	Cycle
0xFFFF880	FEE1STA	1	R	1
0xFFFF884	FEE1MOD	1	R/W	1
0xFFFF888	FEE1CON	1	R/W	1
0xFFFF88C	FEE1DAT	2	R/W	1
0xFFFF890	FEE1ADR	2	R/W	1
0xFFFF898	FEE1SGN	3	R	1
0xFFFF89C	FEE1PRO	4	R/W	1
0xFFFF8A0	FEE1HID	4	R/W	1

## ADC CIRCUIT OVERVIEW

The analog-to-digital converter is a fast, multichannel, 12-bit ADC. It can operate from 2.7 V to 3.6 V supplies and is capable of providing a throughput of up to 1 MSPS when the clock source is 41.78 MHz. This block provides the user with a multichannel multiplexer, a differential track-and-hold, an on-chip reference, and an ADC.

The ADC consists of a 12-bit successive approximation converter based around two capacitor DACs. Depending on the input signal configuration, the ADC can operate in one of three different modes.

- Fully differential mode, for small and balanced signals
- Single-ended mode, for any single-ended signals
- Pseudo differential mode, for any single-ended signals, taking advantage of the common-mode rejection offered by the pseudo differential input

The converter accepts an analog input range of 0 V to  $V_{REF}$  when operating in single-ended or pseudo differential mode. In fully differential mode, the input signal must be balanced around a common-mode voltage ( $V_{CM}$ ) in the 0 V to  $AV_{DD}$  range with a maximum amplitude of  $2 \times V_{REF}$  (see Figure 27).

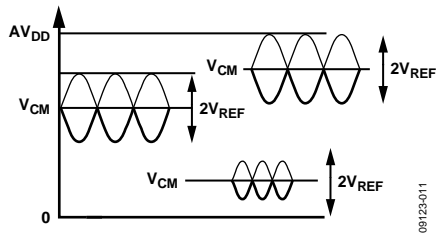

Figure 27. Examples of Balanced Signals in Fully Differential Mode

A high precision, low drift, factory calibrated, 2.5 V reference is provided on chip. An external reference can also be connected as described in the Band Gap Reference section.

Single or continuous conversion modes can be initiated in the software. An external  $CONV_{START}$  pin, an output generated from the on-chip PLA, or a Timer0 or Timer1 overflow can also be used to generate a repetitive trigger for ADC conversions.

A voltage output from an on-chip band gap reference proportional to absolute temperature can also be routed through the front-end ADC multiplexer, effectively an additional ADC channel input. This facilitates an internal temperature sensor channel that measures die temperature.

## TRANSFER FUNCTION

### Pseudo Differential and Single-Ended Modes

In pseudo differential or single-ended mode, the input range is 0 V to  $V_{REF}$ . The output coding is straight binary in pseudo differential and single-ended modes with

$$1 \text{ LSB} = \text{Full-Scale}/4096, \text{ or}$$

$$2.5 \text{ V}/4096 = 0.61 \text{ mV, or}$$

$$610 \text{ } \mu\text{V} \text{ when } V_{REF} = 2.5 \text{ V}$$

The ideal code transitions occur midway between successive integer LSB values (that is,  $\frac{1}{2}$  LSB,  $\frac{3}{2}$  LSB,  $\frac{5}{2}$  LSB, ... ,  $FS - \frac{3}{2}$  LSB). The ideal input/output transfer characteristic is shown in Figure 28.

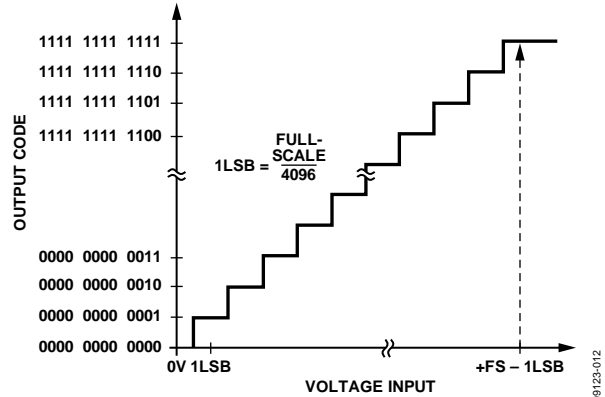

Figure 28. ADC Transfer Function in Pseudo Differential or Single-Ended Mode

### Fully Differential Mode

The amplitude of the differential signal is the difference between the signals applied to the  $V_{IN+}$  and  $V_{IN-}$  pins (that is,  $V_{IN+} - V_{IN-}$ ).  $V_{IN+}$  is selected by the ADCCP register, and  $V_{IN-}$  is selected by the ADCCN register. The maximum amplitude of the differential signal is, therefore,  $-V_{REF}$  to  $+V_{REF}$  p-p (that is,  $2 \times V_{REF}$ ). This is regardless of the common mode (CM). The common mode is the average of the two signals, for example,  $(V_{IN+} + V_{IN-})/2$ , and is, therefore, the voltage that the two inputs are centered on. This results in the span of each input being  $CM \pm V_{REF}/2$ . This voltage must be set up externally, and its range varies with  $V_{REF}$  (see the Driving the Analog Inputs section).

The output coding is twos complement in fully differential mode with  $1 \text{ LSB} = 2 \times V_{REF}/4096$ , or  $2 \times 2.5 \text{ V}/4096 = 1.22 \text{ mV}$  when  $V_{REF} = 2.5 \text{ V}$ . The output result is  $\pm 11$  bits, but this is shifted by one to the right. This allows the result in ADCDAT to be declared as a signed integer when writing C code. The designed code transitions occur midway between successive integer LSB values (that is,  $\frac{1}{2}$  LSB,  $\frac{3}{2}$  LSB,  $\frac{5}{2}$  LSB, ... ,  $FS - \frac{3}{2}$  LSB). The ideal input/output transfer characteristic is shown in Figure 29.

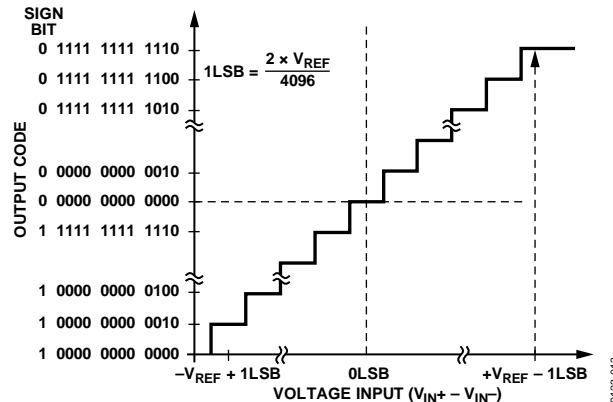

Figure 29. ADC Transfer Function in Differential Mode

**TYPICAL OPERATION**

Once configured via the ADC control and channel selection registers, the ADC converts the analog input and provides a 12-bit result in the ADC data register.

The top four bits are the sign bits. The 12-bit result is placed in Bit 16 to Bit 27 as shown in Figure 30. Again, it should be noted that in fully differential mode, the result is represented in twos complement format. In pseudo differential and single-ended modes, the result is represented in straight binary format.

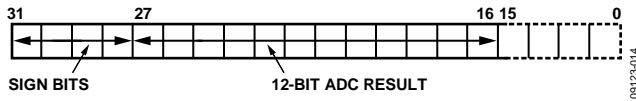

Figure 30. ADC Result Format

The same format is used in DACxDAT, simplifying the software.

**Current Consumption**

The ADC in standby mode, that is, powered up but not converting, typically consumes 640  $\mu$ A. The internal reference adds 140  $\mu$ A. During conversion, the extra current is 0.3  $\mu$ A multiplied by the sampling frequency (in kHz).

**Timing**

Figure 31 gives details of the ADC timing. The user controls the ADC clock speed and the number of acquisition clocks in the ADCCON MMR. By default, the acquisition time is eight clocks, and the clock divider is two. The number of extra clocks (such as bit trial or write) is set to 19, which gives a sampling rate of 774 kSPS. For conversion on temperature sensor, the ADC acquisition time is automatically set to 16 clocks, and the ADC clock divider is set to 32. When using multiple channels including the temperature sensor, the timing settings revert to the user-defined settings after reading the temperature sensor channel.

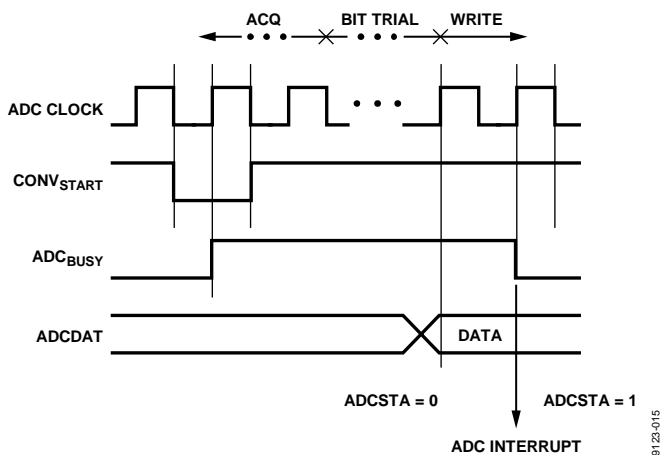

Figure 31. ADC Timing

**MMRS INTERFACE**

The ADC is controlled and configured via the eight MMRs.

**ADCCON Register**

Name: ADCCON  
 Address: 0xFFFF0500  
 Default Value: 0x0600  
 Access: Read/write

ADCCON is an ADC control register that allows the programmer to enable the ADC peripheral, select the mode of operation of the ADC (either in single-ended mode, pseudo differential mode, or fully differential mode), and select the conversion type. This MMR is described in Table 30.

Table 30. ADCCON MMR Bit Descriptions

Bit	Value	Description
[15:14]		Reserved.
13		Set by the user to enable edge trigger mode. Cleared by the user to enable level trigger mode.
[12:10]		ADC clock speed.
	000	$f_{ADC}/1$ . This divider is provided to obtain 1 MSPS ADC with an external clock <41.78 MHz.
	001	$f_{ADC}/2$ (default value).
	010	$f_{ADC}/4$ .
	011	$f_{ADC}/8$ .
	100	$f_{ADC}/16$ .
	101	$f_{ADC}/32$ .
[9:8]		ADC acquisition time.
	00	Two clocks.
	01	Four clocks.
	10	Eight clocks (default value).
	11	16 clocks.
7		Enable start conversion. Set by the user to start any type of conversion command. Cleared by the user to disable a start conversion (clearing this bit does not stop the ADC when continuously converting).
6		Enable ADC <sub>BUSY</sub> . Set by the user to enable the ADC <sub>BUSY</sub> pin. Cleared by the user to disable the ADC <sub>BUSY</sub> pin.
5		ADC power control. Set by the user to place the ADC in normal mode (the ADC must be powered up for at least 5 $\mu$ s before it converts correctly). Cleared by the user to place the ADC in power-down mode.
[4:3]		Conversion mode.
	00	Single-ended mode.
	01	Differential mode.
	10	Pseudo differential mode.
	11	Reserved.

Bit	Value	Description
[2:0]		Conversion type.
	000	Enable CONV <sub>START</sub> pin as a conversion input.
	001	Enable Timer1 as a conversion input.
	010	Enable Timer0 as a conversion input.
	011	Single software conversion. Sets to 000 after conversion (note that Bit 7 of ADCCON MMR should be cleared after starting a single software conversion to avoid further conversions triggered by the CONV <sub>START</sub> pin).
	100	Continuous software conversion.
	101	PLA conversion.
	Other	Reserved.

**ADCCP Register**

Name:	ADCCP
Address:	0xFFFF0504
Default Value:	0x00
Access:	Read/write

ADCCP is an ADC positive channel selection register. This MMR is described in Table 31.

**Table 31. ADCCP<sup>1</sup> MMR Bit Designation**

Bit	Value	Description
[7:5]		Reserved.
[4:0]		Positive channel selection bits.
	00000	ADC0.
	00001	ADC1.
	00010	ADC2.
	00011	ADC3.
	00100	ADC4.
	00101	ADC5.
	00110	ADC6.
	00111	ADC7.
	01000	ADC8.
	01001	ADC9.
	01010	ADC10.
	01011	ADC11.
	01100	DAC0/ADC12.
	01101	DAC1/ADC13.
	01110	DAC2/ADC14.
	01111	DAC3/ADC15.
	10000	Temperature sensor.
	10001	AGND (self-diagnostic feature).
	10010	Internal reference (self-diagnostic feature).
	10011	AV <sub>DD</sub> /2.
	Others	Reserved.

<sup>1</sup>ADC and DAC channel availability depends on part model. See the Ordering Guide for details.

**ADCCN Register**

Name:	ADCCN
Address:	0xFFFF0508
Default Value:	0x01
Access:	Read/write

ADCCN is an ADC negative channel selection register. This MMR is described in Table 32.

**Table 32. ADCCN MMR Bit Designation**

Bit	Value	Description
[7:5]		Reserved.
[4:0]		Negative channel selection bits.
	00000	ADC0.
	00001	ADC1.
	00010	ADC2.
	00011	ADC3.
	00100	ADC4.
	00101	ADC5.
	00110	ADC6.
	00111	ADC7.
	01000	ADC8.
	01001	ADC9.
	01010	ADC10.
	01011	ADC11.
	01100	DAC0/ADC12.
	01101	DAC1/ADC13.
	01110	DAC2/ADC14.
	01111	DAC3/ADC15.
	10000	Reserved.
	10001	AGND.
	10010	Reserved.
	10011	Reserved.
	Others	Reserved.

**ADCSTA Register**

Name:	ADCSTA
Address:	0xFFFF050C
Default Value:	0x00
Access:	Read only

ADCSTA is an ADC status register that indicates when an ADC conversion result is ready. The ADCSTA register contains only one bit, ADCReady (Bit 0), representing the status of the ADC. This bit is set at the end of an ADC conversion, generating an ADC interrupt. It is cleared automatically by reading the ADCDAT MMR. When the ADC is performing a conversion, the status of the ADC can be read externally via the ADC<sub>BUSY</sub> pin. This pin is high during a conversion. When the conversion is finished, ADC<sub>BUSY</sub> goes back low. This information is available

on P0.5 (see the General-Purpose Input/Output section) if enabled in the ADCCON register.

**ADCDAT Register**

Name:	ADCDAT
Address:	0xFFFF0510
Default Value:	0x00000000
Access:	Read only

ADCDAT is an ADC data result register that holds the 12-bit ADC result, as shown in Figure 30.

**ADCRST Register**

Name:	ADCRST
Address:	0xFFFF0514
Default Value:	0x00
Access:	Read/write

ADCRST resets the digital interface of the ADC. Writing any value to this register resets all the ADC registers to their default values.

**ADCGN Register**

Name:	ADCGN
Address:	0xFFFF0530
Default Value:	0x0200
Access:	Read/write

ADCGN is a 10-bit gain calibration register.

**ADCOF Register**

Name:	ADCOF
Address:	0xFFFF0534
Default Value:	0x0200
Access:	Read/write

ADCOF is a 10-bit offset calibration register.

**CONVERTER OPERATION**

The ADC incorporates a successive approximation (SAR) architecture involving a charge-sampled input stage. This architecture can operate in three different modes: differential, pseudo differential, and single-ended.

**Differential Mode**

The ADuC7124/ADuC7126 each contains a successive approximation ADC based on two capacitive DACs. Figure 32 and Figure 33 show simplified schematics of the ADC in acquisition and conversion phases, respectively. The ADC comprises control logic, a SAR, and two capacitive DACs. In Figure 32 (the acquisition phase), SW3 is closed and SW1 and SW2 are in

Position A. The comparator is held in a balanced condition, and the sampling capacitor arrays acquire the differential signal on the input.

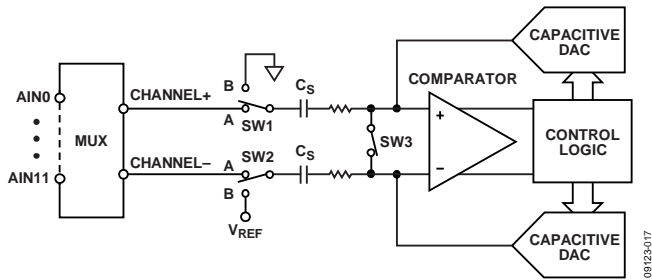

Figure 32. ADC Acquisition Phase

When the ADC starts a conversion, as shown in Figure 33, SW3 opens, and then SW1 and SW2 move to Position B. This causes the comparator to become unbalanced. Both inputs are disconnected once the conversion begins. The control logic and the charge redistribution DACs are used to add and subtract fixed amounts of charge from the sampling capacitor arrays to bring the comparator back into a balanced condition. When the comparator is rebalanced, the conversion is complete. The control logic generates the ADC output code. The output impedances of the sources driving the  $V_{IN+}$  and  $V_{IN-}$  pins must be matched; otherwise, the two inputs have different settling times, resulting in errors.

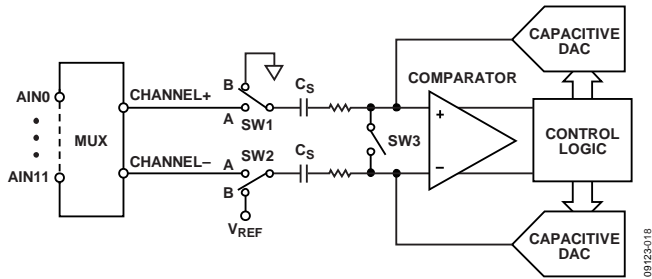

Figure 33. ADC Conversion Phase

**Pseudo Differential Mode**

In pseudo differential mode, Channel- is linked to the ADCNEG pin of the ADuC7124/ADuC7126. In Figure 34, ADCNEG is represented as  $V_{IN-}$ . SW2 switches between A (Channel-) and B ( $V_{REF}$ ). The ADCNEG pin must be connected to ground or to a low voltage. The input signal on  $V_{IN+}$  can then vary from  $V_{IN-}$  to  $V_{REF} + V_{IN-}$ . Note that  $V_{IN-}$  must be chosen so that  $V_{REF} + V_{IN-}$  do not exceed  $AV_{DD}$ .

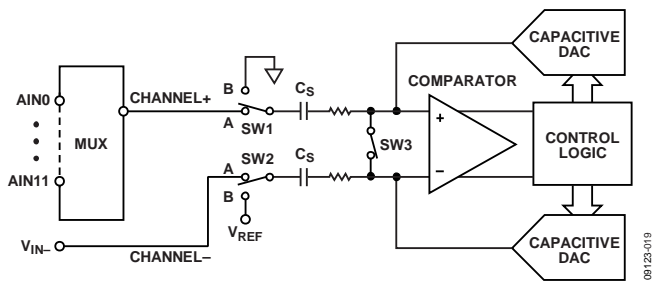

Figure 34. ADC in Pseudo Differential Mode

**Single-Ended Mode**

In single-ended mode, SW2 is always connected internally to ground. The  $V_{IN-}$  pin can be floating. The input signal range on  $V_{IN+}$  is 0 V to  $V_{REF}$ .

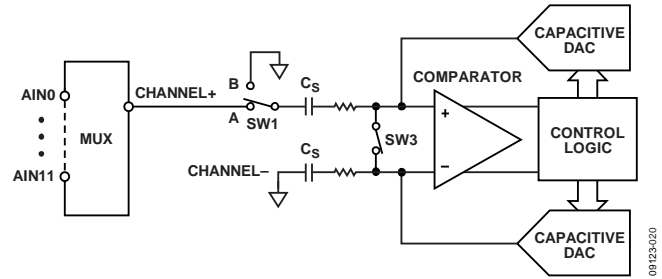

Figure 35. ADC in Single-Ended Mode

**Analog Input Structure**

Figure 36 shows the equivalent circuit of the analog input structure of the ADC. The four diodes provide ESD protection for the analog inputs. Care must be taken to ensure that the analog input signals never exceed the supply rails by more than 300 mV; this can cause these diodes to become forward-biased and start conducting into the substrate. These diodes can conduct up to 10 mA without causing irreversible damage to the part.

The C1 capacitors in Figure 36 are typically 4 pF and can be primarily attributed to pin capacitance. The resistors are lumped components made up of the on resistance of the switches. The value of these resistors is typically about 100  $\Omega$ . The C2 capacitors are the sampling capacitors of the ADC and typically have a capacitance of 16 pF.

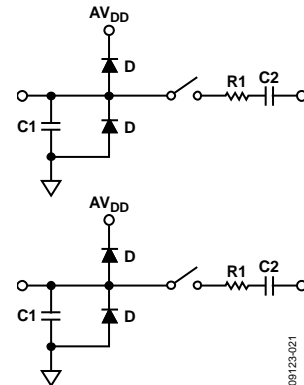

Figure 36. Equivalent Analog Input Circuit Conversion Phase: Switches Open, Track Phase: Switches Closed

For ac applications, removing high frequency components from the analog input signal is recommended by using an RC low-pass filter on the relevant analog input pins. In applications where harmonic distortion and signal-to-noise ratio are critical, the analog input should be driven from a low impedance source. Large source impedances significantly affect the ac performance of the ADC. This can necessitate the use of an input buffer amplifier. The choice of the op amp is a function of the particular application. Figure 37 and Figure 38 give an example of the ADC front end.

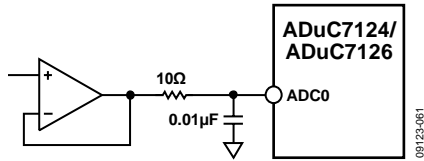

Figure 37. Buffering Single-Ended/Pseudo Differential Input

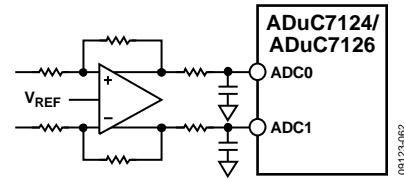

Figure 38. Buffering Differential Inputs

When no amplifier is used to drive the analog input, the source impedance should be limited to values lower than 1 kΩ. The maximum source impedance depends on the amount of total harmonic distortion (THD) that can be tolerated. The THD increases as the source impedance increases and the performance degrades.

### DRIVING THE ANALOG INPUTS

Internal or external references can be used for the ADC. In differential mode of operation, there are restrictions on the common-mode input signal ( $V_{CM}$ ), which is dependent upon the reference value and supply voltage used to ensure that the signal remains within the supply rails. Table 33 gives some calculated  $V_{CM}$  minimum and  $V_{CM}$  maximum values.

Table 33.  $V_{CM}$  Ranges

$V_{DD}$	$V_{REF}$	$V_{CM}$ Minimum	$V_{CM}$ Maximum	Signal Peak-to-Peak
3.3 V	2.5 V	1.25 V	2.05 V	2.5 V
	2.048 V	1.024 V	2.276 V	2.048 V
	1.25 V	0.75 V	2.55 V	1.25 V
3.0 V	2.5 V	1.25 V	1.75 V	2.5 V
	2.048 V	1.024 V	1.976 V	2.048 V
	1.25 V	0.75 V	2.25 V	1.25 V

## CALIBRATION

By default, the factory-set values written to the ADC offset (ADCOF) and gain coefficient registers (ADCGN) yield optimum performance in terms of end-point errors and linearity for standalone operation of the part (see the Specifications section). If system calibration is required, it is possible to modify the default offset and gain coefficients to improve end-point errors, but note that any modification to the factory-set ADCOF and ADCGN values can degrade ADC linearity performance.

For system offset error correction, the ADC channel input stage must be tied to AGND. A continuous software ADC conversion loop must be implemented by modifying the value in ADCOF until the ADC result (ADCDAT) reads Code 0 to Code 1. If the ADCDAT value is greater than 1, ADCOF should be decremented until ADCDAT reads Code 0 to Code 1. Offset error correction is done digitally and has a resolution of 0.25 LSB and a range of  $\pm 3.125\%$  of  $V_{REF}$ .

For system gain error correction, the ADC channel input stage must be tied to  $V_{REF}$ . A continuous software ADC conversion loop must be implemented to modify the value in ADCGN until the ADC result (ADCDAT) reads Code 4094 to Code 4095. If the ADCDAT value is less than 4094, ADCGN should be incremented until ADCDAT reads Code 4094 to Code 4095. Similar to the offset calibration, the gain calibration resolution is 0.25 LSB with a range of  $\pm 3\%$  of  $V_{REF}$ .

## TEMPERATURE SENSOR

The ADuC7124/ADuC7126 provide voltage outputs from an on-chip band gap reference that is proportional to absolute temperature. This voltage output can also be routed through the front-end ADC multiplexer (effectively, an additional ADC channel input), facilitating an internal temperature sensor channel, measuring die temperature.

An ADC temperature sensor conversion differs from a standard ADC voltage. The ADC performance specifications do not apply to the temperature sensor.

Chopping of the internal amplifier must be enabled using the TSCON register. To enable this mode, the user must set Bit 0 of TSCON. The user must also take two consecutive ADC readings and average them in this mode.

The ADCCON register must be configured to 0x37A3.

To calculate die temperature, use the following formula:

$$T - T_{REF} = (V_{ADC} - V_{TREF}) \times K$$

where:

$T$  is the temperature result.

$T_{REF} = 25^\circ\text{C}$ .

For the ADuC7124,  $V_{TREF} = 1.415\text{ V}$  and for the ADuC7126,  $V_{TREF} = 1.392\text{ V}$ , which corresponds to  $T_{REF} = 25^\circ\text{C}$ , as described in Table 1.

$V_{ADC}$  is the average ADC result from two consecutive conversions.

$K$  is the gain of the ADC in temperature sensor mode as determined by characterization data.  $K = 0.2555^\circ\text{C}/\text{mV}$  for ADuC7124.  $K = 0.2212^\circ\text{C}/\text{mV}$  for ADuC7126. This corresponds to the 1/voltage temperature coefficient specification from Table 1.

Using the default values from Table 1 and without any calibration, this equation becomes

$$T - 25^\circ\text{C} = (V_{ADC} - 1415) \times 0.2555 \text{ for ADuC7124}$$

$$T - 25^\circ\text{C} = (V_{ADC} - 1392) \times 0.2212 \text{ for ADuC7126}$$

where  $V_{ADC}$  is in mV.

For better accuracy, the user should perform a single point calibration at a controlled temperature value.

For the calculation with no calibration, use  $25^\circ\text{C}$  and 1415 mV for the ADuC7124 and 1392mV for the ADuC7126. The idea of a single point calibration is to use other known ( $T_{REF}$ ,  $V_{TREF}$ ) values to replace the common  $T = 25^\circ\text{C}$  and 1415 mV for the ADuC7124 and 1392 mV for the ADuC7126 for every part.

For some users, it is not possible to obtain such a known pair.

For such cases, the ADuC7124/ADuC7126 comes with a single point calibration value loaded in the TEMPREF register. For more details on this register, see Table 35. During production testing of the ADuC7124/ADuC7126, the TEMPREF register is loaded with an offset adjustment factor. Each part has a different value in the TEMPREF register. Using this single point calibration, the same formula is still used.

$$T - T_{REF} = (V_{ADC} - V_{TREF}) \times K$$

where:

$T_{REF} = 25^\circ\text{C}$  but is not guaranteed.

$V_{TREF}$  can be calculated using the TEMPREF register.

### TSCON Register

Name: TSCON

Address: 0xFFFF0544

Default Value: 0x00

Access: Read/write

**Table 34. TSCON MMR Bit Descriptions**

Bit	Description
[7:1]	Reserved.
0	Temperature sensor chop enable bit. This bit must be set. This bit is set to 1 to enable chopping of the internal amplifier to the ADC. This bit is cleared to disable chopping. This results in incorrect temperature sensor readings. This bit is cleared by default.

**TEMPREF Register**

Name:	TEMPREF
Address:	0xFFFF0548
Default Value:	0XXXXX
Access:	Read/write

**Table 35. TEMPREF MMR Bit Descriptions**

Bit	Description
[15:9]	Reserved.
8	Temperature reference voltage sign bit.
[7:0]	Temperature sensor offset calibration voltage. To calculate the $V_{TEMP}$ from the TEMPREF register, perform the following calculation: If TEMPREF sign is negative, $C_{TREF} = 2292 - TEMPREF[7:0]$ where $TEMPREF[8] = 1$ Or If TEMPREF sign is positive, $C_{TREF} = TEMPREF[7:0] + 2292$ where $TEMPREF[8] = 0$ . Finally, $V_{TREF} = ((C_{TREF} \times V_{REF})/4096) \times 1000$ Insert $V_{TREF}$ into $T - T_{REF} = (V_{ADC} - V_{TREF}) \times K$ Note that the ADC Code Value 2292 is a default value when using the TEMPREF register. It is not an exact value and must only be used with the TEMPREF register.

**BAND GAP REFERENCE**

Each ADuC7124/ADuC7126 provides on-chip band gap references of 2.5 V, which can be used for the ADC and DAC. This internal reference also appears on the  $V_{REF}$  pin. When using the internal reference, a 0.47  $\mu$ F capacitor must be connected from the external  $V_{REF}$  pin to AGND to ensure stability and fast

response during ADC conversions. This reference can also be connected to an external pin ( $V_{REF}$ ) and used as a reference for other circuits in the system. An external buffer is required because of the low drive capability of the  $V_{REF}$  output ( $<5 \mu$ A). A programmable option also allows an external reference input on the  $V_{REF}$  pin. Note that it is not possible to disable the internal reference. Therefore, the external reference source must be capable of overdriving the internal reference source.

**REFCON Register**

Name:	REFCON
Address:	0xFFFF048C
Default Value:	0x00
Access:	Read/write

The band gap reference interface consists of an 8-bit MMR REFCON, described in Table 36.

**Table 36. REFCON MMR Bit Descriptions**

Bit	Description
[7:2]	Reserved.
1	Internal reference power-down bit. Set this bit to 1 to power down the internal reference source. This bit should be set when connecting an external reference source. Clear this bit to enable the internal reference. This bit is cleared by default.
0	Internal reference output enable. Set by the user to connect the internal 2.5 V reference to the $V_{REF}$ pin. The reference can be used for an external component but must be buffered. Cleared by the user to disconnect the reference from the $V_{REF}$ pin.

To connect an external reference source to the ADuC7124/ADuC7126, configure REFCON = 0x00. ADC and the DACs can be configured to use same or a different reference resource (see Table 66).

## NONVOLATILE FLASH/EE MEMORY

The ADuC7124/ADuC7126 incorporate Flash/EE memory technology on-chip to provide the user with nonvolatile, in-circuit reprogrammable memory space.

Like EEPROM, flash memory can be programmed in-system at a byte level, although it must first be erased. The erase is performed in page blocks. As a result, flash memory is often and more correctly referred to as Flash/EE memory.

Overall, Flash/EE memory represents a step closer to the ideal memory device that includes nonvolatility, in-circuit programmability, high density, and low cost. Incorporated in the ADuC7124/ADuC7126, Flash/EE memory technology allows the user to update program code space in-circuit, without the need to replace one-time programmable (OTP) devices at remote operating nodes.

### Flash/EE Memory

The ADuC7124/ADuC7126 contain two 64 kB arrays of Flash/EE memory. In flash Block 0, the lower 62 kB is available to the user, and the upper 2 kB of this Flash/EE program memory array contain permanently embedded firmware, allowing in-circuit serial download. The 2 kB of embedded firmware also contain a power-on configuration routine that downloads factory calibrated coefficients to the various calibrated peripherals (band gap references and so on). This 2 kB embedded firmware is hidden from user code. It is not possible for the user to read, write, or erase this page. In flash Block 1, all 64 kB of Flash/EE memory are available to the user.

The 126 kB of Flash/EE memory can be programmed in-circuit, using the serial download mode or the JTAG mode provided.

### Flash/EE Memory Reliability

The Flash/EE memory arrays on the parts are fully qualified for two key Flash/EE memory characteristics: Flash/EE memory cycling endurance and Flash/EE memory data retention.

Endurance quantifies the ability of the Flash/EE memory to be cycled through many program, read, and erase cycles. A single endurance cycle is composed of four independent, sequential events, defined as

1. Initial page erase sequence.
2. Read/verify sequence (single Flash/EE).
3. Byte program sequence memory.
4. Second read/verify sequence (endurance cycle).

In reliability qualification, every half word (16-bit wide) location of the three pages (top, middle, and bottom) in the Flash/EE memory is cycled 10,000 times from 0x0000 to 0xFFFF. As indicated in Table 1, the Flash/EE memory endurance qualification is carried out in accordance with JEDEC Retention Lifetime Specification A117 over the industrial temperature range of  $-40^{\circ}$  to  $+125^{\circ}\text{C}$ . The results allow the specification of a minimum endurance figure over a supply temperature of 10,000 cycles.

Retention quantifies the ability of the Flash/EE memory to retain its programmed data over time. Again, the parts are qualified in accordance with the formal JEDEC Retention Lifetime Specification (A117) at a specific junction temperature ( $T_j = 85^{\circ}\text{C}$ ). As part of this qualification procedure, the Flash/EE memory is cycled to its specified endurance limit (see the Flash/EE Memory section) before data retention is characterized. This means that the Flash/EE memory is guaranteed to retain its data for its fully specified retention lifetime every time the Flash/EE memory is reprogrammed. In addition, note that retention lifetime, based on the activation energy of 0.6 eV, derates with  $T_j$  as shown in Figure 39.

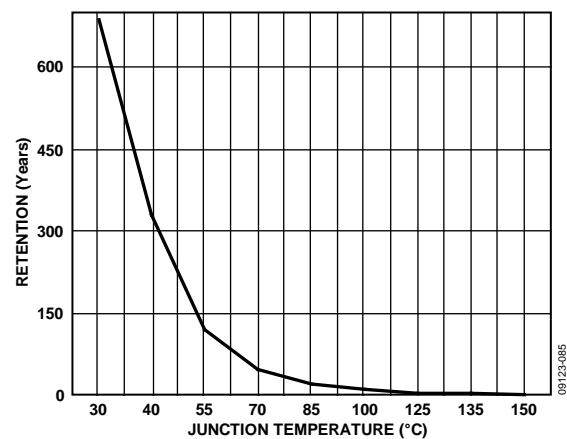

Figure 39. Flash/EE Memory Data Retention

## PROGRAMMING

The 126 kB of Flash/EE memory can be programmed in-circuit, using the serial download mode or the provided JTAG mode.

### Serial Downloading (In-Circuit Programming)

The ADuC7124/ADuC7126 facilitate code download via the standard UART serial port. It is only available on UART0 (P1.0 and P1.1). The parts enter serial download mode after a reset or power cycle if the BM pin is pulled low through an external 1 k $\Omega$  resistor. When in serial download mode, the user can download code to the full 126 kB of Flash/EE memory while the device is in-circuit in its target application hardware. An executable PC serial download is provided as part of the development system for serial downloading via the UART. The AN-724 application note describes the UART download protocol.

### Downloading (In-Circuit Programming) via I<sup>2</sup>C

The ADuC7126BSTZ126I and ADuC7126BSTZ126IRL models facilitate code download via the the I<sup>2</sup>C port. The models enter download mode after a reset or power cycle if the BM pin is pulled low through an external 1 k $\Omega$  resistor and Flash Address 0x80014 = 0xFFFFFFFF. Once in download mode, the user can download code to the full 126 kB of Flash/EE memory while the device is in-circuit in its target application hardware. An executable PC I<sup>2</sup>C download is provided as part of the development system

for serial downloading via the I<sup>2</sup>C. A USB-to-I<sup>2</sup>C download dongle can be purchased from Analog Devices, Inc. This board connects to the USB port of a PC and to the I<sup>2</sup>C port of the ADuC7126. The part number is USB-I2C/LIN-CONV-Z.

The AN-806 Application Note describes the protocol for serial downloading via the I<sup>2</sup>C in more detail.

### JTAG Access

The JTAG protocol uses the on-chip JTAG interface to facilitate code download and debug.

To access the part via the JTAG interface, the P0.0/BM pin must be set high.

When debugging, user code should not write to the P0.1, P0.2, and P0.3 pins. If user code toggles any of these pins, JTAG debug pods are not able to connect to the ADuC7124/ADuC7126. If this happens, mass erase the part using the UART/I<sup>2</sup>C downloader.

### FLASH/EE MEMORY SECURITY

The 126 kB of Flash/EE memory available to the user can be read and write protected. Bit 31 of the FEE0PRO/FEE0HID MMR protects the 62 kB of Block 0 from being read through JTAG and in UART programming mode. The other 31 bits of this register protect writing to the Flash/EE memory; each bit protects four pages, that is, 2 kB. Write protection is activated for all access types. FEE1PRO and FEE1HID, similarly, protect flash Block 1. Bit 31 of the FEE1PRO/FEE1HID MMR protects the 64 kB of Block 1 from being read through JTAG. Bit 30 protects writing to the top 8 pages of Block 1. The other 30 bits of this register protect writing to the Flash/EE memory; each bit protects four pages, that is, 2 kB

### Three Levels of Protection

- Protection can be set and removed by writing directly into FEExHID MMR. This protection does not remain after reset.
- Protection can be set by writing into FEExPRO MMR. It takes effect only after a save protection command (0x0C) and a reset. The FEExPRO MMR is protected by a key to avoid direct access. The key is saved once and must be entered again to modify FEExPRO. A mass erase sets the key back to 0xFFFF but also erases all the user code.
- Flash can be permanently protected by using the FEExPRO MMR and a particular key value of 0xDEADDEAD. Entering the key again to modify the FEExPRO register is not allowed.

### Sequence to Write the Key

1. Write the bit in FEExPRO corresponding to the page to be protected.
2. Enable key protection by setting Bit 6 of FEExMOD (Bit 5 must equal 0).
3. Write a 32-bit key in FEExADR and FEExDAT.
4. Run the write key command 0x0C in FEExCON; wait for the read to be successful by monitoring FEExSTA.
5. Reset the part.

To remove or modify the protection, the same sequence is used with a modified value of FEExPRO. If the key chosen is the value 0xDEAD, the memory protection cannot be removed. Only a mass erase unprotects the part, but it also erases all user code.

The sequence to write the key is illustrated in the following example (this protects writing Page 4 to Page 7 of the Flash):

```
FEExPRO=0xFFFFFFFF; //Protect Page 4 to 7
FEExMOD=0x48; //Write key enable
FEExADR=0x1234; //16 bit key value
FEExDAT=0x5678; //16 bit key value
FEExCON= 0x0C; //Write key command
```

The same sequence should be followed to protect the part permanently with FEExADR = 0xDEAD and FEExDAT = 0xDEAD.

### FLASH/EE CONTROL INTERFACE

Table 37. FEE0STA Register

Name	Address	Default Value	Access
FEE0STA	0xFFFFF800	0x0000	R

Table 38. FEE0MOD Register

Name	Address	Default Value	Access
FEE0MOD	0xFFFFF804	0x80	R/W

Table 39. FEE0CON Register

Name	Address	Default Value	Access
FEE0CON	0xFFFFF808	0x00	R/W

Table 40. FEE0DAT Register

Name	Address	Default Value	Access
FEE0DAT	0xFFFFF80C	0xFFFF	R/W

FEE0DAT is a 16-bit data register.

Table 41. FEE0ADR Register

Name	Address	Default Value	Access
FEE0ADR	0xFFFFF810	0x0000	R/W

FEE0ADR is a 16-bit address register.

Table 42. FEE0SGN Register

Name	Address	Default Value	Access
FEE0SGN	0xFFFFF818	0xFFFF	R

FEE0SGN is a 24-bit code signature.

Table 43. FEE0PRO Register

Name	Address	Default Value	Access
FEE0PRO	0xFFFFF81C	0x00000000	R/W

FEE0PRO provides protection following subsequent reset MMR. It requires a software key (see Table 56).

Table 44. FEE0HID Register

Name	Address	Default Value	Access
FEE0HID	0xFFFFF820	0xFFFFFFFF	R/W

FEE0HID provides immediate protection MMR. It does not require any software keys (see Table 56).

Table 45. FEE1STA Register

Name	Address	Default Value	Access
FEE1STA	0xFFFFF880	0x0000	R

Table 46. FEE1MOD Register

Name	Address	Default Value	Access
FEE1MOD	0xFFFFF884	0x80	R/W

Table 47. FEE1CON Register

Name	Address	Default Value	Access
FEE1CON	0xFFFFF888	0x00	R/W

Table 48. FEE1DAT Register

Name	Address	Default Value	Access
FEE1DAT	0xFFFFF88C	0XXXXX	R/W

FEE1DAT is a 16-bit data register.

Table 49. FEE1ADR Register

Name	Address	Default Value	Access
FEE1ADR	0xFFFFF890	0x0000	R/W

FEE1ADR is a 16-bit address register.

Table 50. FEE1SGN Register

Name	Address	Default Value	Access
FEE1SGN	0xFFFFF898	0FFFFFFF	R

FEE1SGN is a 24-bit code signature.

Table 51. FEE1PRO Register

Name	Address	Default Value	Access
FEE1PRO	0xFFFFF89C	0x00000000	R/W

FEE1PRO provides protection following subsequent reset MMR. It requires a software key (see Table 57).

Table 52. FEE1HID Register

Name	Address	Default Value	Access
FEE1HID	0xFFFFF8A0	0xFFFFFFFF	R/W

FEE1HID provides immediate protection MMR. It does not require any software keys (see Table 57).

#### Command Sequence for Executing a Mass Erase

```
FEE0DAT = 0x3CFF;
FEE0ADR = 0xFFC3;
FEE0MOD = FEE0MOD|0x8; //Erase key enable
FEE0CON = 0x06;          //Mass erase
command
```

Table 53. FEEExSTA MMR Bit Descriptions

Bit	Description
[15:6]	Reserved.
5	Reserved.
4	Reserved.
3	Flash/EE interrupt status bit. Set automatically when an interrupt occurs, that is, when a command is complete and the Flash/EE interrupt enable bit in the FEEExMOD register is set. Cleared when reading the FEEExSTA register.
2	Flash/EE controller busy. Set automatically when the controller is busy. Cleared automatically when the controller is not busy.
1	Command fail. Set automatically when a command completes unsuccessfully. Cleared automatically when reading the FEEExSTA register.
0	Command complete. Set by MicroConverter when a command is complete. Cleared automatically when reading the FEEExSTA register.

Table 54. FEEExMOD MMR Bit Descriptions

Bit	Description
[7:5]	Reserved.
4	Flash/EE interrupt enable. Set by the user to enable the Flash/EE interrupt. The interrupt occurs when a command is complete. Cleared by the user to disable the Flash/EE interrupt.
3	Erase/write command protection. Set by the user to enable the erase and write commands. Cleared to protect the Flash/EE memory against the erase/write command.
2	Reserved. Should always be set to 0 by the user.
[1:0]	Flash/EE wait states. Both Flash/EE blocks must have the same wait state value for any change to take effect.

Table 55. Command Codes in FEEExCON

Code	Command	Description
0x00 <sup>1</sup>	Null	Idle state.
0x01 <sup>1</sup>	Single read	Load FEEExDAT with the 16-bit data indexed by FEEExADR.
0x02 <sup>1</sup>	Single write	Write FEEExDAT at the address pointed to by FEEExADR. This operation takes 50 $\mu$ s.
0x03 <sup>1</sup>	Erase/write	Erase the page indexed by FEEExADR and write FEEExDAT at the location pointed to by FEEExADR. This operation takes 20 ms.
0x04 <sup>1</sup>	Single verify	Compare the contents of the location pointed to by FEEExADR to the data in FEEExDAT. The result of the comparison is returned in FEEExSTA, Bit 1.
0x05 <sup>1</sup>	Single erase	Erase the page indexed by FEEExADR.
0x06 <sup>1</sup>	Mass erase	Erase user space. The 2 kB of kernel are protected in Block 0. This operation takes 2.48 sec. To prevent accidental execution, a command sequence is required to execute this instruction.
0x07	Reserved	Reserved.
0x08	Reserved	Reserved.
0x09	Reserved	Reserved.
0x0A	Reserved	Reserved.
0x0B	Signature	Gives a signature of the 64 kB of Flash/EE in the 24-bit FEEExSIGN MMR. This operation takes 32,778 clock cycles.
0x0C	Protect	This command can be run only once. The value of FEEExPRO is saved and can be removed only with a mass erase (0x06) or with the key.
0x0D	Reserved	Reserved.
0x0E	Reserved	Reserved.
0x0F	Ping	No operation, interrupt generated.

<sup>1</sup> The FEEExCON register always reads 0x07 immediately after execution of any of these commands.

**Table 56. FEE0PRO and FEE0HID MMR Bit Descriptions**

Bit	Description
31	Read protection. Cleared by the user to protect Block 0. Set by the user to allow reading of Block 0.
[30:0]	Write protection for Page 123 to Page 0. Each bit protects a group of 4 pages. Cleared by the user to protect the pages when writing to flash. Thus preventing an accidental write to specific pages in flash. Set by the user to allow writing to the pages.

**Table 57. FEE1PRO and FEE1HID MMR Bit Descriptions**

Bit	Description
31	Read protection. Cleared by the user to protect Block 1. Set by the user to allow reading of Block 1.
30	Write protection for Page 127 to Page 120. Cleared by the user to protect the pages when writing to flash. Thus preventing an accidental write to specific pages in flash. Set by the user to allow writing to the pages.
[29:0]	Write protection for Page 119 to Page 116 and for Page 0 to Page 3. Cleared by the user to protect the pages in writing. Set by the user to allow writing to the pages.

**EXECUTION TIME FROM SRAM AND FLASH/EE**

This section describes SRAM and Flash/EE access times during execution for applications where execution time is critical.

**Execution from SRAM**

Fetching instructions from SRAM takes one clock cycle because the access time of the SRAM is 2 ns, and a clock cycle is 24 ns minimum. However, if the instruction involves reading or writing data to memory, one extra cycle must be added if the data is in SRAM (or three cycles if the data is in Flash/EE): one cycle to execute the instruction and two cycles to get the 32-bit data from Flash/EE. A control flow instruction (a branch instruction, for example) takes one cycle to fetch but also takes two cycles to fill the pipeline with the new instructions.

**Execution from Flash/EE**

Because the Flash/EE width is 16 bits and access time for 16-bit words is 22 ns, execution from Flash/EE cannot be done in one cycle (as can be done from SRAM when the CD bit = 0). Also, some dead times are needed before accessing data for any value of the CD bits.

In ARM mode, where instructions are 32 bits, two cycles are needed to fetch any instruction when CD = 0. In Thumb mode, where instructions are 16 bits, one cycle is needed to fetch any instruction.

Timing is identical in both modes when executing instructions that involve using the Flash/EE for data memory. If the instruction to be executed is a control flow instruction, an extra cycle

is needed to decode the new address of the program counter, and then four cycles are needed to fill the pipeline. A data processing instruction involving only the core register does not require any extra clock cycles. However, if it involves data in Flash/EE, an extra clock cycle is needed to decode the address of the data, and two cycles are needed to get the 32-bit data from Flash/EE. An extra cycle must also be added before fetching another instruction. Data transfer instructions are more complex and are summarized in Table 58.

**Table 58. Execution Cycles in ARM/Thumb Mode**

Instructions	Fetch Cycles	Dead Time	Data Access	Dead Time
LD <sup>1</sup>	2/1	1	2	1
LDH	2/1	1	1	1
LDM/PUSH	2/1	N <sup>2</sup>	2 × N <sup>2</sup>	N <sup>1</sup>
STR <sup>1</sup>	2/1	1	2 × 20 ns	1
STRH	2/1	1	20 ns	1
STRM/POP	2/1	N <sup>1</sup>	2 × N × 20 ns <sup>1</sup>	N <sup>1</sup>

<sup>1</sup> The SWAP instruction combines an LD and STR instruction with only one fetch, giving a total of eight cycles + 40 ns.

<sup>2</sup> N is the number of data bytes to load or store in the multiple load/store instruction (1 < N ≤ 16).

**RESET AND REMAP**

The ARM exception vectors are all situated at the bottom of the memory array, from Address 0x00000000 to Address 0x00000020, as shown in Figure 40.

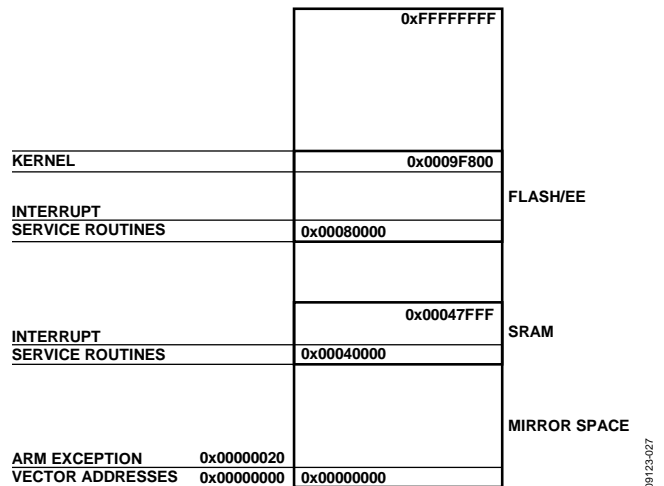

Figure 40. Remap for Exception Execution

By default, and after any reset, the Flash/EE is mirrored at the bottom of the memory array. The remap function allows the programmer to mirror the SRAM at the bottom of the memory array, which facilitates execution of exception routines from SRAM instead of from Flash/EE. This means exceptions are executed twice as fast, being executed in 32-bit ARM mode with 32-bit wide SRAM instead of 16-bit wide Flash/EE memory.

**Table 59. REMAP MMR Bit Descriptions**  
(Address = 0xFFFF0220. Default Value = 0x00)

Bit	Name	Description
0	Remap	Remap bit. Set by the user to remap the SRAM to Address 0x00000000. Cleared automatically after reset to remap the Flash/EE memory to Address 0x00000000.

#### Remap Operation

When a reset occurs on the ADuC7124/ADuC7126, execution automatically starts in factory programmed, internal configuration code. This kernel is hidden and cannot be accessed by user code. If the part is in normal mode (BM pin is high), it executes the power-on configuration routine of the kernel and then jumps to the reset vector address, 0x00000000, to execute the reset exception routine of the user.

Because the Flash/EE is mirrored at the bottom of the memory array at reset, the reset interrupt routine must always be written in Flash/EE.

The remap is done from Flash/EE by setting Bit 0 of the REMAP register. Caution must be taken to execute this command from Flash/EE, above Address 0x00080020, and not from the bottom of the array, because this is replaced by the SRAM.

This operation is reversible. The Flash/EE can be remapped at Address 0x00000000 by clearing Bit 0 of the REMAP MMR. Caution must again be taken to execute the remap function from outside the mirrored area. Any type of reset remaps the Flash/EE memory at the bottom of the array.

#### Reset Operation

There are four kinds of reset: external, power-on, watchdog expiration, and software force. The RSTSTA register indicates the source of the last reset, and RSTCLR allows clearing of the RSTSTA register. These registers can be used during a reset exception service routine to identify the source of the reset. If RSTSTA is null, the reset is external.

The RSTCFG register allows different peripherals to retain their state after a watchdog or software reset.

#### RSTSTA Register

Name:	RSTSTA
Address:	0xFFFF0230
Default Value:	0x01
Access:	Read only

**Table 60. RSTSTA MMR Bit Descriptions**

Bit	Description
[7:3]	Reserved.
2	Software reset. Set by the user to force a software reset. Cleared by setting the corresponding bit in RSTCLR.
1	Watchdog timeout. Set automatically when a watchdog timeout occurs. Cleared by setting the corresponding bit in RSTCLR.
0	Power-on reset. Set automatically when a power-on reset occurs. Cleared by setting the corresponding bit in RSTCLR.

#### RSTCLR Register

Name:	RSTCLR
Address:	0xFFFF0234
Default Value:	0x00
Access:	Write only

Note that to clear the RSTSTA register, users must write the Value 0x07 to the RSTCLR register.

#### RSTCFG Register

Name:	RSTCFG
Address:	0xFFFF024C
Default Value:	0x05
Access:	Read/write

**Table 61. RSTCFG MMR Bit Descriptions**

Bit	Description
[7:3]	Reserved. Always set to 0.
2	This bit is set to 1 to configure the DAC outputs to retain their state after a watchdog or software reset. This bit is cleared for the DAC pins and registers to return to their default state.
1	Reserved. Always set to 0.
0	This bit is set to 1 to configure the GPIO pins to retain their state after a watchdog or software reset. This bit is cleared for the GPIO pins and registers to return to their default state.

The RSTCFG write sequence is as follows:

1. Write Code 0x76 to Register RSTKEY1.
2. Write user value to Register RSTCFG.
3. Write Code 0xB1 to Register RSTKEY2.

***RSTKEY0 Register***

Name: RSTKEY0  
Address: 0xFFFF0248  
Default Value: N/A  
Access: Write only

***RSTKEY1 Register***

Name: RSTKEY1  
Address: 0xFFFF0250  
Default Value: N/A  
Access: Write only

## OTHER ANALOG PERIPHERALS

### DAC

The ADuC7124/ADuC7126 incorporate two, or four, 12-bit voltage output DACs on chip, depending on the model. Each DAC has a rail-to-rail voltage output buffer capable of driving 5 k $\Omega$ /100 pF.

Each DAC has three selectable ranges: 0 V to  $V_{REF}$  (internal band gap 2.5 V reference), 0 V to  $DAC_{REF}$ , and 0 V to  $AV_{DD}$ .  $DAC_{REF}$  is equivalent to an external reference for the DAC. The signal range is 0 V to  $AV_{DD}$ .

#### MMRs Interface

Each DAC is independently configurable through a control register and a data register. These two registers are identical for the four DACs. Only DAC0CON (see Table 63) and DAC0DAT (see Table 65) are described in detail in this section.

Table 62. DACxCON Registers

Name	Address	Default Value	Access
DAC0CON	0xFFFF0600	0x00	R/W
DAC1CON	0xFFFF0608	0x00	R/W
DAC2CON	0xFFFF0610	0x00	R/W
DAC3CON	0xFFFF0618	0x00	R/W

Table 63. DAC0CON MMR Bit Descriptions

Bit	Value	Name	Description
[7:6]			Reserved.
5		DACCLK	DAC update rate. Set by the user to update the DAC using Timer1. Cleared by the user to update the DAC using HCLK (core clock).
4		DACCLR	DAC clear bit. Set by the user to enable normal DAC operation. Cleared by the user to reset the data register of the DAC to 0.
3			Reserved. This bit should be left at 0.
2			Reserved. This bit should be left at 0.
[1:0]			DAC range bits.
	00		Power-down mode. The DAC output is in tristate.
	01		0 V to $DAC_{REF}$ range.
	10		0 V to $V_{REF}$ (2.5 V) range.
	11		0 V to $AV_{DD}$ range.

Table 64. DACxDAT Registers

Name	Address	Default Value	Access
DAC0DAT	0xFFFF0604	0x00000000	R/W
DAC1DAT	0xFFFF060C	0x00000000	R/W
DAC2DAT	0xFFFF0614	0x00000000	R/W
DAC3DAT	0xFFFF061C	0x00000000	R/W

Table 65. DAC0DAT MMR Bit Descriptions

Bit	Description
[31:28]	Reserved.
[27:16]	12-bit data for DAC0.
[15:0]	Reserved.

#### Using the DACs

The on-chip DAC architecture consists of a DAC resistor string followed by an output buffer amplifier. The functional equivalent is shown in Figure 41.

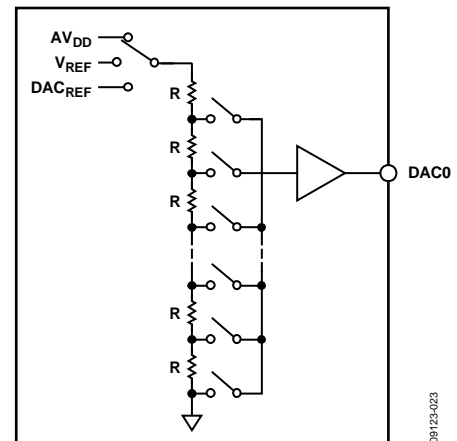

Figure 41. DAC Structure

As illustrated in Figure 41, the reference source for each DAC is user selectable in software. It can be either  $AV_{DD}$ ,  $V_{REF}$ , or  $DAC_{REF}$ . In 0 V-to- $AV_{DD}$  mode, the DAC output transfer function spans from 0 V to the voltage at the  $AV_{DD}$  pin. In 0 V-to- $DAC_{REF}$  mode, the DAC output transfer function spans from 0 V to the voltage at the  $DAC_{REF}$  pin. In 0 V-to- $V_{REF}$  mode, the DAC output transfer function spans from 0 V to the internal 2.5 V reference,  $V_{REF}$ .

The DAC output buffer amplifier features a true, rail-to-rail output stage implementation. This means that, when unloaded, each output is capable of swinging to within less than 5 mV of both  $AV_{DD}$  and ground. Moreover, the DAC linearity specification (when driving a 5 k $\Omega$  resistive load to ground) is guaranteed through the full transfer function except the 0 to 100 codes, and, in 0 V-to- $AV_{DD}$  mode only, Code 3995 to Code 4095.

Linearity degradation near ground and  $V_{DD}$  is caused by saturation of the output amplifier, and a general representation of its effects (neglecting offset and gain error) is illustrated in Figure 42. The dotted line in Figure 42 indicates the ideal transfer function, and the solid line represents what the transfer function may look like with endpoint nonlinearities due to saturation of the output amplifier. Note that Figure 42 represents a transfer function in 0 V-to- $AV_{DD}$  mode only. In 0 V-to- $V_{REF}$  or 0 V-to- $DAC_{REF}$  mode (with  $V_{REF} < AV_{DD}$  or  $DAC_{REF} < AV_{DD}$ ), the lower nonlinearity is similar. However, the upper portion of the transfer function follows the ideal line right to the end ( $V_{REF}$  in this case, not  $AV_{DD}$ ), showing no signs of endpoint linearity errors.

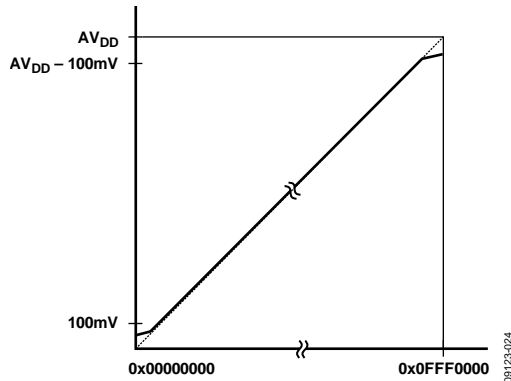

Figure 42. Endpoint Nonlinearities Due to Amplifier Saturation

The endpoint nonlinearities conceptually illustrated in Figure 42 becomes worse as a function of output loading. Most of the ADuC7124/ADuC7126 data sheet specifications assume a 5 k $\Omega$  resistive load to ground at the DAC output. As the output is forced to source or sink more current, the nonlinear regions at the top or bottom (respectively) of Figure 42 become larger. With larger current demands, this can significantly limit output voltage swing.

### References to ADC and the DACs

The ADC and DACs can be configured to use the internal  $V_{REF}$  or an external reference as a reference source. The internal  $V_{REF}$  must work with an external 0.47  $\mu$ F capacitor.

Table 66. Reference Source Selection for the ADC and DACs

REFCON[0]	DACxCON[1:0]	Description
0	00	ADC works with an external reference. DACs are powered down.
0	01	ADC works with an external reference. DAC works with $DAC_{REF}$ .
0	10	Reserved.
0	11	ADC works with an external reference. DACs work with internal $AV_{DD}$ .
1	00	ADC works with an internal $V_{REF}$ . DACs are powered down.
1	01	ADC works with an external reference. DACs work with $DAC_{REF}$ .
1	10	ADC and DACs work with an internal $V_{REF}$ .
1	11	ADC works with an internal $V_{REF}$ . DACs work with an internal $AV_{DD}$ .

Note that if REFCON[1] = 1, the internal  $V_{REF}$  powers down and the ADC cannot use the internal  $V_{REF}$ .

### Configuring DAC Buffers in Op Amp Mode

In op amp mode, the DAC output buffers are used as an op amp with the DAC itself disabled.

If DACBCFG Bit 0 is set, ADC0 is the positive input to the op amp, ADC1 is the negative input, and DAC0 is the output. In this mode, the DAC should be powered down by clearing Bit 0 and Bit 1 of DAC0CON.

If DACBCFG Bit 1 is set, ADC2 is the positive input to the op amp, ADC3 is the negative input, and DAC1 is the output. In this mode, the DAC should be powered down by clearing Bit 0 and Bit 1 of DAC1CON.

If DACBCFG Bit 2 is set, ADC4 is the positive input to the op amp, ADC5 is the negative input, and DAC2 is the output. In this mode, the DAC should be powered down by clearing Bit 0 and Bit 1 of DAC2CON.

If DACBCFG Bit 3 is set, ADC8 is the positive input to the op amp, ADC9 is the negative input, and DAC3 is the output. In this mode, the DAC should be powered down by clearing Bit 0 and Bit 1 of DAC3CON.

### DACBCFG Register

Name:	DACBCFG
Address:	0xFFFF0654
Default Value:	0x00
Access:	Read/write

Table 67. DACBCFG MMR Bit Descriptions

Bit	Description
[7:4]	Reserved. Always set to 0.
3	Set this bit to 1 to configure the DAC3 output buffer in op amp mode. Clear this bit for the DAC buffer to operate as normal.
2	Set this bit to 1 to configure the DAC2 output buffer in op amp mode. Clear this bit for the DAC buffer to operate as normal.
1	Set this bit to 1 to configure the DAC1 output buffer in op amp mode. Clear this bit for the DAC buffer to operate as normal.
0	Set this bit to 1 to configure the DAC0 output buffer in op amp mode. Clear this bit for the DAC buffer to operate as normal.

The DACBCFG write sequence is as follows:

1. Write Code 0x9A to Register DACBKEY1.
2. Write user value to Register DACBCFG.
3. Write Code 0x0C to Register DACBKEY2.

**DACBKEY1 Register**

Name: DACBKEY1  
 Address: 0xFFFF0650  
 Default Value: 0x0000  
 Access: Write

**DACBKEY2 Register**

Name: DACBKEY2  
 Address: 0xFFFF0658  
 Default Value: 0x0000  
 Access: Write

**POWER SUPPLY MONITOR**

The power supply monitor regulates the IOV<sub>DD</sub> supply on the ADuC7124/ADuC7126. It indicates when the IOV<sub>DD</sub> supply pin drops below one of two supply trip points. The monitor function is controlled via the PSMCON register. If enabled in the IRQEN or FIQEN register, the monitor interrupts the core using the PSMI bit in the PSMCON MMR. This bit is immediately cleared when CMP goes high.

This monitor function allows the user to save working registers to avoid possible data loss due to low supply or brown-out conditions. It also ensures that normal code execution does not resume until a safe supply level is established.

**PSMCON Register**

Name: PSMCON  
 Address: 0xFFFF0440  
 Default Value: 0x0008  
 Access: Read/write

Table 68. PSMCON MMR Bit Descriptions

Bit	Name	Description
3	CMP	Comparator bit. This is a read-only bit that directly reflects the state of the comparator. Read 1 indicates that the IOV <sub>DD</sub> supply is above its selected trip point or that the PSM is in power-down mode. Read 0 indicates that the IOV <sub>DD</sub> supply is below its selected trip point. This bit should be set before leaving the interrupt service routine.
2	TP	Trip point selection bits. 0 = 2.79 V, 1 = 3.07 V.
1	PSMEN	Power supply monitor enable bit. Set to 1 to enable the power supply monitor circuit. Clear to 0 to disable the power supply monitor circuit.
0	PSMI	Power supply monitor interrupt bit. This bit is set high by the MicroConverter when CMP goes low, indicating low I/O supply. The PSMI bit can be used to interrupt the processor. When CMP returns high, the PSMI bit can be cleared by writing a 1 to this location. A 0 write has no effect. There is no timeout delay; PSMI can be immediately cleared when CMP goes high.

**COMPARATOR**

The ADuC7124/ADuC7126 integrate a voltage comparator. The positive input is multiplexed with ADC2, and the negative input has two options: ADC3 or DAC0. The output of the comparator can be configured to generate a system interrupt, be routed directly to the programmable logic array, start an ADC conversion, or be on an external pin, CMP<sub>OUT</sub>, as shown in Figure 43.

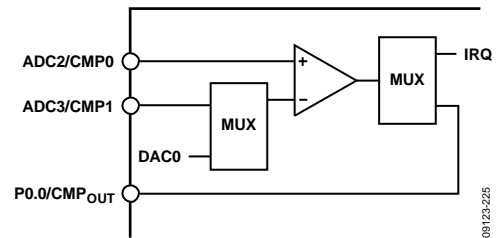

Figure 43. Comparator

**Hysteresis**

Figure 44 shows how the input offset voltage and hysteresis terms are defined. Input offset voltage (V<sub>OS</sub>) is the difference between the center of the hysteresis range and the ground level. This can either be positive or negative. The hysteresis voltage (V<sub>H</sub>) is ½ the width of the hysteresis range.

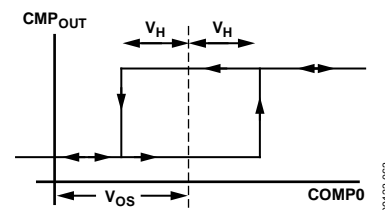

Figure 44. Comparator Hysteresis Transfer Function

**Comparator Interface**

The comparator interface consists of a 16-bit MMR, CMPCON, which is described in Table 69.

**CMPCON Register**

Name: CMPCON  
 Address: 0xFFFF0444  
 Default Value: 0x0000  
 Access: Read/write

**Table 69. CMPCON MMR Bit Descriptions**

Bit	Value	Name	Description
[15:11]			Reserved.
10		CMPEN	Comparator enable bit. Set by the user to enable the comparator. Cleared by the user to disable the comparator.
[9:8]		CMPIN	Comparator negative input select bits.
	00		AV <sub>DD</sub> /2.
	01		ADC3 input.
	10		DAC0 output.
[7:6]		CMPOC	Comparator output configuration bits.
	00		Reserved.
	01		Reserved.
	10		Output on CMP <sub>OUT</sub> .
5		CMPOL	Comparator output logic state bit. When low, the comparator output is high if the positive input (CMP0) is above the negative input (CMP1). When high, the comparator output is high if the positive input is below the negative input.
	00		Reserved.
	01		Reserved.
	11		IRQ.
[4:3]		CMPRES	Response time.
	00		5 μs response time typical for large signals (2.5 V differential). 17 μs response time typical for small signals (0.65 mV differential).
	11		4 μs typical.
	01/10		Reserved.
2		CMPHYST	Comparator hysteresis bit. Set by user to have a hysteresis of about 7.5 mV. Cleared by user to have no hysteresis.

Bit	Value	Name	Description
1		CMPORI	Comparator output rising edge interrupt. Set automatically when a rising edge occurs on the monitored voltage (CMP0). Cleared by user by writing a 1 to this bit.
0		CMPOFI	Comparator output falling edge interrupt. Set automatically when a falling edge occurs on the monitored voltage (CMP0). Cleared by user by writing a 1 to this bit.

**OSCILLATOR AND PLL—POWER CONTROL**

**Clocking System**

The ADuC7124/ADuC7126 integrate a 32.768 kHz ± 3% oscillator, a clock divider, and a PLL. The PLL locks onto a multiple (1275) of the internal oscillator or an external 32.768 kHz crystal to provide a stable 41.78 MHz clock (UCLK) for the system. To allow power saving, the core can operate at this frequency or at binary submultiples of it. The actual core operating frequency, UCLK/2<sup>CD</sup>, is referred to as HCLK. The default core clock is the PLL clock divided by 8 (CD = 3) or 5.22 MHz. The core clock frequency can also come from an external clock on the ECLK pin as shown in Figure 45. The core clock can be output on ECLK when using an internal oscillator or external crystal.

Note that, when the ECLK pin is used to output the core clock, the output signal is not buffered and is not suitable for use as a clock source to an external device without an external buffer.

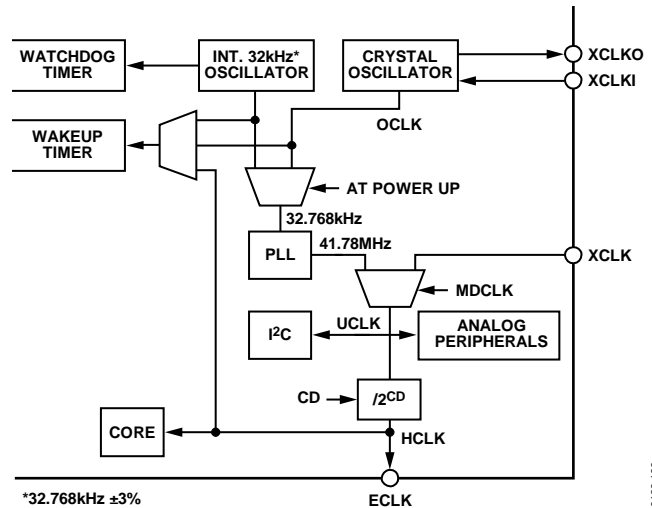

Figure 45. Clocking System

The selection of the clock source is in the PLLCON register. By default, the part uses the internal oscillator feeding the PLL.

**External Crystal Selection**

To switch to an external crystal, the user must follow this procedure:

1. Enable the Timer2 interrupt and configure it for a timeout period of >120  $\mu$ s.
2. Follow the write sequence to the PLLCON register, setting the MDCLK bits to 01 and clearing the OSEL bit.
3. Force the part into nap mode by following the correct write sequence to the POWCON0 register.
4. When the part is interrupted from nap mode by the Timer2 interrupt source, the clock source has switched to the external clock.

Example source code:

```
T2LD = 5;
T2CON = 0x480;
IRQEN = 0x10;
//enable T2 interrupt

PLLKEY1 = 0xAA;
PLLCON = 0x01;
PLLKEY2 = 0x55;

POWKEY1 = 0x01;
POWCON0 = 0x27; // Set core into nap mode
POWKEY2 = 0xF4;
```

In noisy environments, noise can couple to the external crystal pins, and PLL may lose lock momentarily. A PLL interrupt is provided in the interrupt controller. The core clock is immediately halted, and this interrupt is serviced only when the lock is restored.

In case of crystal loss, the watchdog timer should be used. During initialization, a test on the RSTSTA can determine if the reset came from the watchdog timer.

**External Clock Selection**

To switch to an external clock on P0.7, configure P0.7 in Mode 1. The external clock can be up to 41.78 MHz, providing the tolerance is 1%.

Example source code:

```
T2LD = 5;
T2CON = 0x480;

IRQEN = 0x10;
//enable T2 interrupt

PLLKEY1 = 0xAA;
PLLCON = 0x03; //Select external clock
PLLKEY2 = 0x55;

POWKEY1 = 0x01;
POWCON0 = 0x27; //
Set core into nap mode
POWKEY2 = 0xF4;
```

**Power Control System**

A choice of operating modes is available on the [ADuC7124/ADuC7126](#). Table 70 describes what part is powered on in the different modes and indicates the power-up time.

Table 71 gives some typical values of the total current consumption (analog + digital supply currents) in the different modes, depending on the clock divider bits. The AC, DAC, I<sup>2</sup>C, and SPI are turned off.

**Table 70. Operating Modes**

Mode	Core	Peripherals	PLL	XTAL/T2/T3	IRQ0 to IRQ3	Start-Up/Power-On Time
Active	On	On	On	On	On	66 ms at CD = 0
Pause		On	On	On	On	2.6 $\mu$ s at CD = 0; 247 $\mu$ s at CD = 7
Nap			On	On	On	2.6 $\mu$ s at CD = 0; 247 $\mu$ s at CD = 7
Sleep				On	On	1.58 ms
Stop					On	1.7 ms

**Table 71. Typical Current Consumption at 25°C in mA, V<sub>DD</sub> = 3.3 V**

Mode	CD = 0	CD = 1	CD = 2	CD = 3	CD = 4	CD = 5	CD = 6	CD = 7
Active	33.3	23.1	15.4	11.6	9.7	8.8	8.3	8.1
Pause	20.6	12.7	8.8	6.8	5.8	5.3	5.1	4.9
Nap	4.6	4.6	4.6	4.6	4.6	4.6	4.6	4.6
Sleep	0.2	0.2	0.2	0.2	0.2	0.2	0.2	0.2
Stop	0.2	0.2	0.2	0.2	0.2	0.2	0.2	0.2

**MMRs and Keys**

The operating mode, clocking mode, and programmable clock divider are controlled via three MMRs, PLLCON (see Table 73), and POWCONx. PLLCON controls the operating mode of the clock system, POWCON0 controls the core clock frequency and the power-down mode, and POWCON1 controls the clock frequency to I<sup>2</sup>C and SPI.

**Table 72. PLLKEYx Registers**

Name	Address	Default Value	Access
PLLKEY1	0xFFFF0410	0x0000	W
PLLKEY2	0xFFFF0418	0x0000	W

**PLLCON Register**

Name: PLLCON  
 Address: 0xFFFF0414  
 Default Value: 0x21  
 Access: Read/write

**Table 73. PLLCON MMR Bit Descriptions**

Bit	Value	Name	Description
[7:6]			Reserved.
5		OSEL	32 kHz PLL input selection. Set by the user to select the internal 32 kHz oscillator. Set by default. Cleared by the user to select the external 32 kHz crystal.
[4:2]			Reserved.
[1:0]		MDCLK	Clocking modes.
	00		Reserved.
	01		PLL. Default configuration.
	10		Reserved.
	11		External clock on the P0.7 Pin.

To prevent accidental programming, a certain sequence must be followed to write to the PLLCON register. The PLLCON write sequence is as follows:

1. Write Code 0xAA to Register PLLKEY1.
2. Write user value to Register PLLCON.
3. Write Code 0x55 to Register PLLKEY2.

**Table 74. POWKEYx Registers**

Name	Address	Default Value	Access
POWKEY1	0xFFFF0404	0x0000	W
POWKEY2	0xFFFF040C	0x0000	W

POWKEY1 and POWKEY2 are used to prevent accidental programming to POWCON0.

**POWCON0 Register**

Name: POWCON0  
 Address: 0xFFFF0408  
 Default Value: 0x0003  
 Access: Read/write

**Table 75. POWCON0 MMR Bit Descriptions**

Bit	Value	Name	Description
7			Reserved.
[6:4]		PC	Operating modes.
	000		Active mode.
	001		Pause mode.
	010		Nap mode.
	011		Sleep mode. IRQ0 to IRQ3 and Timer2 can wake up the part.
	100		Stop mode. IRQ0 to IRQ3 can wake up the part.
	Others		Reserved.
3			Reserved.
[2:0]		CD	CPU clock divider bits.
	000		41.78 MHz.
	001		20.89 MHz.
	010		10.44 MHz.
	011		5.22 MHz.
	100		2.61 MHz.
	101		1.31 MHz.
	110		653 kHz.
	111		326 kHz.

To prevent accidental programming, a certain sequence must be followed to write to the POWCONx register. The POWCON0 write sequence is as follows:

1. Write Code 0x01 to Register POWKEY1.
2. Write a user value to Register POWCON0.
3. Write Code 0xF4 to Register POWKEY2.

**Table 76. POWKEYx Registers**

Name	Address	Default Value	Access
POWKEY3	0xFFFF0434	0x0000	W
POWKEY4	0xFFFF043C	0x0000	W

POWKEY3 and POWKEY4 are used to prevent accidental programming to POWCON1.

**POWCON1 Register**

Name: POWCON1  
 Address: 0xFFFF0438  
 Default Value: 0x124  
 Access: Read/write

Table 77. POWCON1 MMR Bit Descriptions<sup>1</sup>

Bit	Value	Name	Description
[15:12]			Reserved.
11	1	PWMPO	Clearing this bit powers down the PWM. Always clear to 00.
[10:9]	00	PWMCLKDIV	
8		SPIPO	Clearing this bit powers down the SPI.
[7:6]		SPICLKDIV	SPI block driving clock divider bits.
	00		41.78 MHz.
	01		20.89 MHz.
	10		10.44 MHz.
	11		5.22 MHz.
5		I2C1PO	Clearing this bit powers down I2C1.
[4:3]		I2C1CLKDIV	I2C0 block driving clock divider bits.
	00		41.78 MHz.
	01		10.44 MHz.
	10		5.22 MHz.
	11		1.31 MHz.
2		I2C0PO	Clearing this bit powers down I2C0.
[1:0]		I2C0CLKDIV	I2C1 block driving clock divider bits.
	00		41.78 MHz.
	01		10.44 MHz.
	10		5.22 MHz.
	11		1.31 MHz.

<sup>1</sup> Divided clock for SPI/I2C0/I2C1 must be greater than or equal to the CPU clock as selected by POWCON0 [2:0].

The POWCON1 write sequence is as follows:

1. Write Code 0x76 to Register POWKEY3.
2. Write user value to Register POWCON1.
3. Write Code 0xB1 to Register POWKEY4.

## DIGITAL PERIPHERAL

### GENERAL-PURPOSE INPUT/OUTPUT

The ADuC7124/ADuC7126 provide 40 general-purpose, bidirectional I/O (GPIO) pins. All I/O pins are 5 V tolerant, meaning the GPIOs support an input voltage of 5 V.

In general, many of the GPIO pins have multiple functions (see the Pin Configurations and Function Descriptions section for pin function definitions). By default, the GPIO pins are configured in GPIO mode.

All GPIO pins have an internal pull-up resistor (of about 100 k $\Omega$ ), and their drive capability is 1.6 mA. Note that a maximum of 20 GPIOs can drive 1.6 mA at the same time. Using the GPxPAR registers, it is possible to enable/disable the pull-up resistors for the following ports: P0.0, P0.4, P0.5, P0.6, P0.7, and the eight GPIOs of P1.

The 40 GPIOs are grouped in five ports, Port 0 to Port 4 (Port x). Each port is controlled by four or five MMRs.

Note that the kernel changes P0.6 from its default configuration at reset (MRST) to GPIO mode. If MRST is used for external circuitry, an external pull-up resistor should be used to ensure that the level on P0.6 does not drop when the kernel switches mode. Otherwise, P0.6 goes low for the reset period. For example, if MRST is required for power-down, it can be reconfigured in GP0CON MMR.

The input level of any GPIO can be read at any time in the GPxDAT MMR, even when the pin is configured in a mode other than GPIO. The PLA input is always active.

When the ADuC7124/ADuC7126 enter a power-saving mode, the GPIO pins retain their state. Also, note that, by setting RSTCFG Bit 0, the GPIO pins can retain their state during a watchdog or software reset.

Table 78. GPIO Pin Function Descriptions

Port	Pin	Configuration			
		00	01	10	11
0	BM/P0.0	GPIO	CMP	MS0	PLAI[7]
	TDI/P0.1 <sup>1</sup>	GPIO/JTAG	PWM4	BLE <sup>4</sup>	
	TDO/P0.2 <sup>1</sup>	GPIO/JTAG	PWM5	BHE <sup>4</sup>	
	TRST/P0.3 <sup>1</sup>	GPIO/JTAG	TRST	A16 <sup>4</sup>	ADC <sub>BUSY</sub>
	P0.4	GPIO/IRQ0	PWM <sub>TRIP</sub>	MS1 <sup>4</sup>	PLAO[1]
	P0.5	GPIO/IRQ1	ADC <sub>BUSY</sub>	MS2 <sup>4</sup>	PLAO[2]
	P0.6	GPIO	MRST	MS3 <sup>4</sup>	PLAO[3]
	P0.7	GPIO	ECLK/XCLK <sup>2</sup>	SIN0	PLAO[4]
1	P1.0	GPIO/T1	SIN0	SCL0 <sup>3</sup>	PLAI[0]
	P1.1	GPIO	SOUT0	SDA0 <sup>3</sup>	PLAI[1]
	P1.2	GPIO	RTS <sup>3</sup>	SCL1 <sup>3</sup>	PLAI[2]
	P1.3	GPIO	CTS <sup>3</sup>	SDA1 <sup>3</sup>	PLAI[3]
	P1.4	GPIO/IRQ2	RI <sup>3</sup>	SCLK <sup>3</sup>	PLAI[4]
	P1.5	GPIO/IRQ3	DCD <sup>3</sup>	MISO <sup>3</sup>	PLAI[5]
	P1.6	GPIO	DSR <sup>3</sup>	MOSI <sup>3</sup>	PLAI[6]
	P1.7	GPIO	DTR <sup>3</sup>	$\overline{CS}$ <sup>3</sup>	PLAO[0]
2	P2.0	GPIO	CONV <sub>START</sub>	SOUT0	PLAO[5]
	P2.1	GPIO	PWM0	$\overline{WS}$ <sup>4</sup>	PLAO[6]
	P2.2	GPIO	PWM1	$\overline{RS}$ <sup>4</sup>	PLAO[7]
	P2.3	GPIO		AE <sup>4</sup>	SIN1
	P2.4	GPIO	PWM0	MS0 <sup>4</sup>	SOUT1
	P2.5	GPIO	PWM1	MS1 <sup>4</sup>	
	P2.6	GPIO	PWM2	MS2 <sup>4</sup>	
	P2.7	GPIO	PWM3	MS3 <sup>4</sup>	
3	P3.0	GPIO	PWM0	AD0 <sup>4</sup>	PLAI[8]
	P3.1	GPIO	PWM1	AD1 <sup>4</sup>	PLAI[9]
	P3.2	GPIO	PWM2	AD2 <sup>4</sup>	PLAI[10]
	P3.3	GPIO	PWM3	AD3 <sup>4</sup>	PLAI[11]
	P3.4	GPIO	PWM4	AD4 <sup>4</sup>	PLAI[12]
	P3.5	GPIO	PWM5	AD5 <sup>4</sup>	PLAI[13]
	P3.6	GPIO	PWM <sub>TRIP</sub>	AD6 <sup>4</sup>	PLAI[14]
	P3.7	GPIO	PWM <sub>SYNC</sub>	AD7 <sup>4</sup>	PLAI[15]
4	P4.0	GPIO	SIN1	AD8 <sup>4</sup>	PLAO[8]
	P4.1	GPIO	SOUT1	AD9 <sup>4</sup>	PLAO[9]
	P4.2	GPIO		AD10 <sup>4</sup>	PLAO[10]
	P4.3	GPIO		AD11 <sup>4</sup>	PLAO[11]
	P4.4	GPIO		AD12 <sup>4</sup>	PLAO[12]
	P4.5	GPIO/RTCK <sup>5</sup>		AD13 <sup>4</sup>	PLAO[13]
	P4.6	GPIO		AD14 <sup>4</sup>	PLAO[14]
	P4.7	GPIO		AD15 <sup>4</sup>	PLAO[15]

<sup>1</sup> These pins should not be used by user code.

<sup>2</sup> When configured in Mode 1, P0.7 is ECLK by default, or core clock output. To configure it as a clock input, the MDCLK bits in PLLCON must be set to 11.

<sup>3</sup> See Table 90 for SPM configurations.

<sup>4</sup> External Memory Interface signals are only available on ADuC7126.

<sup>5</sup> In debug mode, the RTCK mode cannot be disabled.

Table 79. GPxCON Registers

Name	Address	Default Value	Access
GP0CON	0xFFFFF400	0x00000000	R/W
GP1CON	0xFFFFF404	0x00000000	R/W
GP2CON	0xFFFFF408	0x00000000	R/W
GP3CON	0xFFFFF40C	0x00000000	R/W
GP4CON	0xFFFFF410	0x00000000	R/W

GPxCON are the Port x control registers that select the function of each pin of Port x, as described in Table 80.

Table 80. GPxCON MMR Bit Descriptions

Bit	Description
[31:30]	Reserved.
[29:28]	Select function of Px.7 pin.
[27:26]	Reserved.
[25:24]	Select function of Px.6 pin.
[23:22]	Reserved.
[21:20]	Select function of Px.5 pin.
[19:18]	Reserved.
[17:16]	Select function of Px.4 pin.
[15:14]	Reserved.
[13:12]	Select function of Px.3 pin.
[11:10]	Reserved.
[9:8]	Select function of Px.2 pin.
[7:6]	Reserved.
[5:4]	Select function of Px.1 pin.
[3:2]	Reserved.
[1:0]	Select function of Px.0 pin.

Table 81. GPxPAR Registers

Name	Address	Default Value	Access
GP0PAR	0xFFFFF42C	0x20000000	R/W
GP1PAR	0xFFFFF43C	0x00000000	R/W
GP2PAR	0xFFFFF44C	0x000000FF	R/W
GP3PAR	0xFFFFF45C	0x00222222	R/W
GP4PAR	0xFFFFF46C	0x00000000	R/W

The GPxPAR registers program the parameters for Port 0, Port 1, Port 2, Port 3, and Port 4. Note that the GPxDAT MMR must always be written after changing the GPxPAR MMR.

Table 82. GPxPAR MMR Bit Descriptions

Bit	Description
31	Reserved.
[30:29]	Drive strength Px.7.
28	Pull-up disable Px.7.
27	Reserved.
[26:25]	Drive strength Px.6.
24	Pull-up disable Px.6.
23	Reserved.
[22:21]	Drive strength Px.5.
20	Pull-up disable Px.5.
19	Reserved.
[18:17]	Drive strength Px.4.

Bit	Description
16	Pull-up disable Px.4.
15	Reserved.
[14:13]	Drive strength Px.3.
12	Pull-up disable Px.3.
11	Reserved.
[10:9]	Drive strength Px.2.
8	Pull-up disable Px.2.
7	Reserved.
[6:5]	Drive strength Px.1.
4	Pull-up disable Px.1.
3	Reserved.
[2:1]	Drive strength Px.0.
0	Pull-up disable Px.0.

Table 83. GPIO Drive Strength Control Bits Descriptions

Control Bits Value	Description
00	Medium drive strength.
01	Low drive strength.
1x	High drive strength.

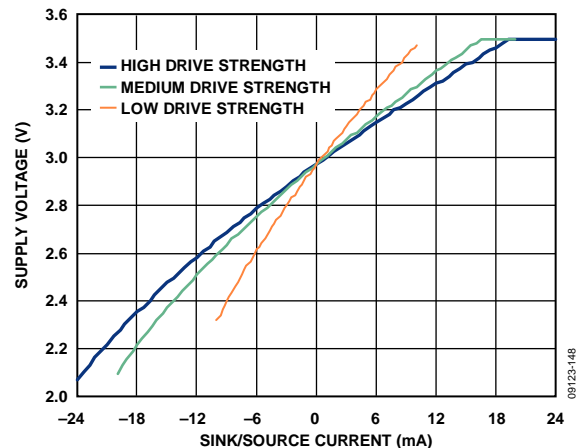

Figure 46. Programmable Strength for High Level

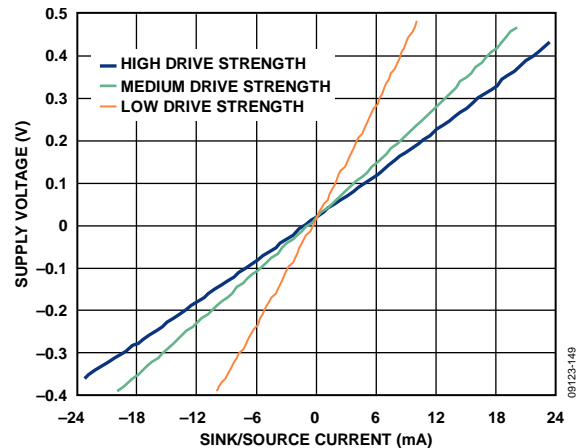

Figure 47. Programmable Strength for Low Level

The drive strength bits can be written only once after reset. Additional writing to related bits has no effect on drive strength. The GPIO drive strength and pull-up disable are not always adjustable for GPIO port. Some control bits cannot be changed. See Table 78 for details.

**Table 84. GPxDAT Registers**

Name	Address	Default Value	Access
GP0DAT	0xFFFFF420	0x000000XX	R/W
GP1DAT	0xFFFFF430	0x000000XX	R/W
GP2DAT	0xFFFFF440	0x000000XX	R/W
GP3DAT	0xFFFFF450	0x000000XX	R/W
GP4DAT	0xFFFFF460	0x000000XX	R/W

The GPxDAT are Port x configuration and data registers. They configure the direction of the GPIO pins of Port x, set the output value for the pins configured as output, and store the input value of the pins configured as input.

**Table 85. GPxDAT MMR Bit Descriptions**

Bit	Description
[31:24]	Direction of the data. Set to 1 by the user to configure the GPIO pin as an output. Cleared to 0 by the user to configure the GPIO pin as an input.
[23:16]	Port x data output.
[15:8]	Reflect the state of Port x pins at reset (read only).
[7:0]	Port x data input (read only).

**Table 86. GPxSET Registers**

Name	Address	Default Value	Access
GP0SET	0xFFFFF424	0x000000XX	W
GP1SET	0xFFFFF434	0x000000XX	W
GP2SET	0xFFFFF444	0x000000XX	W
GP3SET	0xFFFFF454	0x000000XX	W
GP4SET	0xFFFFF464	0x000000XX	W

The GPxSET are data set Port x registers.

**Table 87. GPxSET MMR Bit Descriptions**

Bit	Description
[31:24]	Reserved.
[23:16]	Data Port x set bit. Set to 1 by the user to set a bit on Port x; also sets the corresponding bit in the GPxDAT MMR. Cleared to 0 by the user; does not affect the data output.
[15:0]	Reserved.

**Table 88. GPxCLR Registers**

Name	Address	Default Value	Access
GP0CLR	0xFFFFF428	0x000000XX	W
GP1CLR	0xFFFFF438	0x000000XX	W
GP2CLR	0xFFFFF448	0x000000XX	W
GP3CLR	0xFFFFF458	0x000000XX	W
GP4CLR	0xFFFFF468	0x000000XX	W

The GPxCLR are data clear Port x registers.

**Table 89. GPxCLR MMR Bit Descriptions**

Bit	Description
[31:24]	Reserved.
[23:16]	Data Port x clear bit. Set to 1 by the user to clear a bit on Port x; also clears the corresponding bit in the GPxDAT MMR. Cleared to 0 by the user; does not affect the data out.
[15:0]	Reserved.

## SERIAL PORT MUX

The serial port mux multiplexes the serial port peripherals (an SPI, UART, and two I<sup>2</sup>Cs) and the programmable logic array (PLA) to a set of 10 GPIO pins. Each pin must be configured to one of its specific I/O functions as described in Table 90.

**Table 90. SPM Configuration**

SPM	GPIO (00)	UART (01)	UART/I <sup>2</sup> C/SPI (10)	PLA (11)
SPM0	P1.0	SIN0	I2C0SCL	PLAI[0]
SPM1	P1.1	SOUT0	I2C0SDA	PLAI[1]
SPM2	P1.2	RTS	I2C1SCL	PLAI[2]
SPM3	P1.3	CTS	I2C1SDA	PLAI[3]
SPM4	P1.4	RI	SCLK	PLAI[4]
SPM5	P1.5	DCD	MISO	PLAI[5]
SPM6	P1.6	DSR	MOSI	PLAI[6]
SPM7	P1.7	DTR	$\overline{CS}$	PLAO[0]
SPM8	P0.7	ECLK/XCLK	SIN0	PLAO[4]
SPM9	P2.0	CONV <sub>START</sub>	SOUT0	PLAO[5]
SPM10	P4.0	SIN1	AD8	PLAO[8]
SPM11	P4.1	SOUT1	AD9	PLAO[9]
SPM12	P2.3	N/A	AE	SIN1
SPM13	P2.4	PWM0	MSO	SOUT1

Table 90 also details the mode for each of the SPMUX pins. This configuration has to be done via the GP0CON, GP1CON, and GP2CON MMRs. By default, these 10 pins are configured as GPIOs.

## UART SERIAL INTERFACE

The UART peripheral is a full-duplex, universal, asynchronous receiver/transmitter. The UART performs serial-to-parallel conversions on data characters received from a peripheral device and parallel-to-serial conversions on data characters received from the CPU. The ADuC7124/ADuC7126 has been equipped with two industry standard 16,450 type UARTs (UART0 and UART1). Each UART features a fractional divider that facilitates high accuracy baud rate generation and is equipped with a 16-byte FIFO for the transmitter and a 16-byte FIFO for the receiver. Both UARTs can be configured as FIFO mode and non-FIFO mode.

The serial communication adopts an asynchronous protocol, which supports various word lengths, stop bits, and parity generation options selectable in the configuration register.

**Baud Rate Generation**

There are two ways of generating the UART baud rate, using normal 450 UART baud rate generation and using the fractional divider.

**Normal 450 UART Baud Rate Generation**

The baud rate is a divided version of the core clock using the value in the COMxDIV0 and COMxDIV1 MMRs (16-bit value, DL).

$$Baud\ Rate = \frac{41.78\text{MHz}}{2^{CD} \times 16 \times 2 \times DL}$$

Table 91 gives some common baud rate values.

**Table 91. Baud Rate Using the Normal Baud Rate Generator**

Baud Rate	CD	DL	Actual Baud Rate	% Error
9600	0	0x88	9600	0
19,200	0	0x44	19,200	0
115,200	0	0x0B	118,691	3
9600	3	0x11	9600	0
19,200	3	0x08	20,400	6.25
115,200	3	0x01	163,200	41.67

**The Fractional Divider**

The fractional divider, combined with the normal baud rate generator, produces a wider range of more accurate baud rates.

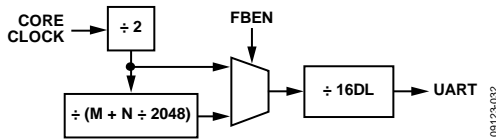

Figure 48. Baud Rate Generation Options

Calculation of the baud rate using fractional divider is as follows:

$$Baud\ Rate = \frac{41.78\text{MHz}}{2^{CD} \times 16 \times DL \times 2 \times \left( M + \frac{N}{2048} \right)}$$

$$M + \frac{N}{2048} = \frac{41.78\text{MHz}}{Baud\ Rate \times 2^{CD} \times 16 \times DL \times 2}$$

For example, generation of 19,200 baud with CD bits = 3 (Table 91 gives DL = 0x08) is

$$M + \frac{N}{2048} = \frac{41.78\text{MHz}}{19,200 \times 2^3 \times 16 \times 8 \times 2}$$

$$M + \frac{N}{2048} = 1.06$$

where:

$$M = 1.$$

$$N = 0.06 \times 2048 = 128.$$

$$Baud\ Rate = \frac{41.78\text{MHz}}{2^3 \times 16 \times 8 \times 2 \times \left( \frac{128}{2048} \right)}$$

where:

$$Baud\ Rate = 19,200\text{ bps.}$$

Error is 0%, compared to 6.25% with the normal baud rate generator.

**UART Register Definitions**

**COM0TX Register**

Name: COM0TX  
 Address: 0xFFFF0700  
 Default Value: 0x00  
 Access: Read/write

COM0TX is an 8-bit transmit register for UART0.

**COM1TX Register**

Name: COM1TX  
 Address: 0xFFFF0740  
 Default Value: 0x00  
 Access: Read/write

COM1TX is an 8-bit transmit register for UART1.

**COM0RX Register**

Name: COM0RX  
 Address: 0xFFFF0700  
 Default Value: 0x00  
 Access: Read only

COM0RX is an 8-bit receive register for UART0.

**COM1RX Register**

Name: COM1RX  
 Address: 0xFFFF0740  
 Default Value: 0x00  
 Access: Read only

COM1RX is an 8-bit receive register for UART1.

**COM0DIV0 Register**

Name: COM0DIV0  
 Address: 0xFFFF0700  
 Default Value: 0x00  
 Access: Read/write

COM0DIV0 is a low byte divisor latch for UART0. COM0TX, COM0RX, and COM0DIV0 share the same address location. COM0TX and COM0RX can be accessed when Bit 7 in the COM0CON0 register is cleared. COM0DIV0 can be accessed when Bit 7 of COM0CON0 is set.

**COM1DIV0 Register**

Name: COM1DIV0  
 Address: 0xFFFF0740  
 Default Value: 0x00  
 Access: Read/write

COM1DIV0 is a low byte divisor latch for UART1. COM1TX, COM1RX, and COM1DIV0 share the same address location. COM1TX and COM1RX can be accessed when Bit 7 in COM1CON0 register is cleared. COM1DIV0 can be accessed when Bit 7 of COM1CON0 is set.

**COM0IEN0 Register**

Name: COM0IEN0  
 Address: 0xFFFF0704  
 Default Value: 0x00  
 Access: Read/write

COM0IEN0 is the interrupt enable register for UART0.

**COM1IEN0 Register**

Name: COM1IEN0  
 Address: 0xFFFF0744  
 Default Value: 0x00  
 Access: Read/write

COM1IEN0 is the interrupt enable register for UART1.

**Table 92. COMxIEN0 MMR Bit Descriptions**

Bit	Name	Description
[7:4]		Reserved.
3	EDSSI	Modem status interrupt enable bit. Set by the user to enable generation of an interrupt if any of COMXSTA1[3:1] are set. Cleared by the user.
2	ELSI	Rx status interrupt enable bit. Set by the user to enable generation of an interrupt if any of COMxSTA0[3:0] are set. Cleared by the user.
1	ETBEI	Enable transmit buffer empty interrupt. Set by the user to enable interrupt when the buffer is empty during a transmission. Cleared by the user.
0	ERBFI	Enable receive buffer full interrupt. In non-FIFO mode, set by the user to enable an interrupt when buffer is full during a reception. Cleared by the user. In FIFO mode, set by the user to enable an interrupt when trigger level is reached. It also controls the character receive timeout interrupt. Cleared by the user.

**COM0DIV1 Register**

Name: COM0DIV1  
 Address: 0xFFFF0704  
 Default Value: 0x00  
 Access: Read/write

COM0DIV1 is a divisor latch (high byte) register for UART0.

**COM1DIV1 Register**

Name: COM1DIV1  
 Address: 0xFFFF0744  
 Default Value: 0x00  
 Access: Read/write

COM1DIV1 is a divisor latch (high byte) register for UART1.

**COM0IID0 Register**

Name: COM0IID0  
 Address: 0xFFFF0708  
 Default Value: 0x01  
 Access: Read only

COM0IID0 is the interrupt identification register for UART0. It also indicates if the UART is in FIFO mode.

**COM1IID0 Register**

Name: COM1IID0  
 Address: 0xFFFF0748  
 Default Value: 0x01  
 Access: Read only

COM1IID0 is the interrupt identification register for UART1. It also indicates if the UART is in FIFO mode.

Table 93. COMxIID0 MMR Bit Descriptions

Bit	Name	Description
[7:6]	FIFOMODE	FIFO mode flag. 0x0: non-FIFO mode. 0x1: reserved. 0x2: reserved. 0x3: FIFO mode. Set automatically if FIFOEN is set.
[5:4]	Reserved	
[3:1]	STATUS[2:0]	Interrupt status bits that work only when NINT is set. [000]: modem status interrupt. Cleared by reading COMxSTA1. Priority 4. [001]: for non-FIFO mode, transmit buffer empty interrupt. For FIFO mode, Tx FIFO is empty. Cleared by writing COMxTX or reading COMxIID0. Priority 3. [010]: non-FIFO mode. Receive buffer data ready interrupt. Cleared automatically by reading COMxRX. For FIFO mode, set trigger level reached. Cleared automatically when FIFO drops below the trigger level. Priority 2. [011]: receive line status error interrupt. Cleared by reading COMxSTA0. Priority 1. [110]: Rx FIFO timeout interrupt (FIFO mode only). Set automatically if there is at least one byte in the Rx FIFO, and there is no access to the Rx FIFO in the next four-frames accessing cycle. Cleared by reading COMxRX, setting RXRST, or when a new byte arrives in the Rx FIFO <sup>1</sup> . Priority 2. [Other state]: reserved.
0	NINT	Set to disable interrupt flags by STATUS[2:0]. Clear to enable interrupt.

<sup>1</sup> A frame time is the time allotted for one start bit, n data bits, one parity bit, and one stop bit. Here, n is the word length selected with the WLS bits in COMxCON0.

WLS[1:0] = 00: timeout threshold = time for 32 bits = (1 + 5 + 1 + 1) × 4.

WLS[1:0] = 01: timeout threshold = time for 36 bits = (1 + 6 + 1 + 1) × 4.

WLS[1:0] = 10: timeout threshold = time for 40 bits = (1 + 7 + 1 + 1) × 4.

WLS[1:0] = 11: timeout threshold = time for 44 bits = (1 + 8 + 1 + 1) × 4.

### COM0FCR Register

Name: COM0FCR  
Address: 0xFFFF0708  
Default Value: 0x00  
Access: Read/write

The FIFO control register (FCR) is a write-only register at the same address as the interrupt identification register (IIR), which is a read-only register.

### COM1FCR Register

Name: COM1FCR  
Address: 0xFFFF0748  
Default Value: 0x00  
Access: Read/write

The FIFO control register (FCR) is a write-only register at the same address as the interrupt identification register (IIR), which is a read-only register.

Table 94. COMxFCR MMR Bit Descriptions

Bit	Name	Description
[7:5]	RXFIFOTL	Receiver FIFO trigger level. RXFIFOTL sets the trigger level for the receiver FIFO. When the trigger level is reached, a receiver data-ready interrupt is generated (if the interrupt request is enabled). When the FIFO drops below the trigger level, the interrupt is cleared. 0x0: one byte. 0x1: two bytes. 0x2: four bytes. 0x3: six bytes. 0x4: eight bytes. 0x5: 10 bytes. 0x6: 12 bytes. 0x7: 14 bytes.
[4:3]	Reserved	
2	TXRST	Tx FIFO reset. Writing a 1 flushes the Tx FIFO. Does not affect shift register. Note that TXRST should be cleared manually to make Tx FIFO work after flushing.
1	RXRST	Rx FIFO reset. Writing a 1 flushes the Rx FIFO. Does not affect shift register. Note that RXRST should be cleared manually to make the Rx FIFO work after flushing.
0	FIFOEN	Transmitter and receiver FIFOs mode enable. FIFOEN must be set before other FCR bits are written to. Set for FIFO mode. The transmitter and receiver FIFOs are enabled. Cleared for non-FIFO mode; the transmitter and receiver FIFOs are disabled, and the FIFO pointers are cleared.

### COM0CON0 Register

Name: COM0CON0  
Address: 0xFFFF070C  
Default Value: 0x00  
Access: Read/write

COM0CON0 is the line control register for UART0.

## COM1CON0 Register

Name: COM1CON0  
 Address: 0xFFFF074C  
 Default Value: 0x00  
 Access: Read/write

COM1CON0 is the line control register for UART1.

**Table 95. COMxCON0 MMR Bit Descriptions**

Bit	Name	Description
7	DLAB	Divisor latch access. Set by the user to enable access to the COMxDIV0 and COMxDIV1 registers. Cleared by the user to disable access to COMxDIV0 and COMxDIV1 and enable access to COMxRX and COMxTX.
6	BRK	Set break. Set by the user to force SOUTx to 0. Cleared to operate in normal mode.
5	SP	Stick parity. Set by the user to force parity to defined values: 1 if EPS = 1 and PEN = 1, 0 if EPS = 0 and PEN = 1.
4	EPS	Even parity select bit. Set for even parity. Cleared for odd parity.
3	PEN	Parity enable bit. Set by the user to transmit and check the parity bit. Cleared by the user for no parity transmission or checking.
2	Stop	Stop bit. Set by the user to transmit 1½ stop bits if the word length is five bits or two stop bits if the word length is six bits, seven bits, or eight bits. The receiver checks the first stop bit only, regardless of the number of stop bits selected. Cleared by the user to generate one stop bit in the transmitted data.
[1:0]	WLS	Word length select: 00 = five bits, 01 = six bits, 10 = seven bits, 11 = eight bits.

## COM0CON1 Register

Name: COM0CON1  
 Address: 0xFFFF0710  
 Default Value: 0x00  
 Access: Read/write

COM0CON1 is the modem control register for UART0.

## COM1CON1 Register

Name: COM1CON1  
 Address: 0xFFFF0750  
 Default Value: 0x00  
 Access: Read/write

COM1CON1 is the modem control register for UART1.

**Table 96. COMxCON1 MMR Bit Descriptions**

Bit	Name	Description
[7:5]		Reserved.
4	LOOPBACK	Loop back. Set by the user to enable loopback mode. In loopback mode, SOUTx is forced high. The modem signals are also directly connected to the status inputs (RTS to CTS and DTR to DSR). Cleared by the user to be in normal mode.
3	PEN	Parity enable bit. Set by the user to transmit and check the parity bit. Cleared by the user for no parity transmission or checking.
2	Stop	Stop bit. Set by the user to transmit 1½ stop bits if the word length is five bits or two stop bits if the word length is six bits, seven bits, or eight bits. The receiver checks the first stop bit only, regardless of the number of stop bits selected. Cleared by the user to generate one stop bit in the transmitted data.
1	RTS	Request to send. Set by the user to force the RTS output to 0. Cleared by the user to force the RTS output to 1.
0	DTR	Data terminal ready. Set by the user to force the DTR output to 0. Cleared by the user to force the DTR output to 1.

## COM0STA0 Register

Name: COM0STA0  
 Address: 0xFFFF0714  
 Default Value: 0xE0  
 Access: Read only

COM0STA0 is the line status register for UART0.

**COM1STA0 Register**

Name: COM1STA0

Address: 0xFFFF0754

Default Value: 0xE0

Access: Read only

COM1STA0 is the line status register for UART1.

**Table 97. COMxSTA0 MMR Bit Descriptions**

Bit	Name	Description
11	RX_error	Set automatically if PE, FE, or BI is set. Cleared automatically when PE, FE, and BI are cleared.
10	RX_timeout	Only for FIFO mode. Set automatically if there is at least one byte in the Rx FIFO and there is no access to the Rx FIFO in the next 4-byte accessing cycle.
9	RX_triggered	Only for FIFO mode. Set automatically if the Rx FIFO number exceeds the trigger level, which is configured by the FIFO control register COMxFCR[7:5]. Cleared automatically when the Rx FIFO number is equal to or less than the trigger level.
8	TX_full	Only for FIFO mode. Set automatically if Tx FIFO is full. Cleared automatically when Tx FIFO is not full.
7	TX_half_empty	Only for FIFO mode. Set automatically if the Tx FIFO is half empty (number of bytes in Tx FIFO $\leq$ 8). Cleared automatically when the Tx FIFO received bytes is more than eight bytes.
6	TEMT	COMxTX empty status bit. For non-FIFO mode, both THR and TSR are empty. For FIFO mode, both Tx FIFO and TSR are empty.
5	THRE	COMxTX and transmitter shift register empty. For non-FIFO mode, transmitter hold register (THR) empty or the content of THR has been transferred to the transmitter shift register (TSR). For FIFO mode, Tx FIFO is empty, or the last character in the FIFO has been transferred to the transmitter shift register (TSR).
4	BI	Break error. Set when SINx is held low for more than the maximum word length. Cleared automatically.
3	FE	Framing error. Set when an invalid stop bit occurs. Cleared automatically.
2	PE	Parity error. Set when a parity error occurs. Cleared automatically.

Bit	Name	Description
1	OE	Overrun error. For non-FIFO mode, set automatically if data is overwritten before being read. Cleared automatically. For FIFO mode, set automatically if an overrun error has been detected. An overrun error occurs only after the FIFO is full and the next character has been completely received in the shift register. The new character overwrites the character in the shift register, but it is not transferred to the FIFO.
0	DR	Data ready. For non-FIFO mode, set automatically when COMxRX is full. Cleared by reading COMxRX. For FIFO mode, set automatically when there is at least one unread byte in the COMxRX.

**COM0STA1 Register**

Name: COM0STA1

Address: 0xFFFF0718

Default Value: 0x00

Access: Read only

COM0STA1 is a modem status register.

**COM1STA1 Register**

Name: COM1STA1

Address: 0xFFFF0758

Default Value: 0x00

Access: Read only

COM1STA1 is a modem status register.

**Table 98. COMxSTA1 MMR Bit Descriptions**

Bit	Name	Description
7	DCD	Data carrier detect.
6	RI	Ring indicator.
5	DSR	Data set ready.
4	CTS	Clear to send.
3	DDCD	Delta DCD. Set automatically if DCD changed state since last COMxSTA1 read. Cleared automatically by reading COMxSTA1.
2	TERI	Trailing edge RI. Set if RI changed from 0 to 1 since COMxSTA1 last read. Cleared automatically by reading COMxSTA1.
1	DDSR	Delta DSR. Set automatically if DSR changed state since COMxSTA1 last read. Cleared automatically by reading COMxSTA1.
0	DCTS	Delta CTS. Set automatically if CTS changed state since COMxSTA1 last read. Cleared automatically by reading COMxSTA1.

**COM0DIV2 Register**

Name:	COM0DIV2
Address:	0xFFFF072C
Default Value:	0x0000
Access:	Read/write

COM0DIV2 is a 16-bit fractional baud divide register for UART0.

**COM1DIV2 Register**

Name:	COM1DIV2
Address:	0xFFFF076C
Default Value:	0x0000
Access:	Read/write

COM1DIV2 is a 16-bit fractional baud divide register for UART1.

**Table 99. COMxDIV2 MMR Bit Descriptions**

Bit	Name	Description
15	FBEN	Fractional baud rate generator enable bit. Set by the user to enable the fractional baud rate generator. Cleared by the user to generate the baud rate using the standard 450 UART baud rate generator.
[14:13]		Reserved.
[12:11]	FBM[1:0]	M if FBM = 0, M = 4 (see The Fractional Divider section).
[10:0]	FBN[10:0]	N (see The Fractional Divider section).

**SERIAL PERIPHERAL INTERFACE**

The ADuC7124/ADuC7126 integrate a complete hardware serial peripheral interface (SPI) on chip. SPI is an industry standard, synchronous serial interface that allows eight bits of data to be synchronously transmitted and simultaneously received, that is, full duplex up to a maximum bit rate of 20 Mbps.

The SPI port can be configured for master or slave operation and typically consists of four pins: MISO, MOSI, SCLK, and  $\overline{CS}$ .

**MISO (Master In, Slave Out) Pin**

The MISO pin is configured as an input line in master mode and an output line in slave mode. The MISO line on the master (data in) should be connected to the MISO line in the slave device (data out). The data is transferred as byte wide (8-bit) serial data, MSB first.

**MOSI (Master Out, Slave In) Pin**

The MOSI pin is configured as an output line in master mode and an input line in slave mode. The MOSI line on the master

(data out) should be connected to the MOSI line in the slave device (data in). The data is transferred as byte wide (8-bit) serial data, MSB first.

**SCLK (Serial Clock I/O) Pin**

The master serial clock (SCLK) synchronizes the data being transmitted and received through the MOSI SCLK period. Therefore, a byte is transmitted/received after eight SCLK periods. The SCLK pin is configured as an output in master mode and as an input in slave mode.

In master mode, polarity and phase of the clock are controlled by the SPICON register, and the bit rate is defined in the SPIDIV register as follows:

$$f_{SERIAL\ CLOCK} = \frac{f_{UCLK}}{2 \times (1 + SPIDIV)}$$

The maximum speed of the SPI clock is independent of the clock divider bits.

In slave mode, the SPICON register must be configured with the phase and polarity of the expected input clock. The slave accepts data from an external master up to 10 Mbps.

In both master and slave modes, data is transmitted on one edge of the SCLK signal and sampled on the other. Therefore, it is important that the polarity and phase be configured the same for the master and slave devices.

 **$\overline{CS}$  (SPI Chip Select Input) Pin**

In SPI slave mode, a transfer is initiated by the assertion of  $\overline{CS}$ , which is an active low input signal. The SPI port then transmits and receives 8-bit data until the transfer is concluded by deassertion of  $\overline{CS}$ . In slave mode,  $\overline{CS}$  is always an input.

In SPI master mode, the  $\overline{CS}$  is an active low output signal. It asserts itself automatically at the beginning of a transfer and deasserts itself upon completion.

**Configuring External Pins for SPI functionality**

The SPI pins of the ADuC7124/ADuC7126 device are P1.4 to P1.7.

P1.7 is the slave chip select pin. In slave mode, this pin is an input and must be driven low by the master. In master mode, this pin is an output and goes low at the beginning of a transfer and high at the end of a transfer.

P1.4 is the SCLK pin.

P1.5 is the master in, slave out (MISO) pin.

P1.6 is the master out, slave in (MOSI) pin.

To configure P1.4 to P1.7 for SPI mode, see the General-Purpose Input/Output section.

**SPI Registers**

The following MMR registers control the SPI interface: SPISTA, SPIRX, SPITX, SPIDIV, and SPICON.

**SPI Status Register**

Name: SPISTA

Address: 0xFFFF0A00

Default Value: 0x0000

Access: Read only

Function: This 32-bit MMR contains the status of the SPI interface in both master and slave modes.

**Table 100. SPISTA MMR Bit Descriptions**

Bit	Name	Description
[15:12]		Reserved.
11	SPIREX	SPI Rx FIFO excess bytes present. This bit is set when there are more bytes in the Rx FIFO than indicated in the SPIMDE bits in SPICON This bit is cleared when the number of bytes in the FIFO is equal to or less than the number in SPIMDE.
[10:8]	SPIRXFSTA[2:0]	SPI Rx FIFO status bits. [000] = Rx FIFO is empty. [001] = one valid byte in the FIFO. [010] = two valid bytes in the FIFO. [011] = three valid bytes in the FIFO. [100] = four valid bytes in the FIFO.
7	SPIFOF	SPI Rx FIFO overflow status bit. Set when the Rx FIFO was already full when new data was loaded to the FIFO. This bit generates an interrupt except when SPIRFLH is set in SPICON. Cleared when the SPISTA register is read.
6	SPIRXIRQ	SPI Rx IRQ status bit. Set when a receive interrupt occurs. This bit is set when SPITMDE in SPICON is cleared and the required number of bytes has been received. Cleared when the SPISTA register is read.
5	SPITXIRQ	SPI Tx IRQ status bit. Set when a transmit interrupt occurs. This bit is set when SPITMDE in SPICON is set and the required number of bytes has been transmitted. Cleared when the SPISTA register is read.
4	SPITXUF	SPI Tx FIFO underflow. This bit is set when a transmit is initiated without any valid data in the Tx FIFO. This bit generates an interrupt except when SPITFLH is set in SPICON. Cleared when the SPISTA register is read.
[3:1]	SPITXFSTA[2:0]	SPI Tx FIFO status bits. [000] = Tx FIFO is empty. [001] = one valid byte in the FIFO. [010] = two valid bytes in the FIFO. [011] = three valid bytes in the FIFO. [100] = four valid bytes in the FIFO.
0	SPISTA	SPI interrupt status bit. Set to 1 when an SPI-based interrupt occurs. Cleared after reading SPISTA.

**SPIRX Register**

Name: SPIRX  
 Address: 0xFFFF0A04  
 Default Value: 0x00  
 Access: Read only  
 Function: This 8-bit MMR is the SPI receive register.

**SPITX Register**

Name: SPITX  
 Address: 0xFFFF0A08  
 Default Value: 0x00  
 Access: Write only  
 Function: This 8-bit MMR is the SPI transmit register.

**SPIDIV Register**

Name: SPIDIV  
 Address: 0xFFFF0A0C  
 Default Value: 0x00  
 Access: Read/write  
 Function: This 8-bit MMR is the SPI baud rate selection register.

**SPICON Register**

Name: SPICON  
 Address: 0xFFFF0A10  
 Default Value: 0x0000  
 Access: Read/write  
 Function: This 16-bit MMR configures the SPI peripheral in both master and slave modes.

**Table 101. SPICON MMR Bit Descriptions**

Bit	Name	Description
[15:14]	SPIMDE	SPI IRQ mode bits. These bits configure when the Tx/Rx interrupts occur in a transfer. [00] = Tx interrupt occurs when one byte has been transferred. Rx interrupt occurs when one or more bytes have been received into the FIFO. [01] = Tx interrupt occurs when two bytes have been transferred. Rx interrupt occurs when two or more bytes have been received into the FIFO. [10] = Tx interrupt occurs when three bytes have been transferred. Rx interrupt occurs when three or more bytes have been received into the FIFO. [11] = Tx interrupt occurs when four bytes have been transferred. Rx interrupt occurs when the Rx FIFO is full or four bytes are present.
13	SPITFLH	SPI Tx FIFO flush enable bit. Set this bit to flush the Tx FIFO. This bit does not clear itself and should be toggled if a single flush is required. If this bit is left high, then either the last transmitted value or 0x00 is transmitted, depending on the SPIZEN bit. Any writes to the Tx FIFO are ignored while this bit is set. Clear this bit to disable Tx FIFO flushing.
12	SPIRFLH	SPI Rx FIFO flush enable bit. Set this bit to flush the Rx FIFO. This bit does not clear itself and should be toggled if a single flush is required. If this bit is set incoming, data is ignored and no interrupts are generated. If set and SPITMDE = 0, a read of the Rx FIFO initiates a transfer. Clear this bit to disable Rx FIFO flushing.
11	SPICONT	Continuous transfer enable. Set by the user to enable continuous transfer. In master mode, the transfer continues until no valid data is available in the SPITX register. $\overline{CS}$ is asserted and remains asserted for the duration of each 8-bit serial transfer until SPITX is empty. Cleared by the user to disable continuous transfer. Each transfer consists of a single 8-bit serial transfer. If valid data exists in the SPITX register, then a new transfer is initiated after a stall period of one serial clock cycle.
10	SPILP	Loopback enable bit. Set by the user to connect MISO to MOSI and test software. Cleared by the user to be in normal mode.

Bit	Name	Description
9	SPIOEN	Slave MISO output enable bit. Set this bit for MISO to operate as normal. Clear this bit to disable the output driver on the MISO pin. The MISO pin is open-drain when this bit is cleared.
8	SPIROW	SPIRX overflow overwrite enable. Set by the user, the valid data in the SPIRX register is overwritten by the new serial byte received. Cleared by the user, the new serial byte received is discarded.
7	SPIZEN	SPI transmits zeros when Tx FIFO is empty. Set this bit to transmit 0x00 when there is no valid data in the Tx FIFO. Clear this bit to transmit the last transmitted value when there is no valid data in the Tx FIFO.
6	SPITMDE	SPI transfer and interrupt mode. Set by the user to initiate transfer with a write to the SPITX register. Interrupt occurs only when SPITX is empty. Cleared by the user to initiate transfer with a read of the SPIRX register. Interrupt occurs only when SPIRX is full.
5	SPIILF	LSB first transfer enable bit. Set by the user, the LSB is transmitted first. Cleared by the user, the MSB is transmitted first.
4	SPIWOM	SPI wire-OR'ed mode enable bit. Set to 1 enable open-drain data output. External pull-ups required on data output pins. Cleared for normal output levels.
3	SPICPO	Serial clock polarity mode bit. Set by the user, the serial clock idles high. Cleared by the user, the serial clock idles low.
2	SPICPH	Serial clock phase mode bit. Set by the user, the serial clock pulses at the beginning of each serial bit transfer. Cleared by the user, the serial clock pulses at the end of each serial bit transfer.
1	SPIMEN	Master mode enable bit. Set by the user to enable master mode. Cleared by the user to enable slave mode.
0	SPIEN	SPI enable bit. Set by the user to enable the SPI. Cleared by the user to disable the SPI.

## I<sup>2</sup>C

The ADuC7124/ADuC7126 incorporate two I<sup>2</sup>C peripherals that can be configured as a fully I<sup>2</sup>C-compatible I<sup>2</sup>C bus master device or as a fully I<sup>2</sup>C bus compatible slave device. Both I<sup>2</sup>C channels are identical. Therefore, the following descriptions apply to both channels.

The two pins used for data transfer, SDA and SCL, are configured in a wire-ANDed format that allows arbitration in a multimaster system. These pins require external pull-up resistors. Typical pull-up values are between 4.7 kΩ and 10 kΩ.

The I<sup>2</sup>C bus peripheral address in the I<sup>2</sup>C bus system is programmed by the user. This ID can be modified any time a transfer is not in progress. The user can configure the interface to respond to four slave addresses.

The transfer sequence of an I<sup>2</sup>C system consists of a master device initiating a transfer by generating a start condition while the bus is idle. The master transmits the slave device address and the direction of the data transfer (read or/write) during the initial address transfer. If the master does not lose arbitration and the slave acknowledges, the data transfer is initiated. This continues until the master issues a stop condition and the bus becomes idle.

The I<sup>2</sup>C peripheral can only be configured as a master or slave at any given time. The same I<sup>2</sup>C channel cannot simultaneously support master and slave modes.

The I<sup>2</sup>C interface on the ADuC7124/ADuC7126 includes the following features:

- Support for repeated start conditions. In master mode, the ADuC7124/ADuC7126 can be programmed to generate a repeated start. In slave mode, the ADuC7124/ADuC7126 recognizes repeated start conditions.
- In master and slave mode, the part recognizes both 7-bit and 10-bit bus addresses.
- In I<sup>2</sup>C master mode, the ADuC7124/ADuC7126 supports continuous reads from a single slave up to 512 bytes in a single transfer sequence.
- Clock stretching can be enabled by other devices on the bus without causing any issues with the ADuC7124/ADuC7126. However, the ADuC7124/ADuC7126 cannot enable clock stretching.
- In slave mode, the ADuC7124/ADuC7126 can be programmed to return a NACK. This allows the validation of checksum bytes at the end of I<sup>2</sup>C transfers.
- Bus arbitration in master mode is supported.
- Internal and external loopback modes are supported for I<sup>2</sup>C hardware testing in loopback mode.
- The transmit and receive circuits in both master and slave mode contain 2-byte FIFOs. Status bits are available to the user to control these FIFOs.

## Configuring External Pins for I<sup>2</sup>C Functionality

The I<sup>2</sup>C pins of the ADuC7124/ADuC7126 device are P1.0 and P1.1 for I2C0 and P1.2 and P1.3 for I2C1.

P1.0 and P1.2 are the I<sup>2</sup>C clock signals, and P1.1 and P1.3 are the I<sup>2</sup>C data signals. For instance, to configure I2C0 pins (SCL0, SDA0), Bit 0 and Bit 4 of the GP1CON register must be set to 1 to enable I<sup>2</sup>C mode. On the other hand, to configure I2C1 pins (SCL1, SDA1), Bit 8 and Bit 12 of the GP1CON register must be set to 1 to enable I<sup>2</sup>C mode, as shown in the General-Purpose Input/Output section.

## Serial Clock Generation

The I<sup>2</sup>C master in the system generates the serial clock for a transfer. The master channel can be configured to operate in fast mode (400 kHz) or standard mode (100 kHz).

The bit rate is defined in the I2CxDIV MMR as follows:

$$f_{\text{SERIAL CLOCK}} = \frac{f_{\text{UCLK}}}{(2 + \text{DIVH}) + (2 + \text{DIVL})}$$

where:

$f_{\text{UCLK}}$  is the clock before the clock divider.

$\text{DIVH}$  is the high period of the clock.

$\text{DIVL}$  is the low period of the clock.

Therefore, for 100 kHz operation,

$$\text{DIVH} = \text{DIVL} = 0\text{xCF}$$

and for 400 kHz

$$\text{DIVH} = 0\text{x28}, \text{DIVL} = 0\text{x3C}$$

The I2CxDIV register corresponds to DIVH:DIVL.

## I<sup>2</sup>C Bus Addresses

### Slave Mode

In slave mode, the I2CxID0, I2CxID1, I2CxID2, and I2CxID3 registers contain the device IDs. The device compares the four I2CxIDx registers to the address byte received from the bus master. To be correctly addressed, the seven MSBs of either ID register must be identical to the seven MSBs of the first received address byte. The LSB of the ID registers (the transfer direction bit) is ignored in the process of address recognition.

The ADuC7124/ADuC7126 also support 10-bit addressing mode. When Bit 1 of I2CxSCON (ADR10EN bit) is set to 1, one 10-bit address is supported in slave mode and is stored in the I2CxID0 and I2CxID1 registers. The 10-bit address is derived as follows:

I2CxID0[0] is the read/write bit and is not part of the I<sup>2</sup>C address.

$$\text{I2CxID0}[7:1] = \text{Address Bits}[6:0].$$

$$\text{I2CxID1}[2:0] = \text{Address Bits}[9:7].$$

I2CxID1[7:3] must be set to 11110b.

**Master Mode**

In master mode, the I2CxADR0 register is programmed with the I<sup>2</sup>C address of the device.

In 7-bit address mode, I2CxADR0[7:1] are set to the device address. I2CxADR0[0] is the read/write bit.

In 10-bit address mode, the 10-bit address is created as follows:

I2CxADR0[7:3] must be set to 11110b.

I2CxADR0[2:1] = Address Bits[9:8].

I2CxADR1[7:0] = Address Bits[7:0].

I2CxADR0[0] is the read/write bit.

**I<sup>2</sup>C Registers**

The I<sup>2</sup>C peripheral interfaces consists of a number of MMRs. These are described in the I2C Master Registers section.

**I<sup>2</sup>C Master Registers****I<sup>2</sup>C Master Control Register**

Name: I2C0MCON, I2C1MCON

Address: 0xFFFF0800, 0xFFFF0900

Default Value: 0x0000, 0x0000

Value:

Access: Read/write

Function: This 16-bit MMR configures the I<sup>2</sup>C peripheral in master mode.

**Table 102. I2CxMCON MMR Bit Descriptions**

Bit	Name	Description
[15:9]		Reserved. These bits are reserved and should not be written to.
8	I2CMCENI	I <sup>2</sup> C transmission complete interrupt enable bit. Set this bit to enable an interrupt on detecting a stop condition on the I <sup>2</sup> C bus. Clear this bit to clear the interrupt source.
7	I2CNACKENI	I <sup>2</sup> C no acknowledge (NACK) received interrupt enable bit. Set this bit to enable interrupts when the I <sup>2</sup> C master receives a NACK. Clear this bit to clear the interrupt source.
6	I2CALENI	I <sup>2</sup> C arbitration lost interrupt enable bit. Set this bit to enable interrupts when the I <sup>2</sup> C master is unable to gain control of the I <sup>2</sup> C bus. Clear this bit to clear the interrupt source.
5	I2CMTENI	I <sup>2</sup> C transmit interrupt enable bit. Set this bit to enable interrupts when the I <sup>2</sup> C master has transmitted a byte. Clear this bit to clear the interrupt source.
4	I2CMRENI	I <sup>2</sup> C receive interrupt enable bit. Set this bit to enable interrupts when the I <sup>2</sup> C master receives data. Cleared by user to disable interrupts when the I <sup>2</sup> C master is receiving data.
3	RESERVED	Reserved. A value of 0 should be written to this bit.
2	I2CILEN	I <sup>2</sup> C internal loopback enable. Set this bit to enable loopback test mode. In this mode, the SCL and SDA signals are connected internally to their respective input signals. Cleared by the user to disable loopback mode.
1	I2CBD	I <sup>2</sup> C master backoff disable bit. Set this bit to allow the device to compete for control of the bus even if another device is currently driving a start condition. Clear this bit to wait until the I <sup>2</sup> C bus becomes free.
0	I2CMEN	I <sup>2</sup> C master enable bit. Set by the user to enable I <sup>2</sup> C master mode. Clear this bit to disable I <sup>2</sup> C master mode.

**I<sup>2</sup>C Master Status Register**

Name: I2C0MSTA, I2C1MSTA

Address: 0xFFFF0804, 0xFFFF0904

Default Value: 0x0000, 0x0000

Access: Read only

Function: This 16-bit MMR is the I<sup>2</sup>C status register in master mode.**Table 103. I2CxMSTA MMR Bit Descriptions**

Bit	Name	Description
[15:11]		Reserved.
10	I2CBBUSY	I <sup>2</sup> C bus busy status bit. This bit is set to 1 when a start condition is detected on the I <sup>2</sup> C bus. This bit is cleared when a stop condition is detected on the bus.
9	I2CMRxFO	Master Rx FIFO overflow. This bit is set to 1 when a byte is written to the Rx FIFO when it is already full. This bit is cleared in all other conditions.
8	I2CMTC	I <sup>2</sup> C transmission complete status bit. This bit is set to 1 when a transmission is complete between the master and the slave it was communicating with. If the I2CMCENI bit in I2CxMCON is set, an interrupt is generated when this bit is set. Clear this bit to clear the interrupt source.
7	I2CMNA	I <sup>2</sup> C master NACK data bit. This bit is set to 1 when a NACK condition is received by the master in response to a data write transfer. If the I2CNACKENI bit in I2CxMCON is set, an interrupt is generated when this bit is set. This bit is cleared in all other conditions.
6	I2CMBUSY	I <sup>2</sup> C master busy status bit. Set to 1 when the master is busy processing a transaction. Cleared if the master is ready or if another master device has control of the bus.
5	I2CAL	I <sup>2</sup> C arbitration lost status bit. This bit is set to 1 when the I <sup>2</sup> C master is unable to gain control of the I <sup>2</sup> C bus. If the I2CALENI bit in I2CxMCON is set, an interrupt is generated when this bit is set. This bit is cleared in all other conditions.
4	I2CMNA	I <sup>2</sup> C master NACK address bit. This bit is set to 1 when a NACK condition is received by the master in response to an address. If the I2CNACKENI bit in I2CxMCON is set, an interrupt is generated when this bit is set. This bit is cleared in all other conditions.
3	I2CMRXQ	I <sup>2</sup> C master receive request bit. This bit is set to 1 when data enters the Rx FIFO. If the I2CMRENI in I2CxMCON is set, an interrupt is generated. This bit is cleared in all other conditions.
2	I2CMTXQ	I <sup>2</sup> C master transmit request bit. This bit goes high if the Tx FIFO is empty or contains only one byte and the master has transmitted an address + write. If the I2CMTENI bit in I2CxMCON is set, an interrupt is generated when this bit is set. This bit is cleared in all other conditions.
[1:0]	I2CMTFSTA	I <sup>2</sup> C master Tx FIFO status bits. 00 = I <sup>2</sup> C master Tx FIFO empty. 01 = one byte in master Tx FIFO. 10 = one byte in master Tx FIFO. 11 = I <sup>2</sup> C master Tx FIFO full.

**I<sup>2</sup>C Master Receive Register**

Name: I2C0MRX, I2C1MRX  
 Address: 0xFFFF0808, 0xFFFF0908  
 Default Value: 0x00  
 Access: Read only  
 Function: This 8-bit MMR is the I<sup>2</sup>C master receive register.

**I<sup>2</sup>C Master Transmit Register**

Name: I2C0MTX, I2C1MTX  
 Address: 0xFFFF080C, 0xFFFF090C  
 Default Value: 0x00, 0x00  
 Access: Read/write  
 Function: This 8-bit MMR is the I<sup>2</sup>C master transmit register.

**I<sup>2</sup>C Master Read Count Register**

Name: I2C0MCNT0, I2C1MCNT0  
 Address: 0xFFFF0810, 0xFFFF0910  
 Default Value: 0x0000, 0x0000  
 Access: Read/write  
 Function: This 16-bit MMR holds the required number of bytes when the master begins a read sequence from a slave device.

**Table 104. I2CxMCNT0 MMR Bit Descriptions**

Bit	Name	Description
[15:9]		Reserved.
8	I2CRECNT	Set this bit if more than 256 bytes are required from the slave. Clear this bit when reading 256 bytes or less.
[7:0]	I2CRCNT	These eight bits hold the number of bytes required during a slave read sequence, minus 1. If only a single byte is required, these bits should be set to 0.

**I<sup>2</sup>C Master Current Read Count Register**

Name: I2C0MCNT1, I2C1MCNT1  
 Address: 0xFFFF0814, 0xFFFF0914  
 Default Value: 0x00, 0x00  
 Access: Read only  
 Function: This 8-bit MMR holds the number of bytes received so far during a read sequence with a slave device.

**I<sup>2</sup>C Address 0 Register**

Name: I2C0ADR0, I2C1ADR0  
 Address: 0xFFFF0818, 0xFFFF0918  
 Default Value: 0x00  
 Access: Read/write  
 Function: This 8-bit MMR holds the 7-bit slave address + the read/write bit when the master begins communicating with a slave.

**Table 105. I2CxADR0 MMR in 7-Bit Address Mode**

Bit	Name	Description
[7:1]	I2CADR	These bits contain the 7-bit address of the required slave device.
0	R/W	Bit 0 is the read/write bit. When this bit = 1, a read sequence is requested. When this bit = 0, a write sequence is requested.

**Table 106. I2CxADR0 MMR in 10-Bit Address Mode**

Bit	Name	Description
[7:3]		These bits must be set to [11110b] in 10-bit address mode.
[2:1]	I2CMADR	These bits contain ADDR[9:8] in 10-bit addressing mode.
0	R/W	Read/write bit. When this bit = 1, a read sequence is requested. When this bit = 0, a write sequence is requested.

**I<sup>2</sup>C Address 1 Register**

Name: I2C0ADR1, I2C1ADR1  
 Address: 0xFFFF081C, 0xFFFF091C  
 Default Value: 0x00  
 Access: Read/write  
 Function: This 8-bit MMR is used in 10-bit addressing mode only. This register contains the least significant byte of the address.

**Table 107. I2CxADR1 MMR in 10-Bit Address Mode**

Bit	Name	Description
[7:0]	I2CLADR	These bits contain ADDR[7:0] in 10-bit addressing mode.

**I<sup>2</sup>C Master Clock Control Register**

Name: I2C0DIV, I2C1DIV  
 Address: 0xFFFF0824, 0xFFFF0924  
 Default Value: 0x1F1F  
 Access: Read/write  
 Function: This MMR controls the frequency of the I<sup>2</sup>C clock generated by the master on to the SCL pin. For further details, see the I<sup>2</sup>C section.

**Table 108. I2CxDIV MMR**

Bit	Name	Description
[15:8]	DIVH	These bits control the duration of the high period of SCL.
[7:0]	DIVL	These bits control the duration of the low period of SCL.

**I<sup>2</sup>C Slave Registers****I<sup>2</sup>C Slave Control Register**

Name: I2C0SCON, I2C1SCON  
 Address: 0xFFFF0828, 0xFFFF0928  
 Default Value: 0x0000  
 Access: Read/write  
 Function: This 16-bit MMR configures the I<sup>2</sup>C peripheral in slave mode.

**Table 109. I2CxSCON MMR Bit Descriptions**

Bit	Name	Description
[15:11]		Reserved.
10	I2CSTXENI	Slave transmit interrupt enable bit. Set this bit to enable an interrupt after a slave transmits a byte. Clear this interrupt source.
9	I2CSRXENI	Slave receive interrupt enable bit. Set this bit to enable an interrupt after the slave receives data. Clear this interrupt source.
8	I2CSSENI	I <sup>2</sup> C stop condition detected interrupt enable bit. Set this bit to enable an interrupt on detecting a stop condition on the I <sup>2</sup> C bus. Clear this interrupt source.
7	I2CNACKEN	I <sup>2</sup> C NACK enable bit. Set this bit to NACK the next byte in the transmission sequence. Clear this bit to let the hardware control the ACK/NACK sequence.
6	RESERVED	Reserved. A value of 0 should be written to this bit.
5	I2CSETEN	I <sup>2</sup> C early transmit interrupt enable bit. Setting this bit enables a transmit request interrupt just after the positive edge of SCL during the read bit transmission. Clear this bit to enable a transmit request interrupt just after the negative edge of SCL during the read bit transmission.
4	I2CGCCLR	I <sup>2</sup> C general call status and ID clear bit. Writing a 1 to this bit clears the general call status (I2CGC) and ID (I2CGCID[1:0]) bits in the I2CxSSTA register. Clear this bit at all other times.

Bit	Name	Description
3	I2CHGCEN	<p>I<sup>2</sup>C hardware general call enable.</p> <p>When this bit and Bit 2 are set, and having received a general call (Address 0x00) and a data byte, the device checks the contents of the I2CxALT against the receive register. If the contents match, the device has received a hardware general call. This is used if a device needs urgent attention from a master device without knowing which master it needs to turn to. This is a broadcast message to all master devices on the bus. The ADuC7124/ADuC7126 watch for these addresses. The device that requires attention embeds its own address into the message. All masters listen, and the one that can handle the device contacts its slave and acts appropriately. The LSB of the I2CxALT register should always be written to 1, as per the I<sup>2</sup>C January 2000 bus specification.</p> <p>Set this bit and I2CGCEN to enable hardware general call recognition in slave mode.</p> <p>Clear this bit to disable recognition of hardware general call commands.</p>
2	I2CGCEN	<p>I<sup>2</sup>C general call enable.</p> <p>Set this bit to enable the slave device to acknowledge an I<sup>2</sup>C general call, Address 0x00 (write). The device then recognizes a data bit. If it receives a 0x06 (reset and write programmable part of the slave address by hardware) as the data byte, the I<sup>2</sup>C interface resets as per the I<sup>2</sup>C January 2000 bus specification. This command can be used to reset an entire I<sup>2</sup>C system. If it receives a 0x04 (write programmable part of the slave address by hardware) as the data byte, the general call interrupt status bit sets on any general call.</p> <p>The user must take corrective action by reprogramming the device address.</p> <p>Set this bit to allow the slave ACK I<sup>2</sup>C general call commands.</p> <p>Clear this bit to disable recognition of general call commands.</p>
1	ADR10EN	<p>I<sup>2</sup>C 10-bit address mode.</p> <p>Set to 1 to enable 10-bit address mode.</p> <p>Clear to 0 to enable normal address mode.</p>
0	I2CSEN	<p>I<sup>2</sup>C slave enable bit.</p> <p>Set by the user to enable I<sup>2</sup>C slave mode.</p> <p>Clear this bit to disable I<sup>2</sup>C slave mode.</p>

### I<sup>2</sup>C Slave Status Registers

Name: I2COSSTA, I2C1SSTA

Address: 0xFFFFF082C, 0xFFFFF092C

Default Value: 0x0000, 0x0000

Access: Read only

Function: This 16-bit MMR is the I<sup>2</sup>C status register in slave mode.

**Table 110. I2CxSSTA MMR Bit Descriptions**

Bit	Name	Description
15		Reserved.
14	I2CSTA	<p>This bit is set to 1 if a start condition followed by a matching address is detected, a start byte (0x01) is received, or general calls are enabled and a general call code of (0x00) is received.</p> <p>This bit is cleared on receiving a stop condition.</p>
13	I2CREPS	<p>This bit is set to 1 if a repeated start condition is detected.</p> <p>This bit is cleared on receiving a stop condition. A read of the I2CxSSTA register also clears this bit.</p>
[12:11]	I2CID[1:0]	<p>I<sup>2</sup>C address matching register. These bits indicate which I2CxIDx register matches the received address.</p> <p>[00] = received address matches I2CxID0.</p> <p>[01] = received address matches I2CxID1.</p> <p>[10] = received address matches I2CxID2.</p> <p>[11] = received address matches I2CxID3.</p>
10	I2CSS	<p>I<sup>2</sup>C stop condition after start detected bit.</p> <p>This bit is set to 1 when a stop condition is detected after a previous start and matching address.</p> <p>When the I2CSSENI bit in I2CxSCON is set, an interrupt is generated.</p> <p>This bit is cleared by reading this register.</p>

Bit	Name	Description
[9:8]	I2CGCID[1:0]	I <sup>2</sup> C general call ID bits. [00] = no general call received. [01] = general call reset and program address. [10] = general program address. [11] = general call matching alternative ID. Note that these bits are not cleared by a general call reset command. Clear these bits by writing a 1 to the I2CGCLR bit in I2CxSCON.
7	I2CGC	I <sup>2</sup> C general call status bit. This bit is set to 1 if the slave receives a general call command of any type. If the command received is a reset command, then all registers return to their default states. If the command received is a hardware general call, the Rx FIFO holds the second byte of the command and this can be compared with the I2CxALT register. Clear this bit by writing a 1 to the I2CGCLR bit in I2CxSCON.
6	I2CSBUSY	I <sup>2</sup> C slave busy status bit. Set to 1 when the slave receives a start condition. Cleared by hardware if the received address does not match any of the I2CxIDx registers, the slave device receives a stop condition, or a repeated start address does not match any of the I2CxIDx registers.
5	I2CSNA	I <sup>2</sup> C slave NACK data bit. This bit is set to 1 when the slave responds to a bus address with a NACK. This bit is asserted if a NACK was returned because there was no data in the Tx FIFO or the I2CNACKEN bit was set in the I2CxSCON register. This bit is cleared in all other conditions.
4	I2CSRxF0	Slave Rx FIFO overflow. This bit is set to 1 when a byte is written to the Rx FIFO when it is already full. This bit is cleared in all other conditions.
3	I2CSRXQ	I <sup>2</sup> C slave receive request bit. This bit is set to 1 when the slave Rx FIFO is not empty. This bit causes an interrupt to occur when the I2CSRXENI bit in I2CxSCON is set. The Rx FIFO must be read or flushed to clear this bit.
2	I2CSTXQ	I <sup>2</sup> C slave transmit request bit. This bit is set to 1 when the slave receives a matching address followed by a read. If the I2CSETEN bit in I2CxSCON = 0, this bit goes high just after the negative edge of SCL during the read bit transmission. If the I2CSETEN bit in I2CxSCON = 1, this bit goes high just after the positive edge of SCL during the read bit transmission. This bit causes an interrupt to occur when the I2CSTXENI bit in I2CxSCON is set. This bit is cleared in all other conditions.
1	I2CSTFE	I <sup>2</sup> C slave FIFO underflow status bit. This bit goes high if the Tx FIFO is empty when a master requests data from the slave. This bit is asserted at the rising edge of SCL during the read bit. This bit is cleared in all other conditions.
0	I2CETSTA	I <sup>2</sup> C slave early transmit FIFO status bit. If the I2CSETEN bit in I2CxSCON = 0, this bit goes high if the slave Tx FIFO is empty. If the I2CSETEN bit in I2CxSCON = 1, this bit goes high just after the positive edge of SCL during the write bit transmission. This bit asserts once only for a transfer. This bit is cleared after being read.

**I<sup>2</sup>C Slave Receive Registers**

Name: I2C0SRX, I2C1SRX  
 Address: 0xFFFF0830, 0xFFFF0930  
 Default Value: 0x00  
 Access: Read  
 Function: This 8-bit MMR is the I<sup>2</sup>C slave receive register.

**I<sup>2</sup>C Slave Transmit Registers**

Name: I2C0STX, I2C1STX  
 Address: 0xFFFF0834, 0xFFFF0934  
 Default Value: 0x00  
 Access: Write  
 Function: This 8-bit MMR is the I<sup>2</sup>C slave transmit register.

**I<sup>2</sup>C Hardware General Call Recognition Registers**

Name: I2C0ALT, I2C1ALT  
 Address: 0xFFFF0838, 0xFFFF0938  
 Default Value: 0x00  
 Access: Read/write  
 Function: This 8-bit MMR is used with hardware general calls when I2CxSCON Bit 3 is set to 1. This register is used in cases where a master is unable to generate an address for a slave, and instead, the slave must generate the address for the master.

**I<sup>2</sup>C Slave Device ID Registers**

Name: I2C0IDx, I2C1IDx  
 Addresses: 0xFFFF093C = I2C1ID0  
 0xFFFF083C = I2C0ID0  
 0xFFFF0940 = I2C1ID1  
 0xFFFF0840 = I2C0ID1  
 0xFFFF0944 = I2C1ID2  
 0xFFFF0844 = I2C0ID2  
 0xFFFF0948 = I2C1ID3  
 0xFFFF0848 = I2C0ID3  
 Default Value: 0x00  
 Access: Read/write  
 Function: These 8-bit MMRs are programmed with I<sup>2</sup>C bus IDs of the slave. See the I2C Bus Addresses section for further details.

**I<sup>2</sup>C Common Registers****I<sup>2</sup>C FIFO Status Register**

Name: I2C0FSTA, I2C1FSTA  
 Address: 0xFFFF084C, 0xFFFF094C  
 Default Value: 0x0000  
 Access: Read/write  
 Function: These 16-bit MMRs contain the status of the Rx/Tx FIFOs in both master and slave modes.

**Table 111. I2CxFSTA MMR Bit Descriptions**

Bit	Name	Description
[15:10]		Reserved.
9	I2CFMTX	Set this bit to 1 to flush the master Tx FIFO.
8	I2CFSTX	Set this bit to 1 to flush the slave Tx FIFO.
[7:6]	I2CMRXSTA	I <sup>2</sup> C master receive FIFO status bits. [00] = FIFO empty. [01] = byte written to FIFO. [10] = one byte in FIFO. [11] = FIFO full.
[5:4]	I2CMTXSTA	I <sup>2</sup> C master transmit FIFO status bits. [00] = FIFO empty. [01] = byte written to FIFO. [10] = one byte in FIFO. [11] = FIFO full.
[3:2]	I2CSRXSTA	I <sup>2</sup> C slave receive FIFO status bits. [00] = FIFO empty. [01] = byte written to FIFO. [10] = one byte in FIFO. [11] = FIFO full.
[1:0]	I2CSTXSTA	I <sup>2</sup> C slave transmit FIFO status bits. [00] = FIFO empty. [01] = byte written to FIFO. [10] = one byte in FIFO. [11] = FIFO full.

**PWM GENERAL OVERVIEW**

The ADuC7124/ADuC7126 integrate a 6-channel PWM interface (PWM0 to PWM5). The PWM outputs can be configured to drive an H-bridge or can be used as standard PWM outputs. On power-up, the PWM outputs default to H-bridge mode. This ensures that the motor is turned off by default. In standard PWM mode, the outputs are arranged as three pairs of PWM pins. The user has control over the period of each pair of outputs and over the duty cycle of each individual output.

**Table 112. PWM MMRs**

Name	Function
PWMCON0	PWM control.
PWM0COM0	Compare Register 0 for PWM Output 0 and PWM Output 1.
PWM0COM1	Compare Register 1 for PWM Output 0 and PWM Output 1.
PWM0COM2	Compare Register 2 for PWM Output 0 and PWM Output 1.
PWM0LEN	Frequency control for PWM Output 0 and PWM Output 1.
PWM1COM0	Compare Register 0 for PWM Output 2 and PWM Output 3.
PWM1COM1	Compare Register 1 for PWM Output 2 and PWM Output 3.
PWM1COM2	Compare Register 2 for PWM Output 2 and PWM Output 3.
PWM1LEN	Frequency control for PWM Output 2 and PWM Output 3.
PWM2COM0	Compare Register 0 for PWM Output 4 and Output 5
PWM2COM1	Compare Register 1 for PWM Output 4 and Output 5
PWM2COM2	Compare Register 2 for PWM Output 4 and Output 5
PWM2LEN	Frequency control for PWM Output 4 and PWM Output 5.
PWMCON1	PWM control register
PWMCLR1	PWM interrupt clear.

In all modes, the PWMxCOMx MMRs control the point at which the PWM outputs change state. An example of the first pair of PWM outputs (PWM0 and PWM1) is shown in Figure 49.

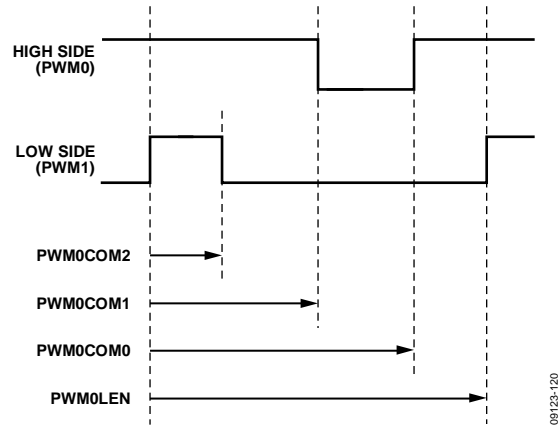

Figure 49. PWM Timing

The PWM clock is selectable via PWMCON with one of the following values: UCLK divided by 2, 4, 8, 16, 32, 64, 128, or 256. The length of a PWM period is defined by PWMxLEN.

The PWM waveforms are set by the count value of the 16-bit timer and the compare registers contents, as shown with the PWM0 and PWM1 waveforms in Figure 49.

The low-side waveform, PWM1, goes high when the timer count reaches PWM0LEN, and it goes low when the timer count reaches the value held in PWM0COM2 or when the high-side waveform (PWM0) goes low.

The high-side waveform, PWM0, goes high when the timer count reaches the value held in PWM0COM0, and it goes low when the timer count reaches the value held in PWM0COM1.

Table 113. PWMCON0 MMR Bit Descriptions

Bit	Name	Description
14	SYNC	Enables PWM synchronization. Set to 1 by the user so that all PWM counters are reset on the next clock edge after the detection of a high-to-low transition on the P3.7/PWM <sub>SYNC</sub> pin. Cleared by the user to ignore transitions on the P3.7/PWM <sub>SYNC</sub> pin.
13	PWM5INV	Set to 1 by the user to invert PWM5. Cleared by the user to use PWM5 in normal mode.
12	PWM3INV	Set to 1 by the user to invert PWM3. Cleared by the user to use PWM3 in normal mode.
11	PWM1INV	Set to 1 by the user to invert PWM1. Cleared by the user to use PWM1 in normal mode.
10	PWMTRIP	Set to 1 by the user to enable PWM trip interrupt. When the PWM trip input (Pin P3.6/PWM <sub>TRIP</sub> or Pin P0.4/PWM <sub>TRIP</sub> ) is low, the PWMEN bit is cleared and an interrupt is generated. Cleared by the user to disable the PWMTRIP interrupt.
9	ENA	If HOFF = 0 and HMODE = 1; note that, if not in H-bridge mode, this bit has no effect. Set to 1 by the user to enable PWM outputs. Cleared by the user to disable PWM outputs. If HOFF = 1 and HMODE = 1, see Table 114.
[8:6]	PWMCP[2:0]	PWM clock prescaler bits. Sets the UCLK divider. [000] = UCLK/2. [001] = UCLK/4. [010] = UCLK/8. [011] = UCLK/16. [100] = UCLK/32. [101] = UCLK/64. [110] = UCLK/128. [111] = UCLK/256.
5	POINV	Set to 1 by the user to invert all PWM outputs. Cleared by the user to use PWM outputs as normal.
4	HOFF	High side off. Set to 1 by the user to force PWM0 and PWM2 outputs high. This also forces PWM1 and PWM3 low. Cleared by the user to use the PWM outputs as normal.
3	LCOMP	Load compare registers. Set to 1 by the user to load the internal compare registers with the values in PWMxCOMx on the next transition of the PWM timer from 0x00 to 0x01. Cleared by the user to use the values previously stored in the internal compare registers.
2	DIR	Direction control. Set to 1 by the user to enable PWM0 and PWM1 as the output signals while PWM2 and PWM3 are held low. Cleared by the user to enable PWM2 and PWM3 as the output signals while PWM0 and PWM1 are held low.
1	HMODE	Enables H-bridge mode. <sup>1</sup> Set to 1 by the user to enable H-bridge mode and Bit 1 to Bit 5 of PWMCON. Cleared by the user to operate the PWMs in standard mode.
0	PWMEN	Set to 1 by the user to enable all PWM outputs. Cleared by the user to disable all PWM outputs.

<sup>1</sup> In H-bridge mode, HMODE = 1. See Table 114 to determine the PWM outputs.

Table 114. PWM Output Selection, HMODE = 1

PWMCON0 MMR <sup>1</sup>				PWM Outputs <sup>2</sup>			
ENA	HOFF	POINV	DIR	PWM0	PWM1	PWM2	PWM3
0	0	X	X	1	1	1	1
X	1	X	X	1	0	1	0
1	0	0	0	0	0	HS	LS
1	0	0	1	HS	LS	0	0
1	0	1	0	HS	LS	1	1
1	0	1	1	1	1	HS	LS

<sup>1</sup>X = don't care.  
<sup>2</sup>HS = high side, LS = low side.

On power-up, PWMCON0 defaults to 0x12 (HOFF = 1 and HMODE = 1). All GPIO pins associated with the PWM are configured in PWM mode by default (see Table 115).

Table 115. Compare Registers

Name	Address	Default Value	Access
PWM0COM0	0xFFFF0F84	0x0000	R/W
PWM0COM1	0xFFFF0F88	0x0000	R/W
PWM0COM2	0xFFFF0F8C	0x0000	R/W
PWM1COM0	0xFFFF0F94	0x0000	R/W
PWM1COM1	0xFFFF0F98	0x0000	R/W
PWM1COM2	0xFFFF0F9C	0x0000	R/W
PWM2COM0	0xFFFF0FA4	0x0000	R/W
PWM2COM1	0xFFFF0FA8	0x0000	R/W
PWM2COM2	0xFFFF0FAC	0x0000	R/W

The PWM trip interrupt can be cleared by writing any value to the PWMCLRI MMR. Note that, when using the PWM trip interrupt, users should make sure that the PWM interrupt has been cleared before exiting the ISR. This prevents generation of multiple interrupts.

**PWM Convert Start Control**

The PWM can be configured to generate an ADC convert start signal after the active low side signal goes high. There is a programmable delay between the time that the low-side signal goes high and the convert start signal is generated.

This is controlled via the PWMCON1 MMR. If the delay selected is higher than the width of the PWM pulse, the interrupt remains low.

Table 116. PWMCON1 MMR Bit Descriptions (Address = 0xFFFF0FB4; Default Value = 0x00)

Bit	Value	Name	Description
7		CSEN	Set to 1 by the user to enable the PWM to generate a convert start signal. Cleared by user to disable the PWM convert start signal.
[3:0]		CSD3 CSD2 CSD1 CSD0	Convert start delay. Delays the convert start signal by a number of clock pulses.
	0000		Four clock pulses.
	0001		Eight clock pulses.
	0010		12 clock pulses.
	0011		16 clock pulses.
	0100		20 clock pulses.
	0101		24 clock pulses.
	0110		28 clock pulses.
	0111		32 clock pulses.
	1000		36 clock pulses.
	1001		40 clock pulses.
	1010		44 clock pulses.
	1011		48 clock pulses.
	1100		52 clock pulses.
	1101		56 clock pulses.
	1110		60 clock pulses.
	1111		64 clock pulses.

When calculating the time from the convert start delay to the start of an ADC conversion, the user must take account of internal delays. The following example shows the case of a delay of four clocks. One additional clock is required to pass the convert start signal to the ADC logic. Once the ADC logic receives the convert start signal, an ADC conversion begins on the next ADC clock edge (see Figure 50).

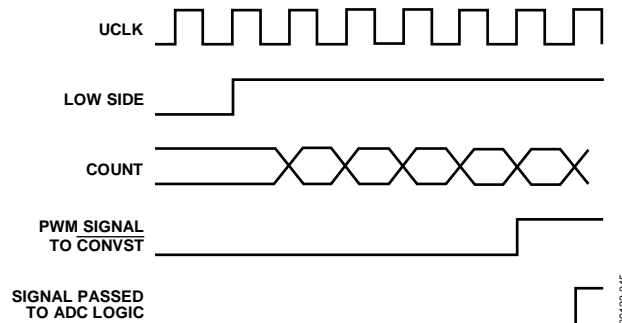

Figure 50. ADC Conversion

08123-045

## PROGRAMMABLE LOGIC ARRAY (PLA)

Every ADuC7124/ADuC7126 integrates a fully programmable logic array (PLA) that consists of two independent but interconnected PLA blocks. Each block consists of eight PLA elements, giving each part a total of 16 PLA elements.

Each PLA element contains a two-input look up table that can be configured to generate any logic output function based on two inputs and a flip-flop. This is represented in Figure 51.

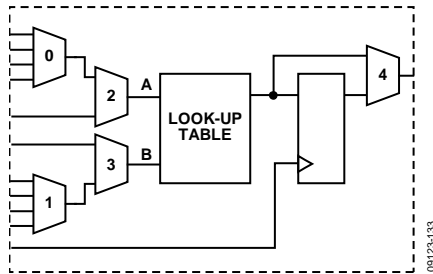

Figure 51. PLA Element

In total, 40 GPIO pins are available on the ADuC7124/ADuC7126 for the PLA. These include 16 input pins and 16 output pins that must be configured in the GPxCON register as PLA pins before using the PLA. Note that the comparator output is also included as one of the 16 input pins.

The PLA is configured via a set of user MMRs. The output(s) of the PLA can be routed to the internal interrupt system, to the CONV<sub>START</sub> signal of the ADC, to an MMR, or to any of the 16 PLA output pins.

The two blocks can be interconnected as follows:

- Output of Element 15 (Block 1) can be fed back to Input 0 of Mux 0 of Element 0 (Block 0).
- Output of Element 7 (Block 0) can be fed back to Input 0 of Mux 0 of Element 8 (Block 1).

Table 117. Element Input/Output<sup>1</sup>

PLA Block 0			PLA Block 1		
Element	Input	Output	Element	Input	Output
0	P1.0	P1.7	8	P3.0	P4.0
1	P1.1	P0.4	9	P3.1	P4.1
2	P1.2	P0.5	10	P3.2	P4.2
3	P1.3	P0.6	11	P3.3	P4.3
4	P1.4	P0.7	12	P3.4	P4.4
5	P1.5	P2.0	13	P3.5	P4.5
6	P1.6	P2.1	14	P3.6	P4.6
7	P0.0	P2.2	15	P3.7	P4.7

<sup>1</sup> Not all pins in this table are connected to external pins. However, they may be routed internally via the PLA. See Table 122 for further details.

## PLA MMRs Interface

The PLA peripheral interface consists of the 22 MMRs.

Table 118. PLAELMx Registers

Name	Address	Default Value	Access
PLAELM0	0xFFFF0B00	0x0000	R/W
PLAELM1	0xFFFF0B04	0x0000	R/W
PLAELM2	0xFFFF0B08	0x0000	R/W
PLAELM3	0xFFFF0B0C	0x0000	R/W
PLAELM4	0xFFFF0B10	0x0000	R/W
PLAELM5	0xFFFF0B14	0x0000	R/W
PLAELM6	0xFFFF0B18	0x0000	R/W
PLAELM7	0xFFFF0B1C	0x0000	R/W
PLAELM8	0xFFFF0B20	0x0000	R/W
PLAELM9	0xFFFF0B24	0x0000	R/W
PLAELM10	0xFFFF0B28	0x0000	R/W
PLAELM11	0xFFFF0B2C	0x0000	R/W
PLAELM12	0xFFFF0B30	0x0000	R/W
PLAELM13	0xFFFF0B34	0x0000	R/W
PLAELM14	0xFFFF0B38	0x0000	R/W
PLAELM15	0xFFFF0B3C	0x0000	R/W

The PLAELMx are Element 0 to Element 15 control registers. They configure the input and output mux of each element, select the function in the look up table, and bypass/use the flip-flop (see Table 119 and Table 122).

Table 119. PLAELMx MMR Bit Descriptions

Bit	Value	Description
[31:11]		Reserved.
[10:9]		Mux 0 control (see Table 122).
[8:7]		Mux 1 control (see Table 122).
6		Mux 2 control. Set by the user to select the output of Mux 0. Cleared by the user to select the bit value from PLADIN.
5		Mux 3 control. Set by the user to select the input pin of the particular element. Cleared by the user to select the output of Mux 1.
[4:1]		Look-up table control.
	0000	0.
	0001	NOR.
	0010	B AND NOT A.
	0011	NOT A.
	0100	A AND NOT B.
	0101	NOT B.
	0110	EXOR.
	0111	NAND.
	1000	AND.
	1001	EXNOR.
	1010	B.
	1011	NOT A OR B.
	1100	A.
	1101	A OR NOT B.
	1110	OR.
	1111	1.
0		Mux 4 control. Set by the user to bypass the flip-flop. Cleared by the user to select the flip-flop (cleared by default).

### PLACK Register

Name: PLACK  
 Address: 0xFFFF0B40  
 Default Value: 0x00  
 Access: Read/write

PLACK is the clock selection for the flip-flops of Block 0 and Block 1. Note that the maximum frequency when using the GPIO pins as the clock input for the PLA blocks is 41.78 MHz.

**Table 120. PLACK MMR Bit Descriptions**

Bit	Value	Description
7		Reserved.
[6:4]		Block 1 clock source selection.
	000	GPIO clock on P0.5.
	001	GPIO clock on P0.0.
	010	GPIO clock on P0.7.
	011	HCLK.
	100	OCLK (32.768 kHz).
	101	Timer1 overflow.
	110	UCLK.
	111	Internal 32,768 oscillator.
3		Reserved.
[2:0]		Block 0 clock source selection.
	000	GPIO clock on P0.5.
	001	GPIO clock on P0.0.
	010	GPIO clock on P0.7.
	011	HCLK.
	100	OCLK (32.768 kHz).
	101	Timer1 overflow.
	Other	Reserved.

### PLAIRQ Register

Name: PLAIRQ  
 Address: 0xFFFF0B44  
 Default Value: 0x00000000  
 Access: Read/write

PLAIRQ enables IRQ0 and/or IRQ1 and selects the source of the IRQ.

**Table 121. PLAIRQ MMR Bit Descriptions**

Bit	Value	Description
[15:13]		Reserved.
12		PLA IRQ1 enable bit. Set by the user to enable IRQ1 output from PLA. Cleared by the user to disable IRQ1 output from PLA.
[11:8]		PLA IRQ1 source.
	0000	PLA Element 0.
	0001	PLA Element 1.
	1111	PLA Element 15.
[7:5]		Reserved.
4		PLA IRQ0 enable bit. Set by the user to enable IRQ0 output from PLA. Cleared by the user to disable IRQ0 output from PLA.
[3:0]		PLA IRQ0 source.
	0000	PLA Element 0.
	0001	PLA Element 1.
	1111	PLA Element 15.

**Table 122. Feedback Configuration**

Bit	Value	PLAELM0	PLAELM1 to PLAELM7	PLAELM8	PLAELM9 to PLAELM15
[10:9]	00	Element 15	Element 0	Element 7	Element 8
	01	Element 2	Element 2	Element 10	Element 10
	10	Element 4	Element 4	Element 12	Element 12
	11	Element 6	Element 6	Element 14	Element 14
[8:7]	00	Element 1	Element 1	Element 9	Element 9
	01	Element 3	Element 3	Element 11	Element 11
	10	Element 5	Element 5	Element 13	Element 13
	11	Element 7	Element 7	Element 15	Element 15

**PLAADC Register**

Name: PLAADC  
 Address: 0xFFFF0B48  
 Default Value: 0x00000000  
 Access: Read/write

PLAADC is the PLA source for the ADC start conversion signal.

**Table 123. PLAADC MMR Bit Descriptions**

Bit	Value	Description
[31:5]		Reserved.
4		ADC start conversion enable bit. Set by the user to enable ADC start conversion from PLA. Cleared by the user to disable ADC start conversion from PLA.
[3:0]		ADC start conversion source.
	0000	PLA Element 0.
	0001	PLA Element 1.
	1111	PLA Element 15.

**PLADIN Register**

Name: PLADIN  
 Address: 0xFFFF0B4C  
 Default Value: 0x00000000  
 Access: Read/write

PLADIN is a data input MMR for PLA.

**Table 124. PLADIN MMR Bit Descriptions**

Bit	Description
[31:16]	Reserved.
[15:0]	Input bit to Element 15 to Element 0.

**PLADOUT Register**

Name: PLADOUT  
 Address: 0xFFFF0B50  
 Default Value: 0x00000000  
 Access: Read only

PLADOUT is a data output MMR for PLA. This register is always updated.

**Table 125. PLADOUT MMR Bit Descriptions**

Bit	Description
[31:16]	Reserved.
[15:0]	Output bit from Element 15 to Element 0.

**PLALCK Register**

Name: PLALCK  
 Address: 0xFFFF0B54  
 Default Value: 0x00  
 Access: Write only

PLALCK is a PLA lock option. Bit 0 is written only once. When set, it does not allow modification of any of the PLA MMRs, except PLADIN. A PLA tool is provided in the development system to easily configure the PLA.

## PROCESSOR REFERENCE PERIPHERALS

### INTERRUPT SYSTEM

There are 25 interrupt sources on the [ADuC7124/ADuC7126](#) that are controlled by the interrupt controller. All interrupts are generated from the on-chip peripherals, except for the software interrupt (SWI), which is programmable by the user. The ARM7TDMI CPU core recognizes interrupts as one of two types: a normal interrupt request (IRQ) and a fast interrupt request (FIQ). All the interrupts can be masked separately.

The control and configuration of the interrupt system is managed through a number of interrupt-related registers. The bits in each IRQ and FIQ register represent the same interrupt source as described in Table 126.

The [ADuC7124/ADuC7126](#) contain a vectored interrupt controller (VIC) that supports nested interrupts up to eight levels. The VIC also allows the programmer to assign priority levels to all interrupt sources. Interrupt nesting must be enabled by setting the ENIRQN bit in the IRQCONN register. A number of extra MMRs are used when the full-vectored interrupt controller is enabled.

IRQSTA/FIQSTA should be saved immediately upon entering the interrupt service routine (ISR) to ensure that all valid interrupt sources are serviced.

**Table 126. IRQ/FIQ MMRs Bit Descriptions**

Bit	Description	Comments
0	All interrupts OR'ed (FIQ only)	This bit is set if any FIQ is active.
1	Software interrupt	User programmable interrupt source.
2	Timer0	General-Purpose Timer 0.
3	Timer1	General-Purpose Timer 1.
4	Timer2 or wake-up timer	General-Purpose Timer 2 or wake-up timer.
5	Timer3 or watchdog timer	General-Purpose Timer 3 or watchdog timer.
6	Flash Control 0	Flash controller for Block 0 interrupt.
7	Flash Control 1	Flash controller for Block 1 interrupt.
8	ADC	ADC interrupt source bit.
9	UART0	UART0 interrupt source bit.
10	UART1	UART1 interrupt source bit.
11	PLL lock	PLL lock bit.
12	I2C0 master IRQ	I <sup>2</sup> C master interrupt source bit.
13	I2C0 slave IRQ	I <sup>2</sup> C slave interrupt source bit.
14	I2C1 master IRQ	I <sup>2</sup> C master interrupt source bit.
15	I2C1 slave IRQ	I <sup>2</sup> C slave interrupt source bit.
16	SPI	SPI interrupt source bit.
17	XIRQ0 (GPIO IRQ0)	External Interrupt 0.
18	Comparator	Voltage comparator source bit.
19	PSM	Power supply monitor.
20	XIRQ1 (GPIO IRQ1)	External Interrupt 1.

Bit	Description	Comments
21	PLA IRQ0	PLA Block 0 IRQ bit.
22	XIRQ2 (GPIO IRQ2)	External Interrupt 2.
23	XIRQ3 (GPIO IRQ3)	External Interrupt 3.
24	PLA IRQ1	PLA Block 1 IRQ bit.
25	PWM	PWM trip interrupt source bit.

### IRQ

The IRQ is the exception signal to enter the IRQ mode of the processor. It services general-purpose interrupt handling of internal and external events.

All 32 bits are logically OR'ed to create a single IRQ signal to the ARM7TDMI core. Descriptions of the four 32-bit registers dedicated to IRQ follow.

#### IRQSTA Register

IRQSTA is a read-only register that provides the current-enabled IRQ source status (effectively a logic AND of the IRQSIG and IRQEN bits). When set to 1, that source generates an active IRQ request to the ARM7TDMI core. There is no priority encoder or interrupt vector generation. This function is implemented in software in a common interrupt handler routine.

#### IRQSTA Register

Name:	IRQSTA
Address:	0xFFFF0000
Default Value:	0x00000000
Access:	Read only

#### IRQSIG Register

IRQSIG reflects the status of the various IRQ sources. If a peripheral generates an IRQ signal, the corresponding bit in the IRQSIG is set; otherwise, it is cleared. The IRQSIG bits clear when the interrupt in the particular peripheral is cleared. All IRQ sources can be masked in the IRQEN MMR. IRQSIG is read only. This register should not be used in an interrupt service routine for determining the source of an IRQ exception; IRQSTA should only be used for this purpose.

#### IRQSIG Register

Name:	IRQSIG
Address:	0xFFFF0004
Default Value:	0x00000000
Access:	Read only

**IRQEN Register**

IRQEN provides the value of the current enable mask. When a bit is set to 1, the corresponding source request is enabled to create an IRQ exception. When a bit is set to 0, the corresponding source request is disabled or masked, which does not create an IRQ exception. The IRQEN register cannot be used to disable an interrupt.

**IRQEN Register**

Name: IRQEN  
 Address: 0xFFFF0008  
 Default Value: 0x00000000  
 Access: Read/write

**IRQCLR Register**

IRQCLR is a write-only register that allows the IRQEN register to clear to mask an interrupt source. Each bit that is set to 1 clears the corresponding bit in the IRQEN register without affecting the remaining bits. The pair of registers, IRQEN and IRQCLR, allow independent manipulation of the enable mask without requiring an atomic read-modify-write.

This register should be used to disable an interrupt source only during the following conditions:

- In the interrupt sources interrupt service routine.
- When the peripheral is temporarily disabled by its own control register.

This register should not be used to disable an IRQ source if that IRQ source has an interrupt pending or may have an interrupt pending.

**IRQCLR Register**

Name: IRQCLR  
 Address: 0xFFFF000C  
 Default Value: 0x00000000  
 Access: Write only

**FAST INTERRUPT REQUEST (FIQ)**

The fast interrupt request (FIQ) is the exception signal to enter the FIQ mode of the processor. It is provided to service data transfer or communication channel tasks with low latency. The FIQ interface is identical to the IRQ interface and provides the second level interrupt (highest priority). Four 32-bit registers are dedicated to FIQ: FIQSIG, FIQEN, FIQCLR, and FIQSTA.

Bit 31 to Bit 1 of FIQSTA are logically ORed to create the FIQ signal to the core and to Bit 0 of both the FIQ and IRQ registers (FIQ source).

The logic for FIQEN and FIQCLR does not allow an interrupt source to be enabled in both IRQ and FIQ masks. A bit set to 1 in FIQEN clears, as a side effect, the same bit in IRQEN.

Likewise, a bit set to 1 in IRQEN clears, as a side effect, the same bit in FIQEN. An interrupt source can be disabled in both the IRQEN and FIQEN masks.

**FIQSIG**

FIQSIG reflects the status of the different FIQ sources. If a peripheral generates an FIQ signal, the corresponding bit in the FIQSIG is set; otherwise, it is cleared. The FIQSIG bits are cleared when the interrupt in the particular peripheral is cleared. All FIQ sources can be masked in the FIQEN MMR. FIQSIG is read only.

**FIQSIG Register**

Name: FIQSIG  
 Address: 0xFFFF0104  
 Default Value: 0x00000000  
 Access: Read only

**FIQEN**

FIQEN provides the value of the current enable mask. When a bit is set to 1, the corresponding source request is enabled to create an FIQ exception. When a bit is set to 0, the corresponding source request is disabled or masked, which does not create an FIQ exception. The FIQEN register cannot be used to disable an interrupt.

**FIQEN Register**

Name: FIQEN  
 Address: 0xFFFF0108  
 Default Value: 0x00000000  
 Access: Read/write

**FIQCLR**

FIQCLR is a write-only register that allows the FIQEN register to clear to mask an interrupt source. Each bit that is set to 1 clears the corresponding bit in the FIQEN register without affecting the remaining bits. The pair of registers, FIQEN and FIQCLR, allows independent manipulation of the enable mask without requiring an atomic read-modify-write.

This register should be used to disable an interrupt source only during the following conditions:

- In the interrupt sources interrupt service routine.
- The peripheral is temporarily disabled by its own control register.

This register should not be used to disable an IRQ source if that IRQ source has an interrupt pending or may have an interrupt pending.

**FIQCLR Register**

Name: FIQCLR  
 Address: 0xFFFF010C  
 Default Value: 0x00000000  
 Access: Write only

**FIQSTA**

FIQSTA is a read-only register that provides the current enabled FIQ source status (effectively a logic AND of the FIQSIG and FIQEN bits). When set to 1, that source generates an active FIQ request to the ARM7TDMI core. There is no priority encoder or interrupt vector generation. This function is implemented in software in a common interrupt handler routine.

**FIQSTA Register**

Name: FIQSTA  
 Address: 0xFFFF0100  
 Default Value: 0x00000000  
 Access: Read only

**Programmed Interrupts**

Because the programmed interrupts are not maskable, they are controlled by another register (SWICFG) that writes into the IRQSTA and IRQSIG registers and/or the FIQSTA and FIQSIG registers at the same time.

The 32-bit register dedicated to software interrupt is SWICFG (described in Table 127). This MMR allows control of a programmed source interrupt.

**Table 127. SWICFG MMR Bit Descriptions**

Bit	Description
[31:3]	Reserved.
2	Programmed interrupt FIQ. Setting/clearing this bit corresponds to setting/clearing Bit 1 of FIQSTA and FIQSIG.
1	Programmed interrupt IRQ. Setting/clearing this bit corresponds to setting/clearing Bit 1 of IRQSTA and IRQSIG.
0	Reserved.

Any interrupt signal must be active for at least the minimum interrupt latency time to be detected by the interrupt controller and to be detected by the user in the IRQSTA/FIQSTA register.

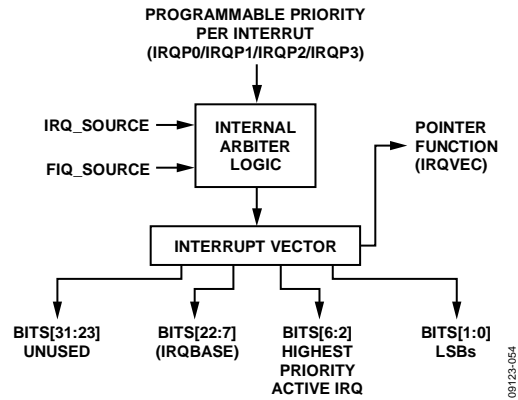

Figure 52. Interrupt Structure

**VECTORED INTERRUPT CONTROLLER (VIC)**

The ADuC7124/ADuC7126 incorporate an enhanced interrupt control system or (vectored interrupt controller). The vectored interrupt controller for IRQ interrupt sources is enabled by setting Bit 0 of the IRQCONN register. Similarly, Bit 1 of IRQCONN enables the vectored interrupt controller for the FIQ interrupt sources. The vectored interrupt controller provides the following enhancements to the standard IRQ/FIQ interrupts:

- Vectored interrupts—allows a user to define separate interrupt service routine addresses for every interrupt source. This is achieved by using the IRQBASE and IRQVEC registers.
- IRQ/FIQ interrupts—can be nested up to eight levels depending on the priority settings. An FIQ still has a higher priority than an IRQ. Therefore, if the VIC is enabled for both the FIQ and IRQ and prioritization is maximized, it is possible to have 16 separate interrupt levels.
- Programmable interrupt priorities—using the IRQP0 to IRQP3 registers, an interrupt source can be assigned an interrupt priority level value between 0 and 7.

**VIC MMRs**

**IRQBASE Register**

The vector base register, IRQBASE, is used to point to the start address of memory used to store 32 pointer addresses. These pointer addresses are the addresses of the individual interrupt service routines.

Name: IRQBASE  
 Address: 0xFFFF0014  
 Default Value: 0x00000000  
 Access: Read/write

**Table 128. IRQBASE MMR Bit Descriptions**

Bit	Type	Initial Value	Description
[31:16]	Read only	Reserved	Always read as 0.
[15:0]	R/W	0	Vector base address.

**IRQVEC Register**

The IRQ interrupt vector register, IRQVEC points to a memory address containing a pointer to the interrupt service routine of the currently active IRQ. This register should only be read when an IRQ occurs and IRQ interrupt nesting has been enabled by setting Bit 0 of the IRQCONN register.

Name: IRQVEC  
 Address: 0xFFFF001C  
 Default Value: 0x00000000  
 Access: Read only

**Table 129. IRQVEC MMR Bit Descriptions**

Bit	Type	Initial Value	Description
[31:23]	R	0	Always read as 0.
[22:7]	R/W	0	IRQBASE register value.
[6:2]	R	0	Highest priority source. This is a value between 0 and 27 representing the possible interrupt sources. For example, if the highest currently active IRQ is Timer 2, then these bits are [00100].
[1:0]	Reserved	0	Reserved bits.

**Priority Registers**

The IRQ interrupt vector register, IRQVEC points to a memory address containing a pointer to the interrupt service routine of the currently active IRQ. This register should only be read when an IRQ occurs and IRQ interrupt nesting has been enabled by setting Bit 0 of the IRQCONN register.

**IRQP0 Register**

Name: IRQP0  
 Address: 0xFFFF0020  
 Default Value: 0x00000000  
 Access: Read/write

**Table 130. IRQP0 MMR Bit Descriptions**

Bit	Name	Description
31		Reserved.
[30:28]	Flash1PI	A priority level of 0 to 7 can be set for the Flash Block 1 controller interrupt source.
27		Reserved.
[26:24]	Flash0PI	A priority level of 0 to 7 can be set for the Flash Block 0 controller interrupt source.
23		Reserved.
[22:20]	T3PI	A priority level of 0 to 7 can be set for Timer 3.
19		Reserved.

Bit	Name	Description
[18:16]	T2PI	A priority level of 0 to 7 can be set for Timer2.
15		Reserved.
[14:12]	T1PI	A priority level of 0 to 7 can be set for Timer1.
11		Reserved.
[10:8]	T0PI	A priority level of 0 to 7 can be set for Timer0.
7		Reserved.
[6:4]	SWINTP	A priority level of 0 to 7 can be set for the software interrupt source.
[3:0]		Interrupt 0 cannot be prioritized.

**IRQP1 Register**

Name: IRQP1  
 Address: 0xFFFF0024  
 Default Value: 0x00000000  
 Access: Read/write

**Table 131. IRQP1 MMR Bit Descriptions**

Bit	Name	Description
31		Reserved.
[30:28]	I2C1SPI	A priority level of 0 to 7 can be set for the I2C1 slave.
27		Reserved.
[26:24]	I2C1MPI	A priority level of 0 to 7 can be set for the I2C1 master.
23		Reserved.
[22:20]	I2C0SPI	A priority level of 0 to 7 can be set for the I2C0 slave.
19		Reserved.
[18:16]	I2C0MPI	A priority level of 0 to 7 can be set for the I <sup>2</sup> C 0 master.
15		Reserved.
[14:12]	PLLPI	A priority level of 0 to 7 can be set for the PLL lock interrupt.
11		Reserved.
[10:8]	UART1PI	A priority level of 0 to 7 can be set for UART1.
7		Reserved.
[6:4]	UART0PI	A priority level of 0 to 7 can be set for UART0.
5		Reserved.
[2:0]	ADCPI	A priority level of 0 to 7 can be set for the ADC interrupt source.

**IRQP2 Register**

Name: IRQP2  
 Address: 0xFFFF0028  
 Default Value: 0x00000000  
 Access: Read/write

**Table 132. IRQP2 MMR Bit Descriptions**

Bit	Name	Description
31		Reserved.
[30:28]	IRQ3PI	A priority level of 0 to 7 can be set for IRQ3.
27		Reserved.
[26:24]	IRQ2PI	A priority level of 0 to 7 can be set for IRQ2.
23		Reserved.
[22:20]	PLA0PI	A priority level of 0 to 7 can be set for PLA IRQ0.
19		Reserved.
[18:16]	IRQ1PI	A priority level of 0 to 7 can be set for IRQ1.
15		Reserved.
[14:12]	PSMPI	A priority level of 0 to 7 can be set for the power supply monitor interrupt source.
11		Reserved.
[10:8]	COMPI	A priority level of 0 to 7 can be set for the comparator.
7		Reserved.
[6:4]	IRQ0PI	A priority level of 0 to 7 can be set for IRQ0.
3		Reserved.
[2:0]	SPIPI	A priority level of 0 to 7 can be set for SPI.

**IRQP3 Register**

Name: IRQP3  
 Address: 0xFFFF002C  
 Default Value: 0x00000000  
 Access: Read/write

**Table 133. IRQP3 MMR Bit Descriptions**

Bit	Name	Description
[31:7]		Reserved.
[6:4]	PWMPI	A priority level of 0 to 7 can be set for PWM.
3		Reserved.
[2:0]	PLA1PI	A priority level of 0 to 7 can be set for PLA IRQ1.

**IRQCONN Register**

The IRQCONN register is the IRQ and FIQ control register. It contains two active bits: the first to enable nesting and prioritization of IRQ interrupts and the other to enable nesting and prioritization of FIQ interrupts.

If these bits are cleared, FIQs and IRQs can still be used, but it is not possible to nest IRQs or FIQs, nor is it possible to set an

interrupt source priority level. In this default state, an FIQ does have a higher priority than an IRQ.

Name: IRQCONN  
 Address: 0xFFFF0030  
 Default Value: 0x00000000  
 Access: Read/write

**Table 134. IRQCONN MMR Bit Descriptions**

Bit	Name	Description
31:2		Reserved. These bits are reserved and should not be written to.
1	ENFIQN	Setting this bit to 1 enables nesting of FIQ interrupts. Clearing this bit means no nesting or prioritization of FIQs is allowed.
0	ENIRQN	Setting this bit to 1 enables nesting of IRQ interrupts. Clearing this bit means no nesting or prioritization of IRQs is allowed.

**IRQSTAN Register**

If IRQCONN Bit 0 is asserted and IRQVEC is read, one of the IRQSTAN[7:0] bits is asserted. The bit that asserts depends on the priority of the IRQ. If the IRQ is of Priority 0, then Bit 0 asserts, if Priority 1, then Bit 1 asserts, and so on. When a bit is set in this register, all interrupts of that priority and lower are blocked.

To clear a bit in this register, all bits of a higher priority must be cleared first. It is only possible to clear one bit at a time. For example, if this register is set to 0x09, writing 0xFF changes the register to 0x08, and writing 0xFF a second time changes the register to 0x00.

Name: IRQSTAN  
 Address: 0xFFFF003C  
 Default Value: 0x00000000  
 Access: Read/write

**Table 135. IRQSTAN MMR Bit Descriptions**

Bit	Name	Description
31:8		Reserved. These bits are reserved and should not be written to.
7:0		Setting these bits to 1 enables nesting of FIQ interrupts. Clearing these bits means no nesting or prioritization of FIQs is allowed.

**FIQVEC Register**

The FIQ interrupt vector register, FIQVEC, points to a memory address containing a pointer to the interrupt service routine of the currently active FIQ. This register should be read only when an FIQ occurs and FIQ interrupt nesting has been enabled by setting Bit 1 of the IRQCONN register.

Name: FIQVEC  
 Address: 0xFFFF011C  
 Default Value: 0x00000000  
 Access: Read only

**Table 136. FIQVEC MMR Bit Descriptions**

Bit	Type	Initial Value	Description
[31:23]	R	0	Always read as 0.
[22:7]	R/W	0	IRQBASE register value.
[6:2]		0	Highest priority source. This is a value between 0 and 27, representing the currently active interrupt source. The interrupts are listed in Table 126. For example, if the highest currently active FIQ is Timer2, then these bits are [00100].
[1:0]		0	Reserved.

**FIQSTAN Register**

If IRQCONN Bit 1 is asserted and FIQVEC is read, one of the FIQSTAN[7:0] bits is asserted. The bit that asserts depends on the priority of the FIQ. If the FIQ is of Priority 0, Bit 0 asserts, if Priority 1, Bit 1 asserts, and so forth.

When a bit is set in this register all interrupts of that priority and lower are blocked.

To clear a bit in this register, all bits of a higher priority must be cleared first. It is possible to clear only one bit at a time. For example, if this register is set to 0x09, then writing 0xFF

changes the register to 0x08 and writing 0xFF a second time changes the register to 0x00.

Name: FIQSTAN  
 Address: 0xFFFF013C  
 Default Value: 0x00000000  
 Access: Read/write

**Table 137. FIQSTAN MMR Bit Descriptions**

Bit	Name	Description
31:8		Reserved. These bits are reserved and should not be written to.
7:0		Setting this bit to 1 enables nesting of FIQ interrupts. Clearing this bit means no nesting or prioritization of FIQs is allowed.

**External Interrupts and PLA interrupts**

The ADuC7124/ADuC7126 provide up to four external interrupt sources and two PLA interrupt sources. These external interrupts can be individually configured as level or rising/falling edge triggered.

To enable the external interrupt source or the PLA interrupt source, the appropriate bit must first be set in the FIQEN or IRQEN register. To select the required edge or level to trigger on, the IRQCONE register must be appropriately configured.

To properly clear an edge-based external IRQ interrupt or an edge-based PLA interrupt, set the appropriate bit in the IRQCLRE register.

**IRQCONE Register**

Name: IRQCONE  
 Address: 0xFFFF0034  
 Default Value: 0x00000000  
 Access: Read/write

**Table 138. IRQCONE MMR Bit Descriptions**

Bit	Value	Name	Description
[31:12]			Reserved. These bits are reserved and should not be written to.
[11:10]	11 10 01 00	PLA1SRC[1:0]	PLA IRQ1 triggers on falling edge. PLA IRQ1 triggers on rising edge. PLA IRQ1 triggers on low level. PLA IRQ1 triggers on high level.
[9:8]	11 10 01 00	IRQ3SRC[1:0]	External IRQ3 triggers on falling edge. External IRQ3 triggers on rising edge. External IRQ3 triggers on low level. External IRQ3 triggers on high level.

Bit	Value	Name	Description
[7:6]	11 10 01 00	IRQ2SRC[1:0]	External IRQ2 triggers on falling edge. External IRQ2 triggers on rising edge. External IRQ2 triggers on low level. External IRQ2 triggers on high level.
[5:4]	11 10 01 00	PLA0SRC[1:0]	PLA IRQ0 triggers on falling edge. PLA IRQ0 triggers on rising edge. PLA IRQ0 triggers on low level. PLA IRQ0 triggers on high level.
[3:2]	11 10 01 00	IRQ1SRC[1:0]	External IRQ1 triggers on falling edge. External IRQ1 triggers on rising edge. External IRQ1 triggers on low level. External IRQ1 triggers on high level.
[1:0]	11 10 01 00	IRQ0SRC[1:0]	External IRQ0 triggers on falling edge. External IRQ0 triggers on rising edge. External IRQ0 triggers on low level. External IRQ0 triggers on high level.

**IRQCLRE Register**

Name:	IRQCLRE
Address:	0xFFFF0038
Default Value:	0x00000000
Access:	Write only

**Table 139. IRQCLRE MMR Bit Descriptions**

Bit	Name	Description
[31:25]		Reserved. These bits are reserved and should not be written to.
24	PLA1CLRI	A 1 must be written to this bit in the PLA IRQ1 interrupt service routine to clear an edge-triggered PLA IRQ1 interrupt.
23	IRQ3CLRI	A 1 must be written to this bit in the external IRQ3 interrupt service routine to clear an edge-triggered IRQ3 interrupt.
22	IRQ2CLRI	A 1 must be written to this bit in the external IRQ2 interrupt service routine to clear an edge-triggered IRQ2 interrupt.
21	PLA0CLRI	A 1 must be written to this bit in the PLA IRQ0 interrupt service routine to clear an edge-triggered PLA IRQ0 interrupt.
20	IRQ1CLRI	A 1 must be written to this bit in the external IRQ1 interrupt service routine to clear an edge-triggered IRQ1 interrupt.
[19:18]		Reserved. These bits are reserved and should not be written to.
17	IRQ0CLRI	A 1 must be written to this bit in the external IRQ0 interrupt service routine to clear an edge-triggered IRQ0 interrupt.
[16:0]		Reserved. These bits are reserved and should not be written to.

**TIMERS**

The ADuC7124/ADuC7126 have four general-purpose timers/counters.

- Timer0
- Timer1
- Timer2 or wake-up timer
- Timer3 or watchdog timer

These four timers in their normal mode of operation can be either free running or periodic.

In free-running mode, the counter decreases from the maximum value until zero scale is reached and starts again at the minimum value. It also increases from the minimum value until full scale is reached and starts again at the maximum value.

In periodic mode, the counter decrements/increments from the value in the load register (TxLD MMR) until zero/full scale is reached and starts again at the value stored in the load register.

The timer interval is calculated as follows:

If the timer is set to count down, then

$$Interval = \frac{(TxLD) \times Prescaler}{Source\ Clock}$$

If the timer is set to count up, then

$$Interval = \frac{(FullScale - TxLD) \times Prescaler}{Source\ Clock}$$

The value of a counter can be read at any time by accessing its value register (TxVAL). Note that, when a timer is being clocked from a clock other than a core clock, an incorrect value may be read (due to asynchronous clock system). In this configuration, TxVAL should always be read twice. If the two readings are different, it should be read a third time to obtain the correct value.

Timers are started by writing in the control register of the corresponding timer (TxCON).

In normal mode, an IRQ is generated each time the value of the counter reaches zero when counting down. It is also generated each time the counter value reaches full scale when counting up. An IRQ can be cleared by writing any value to clear the register of that particular timer (TxCLRI).

When using an asynchronous clock-to-clock timer, the interrupt in the timer block can take more time to clear than the time it takes for the code in the interrupt routine to execute. Ensure that the interrupt signal is cleared before leaving the interrupt service routine. This can be done by checking the IRQSTA MMR.

**Hr: Min: Sec: 1/128 Format**

Timer 1 and Timer 2 have an Hr: Min: Sec: hundreds format. To use the timer in Hr: Min: Sec: hundreds format, the 32768 kHz clock and prescaler of 256 should be selected. The hundreds field does not represent milliseconds, but 1/128 of a second (256/32768). The bits representing the hour, minute, and second are not consecutive in the register. This arrangement applies to TxLD and TxVAL when using the Hr: Min: Sec: hundreds format as set in TxCON[5:4]. See Table 140 for more details.

**Table 140. Hr: Min: Sec: Hundreds Format**

Bit	Value	Description
[31:24]	0 to 23 or 0 to 255	hours
[23:22]	0	reserved
[21:16]	0 to 59	minutes
[15:14]	0	reserved
[13:8]	0 to 59	seconds
7	0	reserved
[6:0]	0 to 127	1/128 of second

## Timer0 (RTOS Timer)

Timer0 is a general-purpose, 16-bit timer (count down) with a programmable prescaler. The prescaler source is the core clock frequency (HCLK) and can be scaled by a factor of 1, 16, or 256.

Timer0 can be used to start ADC conversions, as shown in the block diagram in Figure 53.

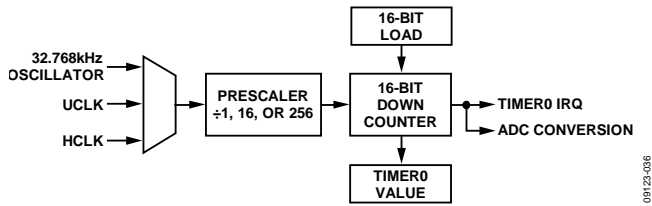

Figure 53. Timer0 Block Diagram

The Timer0 interface consists of four MMRs: TOLD, T0VAL, T0CON, and T0CLRI.

### TOLD Register

Name: TOLD  
 Address: 0xFFFF0300  
 Default Value: 0x0000  
 Access: Read/write

TOLD is a 16-bit load register.

### T0VAL Register

Name: T0VAL  
 Address: 0xFFFF0304  
 Default Value: 0xFFFF  
 Access: Read only

T0VAL is a 16-bit read-only register representing the current state of the counter.

### T0CON Register

Name: T0CON  
 Address: 0xFFFF0308  
 Default Value: 0x0000  
 Access: Read/write

T0CON is the configuration MMR described in Table 141.

**Table 141. T0CON MMR Bit Descriptions**

Bit	Value	Description
[31:8]		Reserved.
7		Timer0 enable bit. Set by the user to enable Timer0. Cleared by the user to disable Timer0 by default.
6		Timer0 mode. Set by the user to operate in periodic mode. Cleared by the user to operate in free-running mode. Default mode.
[5:4]		Clock select bits.
	00	HCLK.
	01	UCLK.
	10	32.768 kHz.
	11	Reserved.
[3:2]		Prescale.
	00	Core clock/1. Default value.
	01	Core clock/16.
	10	Core clock/256.
	11	Undefined. Equivalent to 00.
[1:0]		Reserved.

**T0CLRI Register**

Name: T0CLRI  
 Address: 0xFFFF030C  
 Default Value: 0xFF  
 Access: Write only

T0CLRI is an 8-bit register. Writing any value to this register clears the interrupt.

**Timer1 (General-Purpose Timer)**

Timer1 is a general-purpose, 32-bit timer (count down or count up) with a programmable prescaler. The source can be the 32 kHz external crystal, the undivided system, the core clock, or P1.1 (maximum frequency 41.78 MHz). This source can be scaled by a factor of 1, 16, 256, or 32,768.

The counter can be formatted as a standard 32-bit value or as hours: minutes: seconds: hundredths.

Timer1 has a capture register (T1CAP) that can be triggered by a selected IRQ source initial assertion. This feature can be used to determine the assertion of an event more accurately than the precision allowed by the RTOS timer when the IRQ is serviced.

Timer1 can be used to start ADC conversions.

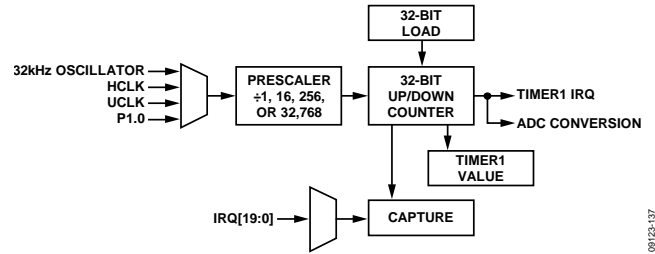

Figure 54. Timer1 Block Diagram

The Timer1 interface consists of five MMRs: T1LD, T1VAL, T1CON, T1CLRI, and T1CAP.

**T1LD Register**

Name: T1LD  
 Address: 0xFFFF0320  
 Default Value: 0x00000000  
 Access: Read/write

T1LD is a 32-bit load register.

**T1VAL Register**

Name: T1VAL  
 Address: 0xFFFF0324  
 Default Value: 0xFFFFFFFF  
 Access: Read only

T1VAL is a 32-bit read-only register that represents the current state of the counter.

**T1CON Register**

Name: T1CON  
 Address: 0xFFFF0328  
 Default Value: 0x0000  
 Access: Read/write

T1CON is the configuration MMR described in Table 142.

Table 142. T1CON MMR Bit Descriptions

Bit	Value	Description
[31:18]		Reserved.
17		Event select bit. Set by user to enable time capture of an event. Cleared by the user to disable time capture of an event.
[16:12]		Event select range, 0 to 25. These events are as described in Table 126. All events are offset by two, that is, Event 2 in Table 126 becomes Event 0 for the purposes of Timer0.
[11:9]		Clock select.
	000	Core clock (41 MHz/2 <sup>CD</sup> ).
	001	32.768 kHz.
	010	UCLK.
	011	P1.0 raising edge triggered.
8		Count up. Set by the user for Timer1 to count up. Cleared by the user for Timer1 to count down by default.
7		Timer1 enable bit. Set by the user to enable Timer1. Cleared by the user to disable Timer1 by default.
6		Timer1 mode. Set by the user to operate in periodic mode. Cleared by the user to operate in free-running mode. Default mode.
[5:4]		Format.
	00	Binary.
	01	Reserved.
	10	Hr: min: sec: hundredths (23 hours to 0 hour).
	11	Hr: min: sec: hundredths (255 hours to 0 hour).
[3:0]		Prescale.
	0000	Source clock/1.
	0100	Source clock/16.
	1000	Source clock/256.
	1111	Source clock/32,768.

**T1CLRI Register**

Name: T1CLRI  
Address: 0xFFFF032C  
Default Value: 0xFF  
Access: Write only

T1CLRI is an 8-bit register. Writing any value to this register clears the Timer1 interrupt.

**T1CAP Register**

Name: T1CAP  
Address: 0xFFFF0330  
Default Value: 0x00000000  
Access: Read

T1CAP is a 32-bit register. It holds the value contained in T1VAL when a particular event occurs. This event must be selected in T1CON.

**Timer2 (Wake-Up Timer)**

Timer2 is a 32-bit wake-up timer, count down or count up, with a programmable prescaler. The prescaler is clocked directly from one of four clock sources, including the core clock (default selection), the internal 32.768 kHz oscillator, the external 32.768 kHz watch crystal, or the PLL undivided clock. The selected clock source can be scaled by a factor of 1, 16, 256, or 32,768. The wake-up timer continues to run when the core clock is disabled. This gives a minimum resolution of 22 ns when the core is operating at 41.78 MHz and with a prescaler of 1. Capture of the current timer value is enabled if the Timer2 interrupt is enabled via IRQEN[4] (see Table 126).

The counter can be formatted as a plain 32-bit value or as hours: minutes: seconds: hundredths.

Timer2 reloads the value from T2LD either when Timer2 overflows or immediately when T2CLRI is written.

The Timer2 interface consists of four MMRs, shown in Table 143.

Table 143. Timer2 Interface Registers

Register	Description
T2LD	32-bit register. Holds 32-bit unsigned integers.
T2VAL	32-bit register. Holds 32-bit unsigned integers. This register is read only.
T2CLRI	8-bit register. Writing any value to this register clears the Timer2 interrupt.
T2CON	Configuration MMR.

**Timer2 Load Registers**

Name: T2LD  
Address: 0xFFFF0340  
Default Value: 0x00000  
Access: Read/write

T2LD is a 32-bit register, which holds the 32-bit value that is loaded into the counter.

**Timer2 Clear Register**

Name: T2CLR1  
 Address: 0xFFFF034C  
 Default Value: 0x00  
 Access: Write only

This 8-bit write-only MMR is written (with any value) by user code to refresh (reload) Timer2.

**Timer2 Value Register**

Name: T2VAL  
 Address: 0xFFFF0344  
 Default Value: 0x0000  
 Access: Read only

T2VAL is a 32-bit register that holds the current value of Timer2.

**Timer2 Control Register**

Name: T2CON  
 Address: 0xFFFF0348  
 Default Value: 0x0000  
 Access: Read/write

This 32-bit MMR configures the mode of operation for Timer2.

**Table 144. T2CON MMR Bit Descriptions**

Bit	Value	Description
[31:11]		Reserved.
10:9]		Clock source select.
	00	External 32.768 kHz watch crystal (default).
	01	External 32.768 kHz watch crystal.
	10	Internal 32.768 kHz oscillator.
	11	HCLK.
8		Count up. Set by the user for Timer2 to count up. Cleared by the user for Timer2 to count down (default).
7		Timer2 enable bit. Set by the user to enable Timer2. Cleared by the user to disable Timer2 (default).
6		Timer2 mode. Set by the user to operate in periodic mode. Cleared by the user to operate in free-running mode (default).
[5:4]		Format.
	00	Binary (default).
	01	Reserved.
	10	Hr: min: sec: hundredths (23 hours to 0 hours).
	11	Hr: min: sec: hundredths (255 hours to 0 hours).
[3:0]		Prescaler.
	0000	Source clock/1 (default).
	0100	Source clock/16.
	1000	Source clock/256.
	1111	Source clock/32,768.

**Timer3 (Watchdog Time)**

Timer3 has two modes of operation: normal mode and watchdog mode. The watchdog timer is used to recover from an illegal software state. Once enabled, it requires periodic servicing to prevent it from forcing a processor reset.

**Normal Mode**

Timer3 in normal mode is identical to Timer0, except for the clock source and the count-up functionality. The clock source is 32 kHz from the PLL and can be scaled by a factor of 1, 16, or 256 (see Figure 55).

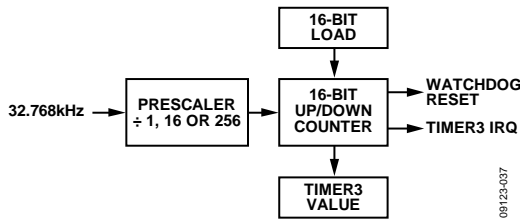

Figure 55. Timer3 Block Diagram

**Watchdog Mode**

Watchdog mode is entered by setting Bit 5 in the T3CON MMR. Timer3 decreases from the value present in the T3LD register until 0 is reached. T3LD is used as the timeout. The maximum timeout can be 512 sec using the prescaler/256 and full scale in T3LD. Timer3 is clocked by the internal 32 kHz crystal when operating in the watchdog mode. Note that, to enter watchdog mode successfully, Bit 5 in the T3CON MMR must be set after writing to the T3LD MMR.

If the timer reaches 0, a reset or an interrupt occurs, depending on Bit 1 in the T3CON register. To avoid reset or interrupt, any value must be written to T3CLR1 before the expiration period. This reloads the counter with T3LD and begins a new timeout period.

When watchdog mode is entered, T3LD and T3CON are write-protected. These two registers cannot be modified until a reset clears the watchdog enable bit, which causes Timer3 to exit watchdog mode.

The Timer3 interface consists of four MMRs: T3LD, T3VAL, T3CON, and T3CLR1.

**T3LD Register**

Name: T3LD  
 Address: 0xFFFF0360  
 Default Value: 0x0000  
 Access: Read/write

T3LD is a 16-bit load register.

**T3VAL Register**

Name: T3VAL  
 Address: 0xFFFF0364  
 Default Value: 0xFFFF  
 Access: Read only

T3VAL is a 16-bit read-only register that represents the current state of the counter.

**T3CON Register**

Name: T3CON  
 Address: 0xFFFF0368  
 Default Value: 0x0000  
 Access: Read/write

T3CON is the configuration MMR described in Table 145.

Table 145. T3CON MMR Bit Descriptions

Bit	Value	Description
[31:9]		Reserved.
8		Count up. Set by the user for Timer3 to count up. Cleared by the user for Timer3 to count down by default.
7		Timer3 enable bit. Set by the user to enable Timer3. Cleared by the user to disable Timer3 by default.
6		Timer3 mode. Set by the user to operate in periodic mode. Cleared by the user to operate in free-running mode (default mode).
5		Watchdog mode enable bit. Set by the user to enable watchdog mode. Cleared by the user to disable watchdog mode by default.
4		Secure clear bit. Set by the user to use the secure clear option. Cleared by the user to disable the secure clear option by default.
[3:2]		Prescale.
	00	Source clock/1 by default.
	01	Source clock/16.
	10	Source clock/256.
	11	Undefined. Equivalent to 00.
1		Watchdog IRQ option bit. Set by the user to produce an IRQ instead of a reset when the watchdog reaches 0. Cleared by the user to disable the IRQ option.
0		Reserved.

**T3CLRI Register**

Name:	T3CLRI
Address:	0xFFFF036C
Default Value:	0x00
Access:	Write only

T3CLRI is an 8-bit register. Writing any value to this register on successive occasions clears the Timer3 interrupt in normal mode or resets a new timeout period in watchdog mode.

Note that the user must perform successive writes to this register to ensure resetting the timeout period.

**Secure Clear Bit (Watchdog Mode Only)**

The secure clear bit is provided for a higher level of protection. When set, a specific sequential value must be written to T3CLRI to avoid a watchdog reset. The value is a sequence generated by the 8-bit linear feedback shift register (LFSR) polynomial =  $X^8 + X^6 + X^5 + X + 1$ , as shown in Figure 56.

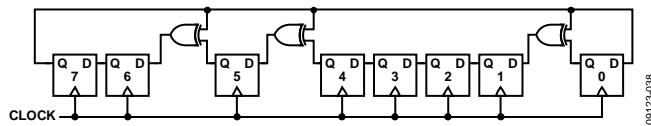

Figure 56. 8-Bit LFSR

The initial value or seed is written to T3CLRI before entering watchdog mode. After entering watchdog mode, a write to T3CLRI must match this expected value. If it matches, the LFSR is advanced to the next state when the counter reload occurs. If it fails to match the expected state, a reset is immediately generated, even if the count has not yet expired.

The value 0x00 should not be used as an initial seed due to the properties of the polynomial. The value 0x00 is always guaranteed to force an immediate reset. The value of the LFSR cannot be read; it must be tracked/generated in software.

Example of a sequence:

1. Enter initial seed, 0xAA, in T3CLRI before starting Timer3 in watchdog mode.
2. Enter 0xAA in T3CLRI; Timer3 is reloaded.
3. Enter 0x37 in T3CLRI; Timer3 is reloaded.
4. Enter 0x6E in T3CLRI; Timer3 is reloaded.
5. Enter 0x66. 0xDC was expected; the watchdog resets the chip.

**EXTERNAL MEMORY INTERFACING**

The ADuC7124/ADuC7126 feature an external memory interface. The external memory interface requires a larger number of pins. The XMCFG MMR must be set to 1 to use the external port.

Although 32-bit addresses are supported internally, only the lower 16 bits of the address are on external pins.

The memory interface can address up to four 128 kB of asynchronous memory (SRAM or/and EEPROM).

The pins required for interfacing to an external memory are shown in Table 146.

**Table 146. External Memory Interfacing Pins**

Pin	Function
AD[15:0]	Address/data bus.
A16	Extended addressing for 8-Bit memory only.
MS[3:0]	Memory select.
$\overline{WS}$	Write strobe.
$\overline{RS}$	Read strobe.
AE	Address latch enable.
$\overline{BHE}$ , $\overline{BLE}$	Byte write capability.

There are four external memory regions available as described in Table 147. Associated with each region are the MS[3:0] pins. These signals allow access to the particular region of external memory. The size of each memory region can be 128 kB maximum, 64 k × 16 or 128 kB × 8. To access 128 kB with an 8-bit memory, an extra address line (A16) is provided (see the example in Figure 57). The four regions are configured independently.

**Table 147. Memory Regions**

Address Start	Address End	Contents
0x10000000	0x1000FFFF	External Memory 0
0x20000000	0x2000FFFF	External Memory 1
0x30000000	0x3000FFFF	External Memory 2
0x40000000	0x4000FFFF	External Memory 3

Each external memory region can be controlled through three MMRs: XMCFG, XMxCON, and XMxPAR.

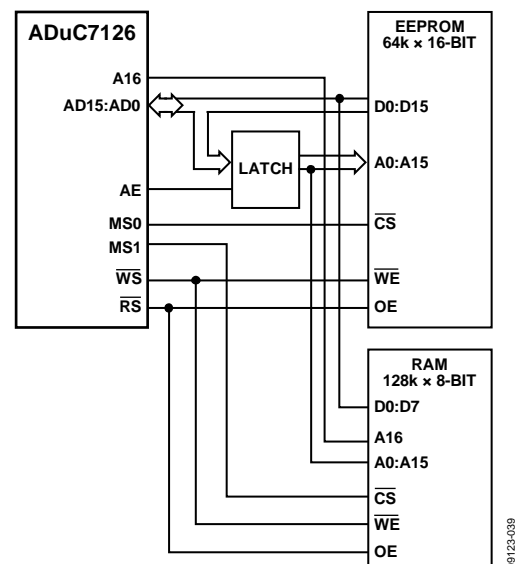

Figure 57. Interfacing to External EEPROM/RAM

**XMCFG Register**

Name:	XMCFG
Address:	0xFFFFF000
Default Value:	0x00
Access:	Read/write

XMCFG is set to 1 to enable external memory access. This must be set to 1 before any port pins can function as external memory access pins. The port pins must also be individually enabled via the GPxCON MMR.

**Table 148. XMxCON Registers**

Name	Address	Default Value	Access
XM0CON	0xFFFFF010	0x00	R/W
XM1CON	0xFFFFF014	0x00	R/W
XM2CON	0xFFFFF018	0x00	R/W
XM3CON	0xFFFFF01C	0x00	R/W

XMxCON are the control registers for each memory region. They allow the enabling/disabling of a memory region and control the data bus width of the memory region.

**Table 149. XMxCON MMR Bit Descriptions**

Bit	Description
1	Selects data bus width. Set by the user to select a 16-bit data bus. Cleared by the user to select an 8-bit data bus.
0	Enables memory region. Set by the user to enable memory region. Cleared by the user to disable the memory region.

**Table 150. XMxPAR Registers**

Name	Address	Default Value	Access
XM0PAR	0xFFFFF020	0x70FF	R/W
XM1PAR	0xFFFFF024	0x70FF	R/W
XM2PAR	0xFFFFF028	0x70FF	R/W
XM3PAR	0xFFFFF02C	0x70FF	R/W

XMxPAR are registers that define the protocol used for accessing the external memory for each memory region.

**Table 151. XMxPAR MMR Bit Descriptions**

Bit	Description
15	Enable byte write strobe. This bit is only used for two 8-bit memory blocks sharing the same memory region. Set by the user to gate the A0 output with the $\overline{WS}$ output. This allows byte write capability without using BHE and BLE signals. Cleared by user to use $\overline{BHE}$ and $\overline{BLE}$ signals.
[14:12]	Number of wait states on the address latch enable strobe.
11	Reserved.
10	Extra address hold time. Set by the user to disable extra hold time. Cleared by the user to enable one clock cycle of hold on the address in read and write.
9	Extra bus transition time on read. Set by the user to disable extra bus transition time. Cleared by the user to enable one extra clock before and after the read strobe ( $\overline{RS}$ ).
8	Extra bus transition time on write. Set by the user to disable extra bus transition time. Cleared by the user to enable one extra clock before and after the write strobe ( $\overline{WS}$ ).
[7:4]	Number of write wait states. Select the number of wait states added to the length of the $\overline{WS}$ pulse. 0x0 is 1 clock; 0xF is 16 clock cycles (default value).
[3:0]	Number of read wait states. Select the number of wait states added to the length of the $\overline{RS}$ pulse. 0x0 is 1 clock; 0xF is 16 clock cycles (default value).

Figure 58, Figure 59, Figure 60, and Figure 61 show the timing for a read cycle, a read cycle with address hold and bus turn cycles, a write cycle with address and write hold cycles, and a write cycle with wait states, respectively.

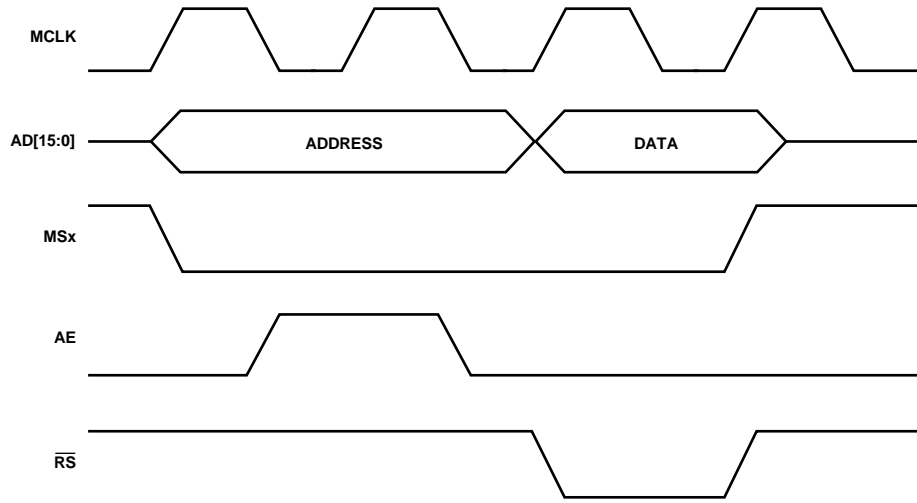

Figure 58. External Memory Read Cycle

09123-040

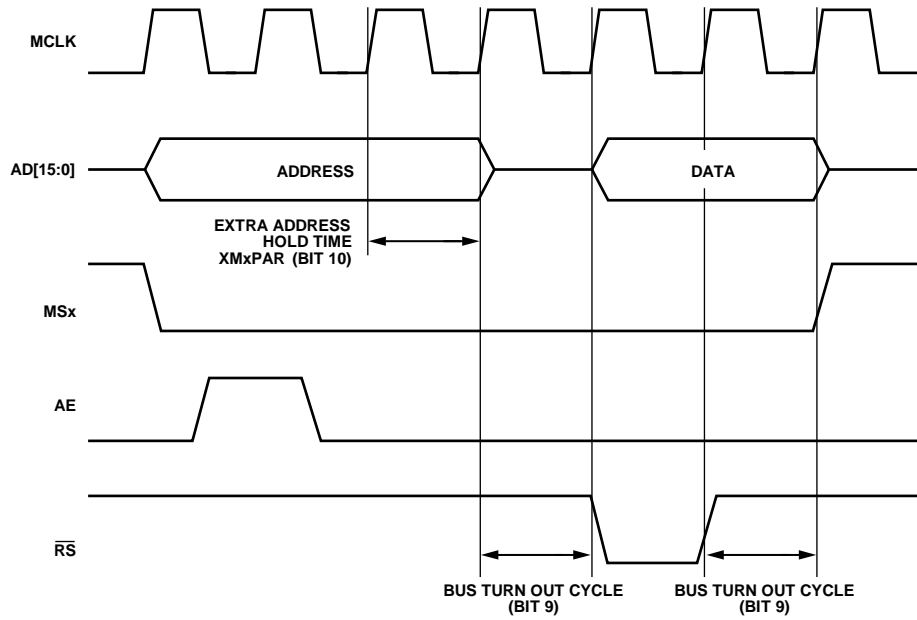

Figure 59. External Memory Read Cycle with Address Hold and Bus Turn Cycles

09123-041

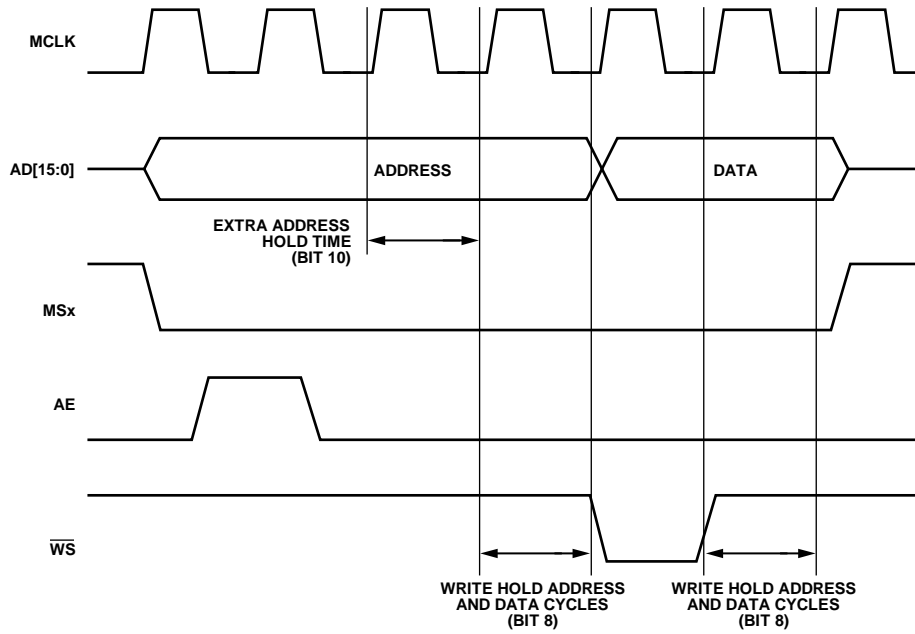

Figure 60. External Memory Write Cycle with Address and Write Hold Cycles

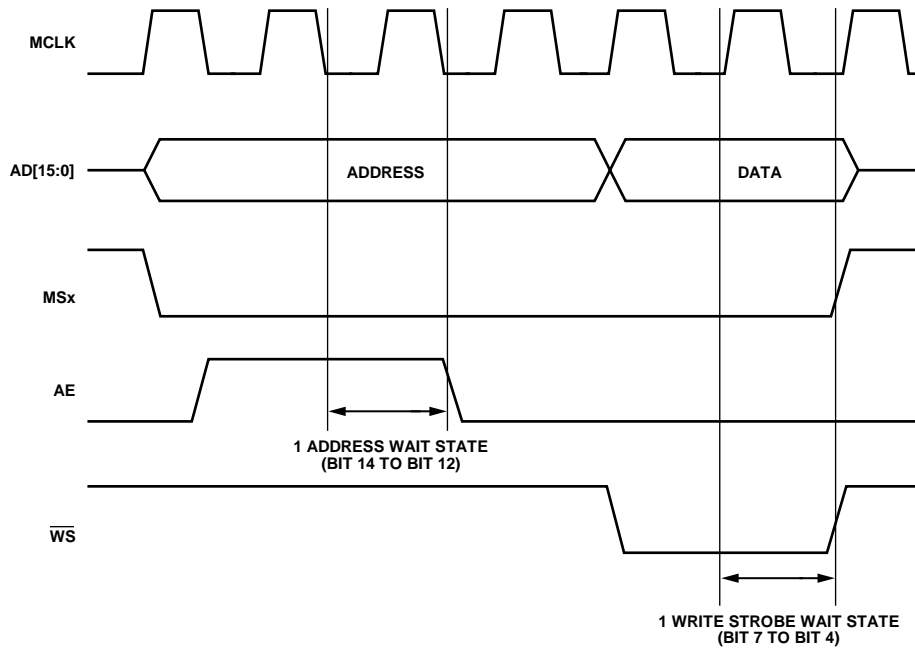

Figure 61. External Memory Write Cycle with Wait States

## HARDWARE DESIGN CONSIDERATIONS

### POWER SUPPLIES

The ADuC7124/ADuC7126 operational power supply voltage range is 2.7 V to 3.6 V. Separate analog and digital power supply pins ( $AV_{DD}$  and  $IOV_{DD}$ , respectively) allow  $AV_{DD}$  to be kept relatively free of noisy digital signals often present on the system  $IOV_{DD}$  line. In this mode, the part can also operate with split supplies; that is, it can use different voltage levels for each supply. For example, the system can be designed to operate with an  $IOV_{DD}$  voltage level of 3.3 V while the  $AV_{DD}$  level can be at 3 V or vice versa. A typical split supply configuration is shown in Figure 62.

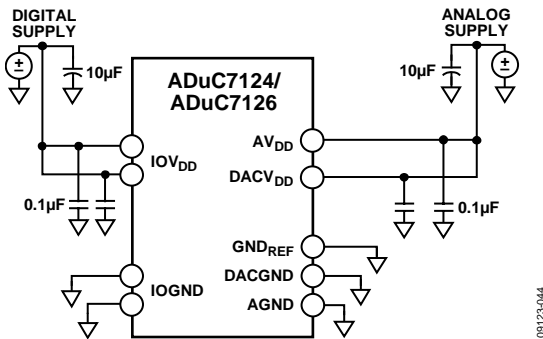

Figure 62. External Dual Supply Connections

As an alternative to providing two separate power supplies, the user can reduce noise on  $AV_{DD}$  by placing a small series resistor and/or ferrite bead between  $AV_{DD}$  and  $IOV_{DD}$  and then decoupling  $AV_{DD}$  separately to ground. An example of this configuration is shown in Figure 63. With this configuration, other analog circuitry (such as op amps, voltage reference, or any other analog circuitry) can be powered from the  $AV_{DD}$  supply line as well.

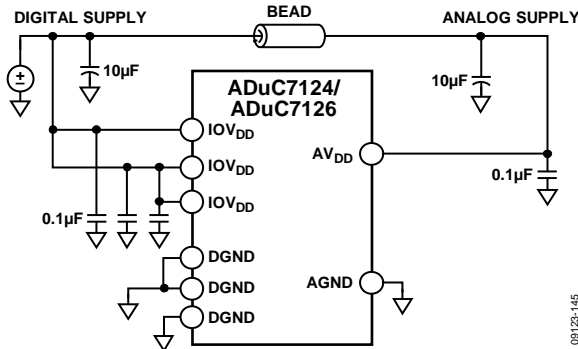

Figure 63. External Single Supply Connections

Notice that in both Figure 62 and Figure 63, a large value (10 µF) reservoir capacitor sits on  $IOV_{DD}$ , and a separate 10 µF capacitor sits on  $AV_{DD}$ . In addition, local small-value (0.1 µF) capacitors are located at each  $AV_{DD}$  and  $IOV_{DD}$  pin of the chip. As per standard design practice, be sure to include all of these capacitors and ensure that the smaller capacitors are close to each  $AV_{DD}$  pin with trace lengths as short as possible. Connect the ground terminal of each of these capacitors directly to the underlying ground plane.

Finally, note that the analog and digital ground pins on the ADuC7124/ADuC7126 must be referenced to the same system ground reference point at all times.

### $IOV_{DD}$ Supply Sensitivity

The  $IOV_{DD}$  supply is sensitive to high frequency noise because it is the supply source for the internal oscillator and PLL circuits. When the internal PLL loses lock, the clock source is removed by a gating circuit from the CPU, and the ARM7TDMI core stops executing code until the PLL regains lock. This feature ensures that no flash interface timings or ARM7TDMI timings are violated.

Typically, frequency noise greater than 50 kHz and 50 mV p-p on top of the supply causes the core to stop working.

If decoupling values recommended in the Power Supplies section do not sufficiently dampen all noise sources below 50 mV on  $IOV_{DD}$ , a filter such as the one shown in Figure 64 is recommended.

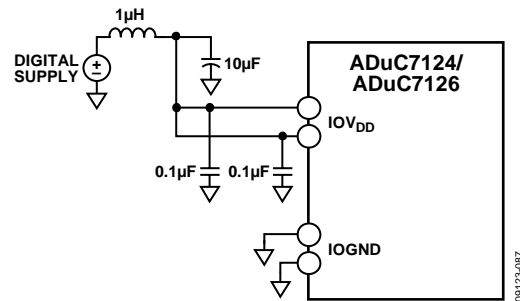

Figure 64. Recommended  $IOV_{DD}$  Supply Filter

### Linear Voltage Regulator

The ADuC7124/ADuC7126 require a single 3.3 V supply, but the core logic requires a 2.6 V supply. An on-chip linear regulator generates the 2.6 V from  $IOV_{DD}$  for the core logic. The  $LV_{DD}$  pin is the 2.6 V supply for the core logic. An external compensation capacitor of 0.47 µF must be connected between  $LV_{DD}$  and  $DGND$  (as close as possible to these pins) to act as a tank of charge as shown in Figure 65.

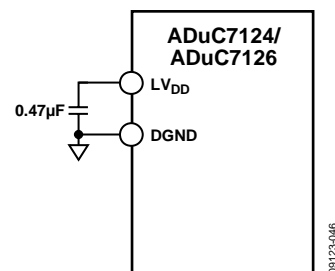

Figure 65. Voltage Regulator Connections

The  $LV_{DD}$  pin should not be used for any other chip. It is also recommended to use excellent power supply decoupling on  $IOV_{DD}$  to help improve line regulation performance of the on-chip voltage regulator.

**GROUNDING AND BOARD LAYOUT RECOMMENDATIONS**

As with all high resolution data converters, special attention must be paid to grounding and PC board layout of the ADuC7124/ADuC7126-based designs to achieve optimum performance from the ADCs and DAC.

Although the part has separate pins for analog and digital ground (AGND and IOGND), the user must not tie these to two separate ground planes unless the two ground planes are connected very close to the part. This is illustrated in the simplified example shown in Figure 66a. In systems where digital and analog ground planes are connected together somewhere else (at the power supply of the system, for example), the planes cannot be reconnected near the part because a ground loop results. In these cases, tie all the ADuC7124/ADuC7126 AGND and IOGND pins to the analog ground plane, as illustrated in Figure 66b. In systems with only one ground plane, ensure that the digital and analog components are physically separated onto separate halves of the board so that digital return currents do not flow near analog circuitry (and vice versa).

The ADuC7124/ADuC7126 can then be placed between the digital and analog sections, as illustrated in Figure 66c.

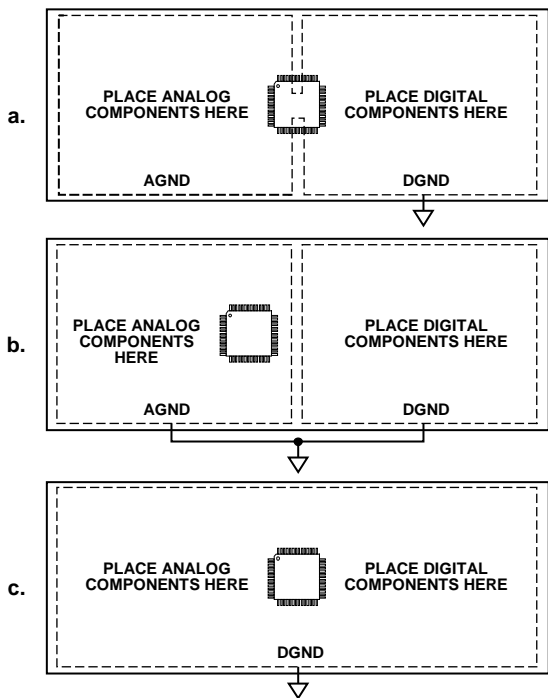

Figure 66. System Grounding Schemes

In all of these scenarios, and in more complicated real-life applications, the users should pay particular attention to the flow of current from the supplies and back to ground. Make sure the return paths for all currents are as close as possible to the paths the currents took to reach their destinations.

For example, do not power components on the analog side (as seen in Figure 66b) with IOV<sub>DD</sub> because that forces return currents from IOV<sub>DD</sub> to flow through AGND. Avoid digital currents flowing under analog circuitry, which can occur if a noisy digital chip is placed on the left half of the board (shown in Figure 66c). If possible, avoid large discontinuities in the ground plane(s), such as those formed by a long trace on the same layer, because they force return signals to travel a longer path. In addition, make all connections to the ground plane directly, with little or no trace separating the pin from its via to ground.

When connecting fast logic signals (rise/fall time < 5 ns) to any of the ADuC7124/ADuC7126 digital inputs, add a series resistor to each relevant line to keep rise and fall times longer than 5 ns at the input pins of the part. A value of 100 Ω or 200 Ω is usually sufficient to prevent high speed signals from coupling capacitively into the part and affecting the accuracy of ADC conversions.

**CLOCK OSCILLATOR**

The clock source for the ADuC7124/ADuC7126 can be generated by the internal PLL or by an external clock input. To use the internal PLL, connect a 32.768 kHz parallel resonant crystal between XCLKI and XCLKO, and connect a capacitor from each pin to ground as shown in Figure 67. The crystal allows the PLL to lock correctly to give a frequency of 41.78 MHz. If no external crystal is present, the internal oscillator is used to give a typical frequency of 32.768 kHz ± 3%.

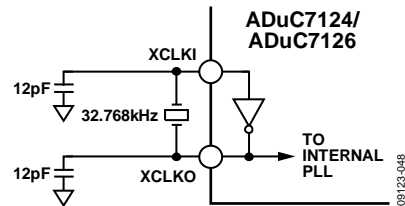

Figure 67. External Parallel Resonant Crystal Connections

To use an external source clock input instead of the PLL (see Figure 68), Bit 1 and Bit 0 of PLLCON must be modified. The external clock uses P0.7 and XCLK.

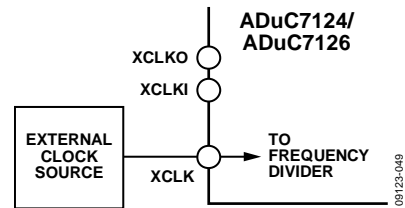

Figure 68. Connecting an External Clock Source

Using an external clock source, the ADuC7124/ADuC7126 specified operational clock speed range is 50 kHz to 41.78 MHz ± 1%, which ensures correct operation of the analog peripherals and Flash/EE.

### POWER-ON RESET OPERATION

An internal power-on reset (POR) is implemented on the [ADuC7124/ADuC7126](#). For  $LV_{DD}$  below 2.40 V typical, the internal POR holds the part in reset. As  $LV_{DD}$  rises above 2.41 V, an internal timer times out for typically 128 ms before the part is released from reset. The user must ensure that the power supply,  $IOV_{DD}$ , reaches a stable 2.7 V minimum level by this time. Likewise, on power-down, the internal POR holds the part in reset until  $LV_{DD}$  drops below 2.40 V. Figure 69 illustrates the operation of the internal POR in detail.

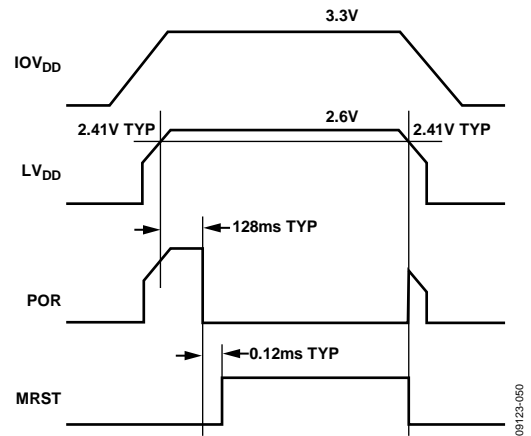
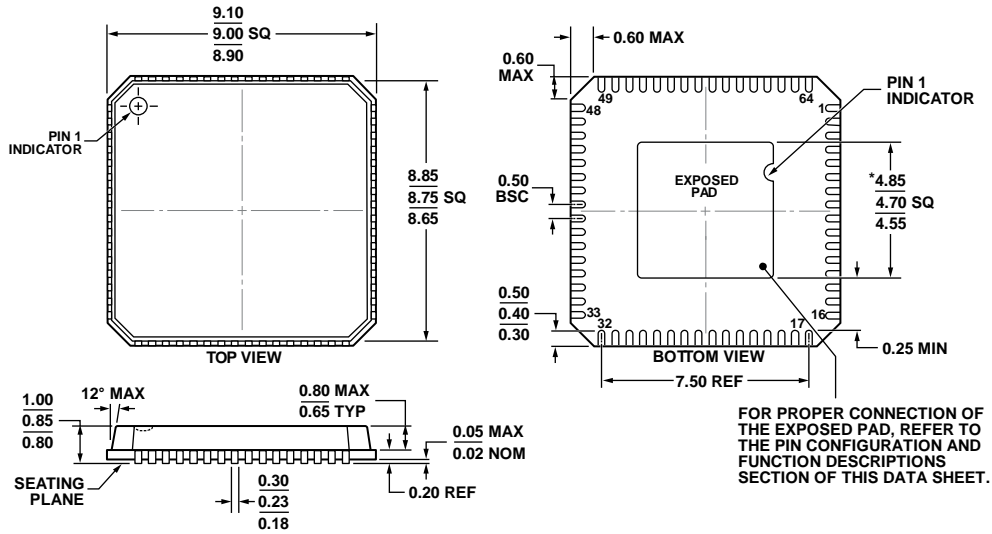

Figure 69. Internal Power-On Reset Operation

09123-050

OUTLINE DIMENSIONS



\*COMPLIANT TO JEDEC STANDARDS MO-220-VMM-4 EXCEPT FOR EXPOSED PAD DIMENSION

Figure 70. 64-Lead Frame Chip Scale Package [LFCS\_VQ]  
9 mm x 9 mm Body, Very Thin Quad (CP-64-1)  
Dimensions shown in millimeters

06-13-2012-A

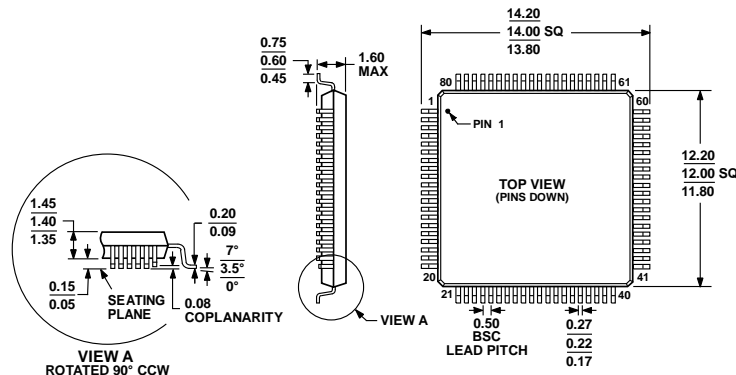

COMPLIANT TO JEDEC STANDARDS MS-026-BDD  
Figure 71. 80-Lead Low Profile Quad Flat Package [LQFP] (ST-80-1)  
Dimensions shown in millimeters

051706-A

## ORDERING GUIDE

Model <sup>1</sup>	ADC Channels	DAC Channels	Flash/RAM	GPIO	Downloader	Temperature Range	Package Description	Package Option	Ordering Quantity
ADuC7124BCPZ126	10	2	126 kB/32 kB	30	UART	−40°C to +125°C	64-Lead LFCSP_VQ	CP-64-1	260
ADuC7124BCPZ126-RL	10	2	126 kB/32 kB	30	UART	−40°C to +125°C	64-Lead LFCSP_VQ	CP-64-1	2500
ADuC7126BSTZ126	12	4	126 kB/32 kB	40	UART	−40°C to +125°C	80-Lead LQFP	ST-80-1	119
ADuC7126BSTZ126-RL	12	4	126 kB/32 kB	40	UART	−40°C to +125°C	80-Lead LQFP	ST-80-1	1000
ADuC7126BSTZ126I	12	4	126 kB/32 kB	40	I <sup>2</sup> C	−40°C to +125°C	80-Lead LQFP	ST-80-1	119
ADuC7126BSTZ126IRL	12	4	126 kB/32 kB	40	I <sup>2</sup> C	−40°C to +125°C	80-Lead LQFP	ST-80-1	1000
EVAL-ADuC7124QSPZ							<a href="#">ADuC7124</a> QuickStart Development System		
EVAL-ADuC7126QSPZ							<a href="#">ADuC7126</a> QuickStart Development System		

<sup>1</sup> Z = RoHS Compliant Part.

**NOTES**

**NOTES**

**NOTES**

I<sup>2</sup>C refers to a communications protocol originally developed by Philips Semiconductors (now NXP Semiconductors).

## Looking for pricing, stock, or lifecycle information?

Click below to explore more details on WIN SOURCE:

 [View ADUC7124BCPZ126 on WIN SOURCE](#)

 [Analog Devices Inc. Information](#)

## Optimize Your Supply Chain with WIN SOURCE Solutions

-  Global Sourcing Solution
-  Obsolete Management
-  Cost Control Management
-  Shortage Management
-  Alternative Solution
-  Excess Inventory Management