



THE DATASHEET OF AD7896AR-REEL



FEATURES

100 kHz Throughput Rate
Fast 12-Bit Sampling ADC with 8 μ s Conversion Time
8-Lead PDIP and SOIC
Single 2.7 V to 5.5 V Supply Operation
High Speed, Easy-to-Use Serial Interface
On-Chip Track-and-Hold Amplifier
Analog Input Range Is 0 V to Supply
High Input Impedance
Low Power: 9 mW Typ

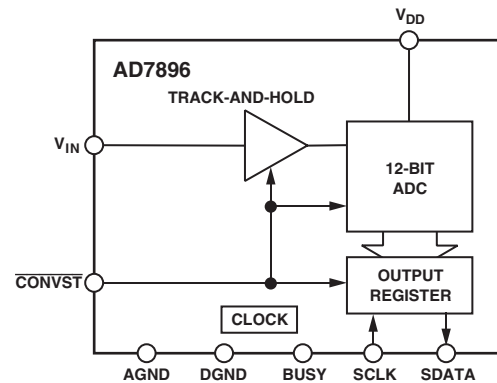
FUNCTIONAL BLOCK DIAGRAM

GENERAL DESCRIPTION

The AD7896 is a fast, 12-bit ADC that operates from a single 2.7 V to 5.5 V supply and is housed in small 8-lead PDIP and 8-lead SOIC packages. The part contains an 8 μ s successive approximation ADC, an on-chip track-and-hold amplifier, an on-chip clock, and a high speed serial interface.

Output data from the AD7896 is provided via a high speed, serial interface port. This 2-wire serial interface has a serial clock input and a serial data output with the external serial clock accessing the serial data from the part.

In addition to the traditional dc accuracy specifications, such as linearity, full-scale, and offset errors, the AD7896 is also specified for dynamic performance parameters, including harmonic distortion and signal-to-noise ratio.

The part accepts an analog input range of 0 V to V_{DD} and operates from a single 2.7 V to 5.5 V supply, consuming only 9 mW typical. The V_{DD} input is also used as the reference for the part so that no external reference is required.

The AD7896 features a high sampling rate mode and, for low power applications, a proprietary automatic power-down mode where the part automatically goes into power-down once conversion is complete and “wakes up” before the next conversion cycle.

The part is available in a small, 8-lead, 0.3” wide, plastic or hermetic dual-in-line package (PDIP) and in an 8-lead, small outline IC (SOIC).

PRODUCT HIGHLIGHTS

- 1. Complete, 12-bit ADC in an 8-Lead Package.**
 The AD7896 contains an 8 μ s ADC, a track-and-hold amplifier, control logic, and a high speed serial interface, all in an 8-lead PDIP. The V_{DD} input is used as the reference for the part, so no external reference is needed. This offers considerable space saving over alternative solutions.
- 2. Low Power, Single-Supply Operation.**
 The AD7896 operates from a single 2.7 V to 5.5 V supply and consumes only 9 mW typical. The automatic power-down mode, where the part goes into power down once conversion is complete and “wakes up” before the next conversion cycle, makes the AD7896 ideal for battery-powered or portable applications.
- 3. High Speed Serial Interface.**
 The part provides high speed serial data and serial clock lines allowing for an easy, 2-wire serial interface arrangement.

Rev. D

Information furnished by Analog Devices is believed to be accurate and reliable. However, no responsibility is assumed by Analog Devices for its use, nor for any infringements of patents or other rights of third parties that may result from its use. No license is granted by implication or otherwise under any patent or patent rights of Analog Devices. Trademarks and registered trademarks are the property of their respective companies.

AD7896—SPECIFICATIONS

($V_{DD} = 2.7\text{ V to }5.5\text{ V}$, $AGND = DGND = 0\text{ V}$. All specifications T_{MIN} to T_{MAX} , unless otherwise noted.)

Parameter	A Version ¹	B Version	J Version	S Version	Unit	Test Conditions/ Comments
DYNAMIC PERFORMANCE ²						
Signal-to-(Noise + Distortion) Ratio ³ @ 25°C	70	70	70 typ	70	dB min	$f_{IN} = 10\text{ kHz Sine Wave}$, $f_{SAMPLE} = 100\text{ kHz}$
T_{MIN} to T_{MAX} Total Harmonic Distortion (THD) ³	-77	70 -77	-80 typ	-77	dB min dB max	$f_{IN} = 10\text{ kHz Sine Wave}$, $f_{SAMPLE} = 100\text{ kHz}$
Peak Harmonic or Spurious Noise ³	-80	-80	-80 typ		dB max	$f_{IN} = 10\text{ kHz Sine Wave}$, $f_{SAMPLE} = 100\text{ kHz}$
Intermodulation Distortion (IMD) ³						$f_a = 9\text{ kHz}$, $f_b = 9.5\text{ kHz}$, $f_{SAMPLE} = 100\text{ kHz}$
Second Order Terms	-77	-77	-80 typ	-77	dB max	
Third Order Terms	-80	-80	-80 typ	-80	dB max	
DC ACCURACY						
Resolution	12	12	12	12	Bits	
Minimum Resolution for Which No Missing Codes Are Guaranteed	12	12	12	12	Bits	
Relative Accuracy ³	±1	±1/2	±1	±1	LSB max	
Differential Nonlinearity ³	±1	±1	±1	±1	LSB max	
Positive Full-Scale Error ³	±3	±1.5	±3	±3	LSB max	
Unipolar Offset Error	±4	±4	±5	±4	LSB max	$V_{DD} = 5\text{ V} \pm 10\%$
	±4	±3	±5	±4	LSB max	$V_{DD} = 2.7\text{ V to }3.6\text{ V}$
ANALOG INPUT						
Input Voltage Range	0 to $+V_{DD}$	0 to $+V_{DD}$	0 to $+V_{DD}$	0 to $+V_{DD}$	V	
Input Current	±2	±2	±2	±5	µA max	
LOGIC INPUTS						
Input High Voltage, V_{INH}	2.0	2.0	2.0	2.0	V min	$V_{DD} = 2.7\text{ V to }3.6\text{ V}$
	2.4	2.4	2.4	2.4		$V_{DD} = 5\text{ V} \pm 10\%$
Input Low Voltage, V_{INL}	0.8	0.8	0.8	0.8	V max	
Input Current, I_{IN}	±10	±10	±10	±10	µA max	$V_{IN} = 0\text{ V to }V_{DD}$
Input Capacitance, C_{IN} ⁴	10	10	10	10	pF max	
LOGIC OUTPUTS						
Output High Voltage, V_{OH}	2.4	2.4	2.4	2.4	V min	$I_{SOURCE} = 400\text{ µA}$
Output Low Voltage, V_{OL}	0.4	0.4	0.4	0.4	V max	$I_{SINK} = 1.6\text{ mA}$
Output Coding	Straight (Natural) Binary					
CONVERSION RATE						
Conversion Time						
Mode 1 Operation	8	8	8	8.5	µs max	
Mode 2 Operation ⁵	14	14	14	14.5	µs max	
Track-and-Hold Acquisition Time ³	1.5	1.5	1.5	1.5	µs max	

Parameter	A Version ¹	B Version	J Version	S Version	Unit	Test Conditions/ Comments
POWER REQUIREMENTS						
V _{DD}	2.7/5.5	2.7/5.5	2.7/5.5	2.7/5.5	V min/max	
I _{DD}	4	4	4	4	mA max	Digital Input @ DGND, V _{DD} = 2.7 V to 3.6 V
	5	5	5	5	mA max	Digital Inputs @ DGND, V _{DD} = 5 V ± 10%
Power Dissipation	10.8	10.8	10.8	10.8	mW max	V _{DD} = 2.7 V, Typically 9 mW
Power-Down Mode						Digital Inputs @ DGND
I _{DD} @ 25°C	5	5	5 typ	5	μA max	V _{DD} = 2.7 V to 3.6 V
T _{MIN} to T _{MAX}	15	15	75	75	μA max	V _{DD} = 2.7 V to 3.6 V
I _{DD} @ 25°C	50	50	50	50	μA max	V _{DD} = 5 V ± 10%
T _{MIN} to T _{MAX}	150	150	500	500	μA max	V _{DD} = 5 V ± 10%
Power Dissipation @ 25°C	13.5	13.5	13.5	13.5	μW max	V _{DD} = 2.7 V

NOTES

¹Temperature ranges are as follows: A, B Versions: -40°C to +85°C; J Version: 0°C to +70°C; S Version: -55°C to +125°C.

²Applies to Mode 1 operation. See the section on Operating Modes.

³See Terminology.

⁴Sample tested @ 25°C to ensure compliance.

⁵This 14 μs includes the wake-up time from standby. This wake-up time is timed from the rising edge of $\overline{\text{CONVST}}$, whereas conversion is timed from the falling edge of $\overline{\text{CONVST}}$, for narrow $\overline{\text{CONVST}}$ pulsewidth the conversion time is effectively the wake-up time plus conversion time, hence 14 μs. This can be seen from Figure 3. Note that if the $\overline{\text{CONVST}}$ pulsewidth is greater than 6 μs, the effective conversion time will increase beyond 14 μs.

Specifications subject to change without notice.

TIMING CHARACTERISTICS¹ (V_{DD} = 2.7 V to 5.5 V, AGND = DGND = 0 V)

Parameter	A, B Versions	J Version	S Version	Unit	Test Conditions/Comments
t ₁	40	40	40	ns min	$\overline{\text{CONVST}}$ Pulsewidth
t ₂	40 ²	40 ²	45 ²	ns min	SCLK High Pulsewidth
t ₃	40 ²	40 ²	45 ²	ns min	SCLK Low Pulsewidth
t ₄					Data Access Time after Falling Edge of SCLK
	60 ³	60 ³	70 ³	ns max	V _{DD} = 5 V ± 10%
	100 ³	100 ³	110 ³	ns max	V _{DD} = 2.7 V to 3.6 V
t ₅	10	10	10	ns min	Data Hold Time after Falling Edge of SCLK
t ₆	50 ⁴	50 ⁴	50 ⁴	ns max	Bus Relinquish Time after Falling Edge of SCLK

NOTES

¹Sample tested at 25°C to ensure compliance. All input signals are measured with tr = tf = 1 ns (10% to 90% of V_{DD}) and timed from a voltage level of 1.4 V.

²The SCLK maximum frequency is 10 MHz. Care must be taken when interfacing to account for the data access time, t₄, and the setup time required for the user's processor. These two times will determine the maximum SCLK frequency that the user's system can operate with. See Serial Interface section for more information.

³Measured with the load circuit of Figure 1 and defined as the time required for an output to cross 0.8 V or 2 V.

⁴Derived from the measured time taken by the data outputs to change 0.5 V when loaded with the circuit of Figure 1. The measured number is then extrapolated back to remove the effects of charging or discharging the 50 pF capacitor. This means that the time, t₆, quoted in the timing characteristics is the true bus relinquish time of the part and as such is independent of external bus loading capacitances.

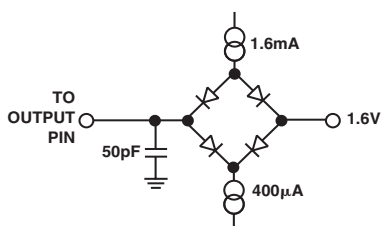

Figure 1. Load Circuit for Access Time and Bus Relinquish Time

AD7896

ABSOLUTE MAXIMUM RATINGS*

($T_A = 25^\circ\text{C}$, unless otherwise noted.)

V_{DD} to AGND -0.3 V to +7 V
V_{DD} to DGND -0.3 V to +7 V
Analog Input Voltage to AGND -0.3 V to $V_{DD} + 0.3$ V
Digital Input Voltage to DGND -0.3 V to $V_{DD} + 0.3$ V
Digital Output Voltage to DGND -0.3 V to $V_{DD} + 0.3$ V
Operating Temperature Range	
Commercial (J Version) 0°C to $+70^\circ\text{C}$
Industrial (A, B Versions) -40°C to $+85^\circ\text{C}$
Extended (S Version) -55°C to $+125^\circ\text{C}$
Storage Temperature Range -65°C to $+150^\circ\text{C}$
Junction Temperature 150°C

PDIP Package, Power Dissipation 450 mW
θ_{JA} Thermal Impedance $125^\circ\text{C}/\text{W}$
θ_{JC} Thermal Impedance $50^\circ\text{C}/\text{W}$
Lead Temperature (Soldering, 10 sec) 260°C
SOIC Package, Power Dissipation 450 mW
θ_{JA} Thermal Impedance $160^\circ\text{C}/\text{W}$
θ_{JC} Thermal Impedance $75^\circ\text{C}/\text{W}$
Lead Temperature, Soldering	
Vapor Phase (60 sec) 215°C
Infrared (15 sec) 220°C
ESD >4000 V

*Stresses above those listed under Absolute Maximum Ratings may cause permanent damage to the device. This is a stress rating only; functional operation of the device at these or any other conditions above those listed in the operational sections of this specification is not implied. Exposure to absolute maximum rating conditions for extended periods may affect device reliability.

CAUTION

ESD (electrostatic discharge) sensitive device. Electrostatic charges as high as 4000 V readily accumulate on the human body and test equipment and can discharge without detection. Although the AD7896 features proprietary ESD protection circuitry, permanent damage may occur on devices subjected to high energy electrostatic discharges. Therefore, proper ESD precautions are recommended to avoid performance degradation or loss of functionality.



PIN CONFIGURATION

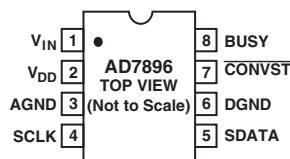

PIN FUNCTION DESCRIPTIONS

Pin No.	Mnemonic	Description
1	V _{IN}	Analog Input. The analog input range is 0 V to V _{DD} .
2	V _{DD}	Positive supply voltage, 2.7 V to 5.5 V.
3	AGND	Analog Ground. Ground reference for track-and-hold, comparator, and DAC.
4	SCLK	Serial Clock Input. An external serial clock is applied to this input to obtain serial data from the AD7896. A new serial data bit is clocked out on the falling edge of this serial clock. Data is guaranteed valid for 10 ns after this falling edge so data can be accepted on the falling edge when a fast serial clock is used. The serial clock input should be taken low at the end of the serial data transmission.
5	SDATA	Serial Data Output. Serial data from the AD7896 is provided at this output. The serial data is clocked out by the falling edge of SCLK, but the data can also be read on the falling edge of the SCLK. This is possible because data bit N is valid for a specified time after the falling edge of the SCLK (data hold time) and can be read before data bit N+1 becomes valid a specified time after the falling edge of SCLK (data access time) (see Figure 4). Sixteen bits of serial data are provided with four leading zeros followed by the 12 bits of conversion data. On the 16th falling edge of SCLK, the SDATA line is held for the data hold time and then disabled (three-stated). Output data coding is straight binary.
6	DGND	Digital Ground. Ground reference for digital circuitry.
7	$\overline{\text{CONVST}}$	Convert Start. Edge-triggered logic input. On the falling edge of this input, the track-and-hold goes into its hold mode and conversion is initiated. If $\overline{\text{CONVST}}$ is low at the end of conversion, the part goes into power-down mode. In this case, the rising edge of $\overline{\text{CONVST}}$ “wakes up” the part.
8	BUSY	The BUSY pin is used to indicate when the part is doing a conversion. The BUSY pin goes high on the falling edge of $\overline{\text{CONVST}}$ and returns low when the conversion is complete.

AD7896

TERMINOLOGY

Relative Accuracy

This is the maximum deviation from a straight line passing through the endpoints of the ADC transfer function. The endpoints of the transfer function are zero scale (which is $V_{IN} = AGND + 1/2 \text{ LSB}$), a point 1/2 LSB below the first code transition (00 . . . 000 to 00 . . . 001), and full scale (which is $V_{IN} = AGND + V_{DD} - 1/2 \text{ LSB}$), a point 1/2 LSB above the last code transition (11 . . . 110 to 11 . . . 111).

Differential Nonlinearity

This is the difference between the measured and the ideal 1 LSB change between any two adjacent codes in the ADC.

Unipolar Offset Error

This is the deviation of the first code transition (00 . . . 000 to 00 . . . 001) from the ideal V_{IN} voltage ($AGND + 1 \text{ LSB}$).

Positive Full-Scale Error

This is the deviation of the last code transition (11 . . . 110 to 11 . . . 111) from the ideal ($V_{IN} = AGND + V_{DD} - 1 \text{ LSB}$) after the offset error has been adjusted out.

Track-and-Hold Acquisition Time

Track-and-hold acquisition time is the time required for the output of the track-and-hold amplifier to reach its final value, within $\pm 1/2 \text{ LSB}$, after the end of conversion (the point at which the track-and-hold returns into track mode). It also applies to a situation where there is a step input change on the input voltage applied to the selected V_{IN} input of the AD7896. It means that the user must wait for the duration of the track-and-hold acquisition time after the end of conversion or after a step input change to V_{IN} before starting another conversion, to ensure the part operates to specification.

Signal-to-(Noise + Distortion) Ratio

This is the measured ratio of signal-to-(noise + distortion) at the output of the ADC. The signal is the rms amplitude of the fundamental. Noise is the sum of all nonfundamental signals up to half the sampling frequency ($f_s/2$), excluding dc. The ratio is dependent on the number of quantization levels in the digitization process; the more levels, the smaller the quantization noise. The theoretical signal-to-(noise + distortion) ratio for an ideal N-bit converter with a sine wave input is given by:

$$\text{Signal-to-(Noise + Distortion)} = (6.02N + 1.76) \text{ dB}$$

Thus, for a 12-bit converter, this is 74 dB.

Total Harmonic Distortion

Total harmonic distortion (THD) is the ratio of the rms sum of harmonics to the fundamental. For the AD7896, it is defined as:

$$\text{THD (dB)} = 20 \log \frac{\sqrt{V_2^2 + V_3^2 + V_4^2 + V_5^2 + V_6^2}}{V_1}$$

where V_1 is the rms amplitude of the fundamental and $V_2, V_3, V_4, V_5,$ and V_6 are the rms amplitudes of the second through the sixth harmonics.

Peak Harmonic or Spurious Noise

Peak harmonic or spurious noise is defined as the ratio of the rms value of the next largest component in the ADC output spectrum (up to $f_s/2$ and excluding dc) to the rms value of the fundamental. Normally, the value of this specification is determined by the largest harmonic in the spectrum, but for parts where the harmonics are buried in the noise floor, it will be a noise peak.

Intermodulation Distortion

With inputs consisting of sine waves at two frequencies, f_a and f_b , any active device with nonlinearities will create distortion products at sum and difference frequencies of $m f_a \pm n f_b$ where $m, n = 0, 1, 2, 3,$ etc. Intermodulation distortion terms are those for which neither m nor n are equal to zero. For example, the second order terms include $(f_a + f_b)$ and $(f_a - f_b)$, while the third order terms include $(2f_a + f_b), (2f_a - f_b), (f_a + 2f_b),$ and $(f_a - 2f_b)$.

The AD7896 is tested using the CCIF standard where two input frequencies near the top end of the input bandwidth are used. In this case, the second order terms are usually distanced in frequency from the original sine waves while the third order terms are usually at a frequency close to the input frequencies. As a result, the second and third order terms are specified separately. The calculation of the intermodulation distortion is as per the THD specification where it is the ratio of the rms sum of the individual distortion products to the rms amplitude of the fundamental expressed in dB.

CONVERTER DETAILS

The AD7896 is a fast, 12-bit ADC that operates from a single 2.7 V to 5.5 V supply. It provides the user with a track-and-hold, ADC, and serial interface logic functions on a single chip. The ADC section of the AD7896 consists of a conventional successive approximation converter based on an R-2R ladder structure. The internal reference for the AD7896 is derived from V_{DD} , which allows the part to accept an analog input range of 0 V to V_{DD} . The AD7896 has two operating modes: the high sampling mode and the auto sleep mode where the part automatically goes into sleep after the end of conversion. These modes are discussed in more detail in the Timing and Control section.

A major advantage of the AD7896 is that it provides all of the preceding functions in an 8-lead package, PDIP or SOIC. This offers the user considerable space saving advantages over alternative solutions. The AD7896 consumes only 9 mW typical, making it ideal for battery-powered applications.

Conversion is initiated on the AD7896 by pulsing the $\overline{\text{CONVST}}$ input. On the falling edge of $\overline{\text{CONVST}}$, the on-chip track-and-hold goes from track to hold mode and the conversion sequence is started. The conversion clock for the part is generated internally using a laser-trimmed clock oscillator circuit. Conversion time for the AD7896 is 8 μs in the high sampling mode (14 μs for the auto sleep mode), and the track-and-hold acquisition time is 1.5 μs . To obtain optimum performance from the part, the read operation should not occur during the conversion or during 400 ns prior to the next conversion. This allows the part to operate at throughput rates up to 100 kHz and achieves data sheet specifications (see the Timing and Control section).

CIRCUIT DESCRIPTION

Analog Input Section

The analog input range for the AD7896 is 0 V to V_{DD} . The V_{IN} pin drives the input to the track-and-hold amplifier directly. This allows for a maximum output impedance of the circuit driving the analog input of 1 k Ω . This ensures that the part will be settled to 12-bit accuracy in the 1.5 μs acquisition time. This input is benign with dynamic charging currents. The designed code transitions occur on successive integer LSB values (i.e., 1 LSB, 2 LSB, 3 LSB, . . . , FS – 1 LSB). Output coding is straight (natural) binary with 1 LSB = $\text{FS}/4096 = 3.3 \text{ V}/4096 = 0.81 \text{ mV}$. The ideal input/output transfer function is shown in Table I.

Table I. Ideal Input/Output Code Table for the AD7896

Analog Input ¹	Code Transition
+FSR – 1 LSB ² (3.299194)	111 . . . 110 to 111 . . . 111
+FSR – 2 LSB (3.298389)	111 . . . 101 to 111 . . . 110
+FSR/2 – 3 LSB (3.297583)	111 . . . 100 to 111 . . . 101
AGND + 3 LSB (0.002417)	000 . . . 010 to 000 . . . 011
AGND + 2 LSB (0.001611)	000 . . . 001 to 000 . . . 010
AGND + 1 LSB (0.000806)	000 . . . 000 to 000 . . . 001

NOTES

¹FSR is full-scale range and is 3.3 V with $V_{DD} = +3.3 \text{ V}$.

²1 LSB = $\text{FSR}/4096 = 0.81 \text{ mV}$ with $V_{DD} = +3.3 \text{ V}$.

Track-and-Hold Section

The track-and-hold amplifier on the analog input of the AD7896 allows the ADC to accurately convert an input sine wave of full-scale amplitude to 12-bit accuracy. The input bandwidth of the

track-and-hold is greater than the Nyquist rate of the ADC even when the ADC is operated at its maximum throughput rate of 100 kHz (i.e., the track-and-hold can handle input frequencies in excess of 50 kHz).

The track-and-hold amplifier acquires an input signal to 12-bit accuracy in less than 1.5 μs . The operation of the track-and-hold is essentially transparent to the user. With the high sampling operating mode, the track-and-hold amplifier goes from its tracking mode to its hold mode at the start of conversion (i.e., the rising edge of $\overline{\text{CONVST}}$). The aperture time for the track-and-hold (i.e., the delay time between the external $\overline{\text{CONVST}}$ signal and the track-and-hold actually going into hold) is typically 15 ns. At the end of conversion (on the falling edge of $\overline{\text{CONVST}}$), the part returns to its tracking mode. The acquisition time of the track-and-hold amplifier begins at this point. For the auto shutdown mode, the rising edge of $\overline{\text{CONVST}}$ wakes up the part and the track-and-hold amplifier goes from its tracking mode to its hold mode 6 μs after the rising edge of $\overline{\text{CONVST}}$ (provided that the $\overline{\text{CONVST}}$ high time is less than 6 μs). Once again the part returns to its tracking mode at the end of conversion when the $\overline{\text{CONVST}}$ signal goes low.

Timing and Control

Figure 2 shows the timing and control sequence required to obtain optimum performance from the AD7896. In the sequence shown, conversion is initiated on the falling edge of $\overline{\text{CONVST}}$ and new data from this conversion is available in the output register of the AD7896 8 μs later. Once the read operation has taken place, another 400 ns should be allowed before the next falling edge of $\overline{\text{CONVST}}$ to optimize the settling of the track-and-hold amplifier before the next conversion is initiated. With the serial clock frequency at its maximum of 10 MHz (5 V operation), the achievable throughput time for the part is 8 μs (conversion time) plus 1.6 μs (read time) plus 0.4 μs (acquisition time). This results in a minimum throughput time of 10 μs (equivalent to a throughput rate of 100 kHz). A serial clock of less than 10 MHz can be used, but this will in turn mean that the throughput time will increase.

The read operation consists of 16 serial clock pulses to the output shift register of the AD7896. After 16 serial clock pulses, the shift register is reset and the $\overline{\text{SDATA}}$ line is three-stated. If there are more serial clock pulses after the 16th clock, the shift register will be moved on past its reset state. However, the shift register will be reset again on the falling edge of the $\overline{\text{CONVST}}$ signal to ensure that the part returns to a known state every conversion cycle. As a result, a read operation from the output register should not straddle across the falling edge of $\overline{\text{CONVST}}$ as the output shift register will be reset in the middle of the read operation and the data read back into the microprocessor will appear invalid.

The throughput rate of the part can be increased by reading data during conversion. If the data is read during conversion, a throughput time of 8 μs (conversion time) plus 1.5 μs (acquisition time) is achieved when a 10 MHz, (5 V operation) serial clock is being used. This minimum throughput time of 9.5 μs is achieved with a slight reduction in performance from the AD7896. The advantage of this arrangement is that when the serial clock is significantly lower than 10 MHz, the throughput time for this arrangement will be significantly less than the throughput time where the data is read after conversion. The signal-to-(noise + distortion) number is likely to degrade by less than 1 dB while the code flicker from the part will also increase (see the AD7896 Performance section).

AD7896

OPERATING MODES

Mode 1 Operation (High Sampling Performance)

The timing diagram in Figure 2 is for optimum performance in Operating Mode 1 where the falling edge of $\overline{\text{CONVST}}$ starts the conversion and puts the track-and-hold amplifier into its hold mode. This falling edge of $\overline{\text{CONVST}}$ also causes the BUSY signal to go high to indicate that a conversion is taking place. The BUSY signal goes low when the conversion is complete, which is $8\ \mu\text{s}$ max after the falling edge of $\overline{\text{CONVST}}$, and new data from this conversion is available in the output register of the AD7896. A read operation accesses this data. This read operation consists of 16 clock cycles, and the length of this read operation depends on the serial clock frequency. For the fastest throughput rate (with a serial clock of 10 MHz at 5 V operation), the read operation will take $1.6\ \mu\text{s}$. The read operation must be complete at least $400\ \text{ns}$ before the falling edge of the next $\overline{\text{CONVST}}$, which gives a total time of $10\ \mu\text{s}$ for the full throughput time (equivalent to 100 kHz). This mode of operation should be used for high sampling applications.

Mode 2 Operation (Auto Sleep after Conversion)

The timing diagram in Figure 3 is for optimum performance in Operating Mode 2 where the part automatically goes into sleep mode once BUSY goes low after conversion and “wakes up”

before the next conversion takes place. This is achieved by keeping $\overline{\text{CONVST}}$ low at the end of conversion, whereas it was high at the end of conversion for Mode 1 operation. The rising edge of $\overline{\text{CONVST}}$ “wakes up” the part. This wake-up time is $6\ \mu\text{s}$, at which point the track-and-hold amplifier goes into its hold mode. The conversion takes $8\ \mu\text{s}$ after this, provided the $\overline{\text{CONVST}}$ has gone low, giving a total of $14\ \mu\text{s}$ from the rising edge of $\overline{\text{CONVST}}$ to the conversion being complete, which is indicated by the BUSY going low. Note that since the wake-up time from the rising edge of $\overline{\text{CONVST}}$ is $6\ \mu\text{s}$, when the $\overline{\text{CONVST}}$ pulsewidth is greater than $6\ \mu\text{s}$, the conversion will take more than the $14\ \mu\text{s}$ shown in the diagram from the rising edge of $\overline{\text{CONVST}}$. This is because the track-and-hold amplifier goes into its hold mode on the falling edge of $\overline{\text{CONVST}}$ and then the conversion will not be complete for a further $8\ \mu\text{s}$. In this case, the BUSY will be the best indicator for when the conversion is complete. Even though the part is in sleep mode, data can still be read from the part. The read operation consists of 16 clock cycles as in Mode 1 operation. For the fastest serial clock of 10 MHz at 5 V operation, the read operation will take $1.6\ \mu\text{s}$, which must be complete at least $400\ \text{ns}$ before the falling edge of the next $\overline{\text{CONVST}}$ to allow the track-and-hold amplifier to have enough time to settle. This mode is very useful when the part is converting at a slow rate as the power consumption will be significantly reduced from that of Mode 1 operation.

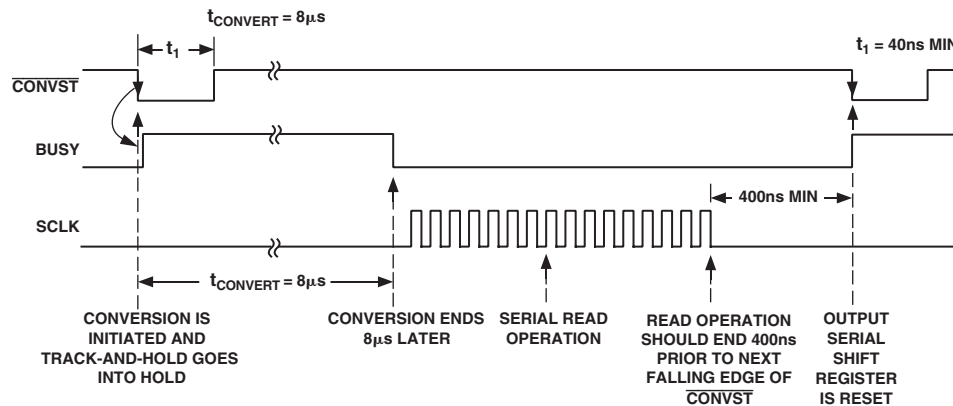

Figure 2. Mode 1 Timing Operation Diagram for High Sampling Performance

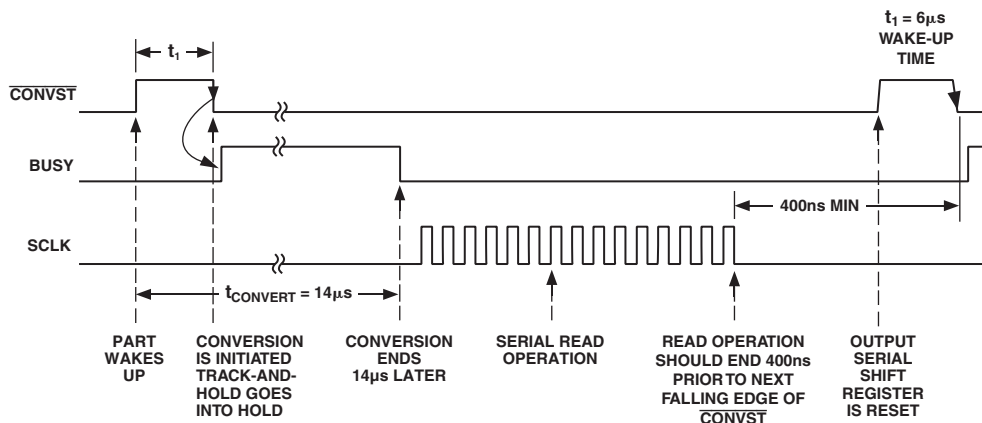

Figure 3. Mode 2 Timing Diagram Where Automatic Sleep Function Is Initiated

Serial Interface

The serial interface to the AD7896 consists of three wires: a serial clock input (SCLK), the serial data output (SDATA), and a conversion status output (BUSY). This allows for an easy-to-use interface to most microcontrollers, DSP processors, and shift registers.

Figure 4 shows the timing diagram for the read operation to the AD7896. The serial clock input (SCLK) provides the clock source for the serial interface. Serial data is clocked out from the SDATA line on the falling edge of this clock and is valid on both the rising and falling edges of SCLK. The advantage of having the data valid on both the rising and falling edges of the SCLK is to give the user greater flexibility in interfacing to the part and so that a wider range of microprocessor and microcontroller interfaces can be accommodated. This also explains the two timing figures t_4 and t_5 that are quoted on the diagram. The time t_4 specifies how long after the falling edge of the SCLK that the next data bit becomes valid, whereas the time t_5 specifies how long after the falling edge of the SCLK that the current data bit is valid for. The first leading zero is clocked out on the first rising edge of SCLK; note that the first zero may be valid on the first falling edge of SCLK even though the data access time is specified at 60 ns (5 V [A, B, J versions only]) for the other bits (and the SCLK high time will be 50 ns with a 10 MHz SCLK). The reason that the first bit will be clocked out faster than the other bits is due to the internal architecture of the part. Sixteen clock pulses must be provided to the part to access the full conversion result.

The AD7896 provides four leading zeros followed by the 12-bit conversion result starting with the MSB (DB11). The last data bit to be clocked out on the penultimate falling clock edge is the LSB (DB0). On the 16th falling edge of SCLK, the LSB (DB0) will be valid for a specified time to allow the bit to be read on the falling edge of SCLK, and then the SDATA line is disabled (three-stated). After this last bit has been clocked out, the SCLK input should remain low until the next serial data read operation. If there are extra clock pulses after the 16th clock, the AD7896 will start over again with outputting data from its output register, and the data bus will no longer be three-stated even when the clock stops. Provided the serial clock has stopped before the next falling edge of $\overline{\text{CONVST}}$, the AD7896 will continue to operate correctly with the output shift register being reset on the falling edge of $\overline{\text{CONVST}}$. However, the SCLK line

must be low when $\overline{\text{CONVST}}$ goes low in order to reset the output shift register correctly.

The serial clock input does not need to be continuous during the serial read operation. The 16 bits of data (four leading zeros and 12-bit conversion result) can be read from the AD7896 in a number of bytes. However, the SCLK input must remain low between the two bytes.

The maximum SCLK frequency is 10 MHz for 5 V operation (giving a throughput of 100 kHz) and at 2.7 V the maximum SCLK frequency is less than 10 MHz to allow for the longer data access time, t_4 (60 ns @ 5 V, 100 ns @ 2.7 V (A, B, J versions), 70 ns @ 5 V, 110 ns @ 2.7 V (S version)). Note that at 3.0 V operation (A, B, J versions), an SCLK of 10 MHz (throughput rate of 100 kHz) may be acceptable if the required processor setup time is 0 ns (this may be possible with an ASIC or FPGA). The data must be read in the next 10 ns, which is specified as the data hold time, t_5 , after the SCLK edge.

The AD7896 counts the serial clock edges to know which bit from the output register should be placed on the SDATA output. To ensure that the part does not lose synchronization, the serial clock counter is reset on the falling edge of the $\overline{\text{CONVST}}$ input provided the SCLK line is low. The user should ensure that a falling edge on the $\overline{\text{CONVST}}$ input does not occur while a serial data read operation is in progress.

MICROPROCESSOR/MICROCONTROLLER INTERFACE

The AD7896 provides a 3-wire serial interface that can be used for connection to the serial ports of DSP processors and microcontrollers. Figures 5 through 8 show the AD7896 interfaced to a number of different microcontrollers and DSP processors. The AD7896 accepts an external serial clock and as a result, in all interfaces shown here, the processor/controller is configured as the master, providing the serial clock, with the AD7896 configured as the slave in the system.

AD7896-8051 Interface

Figure 5 shows an interface between the AD7896 and the 8X51/L51 microcontroller. The 8X51/L51 is configured for its Mode 0 serial interface mode. The diagram shows the simplest form of the interface where the AD7896 is the only part connected to the serial port of the 8X51/L51 and, therefore, no decoding of the serial read operations is required.

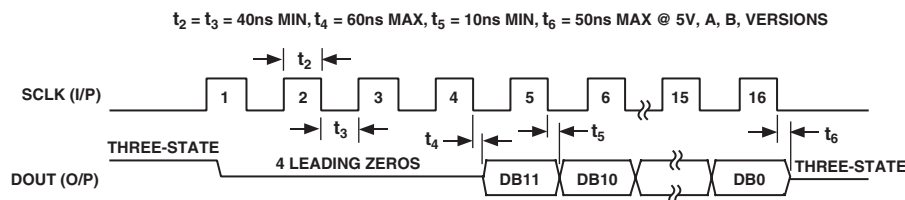

Figure 4. Data Read Operation

AD7896

To chip select the AD7896 in systems where more than one device is connected to the 8X51/L51 serial port, a port bit, configured as an output, from one of the 8X51/L51 parallel ports can be used to gate on or off the serial clock to the AD7896. A simple AND function on this port bit and the serial clock from the 8X51/L51 will provide this function. The port bit should be high to select the AD7896 and low when it is not selected.

The end of conversion is monitored by using the BUSY signal, which is shown in the interface diagram of Figure 5, with the BUSY line from the AD7896 connected to the Port P1.2 of the 8X51/L51 so the BUSY line can be polled by the 8X51/L51. The BUSY line can be connected to the INT1 line of the 8X51/L51 if an interrupt driven system is preferred. These two options are shown on the diagram.

Note also that the AD7896 outputs the MSB first during a read operation while the 8X51/L51 expects the LSB first. Therefore, the data that is read into the serial buffer needs to be rearranged before the correct data format from the AD7896 appears in the accumulator.

The serial clock rate from the 8X51/L51 is limited to significantly less than the allowable input serial clock frequency with which the AD7896 can operate. As a result, the time to read data from the part will actually be longer than the conversion time of the part. This means that the AD7896 cannot run at its maximum throughput rate when used with the 8X51/L51.

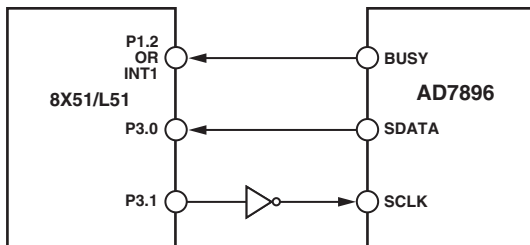

Figure 5. AD7896 to 8X51/L51 Interface

AD7896–68HC11/L11 Interface

An interface circuit between the AD7896 and the 68HC11/L11 microcontroller is shown in Figure 6. For the interface shown, the 68HC11/L11 SPI port is used and the 68HC11/L11 is configured in its single-chip mode. The 68HC11/L11 is configured in the master mode with its CPOL bit set to a Logic 0 and its CPHA bit set to a Logic 1. As with the previous interface, the diagram shows the simplest form of the interface, where the AD7896 is the only part connected to the serial port of the 68HC11/L11 and, therefore, no decoding of the serial read operations is required.

Once again, to chip select the AD7896 in systems where more than one device is connected to the 68HC11/L11 serial port, a port bit, configured as an output, from one of the 68HC11/L11 parallel ports can be used to gate on or off the serial clock to the AD7896. A simple AND function on this port bit and the serial clock from the 68HC11/L11 will provide this function. The port bit should be high to select the AD7896 and low when it is not selected.

The end of conversion is monitored by using the BUSY signal which is shown in the interface diagram of Figure 6. With the BUSY line from the AD7896 connected to the Port PC2 of the 68HC11/L11, the BUSY line can be polled by the 68HC11/L11.

The BUSY line can be connected to the $\overline{\text{IRQ}}$ line of the 68HC11/L11 if an interrupt driven system is preferred. These two options are shown in the diagram.

The serial clock rate from the 68HC11/L11 is limited to significantly less than the allowable input serial clock frequency with which the AD7896 can operate. As a result, the time to read data from the part will actually be longer than the conversion time of the part. This means that the AD7896 cannot run at its maximum throughput rate when used with the 68HC11/L11.

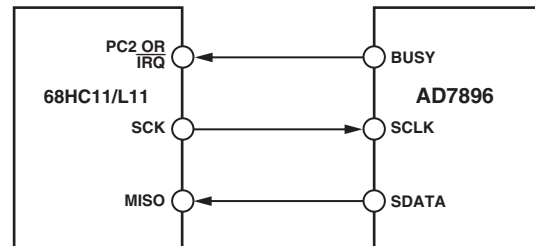

Figure 6. AD7896 to 68HC11/L11 Interface

AD7896–ADSP-2105 Interface

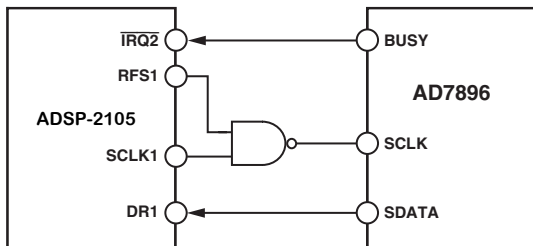

Figure 7. AD7896 to ADSP-2105 Interface

AD7896–DSP56002/L002 Interface

Figure 8 shows an interface circuit between the AD7896 and the DSP56002/L002 DSP processor. The DSP56002/L002 is configured for normal mode asynchronous operation with gated clock. It is also set up for a 16-bit word with SCK as gated clock output. In this mode, the DSP56002/L002 provides 16 serial clock pulses to the AD7896 in a serial read operation. The DSP56002/L002 assumes valid data on the first falling edge of SCK so the interface is simply 2-wire as shown in Figure 8.

The BUSY line from the AD7896 is connected to the MODA/IRQA input of the DSP56002/L002 so that an interrupt will be generated at the end of conversion. This ensures that the read operation will take place after conversion is finished.

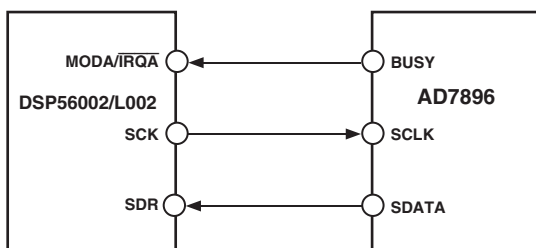

Figure 8. AD7896 to DSP56002/L002 Interface

AD7896 PERFORMANCE

Linearity

The linearity of the AD7896 is determined by the on-chip 12-bit DAC. This is a segmented DAC that is laser trimmed for 12-bit integral linearity and differential linearity. Typical relative accuracy numbers for the part are $\pm 1/4$ LSB, while the typical DNL errors are $\pm 1/2$ LSB.

Noise

In an ADC, noise exhibits itself as code uncertainty in dc applications and as the noise floor (in an FFT, for example) in ac applications. In a sampling ADC like the AD7896, all information about the analog input appears in the baseband from dc to $1/2$ the sampling frequency. The input bandwidth of the track-and-hold exceeds the Nyquist bandwidth and, therefore, an antialiasing filter should be used to remove unwanted signals above $f_s/2$ in the input signal in applications where such signals exist.

Figure 9 shows a histogram plot for 8192 conversions of a dc input using the AD7896 with a 3.3 V supply. The analog input was set at the center of a code transition. It can be seen that almost all the codes appear in the one output bin, indicating very good noise performance from the ADC. The rms noise performance for the AD7896 for the plot below was $111 \mu\text{V}$.

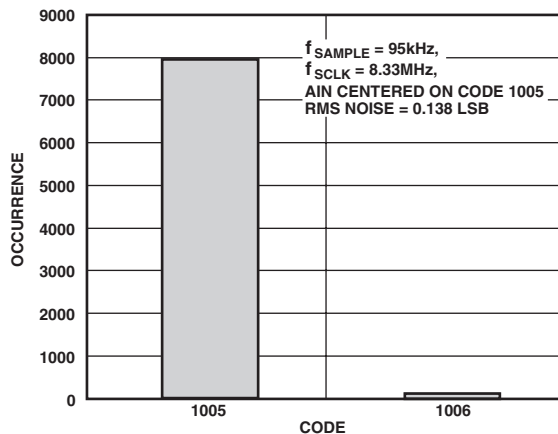

Figure 9. Histogram of 8192 Conversions of a DC Input

The same data is presented in Figure 10 as in Figure 9, except that in this case, the output data read for the device occurs during conversion. This has the effect of injecting noise onto the die while bit decisions are being made and this increases the noise generated by the AD7896. The histogram plot for 8192 conversions of the same dc input now shows a larger spread of codes with the rms noise for the AD7896 increasing to $279 \mu\text{V}$. This effect will vary depending on where the serial clock edges appear with respect to the bit trials of the conversion process. It is possible to achieve the same level of performance when reading during conversion as when reading after conversion, depending on the relationship of the serial clock edges to the bit trial points.

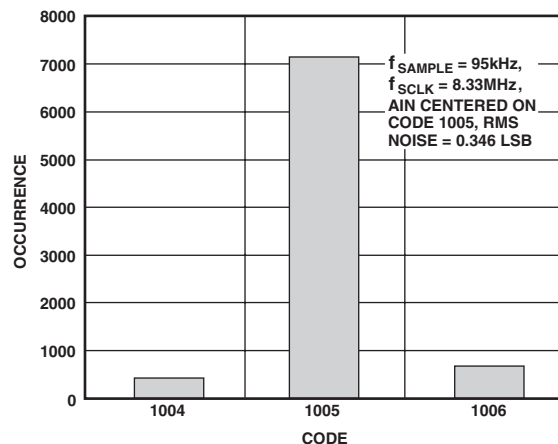

Figure 10. Histogram of 8192 Conversions with Read during Conversion

AD7896

Dynamic Performance (Mode 1 Only)

With a combined conversion and acquisition time of 9.5 μs , the AD7896 is ideal for wide bandwidth signal processing applications. These applications require information on the ADC's effect on the spectral content of the input signal. Signal-to-(noise + distortion), total harmonic distortion, peak harmonic or spurious noise, and intermodulation distortion are all specified. Figure 11 shows a typical FFT plot of a 10 kHz, 0 V to 3.3 V input after being digitized by the AD7896 operating at a 102.4 kHz sampling rate. The signal-to-(noise + distortion) ratio is 71.5 dB and the total harmonic distortion is -82.4 dB.

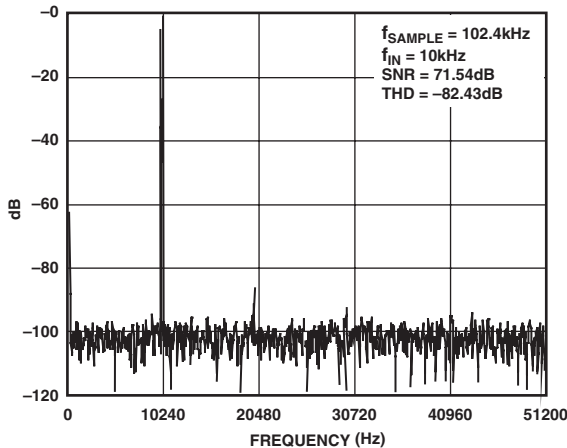

Figure 11. AD7896 FFT Plot

Effective Number of Bits

The formula for signal-to-(noise + distortion) ratio (see the Terminology section) is related to the resolution or number of bits in the converter. Rewriting the formula below gives a measure of performance expressed in effective number of bits (N)

$$N = (\text{SNR} - 1.76) / 6.02$$

where SNR is the signal-to-(noise + distortion) ratio.

The effective number of bits for a device can be calculated from its measured signal-to-(noise + distortion) ratio. Figure 12 shows a typical plot of effective number of bits versus frequency for the AD7896 from dc to $f_{\text{SAMPLING}}/2$. The sampling frequency is 102.4 kHz. The plot shows that the AD7896 converts an input sine wave of 51.2 kHz to an effective numbers of bits of 11.25, which equates to a signal-to-(noise + distortion) level of 69 dB.

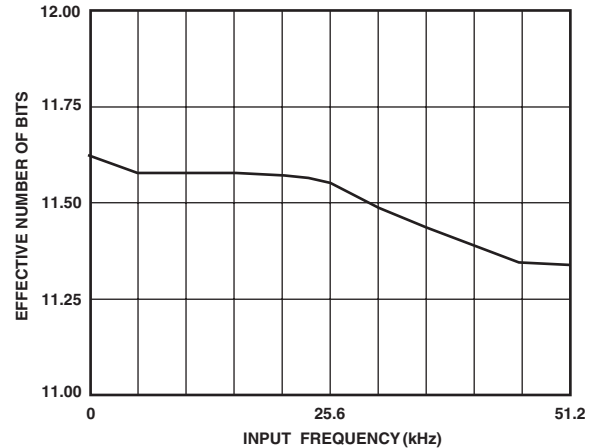

Figure 12. Effective Number of Bits vs. Frequency

Power Considerations

In the automatic power-down mode, the part can be operated at a sample rate that is considerably less than 100 kHz. In this case, the power consumption will be reduced and will depend on the sample rate. Figure 13 shows a graph of the power consumption versus sampling rates from 10 Hz to 1 kHz in the automatic power-down mode. The conditions are 2.7 V supply, 25°C, serial clock frequency of 8.33 MHz, and the data was read after conversion.

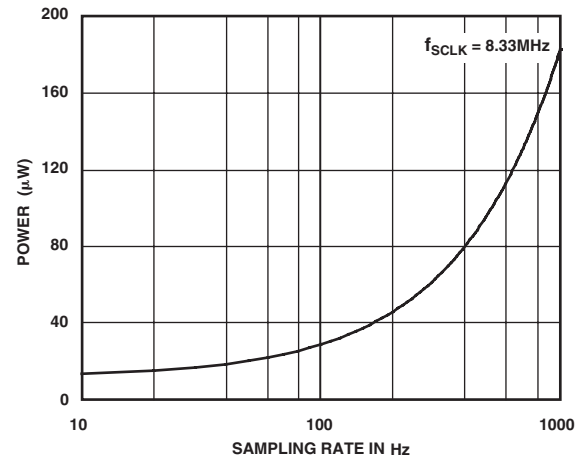
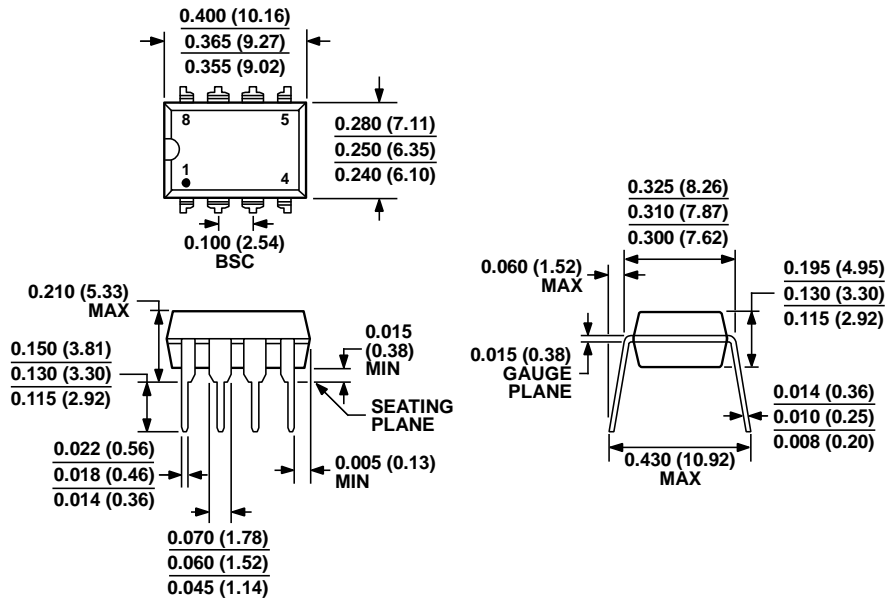

Figure 13. Power vs. Sample Rate in Auto Power-Down Mode

OUTLINE DIMENSIONS



COMPLIANT TO JEDEC STANDARDS MS-001

CONTROLLING DIMENSIONS ARE IN INCHES; MILLIMETER DIMENSIONS (IN PARENTHESES) ARE ROUNDED-OFF INCH EQUIVALENTS FOR REFERENCE ONLY AND ARE NOT APPROPRIATE FOR USE IN DESIGN. CORNER LEADS MAY BE CONFIGURED AS WHOLE OR HALF LEADS.

Figure 14. 8-Lead Plastic Dual In-Line Package [PDIP] Narrow Body (N-8)

Dimensions shown in inches and (millimeters)

070606-A

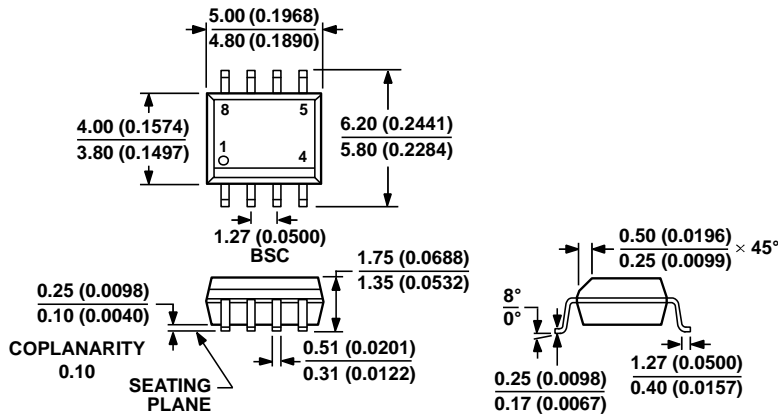

COMPLIANT TO JEDEC STANDARDS MS-012-AA

CONTROLLING DIMENSIONS ARE IN MILLIMETERS; INCH DIMENSIONS (IN PARENTHESES) ARE ROUNDED-OFF MILLIMETER EQUIVALENTS FOR REFERENCE ONLY AND ARE NOT APPROPRIATE FOR USE IN DESIGN.

Figure 15. 8-Lead Standard Small Outline Package [SOIC_N] Narrow Body (R-8)

Dimensions shown in millimeters and (inches)

012407-A

AD7896

ORDERING GUIDE

Model ¹	Linearity Error (LSB)	SNR (dB)	Temperature Range	Package Description	Package Option
AD7896AN	±1	70	−40°C to +85°C	8-Lead PDIP	N-8
AD7896ANZ	±1	70	−40°C to +85°C	8-Lead PDIP	N-8
AD7896AR	±1	70	−40°C to +85°C	8-Lead SOIC_N	R-8
AD7896AR-REEL	±1	70	−40°C to +85°C	8-Lead SOIC_N	R-8
AD7896ARZ	±1	70	−40°C to +85°C	8-Lead SOIC_N	R-8
AD7896ARZ-REEL	±1	70	−40°C to +85°C	8-Lead SOIC_N	R-8
AD7896ARZ-REEL7	±1	70	−40°C to +85°C	8-Lead SOIC_N	R-8
AD7896BR	±1/2	70	−40°C to +85°C	8-Lead SOIC_N	R-8
AD7896BR-REEL	±1/2	70	−40°C to +85°C	8-Lead SOIC_N	R-8
AD7896BRZ	±1/2	70	−40°C to +85°C	8-Lead SOIC_N	R-8
AD7896BRZ-REEL	±1/2	70	−40°C to +85°C	8-Lead SOIC_N	R-8
AD7896BRZ-REEL7	±1/2	70	−40°C to +85°C	8-Lead SOIC_N	R-8
AD7896JR	±1	70	0°C to +70°C	8-Lead SOIC_N	R-8
AD7896JRZ	±1	70	0°C to +70°C	8-Lead SOIC_N	R-8
AD7896JRZ-REEL	±1	70	0°C to +70°C	8-Lead SOIC_N	R-8

¹ Z = RoHS Compliant Part.

REVISION HISTORY

11/11—Rev. C to Rev. D

Changes to Total Harmonic Distortion (THD) Parameter and
to Intermodulation Distortion (IMD) Parameter.....2
Changes to AD7896–ADSP-2105 Interface Section.....10
Updated Outline Dimensions.....13
Changes to Ordering Guide.....14

7/03—Rev. B to Rev. C

Changes to Specifications.....2
Changes to Figure 1.....3
Changes to Ordering Guide.....4
Added ESD Caution Section.....4
Updated Outline Dimensions.....13

Looking for pricing, stock, or lifecycle information?

Click below to explore more details on WIN SOURCE:

 [View AD7896AR-REEL on WIN SOURCE](#)

 [Analog Devices Inc. Information](#)

Optimize Your Supply Chain with WIN SOURCE Solutions

-  Global Sourcing Solution
-  Obsolete Management
-  Cost Control Management
-  Shortage Management
-  Alternative Solution
-  Excess Inventory Management