

FEATURES

- **Controlled Baseline**
 - One Assembly/Test Site, One Fabrication Site
- **Extended Temperature Performance of –55°C to 125°C**
- **Enhanced Diminishing Manufacturing Sources (DMS) Support**
- **Enhanced Product-Change Notification**
- **Qualification Pedigree ⁽¹⁾**
- **Single-Supply Operation**
- **Rail-to-Rail Output (Within 3 mV)**
- **Micro Power: $I_Q = 23 \mu\text{A}/\text{Amplifier}$**

(1) Component qualification in accordance with JEDEC and industry standards to ensure reliable operation over an extended temperature range. This includes, but is not limited to, Highly Accelerated Stress Test (HAST) or biased 85/85, temperature cycle, autoclave or unbiased HAST, electromigration, bond intermetallic life, and mold compound life. Such qualification testing should not be viewed as justifying use of this component beyond specified performance and environmental limits.

- **Micro-Size Packages**
- **Low Offset Voltage: 500 μV Typical**
- **Specified From $V_S = 2.3 \text{ V}$ to 5.5 V**

APPLICATIONS

- **Battery-Powered Instruments**
- **Portable Devices**
- **High-Impedance Applications**
- **Photodiode Preamplifiers**
- **Precision Integrators**
- **Medical Instruments**
- **Test Equipment**

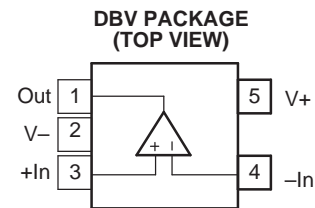

DESCRIPTION/ORDERING INFORMATION

The OPA336 micro-power CMOS operational amplifier (MicroAmplifier™ series) is designed for battery-powered applications. The device operates on a single supply, with operation as low as 2.1 V. The output is rail to rail and swings to within 3 mV of the supplies with a 100-k Ω load. The common-mode range extends to the negative supply — ideal for single-supply applications.

In addition to small size and low quiescent current (23 $\mu\text{A}/\text{amplifier}$), the OPA336 features low offset voltage (500 μV typical), low input bias current (1 pA), and high open-loop gain (115 dB).

The device is packaged in the tiny DBV (SOT23-5) surface-mount package. It operates from –55°C to 125°C. A macromodel is available for download (at www.ti.com) for design analysis.

ORDERING INFORMATION

T_A	PACKAGE	ORDERABLE PART NUMBER	TOP-SIDE MARKING
–55°C to 125°C	DBV – SOT23-5	OPA336MDBVREP	OAYM



ELECTROSTATIC DISCHARGE SENSITIVITY

This integrated circuit can be damaged by ESD. Texas Instruments recommends that all integrated circuits be handled with appropriate precautions. Failure to observe proper handling and installation procedures can cause damage.

ESD damage can range from subtle performance degradation to complete device failure. Precision integrated circuits may be more susceptible to damage because very small parametric changes could cause the device not to meet its published specifications.



Please be aware that an important notice concerning availability, standard warranty, and use in critical applications of Texas Instruments semiconductor products and disclaimers thereto appears at the end of this data sheet.

MicroAmplifier is a trademark of Texas Instruments.

OPA336-EP
SINGLE-SUPPLY MICRO-POWER CMOS OPERATIONAL AMPLIFIER
MicroAmplifier™ SERIES

SCES658–JUNE 2006

Absolute Maximum Ratings⁽¹⁾

		MIN	MAX	UNIT
Supply voltage			7.5	V
Signal input terminals	Voltage range ⁽²⁾	(V–) – 0.3	(V+) + 0.3	V
	Current ⁽²⁾		10	mA
Output short circuit ⁽³⁾			Continuous	
T _A	Operating free-air temperature range	–55	125	°C
T _{stg}	Storage temperature range	–55	125	°C
T _J	Junction temperature		150	°C
Lead temperature (soldering, 10 s)			300	°C
ESD rating	Charged-Device Model (CDM)		1000	
	Human-Body Model (HBM)		500	V
	Machine Model (MM)		100	
θ _{JA}	Package thermal impedance		200	°C/W

- (1) Stresses beyond those listed under "absolute maximum ratings" may cause permanent damage to the device. These are stress ratings only, and functional operation of the device at these or any other conditions beyond those indicated under "recommended operating conditions" is not implied. Exposure to absolute-maximum-rated conditions for extended periods may affect device reliability.
- (2) Input terminals are diode clamped to the power-supply rails. Input signals that can swing more than 0.3 V beyond the supply rails should be current limited to 10 mA or less.
- (3) Short circuit to ground, one amplifier per package

Electrical Characteristics

 over recommended operating temperature range, $V_S = 2.3\text{ V to }5.5\text{ V}$, $T_A = 25^\circ\text{C}$, $V_S = 5\text{ V}$, $R_L = 25\text{ k}\Omega$ connected to $V_S/2$ (unless otherwise noted)

PARAMETER		TEST CONDITIONS	MIN	TYP	MAX	UNIT
Offset Voltage						
V_{OS}	Input offset voltage				± 500	μV
	Input offset voltage overtemperature ⁽¹⁾				± 950	
PSRR	Input offset voltage vs power supply	$V_S = 2.3\text{ V to }5.5\text{ V}$		25	100	$\mu\text{V/V}$
	Overtemperature ⁽¹⁾				150	
	Channel separation, dc			0.1		
Input Bias Current						
I_B	Input bias current			± 1	± 10	pA
	Overtemperature ⁽¹⁾				± 200	
I_{OS}	Input offset current			± 1	± 60	pA
Noise						
	Input voltage noise	$f = 0.1\text{ Hz to }10\text{ Hz}$		3		$\mu\text{Vp-p}$
e_n	Input voltage noise density	$f = 1\text{ kHz}$		40		$\text{nV}/\sqrt{\text{Hz}}$
i_n	Current noise density	$f = 1\text{ kHz}$		30		$\text{fA}/\sqrt{\text{Hz}}$
Input Voltage Range						
V_{CM}	Common-mode voltage range		-0.2		$(V+) - 1$	V
CMRR	Common-mode rejection ratio	$-0.2\text{ V} < V_{CM} < (V+) - 1\text{ V}$	76	86		dB
	Overtemperature ⁽¹⁾		72			
Input Impedance						
	Differential input impedance			$10^{13} \parallel 2$		$\Omega \parallel \text{pF}$
	Common mode input impedance			$10^{13} \parallel 4$		$\Omega \parallel \text{pF}$
Open-Loop Gain						
A_{OL}	Open-loop voltage gain	$R_L = 25\text{ k}\Omega$, $100\text{ mV} < V_O < (V+) - 100\text{ mV}$	90			dB
		$R_L = 5\text{ k}\Omega$, $500\text{ mV} < V_O < (V+) - 500\text{ mV}$	90			
	Overtemperature ⁽¹⁾	$R_L = 25\text{ k}\Omega$, $100\text{ mV} < V_O < (V+) - 100\text{ mV}$	82			
		$R_L = 5\text{ k}\Omega$, $500\text{ mV} < V_O < (V+) - 500\text{ mV}$	89			
Frequency Response						
GBW	Gain-bandwidth product	$V_S = 5\text{ V}$, $G = 1$		100		kHz
SR	Slew rate	$V_S = 5\text{ V}$, $G = 1$		0.03		$\text{V}/\mu\text{s}$
	Overload recovery time	$V_{IN} \times G = V_S$		100		μs

 (1) Limits apply over the specified temperature range, $T_A = -55^\circ\text{C to }125^\circ\text{C}$.

OPA336-EP
SINGLE-SUPPLY MICRO-POWER CMOS OPERATIONAL AMPLIFIER
MicroAmplifier™ SERIES

SCES658–JUNE 2006

Electrical Characteristics (continued)

over recommended operating temperature range, $V_S = 2.3\text{ V to }5.5\text{ V}$, $T_A = 25^\circ\text{C}$, $V_S = 5\text{ V}$, $R_L = 25\text{ k}\Omega$ connected to $V_S/2$ (unless otherwise noted)

PARAMETER		TEST CONDITIONS	MIN	TYP	MAX	UNIT
Output						
Voltage output swing from rail ⁽²⁾		$R_L = 100\text{ k}\Omega$, $A_{OL} \geq 70\text{ dB}$		3		mV
		$R_L = 25\text{ k}\Omega$, $A_{OL} \geq 90\text{ dB}$		20	100	
		$R_L = 5\text{ k}\Omega$, $A_{OL} \geq 90\text{ dB}$		70	500	
Overtemperature ⁽³⁾		$R_L = 25\text{ k}\Omega$, $A_{OL} \geq 82\text{ dB}$			100	mV
		$R_L = 5\text{ k}\Omega$, $A_{OL} \geq 89\text{ dB}$			500	
I_{SC}	Short-circuit current			± 5		mA
C_{LOAD}	Capacitive load drive ⁽⁴⁾					
Power Supply						
V_S	Specified voltage range		2.3		5.5	V
	Minimum operating voltage			2.1		V
I_Q	Quiescent current (per amplifier)	$I_O = 0$		23	35	μA
	Overtemperature ⁽³⁾				38	

(2) Output voltage swings are measured between the output and positive and negative power-supply rails.

(3) Limits apply over the specified temperature range, $T_A = -55^\circ\text{C}$ to 125°C .

(4) See Capacitive Load and Stability section

TYPICAL CHARACTERISTICS

$T_A = 25^\circ\text{C}$, $V_S = 5\text{ V}$, $R_L = 25\text{ k}\Omega$ connected to $V_S/2$ (unless otherwise noted)

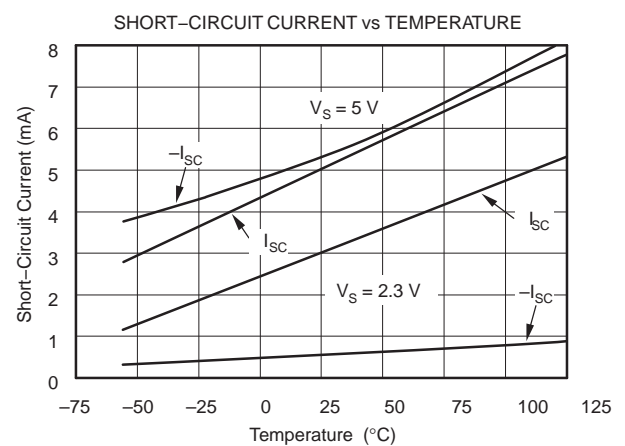
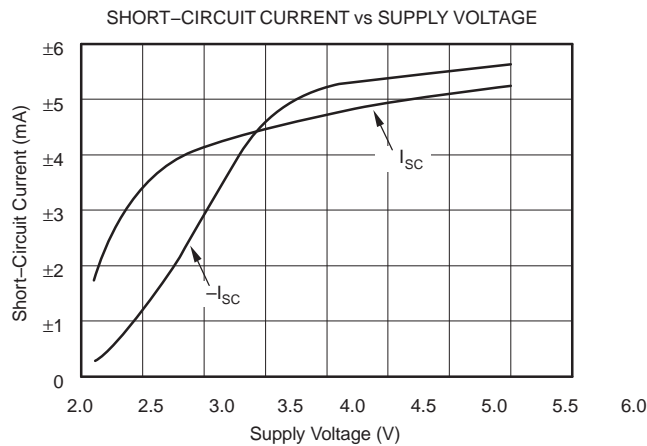
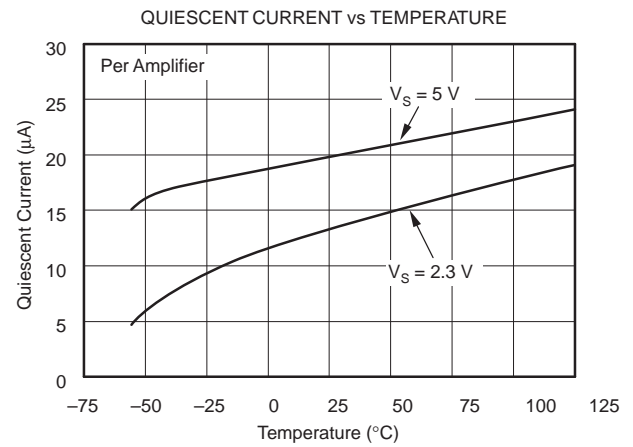
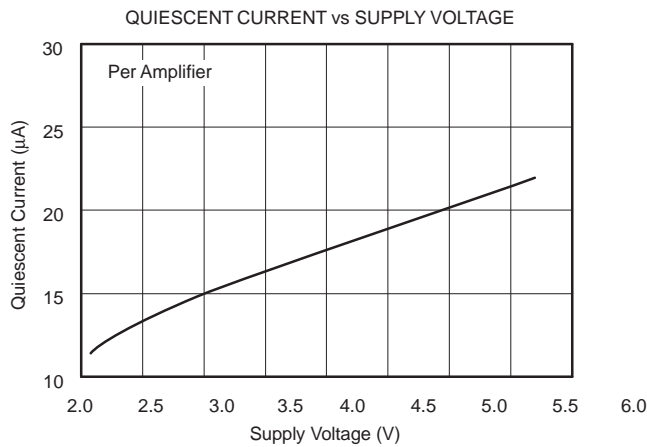
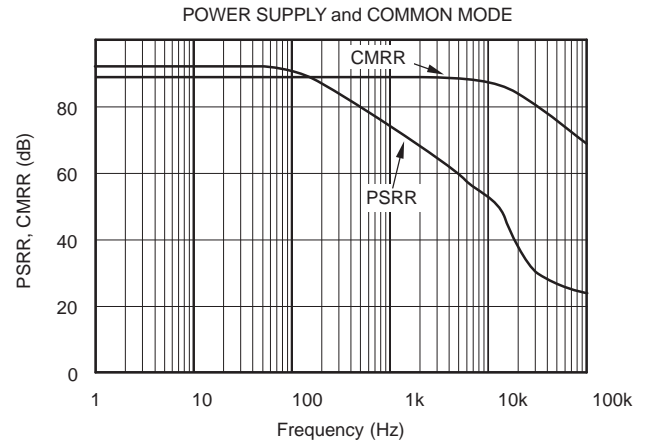
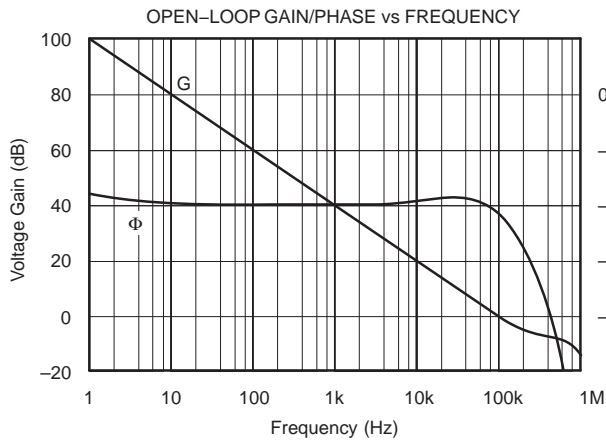

TYPICAL CHARACTERISTICS (continued)

$T_A = 25^\circ\text{C}$, $V_S = 5\text{ V}$, $R_L = 25\text{ k}\Omega$ connected to $V_S/2$ (unless otherwise noted)

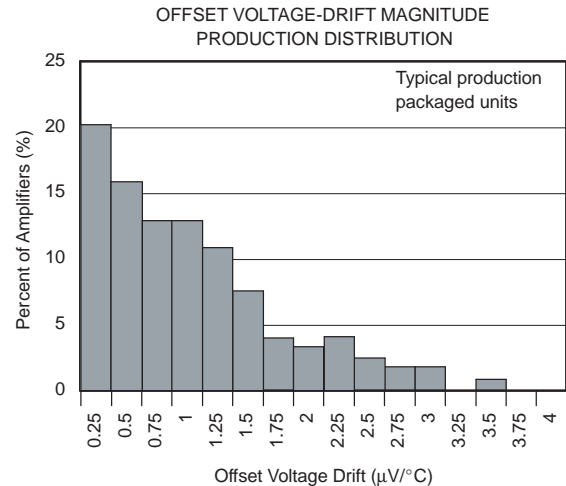
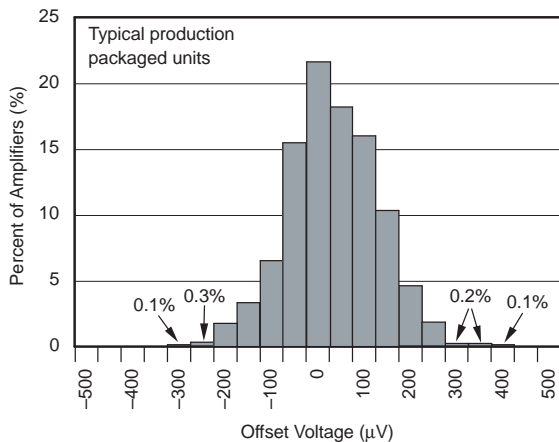
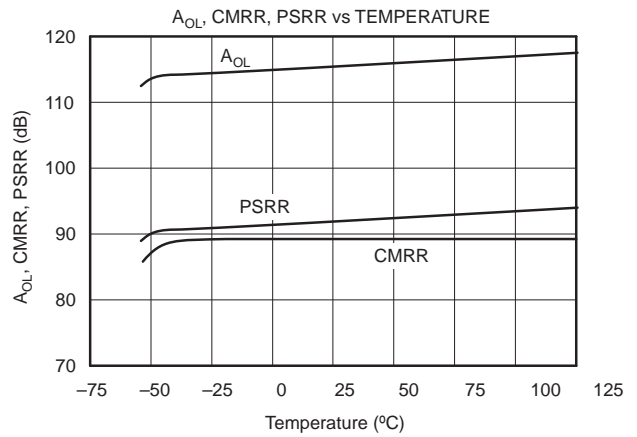
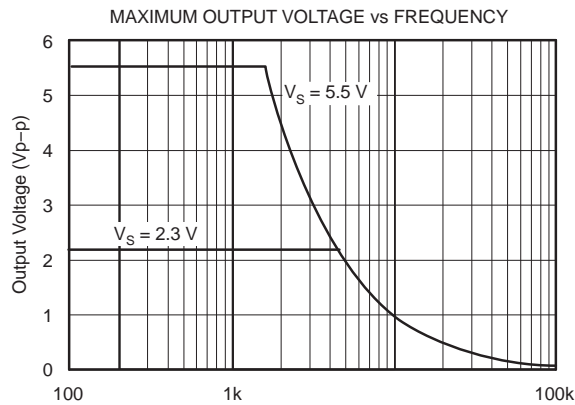
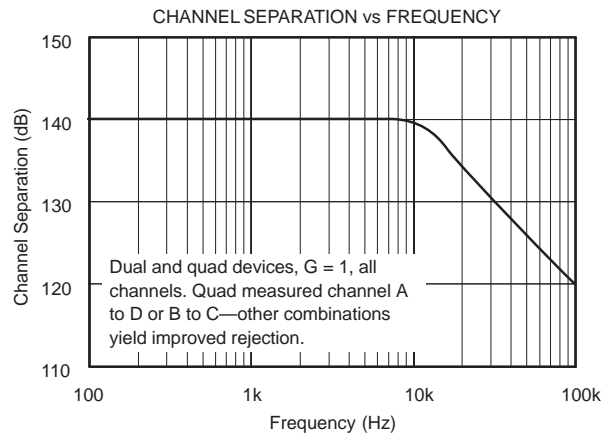
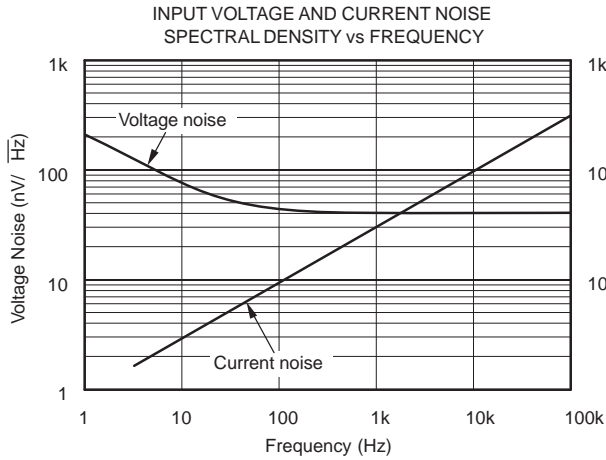

TYPICAL CHARACTERISTICS (continued)

$T_A = 25^\circ\text{C}$, $V_S = 5\text{ V}$, $R_L = 25\text{ k}\Omega$ connected to $V_S/2$ (unless otherwise noted)

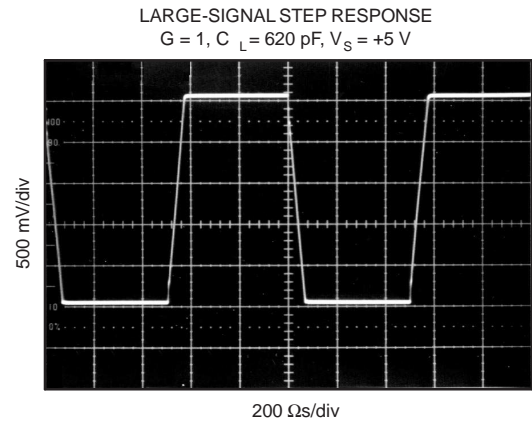
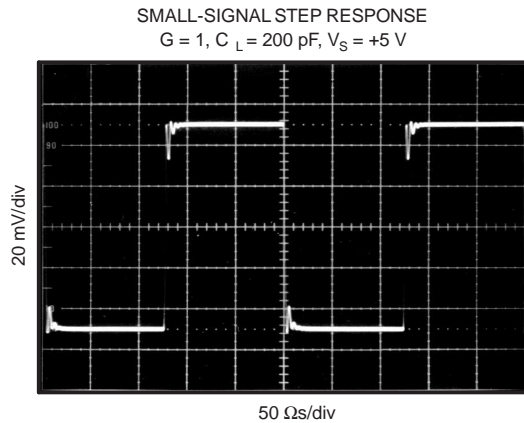
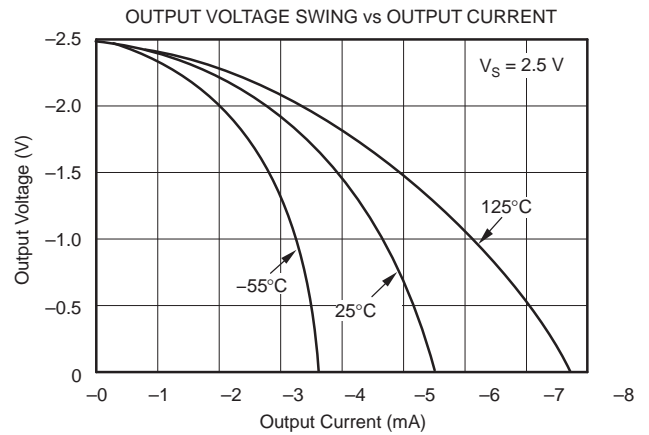
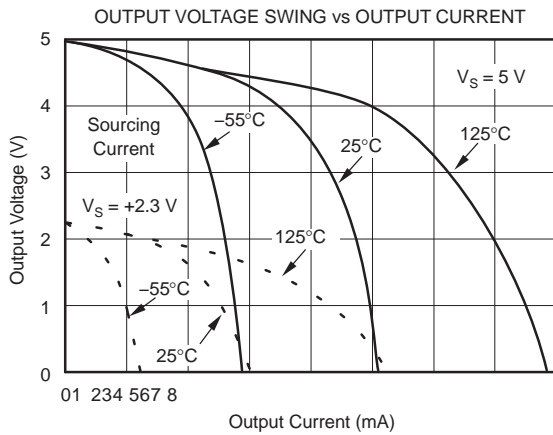
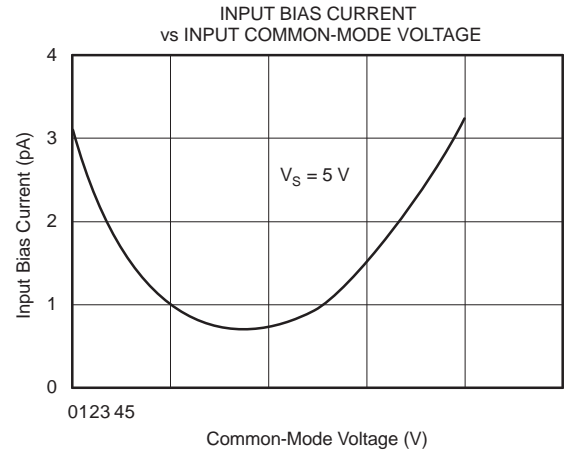
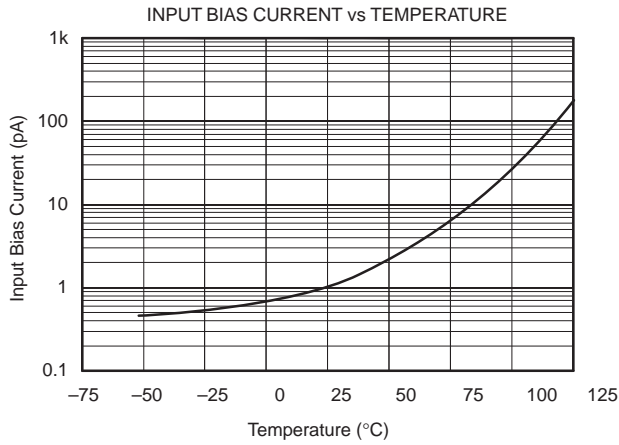

APPLICATION INFORMATION

The OPA336 operational amplifier is fabricated with a state-of-the-art 0.6-micron CMOS process. The device is unity-gain stable and suitable for a wide range of general-purpose applications. Power-supply pins should be bypassed with 0.01- μ F ceramic capacitors. The OPA336 is protected against reverse battery voltages.

Operating Voltage

The OPA336 can operate from a 2.1-V to 5.5-V single supply voltage, with excellent performance. Most behavior remains unchanged throughout the full operating voltage range. Parameters that vary significantly with operating voltage are shown in the typical characteristics. The OPA336 is fully specified for operation from 2.3 V to 5.5 V; a single limit applies over the supply range. In addition, many parameters are ensured over the specified temperature range, -55°C to 125°C .

Input Voltage

The input common-mode range of the OPA336 extends from $(V-) - 0.2\text{ V}$ to $(V+) - 1\text{ V}$. For normal operation, inputs should be limited to this range. The absolute maximum input voltage is 300 mV beyond the supplies. Thus, inputs greater than the input common-mode range, but less than maximum input voltage, while not valid, will not cause any damage to the operational amplifier. Furthermore, the inputs may go beyond the power supplies without phase inversion (see [Figure 1](#)), unlike some other operational amplifiers.

Normally, input bias current is approximately 1 pA. However, input voltages exceeding the power supplies can cause excessive current to flow in or out of the input pins. Momentary voltages greater than the power supply can be tolerated, as long as the current on the input pins is limited to 10 mA. This is easily accomplished with an input resistor (see [Figure 2](#)).

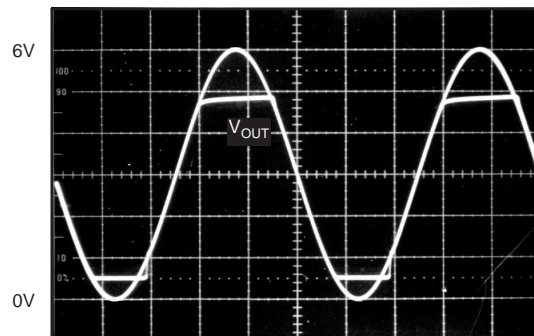

**Figure 1. No Phase Inversion
With Inputs Greater Than Power-Supply Voltage**

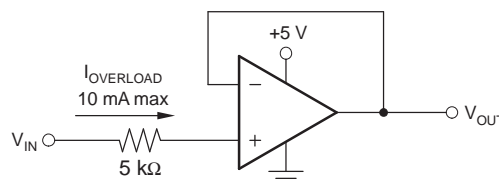

**Figure 2. Input Current Protection
for Voltages Exceeding Power-Supply Voltage**

APPLICATION INFORMATION (CONTINUED)

Capacitive Load and Stability

The OPA336 can drive a wide range of capacitive loads. However, all operational amplifiers, under certain conditions, may become unstable. Operational amplifier configuration, gain, and load value are just a few of the factors to consider when determining stability.

When properly configured, the OPA336 drives approximately 10,000 pF. An operational amplifier in unity-gain configuration is the most vulnerable to capacitive load. The capacitive load reacts with the operational amplifier output resistance along with any additional load resistance to create a pole in the response, which degrades the phase margin. In unity gain, the OPA336 performs well with a pure capacitive load, up to about 300 pF. Increasing gain enhances the amplifier's ability to drive loads beyond this level.

One method of improving capacitive load drive in the unity-gain configuration is to insert a 50-Ω to 100-Ω resistor inside the feedback loop (see [Figure 3](#)). This reduces ringing with large capacitive loads, while maintaining direct current (DC) accuracy. For example, with $R_L = 25\text{ k}\Omega$, OPA336 performs well with capacitive loads in excess of 1000 pF (see [Figure 4](#)). Without the OPA336 R_S , capacitive load drive typically is 350 pF for these conditions (see [Figure 5](#)).

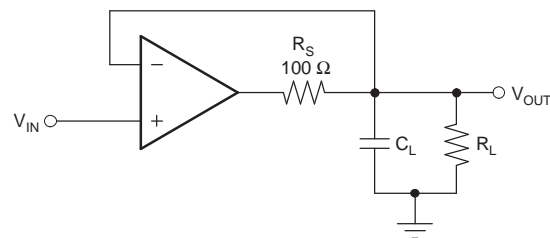

Figure 3. Series Resistor in Unity-Gain Configuration Improves Capacitive Load Drive

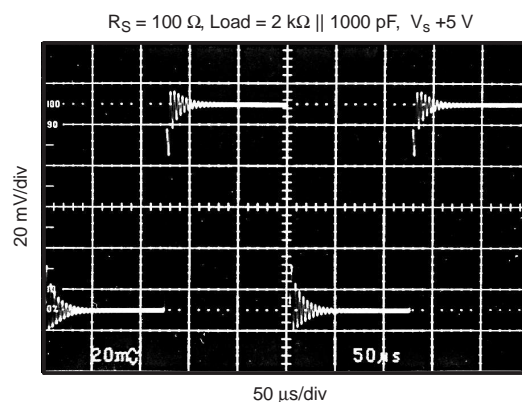

Figure 4. Small-Signal Step Response Using Series Resistor to Improve Capacitive Load Drive

APPLICATION INFORMATION (CONTINUED)

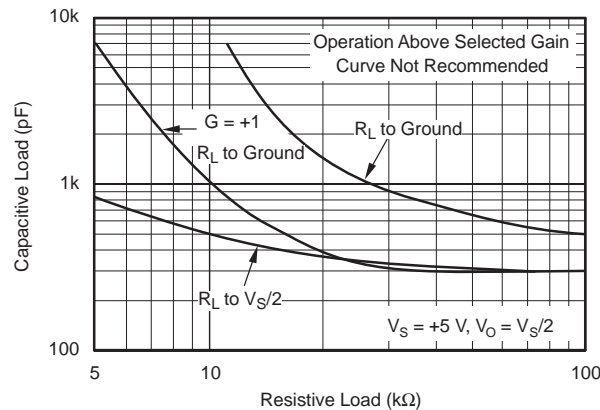

Figure 5. Stability — Capacitive Load vs Resistive Load

Alternatively, the resistor may be connected in series with the output outside of the feedback loop. However, if there is a resistive load parallel to the capacitive load, it and the series resistor create a voltage divider. This introduces a DC error at the output; however, this error may be insignificant. For instance, with $R_L = 100\text{ k}\Omega$ and $R_S = 100\ \Omega$, there is only about a 0.1% error at the output.

Figure 5 shows the recommended operating regions for the OPA336. Decreasing the load resistance generally improves capacitive load drive. Figure 5 also shows how stability differs, depending on where the resistive load is connected. With $G = 1$ and $R_L = 10\text{ k}\Omega$ connected to $V_S/2$, the OPA336 typically can drive 500 pF. Connecting the same load to ground improves capacitive load drive to 1000 pF.

PACKAGING INFORMATION

Orderable Device	Status ⁽¹⁾	Package Type	Package Drawing	Pins	Package Qty	Eco Plan ⁽²⁾	Lead/Ball Finish	MSL Peak Temp ⁽³⁾
OPA336MDBVREP	ACTIVE	SOT-23	DBV	5	3000	Green (RoHS & no Sb/Br)	Call TI	Level-2-260C-1 YEAR
V62/06641-01XE	ACTIVE	SOT-23	DBV	5	3000	Green (RoHS & no Sb/Br)	Call TI	Level-2-260C-1 YEAR

⁽¹⁾ The marketing status values are defined as follows:

ACTIVE: Product device recommended for new designs.

LIFEBUY: TI has announced that the device will be discontinued, and a lifetime-buy period is in effect.

NRND: Not recommended for new designs. Device is in production to support existing customers, but TI does not recommend using this part in a new design.

PREVIEW: Device has been announced but is not in production. Samples may or may not be available.

OBsolete: TI has discontinued the production of the device.

⁽²⁾ Eco Plan - The planned eco-friendly classification: Pb-Free (RoHS), Pb-Free (RoHS Exempt), or Green (RoHS & no Sb/Br) - please check <http://www.ti.com/productcontent> for the latest availability information and additional product content details.

TBD: The Pb-Free/Green conversion plan has not been defined.

Pb-Free (RoHS): TI's terms "Lead-Free" or "Pb-Free" mean semiconductor products that are compatible with the current RoHS requirements for all 6 substances, including the requirement that lead not exceed 0.1% by weight in homogeneous materials. Where designed to be soldered at high temperatures, TI Pb-Free products are suitable for use in specified lead-free processes.

Pb-Free (RoHS Exempt): This component has a RoHS exemption for either 1) lead-based flip-chip solder bumps used between the die and package, or 2) lead-based die adhesive used between the die and leadframe. The component is otherwise considered Pb-Free (RoHS compatible) as defined above.

Green (RoHS & no Sb/Br): TI defines "Green" to mean Pb-Free (RoHS compatible), and free of Bromine (Br) and Antimony (Sb) based flame retardants (Br or Sb do not exceed 0.1% by weight in homogeneous material)

⁽³⁾ MSL, Peak Temp. -- The Moisture Sensitivity Level rating according to the JEDEC industry standard classifications, and peak solder temperature.

Important Information and Disclaimer:The information provided on this page represents TI's knowledge and belief as of the date that it is provided. TI bases its knowledge and belief on information provided by third parties, and makes no representation or warranty as to the accuracy of such information. Efforts are underway to better integrate information from third parties. TI has taken and continues to take reasonable steps to provide representative and accurate information but may not have conducted destructive testing or chemical analysis on incoming materials and chemicals. TI and TI suppliers consider certain information to be proprietary, and thus CAS numbers and other limited information may not be available for release.

In no event shall TI's liability arising out of such information exceed the total purchase price of the TI part(s) at issue in this document sold by TI to Customer on an annual basis.

OTHER QUALIFIED VERSIONS OF OPA336-EP :

- Catalog: [OPA336](#)

NOTE: Qualified Version Definitions:

- Catalog - TI's standard catalog product

TAPE AND REEL INFORMATION

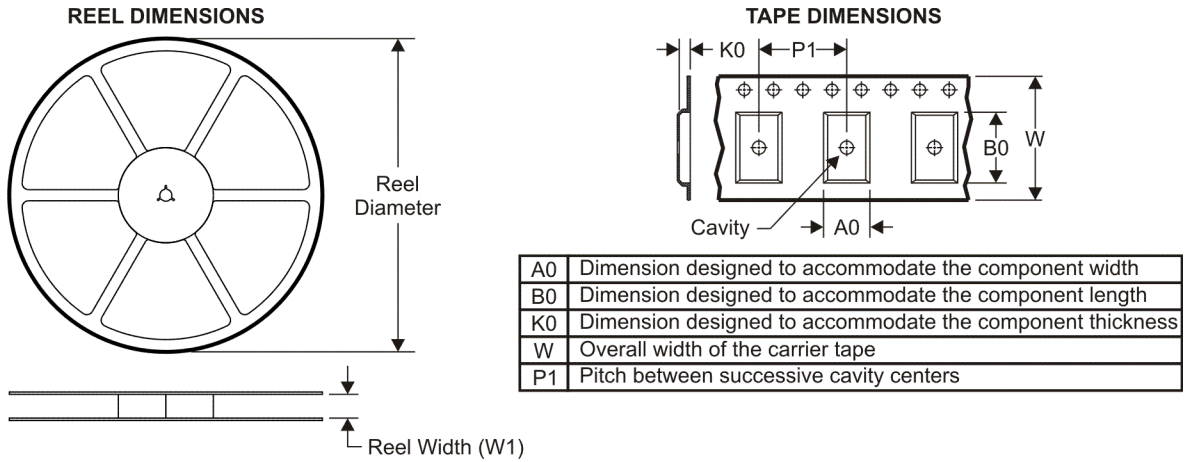

QUADRANT ASSIGNMENTS FOR PIN 1 ORIENTATION IN TAPE



*All dimensions are nominal

Device	Package Type	Package Drawing	Pins	SPQ	Reel Diameter (mm)	Reel Width W1 (mm)	A0 (mm)	B0 (mm)	K0 (mm)	P1 (mm)	W (mm)	Pin1 Quadrant
OPA336MDBVREP	SOT-23	DBV	5	3000	179.0	8.4	3.2	3.2	1.4	4.0	8.0	Q3

TAPE AND REEL BOX DIMENSIONS



*All dimensions are nominal

Device	Package Type	Package Drawing	Pins	SPQ	Length (mm)	Width (mm)	Height (mm)
OPA336MDBVREP	SOT-23	DBV	5	3000	195.0	200.0	45.0

DBV (R-PDSO-G5)

PLASTIC SMALL-OUTLINE PACKAGE

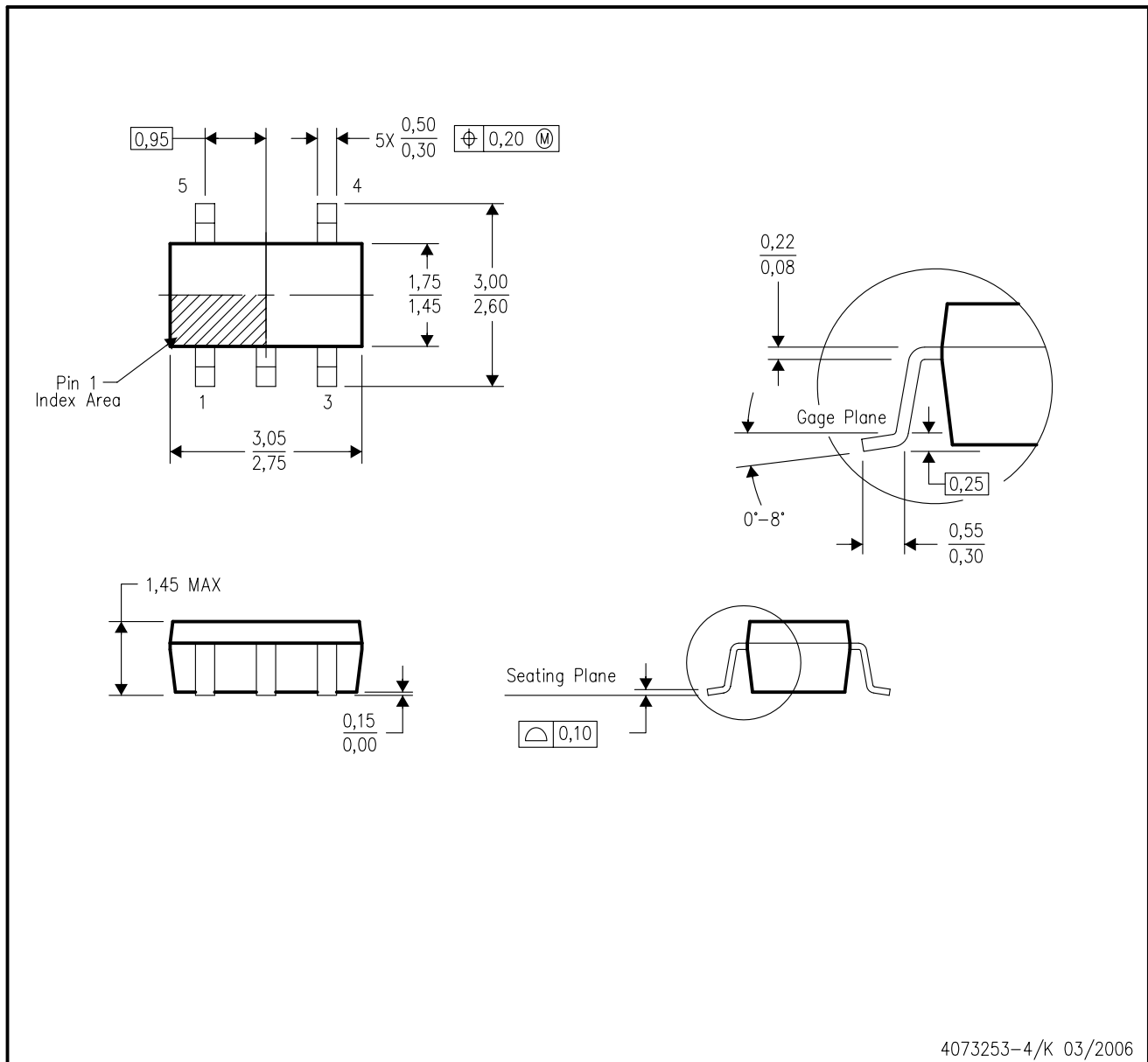

- NOTES:
- A. All linear dimensions are in millimeters.
 - B. This drawing is subject to change without notice.
 - C. Body dimensions do not include mold flash or protrusion. Mold flash and protrusion shall not exceed 0.15 per side.
 - D. Falls within JEDEC MO-178 Variation AA.

IMPORTANT NOTICE

Texas Instruments Incorporated and its subsidiaries (TI) reserve the right to make corrections, modifications, enhancements, improvements, and other changes to its products and services at any time and to discontinue any product or service without notice. Customers should obtain the latest relevant information before placing orders and should verify that such information is current and complete. All products are sold subject to TI's terms and conditions of sale supplied at the time of order acknowledgment.

TI warrants performance of its hardware products to the specifications applicable at the time of sale in accordance with TI's standard warranty. Testing and other quality control techniques are used to the extent TI deems necessary to support this warranty. Except where mandated by government requirements, testing of all parameters of each product is not necessarily performed.

TI assumes no liability for applications assistance or customer product design. Customers are responsible for their products and applications using TI components. To minimize the risks associated with customer products and applications, customers should provide adequate design and operating safeguards.

TI does not warrant or represent that any license, either express or implied, is granted under any TI patent right, copyright, mask work right, or other TI intellectual property right relating to any combination, machine, or process in which TI products or services are used. Information published by TI regarding third-party products or services does not constitute a license from TI to use such products or services or a warranty or endorsement thereof. Use of such information may require a license from a third party under the patents or other intellectual property of the third party, or a license from TI under the patents or other intellectual property of TI.

Reproduction of TI information in TI data books or data sheets is permissible only if reproduction is without alteration and is accompanied by all associated warranties, conditions, limitations, and notices. Reproduction of this information with alteration is an unfair and deceptive business practice. TI is not responsible or liable for such altered documentation. Information of third parties may be subject to additional restrictions.

Resale of TI products or services with statements different from or beyond the parameters stated by TI for that product or service voids all express and any implied warranties for the associated TI product or service and is an unfair and deceptive business practice. TI is not responsible or liable for any such statements.

TI products are not authorized for use in safety-critical applications (such as life support) where a failure of the TI product would reasonably be expected to cause severe personal injury or death, unless officers of the parties have executed an agreement specifically governing such use. Buyers represent that they have all necessary expertise in the safety and regulatory ramifications of their applications, and acknowledge and agree that they are solely responsible for all legal, regulatory and safety-related requirements concerning their products and any use of TI products in such safety-critical applications, notwithstanding any applications-related information or support that may be provided by TI. Further, Buyers must fully indemnify TI and its representatives against any damages arising out of the use of TI products in such safety-critical applications.

TI products are neither designed nor intended for use in military/aerospace applications or environments unless the TI products are specifically designated by TI as military-grade or "enhanced plastic." Only products designated by TI as military-grade meet military specifications. Buyers acknowledge and agree that any such use of TI products which TI has not designated as military-grade is solely at the Buyer's risk, and that they are solely responsible for compliance with all legal and regulatory requirements in connection with such use.

TI products are neither designed nor intended for use in automotive applications or environments unless the specific TI products are designated by TI as compliant with ISO/TS 16949 requirements. Buyers acknowledge and agree that, if they use any non-designated products in automotive applications, TI will not be responsible for any failure to meet such requirements.

Following are URLs where you can obtain information on other Texas Instruments products and application solutions:

Products

Amplifiers	amplifier.ti.com
Data Converters	dataconverter.ti.com
DLP® Products	www.dlp.com
DSP	dsp.ti.com
Clocks and Timers	www.ti.com/clocks
Interface	interface.ti.com
Logic	logic.ti.com
Power Mgmt	power.ti.com
Microcontrollers	microcontroller.ti.com
RFID	www.ti-rfid.com
RF/IF and ZigBee® Solutions	www.ti.com/lprf

Applications

Audio	www.ti.com/audio
Automotive	www.ti.com/automotive
Broadband	www.ti.com/broadband
Digital Control	www.ti.com/digitalcontrol
Medical	www.ti.com/medical
Military	www.ti.com/military
Optical Networking	www.ti.com/opticalnetwork
Security	www.ti.com/security
Telephony	www.ti.com/telephony
Video & Imaging	www.ti.com/video
Wireless	www.ti.com/wireless

Mailing Address: Texas Instruments, Post Office Box 655303, Dallas, Texas 75265
Copyright © 2009, Texas Instruments Incorporated

Looking for pricing, stock, or lifecycle information?

Click below to explore more details on WIN SOURCE:

 [View OPA336MDBVREP](#) on WIN SOURCE

 [Texas Instruments](#) Information

Optimize Your Supply Chain with WIN SOURCE Solutions

-  Global Sourcing Solution
-  Obsolete Management
-  Cost Control Management
-  Shortage Management
-  Alternative Solution
-  Excess Inventory Management