



**THE DATASHEET OF  
MC33341DG**



# MC33341

## Power Supply Battery Charger Regulation Control Circuit

The MC33341 is a monolithic regulation control circuit that is specifically designed to close the voltage and current feedback loops in power supply and battery charger applications. This device features the unique ability to perform source high-side, load high-side, source low-side and load low-side current sensing, each with either an internally fixed or externally adjustable threshold. The various current sensing modes are accomplished by a means of selectively using the internal differential amplifier, inverting amplifier, or a direct input path. Positive voltage sensing is performed by an internal voltage amplifier. The voltage amplifier threshold is internally fixed and can be externally adjusted in all low-side current sensing applications. An active high drive output is provided to directly interface with economical optoisolators for isolated output power systems. This device is available in 8-lead dual-in-line and surface mount packages.

### Features

- Differential Amplifier for High-Side Source and Load Current Sensing
- Inverting Amplifier for Source Return Low-Side Current Sensing
- Non-Inverting Input Path for Load Low-Side Current Sensing
- Fixed or Adjustable Current Threshold in All Current Sensing Modes
- Positive Voltage Sensing in All Current Sensing Modes
- Fixed Voltage Threshold in All Current Sensing Modes
- Adjustable Voltage Threshold in All Low-Side Current Sensing Modes
- Output Driver Directly Interfaces with Economical Optoisolators
- Operating Voltage Range of 2.3 V to 16 V
- Pb-Free Packages are Available

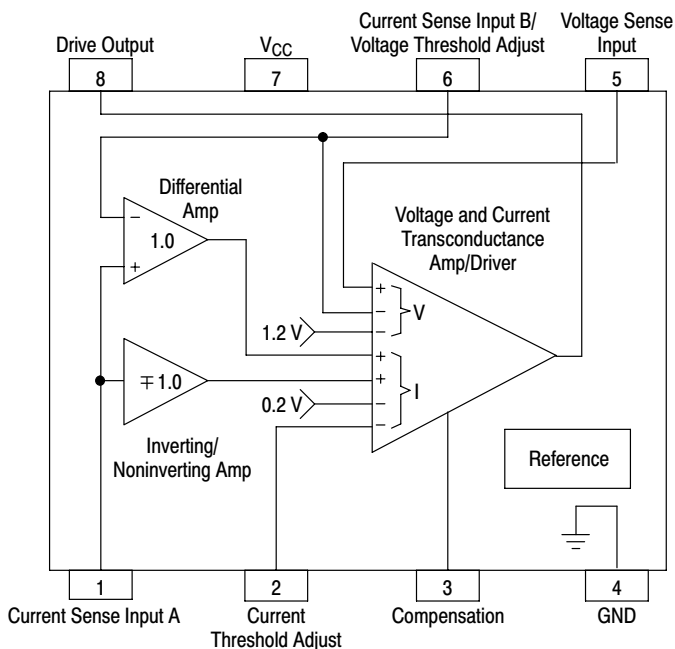

This device contains 114 active transistors.

Figure 1. Representative Block Diagram



ON Semiconductor®

<http://onsemi.com>

### MARKING DIAGRAMS



SOIC-8  
D SUFFIX  
CASE 751

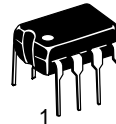
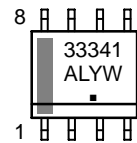

PDIP-8  
P SUFFIX  
CASE 626

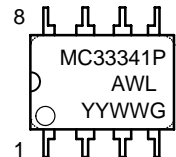

A = Assembly Location  
L, WL = Wafer Lot  
Y, YY = Year  
W, WW = Work Week  
▪ or G = Pb-Free Package  
(Note: Microdot may be in either location)

### PIN CONNECTIONS

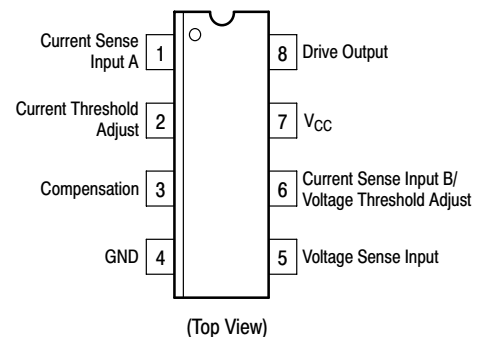

### ORDERING INFORMATION

See detailed ordering and shipping information in the package dimensions section on page 17 of this data sheet.

# MC33341

## MAXIMUM RATINGS

Rating	Symbol	Value	Unit
Power Supply Voltage (Pin 7)	$V_{CC}$	16	V
Voltage Range Current Sense Input A (Pin 1) Current Threshold Adjust (Pin 2) Compensation (Pin 3) Voltage Sense Input (Pin 5) Current Sense Input B / Voltage Threshold Adjust (Pin 6) Drive Output (Pin 8)	$V_{IR}$	-1.0 to $V_{CC}$	V
Drive Output Source Current (Pin 8)	$I_{Source}$	50	mA
Thermal Resistance, Junction-to-Air P Suffix, DIP Plastic Package, Case 626 D Suffix, SO-8 Plastic Package, Case 751	$R_{\theta JA}$	100 178	°C/W
Operating Junction Temperature (Note 1)	$T_J$	-25 to +150	°C
Storage Temperature	$T_{stg}$	-55 to +150	°C

NOTE: ESD data available upon request.

Stresses exceeding Maximum Ratings may damage the device. Maximum Ratings are stress ratings only. Functional operation above the Recommended Operating Conditions is not implied. Extended exposure to stresses above the Recommended Operating Conditions may affect device reliability.

1. Tested ambient temperature range for the MC33341:  $T_{low} = -25^{\circ}\text{C}$ ,  $T_{high} = +85^{\circ}\text{C}$ .

**ELECTRICAL CHARACTERISTICS** ( $V_{CC} = 6.0\text{ V}$ ,  $T_A = 25^{\circ}\text{C}$ , for min/max values  $T_A$  is the operating junction temperature range that applies (Note 1), unless otherwise noted.)

Characteristic	Symbol	Min	Typ	Max	Unit
<b>CURRENT SENSING</b> (Pins 1, 2, 6)					
High-Side Source and Load Sensing Pin 1 to Pin 6 (Pin 1 > 1.6 V) Internally Fixed Threshold Voltage (Pin 2 = $V_{CC}$ ) $T_A = 25^{\circ}\text{C}$ $T_A = T_{low}$ to $T_{high}$	$V_{th(I HS)}$	187 183	197 -	207 211	mV
Externally Adjusted Threshold Voltage (Pin 2 = 0 V) Externally Adjusted Threshold Voltage (Pin 2 = 200 mV)		- -	10 180	- -	
Low-Side Load Sensing Pin 1 to Pin 4 (Pin 1 = 0 V to 0.8 V) Internally Fixed Threshold Voltage (Pin 2 = $V_{CC}$ ) $T_A = 25^{\circ}\text{C}$ $T_A = T_{low}$ to $T_{high}$	$V_{th(I LS+)}$	194 192	200 -	206 208	mV
Externally Adjusted Threshold Voltage (Pin 2 = 0 V) Externally Adjusted Threshold Voltage (Pin 2 = 200 mV)		- -	10 180	- -	
Low-Side Source Return Sensing Pin 1 to 4 (Pin 1 = 0 V to -0.2 V) Internally Fixed Threshold Voltage (Pin 2 = $V_{CC}$ ) $T_A = 25^{\circ}\text{C}$ $T_A = T_{low}$ to $T_{high}$	$V_{th(I LS-)}$	-195 -193	-201 -	-207 -209	mV
Externally Adjusted Threshold Voltage (Pin 2 = 0 V) Externally Adjusted Threshold Voltage (Pin 2 = 200 mV)		- -	-10 -180	- -	
Current Sense Input A (Pin 1) Input Bias Current, High-Side Source and Load Sensing (Pin 2 = 0 V to $V_{Pin 6}$ V)	$I_{B(A HS)}$	-	40	-	$\mu\text{A}$
Input Bias Current, Low-Side Load Sensing (Pin 2 = 0 V to 0.8 V)	$I_{B(A LS+)}$	-	10	-	nA
Input Resistance, Low-Side Source Return Sensing (Pin 2 = -0.6 V to 0 V)	$R_{in(A LS-)}$	-	10	-	k $\Omega$
Current Sense Input B/Voltage Threshold Adjust (Pin 6) Input Bias Current High-Side Source and Load Current Sensing (Pin 6 > 2.0 V) Voltage Threshold Adjust (Pin 6 < 1.2 V)	$I_{B(B)}$	- -	20 100	- -	$\mu\text{A}$ nA
Current Sense Threshold Adjust (Pin 2) Input Bias Current	$I_{B(I th)}$	-	10	-	nA
Transconductance, Current Sensing Inputs to Drive Output	$g_{m(I)}$	-	6.0	-	mhos

# MC33341

**ELECTRICAL CHARACTERISTICS** ( $V_{CC} = 6.0\text{ V}$ ,  $T_A = 25^\circ\text{C}$ , for min/max values  $T_A$  is the operating junction temperature range that applies (Note 1), unless otherwise noted.)

Characteristic	Symbol	Min	Typ	Max	Unit
<b>DIFFERENTIAL AMPLIFIER DISABLE LOGIC</b> (Pins 1, 6)					
Logic Threshold Voltage Pin 1 (Pin 6 = 0 V) Enabled, High-Side Source and Load Current Sensing	$V_{th(I\ HS)}$	–	$\geq 1.7$	–	V
Disabled, Low-Side Load and Source Return Current Sensing	$V_{th(I\ LS)}$	–	$\leq 1.3$	–	
<b>VOLTAGE SENSING</b> (Pins 5, 6)					
Positive Sensing Pin 5 to Pin 4 Internally Fixed Threshold Voltage $T_A = 25^\circ\text{C}$	$V_{th(V)}$	1.186	1.210	1.234	V
$T_A = T_{low}$ to $T_{high}$		1.174	–	1.246	V
Externally Adjusted Threshold Voltage (Pin 6 = 0 V)		–	40	–	mV
Externally Adjusted Threshold Voltage (Pin 6 = 1.2 V)		–	1.175	–	V
Voltage Sense, Input Bias Current (Pin 5)	$I_{B(V)}$	–	10	–	nA
Transconductance, Voltage Sensing Inputs to Drive Output	$g_{m(V)}$	–	7.0	–	mhos
<b>DRIVE OUTPUT</b> (Pin 8)					
High State Source Voltage ( $I_{Source} = 10\text{ mA}$ )	$V_{OH}$	–	$V_{CC} - 0.8$	–	V
High State Source Current (Pin 8 = 0 V)	$I_{Source}$	15	20	–	mA
<b>TOTAL DEVICE</b> (Pin 7)					
Operating Voltage Range	$V_{CC}$	2.5 to 15	2.3 to 15	–	V
Power Supply Current ( $V_{CC} = 6.0\text{ V}$ )	$I_{CC}$	–	300	600	$\mu\text{A}$

## PIN FUNCTION DESCRIPTION

Pin	Name	Description
1	Current Sense Input A	This multi-mode current sensing input can be used for either source high-side, load high-side, source-return low-side, or load low-side sensing. It is common to a Differential Amplifier, Inverting Amplifier, and a Noninverting input path. Each of these sensing paths indirectly connect to the current sense input of the Transconductance Amplifier. This input is connected to the high potential side of a current sense resistor when used in source high-side, load high-side, or load low-side current sensing modes. In source return low-side current sensing mode, this pin connects to the low potential side of a current sense resistor.
2	Current Threshold Adjust	The current sense threshold can be externally adjusted over a range of 0 V to 200 mV with respect to Pin 4, or internally fixed at 200 mV by connecting Pin 2 to $V_{CC}$ .
3	Compensation	This pin is connected to a high impedance node within the transconductance amplifier and is made available for loop compensation. It can also be used as an input to directly control the Drive Output. An active low at this pin will force the Drive Output into a high state.
4	Ground	This pin is the regulation control IC ground. The control threshold voltages are with respect to this pin.
5	Voltage Sense Input	This is the voltage sensing input of the Transconductance Amplifier. It is normally connected to the power supply/battery charger output through a resistor divider. The input threshold is controlled by Pin 6.
6	Current Sense Input B / Voltage Threshold Adjust	This is a dual function input that is used for either high-side current sensing, or as a voltage threshold adjustment for Pin 5. This input is connected to the low potential side of a current sense resistor when used in source high-side or load high-side current sensing modes. In all low-side current sensing modes, Pin 6 is available as a voltage threshold adjustment for Pin 5. The threshold can be externally adjusted over a range of 0 V to 1.2 V with respect to Pin 4, or internally fixed at 1.2 V by connecting Pin 6 to $V_{CC}$ .
7	$V_{CC}$	This is the positive supply voltage for the regulation control IC. The typical operating voltage range is 2.3 V to 15 V with respect to Pin 4.
8	Drive Output	This is a source-only output that normally connects to a linear or switching regulator control circuit. This output is capable of 15 mA, allowing it to directly drive an optoisolator in primary side control applications where galvanic isolation is required.

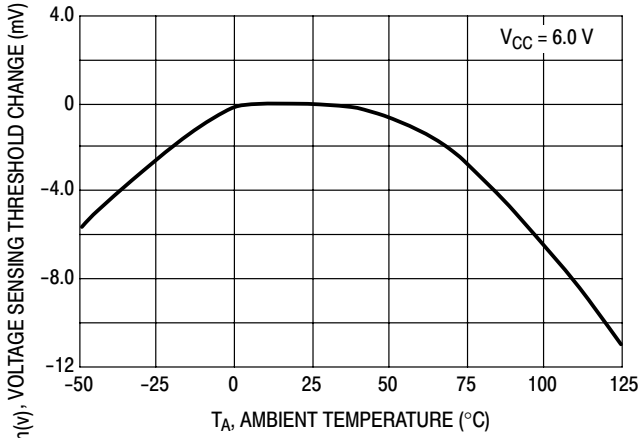

**Figure 2. Voltage Sensing Threshold Change versus Temperature**

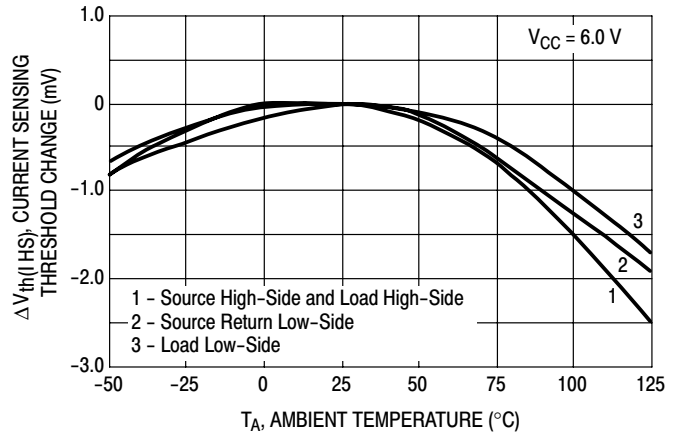

**Figure 3. Current Sensing Threshold Change versus Temperature**

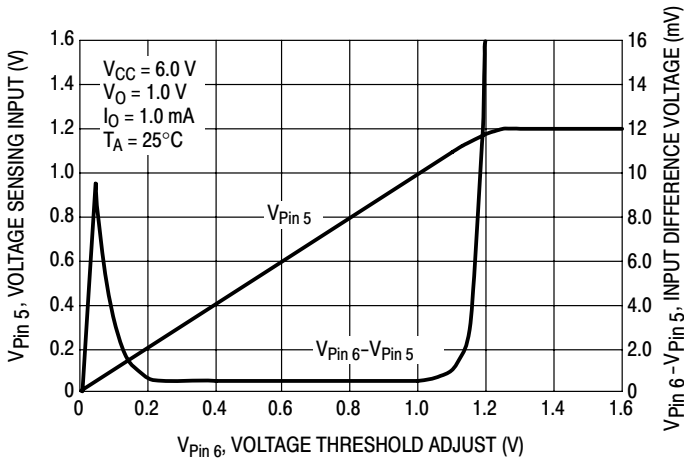

**Figure 4. Closed-Loop Voltage Sensing Input versus Voltage Threshold Adjust**

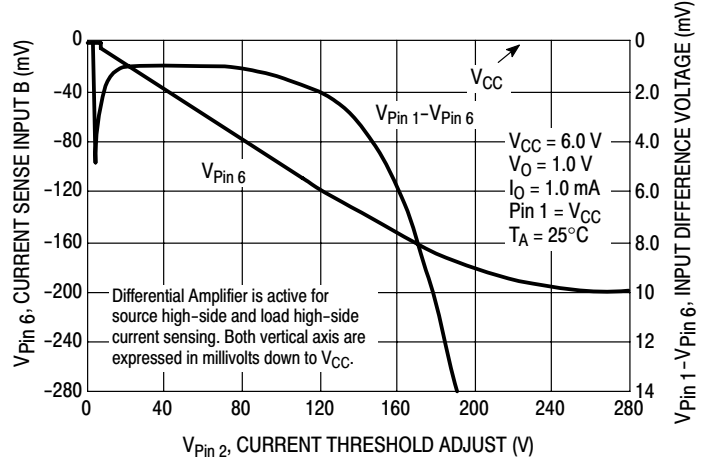

**Figure 5. Closed-Loop Current Sense Input B versus Current Threshold Adjust**

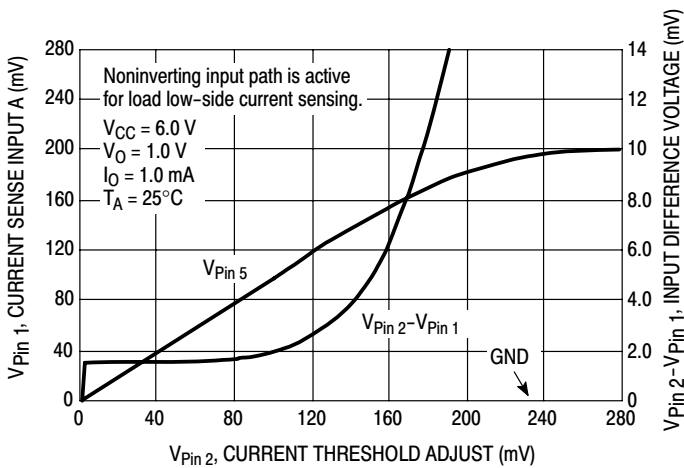

**Figure 6. Closed-Loop Current Sensing Input A versus Current Threshold Adjust**

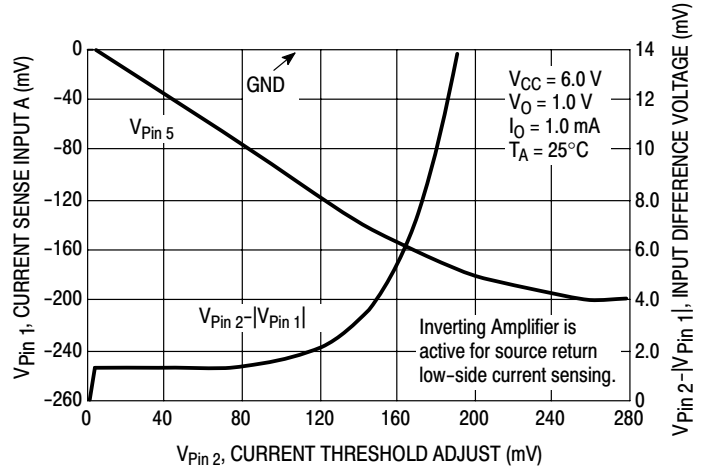

**Figure 7. Closed-Loop Current Sensing Input A versus Current Threshold Adjust**

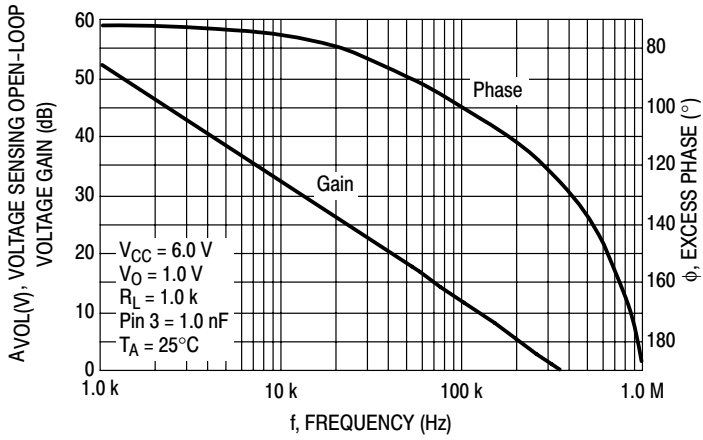

**Figure 8. Bode Plot**  
Voltage Sensing Inputs to Drive Output

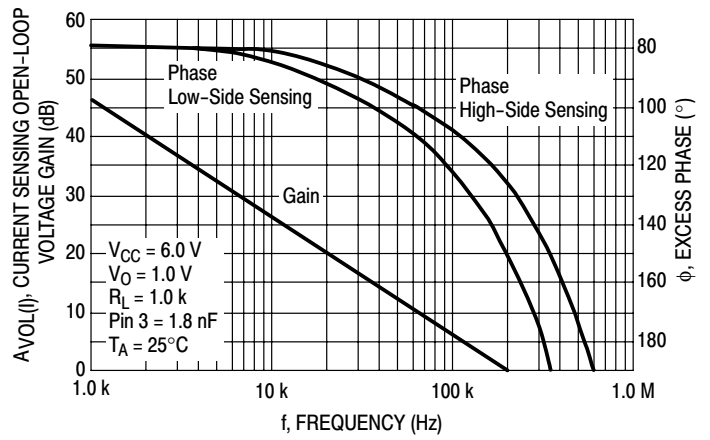

**Figure 9. Bode Plot**  
Current Sensing Inputs to Drive Output

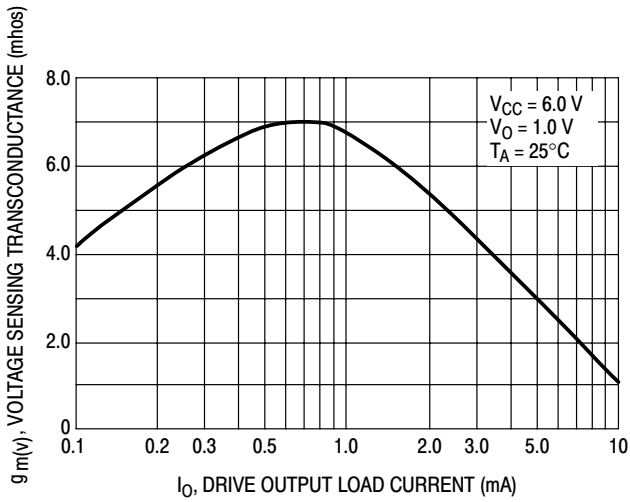

**Figure 10. Transconductance**  
Voltage Sensing Inputs to Drive Output

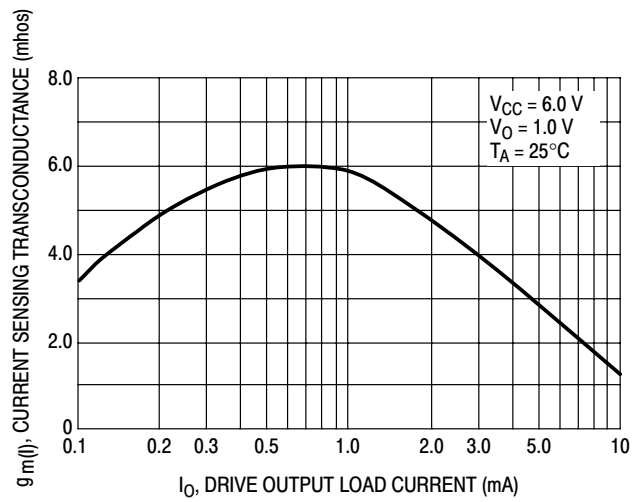

**Figure 11. Transconductance**  
Current Sensing Inputs to Drive Output

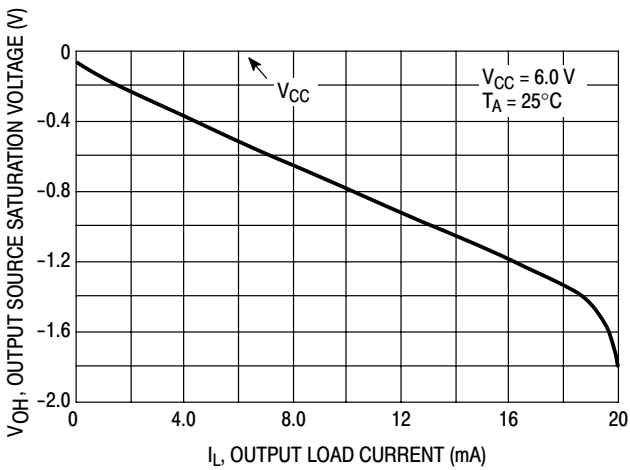

**Figure 12. Drive Output High State**  
Source Saturation versus Load Current

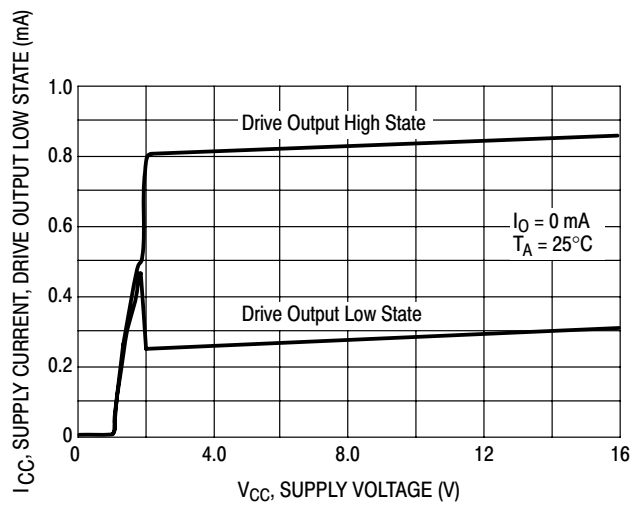

**Figure 13. Supply Current**  
versus Supply Voltage

## INTRODUCTION

Power supplies and battery chargers require precise control of output voltage and current in order to prevent catastrophic damage to the system load. Many present day power sources contain a wide assortment of building blocks and glue devices to perform the required sensing for proper regulation. Typical feedback loop circuits may consist of a voltage and current amplifier, level shifting circuitry, summing circuitry and a reference. The MC33341 contains all of these basic functions in a manner that is easily adaptable to many of the various power source-load configurations.

## OPERATING DESCRIPTION

The MC33341 is an analog regulation control circuit that is specifically designed to simultaneously close the voltage and current feedback loops in power supply and battery charger applications. This device can control the feedback loop in either constant-voltage or constant-current mode with automatic crossover. A concise description of the integrated circuit blocks is given below. Refer to the block diagram in Figure 14.

### Transconductance Amplifier

A quad input transconductance amplifier is used to control the feedback loop. This amplifier has separate voltage and current channels, each with a sense and a threshold input. Within a given channel, if the sense input level exceeds that of the threshold input, the amplifier output is driven high. The channel with the largest difference between the sense and threshold inputs will set the output source current of the amplifier and thus dominate control of the feedback loop. The amplifier output appears at Pin 8 and is a source-only type that is capable of 15 mA.

A high impedance node within the transconductance amplifier is made available at Pin 3 for loop compensation. This pin can sink and source up to 10  $\mu$ A of current. System stability is achieved by connecting a capacitor from Pin 3 to ground. The Compensation Pin signal is out of phase with respect to the Drive Output. By actively clamping Pin 3 low, the Drive Output is forced into a high state. This, in effect, will shutdown the power supply or battery charger, by forcing the output voltage and current regulation threshold down towards zero.

### Voltage Sensing

The voltage that appears across the load is monitored by the noninverting  $V_{\text{sen}}$  input of the transconductance amplifier. This voltage is resistively scaled down and connected to Pin 5. The threshold at which voltage regulation occurs is set by the level present at the inverting  $V_{\text{th}}$  input of the transconductance amplifier. This level is controlled by Pin 6. In source high-side and load high-side current sensing modes, Pin 6 must be connected to the low potential side of current sense resistor  $R_S$ . Under these conditions, the voltage regulation threshold is internally fixed at 1.2 V. In source return low-side and load low-side

current sensing modes, Pin 6 is available, and can be used to lower the regulation threshold of Pin 5. This threshold can be externally adjusted over a range of 0 V to 1.2 V with respect to the IC ground at Pin 4.

### Current Sensing

Current sensing is accomplished by monitoring the voltage that appears across sense resistor  $R_S$ , level shifting it with respect to Pin 4 if required, and applying it to the noninverting  $I_{\text{sen}}$  input of the transconductance amplifier. In order to allow for maximum circuit flexibility, there are three methods of current sensing, each with different internal paths.

In source high-side (Figures 14 and 15) and load high-side (Figures 18 and 19) current sensing, the Differential Amplifier is active with a gain of 1.0. Pin 1 connects to the high potential side of current sense resistor  $R_S$  while Pin 6 connects to the low side. Logic circuitry is provided to disable the Differential Amplifier output whenever low-side current sensing is required. This circuit clamps the Differential Amplifier output high which disconnects it from the  $I_{\text{sen}}$  input of the Transconductance Amplifier. This happens if Pin 1 is less than 1.2 V or if Pin 1 is less than Pin 6.

With source return low-side current sensing (Figures 16 and 17), the Inverting Amplifier is active with a gain of -1.0. Pin 1 connects to the low potential side of current sense resistor  $R_S$  while Pin 4 connects to the high side. Note that a negative voltage appears across  $R_S$  with respect to Pin 4.

In load low-side current sensing (Figures 20 and 21) a Noninverting input path is active with a gain of 1.0. Pin 1 connects to the high potential side of current sense resistor  $R_S$  while Pin 4 connects to the low side. The Noninverting input path lies from Pin 1, through the Inverting Amplifier input and feedback resistors  $R$ , to the cathode of the output diode. With load low-side current sensing, Pin 1 will be more positive than Pin 4, forcing the Inverting Amplifier output low. This causes the diode to be reverse biased, thus preventing the output stage of the amplifier from loading the input signal that is flowing through the feedback resistors.

The regulation threshold in all of the current sensing modes is internally fixed at 200 mV with Pin 2 connected to  $V_{\text{CC}}$ . Pin 2 can be used to externally adjust the threshold over a range of 0 to 200 mV with respect to the IC ground at Pin 4.

### Reference

An internal band gap reference is used to set the 1.2 V voltage threshold and 200 mV current threshold. The reference is initially trimmed to a  $\pm 1.0\%$  tolerance at  $T_A = 25^\circ\text{C}$  and is guaranteed to be within  $\pm 2.0\%$  over an ambient operating temperature range of  $-25^\circ$  to  $85^\circ\text{C}$ .

### Applications

Each of the application circuits illustrate the flexibility of this device. The circuits shown in Figures 14 through 21 contain an optoisolator connected from the Drive Output at

# MC33341

Pin 8 to ground. This configuration is shown for ease of understanding and would normally be used to provide an isolated control signal to a primary side switching regulator controller. In non-isolated, primary or secondary side applications, a load resistor can be placed from Pin 8 to ground. This resistor will convert the Drive Output current to a voltage for direct control of a regulator.

In applications where excessively high peak currents are possible from the source or load, the load induced voltage

drop across  $R_S$  could exceed 1.6 V. Depending upon the current sensing configuration used, this will result in forward biasing of either the internal  $V_{CC}$  clamp diode, Pin 6, or the device substrate, Pin 1. Under these conditions, input series resistor  $R_3$  is required. The peak input current should be limited to 20 mA. Excessively large values for  $R_3$  will degrade the current sensing accuracy. Figure 22 shows a method of bounding the voltage drop across  $R_S$  without sacrificing current sensing accuracy.

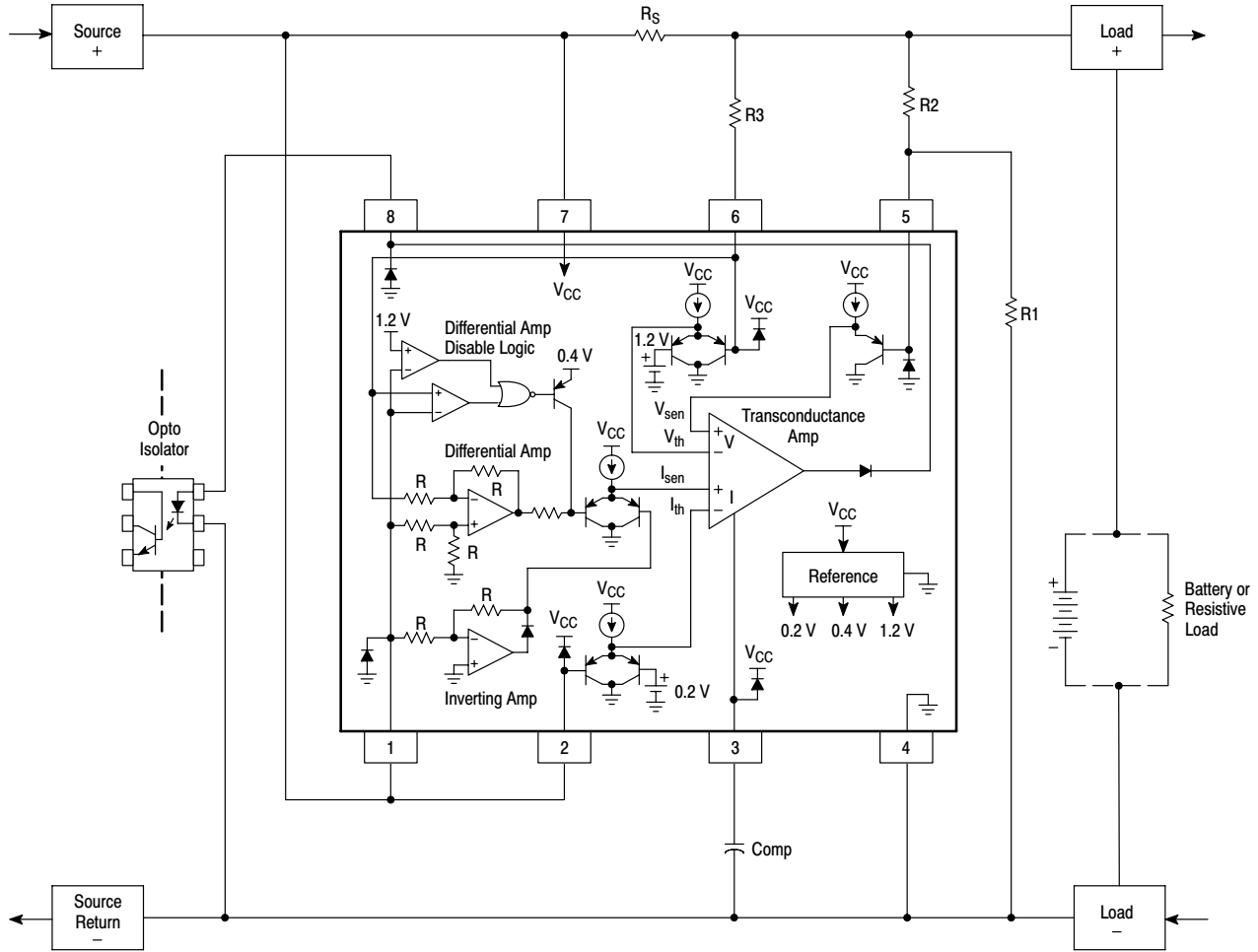

The above figure shows the MC33341 configured for source high-side current sensing allowing a common ground path between Load - and Source Return -. The Differential Amplifier inputs, Pins 1 and 6, are used to sense the load induced voltage drop that appears across resistor  $R_S$ . The internal voltage and current regulation thresholds are selected by the respective external connections of Pins 2 and 6. Resistor  $R_3$  is required in applications where a high peak level of reverse current is possible if the source inputs are shorted. The resistor value should be chosen to limit the input current of the internal  $V_{CC}$  clamp diode to less than 20 mA. Excessively large values for  $R_3$  will degrade the current sensing accuracy.

$$V_{reg} = V_{th(V)} \left( \frac{R_2}{R_1} + 1 \right) = 1.2 \left( \frac{R_2}{R_1} + 1 \right)$$

$$I_{reg} = \frac{V_{th(I HS)}}{R_S} = \frac{0.2}{R_S}$$

$$R_3 = \frac{\left( I_{pk} R_S \right) - 0.6}{0.02}$$

**Figure 14. Source High-Side Current Sensing with Internally Fixed Voltage and Current Thresholds**

# MC33341

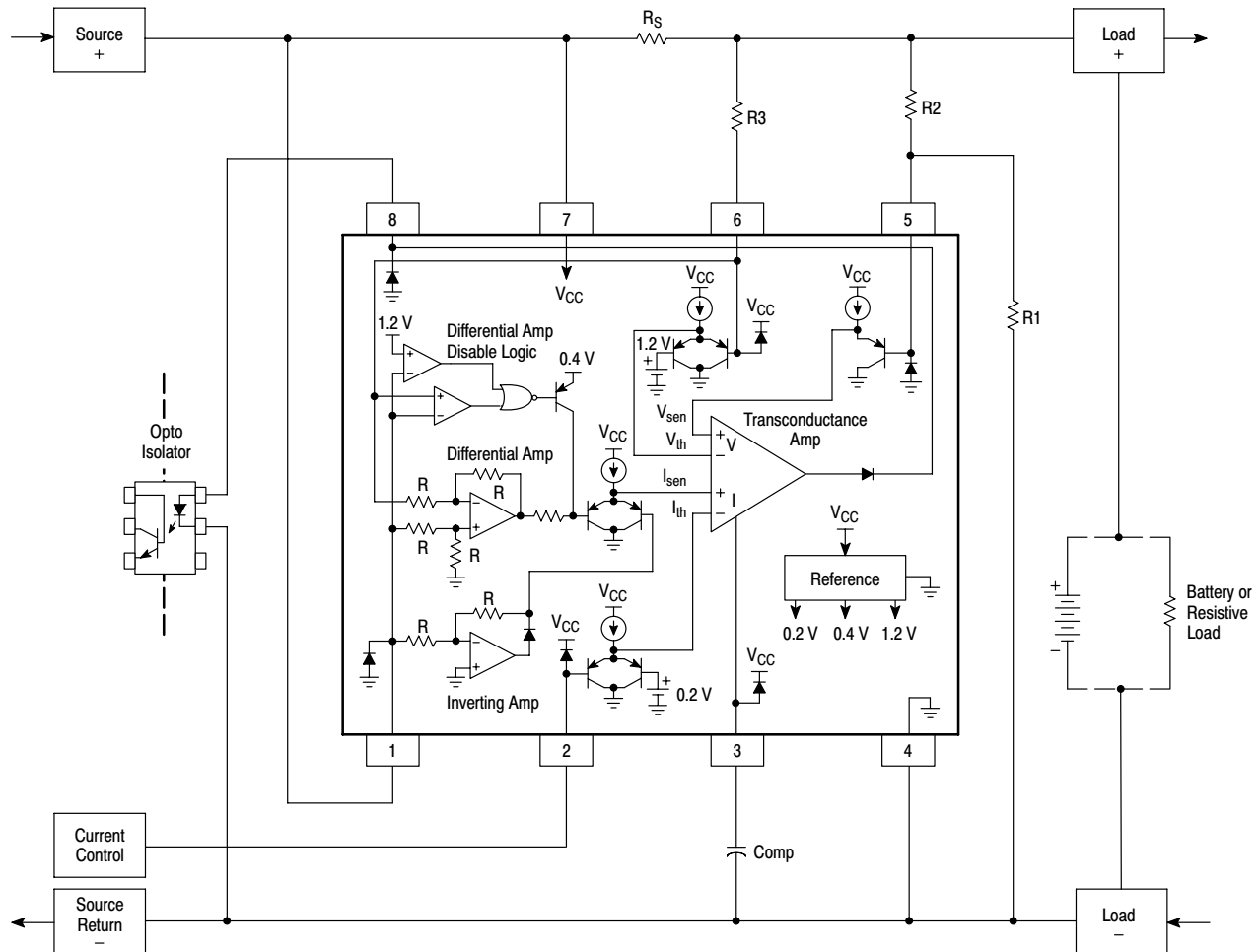

The above figure shows the MC33341 configured for source high-side current sensing with an externally adjustable current threshold. Operation of this circuit is similar to that of Figure 14. The current regulation threshold can be adjusted over a range of 0 V to 200 mV with respect to Pin 4.

$$V_{reg} = V_{th(V)} \left( \frac{R2}{R1} + 1 \right)$$

$$I_{reg} = \frac{V_{th(Pin 2)}}{R_S}$$

$$R3 = \frac{(I_{pk} R_S) - 0.6}{0.02}$$

$$= 1.2 \left( \frac{R2}{R1} + 1 \right)$$

**Figure 15. Source High-Side Current Sensing with Externally Adjustable Current and Internally Fixed Voltage Thresholds**

# MC33341

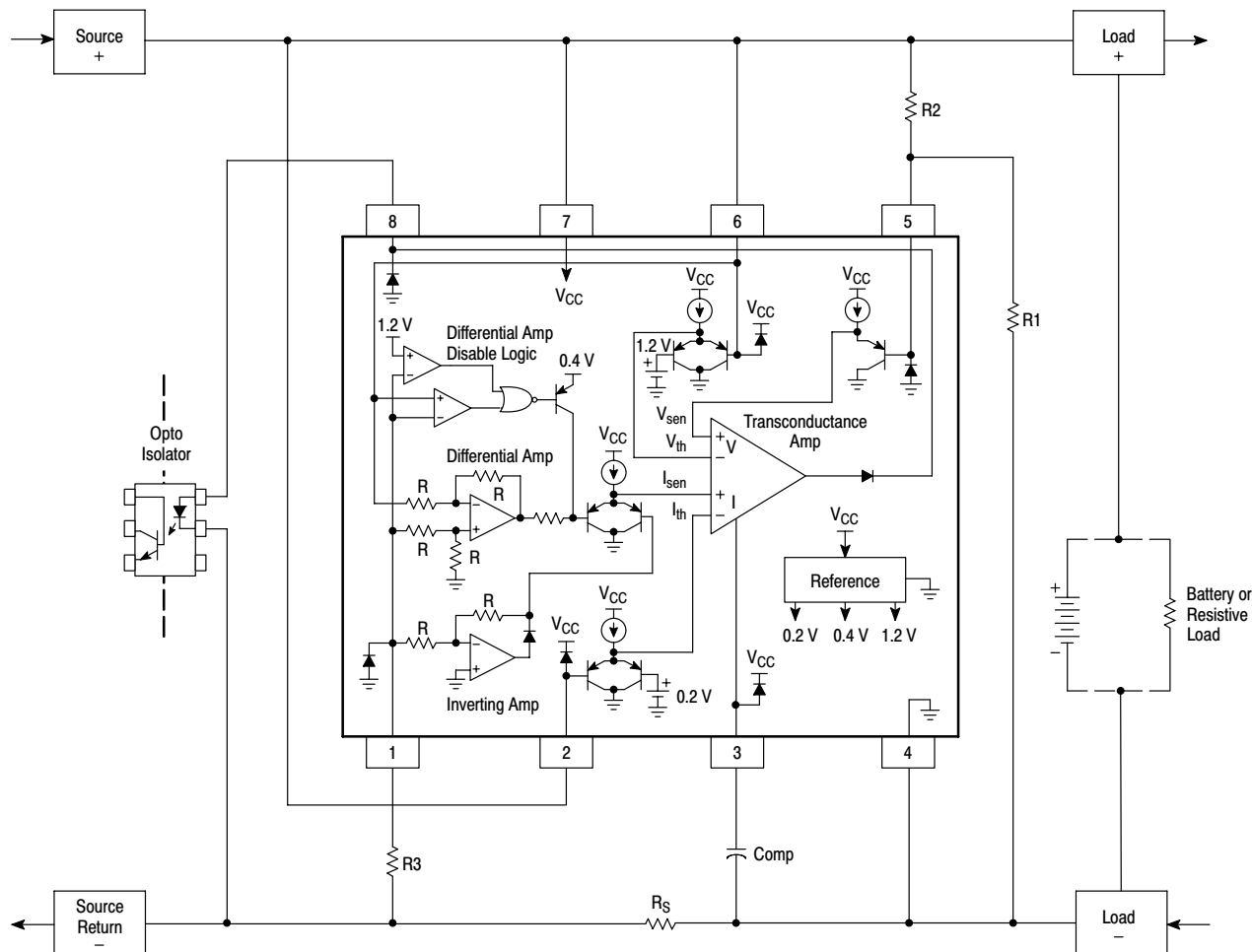

The above figure shows the MC33341 configured for source return low-side current sensing allowing a common power path between Source + and Load +. This configuration is especially suited for negative output applications where a common ground path, Source + to Load +, is desired. The Inverting Amplifier inputs, Pins 1 and 4, are used to sense the load induced voltage drop that appears across resistor  $R_S$ . The internal voltage and current regulation thresholds are selected by the respective external connections of Pins 2 and 6. Resistor  $R_3$  is required in applications where high peak levels of inrush current are possible. The resistor value should be chosen to limit the negative substrate current to less than 20 mA. Excessively large values for  $R_3$  will degrade the current sensing accuracy.

$$V_{reg} = V_{th(V)} \left( \frac{R_2}{R_1} + 1 \right)$$

$$I_{reg} = \frac{V_{th(I_{LS-})}}{R_S}$$

$$R_3 = \frac{(I_{pk} R_S) - 0.6}{0.02}$$

$$= 1.2 \left( \frac{R_2}{R_1} + 1 \right)$$

$$= \frac{-0.2}{R_S}$$

**Figure 16. Source Return Low-Side Current Sensing with Internally Fixed Current and Voltage Thresholds**

# MC33341

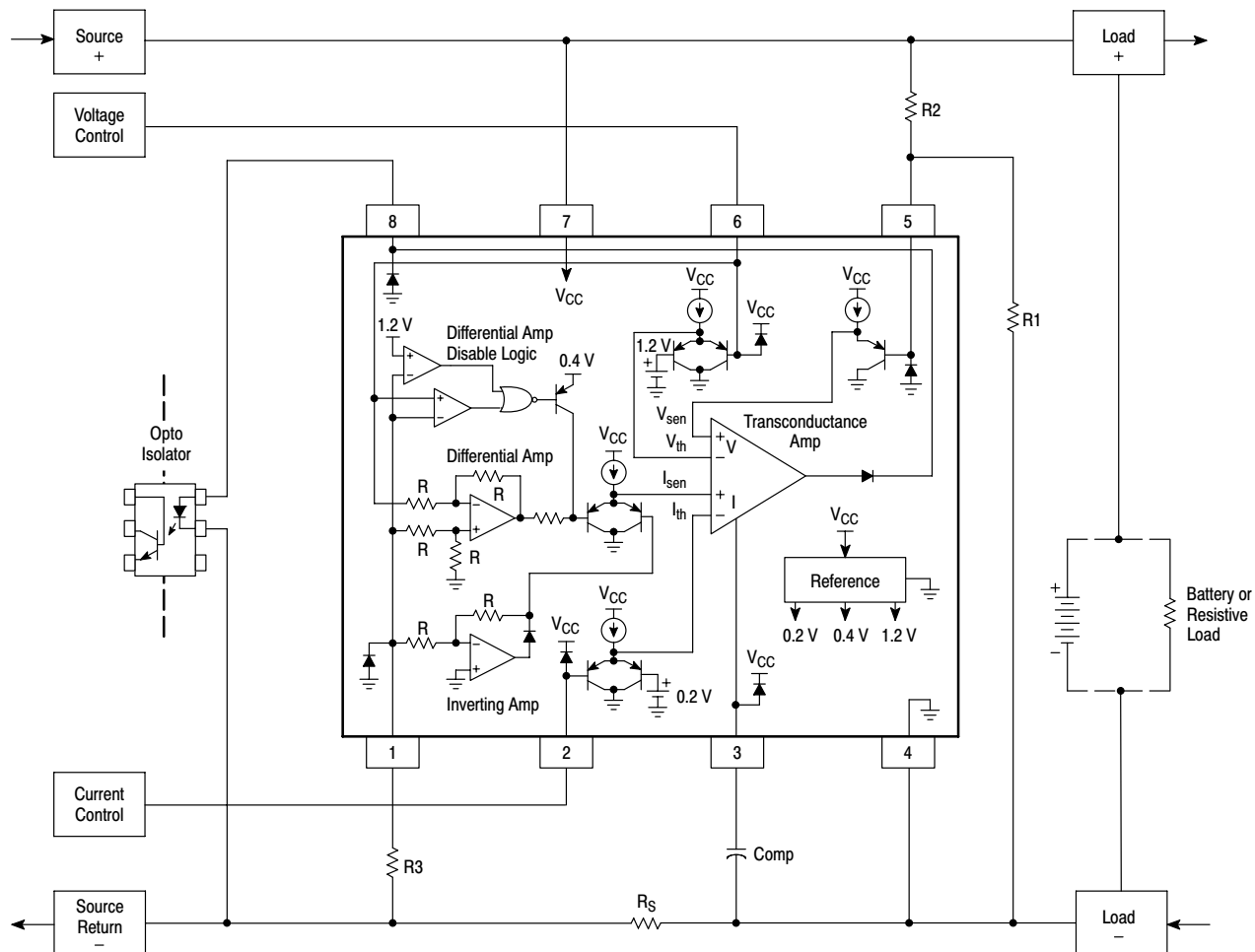

The above figure shows the MC33341 configured for source return low-side current sensing with externally adjustable voltage and current thresholds. Operation of this circuit is similar to that of Figure 16. The respective voltage and current regulation threshold can be adjusted over a range of 0 to 1.6 V and 0 V to 200 mV with respect to Pin 4.

$$V_{\text{reg}} = V_{\text{th(Pin 6)}} \left( \frac{R2}{R1} + 1 \right) \quad I_{\text{reg}} = - \frac{V_{\text{th(Pin 2)}}}{R_S} \quad R3 = \frac{(I_{\text{pk}} R_S) - 0.6}{0.02}$$

**Figure 17. Source Return Low-Side Current Sensing with Externally Adjustable Current and Voltage Thresholds**

# MC33341

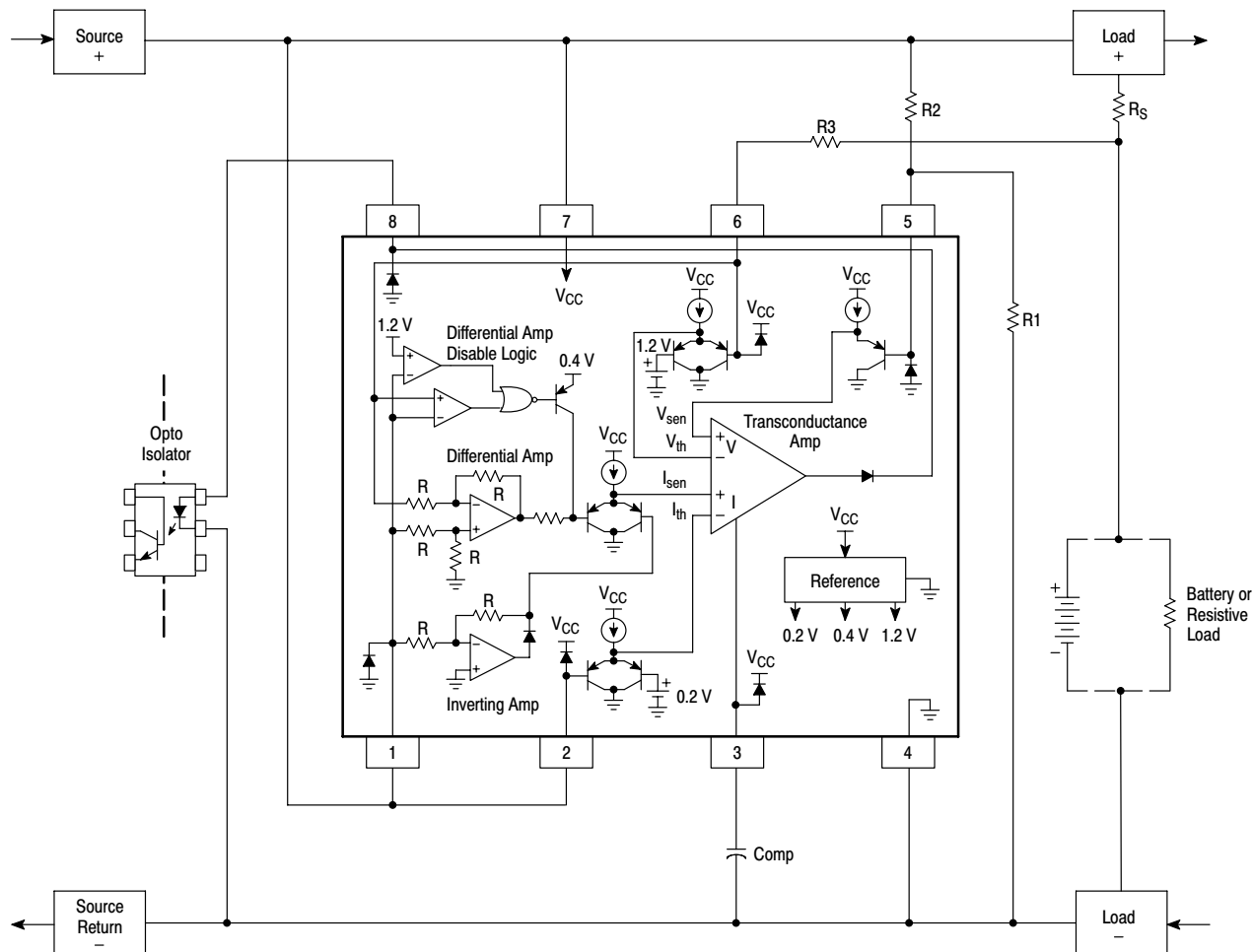

The above figure shows the MC33341 configured for load high-side current sensing allowing common paths for both power and ground, between the source and load. The Differential Amplifier inputs, Pins 1 and 6, are used to sense the load induced voltage drop that appears across resistor  $R_S$ . The internal voltage and current regulation thresholds are selected by the respective external connections of Pins 2 and 6. Resistor R3 is required in applications where high peak levels of load current are possible from the battery or load bypass capacitor. The resistor value should be chosen to limit the input current of the internal  $V_{CC}$  clamp diode to less than 20 mA. Excessively large values for R3 will degrade the current sensing accuracy.

$$\begin{aligned}
 V_{reg} &= V_{th(V)} \left( \frac{R_2}{R_1} + 1 \right) \\
 &= 1.2 \left( \frac{R_2}{R_1} + 1 \right) \\
 I_{reg} &= \frac{V_{th(I HS)}}{R_S} \\
 &= \frac{0.2}{R_S} \\
 R_3 &= \frac{(I_{pk} R_S) - 0.6}{0.02}
 \end{aligned}$$

**Figure 18. Load High-Side Current Sensing with Internally Fixed Current and Voltage Thresholds**

# MC33341

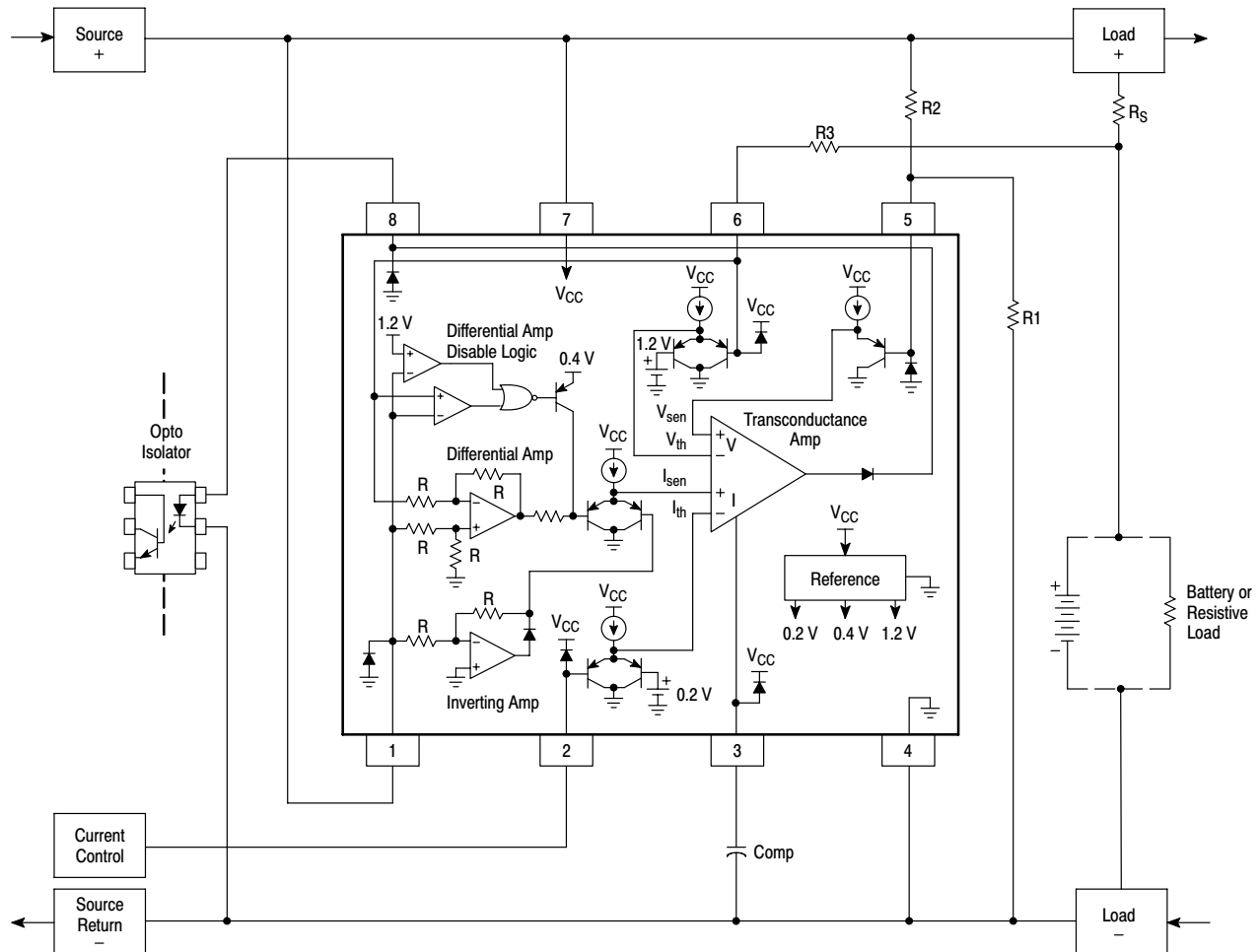

The above figure shows the MC33341 configured for load high-side current sensing with an externally adjustable current threshold. Operation of this circuit is similar to that of Figure 18. The current regulation threshold can be adjusted over a range of 0 V to 200 mV with respect to Pin 4.

$$V_{reg} = V_{th(V)} \left( \frac{R_2}{R_1} + 1 \right)$$

$$I_{reg} = \frac{V_{th(\text{Pin } 2)}}{R_S}$$

$$R_3 = \frac{(I_{pk} R_S) - 0.6}{0.02}$$

$$= 1.2 \left( \frac{R_2}{R_1} + 1 \right)$$

**Figure 19. Load High-Side Current Sensing with Externally Adjustable Current and Internally Fixed Voltage Thresholds**

# MC33341

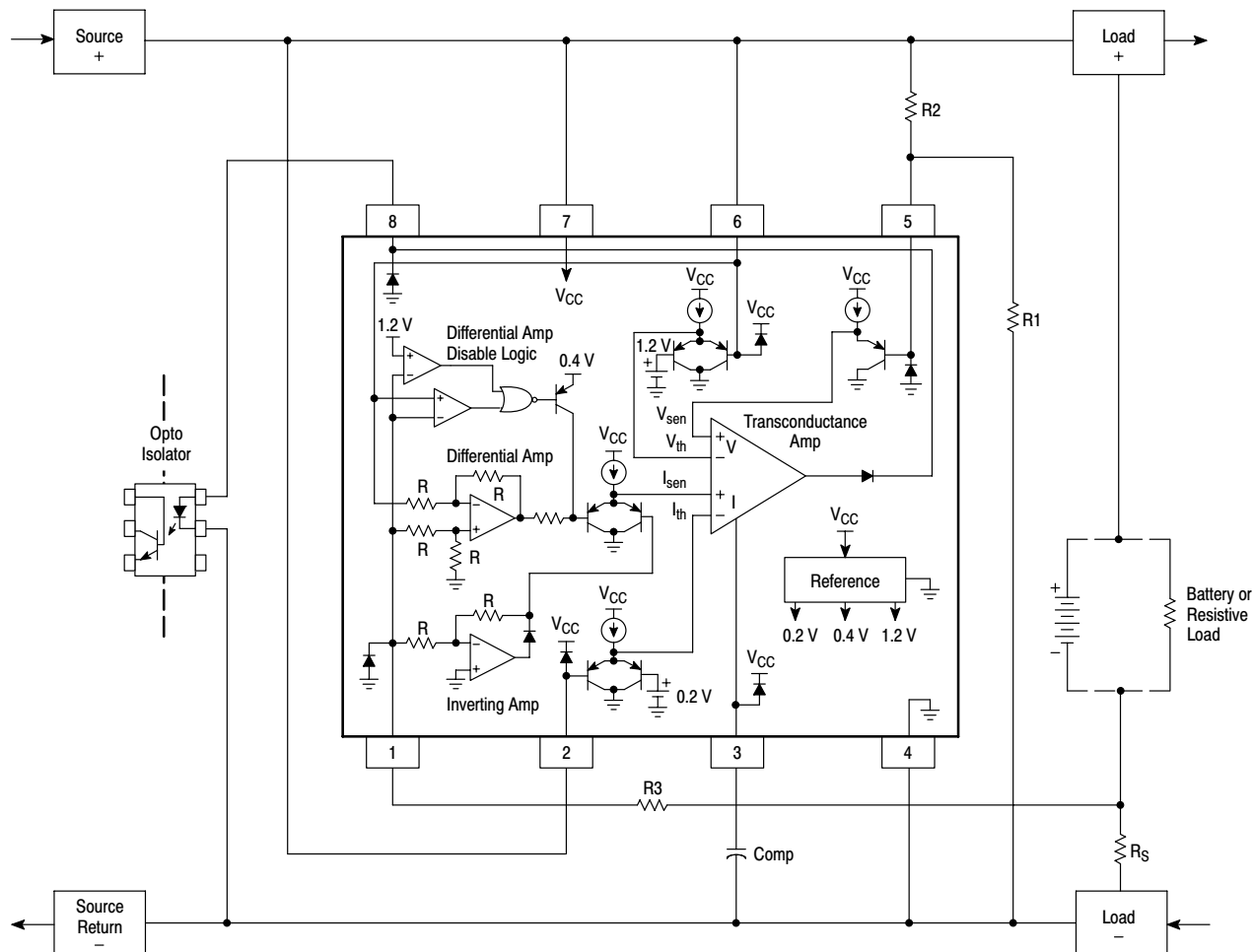

The above figure shows the MC33341 configured for load low-side current sensing allowing common paths for both power and ground, between the source and load. The Noninverting input paths, Pins 1 and 4, are used to sense the load induced voltage drop that appears across resistor  $R_S$ . The internal voltage and current regulation thresholds are selected by the respective external connections of Pins 2 and 6. Resistor  $R_3$  is required in applications where high peak levels of load current are possible from the battery or load bypass capacitor. The resistor value should be chosen to limit the negative substrate current to less than 20 mA. Excessively large values for  $R_3$  will degrade the current sensing accuracy.

$$V_{reg} = V_{th(V)} \left( \frac{R_2}{R_1} + 1 \right)$$

$$= 1.2 \left( \frac{R_2}{R_1} + 1 \right)$$

$$I_{reg} = \frac{V_{th(I LS+)} }{R_S}$$

$$= \frac{0.2}{R_S}$$

$$R_3 = \frac{(I_{pk} R_S) - 0.6}{0.02}$$

**Figure 20. Load Low-Side Current Sensing with Internally Fixed Current and Voltage Thresholds**

# MC33341

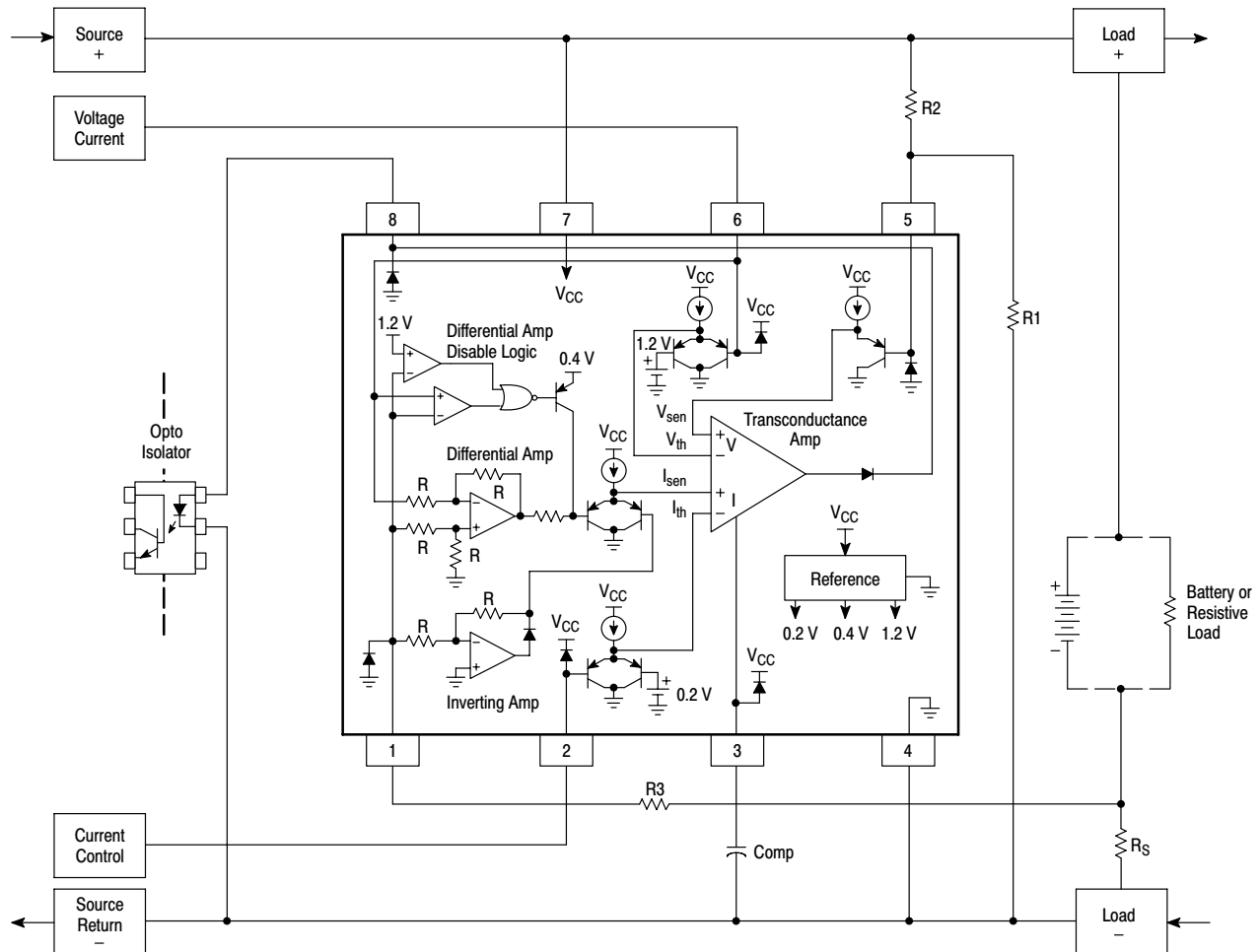

The above figure shows the MC33341 configured for load low-side current sensing with an externally adjustable voltage and current threshold. Operation of this circuit is similar to that of Figure 20. The respective voltage and current regulation threshold can be adjusted over a range of 0 to 1.2 V and 0 V to 200 mV, with respect to Pin 4.

$$V_{\text{reg}} = V_{\text{th(Pin 6)}} \left( \frac{R_2}{R_1} + 1 \right) \quad I_{\text{reg}} = \frac{V_{\text{th(Pin 2)}}}{R_S} \quad R_3 = \frac{(I_{\text{pk}} R_S) - 0.6}{0.02}$$

**Figure 21. Load Low-Side Current Sensing with Externally Adjustable Current and Voltage Thresholds**

## MC33341

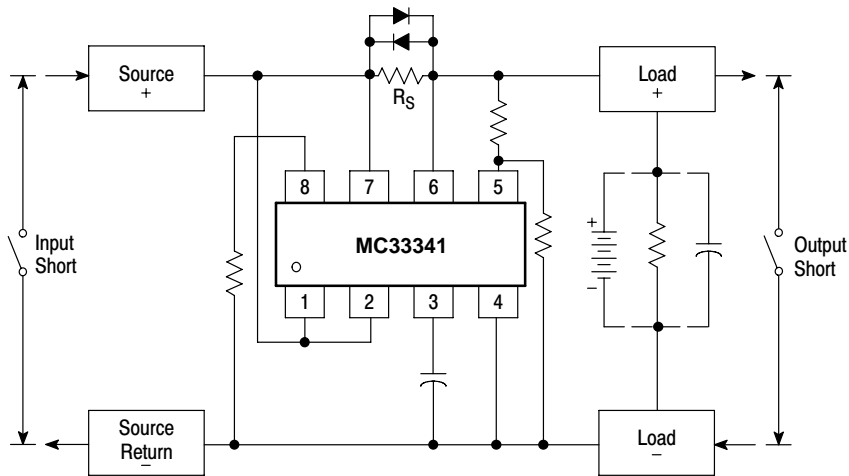

NOTE: An excessive load induced voltage across  $R_S$  can occur if either the source input or load output is shorted. This voltage can easily be bounded with the addition of the diodes shown without degrading the current sensing accuracy. This bounding technique can be used in any of the MC33341 applications where high peak currents are anticipated.

**Figure 22. Current Sense Resistor Bounding**

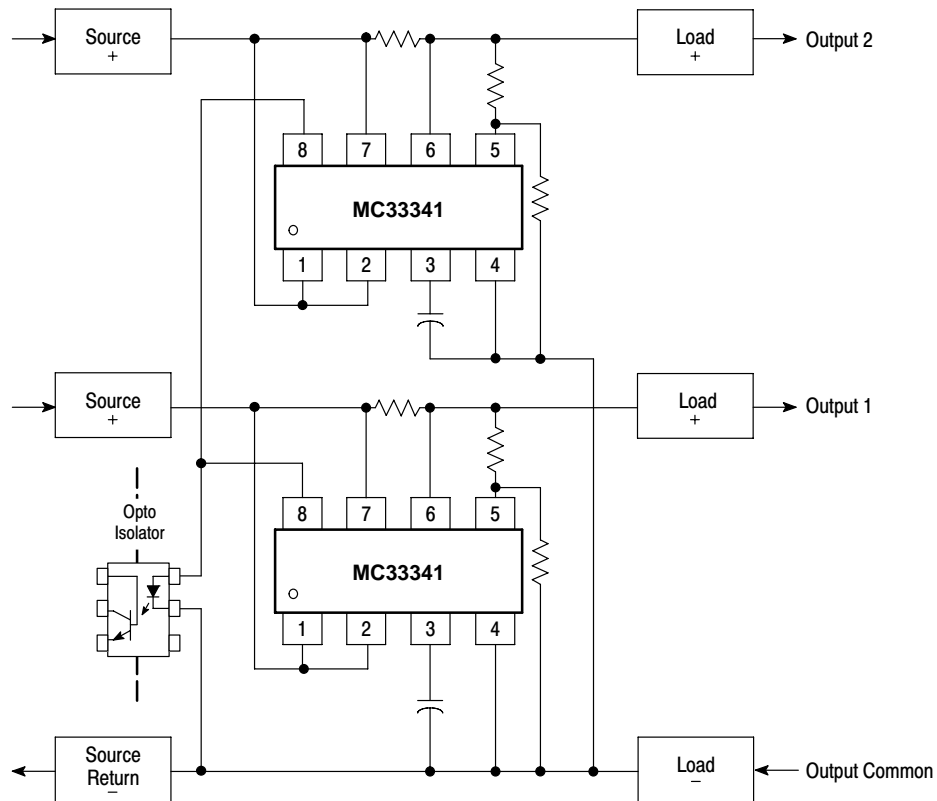

NOTE: Multiple outputs can be controlled by summing the error signal into a common optoisolator. The converter output with the largest voltage or current error will dominate control of the feedback loop.

**Figure 23. Multiple Output Current and Voltage Regulation**

# MC33341

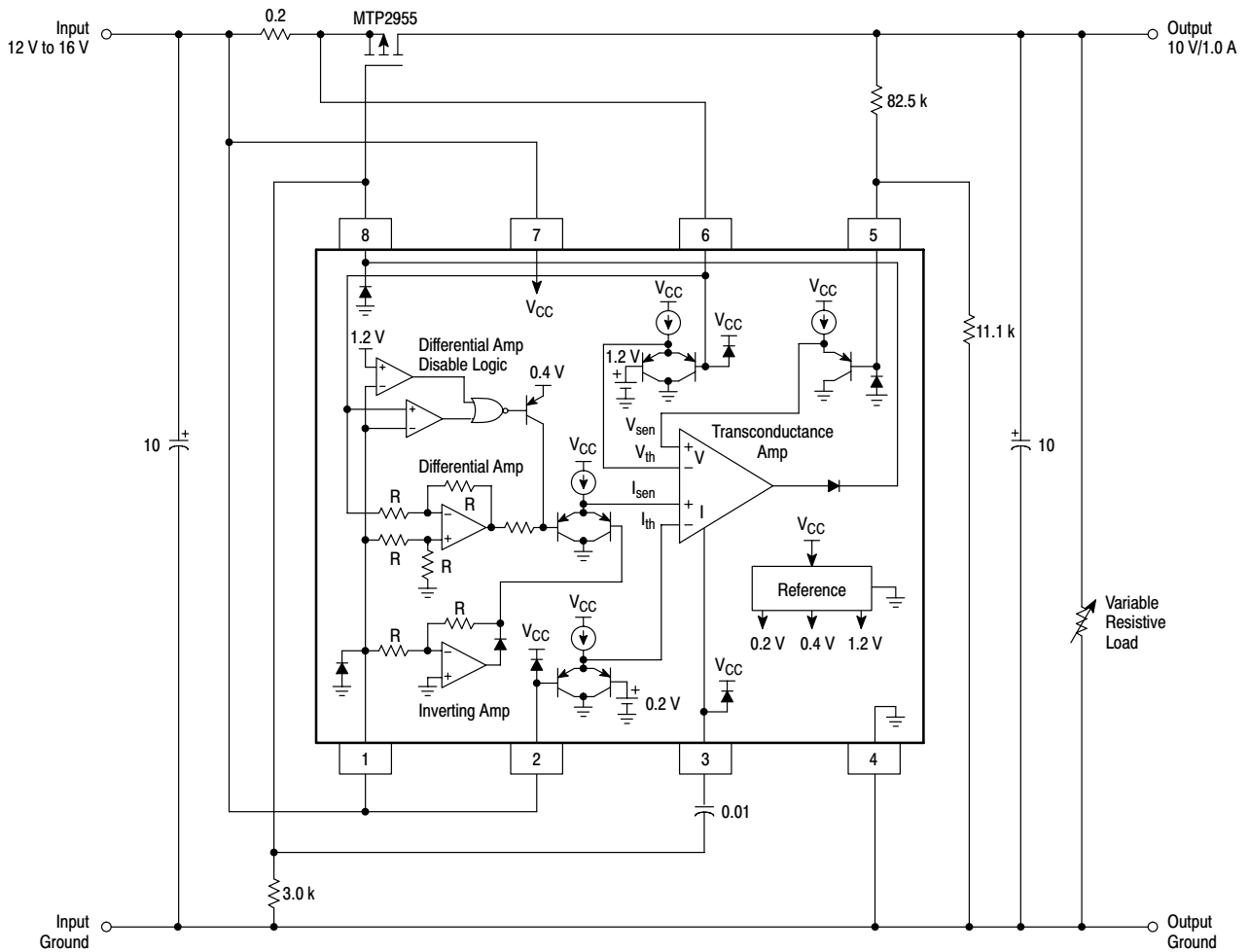

Figure 24. 10 V/1.0 A Constant-Voltage Constant-Current Regulator

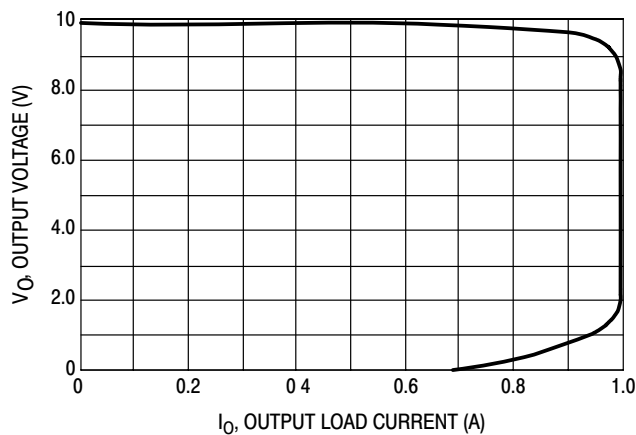

Figure 24 shows the MC33341 configured as a source high-side constant-voltage constant-current regulator. The regulator is designed for an output voltage of 10 V at 1.0 A. Figure 25 shows the regulator's output characteristics as the load is varied. Source return low-side, load high-side, and load low-side configurations will each exhibit a nearly identical load regulation characteristic. A heatsink is required for the MTP2955 series pass element.

Figure 25. Output Load Regulation

# MC33341

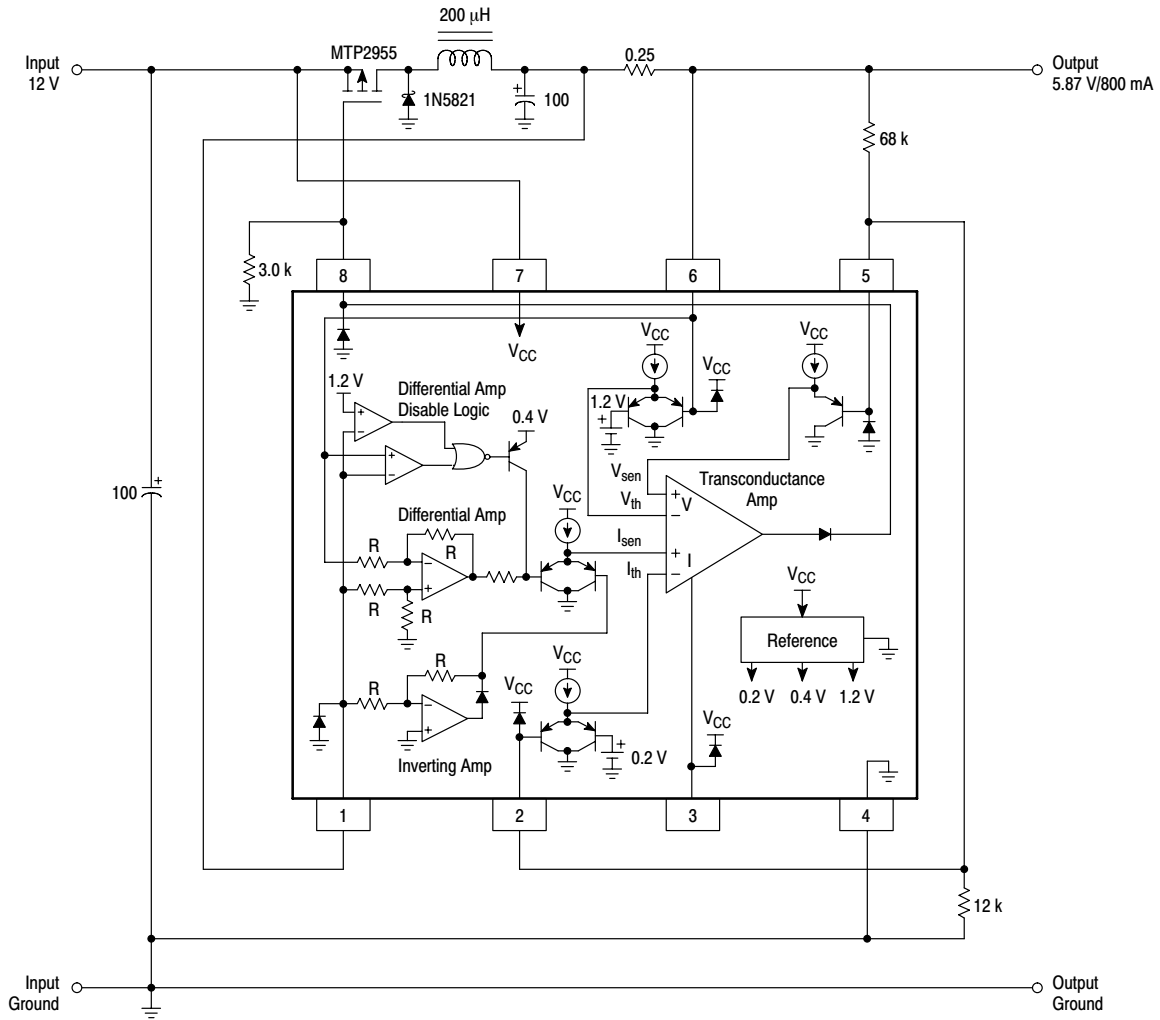

Figure 26 shows that the MC33341 can be configured as a high-side constant-current constant-voltage switch mode charger. This circuit operates as a step down converter. With a nominal input voltage and output load current as stated above, the switching frequency is approximately 28 kHz with an associated conversion efficiency of 86 percent. The switching frequency will vary with changes in input voltage and load current.

**Figure 26. Constant-Current Constant-Voltage Switch Mode Charger**

## ORDERING INFORMATION

Device	Operating Temperature Range	Package	Shipping†
MC33341D	$T_A = -25^\circ \text{ to } +85^\circ \text{C}$	SOIC-8	98 Units / Rail
MC33341DG		SOIC-8 (Pb-Free)	98 Units / Rail
MC33341DR2		SOIC-8	2500 / Tape & Reel
MC33341DR2G		SOIC-8 (Pb-Free)	2500 / Tape & Reel
MC33341P		PDIP-8	50 Units / Rail
MC33341PG		PDIP-8 (Pb-Free)	50 Units / Rail

†For information on tape and reel specifications, including part orientation and tape sizes, please refer to our Tape and Reel Packaging Specifications Brochure, BRD8011/D.

# MC33341

## PACKAGE DIMENSIONS

SOIC-8 NB  
D SUFFIX  
PLASTIC PACKAGE  
CASE 751-07  
ISSUE AH

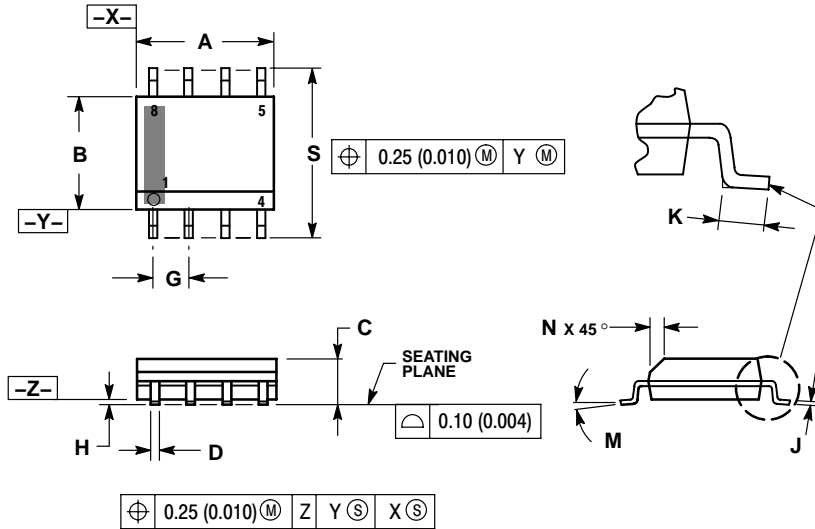

**NOTES:**

1. DIMENSIONING AND TOLERANCING PER ANSI Y14.5M, 1982.
2. CONTROLLING DIMENSION: MILLIMETER.
3. DIMENSION A AND B DO NOT INCLUDE MOLD PROTRUSION.
4. MAXIMUM MOLD PROTRUSION 0.15 (0.006) PER SIDE.
5. DIMENSION D DOES NOT INCLUDE DAMBAR PROTRUSION. ALLOWABLE DAMBAR PROTRUSION SHALL BE 0.127 (0.005) TOTAL IN EXCESS OF THE D DIMENSION AT MAXIMUM MATERIAL CONDITION.
6. 751-01 THRU 751-06 ARE OBSOLETE. NEW STANDARD IS 751-07.

DIM	MILLIMETERS		INCHES	
	MIN	MAX	MIN	MAX
A	4.80	5.00	0.189	0.197
B	3.80	4.00	0.150	0.157
C	1.35	1.75	0.053	0.069
D	0.33	0.51	0.013	0.020
G	1.27 BSC		0.050 BSC	
H	0.10	0.25	0.004	0.010
J	0.19	0.25	0.007	0.010
K	0.40	1.27	0.016	0.050
M	0°	8°	0°	8°
N	0.25	0.50	0.010	0.020
S	5.80	6.20	0.228	0.244

### SOLDERING FOOTPRINT\*

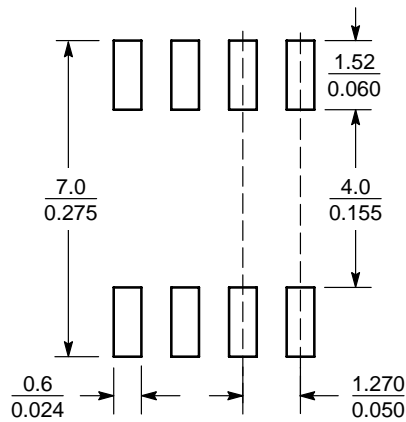

SCALE 6:1 (mm/inches)

\*For additional information on our Pb-Free strategy and soldering details, please download the ON Semiconductor Soldering and Mounting Techniques Reference Manual, SOLDERRM/D.

# MC33341

## PACKAGE DIMENSIONS

PDIP-8  
P SUFFIX  
PLASTIC PACKAGE  
CASE 626-05  
ISSUE L

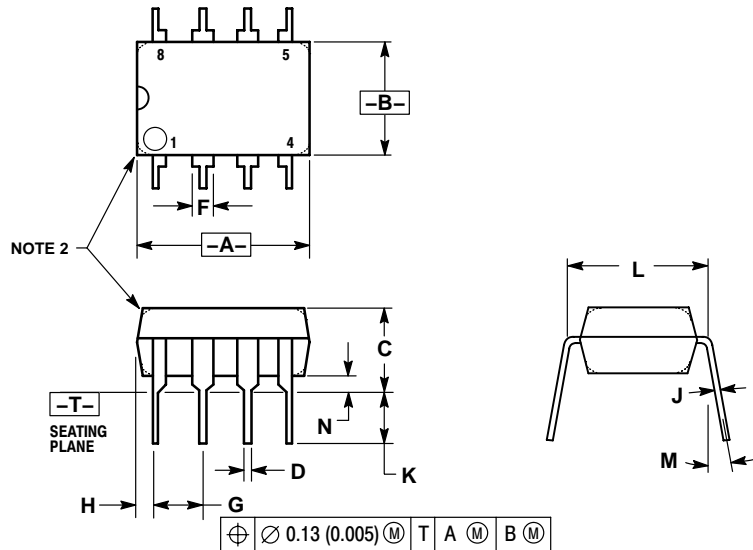

- NOTES:
1. DIMENSION L TO CENTER OF LEAD WHEN FORMED PARALLEL.
  2. PACKAGE CONTOUR OPTIONAL (ROUND OR SQUARE CORNERS).
  3. DIMENSIONING AND TOLERANCING PER ANSI Y14.5M, 1982.

DIM	MILLIMETERS		INCHES	
	MIN	MAX	MIN	MAX
A	9.40	10.16	0.370	0.400
B	6.10	6.60	0.240	0.260
C	3.94	4.45	0.155	0.175
D	0.38	0.51	0.015	0.020
F	1.02	1.78	0.040	0.070
G	2.54 BSC		0.100 BSC	
H	0.76	1.27	0.030	0.050
J	0.20	0.30	0.008	0.012
K	2.92	3.43	0.115	0.135
L	7.62 BSC		0.300 BSC	
M	---	10°	---	10°
N	0.76	1.01	0.030	0.040

ON Semiconductor and are registered trademarks of Semiconductor Components Industries, LLC (SCILLC). SCILLC reserves the right to make changes without further notice to any products herein. SCILLC makes no warranty, representation or guarantee regarding the suitability of its products for any particular purpose, nor does SCILLC assume any liability arising out of the application or use of any product or circuit, and specifically disclaims any and all liability, including without limitation special, consequential or incidental damages. "Typical" parameters which may be provided in SCILLC data sheets and/or specifications can and do vary in different applications and actual performance may vary over time. All operating parameters, including "Typicals" must be validated for each customer application by customer's technical experts. SCILLC does not convey any license under its patent rights nor the rights of others. SCILLC products are not designed, intended, or authorized for use as components in systems intended for surgical implant into the body, or other applications intended to support or sustain life, or for any other application in which the failure of the SCILLC product could create a situation where personal injury or death may occur. Should Buyer purchase or use SCILLC products for any such unintended or unauthorized application, Buyer shall indemnify and hold SCILLC and its officers, employees, subsidiaries, affiliates, and distributors harmless against all claims, costs, damages, and expenses, and reasonable attorney fees arising out of, directly or indirectly, any claim of personal injury or death associated with such unintended or unauthorized use, even if such claim alleges that SCILLC was negligent regarding the design or manufacture of the part. SCILLC is an Equal Opportunity/Affirmative Action Employer. This literature is subject to all applicable copyright laws and is not for resale in any manner.

### PUBLICATION ORDERING INFORMATION

**LITERATURE FULFILLMENT:**  
Literature Distribution Center for ON Semiconductor  
P.O. Box 5163, Denver, Colorado 80217 USA  
**Phone:** 303-675-2175 or 800-344-3860 Toll Free USA/Canada  
**Fax:** 303-675-2176 or 800-344-3867 Toll Free USA/Canada  
**Email:** orderlit@onsemi.com

**N. American Technical Support:** 800-282-9855 Toll Free USA/Canada  
**Europe, Middle East and Africa Technical Support:**  
Phone: 421 33 790 2910  
**Japan Customer Focus Center**  
Phone: 81-3-5773-3850

**ON Semiconductor Website:** [www.onsemi.com](http://www.onsemi.com)  
**Order Literature:** <http://www.onsemi.com/orderlit>  
For additional information, please contact your local Sales Representative

## Looking for pricing, stock, or lifecycle information?

Click below to explore more details on WIN SOURCE:

 [View MC33341DG on WIN SOURCE](#)

 [ON Semiconductor](#) Information

## Optimize Your Supply Chain with WIN SOURCE Solutions

-  Global Sourcing Solution
-  Obsolete Management
-  Cost Control Management
-  Shortage Management
-  Alternative Solution
-  Excess Inventory Management