



**THE DATASHEET OF  
FTLF1321S1MTL**



## Product Specification

### OC-48 SR-1/STM S-16 Multirate 2x10 SFF Transceiver

### FTLF1321S1xTL

#### PRODUCT FEATURES

- Up to 2.67Gb/s bi-directional data links
- Standard 2x10 pin SFF footprint (MSA compliant)
- Analog diagnostics functions
- Uncooled 1310nm FP laser transmitter
- Duplex LC connector
- Very low jitter
- Metal enclosure, for lower EMI
- Single 3.3V power supply
- Low power dissipation <700 mW typical
- Extended operating temperature range: -40°C to 85°C



#### APPLICATIONS

- SONET OC-48 SR-1 / SDH STM I-16.1
- SONET OC-12 SR-1 / SDH STM I-4.1
- SONET OC-3 SR-1/ SDH STM I-1.1
- Gigabit Ethernet / 1x/2x Fibre Channel

Finisar's FTLF1321S1xTL Small Form Factor (SFF) transceivers are compatible with the Small Form Factor Multi-Sourcing Agreement (MSA)<sup>1</sup>. They comply with SONET OC-48 SR-1 (SDH STM S-16) standards<sup>2</sup>, and are compatible with Gigabit Ethernet as specified in IEEE Std 802.3<sup>3</sup>, Fibre Channel FC-PI 13.0<sup>4</sup>, SONET OC-12 and SONET OC-3 standards<sup>2</sup>. The transceivers are RoHS compliant and lead-free per Directive 2002/95/EC<sup>5</sup> and Finisar Application Note AN-2038<sup>6</sup>

#### PRODUCT SELECTION

### FTLF1321S1xTL

x	G	2 Grounding Pins, Short EMI shield
	M	6 Grounding Pins, Short EMI shield
	K	2 Grounding Pins, Long EMI shield
	H	6 Grounding Pins, Long EMI shield

## I. Pin Descriptions

Pin	Symbol	Name/Description	Logic Family
MS	MS	Mounting Studs for mechanical attachment. <b>Chassis ground is internally isolated from circuit ground.</b> Connection to chassis ground is recommended.	NA
1	PD	Receiver Power Monitor. This pin must be connected to a positive voltage supply (Vcc), preferably via a small resistor. Supplies photocurrent and may be used to monitor received power.	Analog Current
2,3,6	V <sub>EER</sub>	Receiver Ground (Common with Transmitter Ground)	NA
4,5	NC	Not Connected.	
7	V <sub>CCR</sub>	Receiver Power Supply	NA
8	SD	Signal Detect. Logic 1 indicates normal operation.	LVTTTL
9	RD-	Receiver Inverted DATA out. AC Coupled	CML
10	RD+	Receiver Non-inverted DATA out. AC Coupled	CML
11	V <sub>CCT</sub>	Transmitter Power Supply	NA
12,16	V <sub>EET</sub>	Transmitter Ground (Common with Receiver Ground)	NA
13	T <sub>DIS</sub>	Transmitter Disable	LVTTTL
14	TD+	Transmitter Non-Inverted DATA in. AC Coupled.	CML ECL
15	TD-	Transmitter Inverted DATA in. AC Coupled.	CML ECL
17	Bmon-	Laser Bias Monitoring (-).	Analog Voltage
18	Bmon+	Laser Bias Monitoring (+) (Bmon+ - Bmon-) = 10Ω x laser bias current.	Analog Voltage
19	Pmon-	Laser Power Monitoring (-). Current implementation connects this pin to ground	Analog Voltage
20	Pmon+	Laser Power Monitoring (+) (Pmon+ - Pmon-) = 200Ω x mon. photodiode current.	Analog Voltage

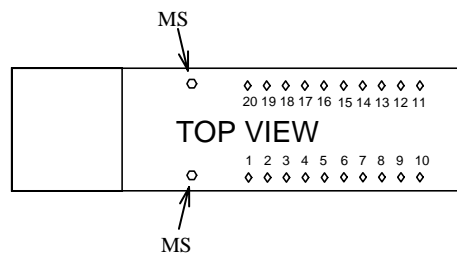

## II. Absolute Maximum Ratings

Parameter	Symbol	Min	Typ	Max	Unit	Ref.
Maximum Supply Voltage	V <sub>CC</sub>	-0.5		4.5	V	
Storage Temperature	T <sub>S</sub>	-40		100	°C	
Case Operating Temperature	T <sub>OP</sub>	-40		85	°C	
Relative Humidity	RH	0		85	%	1
Lead Soldering Temperature/Time				260/10	°C/s	

## III. Electrical Characteristics (T<sub>OP</sub> = -40 to 85 °C, V<sub>CC</sub> = 3.00 to 3.60 Volts)

Parameter	Symbol	Min	Typ	Max	Unit	Ref.
Supply Voltage	V <sub>CC</sub>	3.00		3.60	V	
Supply Current	I <sub>CC</sub>		190	300	mA	
<b>Transmitter</b>						
Input differential impedance	R <sub>in</sub>		100		Ω	2
Single ended data input swing	V <sub>in,pp</sub>	250		1200	mV	
Transmit Disable Voltage	V <sub>D</sub>	V <sub>CC</sub> – 1.3		V <sub>CC</sub>	V	
Transmit Enable Voltage	V <sub>EN</sub>	V <sub>EE</sub>		V <sub>EE</sub> + 0.8	V	3
Transmit Disable Assert Time				10	μs	
<b>Receiver</b>						
Single ended data output swing	V <sub>out,pp</sub>	300	400	800	mV	4
Data output rise time	t <sub>r</sub>		100	175	ps	5
Data output fall time	t <sub>f</sub>		100	175	ps	5
SD Assert	V <sub>SD assert</sub>	V <sub>CC</sub> – 0.5		V <sub>CC</sub>	V	6
SD De-Assert	V <sub>SD deassert</sub>	V <sub>EE</sub>		V <sub>EE</sub> +0.5	V	6
Power Supply Rejection	PSR	100			mVpp	7
Total Generated Receiver Jitter (peak to peak)	J <sub>RXP-P</sub>			0.07	UI	
Total Generated Receiver Jitter (rms)	J <sub>RXrms</sub>			0.007	UI	

### Notes:

1. Non condensing.
2. AC coupled.
3. Or open circuit.
4. Into 100 ohm differential termination.
5. 20 – 80 %
6. Signal Detect is LVTTTL. Logic 1 indicates normal operation; logic 0 indicates no signal detected.
7. All transceiver specifications are compliant with a power supply sinusoidal modulation of 20 Hz to 1.5 MHz up to specified value applied through the power supply filtering network shown on page 23 of the Small Form-factor Pluggable (SFP) Transceiver MultiSource Agreement (MSA), September 14, 2000.

**IV. Optical Characteristics (T<sub>OP</sub> = -40 to 85 °C, V<sub>CC</sub> = 3.00 to 3.60 Volts)**

Parameter	Symbol	Min	Typ	Max	Unit	Ref.
<b>Transmitter</b>						
Output Opt. Pwr: 9/125 SMF	P <sub>OUT</sub>	-9.5		-3	dBm	1
Optical Wavelength	$\lambda$	1270		1360	nm	2
Spectral Width	$\sigma$			3	nm	2
Optical Extinction Ratio	ER	8.2			dB	
Optical Rise/Fall Time	t <sub>r</sub> / t <sub>f</sub>			180	ps	3
Relative Intensity Noise	RIN			-120	dB/Hz	
Total Generated Transmitter Jitter (peak to peak)	J <sub>TXP-p</sub>			0.07	UI	
Total Generated Transmitter Jitter (rms)	J <sub>TXrms</sub>			0.007	UI	
<b>Receiver</b>						
Average Rx Sensitivity @ OC-48	R <sub>SENS1</sub>	0		-18	dBm	4
Average Rx Sensitivity @ 2X Fibre Channel	R <sub>SENS2</sub>	0		-21	dBm	5
Average Rx Sensitivity @ Gigabit Ethernet	R <sub>SENS3</sub>	0		-22	dBm	5
Average Rx Sensitivity @ OC-12	R <sub>SENS4</sub>	0		-22	dBm	6
Average Rx Sensitivity @ OC-3	R <sub>SENS5</sub>	-10		-23	dBm	6
Optical Center (Input) Wavelength	$\lambda_C$	1270		1600	nm	
Receiver Reflectance	R <sub>Rx</sub>			-27	dB	
SD Assert	SD <sub>A</sub>			-19	dBm	
SD De-Assert	SD <sub>D</sub>	-30			dBm	
SD Hysteresis		0.5			dB	

**Notes:**

- Class 1 Laser Safety per FDA/CDRH and EN (IEC) 60825 regulations.
- Also specified to meet curves in FC-PI 13.0 Figures 18 and 19, which allow trade-off between wavelength, spectral width and OMA.
- Unfiltered, 20 – 80%
- With worst-case extinction ratio. Measured with a PRBS 2<sup>31</sup>-1 test pattern interspersed with 72 consecutive ones and 72 consecutive zeros.
- With worst-case extinction ratio. Measured with a PRBS 2<sup>7</sup>-1 test pattern.
- With worst-case extinction ratio. Measured with a PRBS 2<sup>23</sup>-1 test pattern.

## V. General Specifications

Parameter	Symbol	Min	Typ	Max	Units	Ref.
Data Rate	BR	155		2667	Mb/sec	1
Bit Error Rate	BER			$10^{-12}$		2
Max. Supported Link Length on 9/125 $\mu$ m SMF @ OC-48	L <sub>MAX1</sub>		5		km	3
Max. Supported Link Length on 9/125 $\mu$ m SMF @ 2X Fibre Channel	L <sub>MAX2</sub>		10		km	3
Max. Supported Link Length on 9/125 $\mu$ m SMF @ Gigabit Ethernet	L <sub>MAX3</sub>		10		km	3
Max. Supported Link Length on 9/125 $\mu$ m SMF @ OC-12	L <sub>MAX4</sub>		10		km	3
Max. Supported Link Length on 9/125 $\mu$ m SMF @ OC-3	L <sub>MAX5</sub>		10		km	4

### Notes:

- SONET OC-48 SR/SDH STM I-16 compliant. Compatible with Gigabit Ethernet, 1x/2x Fibre Channel, SONET OC-12 and OC-3. Supports FEC at 2.67 Gb/s.
- Tested with a PRBS  $2^{31}-1$  test pattern interspersed with 72 consecutive ones and 72 consecutive zeros.
- Dispersion limited per FC-PI Rev. 13
- Attenuation of 0.55 dB/km is used for the link length calculations (per GR-253 CORE). Distances are indicative only. A 2dB penalty is included for dispersion on >2Gb/s data rates. Please refer to the Optical Specifications in Table IV to calculate a more accurate link budget based on specific conditions in your application.

## VI. Environmental Specifications

Finisar 1310nm SFP transceivers have an extended operating temperature range from  $-40^{\circ}\text{C}$  to  $+85^{\circ}\text{C}$  case temperature.

Parameter	Symbol	Min	Typ	Max	Units	Ref.
Case Operating Temperature	T <sub>op</sub>	-40		85	$^{\circ}\text{C}$	
Storage Temperature	T <sub>sto</sub>	-40		100	$^{\circ}\text{C}$	

## VII. Regulatory Compliance

Finisar transceivers are Class 1 Laser Products and comply with US FDA regulations. These products are certified by TÜV and CSA to meet the Class 1 eye safety requirements of EN (IEC) 60825 and the electrical safety requirements of EN (IEC) 60950. Copies of certificates are available at Finisar Corporation upon request.

**VIII. Analog Diagnostics Functions** ( $T_{op} = -40$  to  $85$  °C,  $V_{CC} = 3.00$  to  $3.60$  Volts)

Parameter	Symbol	Min	Typ	Max	Unit	Ref.
<b>Transmitter</b>						
Monitor photodiode current monitor	Pmon+, Pmon-	0		$V_{CC}$	V	1
Laser bias current monitor	Bmon+, Bmon-	0		$V_{CC}$	V	2
<b>Receiver</b>						
Received photocurrent	Rpd	0		1	mA	3
Photodiode responsivity	R	0.5	0.9	1.0	A/W	
Applied voltage at PD pin	Vpd	2.4		$V_{CC}$	V	3

Notes:

1. Pins 19 and 20 provide an analog voltage output proportional to the monitor photodiode current, per the following formula:  $I_{BIAS} = .V(Pmon+ - Pmon-) / 200\Omega$ . The figure below shows the equivalent circuit.
2. Pins 17 and 18 provide an analog voltage output proportional to the laser bias current, per the following formula:  $I_{BIAS} = .V(Bmon+ - Bmon-) / 10\Omega$ . The figure below shows the equivalent circuit.
3. Pin 1 is used to monitor the received photocurrent. It must be connected to a positive voltage within the range specified above. The current that flows into this pin is the received photocurrent. The received power is given by the photocurrent multiplied by the photodiode responsivity.

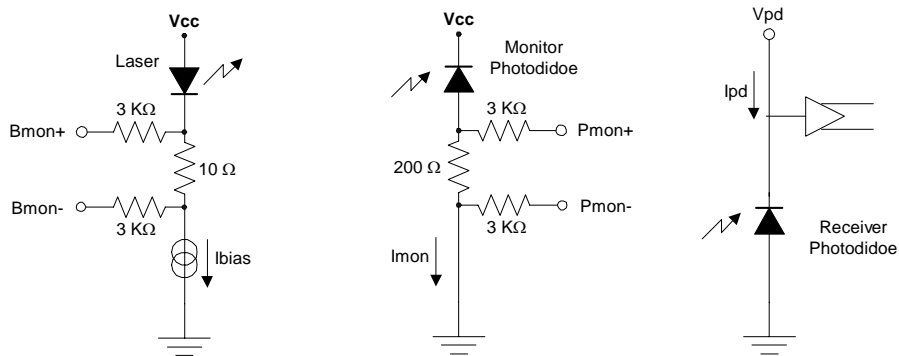
**Analog monitoring function connections.**

**IX. Mechanical Specifications**

Finisar’s OC-48/STM-16 Small Form Factor (SFF) transceivers comply with the standard dimensions defined by the Small Form Factor Multi-Sourcing Agreement (MSA).

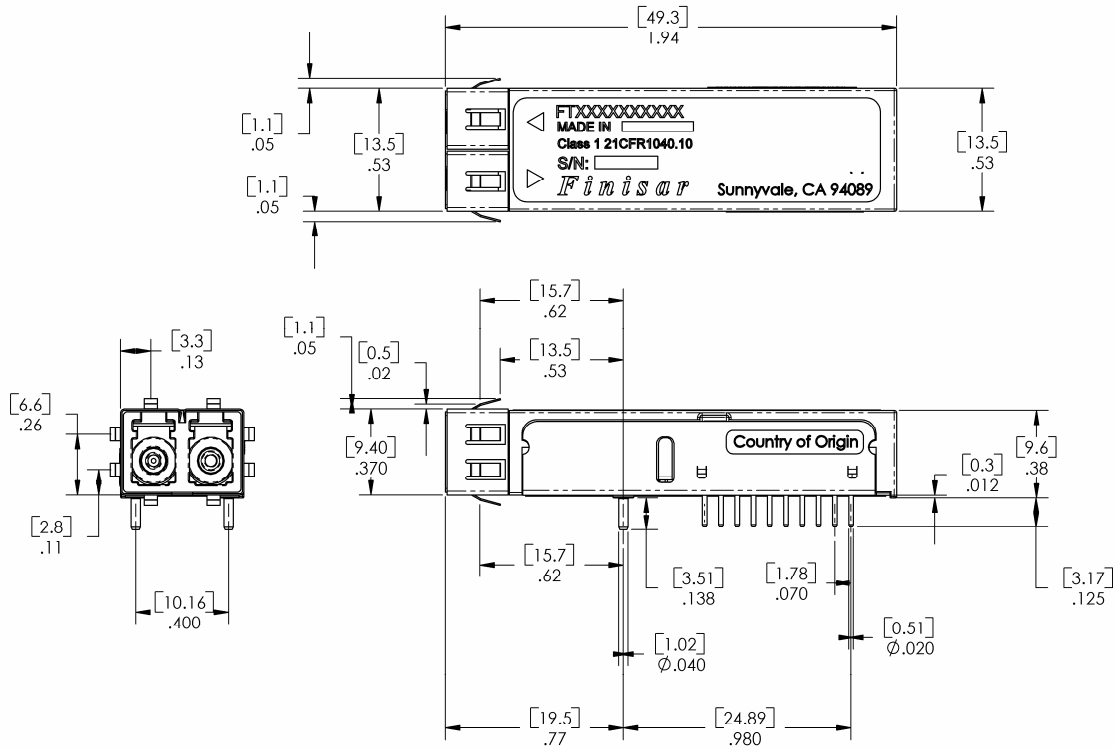

**FTLF1321S1GTL – 2 pin version**



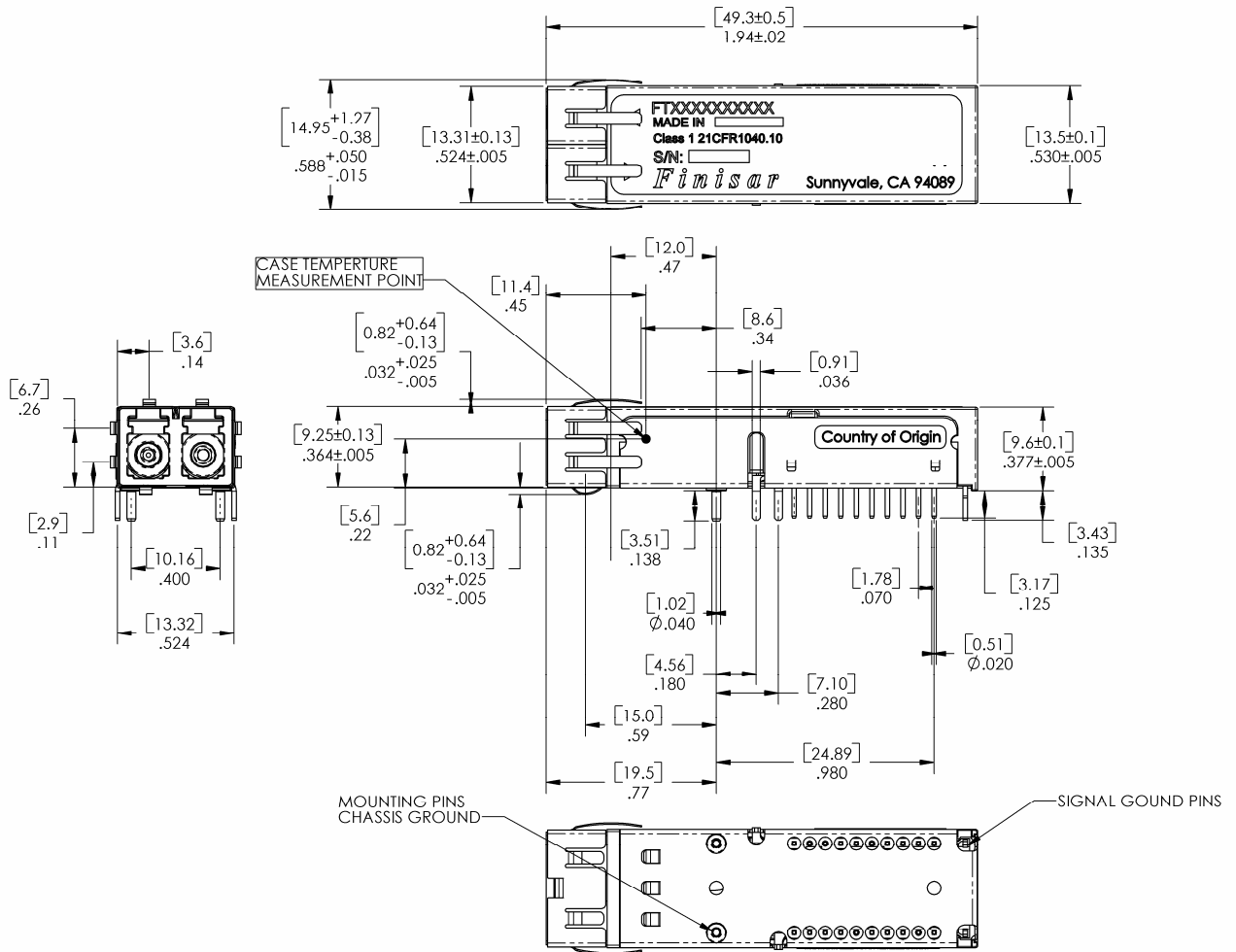

**FTLF1321S1HTL – 6 pin version (Long EMI Shield)**

**X. PCB Layout and Bezel Recommendations**

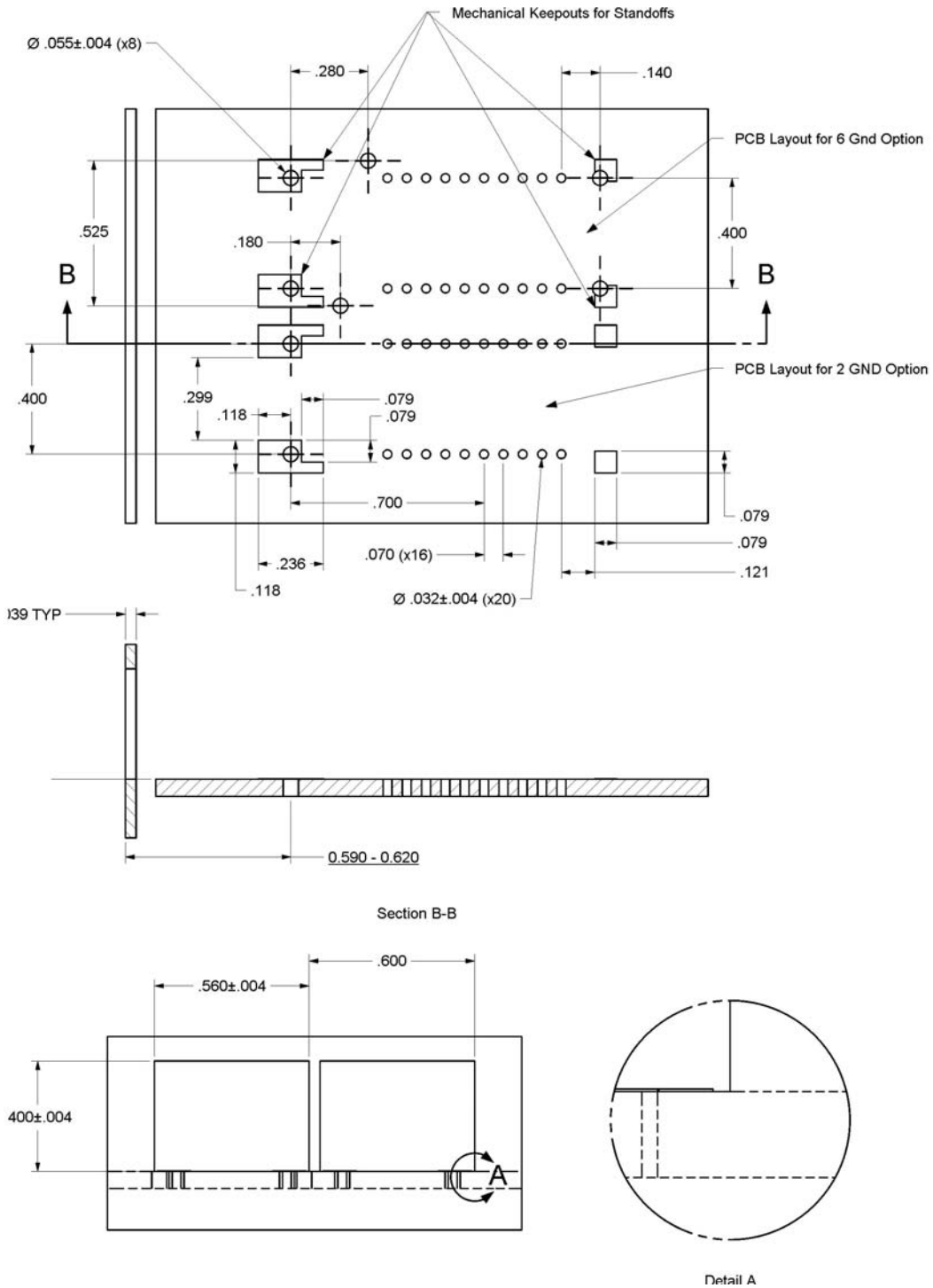

**Minimum Recommended Pitch is 0.600"**

**XI. References**



1. Small Form Factor (SFF) Transceiver Multisource Agreement (MSA). January 1998.
2. Bellcore GR-253 and ITU-T G.957 Specifications (Transmitter Optical Output Power complies with SONET OC-48 requirements only).
3. IEEE Std 802.3, 2002 Edition, Clause 38, PMD Type 1000BASE-LX. IEEE Standards Department, 2002. (Transmit Optical Output has a minimum Extinction Ratio of 8.2 dB only).
4. Directive 2002/95/EC of the European Council Parliament and of the Council. “On the restriction of the use of certain hazardous substances in electrical and electronic equipment”. January 27, 2003.
5. “Application Note AN-2038: Finisar Implementation of RoHS Compliant Transceivers: Finisar Corporation, January 21, 2005.
6. “Fibre Channel Draft Physical Interface Specification (FC-PI 13.0)”. American National Standard for Information Systems. (\*)

**XII. For More Information**

Finisar Corporation  
1308 Moffett Park Drive  
Sunnyvale, CA 94089-1133  
Tel. 1-408-548-1000  
Fax 1-408-541-6138  
[sales@finisar.com](mailto:sales@finisar.com)  
[www.finisar.com](http://www.finisar.com)

## Looking for pricing, stock, or lifecycle information?

Click below to explore more details on WIN SOURCE:

-  [View FTLF1321S1MTL on WIN SOURCE](#)
-  [Finisar Corporation Information](#)

## Optimize Your Supply Chain with WIN SOURCE Solutions

-  Global Sourcing Solution
-  Obsolete Management
-  Cost Control Management
-  Shortage Management
-  Alternative Solution
-  Excess Inventory Management