



**THE DATASHEET OF  
AD845SQ**



## AD845

### FEATURES

Replaces Hybrid Amplifiers in Many Applications

#### AC PERFORMANCE:

Settles to 0.01% in 350 ns

100 V/ $\mu$ s Slew Rate

12.8 MHz Min Unity Gain Bandwidth

1.75 MHz Full Power Bandwidth at 20 V p-p

#### DC PERFORMANCE:

0.25 mV Max Input Offset Voltage

5  $\mu$ V/ $^{\circ}$ C Max Offset Voltage Drift

0.5 nA Input Bias Current

250 V/mV Min Open-Loop Gain

4  $\mu$ V p-p Max Voltage Noise, 0.1 Hz to 10 Hz

94 dB Min CMRR

Available in Plastic Mini-DIP, Hermetic Cerdip, and SOIC Packages. Also Available in Tape and Reel in Accordance with EIA-481A Standard

### GENERAL DESCRIPTION

The AD845 is a fast, precise, N channel JFET input, monolithic operational amplifier. It is fabricated using Analog Devices' complementary bipolar (CB) process. Advanced laser-wafer trimming technology enables the very low input offset voltage and offset voltage drift performance to be realized. This precision, when coupled with a slew rate of 100 V/ $\mu$ s, a stable unity gain bandwidth of 16 MHz, and a settling time of 350 ns to 0.01%—while driving a parallel load of 100 pF and 500  $\Omega$ —represents a combination of features unmatched by any FET input IC amplifier. The AD845 can easily be used to upgrade many existing designs that use BiFET or FET input hybrid amplifiers and, in some cases, those which use bipolar input op amps.

The AD845 is ideal for use in applications such as active filters, high speed integrators, photodiode preamps, sample-and-hold amplifiers, and log amplifiers, and for buffering A/D and D/A converters. The 250  $\mu$ V max input offset voltage makes offset nulling unnecessary in many applications. The common-mode rejection ratio of 110 dB over a  $\pm 10$  V input voltage range represents exceptional performance for a JFET input high speed op amp. This, together with a minimum open-loop gain of 250 V/mV ensures that 12-bit performance is achieved, even in unity gain buffer circuits.

REV. E

Information furnished by Analog Devices is believed to be accurate and reliable. However, no responsibility is assumed by Analog Devices for its use, nor for any infringements of patents or other rights of third parties that may result from its use. No license is granted by implication or otherwise under any patent or patent rights of Analog Devices. Trademarks and registered trademarks are the property of their respective owners.

### CONNECTION DIAGRAMS

Plastic Mini-DIP (N) Package  
and Cerdip (Q) Package

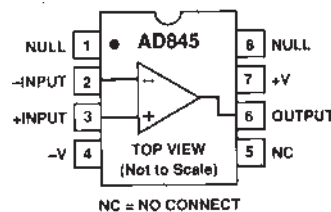

16-Lead SOIC  
(R-16) Package

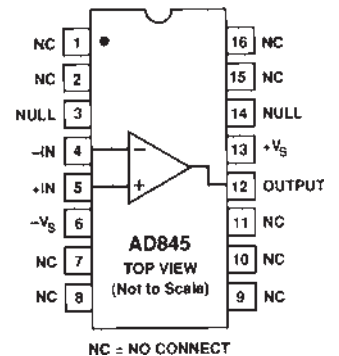

The AD845 conforms to the standard op amp pinout except that offset nulling is to V+. The AD845J and AD845K grade devices are available specified to operate over the commercial 0 $^{\circ}$ C to 70 $^{\circ}$ C temperature range. AD845A and AD845B devices are specified for operation over the -40 $^{\circ}$ C to +85 $^{\circ}$ C industrial temperature range. The AD845S is specified to operate over the full military temperature range of -55 $^{\circ}$ C to +125 $^{\circ}$ C. Both the industrial and military versions are available in 8-lead Cerdip packages. The commercial version is available in an 8-lead plastic mini-DIP and 16-lead SOIC; J and S grade chips are also available.

### PRODUCT HIGHLIGHTS

1. The high slew rate, fast settling time, and dc precision of the AD845 make it ideal for high speed applications requiring 12-bit accuracy.
2. The performance of circuits using the LF400, HA2520, HA2522, HA2525, HA2620, HA2622, HA2625, 3550, OPA605, and LH0062 can be upgraded in most cases.
3. The AD845 is unity gain stable and internally compensated.
4. The AD845 is specified while driving 100 pF/500  $\Omega$  loads.

# AD845—SPECIFICATIONS (@ 25°C and ±15 V dc, unless otherwise noted.)

Parameter	Conditions	AD845J/A			AD845K/B			AD845S			Unit			
		Min	Typ	Max	Min	Typ	Max	Min	Typ	Max				
INPUT OFFSET VOLTAGE <sup>1</sup>	T <sub>MIN</sub> to T <sub>MAX</sub>	Initial Offset			0.7	1.5	2.5	0.1	0.25	0.4	0.25	1.0	mV	
		Offset Drift				20		1.5	5.0		10		μV/°C	
INPUT BIAS CURRENT <sup>2</sup>	V <sub>CM</sub> = 0 V T <sub>MIN</sub> to T <sub>MAX</sub>	Initial			0.75	2	45/75	0.5	1	18/38	0.75	2	500	nA
														nA
INPUT OFFSET CURRENT	V <sub>CM</sub> = 0 V T <sub>MIN</sub> to T <sub>MAX</sub>	Initial			25	300	3/6.5	15	100	1.2/2.6	25	300	20	pA
														nA
INPUT CHARACTERISTICS		Input Resistance			10 <sup>11</sup>			10 <sup>11</sup>			10 <sup>11</sup>			kΩ
		Input Capacitance			4.0			4.0			4.0			pF
INPUT VOLTAGE RANGE	V <sub>CM</sub> = ±10 V	Differential			±20			±20			±20			V
		Common-Mode			±10	+10.5/-13		±10	+10.5/-13		±10	+10.5/-13		V
		Common-Mode Rejection			86	110		94	113		86	110		dB
INPUT VOLTAGE NOISE	0.1 Hz to 10 Hz	f = 10 Hz			4			4			4			μV p-p
		f = 100 Hz			80			80			80			nV/√Hz
		f = 1 kHz			60			60			60			nV/√Hz
		f = 10 kHz			25			25			25			nV/√Hz
		f = 100 kHz			18			18			18			nV/√Hz
		f = 100 kHz			12			12			12			nV/√Hz
INPUT CURRENT NOISE	f = 1 kHz	0.1			0.1			0.1			0.1			pA/√Hz
OPEN-LOOP GAIN	V <sub>O</sub> = ±10 V R <sub>LOAD</sub> ≥ 2 kΩ R <sub>LOAD</sub> ≥ 500 Ω T <sub>MIN</sub> -T <sub>MAX</sub>	200			500			250			500			V/mV
		100			250			125			250			V/mV
		70						75			50			V/mV
														V/mV
OUTPUT CHARACTERISTICS	R <sub>LOAD</sub> ≥ 500 Ω Short Circuit Open Loop	±12.5			±12.5			±12.5			±12.5			V
		50			50			50			50			mA
		5			5			5			5			Ω
FREQUENCY RESPONSE	Unity Gain V <sub>O</sub> = ±10 V R <sub>LOAD</sub> = 500 Ω	12.8			16			13.6			16			MHz
		1.75			1.75			1.75			1.75			MHz
		20			20			20			20			ns
		20			20			20			20			%
		80			100			94			100			V/μs
		350			250			350			500			ns
DIFFERENTIAL GAIN	f = 4.4 MHz	0.04			0.04			0.04			0.04			%
DIFFERENTIAL PHASE	f = 4.4 MHz	0.02			0.02			0.02			0.02			Degree
POWER SUPPLY	V <sub>S</sub> = ±5 to ±15 V T <sub>MIN</sub> to T <sub>MAX</sub>	±15			±15			±15			±15			V
		±4.75			±18			±4.75			±18			V
		88			110			95			113			dB
		10			12			10			12			mA

## NOTES

<sup>1</sup>Input offset voltage specifications are guaranteed after five minutes of operation at T<sub>A</sub> = 25°C.

<sup>2</sup>Bias current specifications are guaranteed maximum at either input after five minutes of operation at T<sub>A</sub> = 25°C.

<sup>3</sup>FPBW = slew rate/2 π V peak.

<sup>4</sup>S grade T<sub>MIN</sub>-T<sub>MAX</sub> are tested with automatic test equipment at T<sub>A</sub> = -55°C and T<sub>A</sub> = +125°C.

All min and max specifications are guaranteed. Specifications shown in **boldface** are tested on all production units at final electrical test. Results from these tests are used to calculate outgoing quality levels.

Specifications subject to change without notice.

**ABSOLUTE MAXIMUM RATINGS<sup>1</sup>**

Supply Voltage . . . . . ±18 V

Internal Power Dissipation<sup>2</sup>

    Plastic Mini-DIP . . . . . 1.6 W

    CERDIP . . . . . 1.4 W

    16-Lead SOIC . . . . . 1.5 W

Input Voltage . . . . . +V<sub>S</sub>

Output Short-Circuit Duration . . . . . Indefinite

Differential Input Voltage . . . . . +V<sub>S</sub> and -V<sub>S</sub>

Storage Temperature Range

    Q . . . . . -65°C to +150°C

    N, R . . . . . -65°C to +125°C

Lead Temperature Range (Soldering 60 sec) . . . . . 300°C

**NOTES**

<sup>1</sup>Stresses above those listed under Absolute Maximum Ratings may cause permanent damage to the device. This is a stress rating only, and functional operation of the device at these or any other conditions above those indicated in the operational sections of this specification is not implied. Exposure to absolute maximum rating conditions for extended periods may affect device reliability.

<sup>2</sup>Mini-DIP package:  $\theta_{JA} = 100^\circ\text{C/W}$ ; CERDIP package:  $\theta_{JA} = 110^\circ\text{C/W}$ ; SOIC package:  $\theta_{JA} = 100^\circ\text{C/W}$ .

**METALIZATION PHOTOGRAPH**

Dimensions shown in inches and (mm).  
Contact factory for latest dimensions.

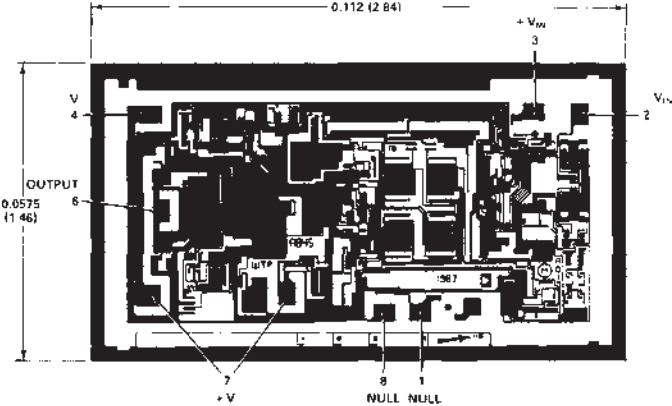

**ORDERING GUIDE**

Model	Temperature Range	Package Description	Package Option <sup>1</sup>
AD845JN	0°C to 70°C	8-Lead PDIP	N-8
AD845KN	0°C to 70°C	8-Lead PDIP	N-8
AD845JR-16	0°C to 70°C	16-Lead SOIC	R-16
AD845JR-16-REEL	0°C to 70°C	Tape and Reel	R-16
AD845JR-16-REEL7	0°C to 70°C	Tape and Reel	R-16
AD845AQ	-40°C to +85°C	8-Lead CERDIP	Q-8
AD845BQ	-40°C to +85°C	8-Lead CERDIP	Q-8
AD845SQ	-55°C to +125°C	8-Lead CERDIP	Q-8
AD845SQ/883B	-55°C to +125°C	8-Lead CERDIP	Q-8
5962-8964501PA <sup>2</sup>	-55°C to +125°C	8-Lead CERDIP	Q-8
AD845JCHIPS	0°C to 70°C	Die	

**NOTES**

<sup>1</sup>N = Plastic DIP; Q = CERDIP; R = Small Outline IC (SOIC).

<sup>2</sup>See military data sheet.

# AD845—Typical Performance Characteristics

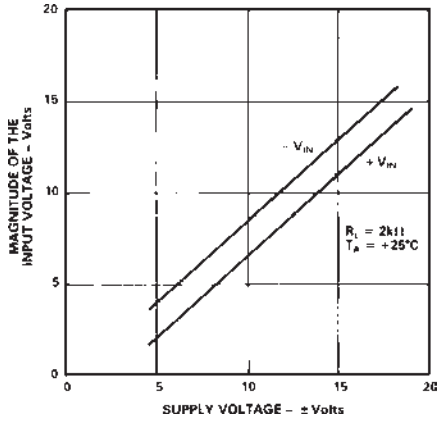

TPC 1. Input Voltage Swing vs. Supply Voltage

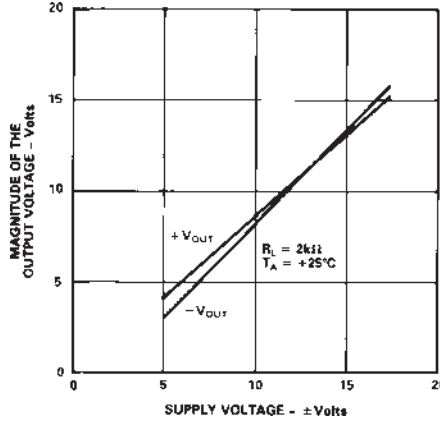

TPC 2. Output Voltage Swing vs. Supply Voltage

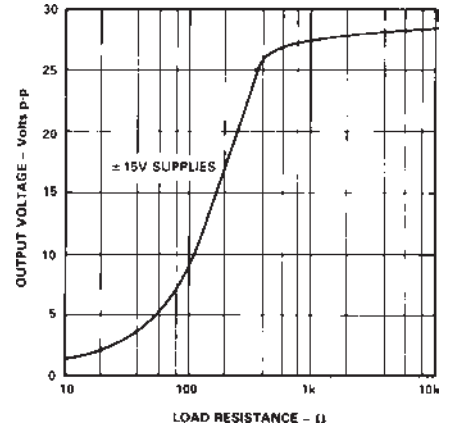

TPC 3. Output Voltage Swing vs. Resistive Load

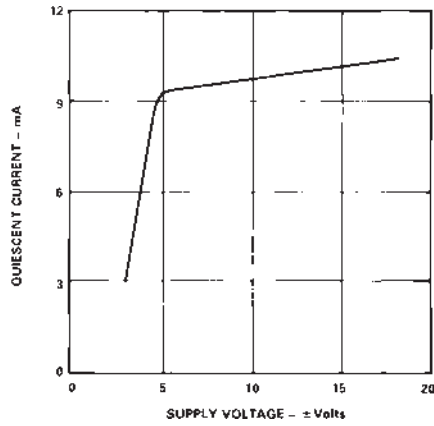

TPC 4. Quiescent Current vs. Supply Voltage

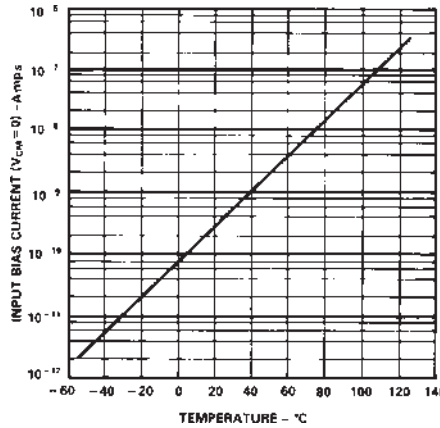

TPC 5. Input Bias Current vs. Temperature

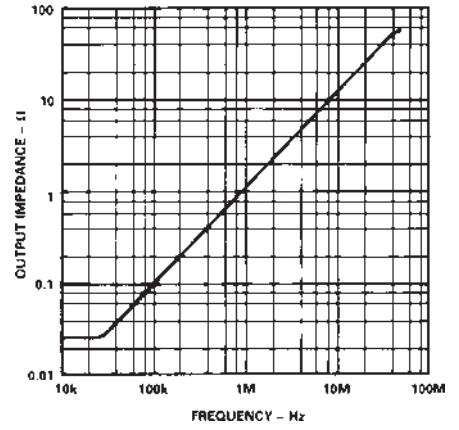

TPC 6. Magnitude of Output Impedance vs. Frequency

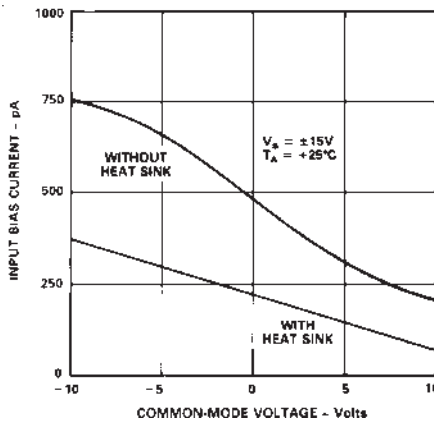

TPC 7. Input Bias Current vs. Common-Mode Voltage

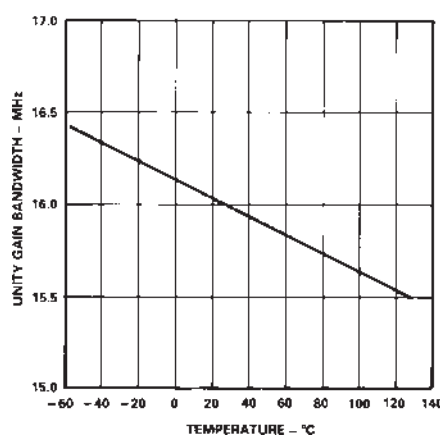

TPC 8. Short-Circuit Current Limit vs. Temperature

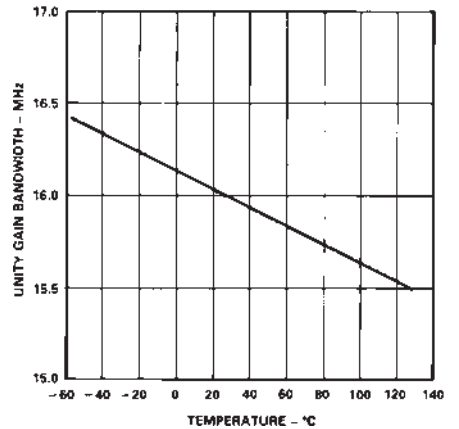

TPC 9. Unity-Gain Bandwidth vs. Temperature

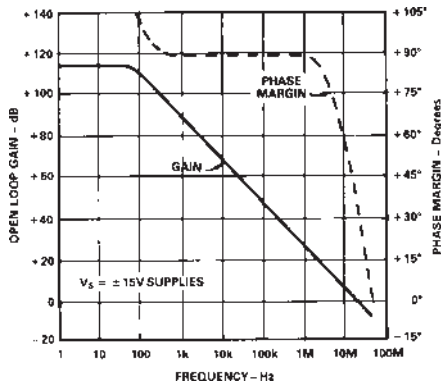

TPC 10. Open-Loop Gain and Phase Margin vs. Frequency

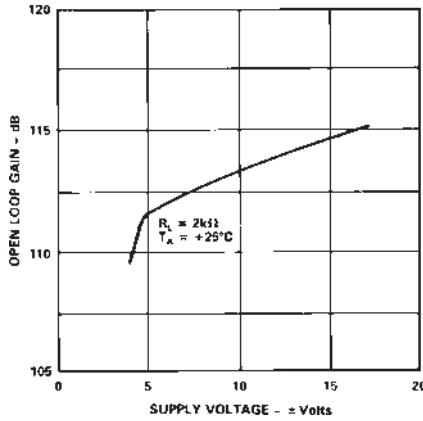

TPC 11. Open-Loop Gain vs. Supply Voltage

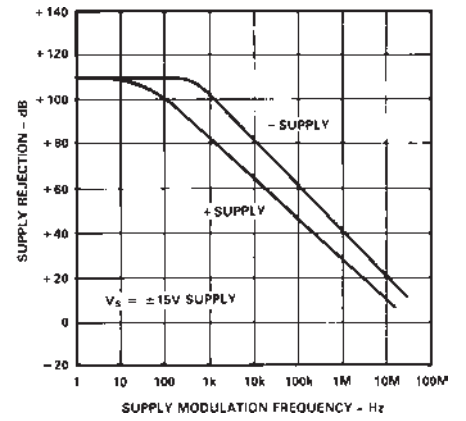

TPC 12. Power Supply Rejection vs. Frequency

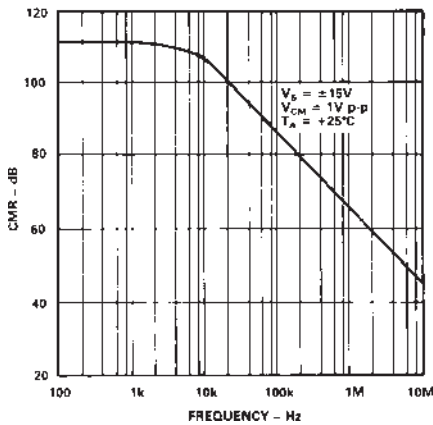

TPC 13. Common-Mode Rejection vs. Frequency

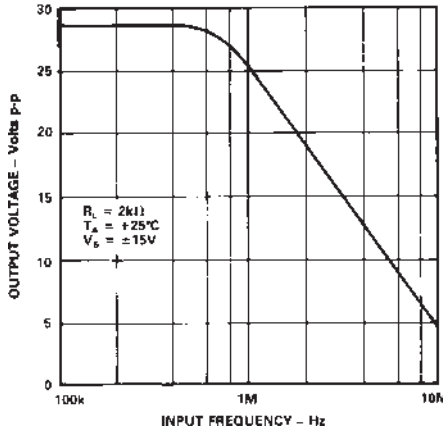

TPC 14. Large Signal Frequency Response

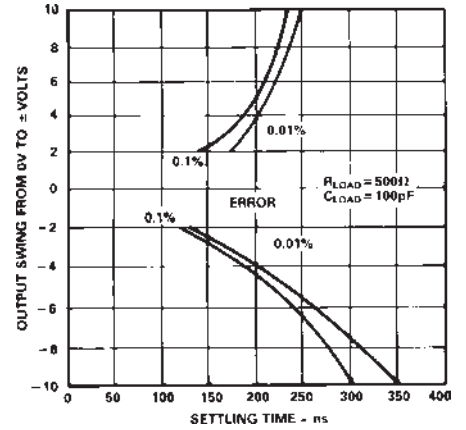

TPC 15. Output Swing and Error vs. Settling Time

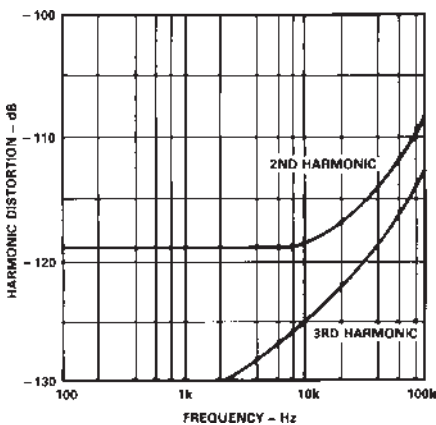

TPC 16. Harmonic Distortion vs. Frequency

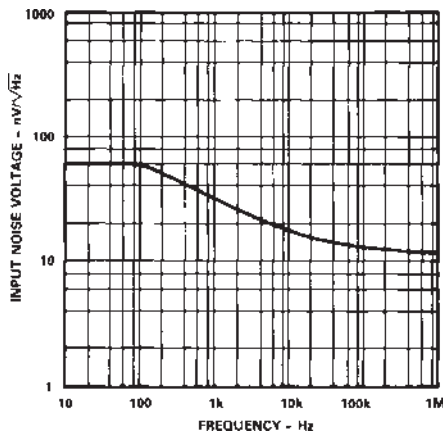

TPC 17. Input Noise Voltage Spectral Density

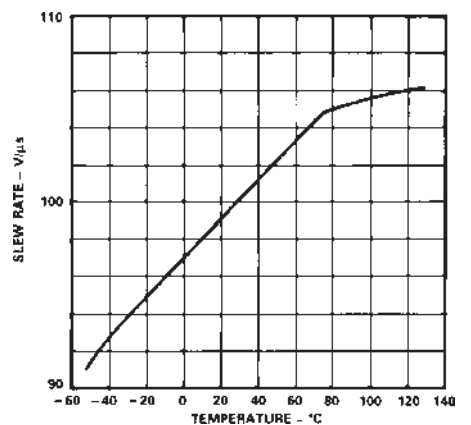

TPC 18. Slew Rate vs. Temperature

# AD845

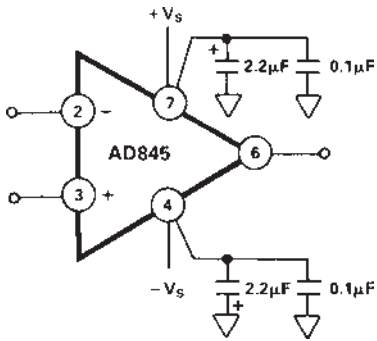

TPC 19. Recommended Power Supply Bypassing

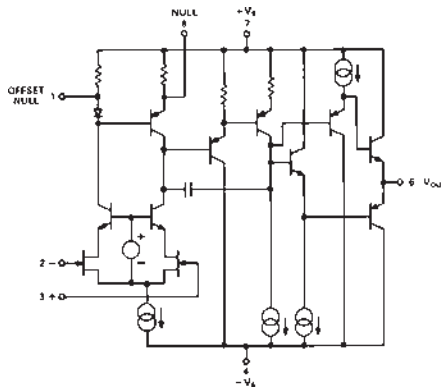

TPC 20. AD845 Simplified Schematic

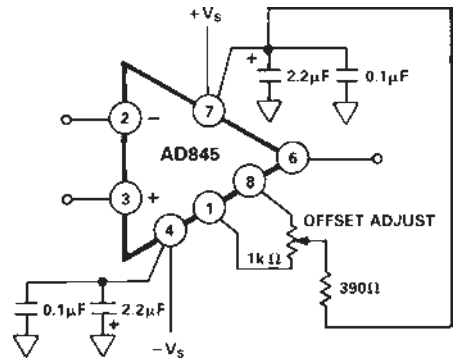

TPC 21. Offset Null Configuration

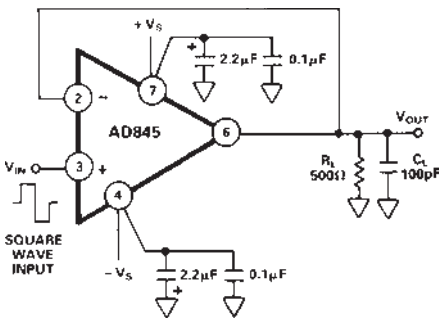

TPC 22. Unity Gain Follower

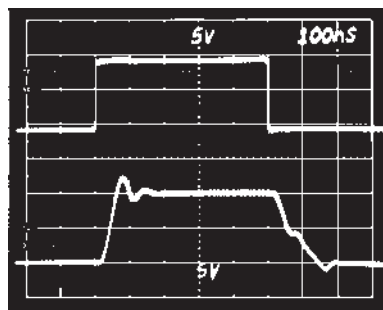

TPC 23. Unity Gain Follower Large Signal Pulse Response

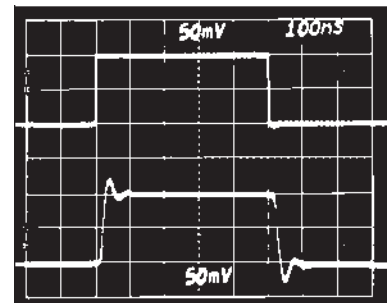

TPC 24. Unity Gain Follower Small Signal Pulse Response

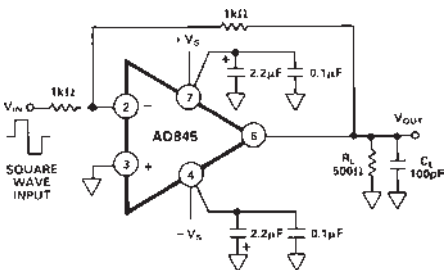

TPC 25. Unity Gain Inverter

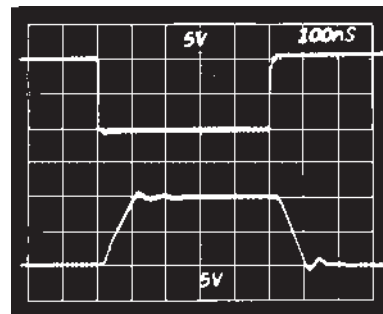

TPC 26. Unity Gain Inverter Large Signal Pulse Response

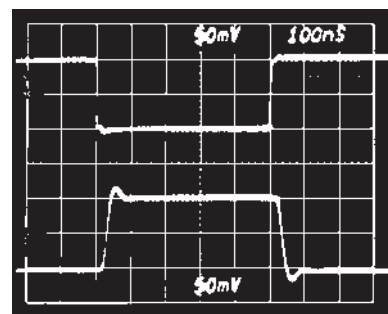

TPC 27. Unity Gain Inverter Small Signal Pulse Response

## MEASURING AD845 SETTling TIME

Figure 1 shows AD845 settling time performance. This measurement was accomplished by driving the amplifier in the unity gain inverting mode with a fast pulse generator. The input summing junction was measured using false nulling techniques.

Settling time is defined as the interval of time from the application of an ideal step function input until the closed-loop amplifier output has entered and remains within a specified error band.

Components of settling time include:

1. Propagation time through the amplifier
2. Slewing time to approach the final output value
3. Recovery time from overload associated with the slewing
4. Linear settling to within a specified error band

These individual components can be seen easily in Figure 1. Settling time is extremely important in high speed applications where the current output of a DAC must be converted to a voltage. When driving a 500 Ω load in parallel with a 100 pF capacitor, the AD845 settles to 0.1% in 250 ns and to 0.01% in 310 ns.

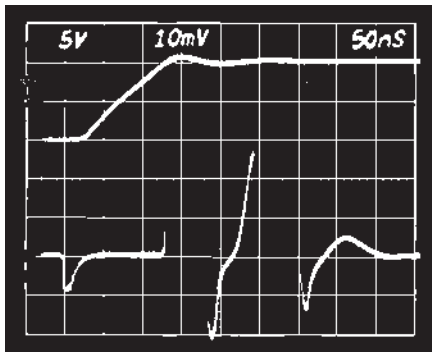

Figure 1. Settling Characteristics 0 V to 10 V Step  
Upper Trace: Output of AD845 Under Test (5 V/Div)  
Lower Trace: Error Voltage (1 mV/Div)

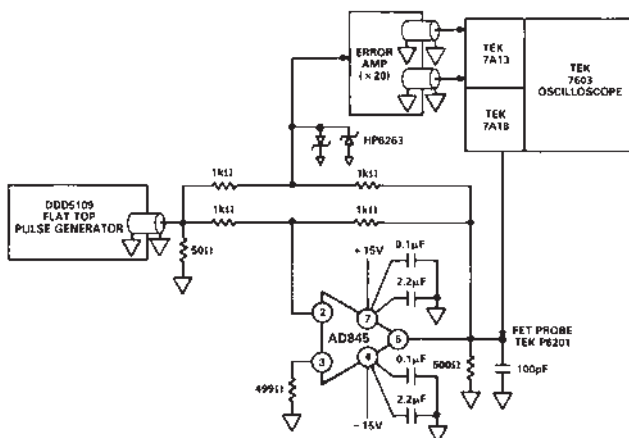

Figure 2. Settling Time Test Circuit

## A HIGH SPEED INSTRUMENTATION AMP

The 3-op amp instrumentation amplifier circuit shown in Figure 3 can provide a range of gains from unity up to 1000 and higher. The instrumentation amplifier configuration features high common-mode rejection, balanced differential inputs, and

stable, accurately defined gain. Low input bias currents and fast settling are achieved with the FET input AD845.

Most monolithic instrumentation amplifiers do not have the high frequency performance of the circuit in Figure 3. The circuit bandwidth is 10.9 MHz at a gain of 1 and 8.8 MHz at a gain of 10; settling time for the entire circuit is 900 ns to 0.01% for a 10 V step (Gain = 10).

The capacitors employed in this circuit greatly improve the amplifier's settling time and phase margin.

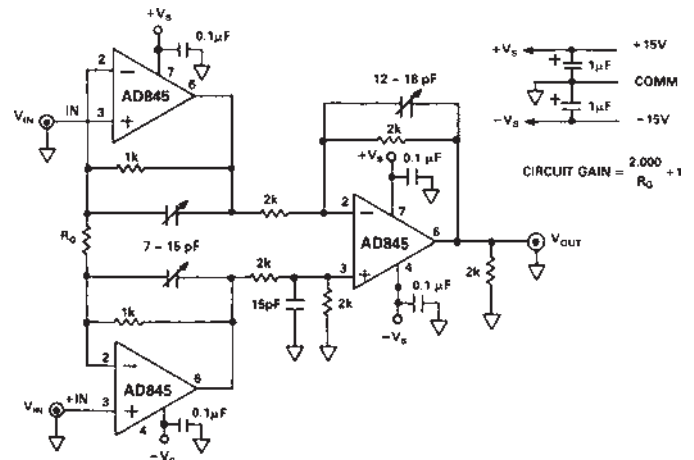

Figure 3. High Performance, High Speed Instrumentation Amplifier

Table I. Performance Summary for the 3-Op Amp Instrumentation Amplifier Circuit

3-Op Amp In-Amp			
Gain	R <sub>G</sub>	Small Signal Bandwidth	Settling Time to 0.01%
1	Open	10.9 MHz	500 ns
2	2 kΩ	8.8 MHz	500 ns
10	226 Ω	2.6 MHz	900 ns
100	20 Ω	290 kHz	7.5 μs

Note: Resistors around the amplifiers' input pins need to be small enough in value so that the RC time constant they form, with stray circuit capacitance, does not reduce circuit bandwidth.

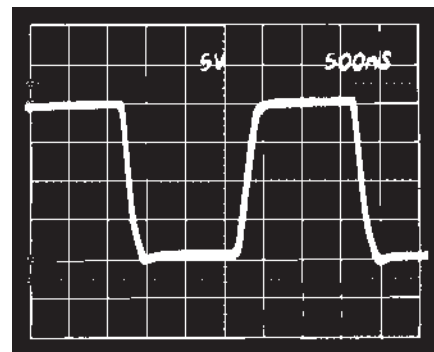

Figure 4. The Pulse Response of the 3-Op Amp Instrumentation Amplifier. Gain = 1, Horizontal Scale = 0.5 ms/Div and Vertical Scale = 5 V/Div.

# AD845

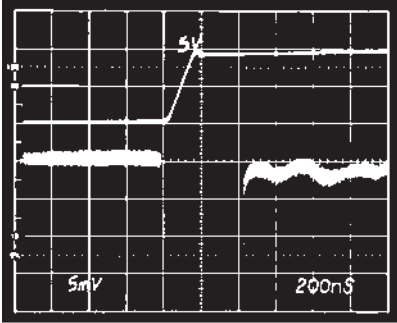

Figure 5. Settling Time of the 3-Op Amp Instrumentation Amplifier. Horizontal Scale is 200 ns/Div, Vertical Scale, Positive Pulse Input is 5 V/Div and Output Settling is 1 mV/Div.

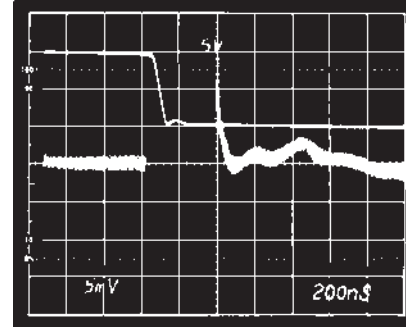

Figure 6. Settling Time of the Three Op Amp Instrumentation Amplifier. Horizontal Scale: 200 ns/Div; Vertical Scale, Negative Pulse Input: 5 V/Div; Output Settling: 1 mV/Div.

## DRIVING THE ANALOG INPUT OF AN A/D CONVERTER

An op amp driving the analog input of an A/D converter, such as that shown in Figure 7, must be capable of maintaining a constant output voltage under dynamically changing load conditions. In successive approximation converters, the input current is compared to a series of switched trial currents. The comparison point is diode clamped but may deviate several hundred millivolts, resulting in high frequency modulation of A/D input current. The output impedance of a feedback amplifier is made artificially low by the loop gain. At high frequencies, where the loop gain is low, the amplifier output impedance can approach its open-loop value. Most IC amplifiers exhibit a minimum open-loop output impedance of 25  $\Omega$  due to current limiting resistors. A few hundred microamps reflected from the change in converter loading can introduce errors in instantaneous input voltage. If the A/D conversion speed is not excessive and the bandwidth of the amplifier is sufficient, the amplifier's output will return to the nominal value before the converter makes its comparison. However, many amplifiers have relatively narrow bandwidth, yielding slow recovery from output transients. The

AD845 is ideally suited to drive high resolution A/D converters with 5  $\mu$ s or longer conversion times since it offers both wide bandwidth and high open-loop gain.

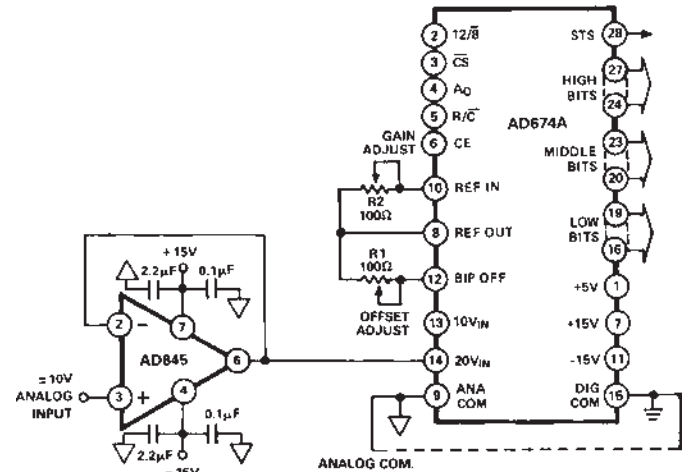

Figure 7. AD845 As ADC Unity Gain Buffer

OUTLINE DIMENSIONS

8-Lead Plastic Dual In-Line Package [PDIP]

(N-8)

Dimensions shown in inches and (millimeters)

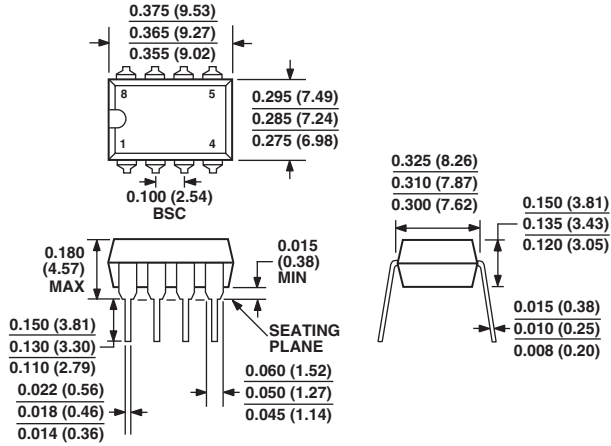

COMPLIANT TO JEDEC STANDARDS MO-095AA

CONTROLLING DIMENSIONS ARE IN INCHES; MILLIMETER DIMENSIONS (IN PARENTHESES) ARE ROUNDED-OFF INCH EQUIVALENTS FOR REFERENCE ONLY AND ARE NOT APPROPRIATE FOR USE IN DESIGN

16-Lead Standard Small Outline Package [SOIC]

Wide Body

(R-16)

Dimensions shown in millimeters and (inches)

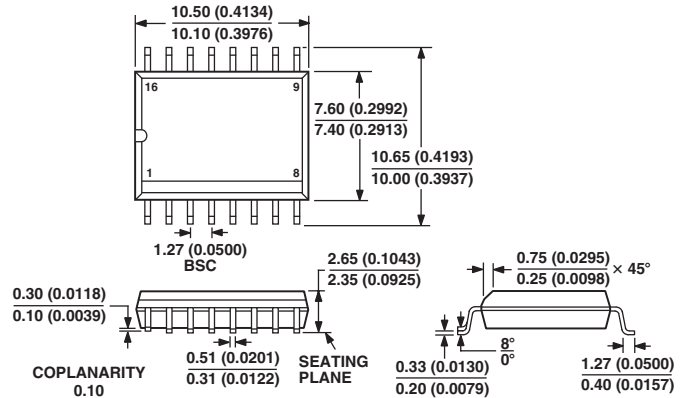

COMPLIANT TO JEDEC STANDARDS MS-013AA  
CONTROLLING DIMENSIONS ARE IN MILLIMETERS; INCH DIMENSIONS (IN PARENTHESES) ARE ROUNDED-OFF MILLIMETER EQUIVALENTS FOR REFERENCE ONLY AND ARE NOT APPROPRIATE FOR USE IN DESIGN

8-Lead Ceramic Dual In-Line Package [CERDIP]

(Q-8)

Dimensions shown in inches and (millimeters)

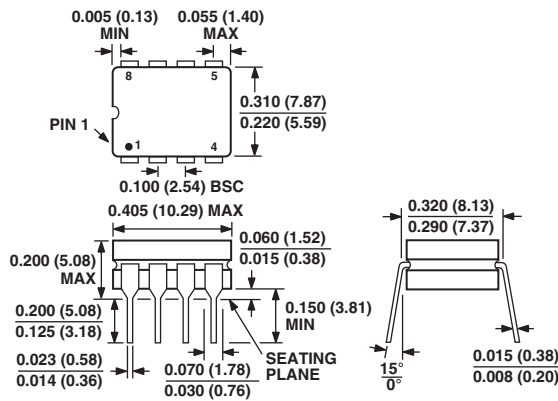

CONTROLLING DIMENSIONS ARE IN INCHES; MILLIMETERS DIMENSIONS (IN PARENTHESES) ARE ROUNDED-OFF INCH EQUIVALENTS FOR REFERENCE ONLY AND ARE NOT APPROPRIATE FOR USE IN DESIGN

# AD845

## Revision History



<b>Location</b>	<b>Page</b>
<hr/>	
10/03—Data Sheet changed from REV. D to REV. E.	
Renumbered figures and TPCs .....	Universal
Updated OUTLINE DIMENSIONS .....	9





## Looking for pricing, stock, or lifecycle information?

Click below to explore more details on WIN SOURCE:

-  [View AD845SQ on WIN SOURCE](#)
-  [Analog Devices Inc. Information](#)

## Optimize Your Supply Chain with WIN SOURCE Solutions

-  Global Sourcing Solution
-  Obsolete Management
-  Cost Control Management
-  Shortage Management
-  Alternative Solution
-  Excess Inventory Management