



**THE DATASHEET OF
UCD3138ARGCT**



UCD3138A Highly-Integrated Digital Controller for Isolated Power

1 Device Overview

1.1 Features

- Digital Control of up to 3 Independent Feedback Loops
 - Dedicated PID-Based Hardware
 - 2-Pole, 2-Zero Configurable
 - Nonlinear Control
- Soft-Start and Soft-Stop with and without Prebias
- Fast Input Voltage Feed Forward Hardware
- Synchronous Rectifier Dead Time Optimization Peripheral to Use with UCD7138 Synchronous Rectifier Driver
- Up to 16 MHz Error Analog-to-Digital Converter (EADC)
 - Configurable Resolution as Small as 1 mV/LSB
 - Automatic Resolution Selection
 - Up to 8x Oversampling
 - Hardware-Based Averaging (up to 8x)
 - 10-Bit Effective DAC With 4 Bits of Dither
 - Adaptive Sample Trigger Positioning
- Up to 8 High-Resolution Digital Pulse Width Modulated (DPWM) Outputs
 - 250-ps Pulse Width Resolution
 - 4-ns Frequency and Phase Resolution
 - Adjustable Phase-Shift Between Outputs
 - Adjustable Dead-band Between Pairs
 - Cycle-by-Cycle Duty Cycle Matching
 - Up to 2-MHz Switching Frequency
- Configurable PWM Edge Movement
 - Trailing Modulation
 - Leading Modulation
 - Triangular Modulation
- Configurable Feedback Control
 - Voltage Mode
 - Average Current Mode
 - Peak Current Mode Control
 - Constant Current
 - Constant Power
- Configurable Modulation Methods
 - Frequency Modulation
 - Phase-Shift Modulation
 - Pulse Width Modulation
- Fast, Automatic, and Smooth Mode Switching
 - Frequency Modulation and PWM
 - Phase-Shift Modulation and PWM
 - Frequency Modulation and Phase-Shift Modulation
- High Efficiency and Light Load Management
 - Burst Mode
 - Ideal Diode Emulation
 - Synchronous Rectifier Soft On/Off
 - Low IC Standby Power
- Primary Side Voltage Sensing
- Copper Trace Current Sensing
- Flux and Phase Current Balancing
- Current Share Bus Support
 - Average or Master and Slave
- Feature Rich Fault Protection Options
 - 7 High-Speed Analog Comparators
 - Cycle-by-Cycle Current Limiting
 - Programmable Fault
 - External Fault Capability
 - 10 Digital Comparators
 - Programmable Blanking Time
- Synchronization of DPWM Waveforms Between Multiple UCD3138A devices
- 14-Channel, 12-Bit, 267-ksps General-Purpose ADC
 - Programmable Averaging Filters
 - Dual Sample and Hold
- Internal Temperature Sensor
- Fully Programmable High-Performance 31.25-MHz, 32-Bit ARM7TDMI-S™ Processor
 - 32 KB of Program Flash
 - 2 KB of Data Flash with ECC
 - 4 KB of Data RAM
 - Firmware Boot-Load in the Field via PMBus or UART
- Communication Peripherals
 - PMBus
 - 1 UART
- UART Auto-baud Rate Adjustment
- Timer Capture with Selectable Input Pins
- Up to 5 Additional General Purpose Timers
- Built In Watchdog: BOD and POR
- 64-Pin QFN and 40-Pin QFN Package
- Operating Temperature: –40°C to +125°C
- Debug Interface
 - Code Composer Studio™ with JTAG Interface
 - Fusion Digital Power™ Designer GUI Support



1.2 Applications

- Power Supplies and Telecom Rectifiers
- Power Factor Correction
- Isolated DC-DC Modules

1.3 Description

The UCD3138A is a digital power supply controller from Texas Instruments offering superior levels of integration and performance in a single-chip solution. The flexible nature of the UCD3138A makes it suitable for a wide variety of power conversion applications. In addition, multiple peripherals inside the device have been specifically optimized to enhance the performance of AC-DC and isolated DC-DC applications and reduce the solution component count in the IT and network infrastructure space.

The UCD3138A controller is a fully programmable solution offering customers complete control of their application, along with ample ability to differentiate their solution. At the same time, TI is committed to simplifying our customers' development effort by offering best-in-class development tools, including application firmware, [Code Composer Studio™](#) software development environment, and TI's power development GUI which lets customers configure and monitor key system parameters.

At the core of the UCD3138A controller are the digital control loop peripherals, also known as Digital Power Peripherals (DPPs). Each DPP implements a high-speed digital control loop consisting of a dedicated error analog-to-digital converter (EADC), a PID-based 2-pole-2-zero digital compensator and DPWM outputs with 250-ps pulse width resolution. The device also contains a 12-bit, 267-ksps general-purpose ADC with up to 14 channels, timers, interrupt control, PMBus, and UART communications ports. The device is based on a 32-bit ARM7TDMI-S RISC microcontroller that performs real-time monitoring, configures peripherals, and manages communications. The ARM microcontroller executes its program out of programmable flash memory as well as on-chip RAM and ROM.

In addition to the DPP, specific power management peripherals have been added to enable high efficiency across the entire operating range, high integration for increased power density, reliability, and lowest overall system cost and high flexibility with support for the widest number of control schemes and topologies. Such peripherals include: light load burst mode, synchronous rectification, automatic mode switching, input voltage feed forward, copper trace current sense, ideal diode emulation, constant current constant power control, synchronous rectification soft on and off, peak current mode control, flux balancing, secondary side input voltage sensing, high-resolution current sharing, hardware-configurable soft-start operation with pre-bias, as well as several other features. The device optimizes topology support for voltage mode and peak current mode controlled phase-shifted full bridge, single and dual phase PFC, bridge-less PFC, hard-switched full bridge and half bridge, and LLC half bridge and full bridge.

The UCD3139A is a functional variant of the UCD3138A Digital Power Controller that includes significant improvements over the UCD3138 device. For a description of the complete changes made in the UCD3138A, refer to *UCD3138A Migration Guide*.

Device Information⁽¹⁾

DEVICE NUMBER	PACKAGE DRAWING	PACKAGE TYPE	BODY SIZE
UCD3138A	RGC	VQFN (64)	9.00 mm x 9.00 mm
	RJA	VQFN (40) ⁽³⁾	6.00 mm x 6.00 mm
	RMH	WQFN (40)	6.00 mm x 6.00 mm

(1) For all available packages, see the orderable addendum at the end of the datasheet.

(2) 40-pin 6 x 6 x 0.75 mm ultra-thin QFN with corner anchors optimized for IPC9592A Temperature Cycle Testing.

(3) Recommended for new 40-pin designs, optimized for improved performance under temperature cycling test for board level reliability (BLR).

1.4 Functional Block Diagram

Figure 1-1 shows a functional block diagram of the device.

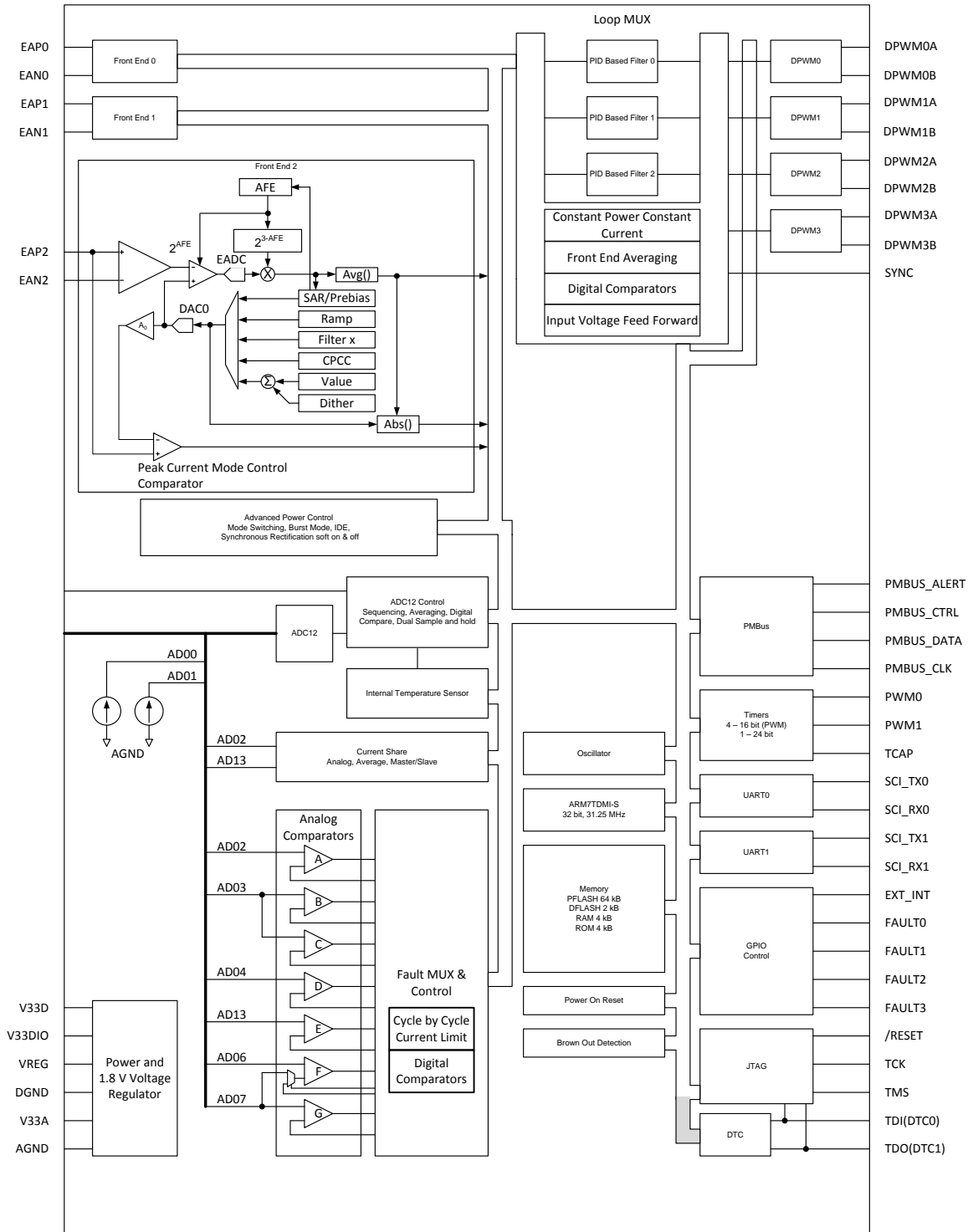

Copyright © 2016, Texas Instruments Incorporated

Figure 1-1. Functional Block Diagram

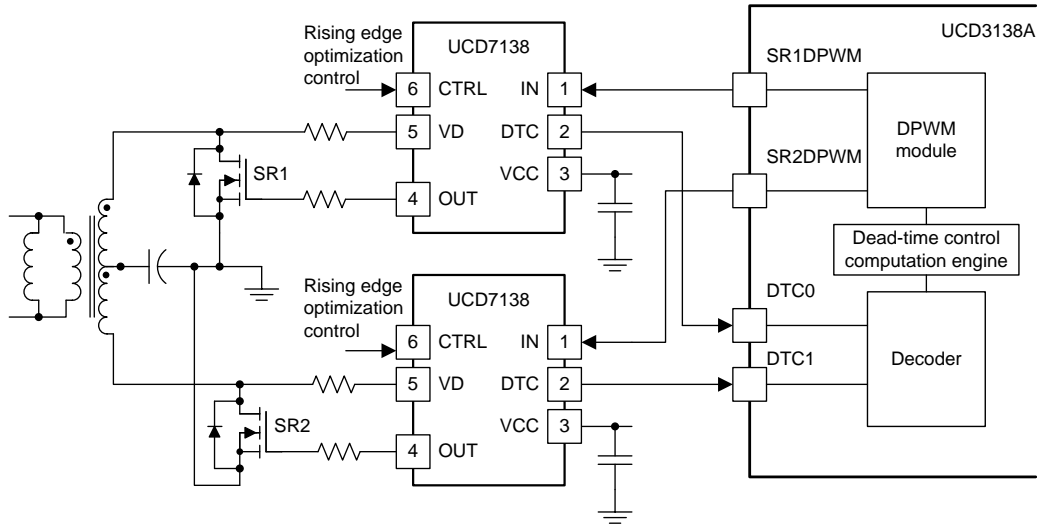

Copyright © 2016, Texas Instruments Incorporated

Figure 1-2. Synchronous Rectifier Peripheral Use with Synchronous Rectifier Driver

Table of Contents

1 Device Overview 1	7.1 Overview 30
1.1 Features 1	7.2 ARM Processor 30
1.2 Applications 2	7.3 Memory 30
1.3 Description 2	7.4 System Module 32
1.4 Functional Block Diagram 3	7.5 Feature Description 34
2 Revision History 6	7.1 Device Functional Modes 51
3 Device Comparison 7	8 Application and Implementation 57
3.1 Product Selection Matrix 7	8.2 Application Information 57
4 Pin Configuration and Functions 8	8.3 Typical Application 58
4.1 UCD3138A RGC Package 8	9 Power Supply Recommendations 69
4.2 UCD3138A RMH Package 10	9.1 Power Supply Decoupling and Bulk Capacitors 69
4.3 UCD3138A RJA Package 12	10 Layout 69
5 Specifications 14	10.1 Layout Guidelines 69
5.1 Absolute Maximum Ratings 14	10.2 Layout Example 70
5.2 ESD Ratings 14	11 Device and Documentation Support 72
5.3 Recommended Operating Conditions 14	11.1 Device Support 72
5.4 Thermal Information 14	11.2 Documentation Support 74
5.5 Electrical Characteristics 15	11.3 Receiving Notification of Documentation Updates .. 74
5.6 PMBus/SMBus/I ² C Timing 19	11.4 Community Resources 74
5.7 Peripherals 20	11.5 Trademarks 74
5.8 Typical Temperature Characteristics 28	11.6 Electrostatic Discharge Caution 74
6 Parametric Measurements Information 29	11.7 Glossary 74
6.1 Power-On Reset (POR) and Brown-Out Reset (BOR) 29	12 Mechanical Packaging and Orderable Information 74
7 Detailed Description 30	12.1 Packaging Information 74

2 Revision History

NOTE: Page numbers for previous revisions may differ from page numbers in the current version.

Changes from Revision D (October 2016) to Revision E		Page
• Added two temperature ranges to the Internal oscillator frequency section.		16
• Added updated V33 slew rate values in the Device Grounding and Layout Guidelines section.		69
• Changed Layout Example images.		70
Changes from Revision C (September 2016) to Revision D		Page
• Added "64-Pin QFN and" to 40-Pin QFN Package bullet.		1
• Deleted ICP9592A T/C Qualification bullet.		1
• Added PACKAGE DRAWING column to the Device Information table.		2
• Changed Note 2 from "Recommended for new 40-pin designs with advance BLR performance" to "Recommended for new 40-pin designs, optimized for improved performance under temperature cycling test for board level reliability (BLR)."		2
• Deleted Note 2, "40-pin 6 x 6 x 0.75 mm ultra-thin QFN with corner anchors optimized for IPC9592A Temperature Cycle Testing. "		2
• Deleted note, "These features help to improve solder-joint reliability".		10
Changes from Revision B (May 2015) to Revision C		Page
• Added the VQFN (40) pin package to the <i>Device Information</i> table.		2
• Added WQFN (40) note, Recommended for new 40-pin designs with advanced BLR performance.		2
• Added the UCD3138A 40 PIN (RJA) column to the <i>Product Selection Matrix</i> table.		7
• Added the <i>UCD3138A RJA Package</i> section.		12
• Added the RJA package to the <i>Thermal Information</i> table.		14
Changes from Revision A (April 2015) to Revision B		Page
• Changed Figure 7-3 image and following notes.		54
Changes from Original (March 2015) to Revision A		Page
• Changed the device status From: Product Preview To: Production.		1
• Changed <i>Feature</i> From: "4KB of Boot ROM Enables Firmware Boot-Load.." To: "Firmware Boot-Load..."		1
• Changed Note 2 of the <i>Device Information</i> table From: "for passing IPC9592A Temperature Cycle Qualification" To: "for IPC9592A Temperature Cycle Testing."		2
• Changed Figure 5-7		26
• Added Figure 6-1		29
• Changed Table 7-4 PRIORITY 19 From: CAPTURE_1_INT To: DTC_FLT_INT.		33
• Changed Figure 7-1 to include DTC Adjustment.		52
• Changed Figure 7-2 to include DTC Adjustment.		53
• Changed Figure 7-3 to include DTC Adjustment.		54

3 Device Comparison

3.1 Product Selection Matrix

FEATURE	UCD3138A 64 PIN (RGC)	UCD3138A 40 PIN (RMH)	UCD3138A 40 PIN (RJA)
ARM7TDMI-S core processor	31.25 MHz	31.25 MHz	31.25 MHz
High resolution DPWM outputs (250-ps resolution)	8	8	8
Number of high speed independent feedback loops (number of regulated output voltages)	3	3	3
12-bit, 267-ksps, general-purpose ADC channels	14	7	7
Digital comparators at ADC outputs	4	4	4
Flash memory (program)	32 kB	32 kB	32 kB
Flash memory (data)	2 kB	2 kB	2 kB
Flash security	√	√	√
RAM	4 kB	4 kB	4 kB
DPWM switching frequency	up to 2 MHz	up to 2 MHz	up to 2 MHz
Programmable fault inputs	4	1 + 2	1 + 2
High speed analog comparators with cycle-by-cycle current limiting	7 ⁽¹⁾	6 ⁽¹⁾	6 ⁽¹⁾
UART (SCI)	2	1	1
PMBus	√	√	√
Timers	4 (16 bit) and 1 (24 bit)	4 (16 bit) and 1 (24 bit)	4 (16 bit) and 1 (24 bit)
Timer PWM outputs	2	1	1
Timer capture inputs	1	1	1
Watchdog	√	√	√
On-chip oscillator	√	√	√
Power-on reset and brown-out reset	√	√	√
Package offering	64 Pin VQFN (9 mm × 9 mm)	40 Pin WQFN (6 mm × 6 mm)	40 Pin WQFN (6 mm × 6 mm)
Sync IN and sync OUT functions	√	√	√
Total GPIO (includes all pins with multiplexed functions such as, DPWM, fault inputs, SCI, and so forth)	30	18	18
External interruptions	1	0	0

(1) To facilitate simple OVP and UVP connections both comparators B and C are connected to the AD03 pin.

4 Pin Configuration and Functions

4.1 UCD3138A RGC Package

64 VQFN Package
Top View

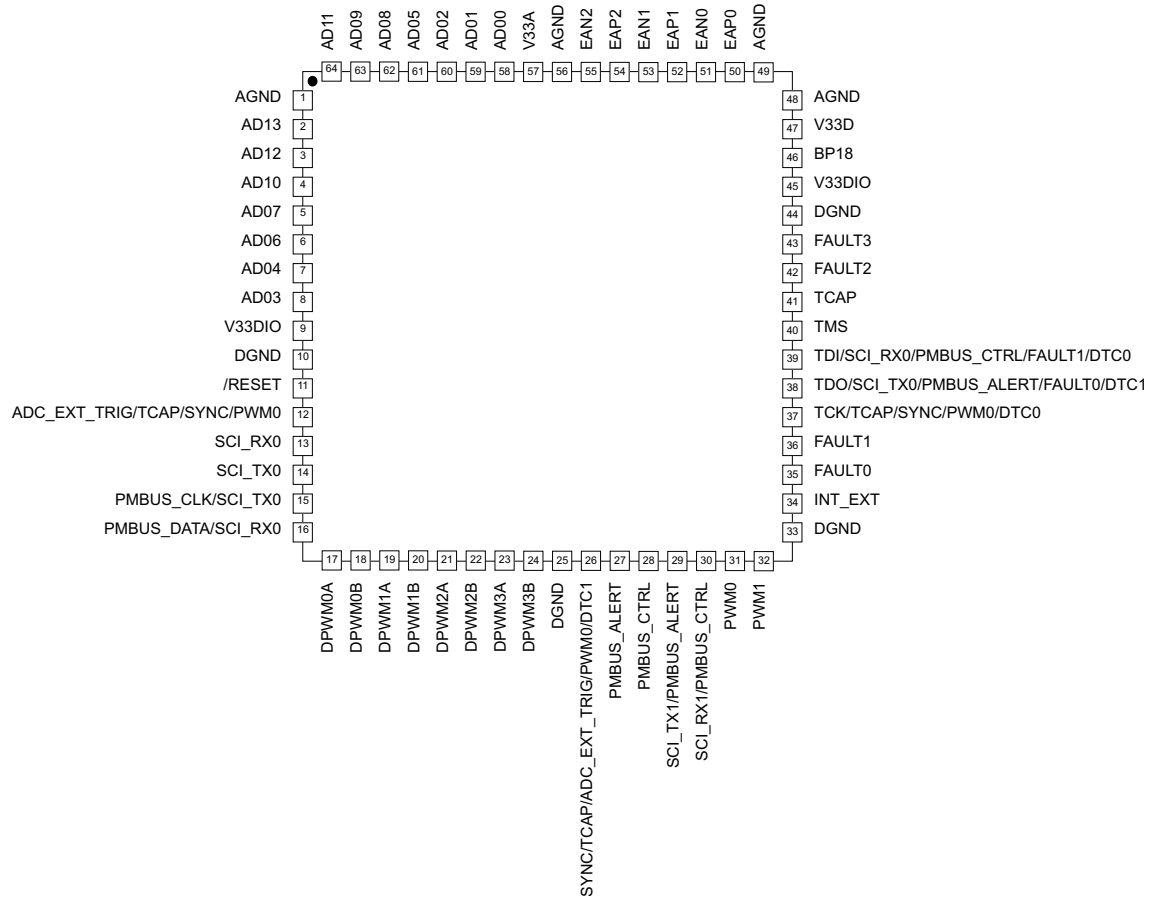

UCD3138A RGC Pin Functions

PIN NO.	NAME	PRIMARY ASSIGNMENT	ALTERNATE ASSIGNMENT				CONFIGURABLE AS A GPIO?
			NO. 1	NO. 2	NO. 3	NO. 4	
1	AGND	Analog ground					
2	AD13	12-bit ADC, Ch 13, comparator E, I-share	DAC output				
3	AD12	12-bit ADC, Ch 12					
4	AD10	12-bit ADC, Ch 10					
5	AD07	12-bit ADC, Ch 7, Connected to comparator F and reference to comparator G	DAC output				
6	AD06	12-bit ADC, Ch 6, Connected to comparator F	DAC output				
7	AD04	12-bit ADC, Ch 4, Connected to comparator D	DAC output				
8	AD03	12-bit ADC, Ch 3, Connected to comparator B and C					
9	V33DIO	Digital I/O 3.3V core supply					
10	DGND	Digital ground					
11	RESET	Device Reset Input, active low					
12	ADC_EXT_TRIG	ADC conversion external trigger input	TCAP	SYNC	PWM0		Yes
13	SCI_RX0	SCI RX 0					Yes
14	SCI_TX0	SCI TX 0					Yes
15	PMBUS_CLK	PMBUS Clock (Open Drain)	SCI TX 0				Yes
16	PMBUS_DATA	PMBus data (Open Drain)	SCI RX 0				Yes
17	DPWM0A	DPWM 0A output					Yes

UCD3138A RGC Pin Functions (continued)

PIN NO.	NAME	PRIMARY ASSIGNMENT	ALTERNATE ASSIGNMENT				CONFIGURABLE AS A GPIO?
			NO. 1	NO. 2	NO. 3	NO. 4	
18	DPWM0B	DPWM 0B output					Yes
19	DPWM1A	DPWM 1A output					Yes
20	DPWM1B	DPWM 1B output					Yes
21	DPWM2A	DPWM 2A output					Yes
22	DPWM2B	DPWM 2B output					Yes
23	DPWM3A	DPWM 3A output					Yes
24	DPWM3B	DPWM 3B output					Yes
25	DGND	Digital ground					
26	SYNC	DPWM Synchronize pin	TCAP	ADC_EXT_TRIG	PWM0	DTC1	Yes
27	PMBUS_ALERT	PMBus Alert (Open Drain)					Yes
28	PMBUS_CTRL	PMBus Control (Open Drain)					Yes
29	SCI_TX1	SCI TX 1	PMBUS_ALERT				Yes
30	SCI_RX1	SCI RX 1	PMBUS_CTRL				Yes
31	PWM0	General purpose PWM 0					Yes
32	PWM1	General purpose PWM 1					Yes
33	DGND	Digital ground					
34	INT_EXT	External Interrupt					Yes
35	FAULT0	External fault input 0					Yes
36	FAULT1	External fault input 1					Yes
37	TCK	JTAG TCK	TCAP	SYNC	PWM0	DTC0	Yes
38	TDO	JTAG TDO	SCL_TX0	PMBUS_ALERT	FAULT0	DTC1	Yes
39	TDI	JTAG TDI	SCL_RX0	PMBUS_CTRL	FAULT1	DTC0	Yes
40	TMS	JTAG TMS					Yes
41	TCAP	Timer capture input					Yes
42	FAULT2	External fault input 2					Yes
43	FAULT3	External fault input 3					Yes
44	DGND	Digital ground					
45	V33DIO	Digital I/O 3.3V core supply					
46	BP18	1.8V Bypass					
47	V33D	Digital 3.3V core supply					
48	AGND	Substrate analog ground					
49	AGND	Analog ground					
50	EAP0	Channel 0, differential analog voltage, positive input					
51	EAN0	Channel 0, differential analog voltage, negative input					
52	EAP1	Channel 1, differential analog voltage, positive input					
53	EAN1	Channel 1, differential analog voltage, negative input					
54	EAP2	Channel 2, differential analog voltage, positive input (Recommended for peak current mode control)					
55	EAN2	Channel #2, differential analog voltage, negative input					
56	AGND	Analog ground					
57	V33A	Analog 3.3-V supply					
58	AD00	12-bit ADC, Ch 0, Connected to current source					
59	AD01	12-bit ADC, Ch 1, Connected to current source					
60	AD02	12-bit ADC, Ch 2, Connected to comparator A, I-share					
61	AD05	12-bit ADC, Ch 5					
62	AD08	12-bit ADC, Ch 8					
63	AD09	12-bit ADC, Ch 9					
64	AD11	12-bit ADC, Ch 11					

4.2 UCD3138A RMH Package

**40 WQFN Package
With Corner Anchors Pin Attributes
Top View**

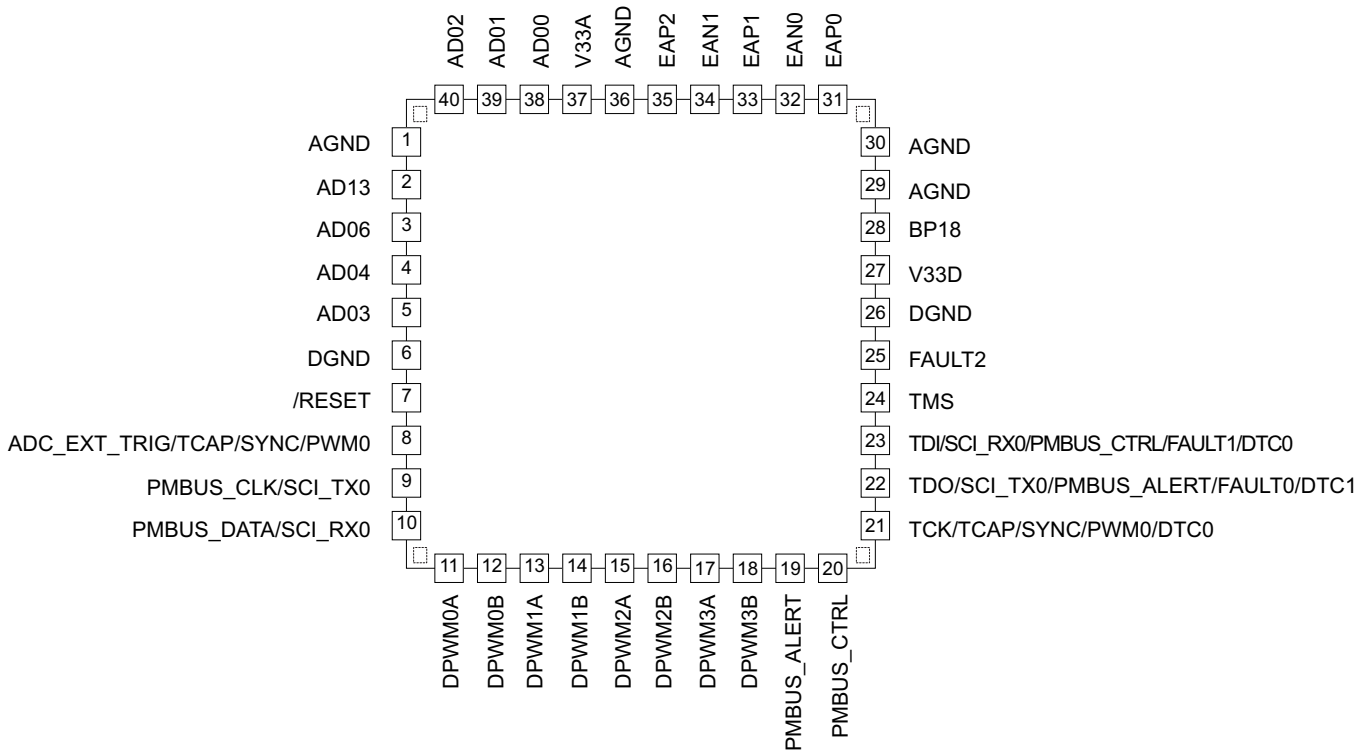

There are four corner pins on the RMH package. The corner anchor pins and thermal pad should be soldered for robust mechanical performance and should be tied to the appropriate ground signal.

UCD3138A RMH Pin Functions

PIN NO.	NAME	PRIMARY ASSIGNMENT	ALTERNATE ASSIGNMENT				CONFIGURABLE AS A GPIO?
			NO. 1	NO. 2	NO. 3	NO. 4	
1	AGND	Analog ground					
2	AD13	12-bit ADC, Ch 13, Connected to comparator E, I-share					
3	AD06	12-bit ADC, Ch 6, Connected to comparator F					
4	AD04	12-bit ADC, Ch 4, Connected to comparator D					
5	AD03	12-bit ADC, Ch 3, Connected to comparator B and C					
6	DGND	Digital ground					
7	$\overline{\text{RESET}}$	Device Reset Input, active low					
8	ADC_EXT_TRIG	ADC conversion external trigger input	TCAP	SYNC	PWM0		Yes
9	PMBUS_CLK	PMBus Clock (Open Drain)	SCI_TX0				Yes
10	PMBUS_DATA	PMBus data (Open Drain)	SCI_RX0				Yes
11	DPWM0A	DPWM 0A output					Yes
12	DPWM0B	DPWM 0B output					Yes
13	DPWM1A	DPWM 1A output					Yes
14	DPWM1B	DPWM 1B output					Yes
15	DPWM2A	DPWM 2A output					Yes
16	DPWM2B	DPWM 2B output					Yes
17	DPWM3A	DPWM 3A output					Yes
18	DPWM3B	DPWM 3B output					Yes
19	PMBUS_ALERT	PMBus Alert (Open Drain)					Yes
20	PMBUS_CTRL	PMBus Control (Open Drain)					Yes
21	TCK	JTAG TCK	TCAP	SYNC	PWM0	DTC0	Yes
22	TDO	JTAG TDO	SCI_TX0	PMBUS_ALERT	FAULT0	DTC1	Yes

UCD3138A RMH Pin Functions (continued)

PIN NO.	NAME	PRIMARY ASSIGNMENT	ALTERNATE ASSIGNMENT				CONFIGURABLE AS A GPIO?
			NO. 1	NO. 2	NO. 3	NO. 4	
23	TDI	JTAG TDI	SCI_RX0	PMBUS_CTRL	FAULT1	DTC0	Yes
24	TMS	JTAG TMS					Yes
25	FAULT2	External fault input 2					Yes
26	DGND	Digital ground					
27	V33D	Digital 3.3V core supply					
28	BP18	1.8V Bypass					
29	AGND	Substrate analog ground					
30	AGND	Analog ground					
31	EAP0	Channel 0, differential analog voltage, positive input					
32	EAN0	Channel 0, differential analog voltage, negative input					
33	EAP1	Channel 1, differential analog voltage, positive input					
34	EAN1	Channel 1, differential analog voltage, negative input					
35	EAP2	Channel 2, differential analog voltage, positive input (Recommended for peak current mode control)					
36	AGND	Analog ground					
37	V33A	Analog 3.3-V supply					
38	AD00	12-bit ADC, Ch 0, Connected to current source					
39	AD01	12-bit ADC, Ch 1, Connected to current source					
40	AD02	12-bit ADC, Ch 2, Connected to comparator A, I-share					
Corner NA	Corner anchor pin	All four anchors should be soldered and tied to GND					

4.3 UCD3138A RJA Package

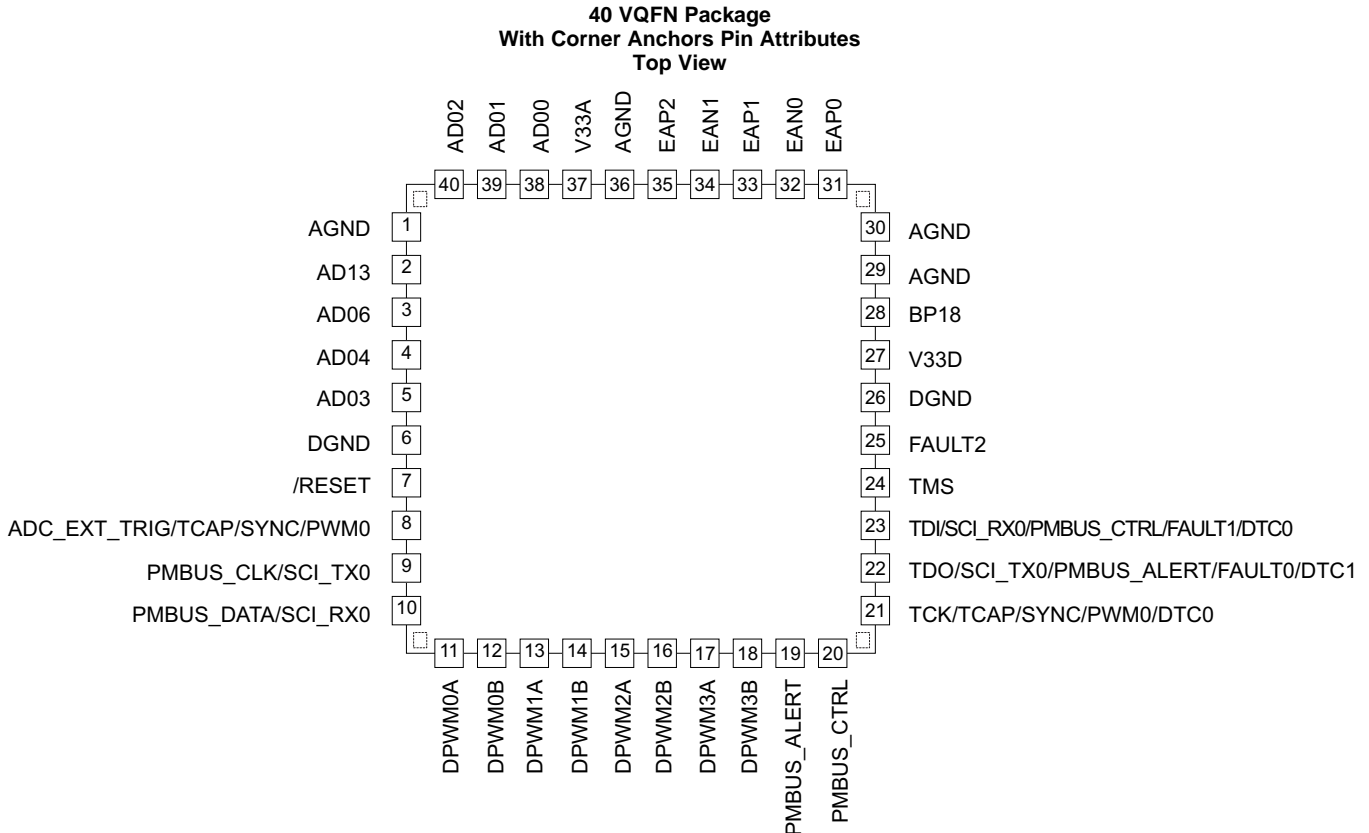

The RJA package has thicker package height compared to the RMH package. There are four corner pins on the RJA package. These features help to improve solder-joint reliability. The corner anchor pins and thermal pad should be soldered for robust mechanical performance and should be tied to the appropriate ground signal.

UCD3138A RJA Pin Functions

PIN NO.	NAME	PRIMARY ASSIGNMENT	ALTERNATE ASSIGNMENT				CONFIGURABLE AS A GPIO?
			NO. 1	NO. 2	NO. 3	NO. 4	
1	AGND	Analog ground					
2	AD13	12-bit ADC, Ch 13, Connected to comparator E, I-share					
3	AD06	12-bit ADC, Ch 6, Connected to comparator F					
4	AD04	12-bit ADC, Ch 4, Connected to comparator D					
5	AD03	12-bit ADC, Ch 3, Connected to comparator B and C					
6	DGND	Digital ground					
7	RESET	Device Reset Input, active low					
8	ADC_EXT_TRIG	ADC conversion external trigger input	TCAP	SYNC	PWM0		Yes
9	PMBUS_CLK	PMBUS Clock (Open Drain)	SCI_TX0				Yes
10	PMBUS_DATA	PMBus data (Open Drain)	SCI_RX0				Yes
11	DPWM0A	DPWM 0A output					Yes
12	DPWM0B	DPWM 0B output					Yes
13	DPWM1A	DPWM 1A output					Yes
14	DPWM1B	DPWM 1B output					Yes
15	DPWM2A	DPWM 2A output					Yes
16	DPWM2B	DPWM 2B output					Yes
17	DPWM3A	DPWM 3A output					Yes
18	DPWM3B	DPWM 3B output					Yes
19	PMBUS_ALERT	PMBus Alert (Open Drain)					Yes
20	PMBUS_CTRL	PMBus Control (Open Drain)					Yes
21	TCK	JTAG TCK	TCAP	SYNC	PWM0	DTC0	Yes

UCD3138A RJA Pin Functions (continued)

PIN NO.	NAME	PRIMARY ASSIGNMENT	ALTERNATE ASSIGNMENT				CONFIGURABLE AS A GPIO?
			NO. 1	NO. 2	NO. 3	NO. 4	
22	TDO	JTAG TDO	SCI_TX0	PMBUS_ALERT	FAULT0	DTC1	Yes
23	TDI	JTAG TDI	SCI_RX0	PMBUS_CTRL	FAULT1	DTC0	Yes
24	TMS	JTAG TMS					Yes
25	FAULT2	External fault input 2					Yes
26	DGND	Digital ground					
27	V33D	Digital 3.3V core supply					
28	BP18	1.8V Bypass					
29	AGND	Substrate analog ground					
30	AGND	Analog ground					
31	EAP0	Channel 0, differential analog voltage, positive input					
32	EAN0	Channel 0, differential analog voltage, negative input					
33	EAP1	Channel 1, differential analog voltage, positive input					
34	EAN1	Channel 1, differential analog voltage, negative input					
35	EAP2	Channel 2, differential analog voltage, positive input (Recommended for peak current mode control)					
36	AGND	Analog ground					
37	V33A	Analog 3.3-V supply					
38	AD00	12-bit ADC, Ch 0, Connected to current source					
39	AD01	12-bit ADC, Ch 1, Connected to current source					
40	AD02	12-bit ADC, Ch 2, Connected to comparator A, I-share					
Corner NA	Corner anchor pin	All four anchors should be soldered and tied to GND					

5 Specifications

5.1 Absolute Maximum Ratings⁽¹⁾

over operating free-air temperature range (unless otherwise noted)

		MIN	MAX	UNIT
Input voltage	V33D to DGND	-0.3	3.8	V
	V33DIO to DGND	-0.3	3.8	V
	V33A to AGND	-0.3	3.8	V
	BP18 to DGND	-0.3	2.5	V
	Ground difference, DGND – AGND		0.3	V
Applied to all pins, excluding AGND ⁽²⁾		-0.3	3.8	V
Junction temperature, T _J		-40	150	°C
Storage temperature, T _{stg}		-55	150	°C

- (1) Stresses beyond those listed under *Absolute Maximum Ratings* may cause permanent damage to the device. These are stress ratings only, and functional operation of the device at these or any other conditions beyond those indicated under *Recommended Operating Conditions* is not implied. Exposure to absolute-maximum-rated conditions for extended periods may affect device reliability.
- (2) Referenced to DGND

5.2 ESD Ratings

			VALUE	UNIT
V _(ESD)	Electrostatic discharge	Human-body model (HBM), per ANSI/ESDA/JEDEC JS-001 ⁽¹⁾	±2000	V
		Charged-device model (CDM), per JEDEC specification JESD22-C101 ⁽²⁾	±500	

- (1) JEDEC document JEP155 states that 500-V HBM allows safe manufacturing with a standard ESD control process.
- (2) JEDEC document JEP157 states that 250-V CDM allows safe manufacturing with a standard ESD control process.

5.3 Recommended Operating Conditions

over operating free-air temperature range (unless otherwise noted)

		MIN	NOM	MAX	UNIT
V _{V33D}	Digital power	3	3.3	3.6	V
V _{V33DIO}	Digital I/O power	3	3.3	3.6	V
V _{V33A}	Analog power	3	3.3	3.6	V
V _{BP18}	1.8-V digital power	1.6	1.8	2	V
T _J	Junction temperature	-40		125	°C

5.4 Thermal Information

THERMAL METRIC ⁽¹⁾		UCD3138A			UNIT
		64 PIN	40 PIN	40 PIN	
		VQFN (RGC)	WQFN (RMH)	VQFN (RJA)	
R _{θJA}	Junction-to-ambient thermal resistance	25.1	31.0	30.1	°C/W
R _{θJC(top)}	Junction-to-case (top) thermal resistance	10.5	16.5	13.5	°C/W
R _{θJB}	Junction-to-board thermal resistance	4.6	6.3	4.9	°C/W
ψ _{JT}	Junction-to-top characterization parameter	0.2	0.2	0.2	°C/W
ψ _{JB}	Junction-to-board characterization parameter	4.6	6.3	4.8	°C/W
R _{θJC(bot)}	Junction-to-case (bottom) thermal resistance	1.2	1.1	0.7	°C/W

- (1) For more information about traditional and new thermal metrics, see the [Semiconductor and IC Package Thermal Metrics](#) application report,

5.5 Electrical Characteristics

3 V ≤ V_{V33A} = V_{V33D} = V_{V33DIO} ≤ to 3.6 V, 1 μF of capacitance from BP18 to DGND, –40°C ≤ T_J ≤ 125°C (unless otherwise noted)

PARAMETER		TEST CONDITION	MIN	TYP	MAX	UNIT
SUPPLY CURRENT						
I _{I33A}	Analog 3.3-V supply current	Measured on V33A. The device is powered up but all ADC12 and EADC sampling is disabled		6.3		mA
I _{I33DIO}	Digital I/O 3.3-V core supply current	All GPIO and communication pins are open		0.35		mA
I _{I33D}	Digital I/O 3.3-V core supply current	ROM program execution		60		mA
		Flash programming in ROM mode			70	mA
I _{I33}	Total supply current	Operating in ROM mode with all DPWMs enabled and switching at 2 MHz. DPWMs all unloaded.			105	mA
ERROR ADC INPUTS EAP, EAN						
EAP – AGND			–0.15		1.998	V
EAP – EAN			–0.256		1.848	V
Typical error range		AFE = 0	–256		248	mV
EAP – EAN Error voltage digital resolution		AFE = 3	0.8	1	1.20	mV
		AFE = 2	1.7	2	2.30	
		AFE = 1	3.55	4	4.45	
		AFE = 0	6.90	8	9.10	
R _{EA}	Input impedance (See Figure 5-3)	AGND reference	0.5			MΩ
I _{OFFSET}	Input offset current (See Figure 5-3)		–5		5	μA
EADC offset		Input voltage = 0 V at AFE = 0	–2		2	LSB
		Input voltage = 0 V at AFE = 1	–2.5		2.5	
		Input voltage = 0 V at AFE = 2	–3		–3	
		Input voltage = 0 V at AFE = 3	–4		4	
Sample rate					16	MHz
Analog front end amplifier bandwidth				100		MHz
A ₀	Gain	See Figure 5-4		1		V/V
	Minimum output voltage				30	mV
EADC DAC						
DAC range			0		1.6	V
VREF DAC reference resolution		10 bit, No dithering enabled		1.56		mV
VREF DAC reference resolution		With 4 bit dithering enabled		97.6		μV
INL			–3.0		3.0	LSB
DNL		Does not include MSB transition	–2.1		1.6	LSB
DNL at MSB transition				–1.4		LSB
DAC reference voltage			1.58		1.61	V
τ	Settling time	From 10% to 90%		250		ns
ADC12						
I _{BIAS}	Bias current for PMBus address pins		9.5		10.5	μA
Measurement range for voltage monitoring			0		2.5	V
Internal ADC reference voltage			2.475	2.500	2.525	V
Change in Internal ADC reference from 25°C reference voltage ⁽¹⁾		–40°C ≤ T _A ≤ 25°C		–1.2		mV
		25°C ≤ T _A ≤ 125°C		–2.6		

(1) Specified by design. Not production tested.

Electrical Characteristics (continued)

3 V ≤ V_{V33A} = V_{V33D} = V_{V33DIO} ≤ 3.6 V, 1 μF of capacitance from BP18 to DGND, –40°C ≤ T_J ≤ 125°C (unless otherwise noted)

PARAMETER	TEST CONDITION	MIN	TYP	MAX	UNIT		
ADC12 INL integral nonlinearity, end point ⁽²⁾ (See Figure 6-1)	ADC_SAMPLINGSEL = 0 to 6 for all ADC12 data	–3.9	±2	4.5	LSB		
ADC12 INL integral nonlinearity, best fit ⁽²⁾ (See Figure 6-1)		–2.3	±1.5	2.6	LSB		
ADC12 DNL differential nonlinearity ⁽²⁾		–0.8/+2.4			LSB		
ADC Zero Scale Error		–7		7	mV		
ADC Full Scale Error		–35		35	mV		
Input bias	V _{ADC12} = 2.5 V			400	nA		
Input leakage resistance ⁽¹⁾	ADC_SAMPLINGSEL = 0 or ADC_SAMPLINGSEL = 6		1		MΩ		
Input Capacitance ⁽¹⁾			10		pF		
ADC single sample conversion time ⁽¹⁾	ADC_SAMPLINGSEL = 0 or ADC_SAMPLINGSEL = 6		3.9		μs		
DIGITAL INPUTS/OUTPUTS⁽³⁾⁽⁴⁾							
V _{OL}	Low-level output voltage ⁽⁵⁾	I _{OH} = 4 mA, V _{V33DIO} = 3 V		DGND + 0.25	V		
V _{OH}	High-level output voltage ⁽⁵⁾	I _{OH} = –4 mA, V _{V33DIO} = 3 V		V33DIO – 0.6	V		
V _{IH}	High-level input voltage	V _{V33DIO} = 3 V		2.1	V		
V _{IL}	Low-level input voltage	V _{V33DIO} = 3 V		1.1	V		
I _{OH}	Output sinking current			4	mA		
I _{OL}	Output sourcing current	–4			mA		
SYSTEM PERFORMANCE							
TWD	Watchdog time out range	Total time is: TWD × (WDCTRL.PERIOD + 1)		14.6	17	20.5	ms
	Time to disable DPWM output based on active FAULT pin signal	High level on FAULT pin			70		ns
	Processor master clock (MCLK)				31.25		MHz
t _{Delay}	Digital compensator delay ⁽⁶⁾	(1 clock = 32 ns)				6	clocks
t _(reset)	Pulse width needed at reset ⁽¹⁾			10			μs
	Retention period of flash content (data retention and program)	T _J = 25°C		100			years
	Program time to erase one page or block in data flash or program flash				20		ms
	Program time to write one word in data flash or program flash				20		μs
f _(PCLK)	Internal oscillator frequency	–40°C to +125°C		240	250	260	MHz
		–5°C to +85°C		245	250	255	MHz
	Sync-in or sync-out pulse width	SYNC pin			256		ns
	Flash read				1		MCLKs
	Flash rrite				20		μs
I _{SHARE}	Current share current source (See Figure 7-16)			238		259	μA

(2) Minimum and maximum values are specified by design and characterization data.

(3) DPWM outputs are low after reset. Other GPIO pins are configured as inputs after reset.

(4) On the 40-pin package V33DIO is connected to V33D internally.

(5) The maximum total current, I_{OH(max)} and I_{OL(max)} for all outputs combined, should not exceed 12 mA to hold the maximum voltage drop specified. Maximum sink current per pin = –6 mA at V_{OL}; maximum source current per pin = 6 mA at V_{OH}.

(6) Time from close of error ADC sample window to time when digitally calculated control effort (duty cycle) is available. This delay, which has no variation associated with it, must be accounted for when calculating the system dynamic response.

Electrical Characteristics (continued)

$3\text{ V} \leq V_{V33A} = V_{V33D} = V_{V33DIO} \leq 3.6\text{ V}$, 1 μF of capacitance from BP18 to DGND, $-40^\circ\text{C} \leq T_J \leq 125^\circ\text{C}$ (unless otherwise noted)

PARAMETER		TEST CONDITION	MIN	TYP	MAX	UNIT
R _{SHARE}	Current share resistor (See Figure 7-16)		9.75		10.3	k Ω

Electrical Characteristics (continued)

$3\text{ V} \leq V_{V33A} = V_{V33D} = V_{V33DIO} \leq 3.6\text{ V}$, $1\text{ }\mu\text{F}$ of capacitance from BP18 to DGND, $-40^\circ\text{C} \leq T_J \leq 125^\circ\text{C}$ (unless otherwise noted)

PARAMETER		TEST CONDITION	MIN	TYP	MAX	UNIT
POWER ON RESET AND BROWN OUT (V33D pin, See Figure 6-2)						
V _{GH}	Voltage good high			2.7		V
V _{GL}	Voltage good low			2.5		V
V _{res}	Voltage at which I_{RESET} signal is valid			0.8		V
t _{POR}	Time delay after power is good or RESET relinquished			1		ms
	Brownout	Internal signal warning of brownout conditions		2.9		V
TEMPERATURE SENSOR⁽⁷⁾						
V _{TEMP}		Voltage range of sensor	1.46		2.44	V
	Voltage resolution	V/°C		5.9		mV/°C
	Temperature resolution	°C per bit		0.1034		°C/LSB
	Accuracy ⁽⁷⁾⁽⁸⁾		-10	±5	10	°C
	Temperature range		-40		125	°C
I _{TEMP}	Current draw of sensor when active			30		μA
t _{ON}	Turn on time, settling time of sensor			100		μs
V _{AMB}	Ambient temperature	Trimmed 25°C reading		1.85		V
ANALOG COMPARATOR						
DAC	Reference DAC range		0		2.5	V
	Reference voltage		2.478	2.5	2.513	V
	Bits			7		bits
	INL ⁽⁷⁾		-0.42		0.21	LSB
	DNL ⁽⁷⁾		0.06		0.12	LSB
	Offset		-5.5		19.5	mV
	Time to disable DPWM output based on 0 V to 2.5 V step input on the analog comparator. ⁽¹⁾				150	ns
	Reference DAC buffered output load ⁽⁹⁾		0.5		1	mA
	Buffer offset (-0.5 mA)	$0.3\text{ V} < V_{\text{DAC}} < 2.17\text{ V}$	0		10	mV
	Buffer offset (1.0 mA)	$0.3\text{ V} < V_{\text{DAC}} < 2.17\text{ V}$	-10		0	mV

(7) Specified by design. Not production tested.

(8) Ambient temperature offset value should be used from the TEMPSENCTRL register to meet accuracy.

(9) Available from reference DACs for comparators D, E, F, and G.

5.6 PMBus/SMBus/I²C Timing

The timing characteristics and timing diagram for the communications interface that supports I²C, SMBus, and PMBus in Slave or Master mode are shown in Section 5.6, Figure 5-1, and Figure 5-2. The values in Section 5.6 describe device functional during 400 kHz operating frequency. However, the device supports all three speeds, standard (100 kHz), fast (400 kHz).

Typical values at T_A = 25°C and VCC = 3.3 V (unless otherwise noted)

PARAMETER	TEST CONDITIONS	MIN	TYP	MAX	UNIT
f _{SMB}	SMBus/PMBus operating frequency		100	400	kHz
f _{I2C}	I ² C operating frequency		100	400	kHz
t _(BUF)	Bus free time between start and stop ⁽¹⁾		1.3		µs
t _(HD:STA)	Hold time after (repeated) start ⁽¹⁾		0.6		µs
t _(SU:STA)	Repeated start setup time ⁽¹⁾		0.6		µs
t _(SU:STO)	Stop setup time ⁽¹⁾		0.6		µs
t _(HD:DAT)	Data hold time	Receive mode	0		ns
t _(SU:DAT)	Data setup time		100		ns
t _(TIMEOUT)	Error signal/detect ⁽²⁾			35	ms
t _(LOW)	Clock low period		1.3		µs
t _(HIGH)	Clock high period ⁽³⁾		0.6		µs
t _(LOW:SEXT)	Cumulative clock low slave extend time ⁽⁴⁾			25	ms
t _f	Clock/data fall time	Rise time t _r = (V _{ILmax} - 0.15) to (V _{IHmin} + 0.15)		300	ns
t _r	Clock/data rise time	Fall time t _f = 0.9 VDD to (V _{ILmax} - 0.15)		300	ns
C _b	Total capacitance of one bus line			400	pF

- (1) Fast mode, 400 kHz
- (2) The device times out when any clock low exceeds t_(TIMEOUT).
- (3) t_(HIGH), Max, is the minimum bus idle time. SMBC = SMBD = 1 for t > 50 ms causes reset of any transaction that is in progress. This specification is valid when the NC_SMB control bit remains in the default cleared state (CLK[0] = 0).
- (4) t_(LOW:SEXT) is the cumulative time a slave device is allowed to extend the clock cycles in one message from initial start to the stop.
- (5) C_b (pF)

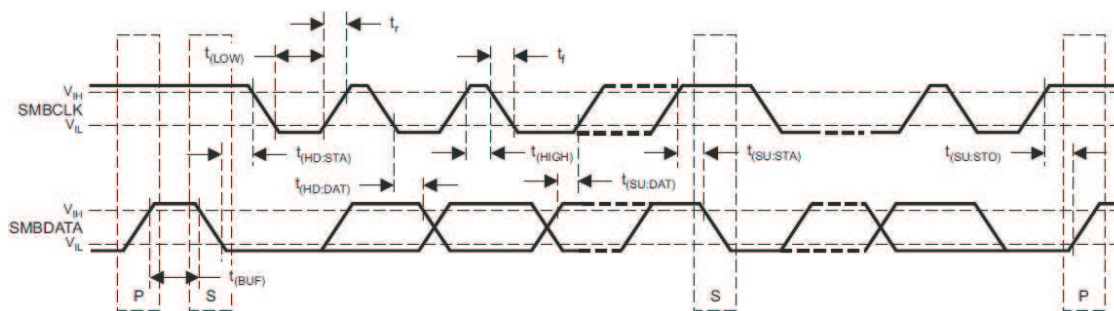

Figure 5-1. I²C/SMBus/PMBus Timing Diagram

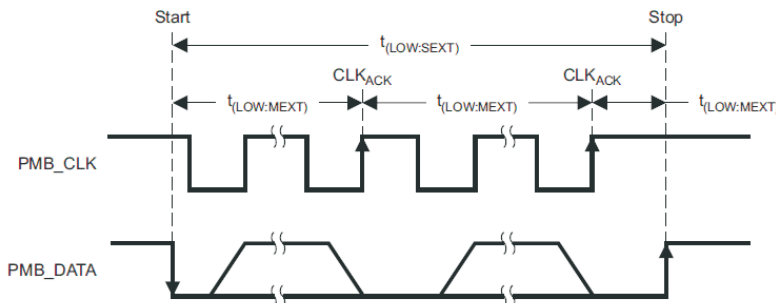

Figure 5-2. Bus Timing in Extended Mode

5.7 Peripherals

5.7.1 Digital Power Peripherals (DPPs)

At the core of the UCD3138A controller are three DPPs. Each DPP can be configured to drive from one to eight DPWM outputs. Each DPP consists of:

- Differential input error ADC (EADC) with sophisticated controls
- Hardware accelerated digital 2-pole/2-zero PID based compensator
- Digital PWM module with support for a variety of topologies

These can be connected in many different combinations, with multiple filters and DPWMs. They are capable of supporting functions like input voltage feed forward, current mode control, and constant current/constant power, and so on. The simplest configuration is shown in the following figure:



5.7.1.1 Front End

Figure 5-3 shows the block diagram of the front end module. It consists of a differential amplifier, an adjustable gain error amplifier, a high speed flash analog-to-digital converter (EADC), digital averaging filters and a precision high resolution set point DAC reference. The programmable gain amplifier in concert with the EADC and the adjustable digital gain on the EADC output work together to provide 9 bits of range with 6 bits of resolution on the EADC output. The output of the Front End module is a 9-bit sign extended result with a gain of 1 LSB / mV. Depending on the value of AFE selected, the resolution of this output could be either 1, 2, 4 or 8 LSBs. In addition each EADC has the ability to automatically select the AFE value such that the minimum resolution is maintained that still allows the voltage to fit within the range of the measurement. The EADC control logic receives the sample request from the DPWM module for initiating an EADC conversion. EADC control circuitry captures the EADC-9-bit-code and strobes the digital compensator for processing of the representative error. The set point DAC has 10 bits with an additional 4 bits of dithering resulting in an effective resolution of 14 bits. This DAC can be driven from a variety of sources to facilitate things like soft start, nested loops, and so on. Some additional features include the ability to change the polarity of the error measurement and an absolute value mode which automatically adds the DAC value to the error.

It is possible to operate the controller in a peak current mode control configuration; an EADC is recommended for implementing peak current mode control. In this mode, topologies like a phase shifted full bridge converter can be controlled to maintain transformer flux balance. The internal DAC can be ramped at a synchronously controlled slew rate to achieve a programmable slope compensation. This eliminates the sub-harmonic oscillation as well as improves input voltage feed-forward performance. A0 is a unity gain buffer used to isolate the peak current mode comparator. The offset of this buffer is specified in [Section 5.5](#).

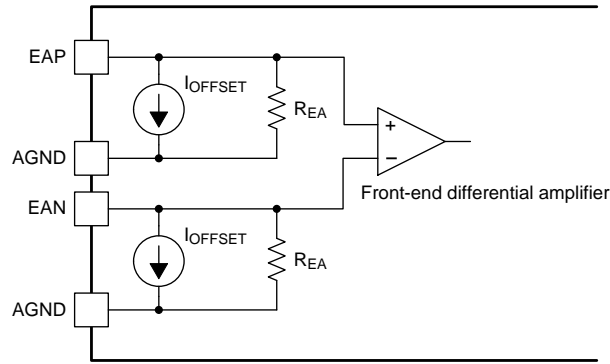

Figure 5-3. Input Stage of EADC Module

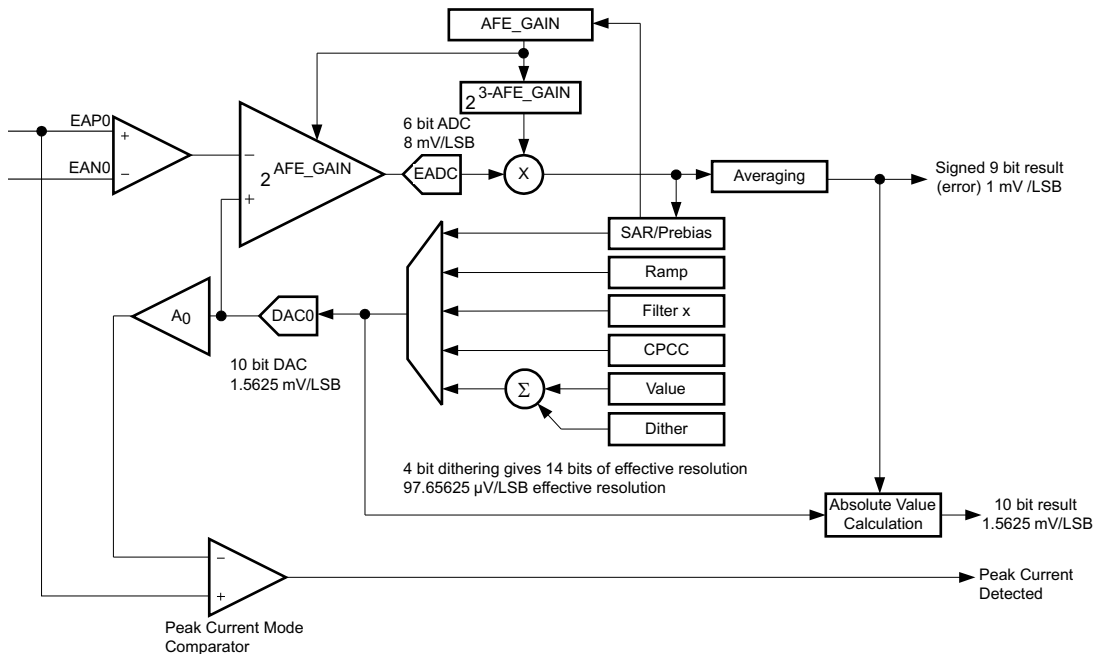

Figure 5-4. Front End Module
(Front End 2 Recommended for Peak Current Mode Control)

5.7.1.2 DPWM Module

The DPWM module represents one complete DPWM channel with 2 independent outputs, A and B. Multiple DPWM modules within the UCD3138A system can be configured to support all key power topologies. DPWM modules can be used as independent DPWM outputs, each controlling one power supply output voltage rail. It can also be used as a synchronized DPWM—with user selectable phase shift between the DPWM channels to control power supply outputs with multiphase or interleaved DPWM configurations.

The output of the filter feeds the high resolution DPWM module. The DPWM module produces the pulse width modulated outputs for the power stage switches. The compensator calculates the duty ratio as a 24-bit number in Q23 fixed point format (23 bit integer with 1 sign bit). This represents a value within the range 0.0 to 1.0. This duty ratio value is used to generate the corresponding DPWM output ON time. The resolution of the DPWM ON time is 250 psec.

Each DPWM module can be synchronized to another module or to an external sync signal. An input SYNC signal causes a DPWM ramp timer to reset. The SYNC signal outputs—from each of the four DPWM modules—occur when the ramp timer crosses a programmed threshold. In this way the phase of the DPWM outputs for multiple power stages can be tightly controlled.

The DPWM logic is probably the most complex of the Digital Peripherals. It receives the output of the compensator and converts it into the correct DPWM output for several power supply topologies. It provides for programmable dead times and cycle adjustments for current balancing between phases. It controls the triggering of the EADC. It can synchronize to other DPWMs or to external sources. It can provide synchronization information to other DPWMs or to external recipients. In addition, it interfaces to several fault handling circuits. Some of the control for these fault handling circuits is in the DPWM registers. Fault handling is covered in the Fault Mux section.

Each DPWM module supports the following features:

- Dedicated 14 bit time-base with period and frequency control
- Shadow period register for end of period updates.
- Quad-event control registers (A and B, rising and falling) (Events 1 to 4)
 - Used for on/off DPWM duty ratio updates.
- Phase control relative to other DPWM modules
- Sample trigger placement for output voltage sensing at any point during the DPWM cycle.
- Support for two independent edge placement DPWM outputs (same frequency or period setting)
- Dead-time between DPWM A and B outputs
- High Resolution capabilities – 250 ps
- Pulse cycle adjustment of up to $\pm 8.192 \mu\text{s}$ ($32768 \times 250 \text{ ps}$)
- Active high/ active low output polarity selection
- Provides events to trigger both CPU interruptions and start of ADC12 conversions.

5.7.1.3 DPWM Events

Each DPWM can control the following timing events:

1. *Sample Trigger Count*—This register defines where the error voltage is sampled by the EADC in relationship to the DPWM period. The programmed value set in the register should be one fourth of the value calculated based on the DPWM clock. The clock controlling the circuitry runs at one fourth of the DPWM clock (PCLK = 250 MHz max). When this sample trigger count is equal to the DPWM Counter, it initiates a front end calculation by triggering the EADC, resulting in a CLA calculation, and a DPWM update. Oversampling can be set for 2, 4, or 8 times the sampling rate.
2. *Phase Trigger Count* – count offset for slaving another DPWM (Multi-Phase/Interleaved operation).
3. *Period* – low resolution switching period count. (count of PCLK cycles)
4. *Event 1* – count offset for rising DPWM A event. (PCLK cycles)
5. *Event 2* – DPWM count for falling DPWM A event that sets the duty ratio. Last 4 bits of the register are for high resolution control. Upper 14 bits are the number of PCLK cycle counts.
6. *Event 3* – DPWM count for rising DPWM B event. Last 4 bits of the register are for high resolution control. Upper 14 bits are the number of PCLK cycle counts.
7. *Event 4* – DPWM count for falling DPWM B event. Last 4 bits of the register are for high resolution control. Upper 14 bits are the number of PCLK cycle counts.
8. *Cycle Adjust* – Constant offset for Event 2 and Event 4 adjustments.

Basic comparisons between the programmed registers and the DPWM counter can create the desired edge placements in the DPWM. High resolution edge capability is available on Events 2, 3, and 4.

Figure 5-5 is for multi-mode, open loop. Open loop means that the DPWM is controlled entirely by its own registers, not by the filter output. In other words, the power supply control loop is not closed.

The Sample Trigger signals are used to trigger the front end to sample input signals. The Blanking signals are used to blank fault measurements during noisy events, such as FET turn on and turn off.

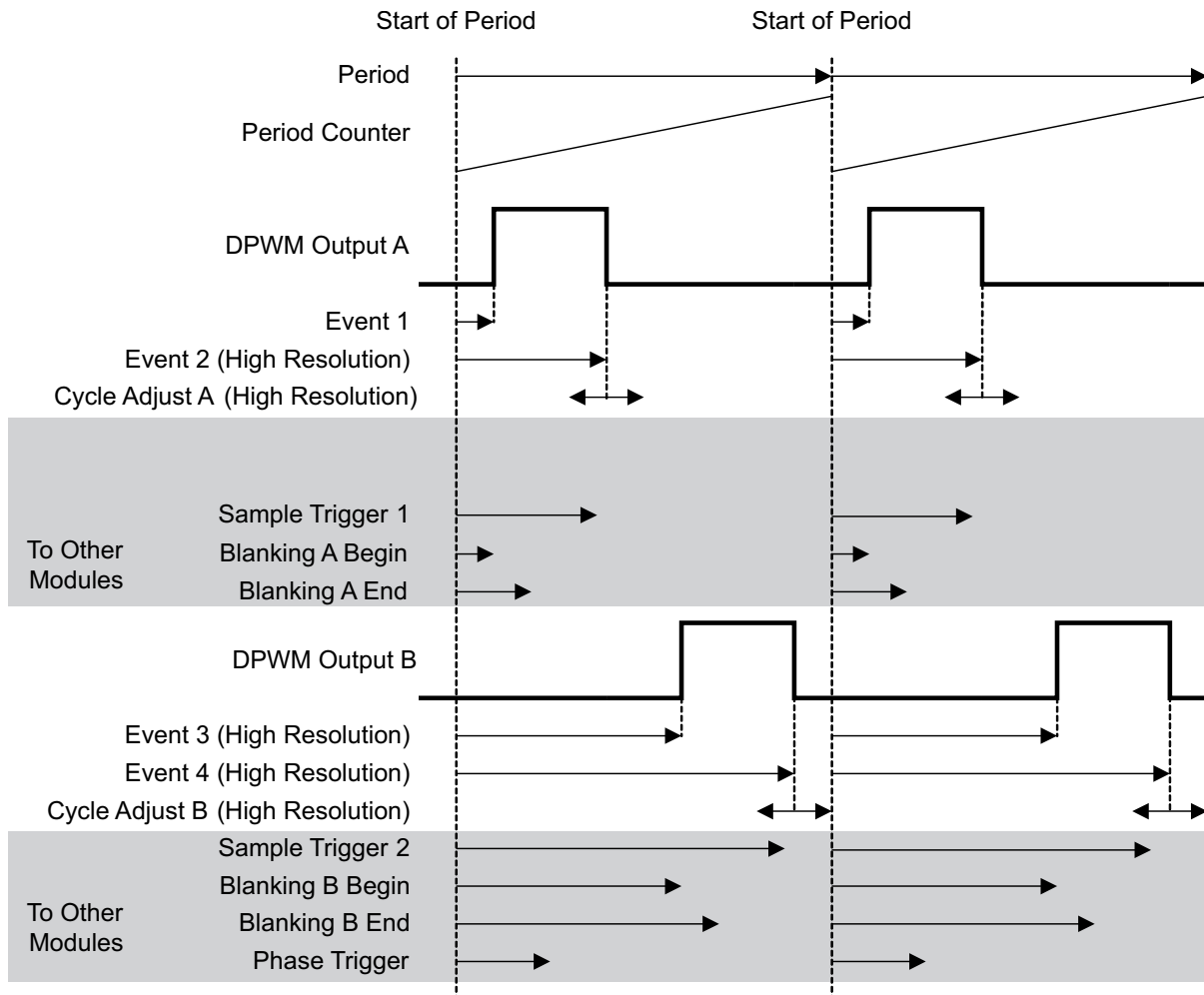

Events which change with DPWM mode:

- DPWM A Rising Edge = Event 1
- DPWM A Falling Edge = Event 2 + Cycle Adjust A
- DPWM B Rising Edge = Event 3
- DPWM B Falling Edge = Event 4 + Cycle Adjust B
- Phase Trigger = Phase Trigger Register value or Filter Duty

Events always set by their registers, regardless of mode:

- Sample Trigger 1, Sample Trigger 2, Blanking A Begin, Blanking A End, Blanking B Begin, Blanking B End

Figure 5-5. Multi Mode Open Loop

5.7.1.4 High Resolution DPWM

Unlike conventional PWM controllers where the frequency of the clock dictates the maximum resolution of PWM edges, the UCD3138A DPWM can generate waveforms with resolutions as small as 250 ps. This is 16x the resolution of the clock driving the DPWM module.

This is achieved by providing the DPWM mechanism with 16 phase shifted clock signals of 250 MHz. The high resolution section of DPWM can be enabled or disabled, and the resolution can be defined in several steps between 4 ns to 250 ps. This is done by setting the values of PWM_HR_MULTI_OUT_EN and HIRES_SCALE inside the DPWM Control register 1. See the Power Peripherals programmer's manual for details.

5.7.1.5 Oversampling

The DPWM module has the capability to trigger an oversampling event by initiating the EADC to sample the error voltage. The default 00 configuration has the DPWM trigger the EADC once based on the sample trigger register value. The over sampling register has the ability to trigger the sampling 2, 4 or 8 times per PWM period. Thus the time the over sample happens is at the divide by 2, 4, or 8 time set in the sampling register. The 01 setting triggers 2X oversampling, the 10 setting triggers 4X over sampling, and the 11 triggers oversampling at 8X.

5.7.1.6 DPWM Interrupt Generation

The DPWM has the capability to generate a CPU interrupt based on the PWM frequency programmed in the period register. The interrupt can be scaled by a divider ratio of up to 255 for developing a slower interrupt service execution loop. This interrupt can be fed to the ADC circuitry for providing an ADC12 trigger for sequence synchronization. [Table 5-1](#) outlines the divide ratios that can be programmed.

5.7.1.7 DPWM Interrupt Scaling/Range

Table 5-1. DPWM Interrupt Divide Ratio

Interrupt Divide Setting	Interrupt Divide Count	Interrupt Divide Count (hex)	Switching Period Frames (Assume 1-MHz Loop)	Number of 32-MHz Processor Cycles
1	0	00	1	32
2	1	01	2	64
3	3	03	4	128
4	7	07	8	256
5	15	0F	16	512
6	31	1F	32	1024
7	47	2F	48	1536
8	63	3F	64	2048
9	79	4F	80	2560
10	95	5F	96	3072
11	127	7F	128	4096
12	159	9F	160	5120
13	191	BF	192	6144
14	223	DF	224	7168
15	255	FF	256	8192

5.7.1.8 DPWM Synchronization

This section describes the register settings and hardware considerations necessary to modulate the DPWM pins with PCMC and internal slope compensation.

DPWM1 is synchronized to DPWM0, DPWM2 is synchronized to DPWM1, and DPWM3 is synchronized to DPWM2, ½ period out of phase using these commands:

```
Dpwm1Regs.DPWMCTRL0.bit.MSYNC_SLAVE_EN = 1; //configured to slave
Dpwm2Regs.DPWMCTRL0.bit.MSYNC_SLAVE_EN = 1; // configured to slave
Dpwm3Regs.DPWMCTRL0.bit.MSYNC_SLAVE_EN = 1; // configured to slave
```

```
Dpwm0Regs.DPWMPHASETRIG.all = PWM_SLAVESYNC;
Dpwm1Regs.DPWMPHASETRIG.all = PWM_SLAVESYNC;
Dpwm2Regs.DPWMPHASETRIG.all = PWM_SLAVESYNC;
```

```
LoopMuxRegs.DPWMMUX.bit.DPWM1_SYNC_SEL // Slave to dpwm-0
= 0; // Slave to dpwm-1
LoopMuxRegs.DPWMMUX.bit.DPWM2_SYNC_SEL // Slave to dpwm-2
= 1;
LoopMuxRegs.DPWMMUX.bit.DPWM3_SYNC_SEL
= 2;
```

If the event registers on the DPWMs are the same, the two pairs of signals are symmetrical. All code examples are taken from the PSFB EVM code, unless otherwise stated.

5.7.1.9 Synchronous Rectifier Dead-Time Optimization Peripheral

The UCD3138A has an advanced dead time control interface where it can accept output signals from the UCD7138 device and optimize SR gate driver signals accordingly. The UCD7138 low-side MOSFET driver is a high-performance driver for secondary-side synchronous rectification (SR) with body diode conduction sensing. The device is suitable for high power high efficiency isolated converter applications where dead-time optimization is desired. The UCD7138 gate driver is a companion device to the UCD3138A highly-integrated digital controller for isolated power.

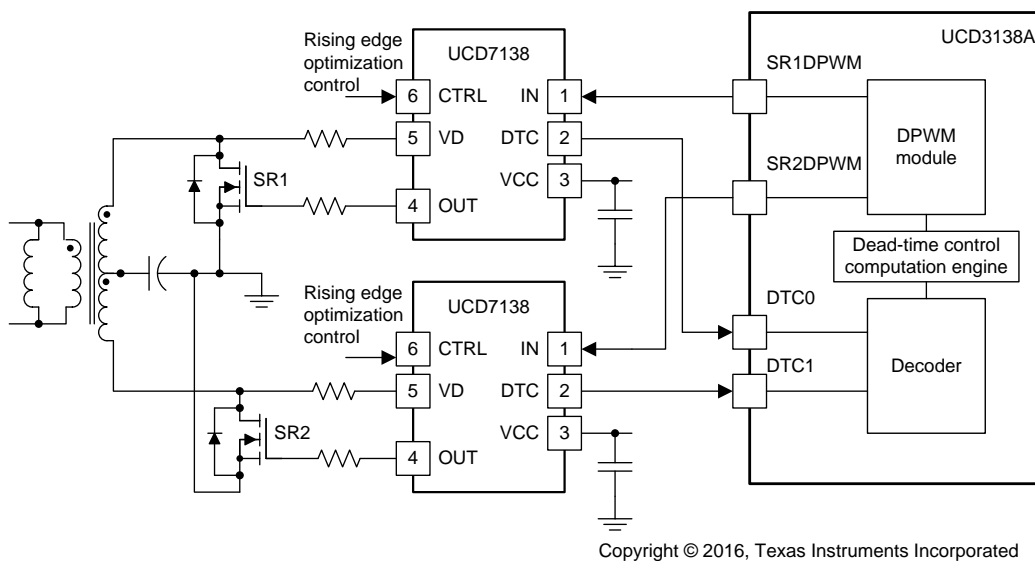

Copyright © 2016, Texas Instruments Incorporated

Figure 5-6. Synchronous Rectifier Peripheral use with Synchronous Rectifier Driver

DTC0 and DTC1 are received body diode conduction inputs from UCD7138. SR0_DPWM and SR1_DPWM are the DPWM waveforms for the SRs. The red and green edges are moving edges controlled by both the filter output and the DTC interface. In each cycle, right after the falling edge of the SR DPWM waveform, a body diode conduction time detection window is generated. The detection window is defined by both DETECT_BLANK and DETECT_LEN registers. During this detection window, a 4-ns timer capture counts how long the body diode conducts. Then the DPWM turn off edge of the next cycle is adjusted accordingly.

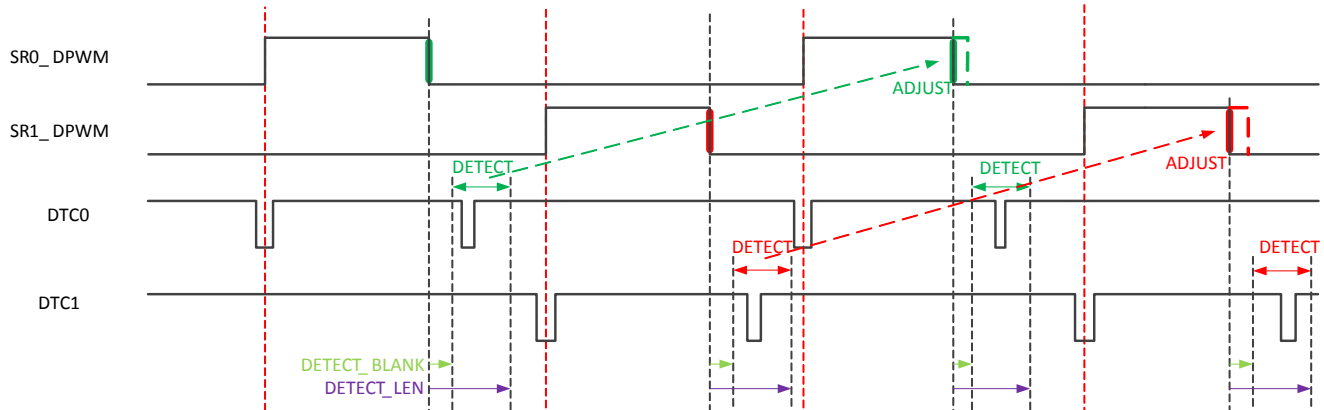

Figure 5-7. Timing Diagram of the DTC Interface

Figure 5-8 shows how the turn off edge is adjusted based on the DTC measurement of the previous cycle. The A_ADJ and B_ADJ registers in DTCMONITOR are signed accumulators; default value is 0.

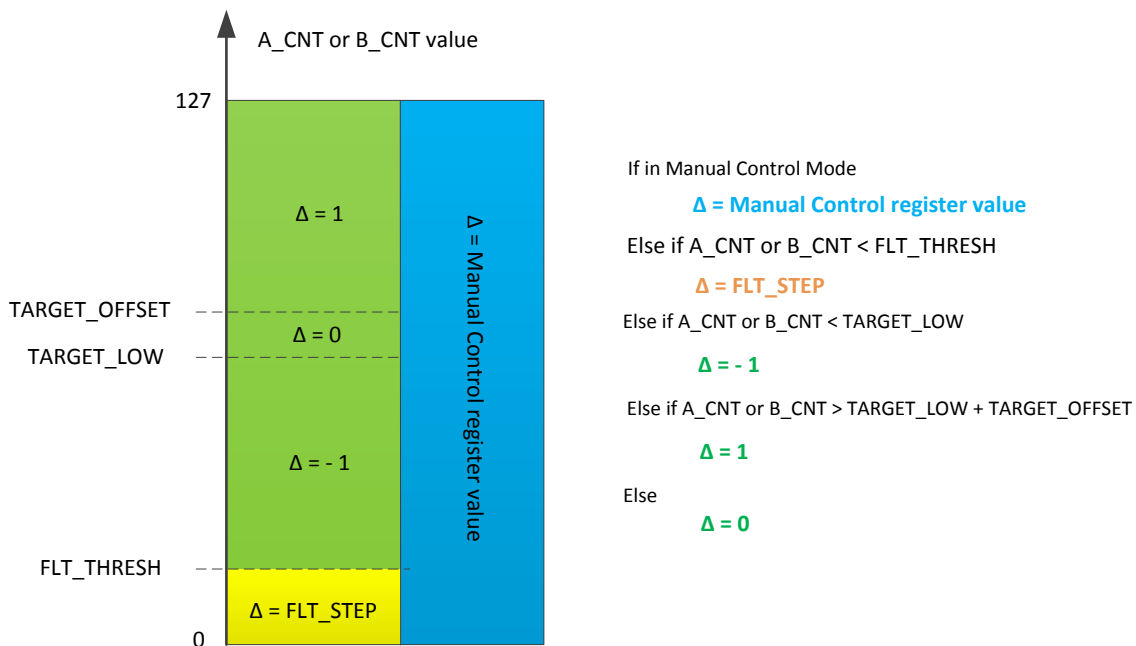

Figure 5-8. DTC Interface Principle

Based on the DTC measured, in the next cycle:

- $A_ADJ = A_ADJ + A_Δ$
- $A_ADJ = A_ADJ + B_Δ$

In each cycle, the A_ADJ and B_ADJ accumulator values are dynamically adjust the dead time. The Δ value changes after the measured body diode conduction time. A_ADJ and B_ADJ have been measured and compared to the threshold values in automatic control mode. A_ADJ and B_ADJ can be controlled by firmware while in manual control mode.

Other figures of this peripheral include negative current fault protection, consecutive fault counter, DTC input multiplexor, etc. For details, refer to the programmer's manual.

5.8 Typical Temperature Characteristics

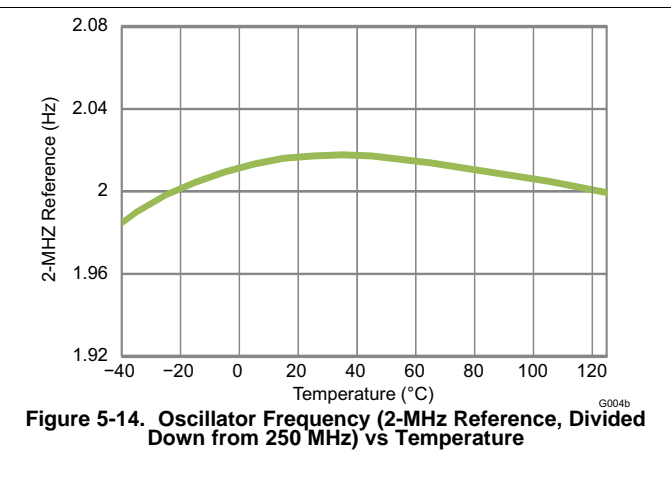
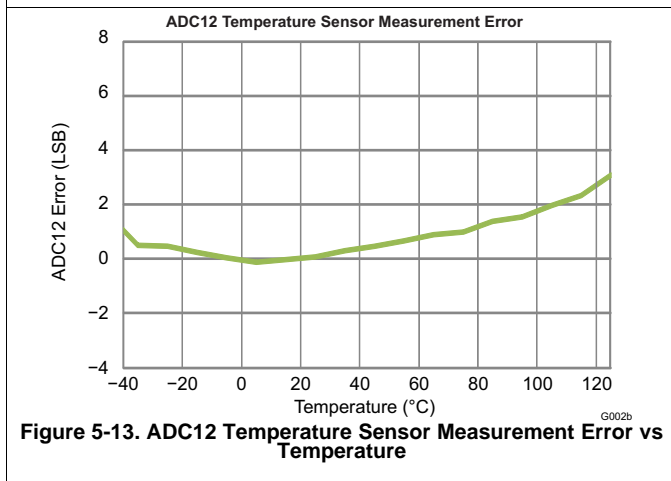
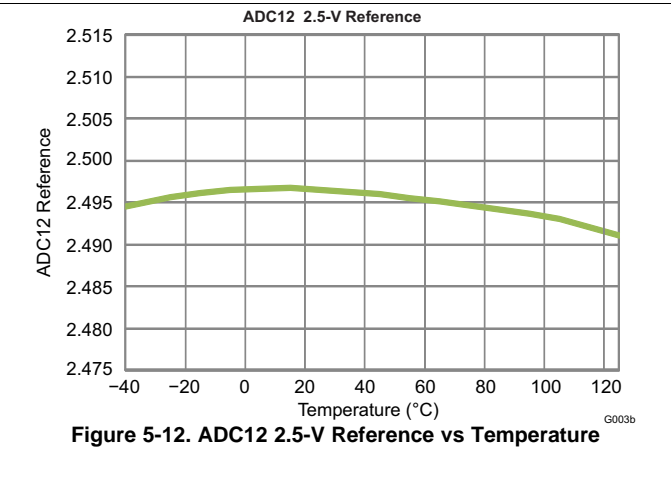
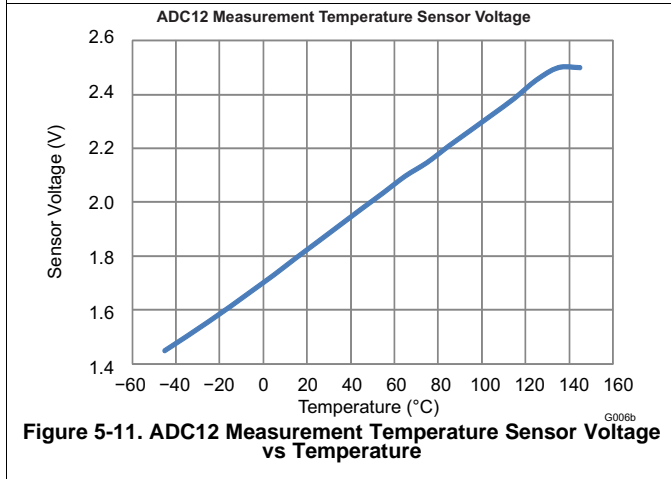
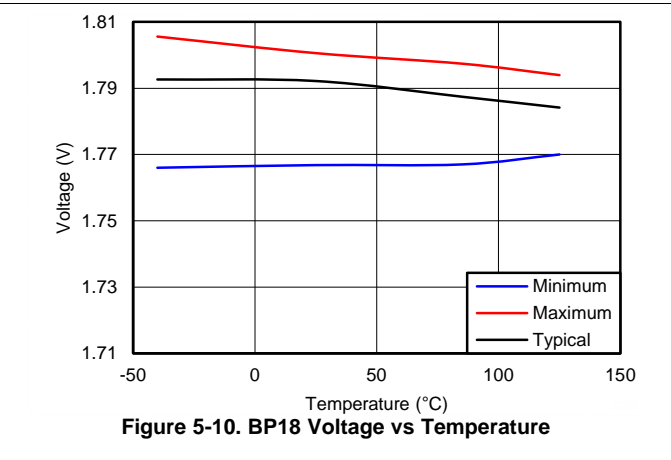
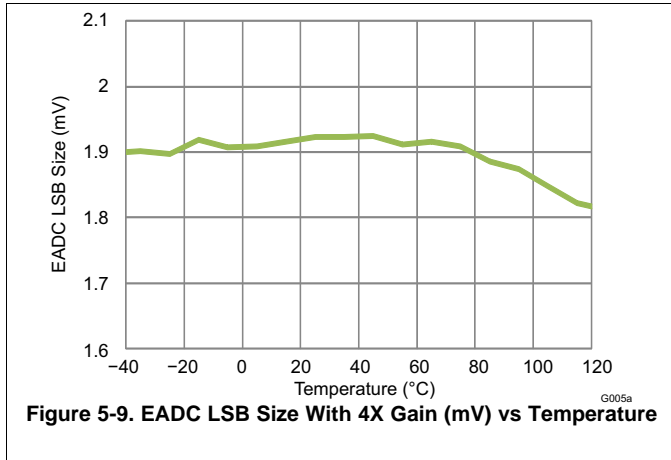

6 Parametric Measurements Information

6.1 Power-On Reset (POR) and Brown-Out Reset (BOR)

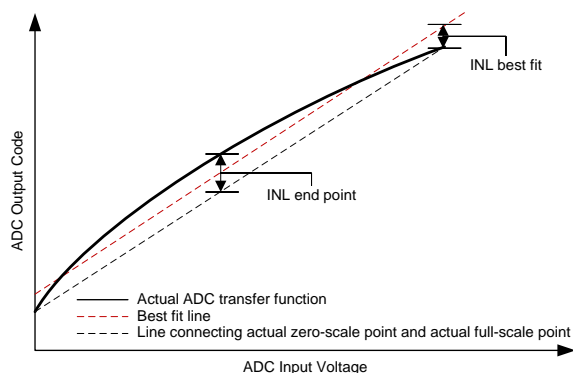

Figure 6-1. Best Fit INL and End Point INL

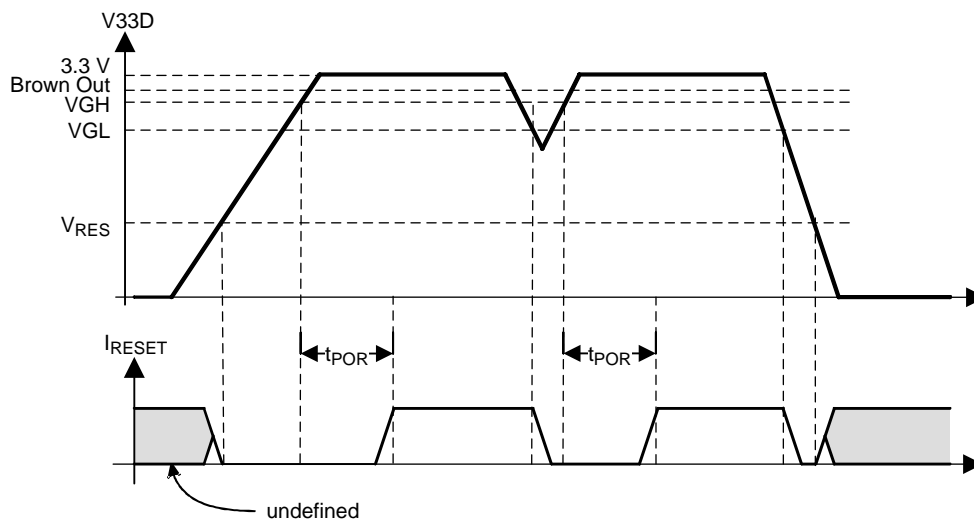

Figure 6-2. Power-On Reset (POR) and Brown-Out Reset (BOR)

Table 6-1. Power-On Reset (POR) and Brown-Out Reset (BOR) Term Definitions

TERM	DEFINITION
VGH	V33D threshold where the internal power is declared good. The device exits the reset state when above this threshold.
VGL	V33D threshold where the internal power is declared bad. The device enters reset state when below this threshold.
V _{res}	V33D threshold where the internal reset signal is no longer valid. Below this threshold the device is in an indeterminate state.
I _{Reset}	The internal reset signal. When low, the device is held in reset. This is equivalent to holding the device reset pin high.
t _{POR}	The time delay from when the VGH threshold exceeded to when the device exits the reset state.
Brown-out	The V33D voltage threshold at which the device sets the brown out status bit. An interrupt can be triggered if enabled.

7 Detailed Description

7.1 Overview

The UCD3138A family is a digital power supply controller from Texas Instruments offering superior levels of integration and performance in a single chip solution. The UCD3138, in comparison to Texas Instruments UCD3138A digital power controller offers 32 kB of program Flash memory. The flexible nature of the UCD3138A family makes it suitable for a wide variety of power conversion applications.

In addition, multiple peripherals inside the device have been specifically optimized to enhance the performance of AC/DC and isolated DC/DC applications and reduce the solution component count in the IT and network infrastructure space. The UCD3138A family is a fully programmable solution offering customers complete control of their application, along with ample ability to differentiate their solution. At the same time, TI is committed to simplifying our customer's development effort through offering best in class development tools, including application firmware, Code Composer Studio™ software development environment, and TI's Fusion Power Development GUI which enables customers to configure and monitor key system parameters.

7.2 ARM Processor

The ARM7TDMI-S processor is a synthesizable member of the ARM family of general purpose 32-bit microprocessors. The ARM architecture is based on RISC (reduced instruction set computer) principles where two instruction sets are available. The 32-bit ARM instruction set and the 16-bit Thumb instruction set. The Thumb instruction allows for higher code density equivalent to a 16-bit microprocessor, with the performance of the 32-bit microprocessor.

The three-staged pipelined ARM processor has fetch, decode and execute stage architecture. Major blocks in the ARM processor include a 32-bit ALU, 32 x 8 multiplier, and a barrel shifter.

7.3 Memory

The UCD3138A (ARM7TDMI-S) is a Von-Neumann architecture, where a single bus provides access to all of the memory modules. All of the memory module addresses are sequentially aligned along the same address range. This applies to program flash, data flash, ROM and all other peripherals.

Within the UCD3138A architecture, there is a Boot ROM that contains the initial firmware startup routines for PMBUS communication and non-volatile (FLASH) memory download. This boot ROM is executed after power-up-reset checks if there is a valid FLASH program written. If a valid program is present, the ROM code branches to the main FLASH-program execution.

UCD3138A also supports customization of the boot program by allowing an alternative boot routine to be executed from program FLASH. This feature enables assignment of a unique address to each device; therefore, enabling firmware reprogramming even when several devices are connected on the same communication bus.

Two separate FLASH memory areas are present inside the device. The 32 kB Program FLASH is organized as an 8 k x 32 bit memory block and is intended to be for the firmware program. The block is configured with page erase capability for erasing blocks as small as 1kB per page, or with a mass erase for erasing the entire program FLASH array. The FLASH endurance is specified at 1000 erase/write cycles and the data retention is good for 100 years. The 2 kB data FLASH array is organized as a 512 x 32 bit memory (32 byte page size). The Data FLASH is intended for firmware data value storage and data logging. Thus, the Data FLASH is specified as a high endurance memory of 20 k cycles with embedded error correction code (ECC).

For run time data storage and scratchpad memory, a 4 kB RAM is available. The RAM is organized as a 1 k x 32 bit array.

7.3.1 CPU Memory Map and interruptions

When the device comes out of power-on-reset, the data memories are mapped to the processor as follows:

Table 7-1. Memory Map (After Reset Operation)

Address	Size	Module
0x0000_0000 – 0x0000_FFFF In 16 repeated blocks of 4K each	16 X 4K	Boot ROM
0x0001_0000 – 0x0001_7FFF	32K	Program flash
0x0001_8800 – 0x0001_8FFF	2K	Data flash
0x0001_9000 – 0x0001_9FFF	4K	Data RAM

Just before the boot ROM program gives control to FLASH program, the ROM configures the memory as follows:

Table 7-2. Memory Map (Normal Operation)

Address	Size	Module
0x0000_0000 – 0x0000_7FFF	32K	Program flash
0x0001_0000 – 0x0001_AFFF	4K	Boot ROM
0x0001_8800 – 0x0001_8FFF	2K	Data flash
0x0001_9000 – 0x0001_9FFF	4K	Data RAM

Table 7-3. Memory Map (System and Peripherals Blocks)

Address	Size	Module
0x0002_0000 - 0x0002_00FF	256	Loop Mux
0x0003_0000 - 0x0003_00FF	256	Fault Mux
0x0004_0000 - 0x0004_00FF	256	ADC
0x0005_0000 - 0x0005_00FF	256	DPWM 3
0x0006_0000 - 0x0006_00FF	256	Filter 2
0x0007_0000 - 0x0007_00FF	256	DPWM 2
0x0008_0000 - 0x0008_00FF	256	Front End/Ramp I/F 2
0x0009_0000 - 0x0009_00FF	256	Filter 1
0x000A_0000 - 0x000A_00FF	256	DPWM 1
0x000B_0000 - 0x000B_00FF	256	Front End/Ramp I/F 1
0x000C_0000 - 0x000C_00FF	256	Filter 0
0x000D_0000 - 0x000D_00FF	256	DPWM 0
0x000E_0000 - 0x000E_00FF	256	Front End/Ramp I/F 0
0xFFFF7_EC00 - 0xFFFF7_ECFF	256	UART 0
0xFFFF7_ED00 - 0xFFFF7_EDFF	256	UART 1
0xFFFF7_F000 - 0xFFFF7_F0FF	256	Miscellaneous Analog Control
0xFFFF7_F600 - 0xFFFF7_F6FF	256	PMBus Interface
0xFFFF7_FA00 - 0xFFFF7_FAFF	256	GIO
0xFFFF7_FD00 - 0xFFFF7_FDFF	256	Timer
0xFFFF_FD00 - 0xFFFF_FDFF	256	MMC
0xFFFF_FE00 - 0xFFFF_FEFF	256	DEC
0xFFFF_FF20 - 0xFFFF_FF37	23	CIM
0xFFFF_FF40 - 0xFFFF_FF50	16	PSA
0xFFFF_FF00 - 0xFFFF_FFEC	28	SYS

The registers and bit definitions inside the system and peripheral blocks are detailed in the programmer's guide for each peripheral.

7.3.2 Boot ROM

The UCD3138A incorporates a 4k boot ROM. This boot ROM includes support for:

- Program download through the PMBus
- Device initialization
- Examining and modifying registers and memory
- Verifying and executing program FLASH automatically
- Jumping to a customer defined boot program

The Boot ROM is entered automatically on device reset. It initializes the device and then performs checksums on the Program FLASH. If the first 2 kB of program FLASH has a valid checksum, the program jumps to location 0 in the Program FLASH. This permits the use of a customer boot program. If the first checksum fails, it performs a checksum on the complete 32 kB of program flash. If this is valid, it also jumps to location 0 in the program flash. This permits full automated program memory checking, when there is no need for a custom boot program.

If neither checksum is valid, the Boot ROM stays in control, and accepts commands via the PMBus interface

These functions can be used to read and write to all memory locations in the UCD3138A. Typically they are used to download a program to Program Flash, and to command its execution

7.3.3 Customer Boot Program

It is possible to generate a user boot program using 2 kB or more of the program flash. This program can support features which the Boot ROM does not support, including:

- **Program download via UART.** This program is useful especially for applications where the UCD3138A is isolated from the host (for example, PFC)
- **Encrypted download.** This program is useful for code security in field updates.

7.3.4 Flash Management

The UCD3138A offers a variety of features providing for easy prototyping and easy flash programming. At the same time, high levels of security are possible for production code, even with field updates. Standard firmware stores multiple copies of system parameters in data flash. This is minimized the risk of losing information if programming is interrupted.

7.4 System Module

The System Module contains the interface logic and configuration registers to control and configure all the memory, peripherals and interrupt mechanisms. The blocks inside the system module are the address decoder, memory management controller, system management unit, central interrupt unit, and clock control unit.

7.4.1 Address Decoder (DEC)

The Address Decoder generates the memory selects for the FLASH, ROM and RAM arrays. The memory map addresses are selectable through configurable register settings. These memory selects can be configured from 1 kB to 16 MB. Power on reset uses the default addresses in the memory map for ROM execution, which is then configured by the ROM code to the application setup. During access to the DEC registers, a wait state is asserted to the CPU. DEC registers are writable in the ARM privilege mode only to enable user mode protection.

7.4.2 Memory Management Controller (MMC)

The MMC manages the interface to the peripherals by controlling the interface bus for extending the read and write accesses to each peripheral. The unit generates eight peripheral select lines with 1 kB of address space decoding.

7.4.3 System Management (SYS)

The SYS unit contains the software access protection by configuring user privilege levels to memory or peripherals modules. It contains the ability to generate fault or reset conditions on decoding of illegal address or access conditions. A clock control setup for the processor clock (MCLK) speed, is also available.

7.4.4 Central Interrupt Module (CIM)

The CIM accepts 32 interrupt requests for meeting firmware timing requirements. The ARM processor supports two interrupt levels: FIQ and IRQ. FIQ is the highest priority interrupt. The CIM provides hardware expansion of interruptions by use of FIQ/IRQ vector registers for providing the offset index in a vector table. This numerical index value indicates the highest precedence channel with a pending interrupt and is used to locate the interrupt vector address from the interrupt vector table. Interrupt channel 0 has the lowest precedence and interrupt channel 31 has the highest precedence. To remove the interrupt request, the firmware should clear the request as the first action in the interrupt service routine. The request channels are maskable, allowing individual channels to be selectively disabled or enabled.

Table 7-4. Interrupt Priority Table

NAME	MODULE COMPONENT OR REGISTER	DESCRIPTION	PRIORITY
BRN_OUT_INT	Brownout	Brownout interrupt	0 (lowest)
EXT_INT	External interruptions	Interrupt on external input pin	1
WDRST_INT	Watchdog control	Interrupt from watchdog exceeded (reset)	2
WDWAKE_INT	Watchdog control	Wakeup interrupt when watchdog equals half of set watch time	3
SCI_ERR_INT	UART or SCI control	UART or SCI error Interrupt. Frame, parity or overrun	4
SCI_RX_0_INT	UART or SCI control	UART0 RX buffer has a byte	5
SCI_TX_0_INT	UART or SCI control	UART0 TX buffer empty	6
SCI_RX_1_INT	UART or SCI control	UART1 RX buffer has a byte	7
SCI_TX_1_INT	UART or SCI control	UART1 TX buffer empty	8
PMBUS_INT		PMBus related interrupt	9
DIG_COMP_INT	12-bit ADC control	Digital comparator interrupt	10
FE0_INT	Front End 0	"Prebias complete", "Ramp Delay Complete", "Ramp Complete", "Load Step Detected", "Over-Voltage Detected", "EADC saturated"	11
FE1_INT	Front End 1	"Prebias complete", "Ramp Delay Complete", "Ramp Complete", "Load Step Detected", "Over-Voltage Detected", "EADC saturated"	12
FE2_INT	Front End 2	"Prebias complete", "Ramp Delay Complete", "Ramp Complete", "Load Step Detected", "Over-Voltage Detected", "EADC saturated"	13
PWM3_INT	16-bit timer PWM 3	16-bit Timer PWM3 counter overflow or compare interrupt	14
PWM2_INT	16-bit timer PWM 2	16-bit Timer PWM2 counter Overflow or compare interrupt	15
PWM1_INT	16-bit timer PWM 1	16-bit Timer PWM1 counter overflow or compare interrupt	16
PWM0_INT	16-bit timer PWM 0	16-bit Timer PWM1 counter overflow or compare interrupt	17
OVF24_INT	24-bit timer control	24-bit Timer counter overflow interrupt	18
DTC_FLT_INT	DTC fault interrupt	DTC module fault interrupt	19
COMP_1_INT	24-bit timer control	24-bit Timer compare 1 interrupt	20

Table 7-4. Interrupt Priority Table (continued)

NAME	MODULE COMPONENT OR REGISTER	DESCRIPTION	PRIORITY
CAPTURE_0_INT	24-bit timer control	24-bit Timer capture 0 interrupt	21
COMP_0_INT	24-bit timer control	24-bit Timer compare 0 interrupt	22
CPCC_INT	Constant power constant current	Mode switched in CPCC module Flag needs to be read for details	23
ADC_CONV_INT	12-bit ADC control	ADC end of conversion interrupt	24
FAULT_INT	Fault Mux interrupt	Analog comparator interruptions, overvoltage detection, undervoltage detection, LLM load step detection	25
DPWM3	DPWM3	Same as DPWM1	26
DPWM2	DPWM2	Same as DPWM1	27
DPWM1	DPWM1	1) Every (1 to 256) switching cycles 2) Fault detection 3) Mode switching	28
DPWM0	DPWM0	Same as DPWM1	29
EXT_FAULT_INT	External Faults	Fault pin interrupt	30
SYS_SSI_INT	System Software	System software interrupt	31 (highest)

7.5 Feature Description

7.5.1 Sync FET Ramp and IDE Calculation

The UCD3138A has built in logic for controlling MOSFETs for synchronous rectification (Sync FETs). This comes in two forms:

- Sync FET ramp
- Ideal Diode Emulation (IDE) calculation

When starting up a power supply, sometimes there is already a voltage on the output – this is called prebias. It is difficult to calculate the ideal Sync FET on-time for this case. If it is not calculated correctly, it may pull down the prebias voltage, causing the power supply to sink current.

To avoid this, Sync FETs are not turned on until the power supply has ramped up to the nominal voltage. The Sync FETs are turned on gradually in order to avoid an output voltage glitch. The Sync FET Ramp logic can be used to turn them on at a rate below the bandwidth of the filter.

In discontinuous mode, the ideal on-time for the Sync FETs is a function of V_{IN} , V_{OUT} , and the primary side duty cycle (D). The IDE logic in the UCD3138A takes V_{IN} and V_{OUT} data from the firmware and combines it with D data from the filter hardware. It uses this information to calculate the ideal on-time for the Sync FETs.

7.5.2 Automatic Mode Switching

Automatic Mode switching enables the DPWM module to switch between modes automatically. This is useful to increase efficiency and power range. The following paragraphs describe phase-shifted full bridge and LLC examples:

7.5.2.1 Phase Shifted Full Bridge Example

Phase shifted full bridge topologies are shown in [Figure 7-1](#) and [Figure 7-2](#).

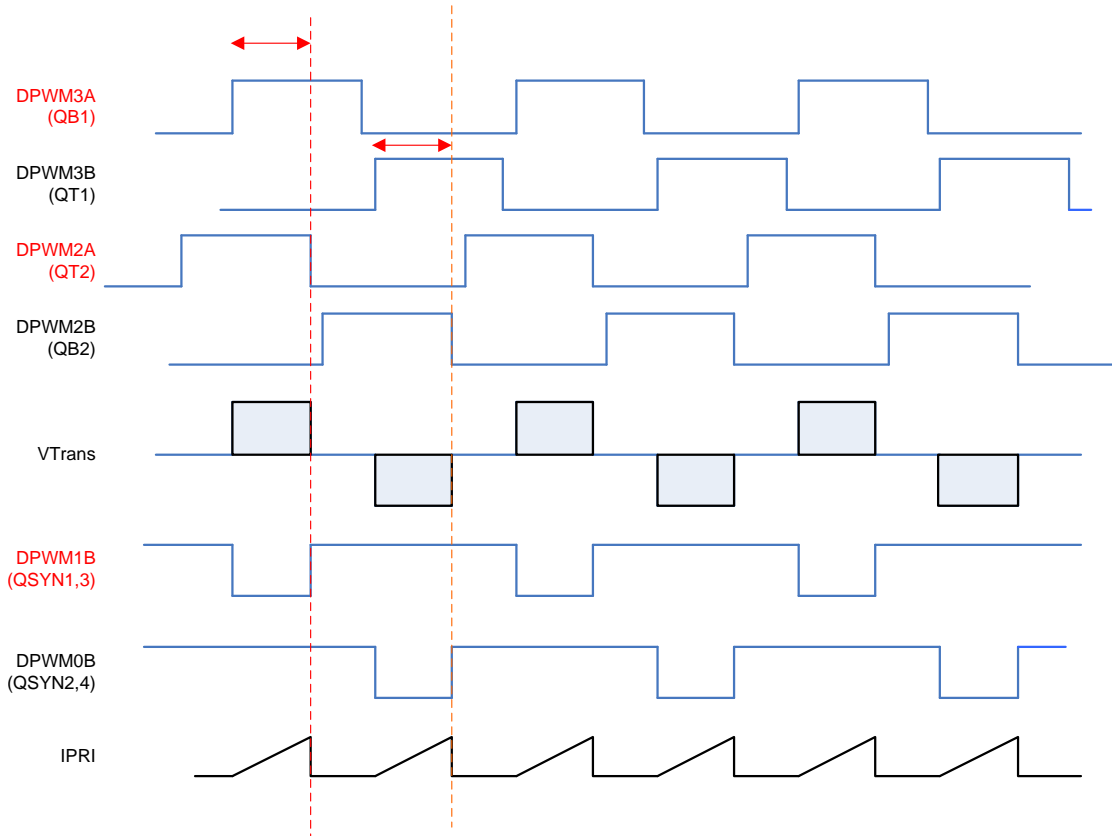

Figure 7-1. Phase Shifted Full Bridge

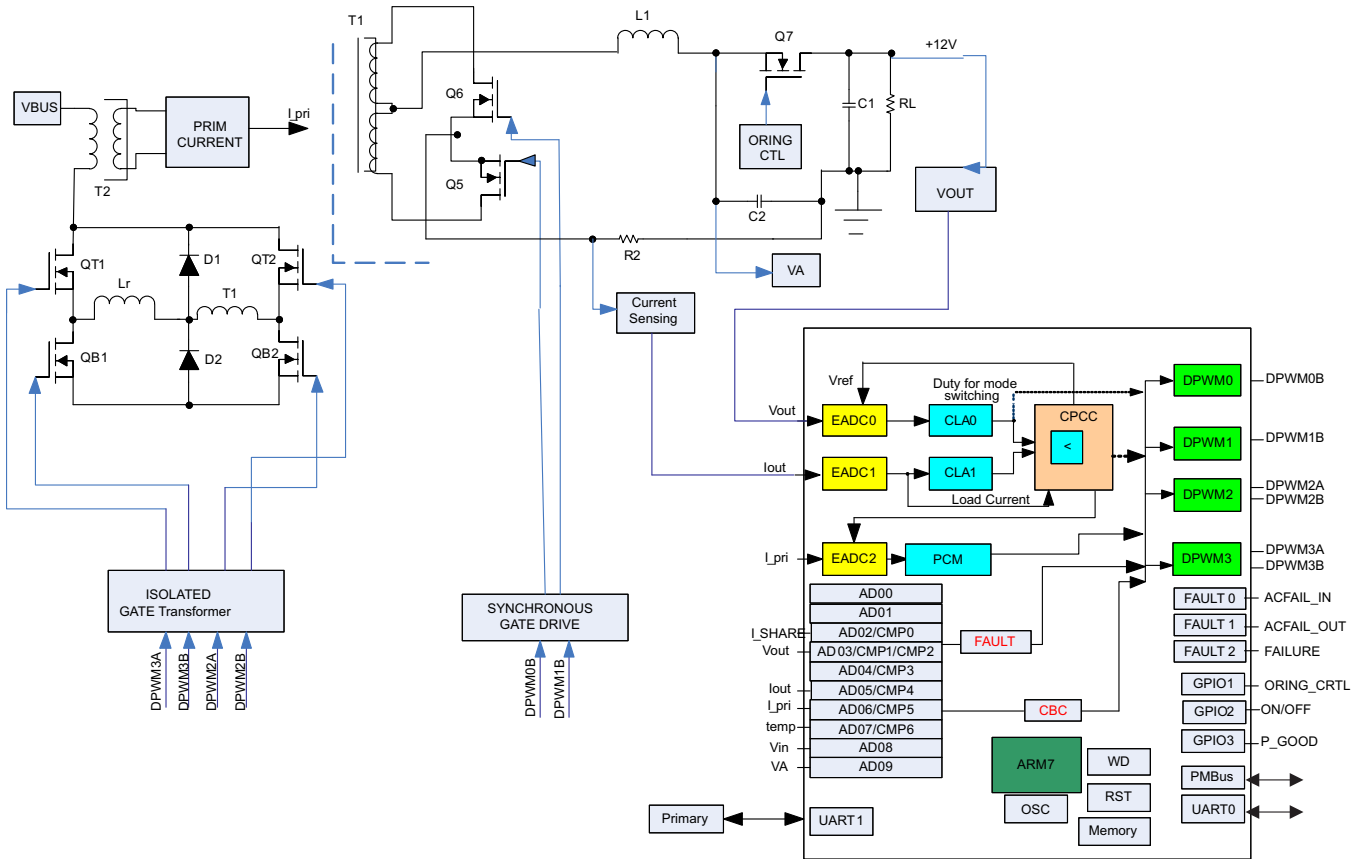
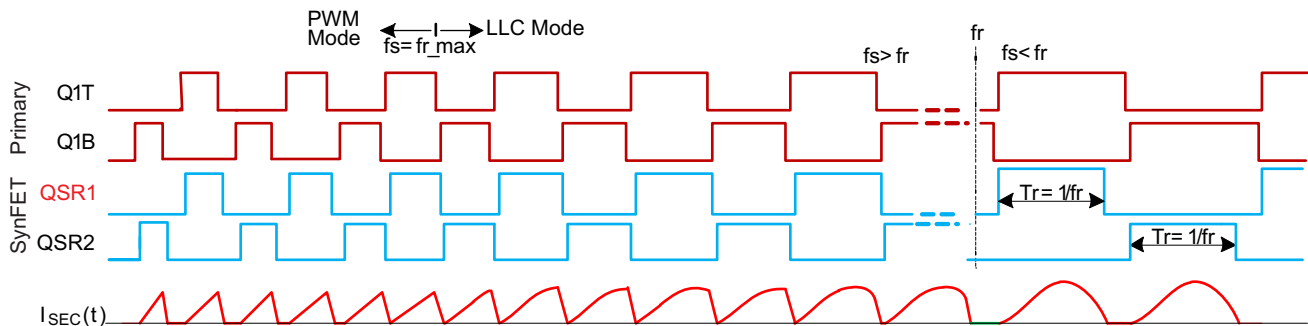

Figure 7-2. Secondary-Referenced Phase-Shifted Full Bridge Control With Synchronous Rectification

7.5.2.2 LLC Example

In LLC, three modes are used. At the highest frequency, a pulse width modulated mode (Multi Mode) is used. As the frequency decreases, resonant mode is used. As the frequency gets still lower, the synchronous MOSFET drive changes so that the on-time is fixed and does not increase. In addition, the LLC control supports cycle-by-cycle current limiting. This protection function operates by a comparator monitoring the maximum current during the DPWMA conduction time. Any time this current exceeds the programmable comparator reference the pulse is immediately terminated. Due to classic instability issues associated with half-bridge topologies it is also possible to force DPWMB to match the truncated pulse width of DPWMA. Here are the waveforms for the LLC:



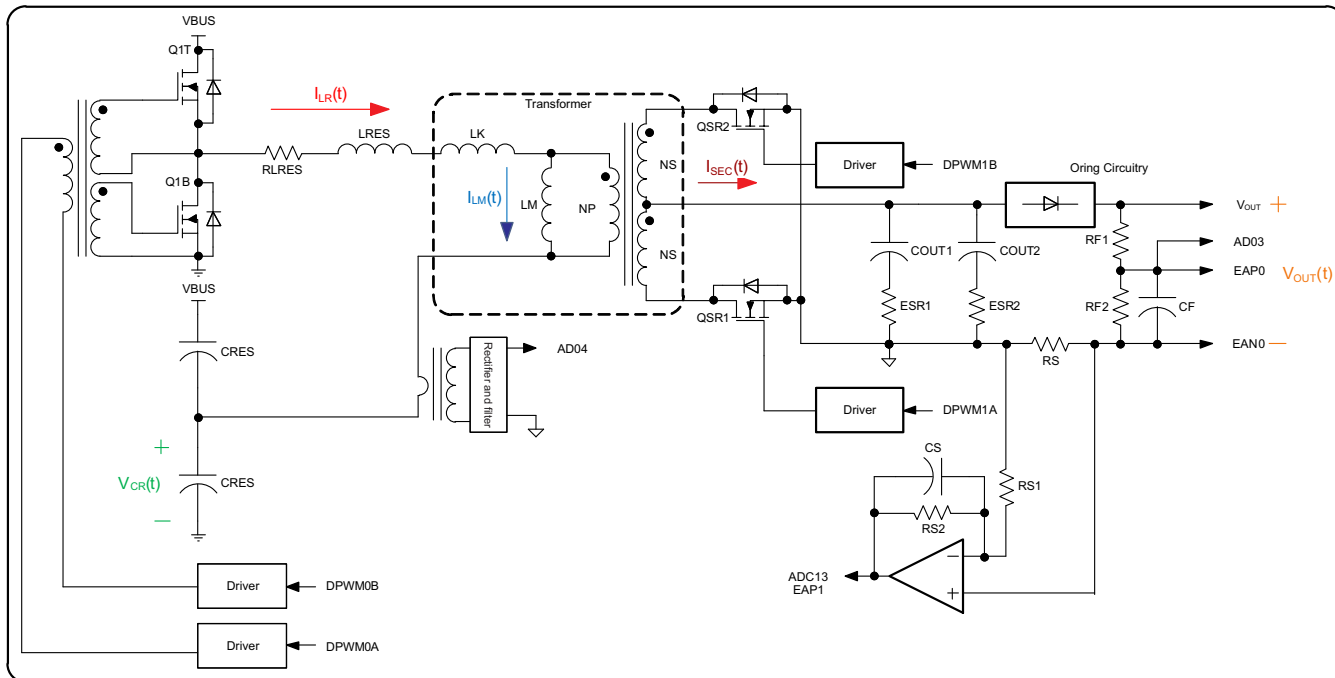

Figure 7-3. Secondary-Referenced Half-Bridge Resonant LLC Control With Synchronous Rectification

7.5.2.3 Mechanism for Automatic Mode Switching

The UCD3138A allows the customer to enable up to two distinct levels of automatic mode switching. These different modes are used to enhance light load operation, short circuit operation and soft start. Many of the configuration parameters for the DPWM are in DPWM Control Register 1. For automatic mode switching, some of these parameters are duplicated in the Auto Config Mid and Auto Config High registers.

If automatic mode switching is enabled, the filter duty signal is used to select which of these three registers is used. There are 4 registers which are used to select the points at which the mode switching takes place. They are used as shown in [Figure 7-4](#).

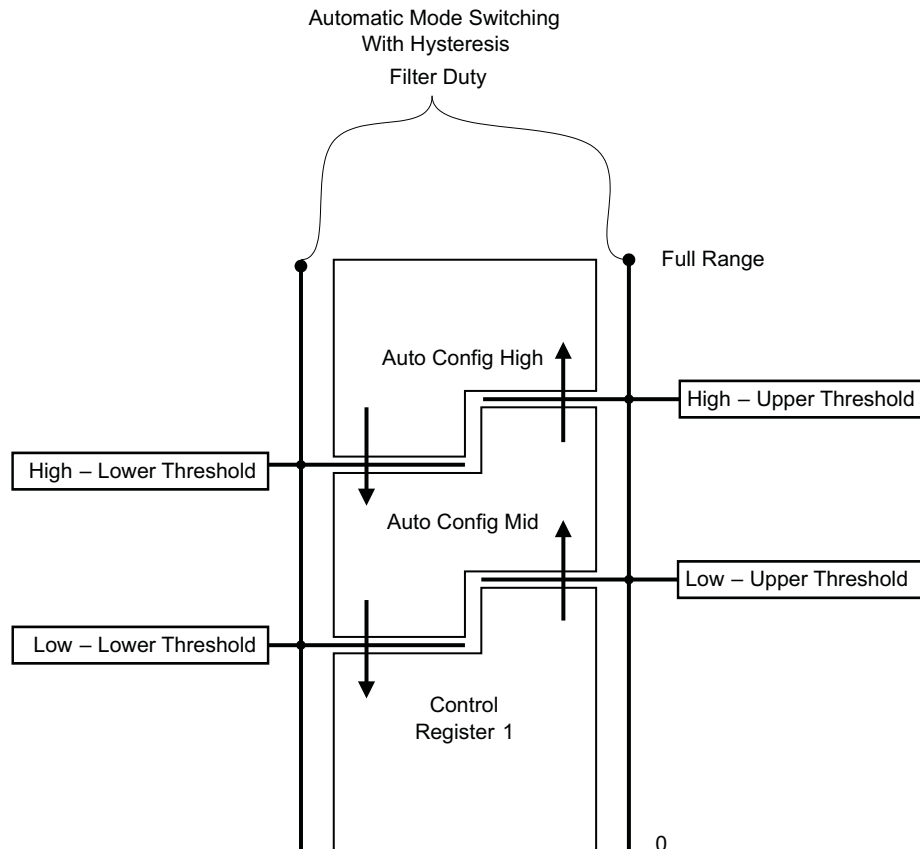

Figure 7-4. Automatic Mode Switching

As shown, the registers are used in pairs for hysteresis. The transition from Control Register 1 to Auto Config Mid only takes place when the Filter Duty goes above the Low Upper threshold. It does not go back to Auto Config Mid until the Low Lower Threshold is passed. This prevents oscillation between modes if the filter duty is close to a mode switching point.

7.5.3 DPWMC, Edge Generation, IntraMux

The UCD3138A has hardware for generating complex waveforms beyond the simple DPWMA and DPWMB waveforms already discussed – DPWMC, the Edge Generation Module, and the IntraMux.

DPWMC is an auxiliary signal inside the DPWM logic. It can be generated using the Blanking A begin time, and the Blanking A end time.

The Edge Gen module takes DPWMA and DPWMB from its own DPWM module, and the next one, and uses them to generate edges for two outputs. For DPWM3, the DPWM0 is considered to be the next DPWM. Each edge (rising and falling for DPWMA and DPWMB) has 8 options which can output a generated edge.

The options are:

- 0 = DPWM(n) A Rising edge
- 1 = DPWM(n) A Falling edge
- 2 = DPWM(n) B Rising edge
- 3 = DPWM(n) B Falling edge
- 4 = DPWM(n+1) A Rising edge
- 5 = DPWM(n+1) A Falling edge
- 6 = DPWM(n+1) B Rising edge
- 7 = DPWM(n+1) B Falling edge

Where “n” is the numerical index of the DPWM module of interest. For example n = 1 refers to DPWM1.

The Edge Gen is controlled by the DPWMEDGEGEN register.

The IntraMux (short for intra multiplexer) is controlled by the Auto Config registers. The IntraMux takes signals from multiple DPWMs and from the Edge Gen and combines them logically to generate DPWMA and DPWMB signals. This is useful for topologies like phase-shifted full bridge, especially when they are controlled with automatic mode switching. When disabled, DPWMA and DPWMB are driven as described in the [Section 7.5.2](#) section. If the Intra Mux is enabled, the high-resolution feature must be disabled, and the DPWM edge resolution falls to 4 ns.

The Edge Gen/Intra Mux is shown in [Figure 7-5](#).

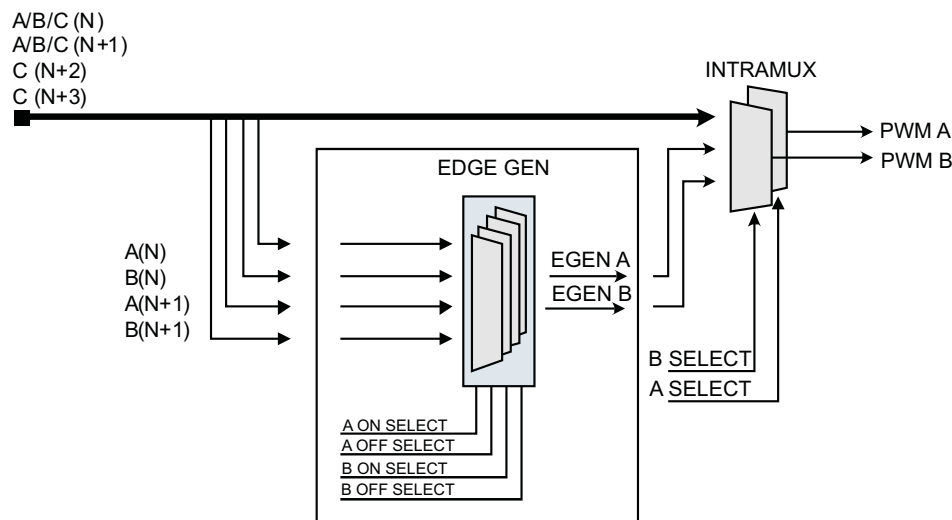

Figure 7-5. Edge Gen/Intra Mux

A list of the IntraMux modes for DPWMA is as follows:

- 0 = DPWMA(n) pass through (default)
- 1 = Edge-gen output, DPWMA(n)
- 2 = DPWNC(n)
- 3 = DPWMB(n) (Crossover)
- 4 = DPWMA(n+1)
- 5 = DPWMB(n+1)
- 6 = DPWMC(n+1)
- 7 = DPWMC(n+2)
- 8 = DPWMC(n+3)

and for DPWMB:

- 0 = DPWMB(n) pass through (default)
- 1 = Edge-gen output, DPWMB(n)
- 2 = DPWNC(n)
- 3 = DPWMA(n) (Crossover)
- 4 = DPWMA(n+1)
- 5 = DPWMB(n+1)
- 6 = DPWMC(n+1)
- 7 = DPWMC(n+2)
- 8 = DPWMC(n+3)

The DPWM number wraps around just like the Edge Gen unit. For DPWM3 the following definitions apply:

DPWM(n)	DPWM3
DPWM(n+1)	DPWM0
DPWM(n+2)	DPWM1
DPWM(n+3)	DPWM2

7.5.4 Filter

The UCD3138A filter is a PID filter with many enhancements for power supply control. Some of its features include:

- Traditional PID Architecture
- Programmable non-linear limits for automated modification of filter coefficients based on received EADC error
- Multiple coefficient sets fully configurable by firmware
- Full 24-bit precision throughout filter calculations
- Programmable clamps on integrator branch and filter output
- Ability to load values into internal filter registers while system is running
- Ability to stall calculations on any of the individual filter branches
- Ability to turn off calculations on any of the individual filter branches
- Duty cycle, resonant period, or phase shift generation based on filter output.
- Flux balancing
- Voltage feed forward

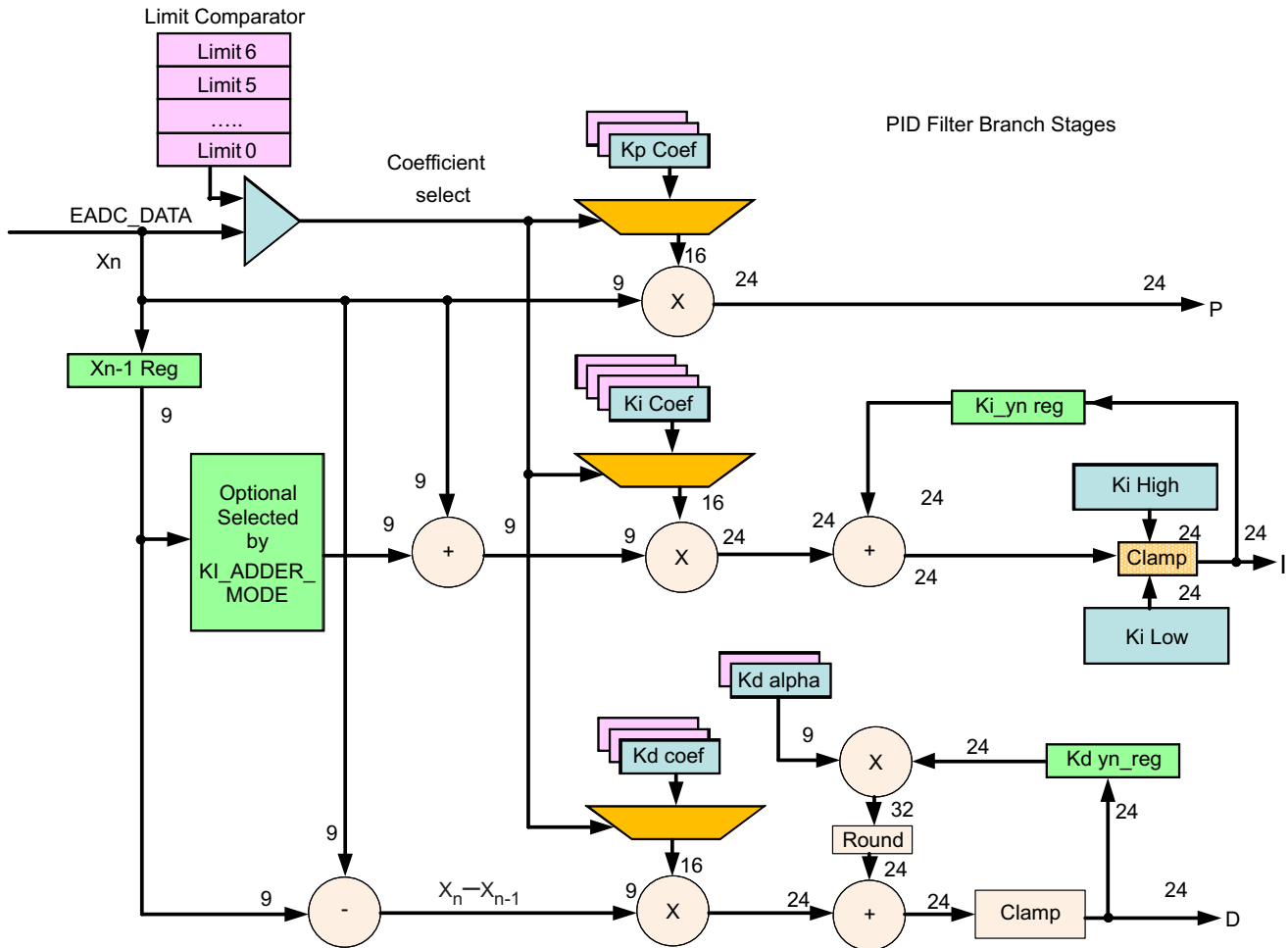

Figure 7-6. First Section of the Filter

The filter input, X_n , generally comes from a front end. Then there are three branches, P, I, and D. Note that the D branch also has a pole, Kd Alpha. Clamps are provided both on the I branch and on the D alpha pole.

The filter also supports a nonlinear mode, where up to 7 different sets of coefficients can be selected depending on the magnitude of the error input X_n . This can be used to increase the filter gain for higher errors to improve transient response.

The output section of the filter (S0.23 means that there is 1 sign bit, 0 integer bits and 23 fractional bits) is shown in Figure 7-7

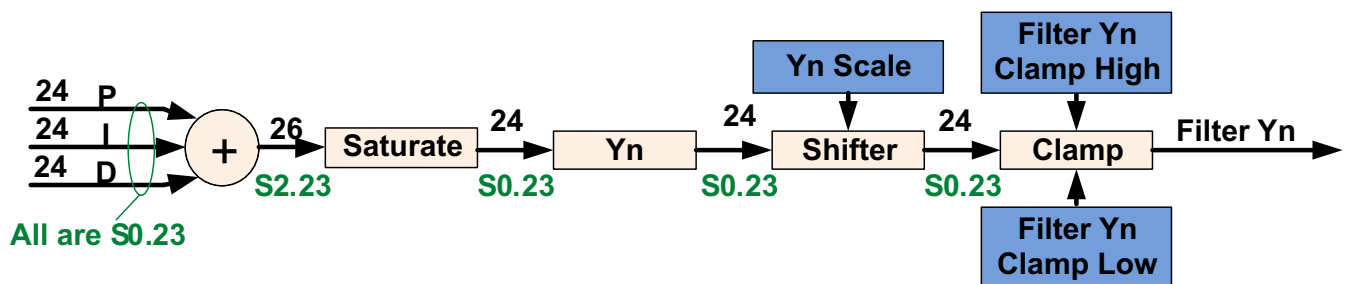

Figure 7-7. Output Section of the Filter

This section combines the P, I, and D sections, and provides for saturation, scaling, and clamping.

The final section for the filter, which permits its output to be matched to the DPWM is shown in [Figure 7-8](#).

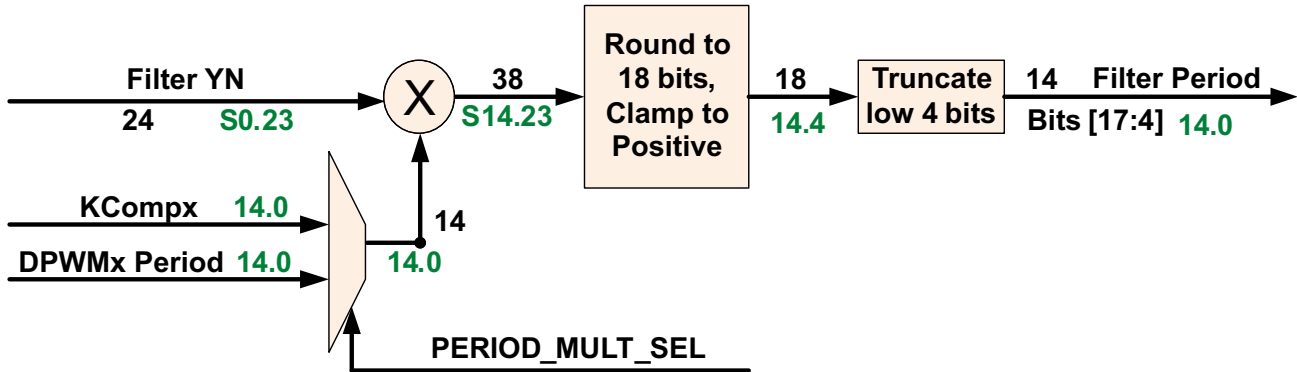

Figure 7-8. Final Section for the Filter

This permits the filter output to be multiplied by a variety of correction factors to match the DPWM Period, to provide for Voltage Feed Forward, or for other purposes. After this, there is another clamp. For resonant mode, the filter can be used to generate both period and duty cycle.

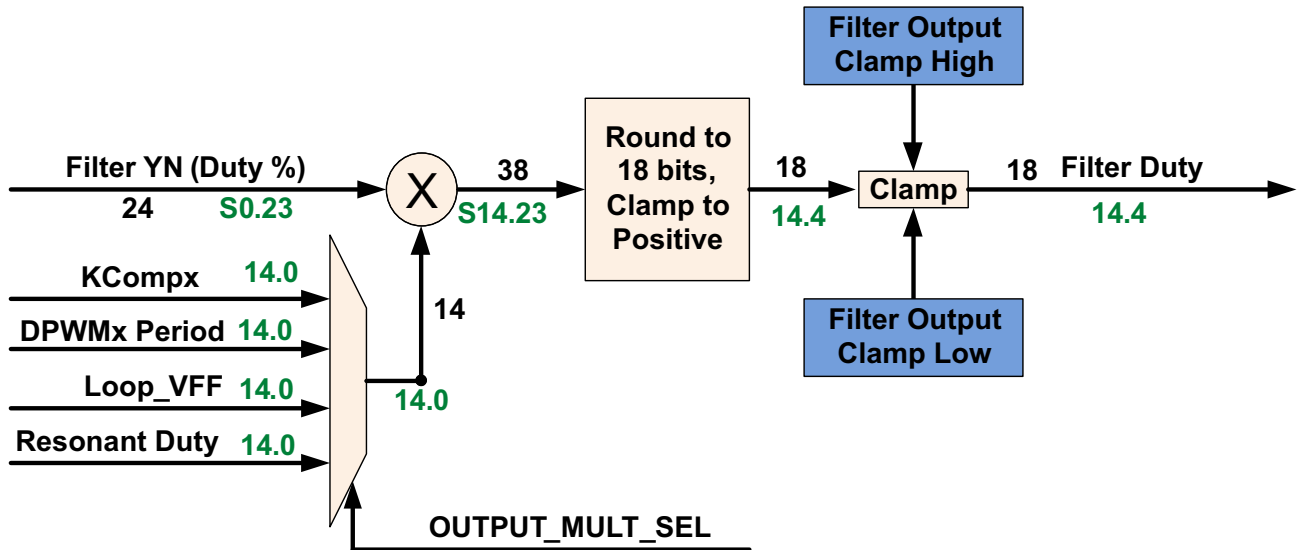

Figure 7-9. Resonant Mode

7.5.4.1 Loop Multiplexer

The Loop Mux controls interconnections between the filters, front ends, and DPWMs. Any filter, front end, and DPWM can be combined with each other in many configurations.

It also controls the following connections:

- DPWM to Front End
- Front End DAC control from Filters or Constant Current/Constant Power Module
- Filter Special Coefficients and Feed Forward
- DPWM synchronization
- Filter to DPWM

The following control modules are configured in the Loop Mux:

- Constant Power/Constant Current
- Cycle Adjustment (Current and flux balancing)

- Global Period
- Light Load (Burst Mode)
- Analog Peak Current Mode

7.5.4.2 Fault Multiplexer

In order to allow a flexible way of mapping several fault triggering sources to all the DPWMs channels, the UCD3138A provides an extensive array of multiplexers that are united under the name Fault Mux module.

The Fault Mux Module supports flexible mapping between fault sources and fault response mechanism inside each DPWM module.

- Many fault sources can be mapped to a single fault response mechanism. For instance an analog comparator in charge of over voltage protection, a digital comparator in charge of over current protection and an external digital fault pin can be all mapped to a fault-A signal connected to a single FAULT MODULE and shut down DPWM1-A.
- A single fault source can be mapped to many fault response mechanisms inside many DPWM modules. For instance an analog comparator in charge of over current protection can be mapped to DPWM-0 through DPWM-3 by way of several fault modules.

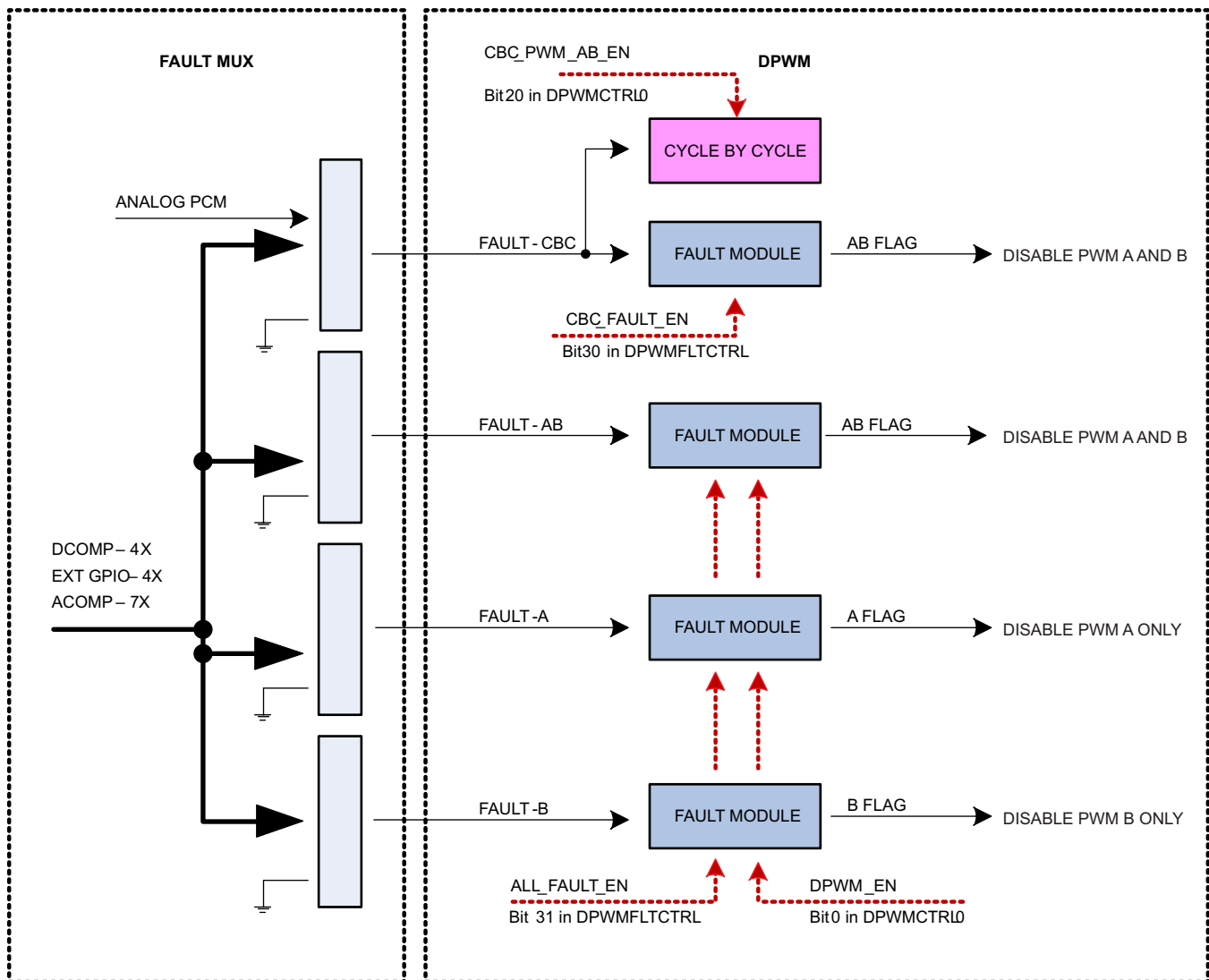

The Fault Mux Module provides a multitude of fault protection functions within the UCD3138A high-speed loop (front end control, filter, DPWM and loop Mux modules). The Fault Mux Module allows highly configurable fault generation based on digital comparators, high-speed analog comparators and external fault pins. Each of the fault inputs to the DPWM modules can be configured to one or any combination of the fault events provided in the Fault Mux Module.

Each one of the DPWM engines has four fault modules. The modules are called CBC fault module, AB fault module, A fault module and B fault module.

The internal circuitry in all the four fault modules is identical, and the difference between the modules is limited to the output it affects under a fault condition.

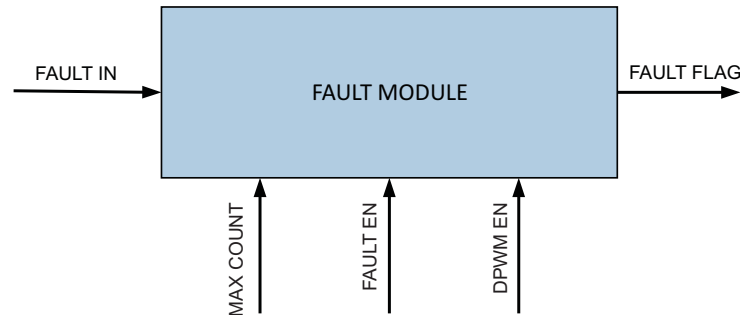

Figure 7-10. Fault Module

All fault modules are capable of detecting faults only once per DPWM switching cycle. Each one of the fault modules have a separate max_count value and the device sets the fault flag only when the sequential faults count exceeds the max_count value.

After the fault flag is set, DPWMs must be disabled by DPWM_EN going low in order to clear the fault flags.

NOTE

All four fault modules share the same DPWM_EN control. The device clears all fault flags (output of fault modules) simultaneously.

All four Fault Modules share the same global FAULT_EN as well. Therefore, a specific Fault Module cannot be enabled/ disabled separately.



Figure 7-11. Cycle by Cycle Block

In contrast to the fault modules, only one cycle by cycle block is available in each DPWM module.

The cycle by cycle block can work in conjunction with CBC Fault Module and enables DPWM reaction to signals arriving from analog peak current mode (PCM) module.

The fault Mux module supports the following basic functions:

- 4 digital comparators with programmable thresholds and fault generation
- Configuration for 7 high-speed analog comparators with programmable thresholds and fault generation
- External GPIO detection control with programmable fault generation
- Configurable DPWM fault generation for DPWM current limit fault, DPWM overvoltage detection fault, DPWM A external fault, DPWM B external fault and DPWM IDE flag
- Clock failure detection for high and low frequency oscillator blocks

- Discontinuous conduction mode detection

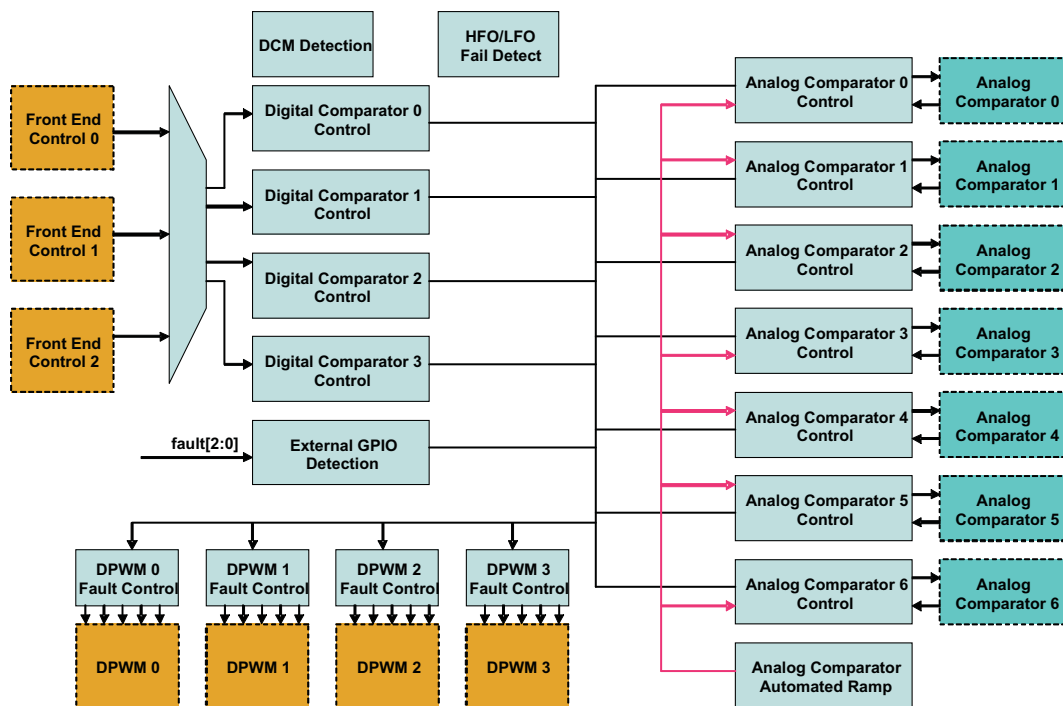

Figure 7-12. Fault Mux Block Diagram

7.5.5 Communication Ports

7.5.5.1 SCI (UART) Serial Communication Interface

A maximum of two independent Serial Communication Interface (SCI) or Universal Asynchronous Receiver/Transmitter pre-scaler (UART) interfaces are included within the device for asynchronous start-stop serial data communication (see the pin out sections for details) Each interface has a 24 bit for supporting programmable baud rates and has programmable data word and stop bit options. Half or full duplex operation is configurable through register bits. A loop back feature can also be setup for firmware verification. Both SCI-TX and SCI-RX pin sets can be used as GPIO pins when the peripheral is not being used. Both the UART ports support Hardware auto baud correction improving robustness in communication even at higher baud rates.

7.5.5.2 PMBus Interfacte

The PMBus Interface supports independent master and slave modes controlled directly by firmware through a processor bus interface. Individual control and status registers enable firmware to send or receive I²C, SMBus or PMBus messages in any of the accepted protocols, in accordance with the I²C Specification, SMBus Specification (Version 2.0) and the PMBUS Power System Management Protocol Specification (PMBus 1.3).

The PMBus interface is controlled through a processor bus interface, utilizing a 32-bit data bus and 6-bit address bus. The PMBus interface is connected to the expansion bus, which features 4 byte write enables, a peripheral select dedicated for the PMBus interface, separated 32-bit data buses for reading and writing of data and active-low write and output enable control signals. In addition, the PMBus Interface connects directly to the I²C/SMBus/PMBus Clock, Data, Alert, and Control signals.

Example: PMBus Address Decode via ADC12 Reading

The user can allocate 2 pins of the 12-bit ADC input channels, AD_00 and AD_01, for PMBus address decoding. At power-up the device applies I_{BIAS} to each address detect pin and the voltage on that pin is captured by the internal 12-bit ADC.

R_{ADDSET} is the resistor that sets the PMBus address. $\text{Bin}(V_{AD0x})$ is the address bin for one of 12 address as shown in [Figure 7-13](#).

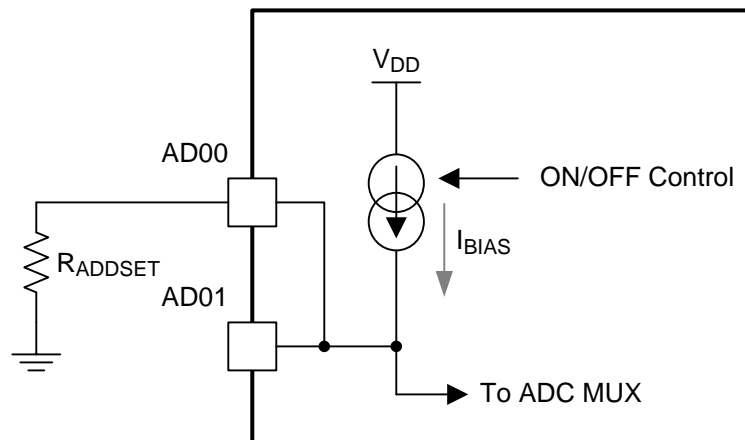

Figure 7-13. PMBus Address Detection Method

7.5.5.3 General Purpose ADC12

The ADC12 is a 12-bit, high speed analog-to-digital converter, equipped with the following options:

- Typical conversion speed of 267 ksp/s
- Conversions can consist from 1 to 16 ADC channel conversions in any desired sequence
- Post conversion averaging capability, ranging from 4X, 8X, 16X or 32X samples
- Configurable triggering for ADC conversions from the following sources: firmware, DPWM rising edge, ADC_EXT_TRIG pin or Analog Comparator results
- Interrupt capability to embedded processor at completion of ADC conversion
- Six digital comparators on the first 6 channels of the conversion sequence using either raw ADC data or averaged ADC data
- Two 10 μA current sources for excitation of PMBus addressing resistors
- Dual sample and hold for accurate power measurement
- Internal temperature sensor for temperature protection and monitoring

The control module [ADC12 Control Block Diagram](#) contains the control and conversion logic for auto-sequencing a series of conversions. The sequencing is fully configurable for any combination of 16 possible ADC channels through an analog multiplexer embedded in the ADC12 block. Once converted, the selected channel value is stored in the result register associated with the sequence number. Input channels can be sampled in any desired order or programmed to repeat conversions on the same channel multiple times during a conversion sequence. Selected channel conversions are also stored in the result registers in order of conversion, where the result 0 register is the first conversion of a 16-channel sequence and result 15 register is the last conversion of a 16-channel sequence. The number of channels converted in a sequence can vary from 1 to 16.

Unlike EADC0 through EADC2, which are primarily designed for closing high speed compensation loops, the ADC12 is not usually used for loop compensation purposes. The EADC converters have a substantially faster conversion rate, thus making them more attractive for closed loop control. The ADC12 features make it best suited for monitoring and detection of currents, voltages, temperatures and faults. Please see the [Typical Characteristics](#) plots for the temperature variation associated with this function.

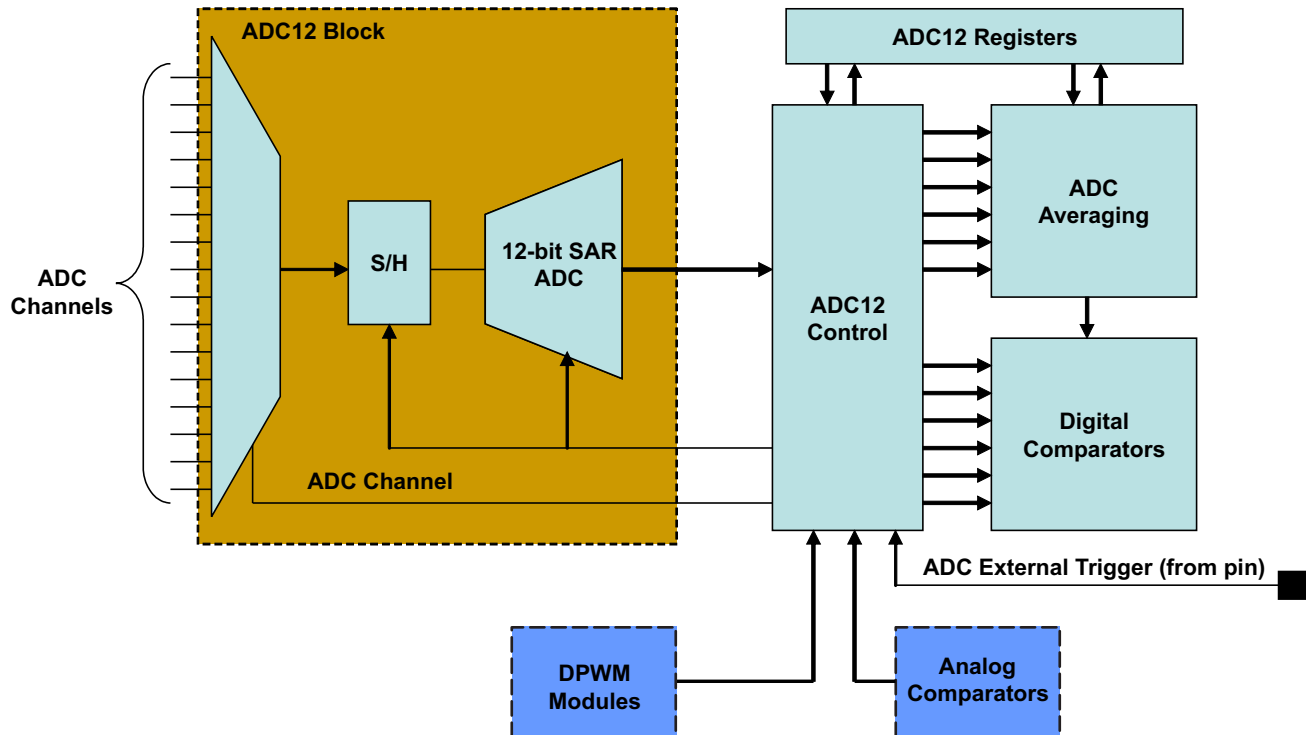

Figure 7-14. ADC12 Control Block Diagram

7.5.5.4 Timers

External to the Digital Power Peripherals there are 3 different types of timers in UCD3138A . They are the 24-bit timer, 16-bit timer and the Watchdog timer

7.5.5.4.1 24-bit PWM Timer

There is one 24 bit counter PWM timer which runs off the Interface Clock and can further be divided down by an 8-bit pre-scalar to generate a slower PWM time period. The timer has two compare registers (Data Registers) for generating the PWM set/unset events. Additionally, the timer has a shadow register (Data Buffer register) which can be used to store CPU updates of the compare events while still using the timer. The selected shadow register update mode happens after the compare event matches.

The two capture pins TCMP0 and TCMP1 are inputs for recording a capture event. A capture event can be set either to rising, falling, or both edges of the capture pin. Upon this event, the counter value is stored in the corresponding capture data register.

The counter reset can be configured to happen on a counter roll over, a compare equal event, or by software controlled register. Five interruptions from the PWM timer can be set, which are the counter rollover event (overflow), either capture event 0 or 1, or the two comparison match events. Each interrupt can be disabled or enabled.

Upon an event comparison on only the second event, the TCMP pin can be configured to set, clear, toggle or have no action at the output. The value of PWM pin output can be read for status or simply configured as general purpose I/O for reading the value of the input at the pin. The first compare event can only be used as an interrupt.

7.5.5.4.2 16-Bit PWM Timers

There are four 16 bit counter PWM timers which run off the Interface Clock and can further be divided down by a 8-bit pre-scaler to generate slower PWM time periods. Each timer has two compare registers (Data Registers) for generating the PWM set/unset events. Additionally, each timer has a shadow register (Data Buffer register) which can be used to store CPU updates of compare events while still using the timer. The selected shadow register update mode happens after the compare event matches.

The counter reset can be configured to happen on a counter roll over, a compare equal event, or by a software controlled register. interruptions from the PWM timer can be set due to the counter rollover event (overflow) or by the two comparison match events. Each comparison match and the overflow interruptions can be disabled or enabled.

Upon an event comparison, the PWM pin can be configured to set, clear, toggle or have no action at the output. The value of PWM pin output can be read for status or simply configured as General Purpose I/O for reading the value of the input at the pin.

7.5.5.4.3 Watchdog Timer

A watchdog timer is provided on the device for ensuring proper firmware loop execution. The timer is clocked off of a separate low speed oscillator source. If the timer is allowed to expire, a reset condition is issued to the ARM processor. The watchdog is reset by a simple CPU write bit to the watchdog key register by the firmware routine. On device power-up the watchdog is disabled. Yet after it is enabled, the watchdog cannot be disabled by firmware. Only a device reset can put this bit back to the default disabled state. A half timer flag is also provided for status monitoring of the watchdog.

7.5.6 Miscellaneous Analog

The Miscellaneous Analog Control (MAC) Registers provide control and monitor a wide variety of functions. These functions include device supervisory features such as brown-out and power saving configuration, general purpose input and output configuration and interfacing, internal temperature sensor control and current sharing control.

The MAC module provides trim signals to the oscillator and AFE blocks. These controls are usually used at the time of trimming at manufacturing; therefore this data sheet does not include any descriptions of these trim controls.

The MAC registers and peripherals are all available in the 64-pin version. Other UCD3138A devices may have reduced resources. See also the [Section 4](#) section.

7.5.7 Package ID Information

Package ID register includes information regarding the package type of the device and can be read by firmware for reporting through PMBus or for other package sensitive decisions.

BIT NUMBER	1:0
Bit Name	PKG_ID
Access	R/W
Default	0 – UCD3138A RHA

7.5.8 Brownout

Brownout function is used to determine if the device supply voltage is lower than a threshold voltage, a condition that may be considered unsafe for proper operation of the device.

The brownout threshold is higher than the reset threshold voltage; therefore, when the supply voltage is lower than brownout threshold, it still does not necessarily trigger a device reset.

The brownout interrupt flag can be polled or alternatively can trigger an interrupt to service such case by an interrupt service routine. See .

7.5.9 Global I/O

Up to 30 pins in the UCD3138A device can be configured to serve as a general purpose input or output pin (GPIO). This includes all digital input or output pins except for the RESET pin.

The pins that cannot be configured as GPIO pins are the supply pins, ground pins, ADC-12 analog input pins, EADC analog input pins and the RESET pin.

There are two ways to configure and use the digital pins as GPIO pins:

- Through the centralized Global I/O control registers.
- Through the distributed control registers in the specific peripheral that shares it pins with the standard GPIO functionality.

The Global I/O registers offer full control of:

- Configuring each pin as a GPIO.
- Setting each pin as input or output.
- Reading the pin's logic state, if it is configured as an input pin.
- Setting the logic state of the pin, if it is configured as an output pin.
- Configuring pin/pins as open drain or push-pull (Normal)

The Global I/O registers include Global I/O EN register, Global I/O OE Register, Global I/O Open Drain Control Register, Global I/O Value Register and Global I/O Read Register.

The following is showing the format of Global I/O EN Register (GLBIOEN) as an example:

BIT NUMBER	29:0
Bit Name	GLOBAL_IO_EN
Access	R/W
Default	00_0000_0000_0000_0000_0000_0000_0000

Bits 29-0: GLOBAL_IO_EN – This register enables the global control of digital I/O pins

0 = Control of IO is done by the functional block assigned to the IO (Default)

1 = Control of IO is done by Global IO registers.

BIT	PIN_NAME	PIN NUMBER	
		UCD3138A-64 PINS	UCD3138A-40 PINS
29	FAULT[3]	43	NA
28	ADC_EXT_TRIG	12, 26	8
27	TCK	37	21
26	TDO	38	20
25	TMS	40	24
24	TDI	39	23
23	SCI_TX[1]	29	NA
22	SCI_TX[0]	14	22
21	SCI_RX[1]	30	NA
20	SCI_RX[0]	13	23
19	TMR_CAP	12, 26, 41	8, 21
18	TMR_PWM[1]	32	NA
17	TMR_PWM[0]	12, 26, 31, 37	21
16	PMBUS-CLK	15	9
15	PMBUS-DATA	16	10
14	CONTROL	30	20
13	ALERT	29	19
12	EXT_INT	26, 34	NA

BIT	PIN_NAME	PIN NUMBER	
		UCD3138A-64 PINS	UCD3138A-40 PINS
11	FAULT[2]	42	25
10	FAULT[1]	36	23
9	FAULT[0]	35, 39	22
8	SYNC	12, 26,37	8, 21
7	DPWM3B	24	18
5	DPWM2B	22	16
4	DPWM2A	21	15
3	DPWM1B	20	14
2	DPWM1A	19	13
1	DPWM0B	18	12
0	DPWM0A	17	11

7.5.10 Temperature Sensor Control

Temperature sensor control register provides internal temperature sensor enabling and trimming capabilities. The internal temperature sensor is disabled as default.

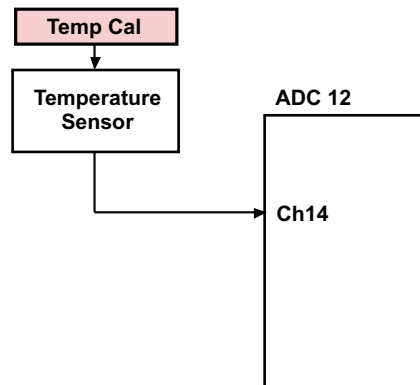

Figure 7-15. Internal Temp Sensor

Temperature sensor is calibrated at room temperature (25°C) via a calibration register value.

The temperature sensor is measured using ADC12 (via Ch14). The temperature is then calculated using a mathematical formula involving the calibration register (this effectively adds a delta to the ADC measurement).

The temperature sensor can be enabled or disabled.

7.5.11 I/O Mux Control

In different packages of UCD3138A several I/O functions are multiplexed and routed toward a single physical pin. I/O Mux Control register may be used in order to choose a single specific functionality that is desired to be assigned to a physical device pin for your application.

7.5.12 Current Sharing Control

UCD3138A provides three separate modes of current sharing operation.

- Analog bus current sharing
- PWM bus current sharing
- Master/Slave current sharing
- AD02 has a special ESD protection mechanism that prevents the pin from pulling down the current-share bus if power is missing from the UCD3138A

The simplified current sharing circuitry is shown in the drawing below:

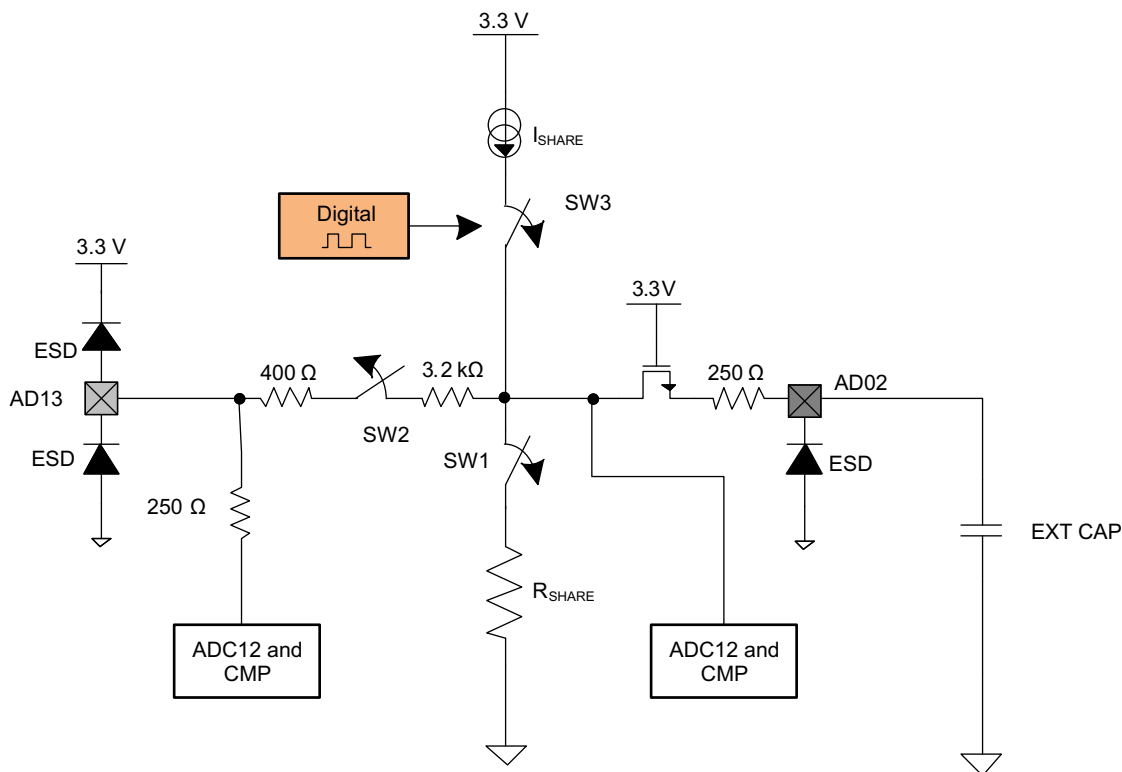

Figure 7-16. Simplified Current Sharing Circuitry

CURRENT SHARING MODE	FOR TEST ONLY, ALWAYS KEEP 00	CS_MODE	EN_SW1	EN_SW2	DPWM
Off or Slave Mode (3-state)	00	00 (default)	0	0	0
PWM Bus	00	01	1	0	ACTIVE
Off or Slave Mode (3-state)	00	10	0	0	0
Analog Bus or Master	00	11	0	1	0

The period and the duty of 8-bit PWM current source and the state of the SW1 and SW2 switches can be controlled through the current sharing control register (CSCTRL).

7.5.13 Temperature Reference

The temperature reference register (TEMPREF) provides the ADC12 count when ADC12 measures the internal temperature sensor (channel 14) during the factory trim and calibration.

This information can be used by different periodic temperature compensation routines implemented in the firmware. But it should not be overwritten by firmware, otherwise this factory written value is lost.

7.1 Device Functional Modes

The DPWM is a complex logic system which is highly configurable to support several different power supply topologies. This section discusses waveforms, timing, and register settings, rather than ON-logic design.

The DPWM functions using a period counter, which increments from 0 to PRD, then resets and begins to increment again.

The DPWM logic causes transitions in many digital signals when the period counter reaches the target value for that signal.

7.1.1 Normal Mode

In Normal mode, the Filter output determines the pulse width on DPWM A. DPWM B fits into the rest of the switching period, with a dead time separating it from the DPWM A on-time. It is useful for buck topologies. The drawing of the Normal Mode waveforms is shown in Figure 7-1.

Cycle adjust A can be used to adjust pulse widths on individual phases of a multi-phase system. This can be used for functions like current balancing. The Adaptive Sample Triggers can be used to sample in the middle of the on-time (for an average output), or at the end of the on-time (to minimize phase delay) The Adaptive Sample Register provides an offset from the center of the on-time. This can compensate for external delays, such as MOSFET and gate driver turn on times.

Blanking A-Begin and Blanking A-End can be used to blank out noise from the MOSFET turn on at the beginning of the period (DPWMA rising edge). Blanking B could be used at the turn off time of DPWMB. The other edges are dynamic, so blanking is more difficult.

Cycle Adjust B has no effect in Normal Mode.

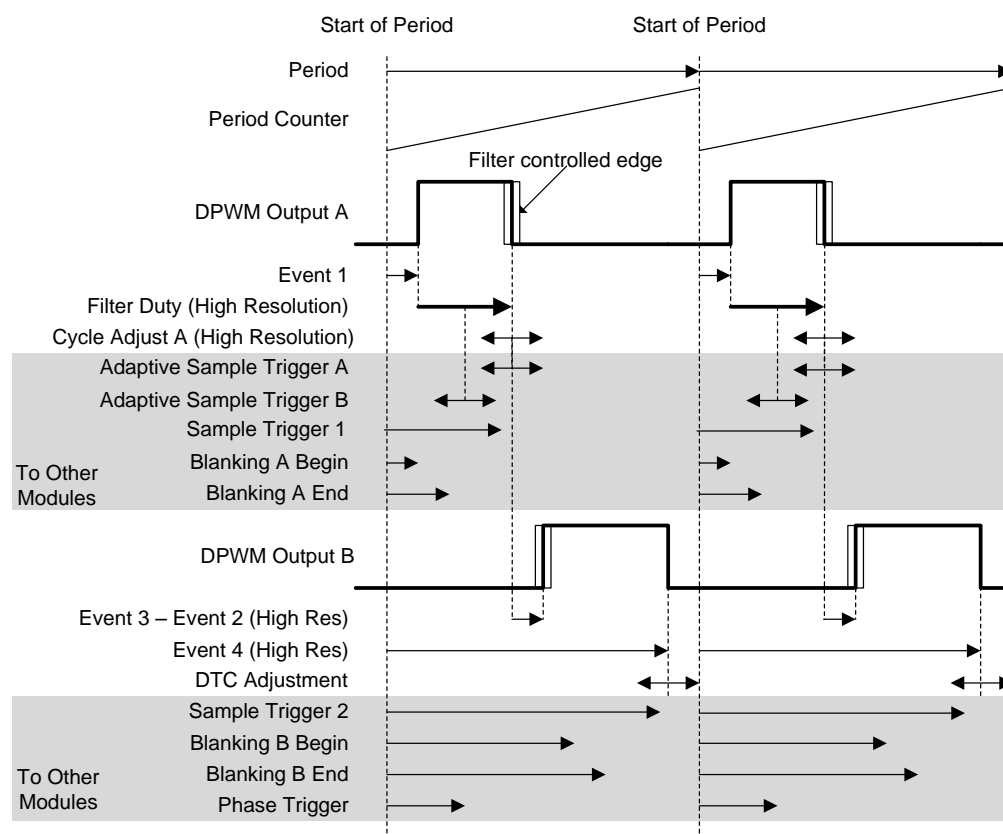

Events which change with DPWM mode:

- DPWM A Rising Edge = Event 1
- DPWM A Falling Edge = Event 1 + Filter Duty + Cycle Adjust A
- Adaptive Sample Trigger A = Event 1 + Filter Duty + Adaptive Sample Register or
- Adaptive Sample Trigger B = Event 1 + Filter Duty/2 + Adaptive Sample Register
- DPWM B Rising Edge = Event 1 + Filter Duty + Cycle Adjust A + (Event 3 – Event 2)
- DPWM B Falling Edge = Event 4 + DTC Adjustment
- Phase Trigger = Phase Trigger Register value or Filter Duty

Events always set by their registers, regardless of mode:

- Sample Trigger 1, Sample Trigger 2, Blanking A Begin, Blanking A End, Blanking B Begin, Blanking B End

Figure 7-1. Normal Mode Closed Loop

7.1.2 DPWM Multiple Output Mode

The device uses multi-mode functionality in systems where each phase has only one driver signal. It enables each DPWM peripheral to drive two phases with the same pulse width, but with a time offset between the phases, and with different cycle adjusts for each phase.

The diagram for Multi-Mode is shown in [Figure 7-2](#).

Event 2 and Event 4 are not relevant in Multi mode.

DPWMB can cross over the period boundary safely, and still have the proper pulse width, so full 100% pulse width operation is possible. DPWMA cannot cross over the period boundary.

Since the rising edge on DPWM B is also fixed, Blanking B-Begin and Blanking B-End can be used for blanking this rising edge.

Cycle Adjust B is usable on DPWM B.

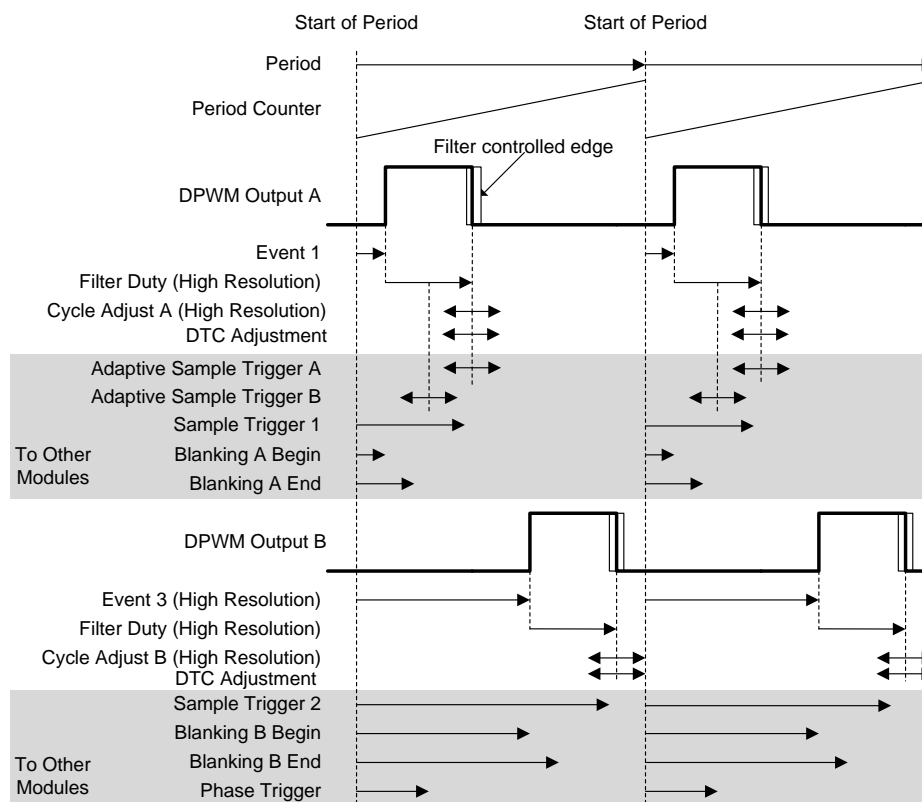

Events which change with DPWM mode:

- DPWM A Rising Edge = Event 1
- DPWM A Falling Edge = Event 1 + Filter Duty + Cycle Adjust A + DTC Adjustment
- Adaptive Sample Trigger A = Event 1 + Filter Duty + Adaptive Sample Register or
- Adaptive Sample Trigger B = Event 1 + Filter Duty/2 + Adaptive Sample Register
- DPWM B Rising Edge = Event 3
- DPWM B Falling Edge = Event 3 + Filter Duty + Cycle Adjust B + DTC Adjustment
- Phase Trigger = Phase Trigger Register value or Filter Duty

Events always set by their registers, regardless of mode:

- Sample Trigger 1, Sample Trigger 2, Blanking A Begin, Blanking A End, Blanking B Begin, Blanking B End

Figure 7-2. Multi Mode Closed Loop

7.1.3 DPWM Resonant Mode

This mode provides a symmetrical waveform where DPWMA and DPWMB have the same pulse width. As the switching frequency changes, the dead times between the pulses remain the same.

The equations for this mode are designed for a smooth transition from PWM mode to resonant mode, as described in [Section 7.5.2.2](#). The diagram of this mode is shown in [Figure 7-3](#).

The filter has two outputs, filter *duty* and filter *period*. In this case, the Filter is configured so that the filter period is twice the filter duty. So when there were no dead times, each DPWM pin in ON for half of the period. For dead-time handling, the device subtracts the average of the two dead times from the filter duty for both DPWM pins. Therefore, both pins have the same ON-time, and the dead times are fixed regardless of the period. The only edge which is fixed relative to the start of the period is the rising edge of DPWM A. This is the only edge for which the blanking signals can be used easily.

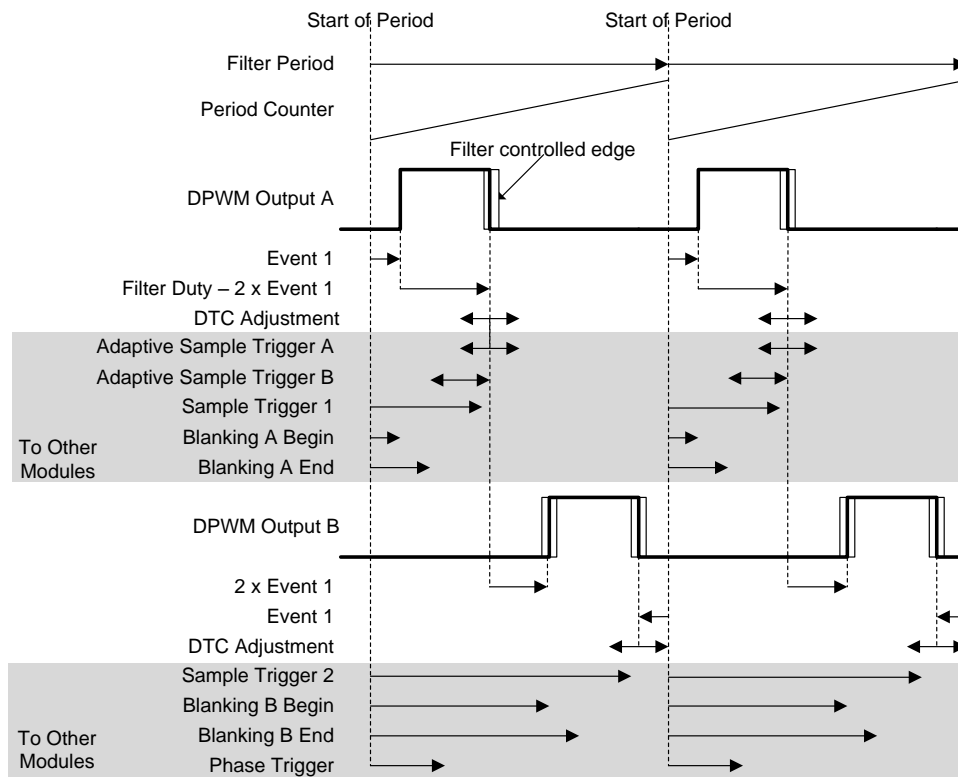

Events which change with DPWM mode:

- DPWM A Rising Edge = Event 1
- DPWM A Falling Edge = Filter Duty – Event 1
- Adaptive Sample Trigger A = Event 1 + Filter Duty + Adaptive Sample Register or
- Adaptive Sample Trigger B = Event 1 + Filter Duty/2 + Adaptive Sample Register
- DPWM B Rising Edge = Filter Duty + Event 1
- DPWM B Falling Edge = Filter Period – Event 1
- Phase Trigger = Phase Trigger Register value or Filter Duty

Events always set by their registers, regardless of mode:

- Sample Trigger 1, Sample Trigger 2, Blanking A Begin, Blanking A End, Blanking B Begin, Blanking B End
- Begin, Blanking B End

Figure 7-3. Resonant Symmetrical Closed Loop

7.1.4 Triangular Mode

Triangular mode provides a stable phase shift in interleaved PFC and similar topologies. In this case, the PWM pulse is centered in the middle of the period, rather than starting at one end or the other. In Triangular Mode, only DPWM-B is available. The diagram for Triangular Mode is shown in Figure 7-4.

All edges are dynamic in triangular mode, so fixed blanking is not that useful. The adaptive sample trigger is not needed. It is very easy to put a fixed sample trigger exactly in the center of the FET on-time, because the center of the on-time does not move in this mode.

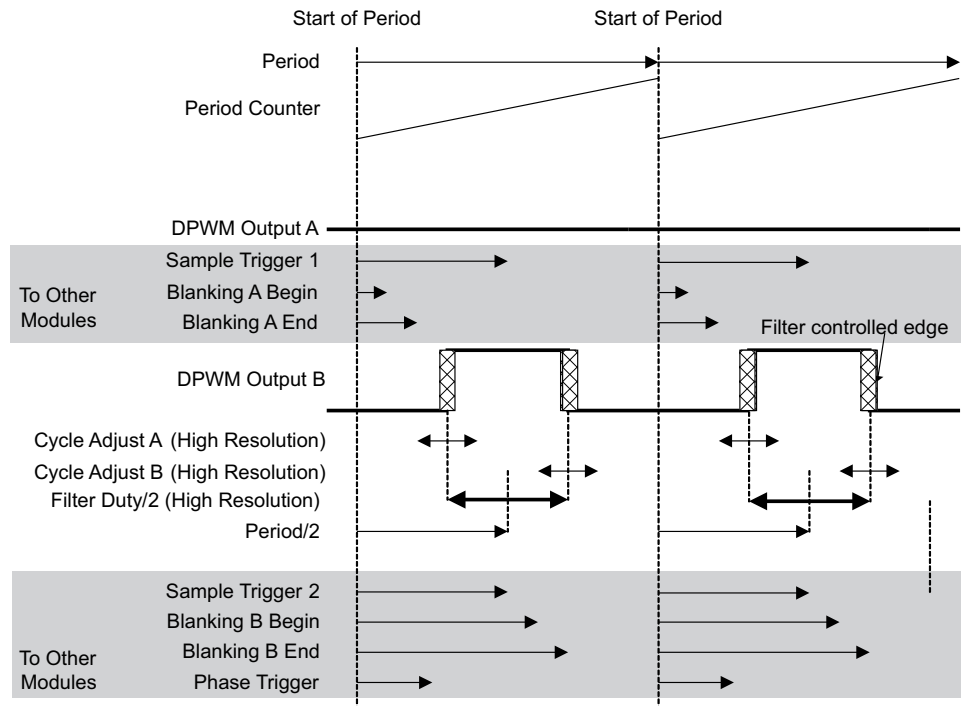

Events which change with DPWM mode:

- DPWM A Rising Edge = None
- DPWM A Falling Edge = None
- Adaptive Sample Trigger = None
- DPWM B Rising Edge = $\text{Period} / 2 - \text{Filter Duty} / 2 + \text{Cycle Adjust A}$
- DPWM B Falling Edge = $\text{Period} / 2 + \text{Filter Duty} / 2 + \text{Cycle Adjust B}$
- Phase Trigger = Phase Trigger Register value or Filter Duty

Events always set by their registers, regardless of mode:

- Sample Trigger 1, Sample Trigger 2, Blanking A Begin, Blanking A End, Blanking B Begin, Blanking B End

Figure 7-4. Triangular Mode Closed Loop

7.1.5 Leading Edge Mode

Leading edge mode is very similar to Normal mode, reversed in time. The DPWM A falling edge is fixed, and the rising edge moves to the left, or backwards in time, as the filter output increases. The DPWM B falling edge stays ahead of the DPWMA rising edge by a fixed dead time. The diagram of the Leading Edge Mode is shown in [Figure 7-5](#).

As in the Normal mode, the two edges in the middle of the period are dynamic, so the fixed blanking intervals are mainly useful for the edges at the beginning and end of the period.

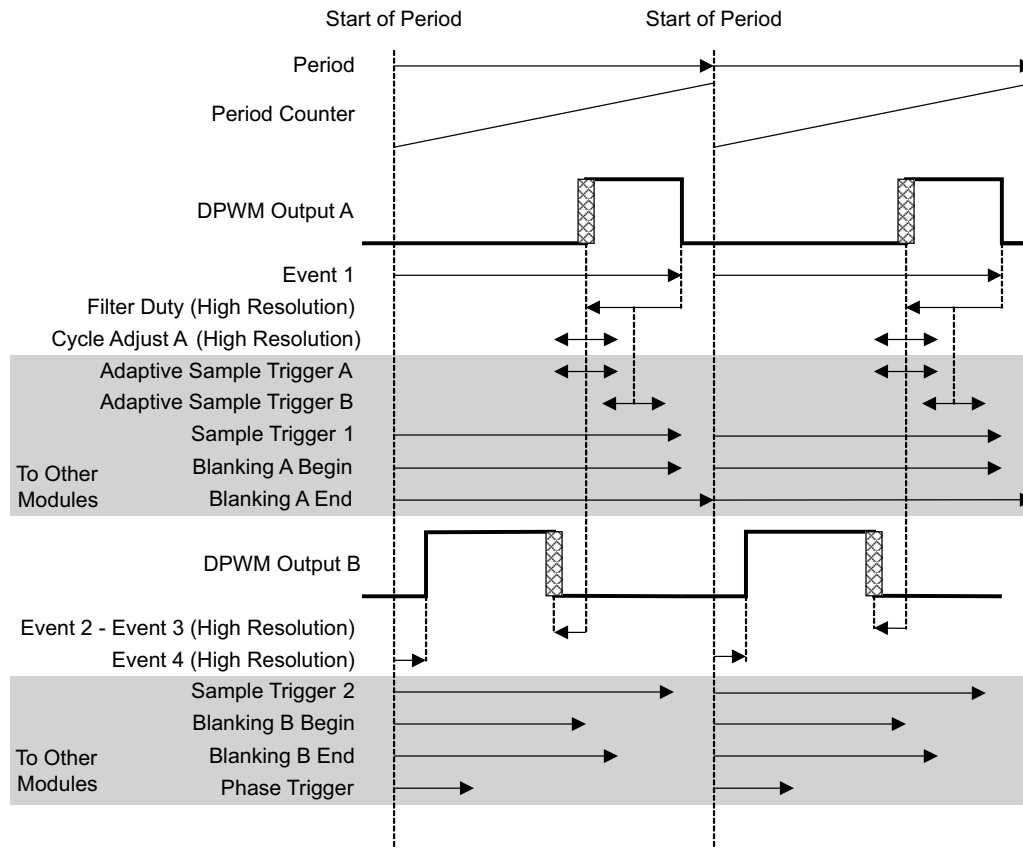

Events which change with DPWM mode:

- DPWM A Rising Edge = Event 1
- DPWM A Falling Edge = Event 1 - Filter Duty + Cycle Adjust A
- Adaptive Sample Trigger A = Event 1 - Filter Duty + Adaptive Sample Register or
- Adaptive Sample Trigger B = Event 1 - Filter Duty / 2 + Adaptive Sample Register
- DPWM B Rising Edge = Event 4
- DPWM B Falling Edge = Event 1 - Filter Duty + Cycle Adjust A - (Event 2 – Event 3)
- Phase Trigger = Phase Trigger Register value or Filter Duty

Events always set by their registers, regardless of mode:

- Sample Trigger 1, Sample Trigger 2, Blanking A Begin, Blanking A End, Blanking B Begin, Blanking B End
- Begin, Blanking B End

Figure 7-5. Leading Edge Closed Loop

8 Application and Implementation

NOTE

Information in the following applications sections is not part of the TI component specification, and TI does not warrant its accuracy or completeness. TI's customers are responsible for determining suitability of components for their purposes. Customers should validate and test their design implementation to confirm system functionality.

8.2 Application Information

The UCD3138A has an extensive set of fully-programmable, high-performance peripherals that make it suitable for a wide range of power supply applications. In order to make the part easier to use, TI has prepared an extensive set of materials to demonstrate the features of the device for several key applications. In each case the following items are available:

1. Full featured EVM hardware that demonstrates classic power supply functionality.
2. An EVM user guide that contains schematics, bill-of-materials, layout guidance and test data showcasing the performance and features of the device and the hardware.
3. A firmware programmers manual that provides a step-by-step walk through of the code.

Table 8-1. Application Information

APPLICATION	EVM DESCRIPTION
Phase shifted full bridge	This EVM demonstrates a PSFB DC-DC power converter with digital control using the UCD3138A device. Control is implemented by using PCMC with slope compensation. This simplifies the hardware design by eliminating the need for a series blocking capacitors and providing the inherent input voltage feed-forward that comes from PCMC. The controller is located on a daughter card and requires firmware in order to operate. This firmware, along with the entire source code, is made available through TI. A free, custom function GUI is available to help the user experiment with the different hardware and software enabled features. The EVM accepts a DC input from 350 VDC to 400 VDC, and outputs a nominal 12 VDC with full load output power of 360 W, or full output current of 30 A.
LLC resonant converter	This EVM demonstrates an LLC resonant half-bridge DC-DC power converter with digital control using the UCD3138A device. The controller is located on a daughter card and requires firmware in order to operate. This firmware, along with the entire source code, is made available through TI. A free, custom function GUI is available to help the user experiment with the different hardware and software enabled features. The EVM accepts a DC input from 350 VDC to 400 VDC, and outputs a nominal 12 VDC with full load output power of 340 W, or full output current of 29 A.

8.3 Typical Application

This section summarizes the PSFB EVM DC-DC power converter.

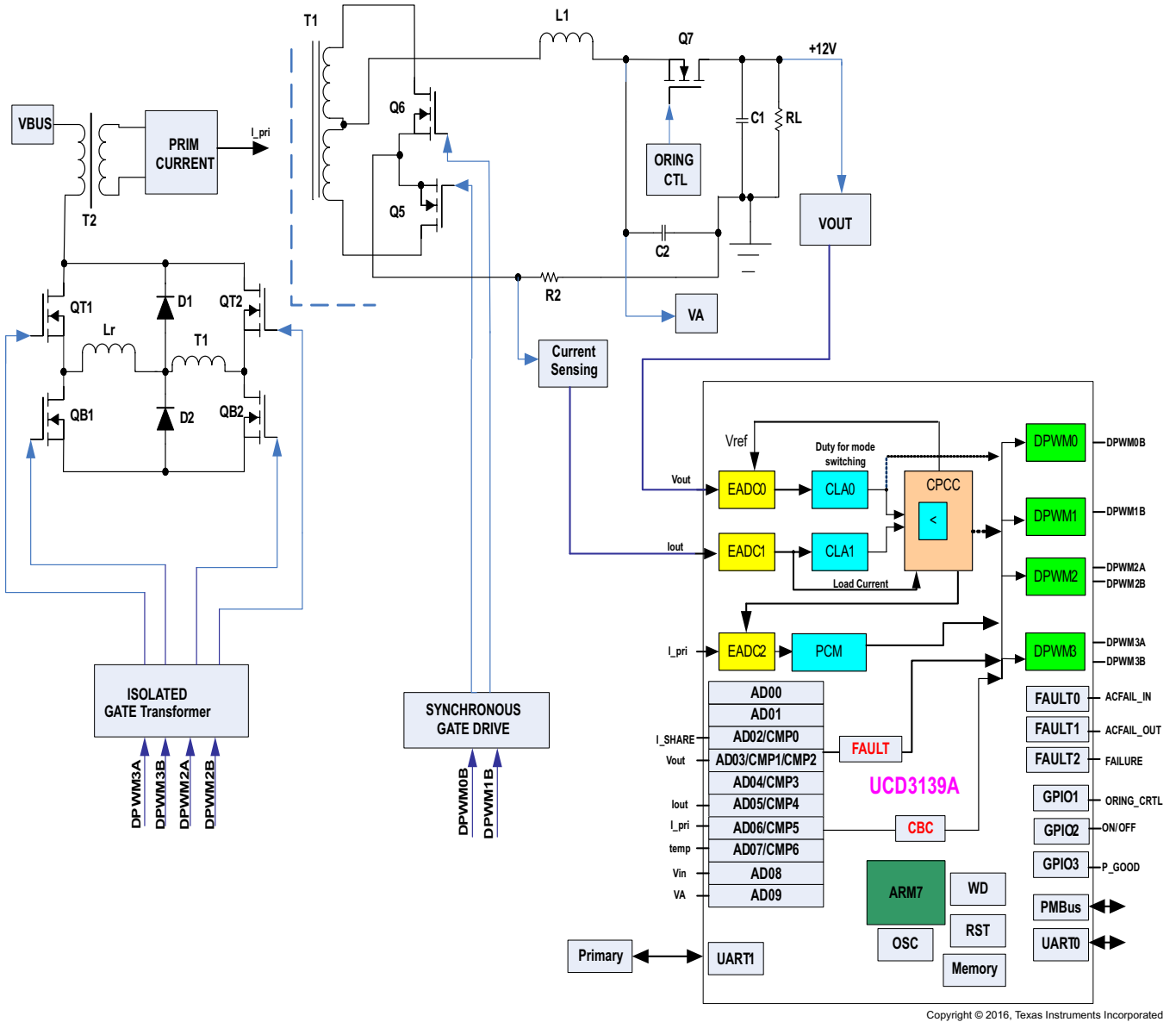

Figure 8-6. Phase-Shifted Full-Bridge Topology

8.3.1 Design Requirements

Table 8-2. Input Characteristics

PARAMETER		CONDITIONS	MIN	TYP	MAX	UNIT
ALL SPECIFICATIONS at $V_{in} = 400V$ and $25^{\circ}C$ AMBIENT UNLESS OTHERWISE NOTED.						
V_{in}	Input voltage range	Normal Operating	350	385	420	V
V_{inmax}	Max input voltage	Continuous			420	V
I_{in}	Input current	$V_{in} = 350V$, Full Load		1.15		A
I_{stby}	Input no load current	Output current is 0A		30		mA
V_{on}	Undervoltage lockout	V_{in} Decreasing (input voltage is detected on secondary side)		340		V
V_{hys}		V_{in} Increasing		360		V

Table 8-3. Output Characteristics

PARAMETER		CONDITIONS	MIN	TYP	MAX	UNIT
ALL SPECIFICATIONS at $V_{in} = 400V$ and $25^{\circ}C$ AMBIENT UNLESS OTHERWISE NOTED.						
V_O	Output voltage setpoint	No load on outputs		12		V
Reg_{line}	Line regulation	All outputs; $360 \leq V_{in} \leq 420$; $I_O = I_{Omax}$			0.5%	
Reg_{load}	Load regulation	All outputs; $0 \leq I_O \leq I_{Omax}$; $V_{in} = 400 V$			1%	
V_n	Ripple and noise ⁽¹⁾	5 Hz to 20 MHz		100		mVpp
I_O	Output current		0		30	A
η	Efficiency at phase-shift mode	$V_o = 12 V$, $I_o = 15 A$		93%		
η	Efficiency at PWM ZVS mode	$V_o = 12 V$, $I_o = 15 A$		93%		
η	Efficiency at hard switching mode	$V_o = 12 V$, $I_o = 15 A$		90%		
V_{adj}	Output adjust range		11.4		12.6	V
V_{tr}	Transient response overshoot/undershoot	50% load step at 1 μ S, min load at 2 A		± 0.36		V
$t_{settling}$	Transient response settling time			100		μ S
t_{start}	Output rise time	10% to 90% of V_{out}		50		mS
	Overshoot	At startup			2%	
f_s	Switching frequency	Over V_{in} and I_O ranges		150		kHz
I_{share}	Current sharing accuracy	50% - Full load		$\pm 5\%$		
ϕ	Loop phase margin	10% - Full load		45		$^{\circ}$
G	Loop gain margin	10% - Full load		10		dB

(1) Ripple and noise are measured with 10- μ F Tantalum capacitor and 0.1- μ F ceramic capacitor across output.

8.3.2 Detailed Design Procedure

8.3.2.1 PCMC (Peak Current Mode Control) PSFB (Phase-Shifted Full Bridge) Hardware Configuration Overview

The hardware configuration of the UCD3138A PCMC PSFB converter contains two critical elements that are highlighted in the [Section 8.3.2.2](#) and [Section 5.7.1.8](#) sections.

8.3.2.2 DPWM Initialization for PSFB

This section describes the key register settings and considerations necessary for the UCD3138A to generate the correct MOSFET waveforms for this topology. This maintains the proper phase relationship between the MOSFETs and synchronous rectifiers as well as the proper set up required to function correctly with PCMC.

The UCD3138A DPWM peripheral provides flexibility for a wide range of topologies. The PSFB configuration utilizes the Intra-Mux and Edge Generation Modules of the DPWM. For a diagram showing these modules, see the UCD3138A Digital Power Peripherals Manual.

Figure 8-7 shows the power stage of the PSFB.

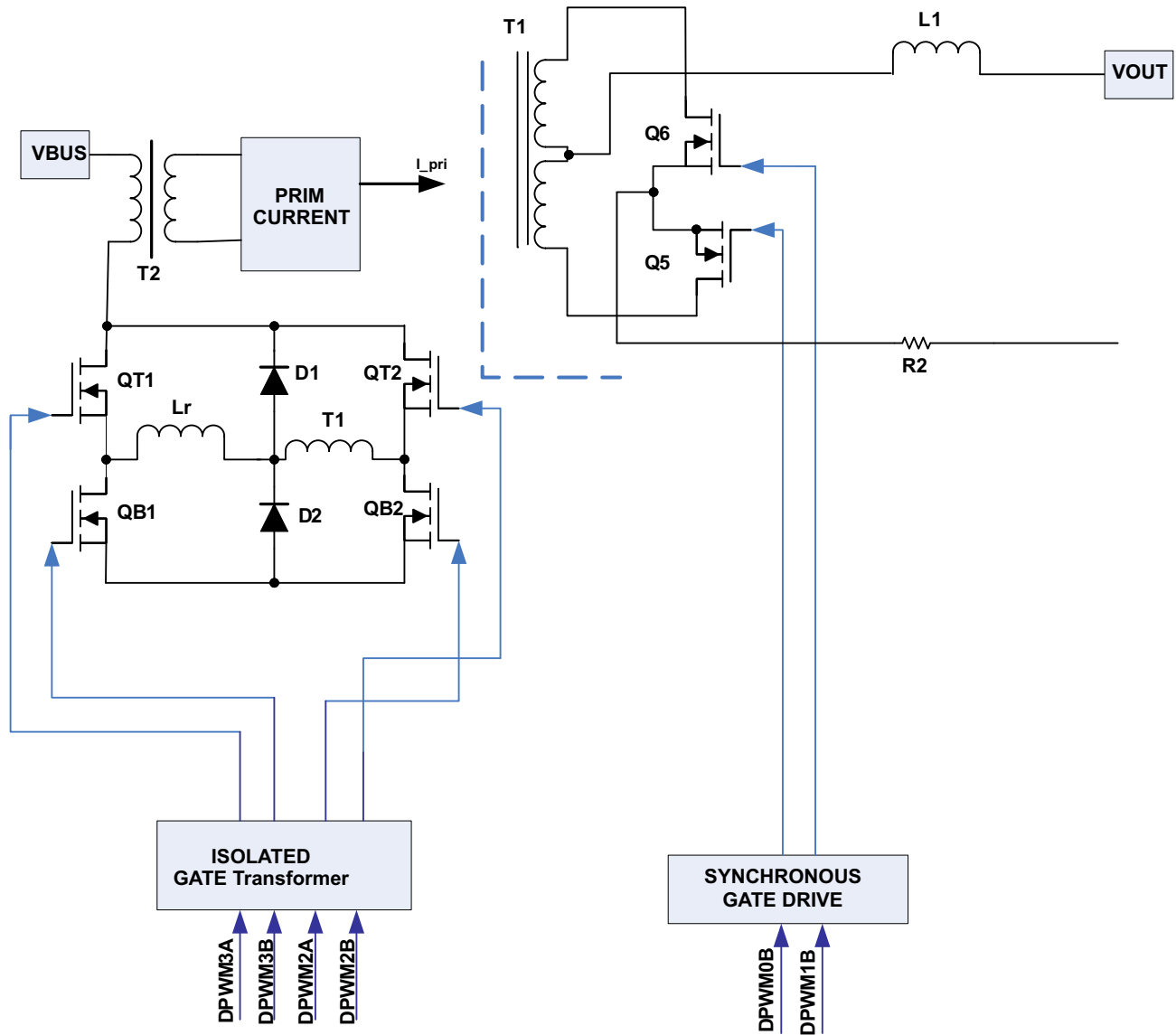
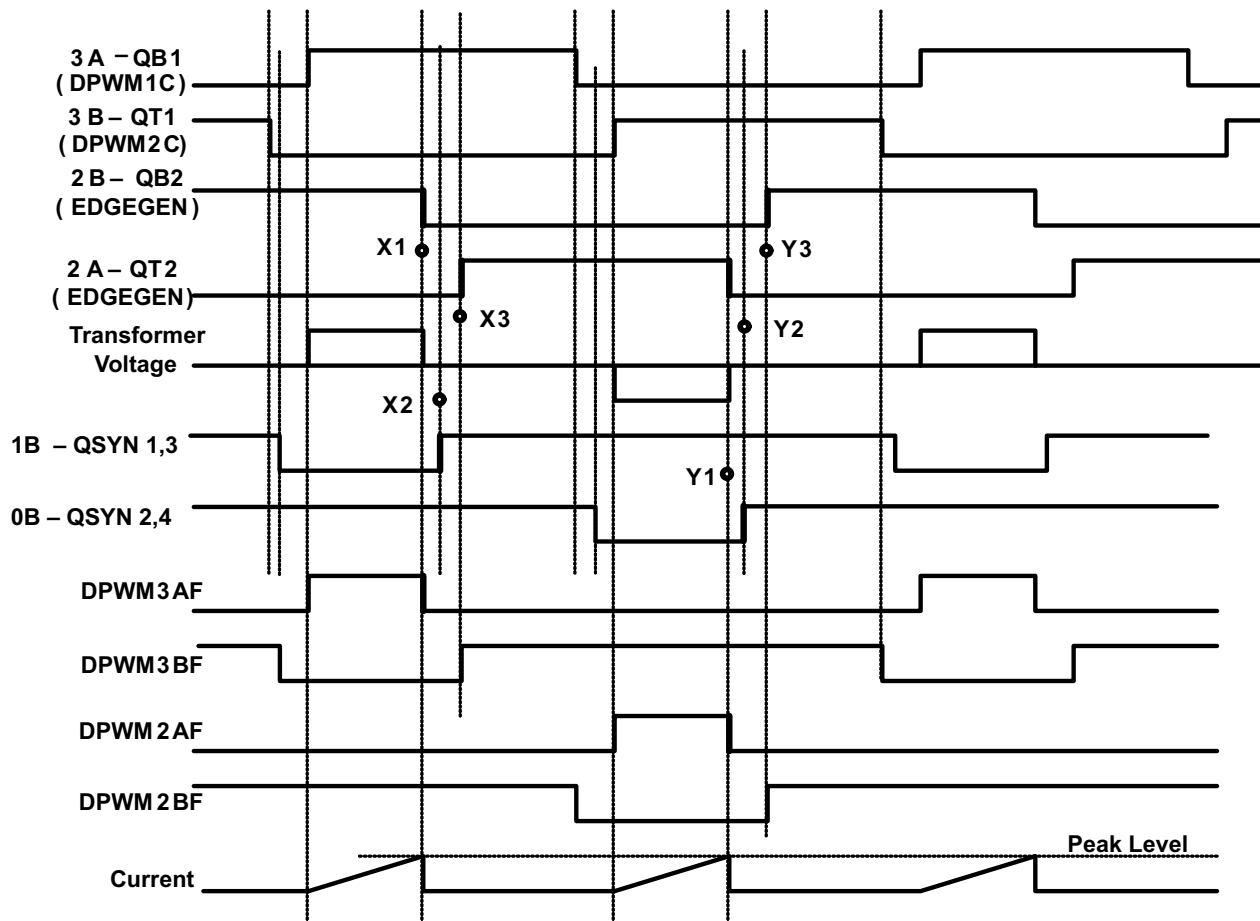

Figure 8-7. PSFB Power Stage Schematic

Figure 8-8 shows an overview of the key PSFB signals.



X 1 , X 2 , X 3 and Y 1 , Y 2 , Y 3 are sets of moving edges. All other edges are fixed

Figure 8-8. Key PSFB Signals

8.3.3 Fixed Signals to Bridge

The two top signals in Figure 8-8 have fixed timing. The DPWM1CF and DPWM2CF signals are used for these pins. DPWMCxF refers to the signal coming out of the fault module of DPWMx, as shown in Figure 8-9.

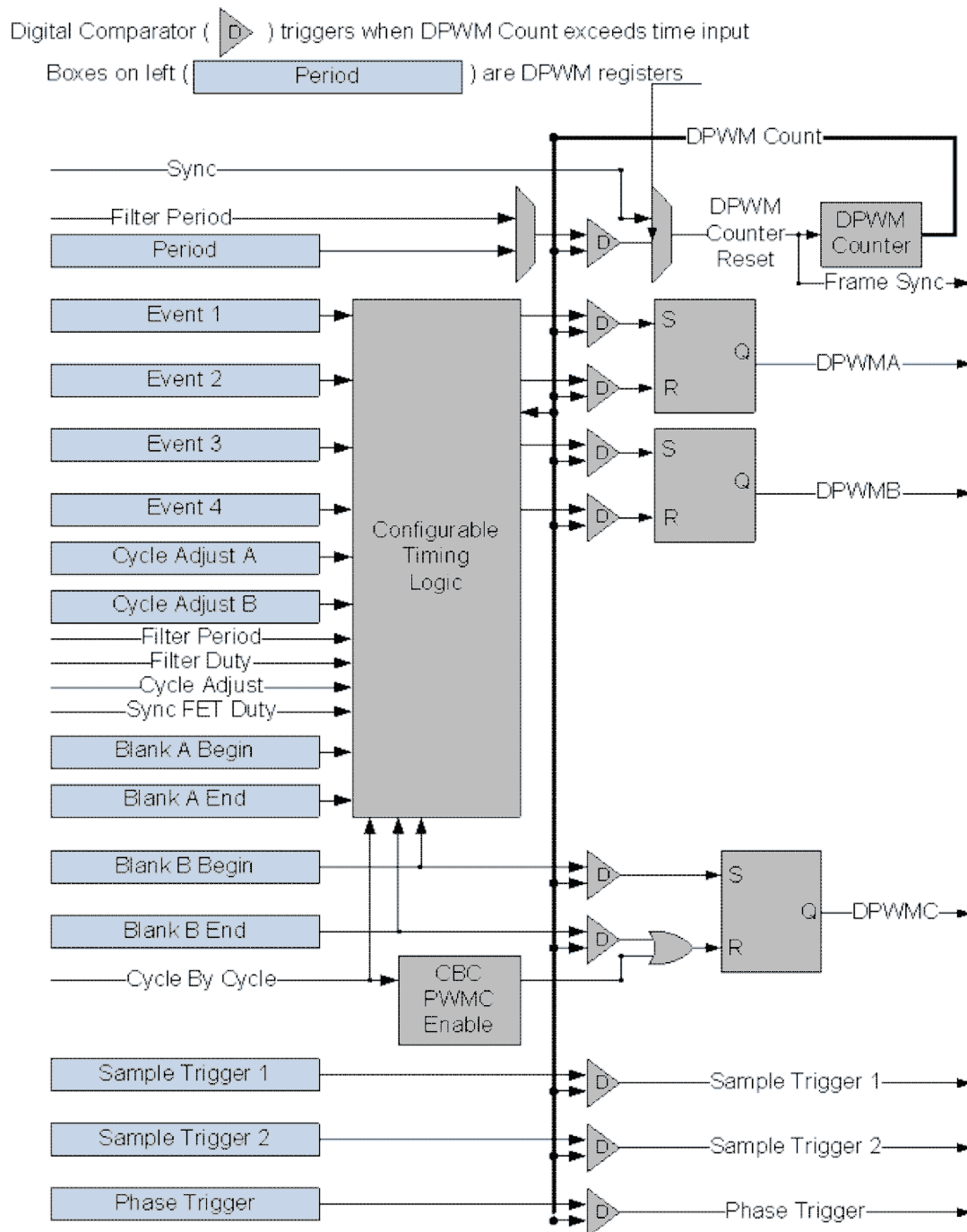

Figure 8-9. Fixed Signals to Bridge

These signals are actually routed to pins DPWM3A and 3B using the Intra Mux with these statements:

```
Dpwm3Regs.DPWMCTRL0.bit.PWM_A_INTRA_MUX = 7; // Send DPWM1C
Dpwm3Regs.DPWMCTRL0.bit.PWM_B_INTRA_MUX = 8; // Send DPWM2C
```

Since these signals are really being used as events in the timer, the #defines are called EV5 and EV6. Here are the statements which initialize them:

```
// Setup waveform for DPWM-C (re-using blanking B regs)
Dpwm2Regs.DPWMBLKBEG.all = PWM2_EV5 + (4 *16);
Dpwm2Regs.DPWMBLKBEND.all = PWM2_EV6;
```

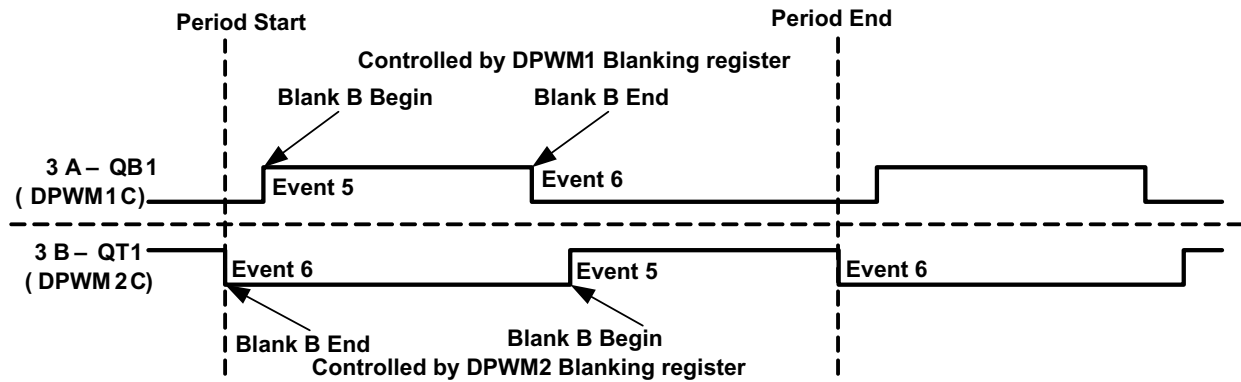

Figure 8-10. Blank B Timing Information

The statements for DPWM1 are the same. Remember that DPWMC reuses the Blank B registers for timing information.

8.3.4 Dynamic Signals to Bridge

DPWM0 and 1 are set at normal mode. PCMC triggering signal (fault) chops DPWM0A and 1A cycle by cycle. The corresponding DPWM0B and 1B are used for synchronous rectifier MOSFET control. The same PCMC triggering signal is applied to DPWM2 and DPWM3. Both of these are set to normal mode as well. DPWM2 and 3 are chopped and their edges are used to generate the next two dynamic signals to the bridge. They are generated using the Edge Generator Module in DPWM2. The Edge Generator sources are DPWM2 and DPWM3. The edges used are:

- DPWM2A turned on by a rising edge on DPWM2BF
- DPWM2A turned off by a falling edge on DPWM3AF
- DPWM2B turned on by a rising edge on DPWM3BF
- DPWM2B turned off by a falling edge on DPWM2AF

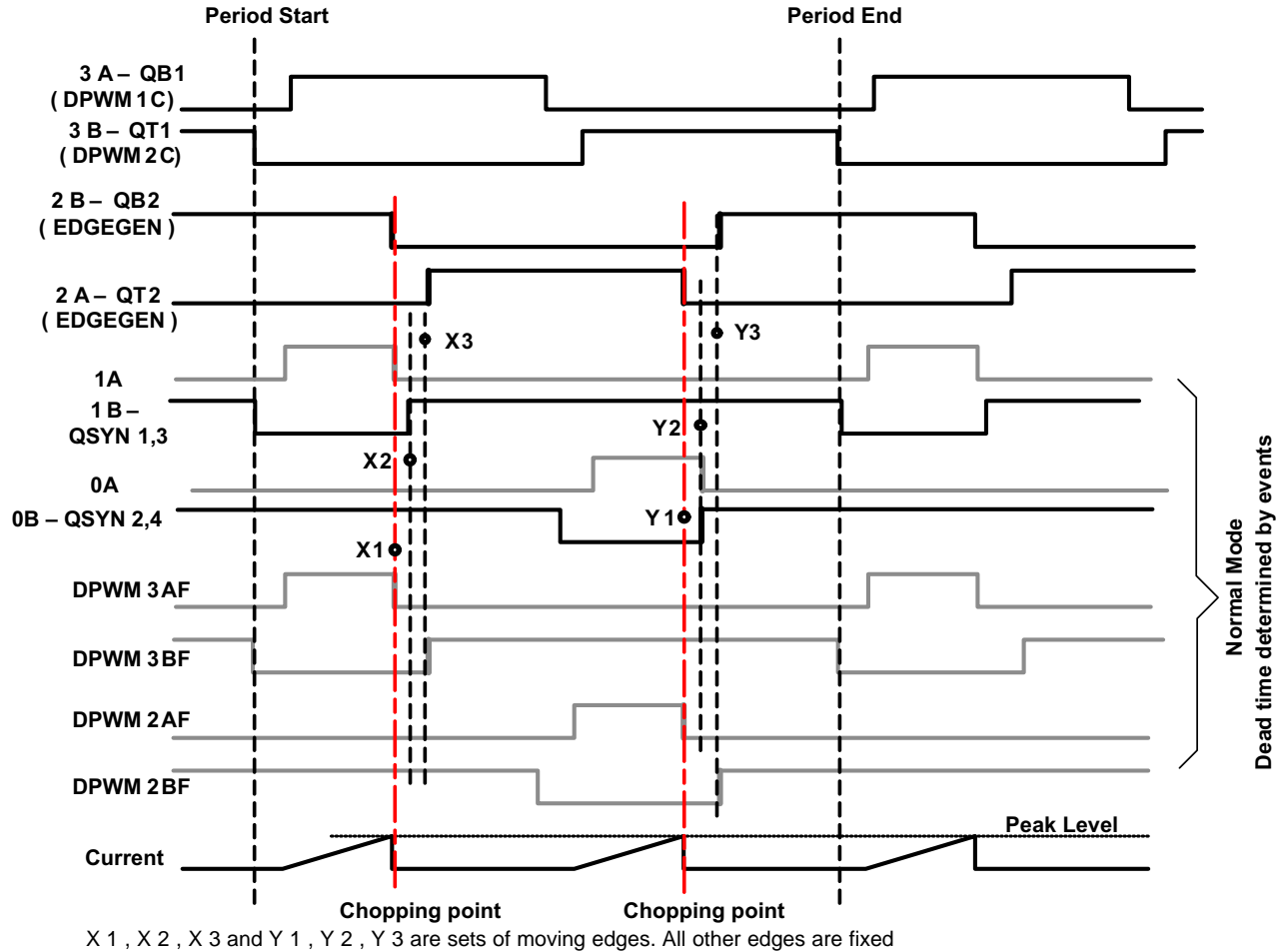

Figure 8-11. Dynamic Signals to Bridge

The Edge Generator is configured with these statements:

```
Dpwm2Regs.DPWMEDGEGEN.bit.A_ON_EDGE = 2;
Dpwm2Regs.DPWMEDGEGEN.bit.A_OFF_EDGE = 5;
Dpwm2Regs.DPWMEDGEGEN.bit.B_ON_EDGE = 6;
Dpwm2Regs.DPWMEDGEGEN.bit.B_OFF_EDGE = 1;
```

```
Dpwm2Regs.DPWMCTRL0.bit.PWM_A_INTRA_MUX = 1; // EDGEGEN-A out the A output
Dpwm2Regs.DPWMCTRL0.bit.PWM_B_INTRA_MUX = 1; // EDGEGEN-B out the B output
```

```
Dpwm2Regs.DPWMEDGEGEN.bit.EDGE_EN = 1;
```

The EDGE_EN bits are set for all 4 DPWMs. This is done to ensure that all signals have the same timing delay through the DPWM.

The final 6 gate signals are shown in [Figure 8-12](#).

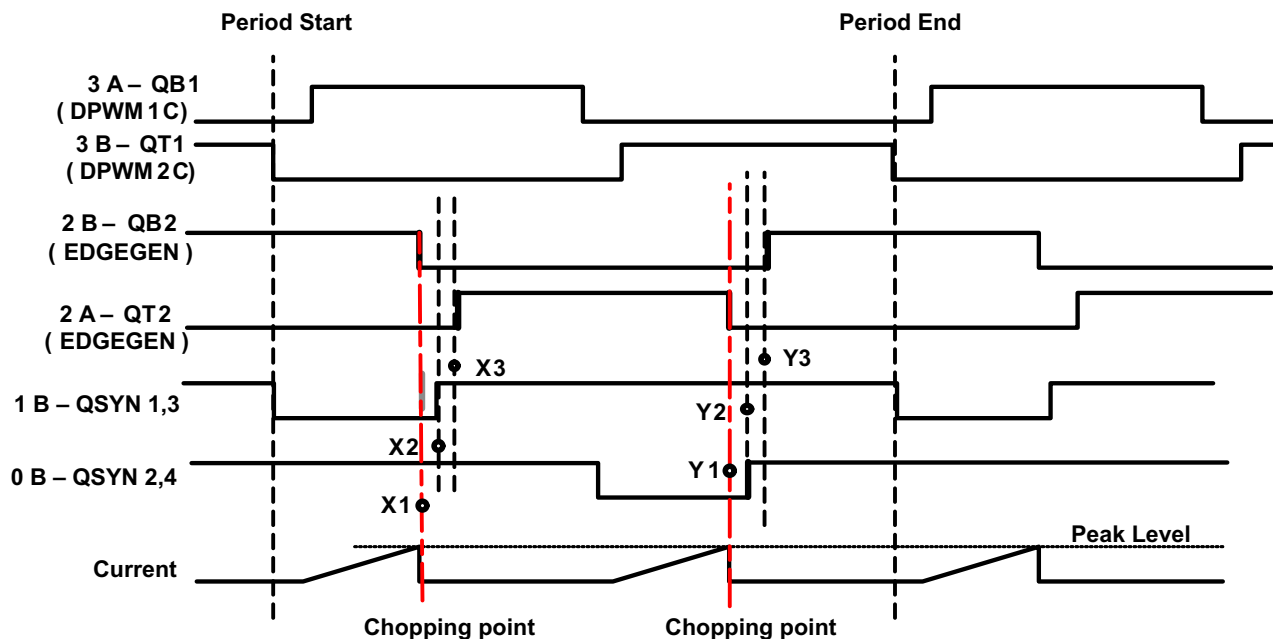

Figure 8-12. Final 6 Gate Signals

Note how the falling edge of DPWM2AF aligns with the X1 edge, and how the rising edge of DPWM2BF aligns with the X3 edge. The falling edges on DPWM2AF and DPWM3AF are caused by the peak detection logic. This is fed through the Cycle By Cycle logic. The Cycle By Cycle logic also has a special feature to control the rising edges of DPWM2BF (X1 and X3) and DPWM3BF (Y1 and Y3). It uses the value of Event3 – Event2 to control the time between the edges. The same feature is used with DPWM0 and DPWM1 to control the X2 and Y2 signals. Using the other 2 DPWMs permits these signals to have a different dead time.

The same setup can be used for voltage mode control. In this case, the Filter output sets the timing of the falling edge on DPWMxAF.

All DPWMs are configured in Normal mode, with CBC enabled. If external slope compensation is used, DPWM1A and DPWM1B are used to reset the external compensator at the beginning of each half cycle. If no PCMC event occurs, the values of Events 2 and 3 determine the locations of the edges, just as in open loop mode.

8.3.5 System Initialization for PCM

PCM (Peak Current Mode) is a specialized configuration for the UCD3138A which involves several peripherals. This section describes how it works across the peripherals.

8.3.5.1 Use of Front Ends and Filters in PSFB

All three front ends are used in PSFB. The same signals are used in the same places for both PCMC and voltage mode. The same hardware can be used for both control modes, with the mode determined by which firmware is loaded into the device. FE0 and FE1 are used with their associated filters, but Filter 2 is not used at all.

- FE0 – V_{OUT} – voltage loop
- FE1 – I_{OUT} – current loop
- FE2 – I_{PRI} – PCM

In PCMC mode, FE2 is used for PCMC, and the voltage loop is normally used to provide the start point for the compensation ramp. If the CPCC firmware detects a need for constant current mode, it switches to the current loop for the start point.

8.3.5.2 Peak Current Detection

Peak current detection involves all the major modules of the DPPs, the Front End, Filter, Loop Mux, Fault Mux and the DPWMs. A drawing of the major elements is shown in [Figure 8-13](#).

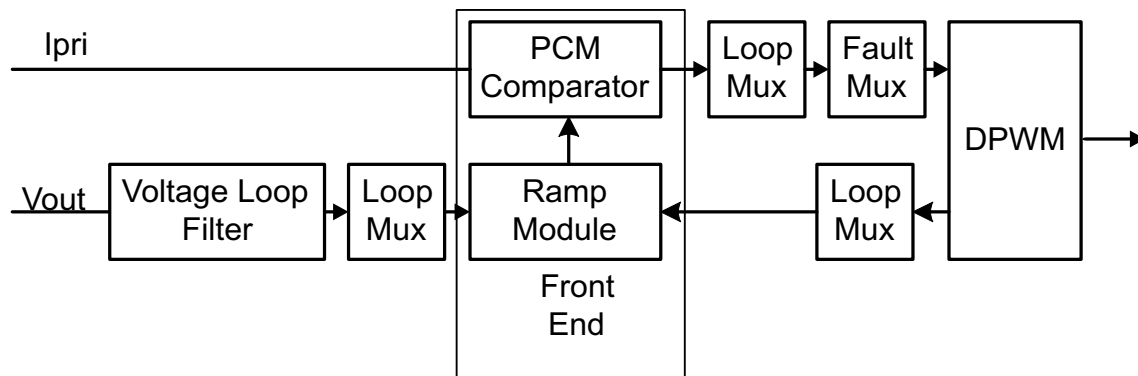

Figure 8-13. Peak Current Detection Function

The voltage loop is used to select a peak current level. This level is fed to the Ramp module to generate a compensation ramp. The compensation ramp is compared to the primary current by the PCMC comparator in the Front End. When the ramp value is greater than the primary current, the APCMC signal is sent to the DPWM, causing the events described in the previous sections.

The DPWM frame start and output pin signals can be used to trigger the Ramp Module. In this case, each DPWM frame triggers the start of the ramp. The ramp steps every 32 ns.

The PCM_FILTER_SEL bits in the LoopMux.PCMCTRL register are used to select which filter is connected to the ramp module:

```
LoopMuxRegs.PCMCTRL.bit.PCM_FILTER_SEL = 0; //select filter0
```

With Firmware Constant Power/Constant current, Filter 1 and Front End 1 are used as a current control loop, with the EADC DAC set to high current. If the voltage loop value becomes higher than the current loop value, then Filter 1 is used to control the PCM ramp start value:

```
LoopMuxRegs.PCMCTRL.bit.PCM_FILTER_SEL = 1;  
//select filter1 for slope compensation source
```

In the ramp module, there are 2 bitfields in the RAMPCTRL register which must be configured. The PCM_START_SEL must be set to a 1 to enable the Filter to be used as a ramp start source. The RAMP_EN bit must be set, of course.

The DAC_STEP register sets the slope of the compensation ramp. The DAC value is in volts, of course, so it is necessary to calculate the slope after the current to voltage conversion. Here is the formula for converting from millivolts per microsecond to DACSTEP.

m = compensation slope in millivolts per microsecond

$$ACSTEP = 335.5 \times M$$

In C, this can be written:

```
#define COMPENSATION_SLOPE 150 //compensation slope in millivolts per microsecond  
#define DACSTEP_COMP_VALUE ((int) (COMPENSATION_SLOPE*335.5) )  
//value in DACSTEP for desired compensation slope
```

```
FeCtrl0Regs.DACSTEP.all = DACSTEP_COMP_VALUE;
```

It may also be necessary to set a ramp ending value in the RAMPDACEND register.

In addition, it is necessary to set the D2S_COMP_EN bit in the EADCCTRL register. This is for enabling the differential to single ended comparator function. The front end diagram leaves it out for simplicity, but the connection between the DAC and the EADC amplifier is actually differential. The PCMC comparator, however, is single ended. So a conversion is necessary as shown in Figure 8-14.

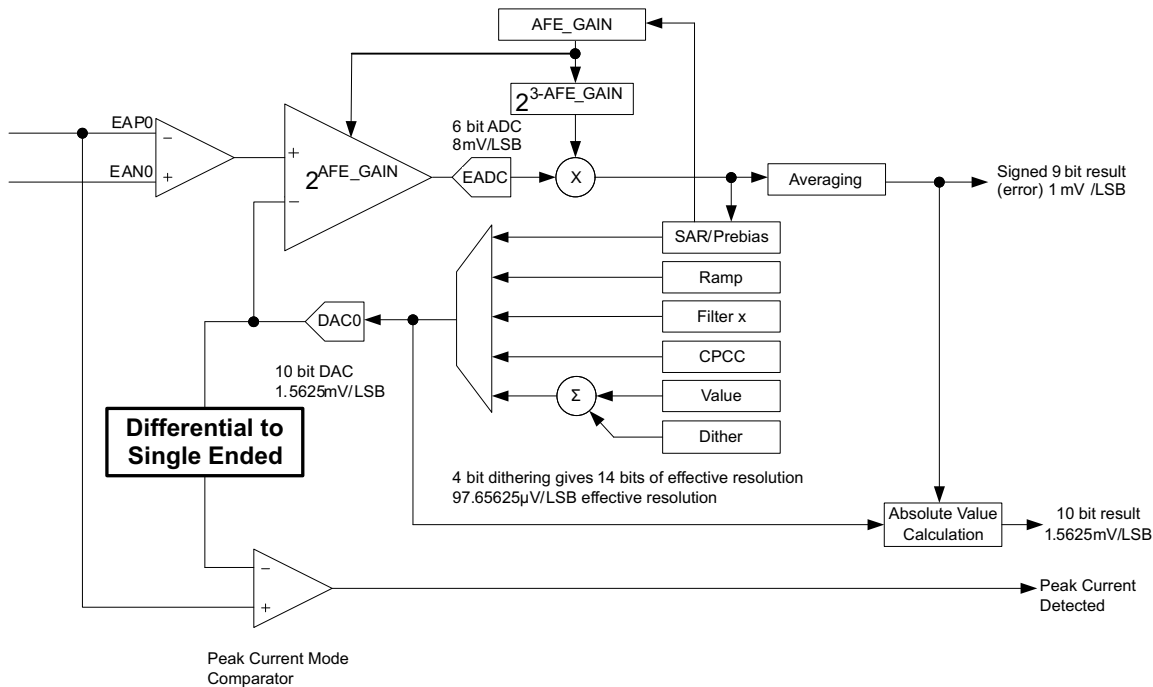

Figure 8-14. Differential to Single-Ended Comparator Function

The EADC_MODE bit in EADCCTRL should be set to a 5 for peak current mode.

The peak current detection signal next goes to the Loop Mux. The Fault Mux has only 1 APCM input, but there are 3 front ends. So the PCM_FE_SEL bits in APCMCTRL must be used to select which front end is used:

LoopMuxRegs.APCMCTRL.bit.PCM_FE_SEL = 2; // use FE2 for PCM */

The PCM_EN bit must also be set.

LoopMuxRegs.APCMCTRL.bit.PCM_EN = 1; // Enable PCM

Next the Fault Mux is used to enable the APCM bit to the CLIM/CBC signal to the DPWM. There are 4 DPWMxCLIM registers, one for each DPWM. The ANALOG_PCM_EN bit must be set in each one to connect the PCM detection signal to the CLIM/CBC signal on each DPWM. For the latest configuration information on all of these bits, consult the appropriate EVM firmware. To avoid errors, it is best to configure your hardware design using the same DPWMs, filters, and front ends for the same functions as the EVM.

DPWM timing is used to trigger the start of the ramp. This is selected by the FECTRLxMUX registers in the Loop Mux. DPWMx_FRAME_SYNC_EN bits, when set, cause the ramp to be triggered at the start of the DPWM period.

8.3.5.3 Peak Current Mode (PCM)

There is one peak current mode control module in the device however any front end can be configured to use this module.

8.3.6 Application Curves

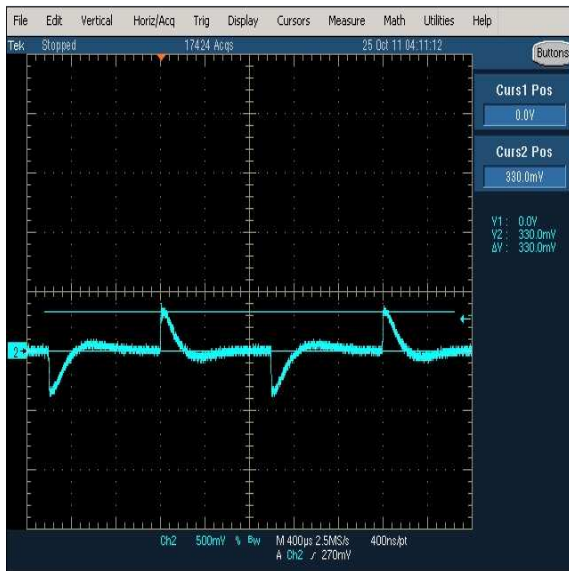

Transient 1 A to 16 A to 1 A $V_{IN} = 385 V$

Figure 8-15. Load Transient

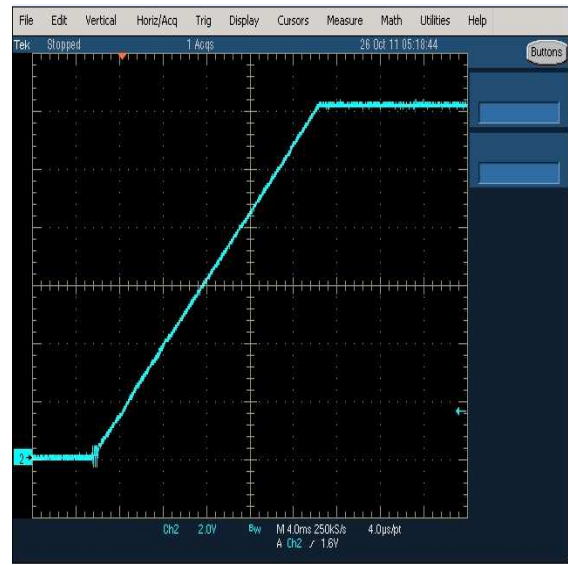

$I_{LOAD} = 30 A$ syncFETs off

Figure 8-16. V_{OUT} Soft Start

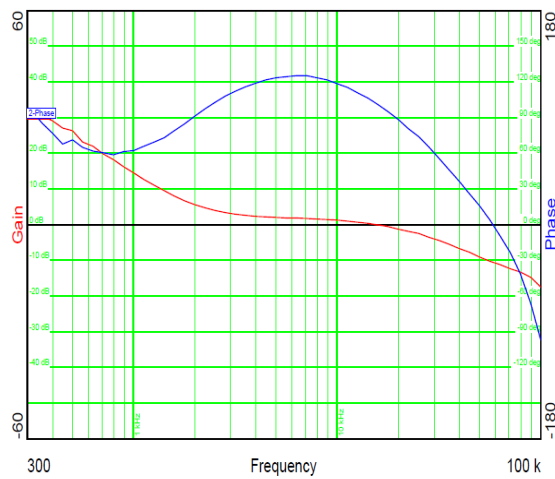

$K_p = 14000$ $K_d = 2000$
 $K_i = 300$ $\text{Alpha} = -2$

Figure 8-17. Bode Plot

9 Power Supply Recommendations

9.1 Power Supply Decoupling and Bulk Capacitors

- Both 3.3 VD and 3.3 VA should have a local 4.7- μ F capacitor placed as close as possible to the device pins.
- BP18 should have a 1- μ F capacitor.

10 Layout

10.1 Layout Guidelines

- Single ground is recommended: SGND. A multilayer such as 4 layers board is recommended so that one solid SGND is dedicated for return current path, referred to the layout example.
- Apply multiple different capacitors for different frequency range on decoupling circuits. Each capacitor has different ESL, Capacitance and ESR, and they have different frequency response.
- Avoid long traces close to radiation components, and place them into an internal layer, and it is preferred to have grounding shield, and in the end, add a termination circuit;
- Analog circuit such as ADC sensing lines needs a return current path into the analog circuitry; digital circuit such as GPIO, PMBus and PWM has a return current path into the digital circuitry; although with a single plane, still try to avoid to mix analog current and digital current.
- Don't use a ferrite bead or larger than 3- Ω resistor to connect between V33A and V33D.
- Both 3.3VD and 3.3VA should have local 4.7- μ F decoupling capacitors close to the device power pins, add visas to connect decoupling caps directly to SGND.
- Avoid negative current/negative voltage on all pins, so Schottky diodes may need to clamp the voltage; avoid the voltage spike on all pins more than 3.8 V or less than -0.3 V, add Schottky diodes on the pins which could have voltage spikes during surge test; be aware that a Schottky has relatively higher leakage current, which can affect the voltage sensing at high temperature.
- If V33 slew rate is less than 2.5 V/ms the RESET pin should have a 2.21-k Ω resistor between the reset pin and V33D and a 2.2- μ F capacitor from RESET to ground. For more details please refer to the [UCD3138 Family - Practical Design Guideline](#) This capacitor must be located close to the device RESET pin.
- 2.2 μ F between V33D and BP18 can be removed due to internal enhancement design.
- Configure unused GPIO pins to be inputs or connect them to the ground (DGND or SGND). For detailed practical design guideline refer to [UCD3138 Family - Practical Design Guideline](#)

10.2 Layout Example

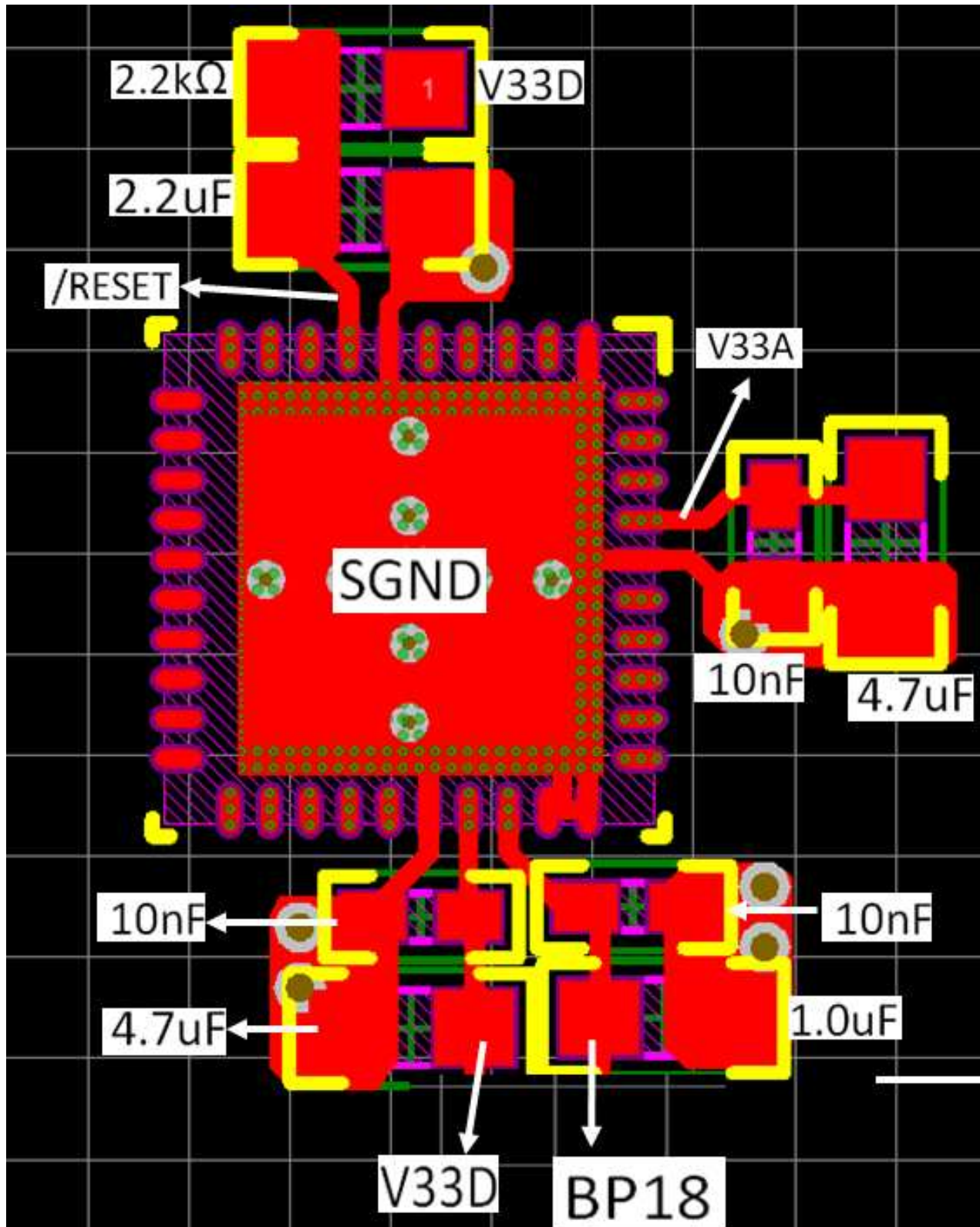

Figure 10-1. UCD3138A Layout Example

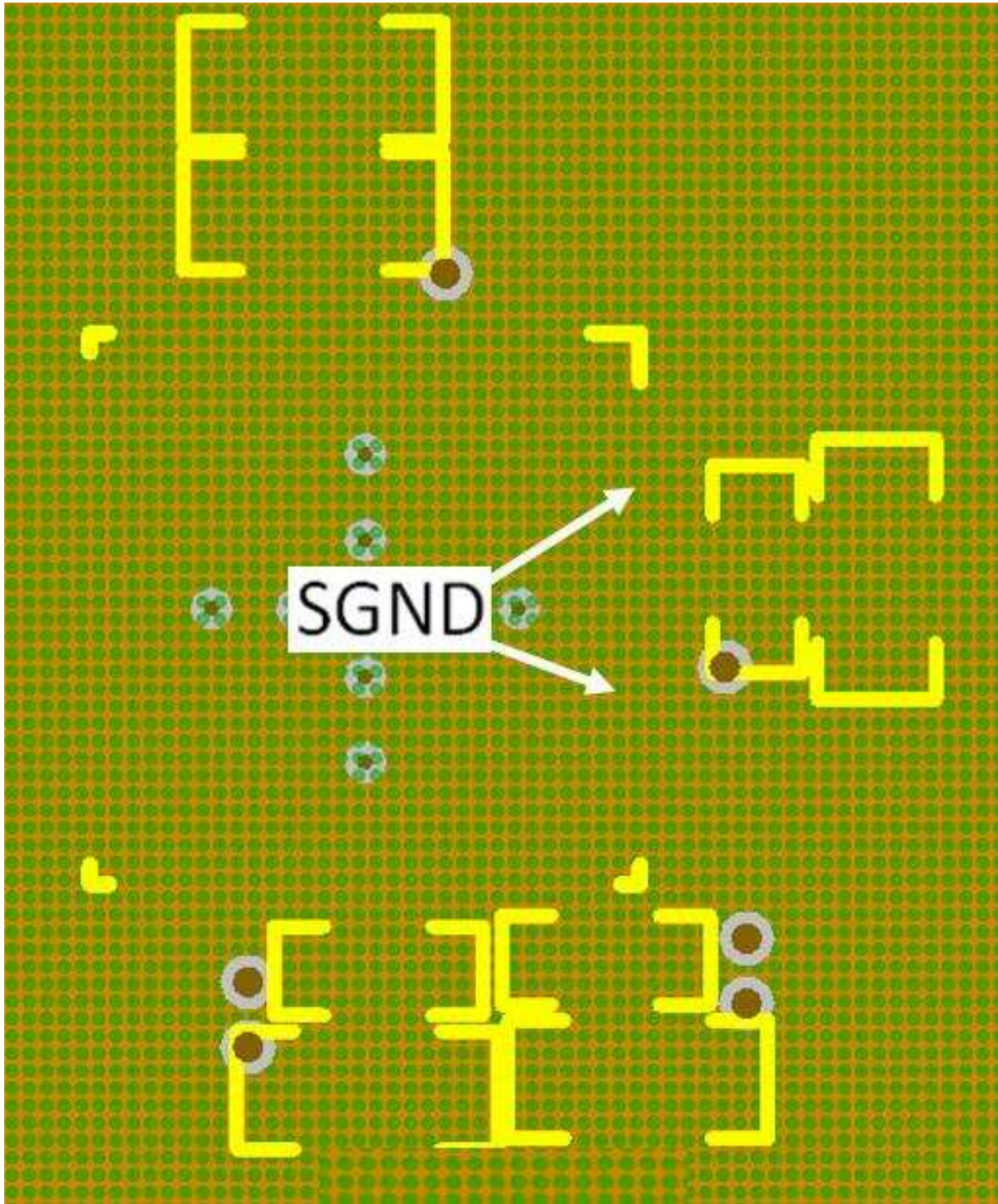

Figure 10-2. UCD3138A Layout Example, Internal Plane

11 Device and Documentation Support

11.1 Device Support

11.1.1 Development Support

TI offers an extensive line of development tools, including tools to evaluate the performance of the processors, generate code, develop algorithm implementations, and fully integrate and debug software and hardware modules. The tool's support documentation is electronically available within the Code Composer Studio™ Integrated Development Environment (IDE).

The following products support development of the *your device* device applications:

Software Development Tools: Code Composer Studio™ Integrated Development Environment (IDE): including Editor C/C++/Assembly Code Generation, and Debug plus additional development tools Scalable, Real-Time Foundation Software (DSP/BIOS™), which provides the basic run-time target software needed to support any *your device* device application.

Hardware Development Tools: Extended Development System (XDS™) Emulator

For a complete listing of development-support tools for the *your device* platform, visit the Texas Instruments website at www.ti.com. For information on pricing and availability, contact the nearest TI field sales office or authorized distributor.

11.1.1.1 Tools and Documentation

The application firmware for UCD3138A is developed on Texas Instruments Code Composer Studio (CCS) integrated development environment (v6.x recommended).

Device programming, real time debug and monitoring/configuration of key device parameters for certain power topologies are all available through the TI [FUSION_DIGITAL_POWER_DESIGNER](#) software.

The FUSION_DIGITAL_POWER_DESIGNER software uses the PMBus protocol to communicate with the device over a serial bus using an interface adaptor known as the [USB-TO-GPIO](#), available as an EVM from Texas Instruments. PMBus-based real-time debug capability is available through the *Memory Debugger* tool within the Device GUI module of the FUSION_DIGITAL_POWER_DESIGNER GUI, which represents a powerful alternative over traditional JTAG-based approaches.

The software application can also be used to program the devices, with a version of the tool known as [FUSION_MFR_GUI](#) optimized for manufacturing environments. The FUSION_MFR_GUI tool supports multiple devices on a board, and includes built-in logging and reporting capabilities.

Programmer manuals are available offering detailed information regarding the application and usage of UCD3138A digital controller:

1. UCD3138A Digital Power Peripheral Programmer's Manual Key topics covered in this manual include:
 - Digital Pulse Width Modulator (DPWM)
 - Modes of Operation (Normal/Multi/Phase-shift/Resonant and so forth)
 - Automatic Mode Switching
 - DPWMC, Edge Generation and Intra-Mux
 - Front End
 - Analog Front End
 - Error ADC or EADC
 - Front End DAC
 - Ramp Module
 - Successive Approximation Register Module
 - Filter
 - Filter Math
 - Loop Mux
 - Analog Peak Current Mode

- Constant Current/Constant Power (CCCP)
 - Automatic Cycle Adjustment
 - Fault Mux
 - Analog Comparators
 - Digital Comparators
 - Fault Pin functions
 - DPWM Fault Action
 - Ideal Diode Emulation (IDE), DCM Detection
 - Oscillator Failure Detection
 - Register Map for all of the above peripherals in UCD3138A
2. UCD3138A Monitoring and Communications Programmer's Manual
Key topics covered in this manual include:
- ADC12
 - Control, Conversion, Sequencing & Averaging
 - Digital Comparators
 - Temperature Sensor
 - PMBUS Addressing
 - Dual Sample and Hold
 - Miscellaneous Analog Controls (Current Sharing, Brown-Out, Clock-Gating)
 - PMBUS Interface
 - General Purpose Input Output (GPIO)
 - Timer Modules
 - PMBus
 - Register Map for all of the above peripherals in UCD3138A
3. UCD3138A ARM and Digital System Programmer's Manual
Key topics covered in this manual include:
- Boot ROM and Boot Flash
 - BootROM Function
 - Memory Read/Write Functions
 - Checksum Functions
 - Flash Functions
 - Avoiding Program Flash Lock-Up
 - ARM7 Architecture
 - Modes of Operation
 - Hardware/Software Interrupts
 - Instruction Set
 - Dual State Inter-working (Thumb 16-bit Mode/ARM 32-bit Mode)
 - Memory and System Module
 - Address Decoder, DEC (Memory Mapping)
 - Memory Controller (MMC)
 - Central Interrupt Module
 - Register Map for all of the above peripherals in UCD3138A
4. FUSION_DIGITAL_POWER_DESIGNER for Isolated Power Applications
- User guide for Designer GUI
 - User guide for Device GUI
 - Firmware Memory Debugger
 - Manufacturing Tool (MFR GUI)

In addition to the tools and documentation described above, for the most up to date information regarding evaluation modules, reference application firmware and application notes/design tips, please visit <http://www.ti.com/product/UCD3138A>.

11.2 Documentation Support

11.2.1 References

1. [UCD3138A Digital Power Peripherals Programmer's Manual](#)
2. [UCD3138A Monitoring and Communications Programmer's Manual](#)
3. [UCD3138A ARM and Digital System Programmer's Manual](#)
4. [FUSION_DIGITAL_POWER_DESIGNER for Isolated Power Applications](#)
5. [Code Composer Studio Development Tools v3.3 – Getting Started Guide](#)
6. [ARM7TDMI-S Technical Reference Manual](#)
7. [System Management Bus \(SMBus\) Specification](#)
8. [PMBus™ Power System Management Protocol Specification](#)

11.3 Receiving Notification of Documentation Updates

To receive notification of documentation updates, navigate to the device product folder on ti.com. In the upper right corner, click on *Alert me* to register and receive a weekly digest of any product information that has changed. For change details, review the revision history included in any revised document.

11.4 Community Resources

The following links connect to TI community resources. Linked contents are provided "AS IS" by the respective contributors. They do not constitute TI specifications and do not necessarily reflect TI's views; see TI's [Terms of Use](#).

TI E2E™ Online Community The TI engineer-to-engineer (E2E) community was created to foster collaboration among engineers. At e2e.ti.com, you can ask questions, share knowledge, explore ideas and help solve problems with fellow engineers.

Design Support TI's Design Support Quickly find helpful E2E forums along with design support tools and contact information for technical support.

11.5 Trademarks

Code Composer Studio, Fusion Digital Power, E2E are trademarks of Texas Instruments.

ARM7TDMI-S is a trademark of ARM.

PMBus is a trademark of SMIF, Inc..

All other trademarks are the property of their respective owners.

11.6 Electrostatic Discharge Caution



This integrated circuit can be damaged by ESD. Texas Instruments recommends that all integrated circuits be handled with appropriate precautions. Failure to observe proper handling and installation procedures can cause damage.

ESD damage can range from subtle performance degradation to complete device failure. Precision integrated circuits may be more susceptible to damage because very small parametric changes could cause the device not to meet its published specifications.

11.7 Glossary

TI Glossary This glossary lists and explains terms, acronyms, and definitions.

12 Mechanical Packaging and Orderable Information

12.1 Packaging Information

The following pages include mechanical packaging and orderable information. This information is the most current data available for the designated devices. This data is subject to change without notice and revision of this document. For browser-based versions of this data sheet, refer to the left-hand navigation.

PACKAGING INFORMATION

Orderable Device	Status (1)	Package Type	Package Drawing	Pins	Package Qty	Eco Plan (2)	Lead/Ball Finish (6)	MSL Peak Temp (3)	Op Temp (°C)	Device Marking (4/5)	Samples
UCD3138ARGCR	ACTIVE	VQFN	RGC	64	2000	Green (RoHS & no Sb/Br)	CU NIPDAU	Level-2-260C-1 YEAR	-40 to 125	UCD3138A	Samples
UCD3138ARGCT	ACTIVE	VQFN	RGC	64	250	Green (RoHS & no Sb/Br)	CU NIPDAU	Level-2-260C-1 YEAR	-40 to 125	UCD3138A	Samples
UCD3138ARJAR	ACTIVE	VQFN	RJA	40	3000	Green (RoHS & no Sb/Br)	CU NIPDAUAG	Level-2-260C-1 YEAR	-40 to 125	UCD3138A	Samples
UCD3138ARJAT	ACTIVE	VQFN	RJA	40	250	Green (RoHS & no Sb/Br)	CU NIPDAUAG	Level-2-260C-1 YEAR	-40 to 125	UCD3138A	Samples
UCD3138ARMHR	NRND	WQFN	RMH	40	2000	Green (RoHS & no Sb/Br)	CU NIPDAU	Level-2-260C-1 YEAR	-40 to 125	UCD3138A	
UCD3138ARMHT	NRND	WQFN	RMH	40	250	Green (RoHS & no Sb/Br)	CU NIPDAU	Level-2-260C-1 YEAR	-40 to 125	UCD3138A	

(1) The marketing status values are defined as follows:

ACTIVE: Product device recommended for new designs.

LIFEBUY: TI has announced that the device will be discontinued, and a lifetime-buy period is in effect.

NRND: Not recommended for new designs. Device is in production to support existing customers, but TI does not recommend using this part in a new design.

PREVIEW: Device has been announced but is not in production. Samples may or may not be available.

OBSOLETE: TI has discontinued the production of the device.

(2) **RoHS:** TI defines "RoHS" to mean semiconductor products that are compliant with the current EU RoHS requirements for all 10 RoHS substances, including the requirement that RoHS substance do not exceed 0.1% by weight in homogeneous materials. Where designed to be soldered at high temperatures, "RoHS" products are suitable for use in specified lead-free processes. TI may reference these types of products as "Pb-Free".

RoHS Exempt: TI defines "RoHS Exempt" to mean products that contain lead but are compliant with EU RoHS pursuant to a specific EU RoHS exemption.

Green: TI defines "Green" to mean the content of Chlorine (Cl) and Bromine (Br) based flame retardants meet JS709B low halogen requirements of <=1000ppm threshold. Antimony trioxide based flame retardants must also meet the <=1000ppm threshold requirement.

(3) MSL, Peak Temp. - The Moisture Sensitivity Level rating according to the JEDEC industry standard classifications, and peak solder temperature.

(4) There may be additional marking, which relates to the logo, the lot trace code information, or the environmental category on the device.

(5) Multiple Device Markings will be inside parentheses. Only one Device Marking contained in parentheses and separated by a "~" will appear on a device. If a line is indented then it is a continuation of the previous line and the two combined represent the entire Device Marking for that device.

⁽⁶⁾ Lead/Ball Finish - Orderable Devices may have multiple material finish options. Finish options are separated by a vertical ruled line. Lead/Ball Finish values may wrap to two lines if the finish value exceeds the maximum column width.

Important Information and Disclaimer:The information provided on this page represents TI's knowledge and belief as of the date that it is provided. TI bases its knowledge and belief on information provided by third parties, and makes no representation or warranty as to the accuracy of such information. Efforts are underway to better integrate information from third parties. TI has taken and continues to take reasonable steps to provide representative and accurate information but may not have conducted destructive testing or chemical analysis on incoming materials and chemicals. TI and TI suppliers consider certain information to be proprietary, and thus CAS numbers and other limited information may not be available for release.

In no event shall TI's liability arising out of such information exceed the total purchase price of the TI part(s) at issue in this document sold by TI to Customer on an annual basis.

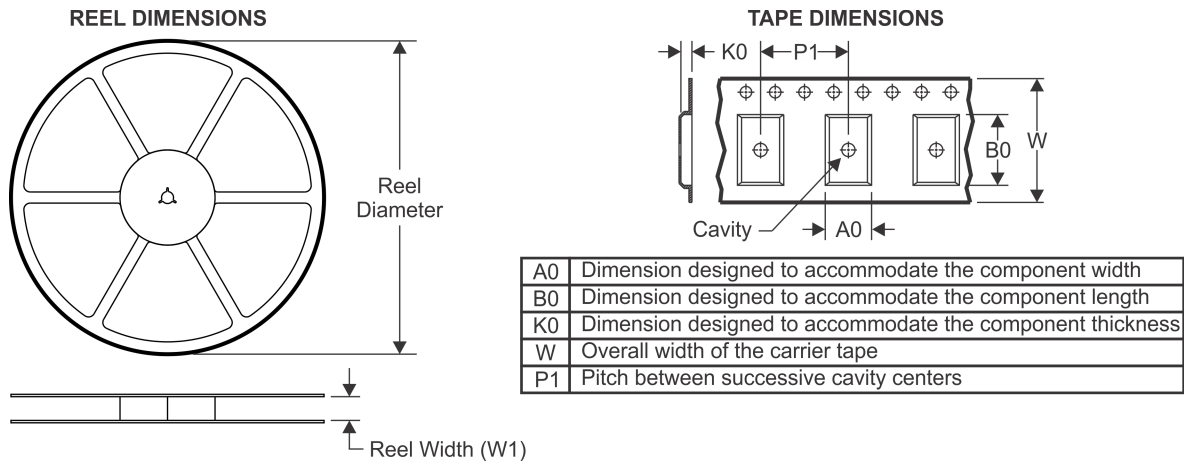
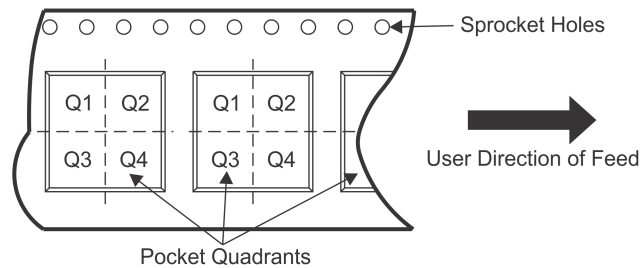
TAPE AND REEL INFORMATION

QUADRANT ASSIGNMENTS FOR PIN 1 ORIENTATION IN TAPE

*All dimensions are nominal

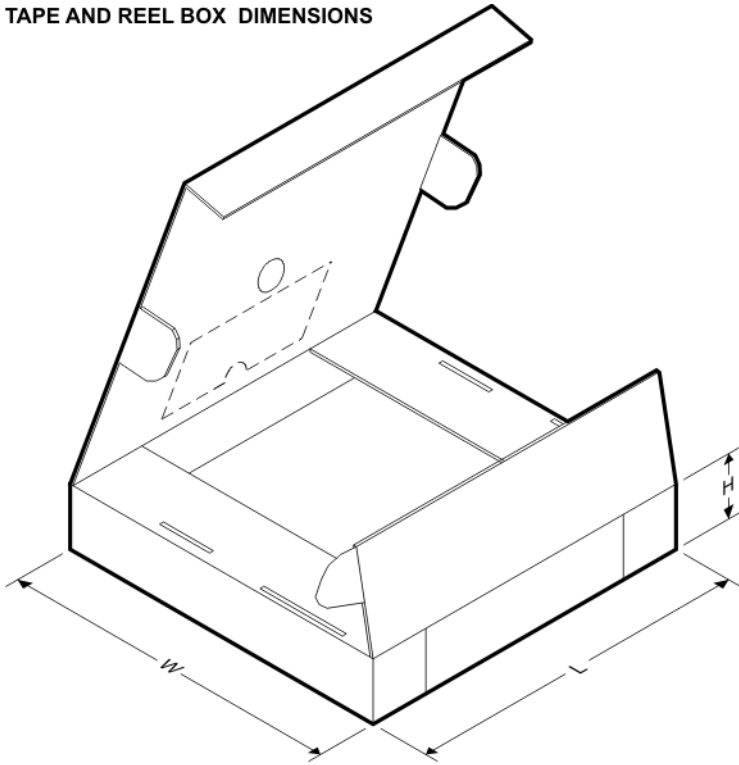
Device	Package Type	Package Drawing	Pins	SPQ	Reel Diameter (mm)	Reel Width W1 (mm)	A0 (mm)	B0 (mm)	K0 (mm)	P1 (mm)	W (mm)	Pin1 Quadrant
UCD3138ARGCR	VQFN	RGC	64	2000	330.0	16.4	9.3	9.3	1.1	12.0	16.0	Q2
UCD3138ARGCT	VQFN	RGC	64	250	180.0	16.4	9.3	9.3	1.1	12.0	16.0	Q2
UCD3138ARJAR	VQFN	RJA	40	3000	330.0	16.4	6.3	6.3	1.1	12.0	16.0	Q2
UCD3138ARJAT	VQFN	RJA	40	250	180.0	16.4	6.3	6.3	1.1	12.0	16.0	Q2
UCD3138ARMHR	WQFN	RMH	40	2000	330.0	16.4	6.3	6.3	1.1	12.0	16.0	Q2
UCD3138ARMHT	WQFN	RMH	40	250	180.0	16.4	6.3	6.3	1.1	12.0	16.0	Q2

TAPE AND REEL BOX DIMENSIONS

*All dimensions are nominal

Device	Package Type	Package Drawing	Pins	SPQ	Length (mm)	Width (mm)	Height (mm)
UCD3138ARGCR	VQFN	RGC	64	2000	367.0	367.0	38.0
UCD3138ARGCT	VQFN	RGC	64	250	210.0	185.0	35.0
UCD3138ARJAR	VQFN	RJA	40	3000	367.0	367.0	38.0
UCD3138ARJAT	VQFN	RJA	40	250	210.0	185.0	35.0
UCD3138ARMHR	WQFN	RMH	40	2000	367.0	367.0	38.0
UCD3138ARMHT	WQFN	RMH	40	250	210.0	185.0	35.0

EXAMPLE BOARD LAYOUT

RJA0040A

VQFN - 1 mm max height

PLASTIC QUAD FLATPACK - NO LEAD

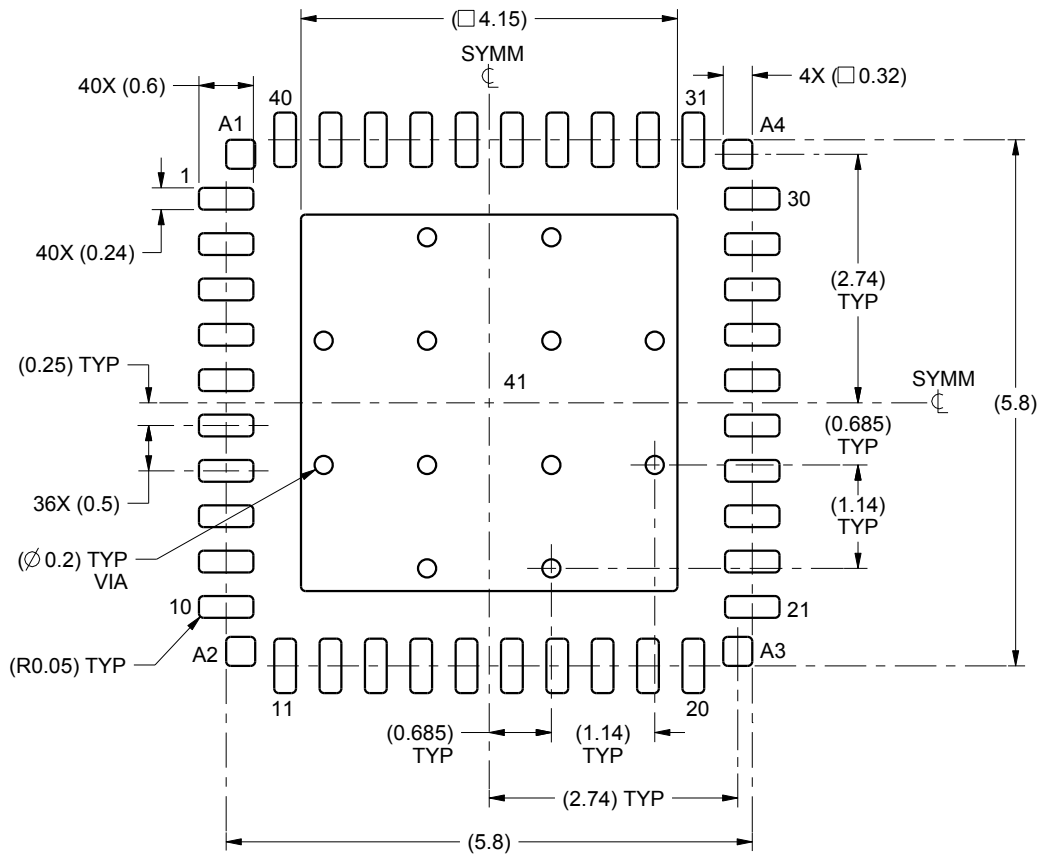

LAND PATTERN EXAMPLE
SCALE:12X

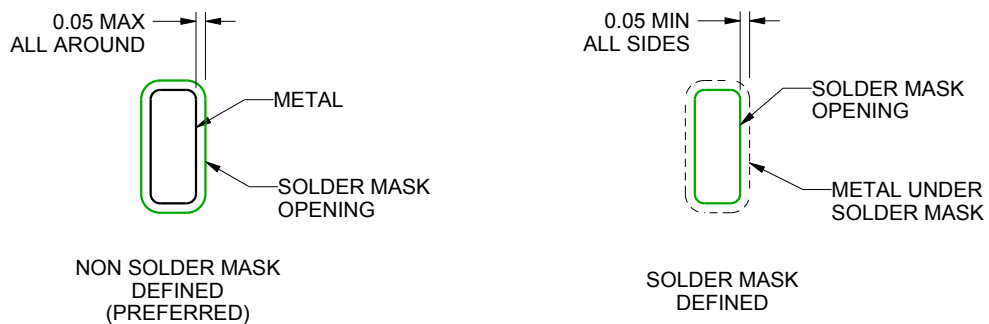

SOLDER MASK DETAILS

4222901/A 05/2016

NOTES: (continued)

4. This package is designed to be soldered to a thermal pad on the board. For more information, see Texas Instruments literature number SLUA271 (www.ti.com/lit/slua271).

EXAMPLE STENCIL DESIGN

RJA0040A

VQFN - 1 mm max height

PLASTIC QUAD FLATPACK - NO LEAD

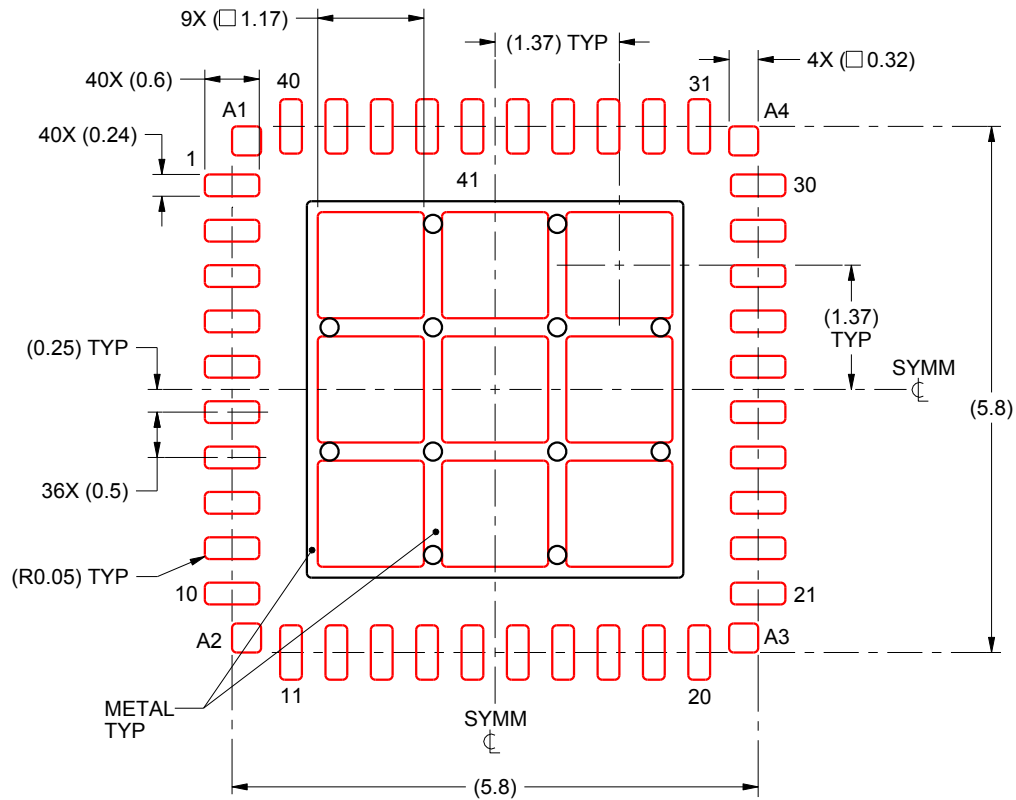

SOLDER PASTE EXAMPLE
BASED ON 0.125 mm THICK STENCIL

EXPOSED PAD 41:
72% PRINTED SOLDER COVERAGE BY AREA UNDER PACKAGE
SCALE:12X

4222901/A 05/2016

NOTES: (continued)

5. Laser cutting apertures with trapezoidal walls and rounded corners may offer better paste release. IPC-7525 may have alternate design recommendations.

RMH (S-PWQFN-N40)

PLASTIC QUAD FLATPACK NO-LEAD

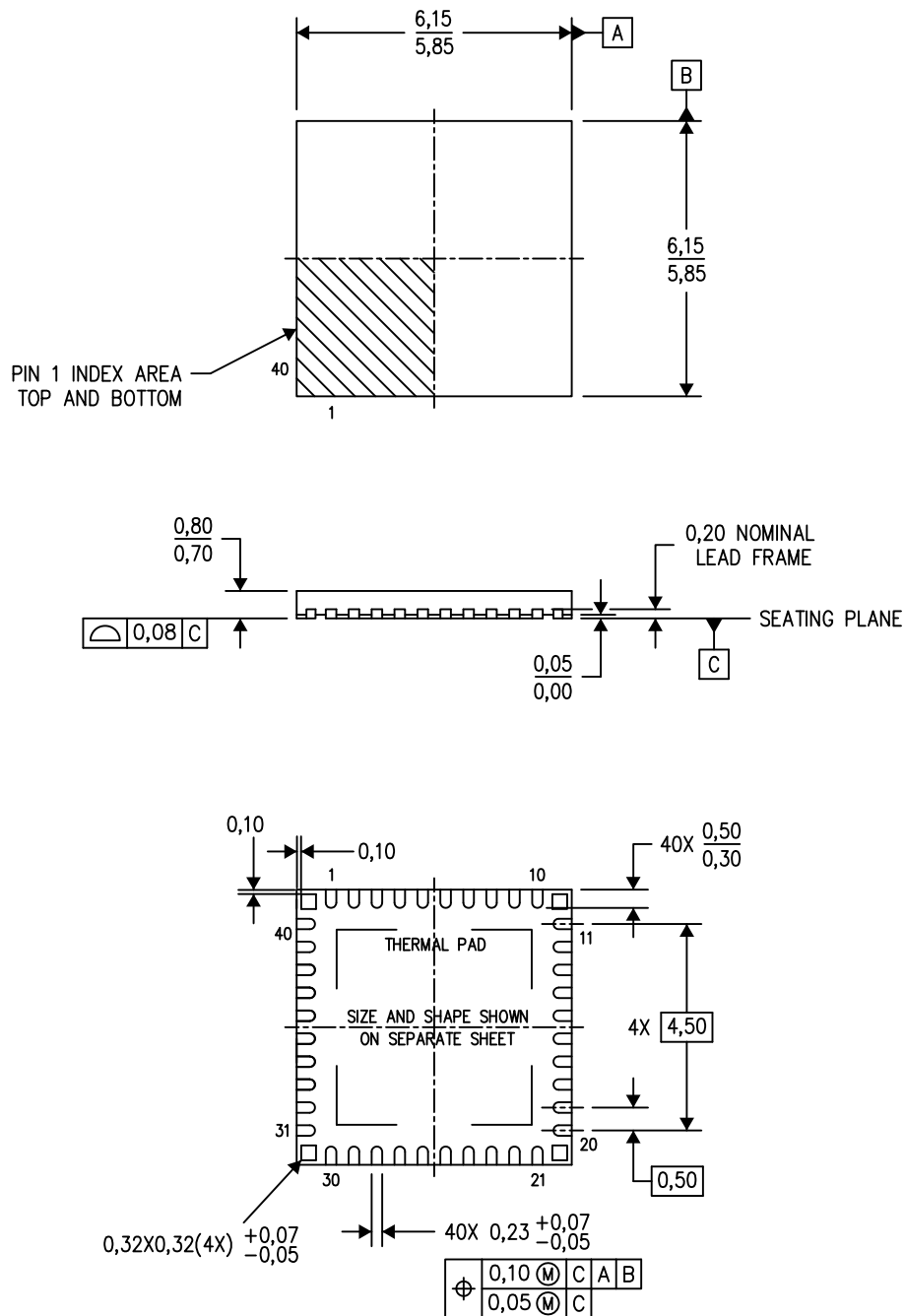

4218680/B 07/13

- NOTES:
- All linear dimensions are in millimeters. Dimensioning and tolerancing per ASME Y14.5M-1994.
 - This drawing is subject to change without notice.
 - QFN (Quad Flatpack No-Lead) Package configuration.
 - The package thermal pad must be soldered to the board for thermal and mechanical performance.
 - See the additional figure in the Product Data Sheet for details regarding the exposed thermal pad features and dimensions.

THERMAL PAD MECHANICAL DATA

RMH (S-PWQFN-N40)

PLASTIC QUAD FLATPACK NO-LEAD

THERMAL INFORMATION

This package incorporates an exposed thermal pad that is designed to be attached directly to an external heatsink. The thermal pad must be soldered directly to the printed circuit board (PCB). After soldering, the PCB can be used as a heatsink. In addition, through the use of thermal vias, the thermal pad can be attached directly to the appropriate copper plane shown in the electrical schematic for the device, or alternatively, can be attached to a special heatsink structure designed into the PCB. This design optimizes the heat transfer from the integrated circuit (IC).

For information on the Quad Flatpack No-Lead (QFN) package and its advantages, refer to Application Report, QFN/SON PCB Attachment, Texas Instruments Literature No. SLUA271. This document is available at www.ti.com.

The exposed thermal pad dimensions for this package are shown in the following illustration.

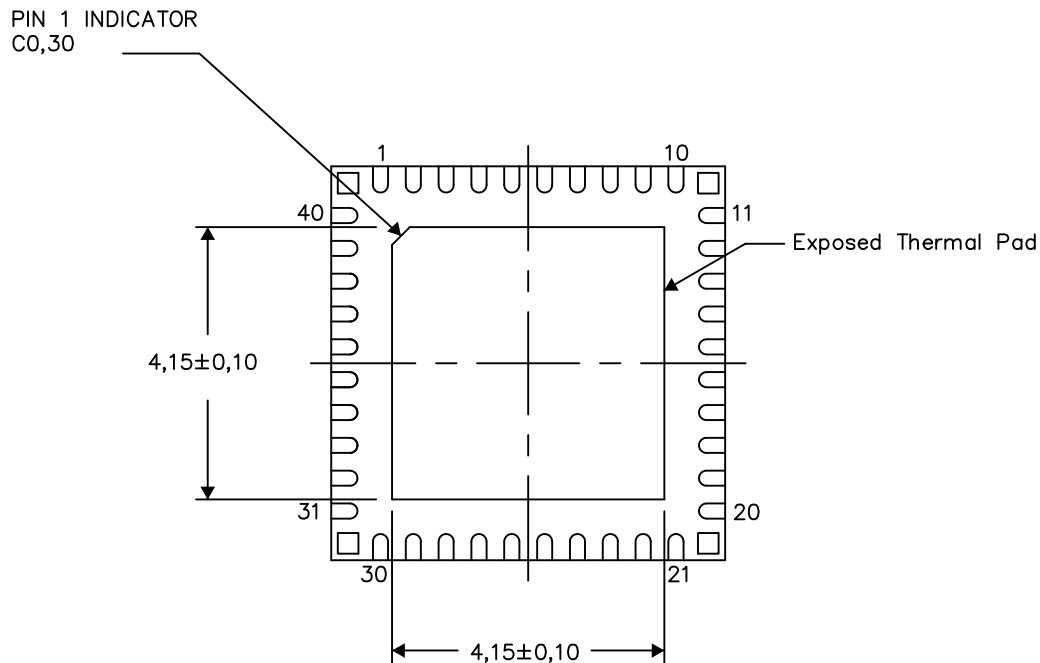

Bottom View

Exposed Thermal Pad Dimensions

4218753/B 08/13

NOTES: All linear dimensions are in millimeters

RMH (S-PWQFN-N40)

PLASTIC QUAD FLATPACK NO-LEAD

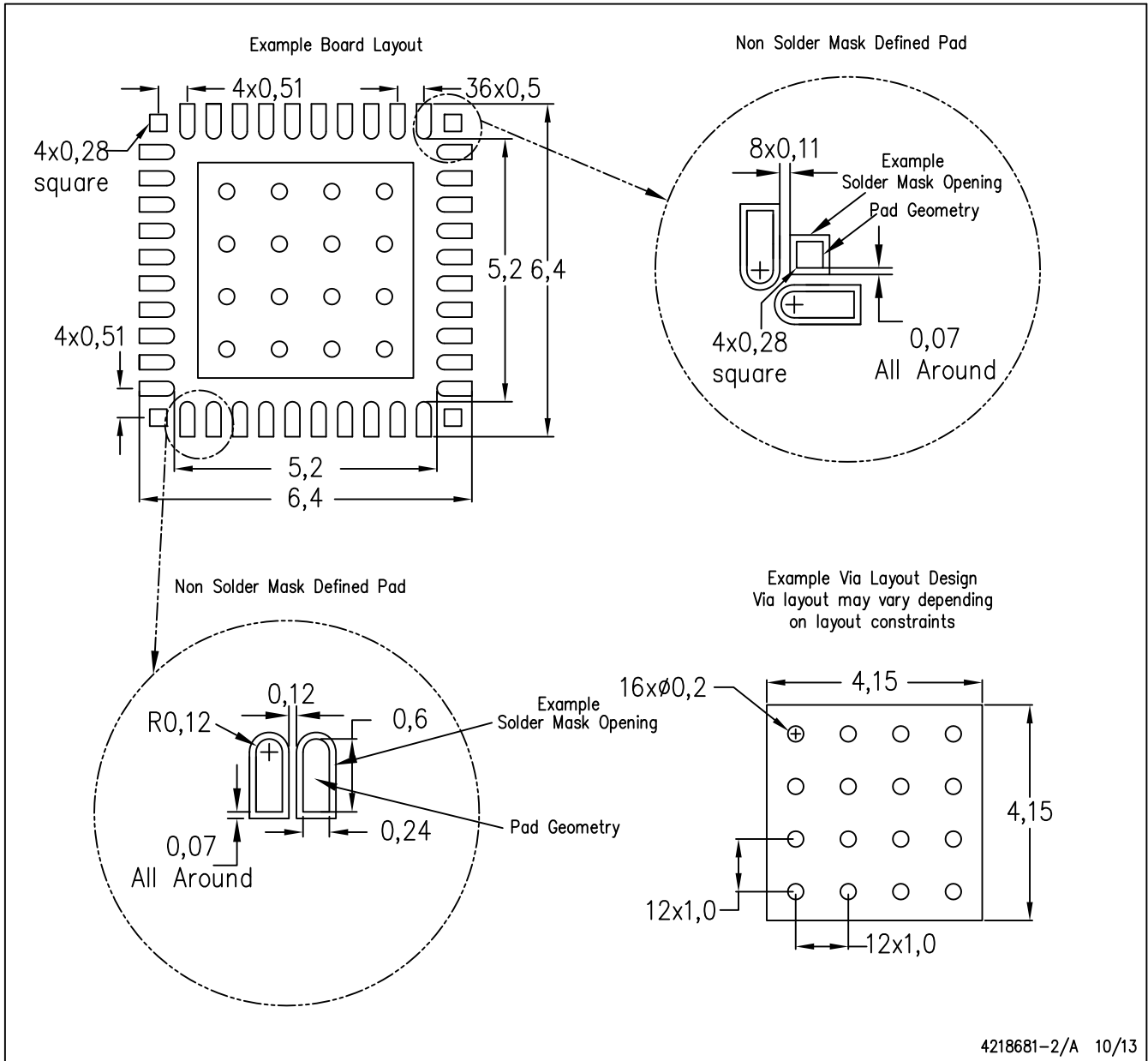

4218681-2/A 10/13

- NOTES:
- All linear dimensions are in millimeters.
 - This drawing is subject to change without notice.
 - Publication IPC-7351 is recommended for alternate designs.
 - This package is designed to be soldered to a thermal pad on the board. Refer to Application Note, Quad Flat-Pack Packages, Texas Instruments Literature No. SLUA271, and also the Product Data Sheets for specific thermal information, via requirements, and recommended board layout. These documents are available at www.ti.com <<http://www.ti.com>>.
 - Laser cutting apertures with trapezoidal walls and also rounding corners will offer better paste release. Customers should contact their board assembly site for stencil design recommendations. Refer to IPC 7525 for stencil design considerations.
 - Customers should contact their board fabrication site for recommended solder mask tolerances and via tenting recommendations for vias placed in the thermal pad.

RMH (S-PWQFN-N40)

PLASTIC QUAD FLATPACK NO-LEAD

Example Stencil Design
0,125 Thick Stencil

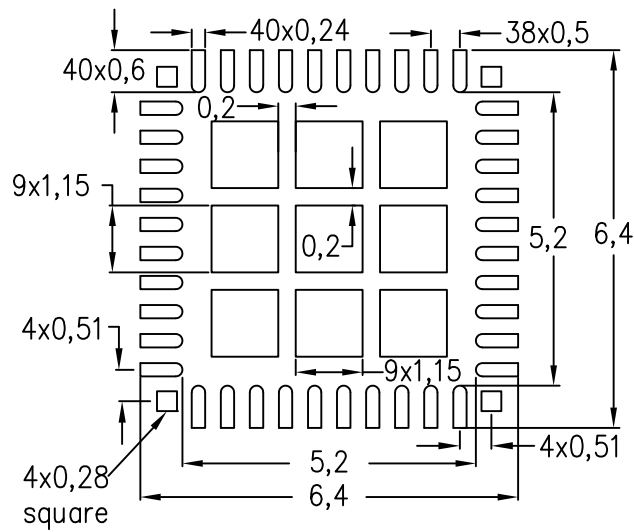

(69% Printed Solder Coverage by Area)

GENERIC PACKAGE VIEW

RGC 64

VQFN - 1 mm max height

9 x 9, 0.5 mm pitch

PLASTIC QUAD FLATPACK - NO LEAD

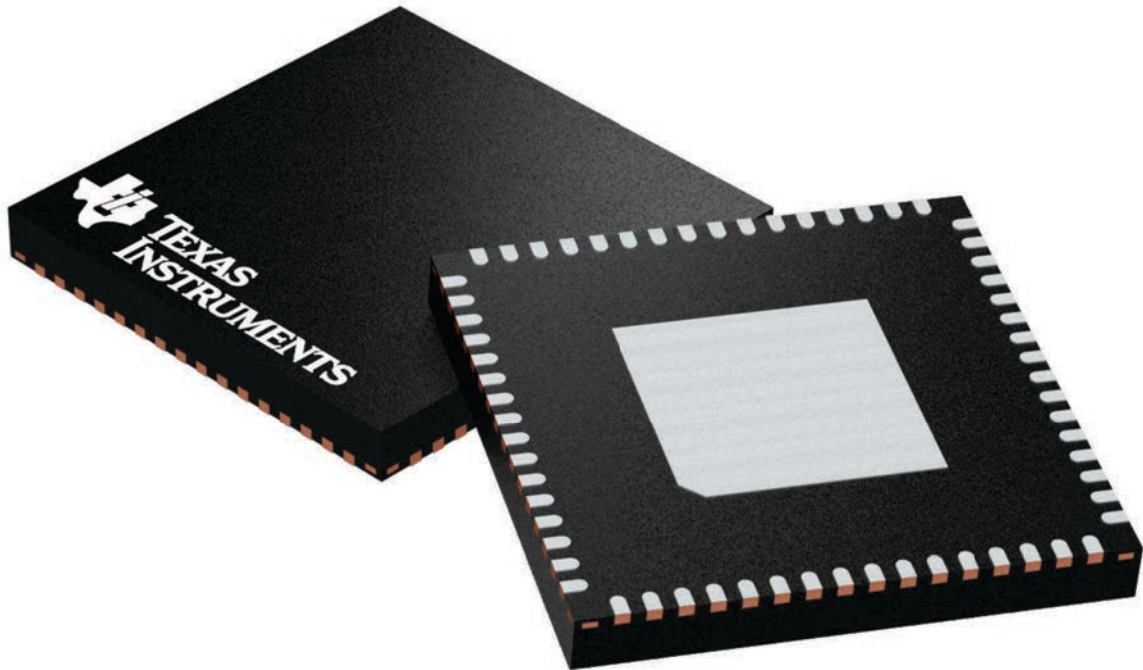

Images above are just a representation of the package family, actual package may vary.
Refer to the product data sheet for package details.

4224597/A

EXAMPLE BOARD LAYOUT

RGC0064B

VQFN - 1 mm max height

PLASTIC QUAD FLATPACK - NO LEAD

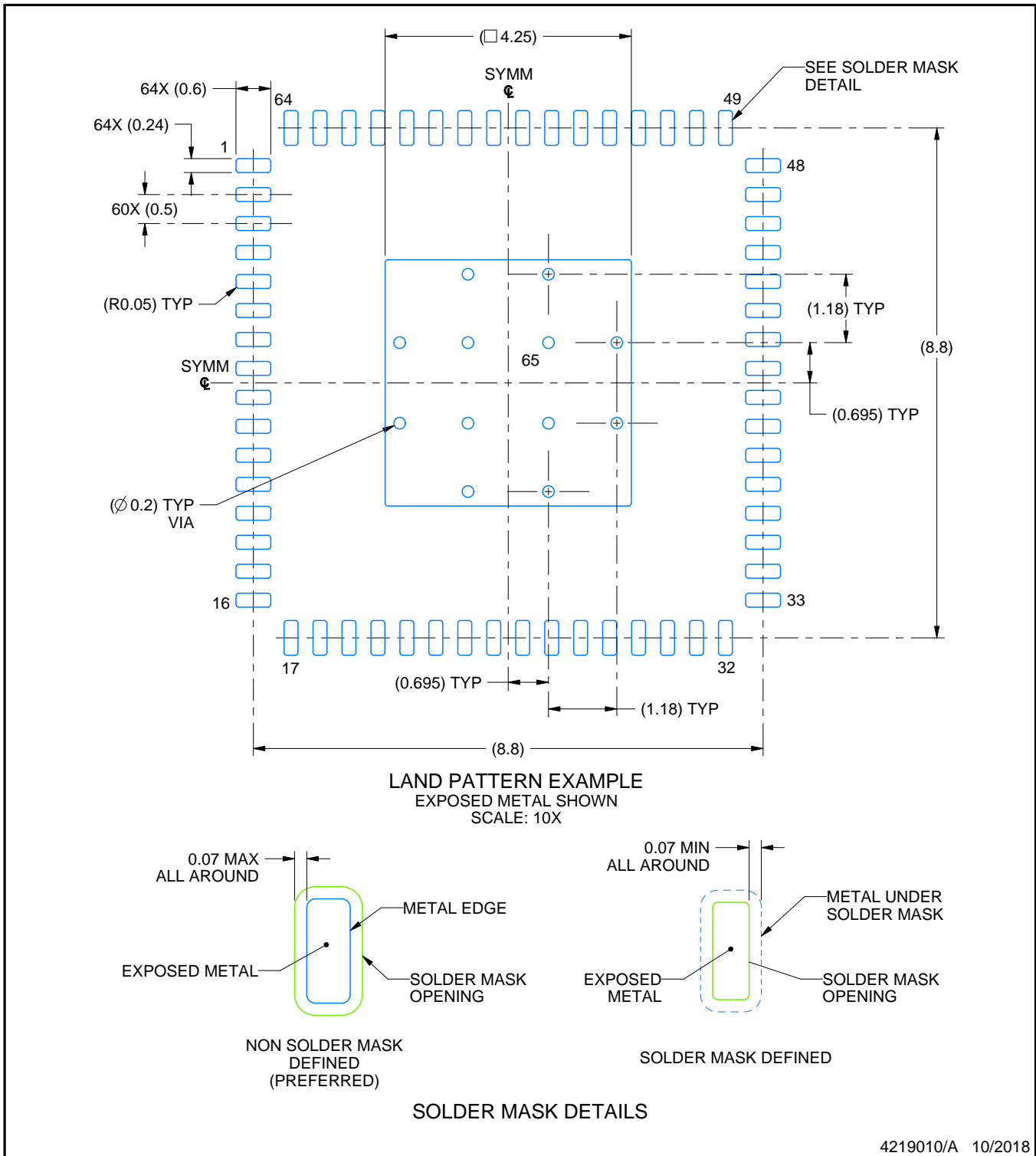

4219010/A 10/2018

NOTES: (continued)

4. This package is designed to be soldered to a thermal pad on the board. For more information, see Texas Instruments literature number SLUA271 (www.ti.com/lit/slua271).
5. Vias are optional depending on application, refer to device data sheet. If any vias are implemented, refer to their locations shown on this view. It is recommended that vias under paste be filled, plugged or tented.

EXAMPLE STENCIL DESIGN

RGC0064B

VQFN - 1 mm max height

PLASTIC QUAD FLATPACK - NO LEAD

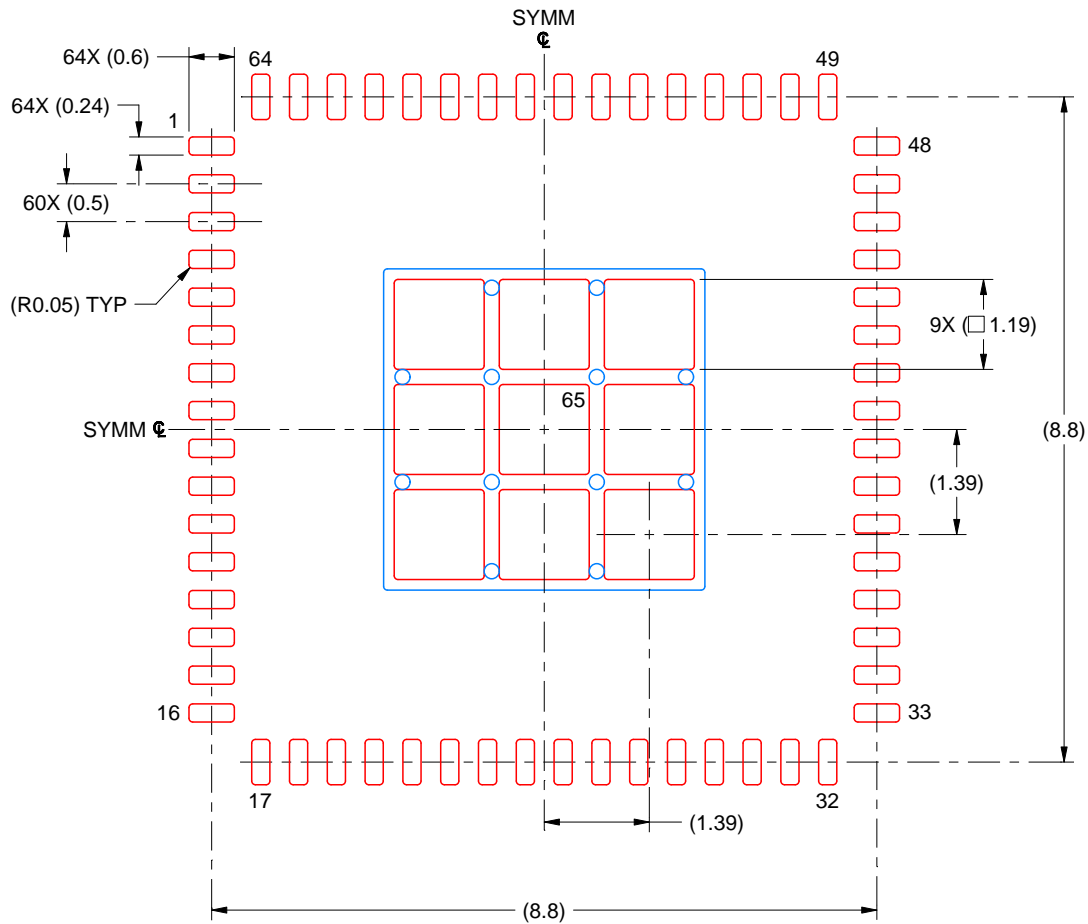

SOLDER PASTE EXAMPLE
BASED ON 0.125 MM THICK STENCIL
SCALE: 10X

EXPOSED PAD 65
71% PRINTED SOLDER COVERAGE BY AREA UNDER PACKAGE

4219010/A 10/2018

NOTES: (continued)

6. Laser cutting apertures with trapezoidal walls and rounded corners may offer better paste release. IPC-7525 may have alternate design recommendations.

IMPORTANT NOTICE AND DISCLAIMER

TI PROVIDES TECHNICAL AND RELIABILITY DATA (INCLUDING DATASHEETS), DESIGN RESOURCES (INCLUDING REFERENCE DESIGNS), APPLICATION OR OTHER DESIGN ADVICE, WEB TOOLS, SAFETY INFORMATION, AND OTHER RESOURCES "AS IS" AND WITH ALL FAULTS, AND DISCLAIMS ALL WARRANTIES, EXPRESS AND IMPLIED, INCLUDING WITHOUT LIMITATION ANY IMPLIED WARRANTIES OF MERCHANTABILITY, FITNESS FOR A PARTICULAR PURPOSE OR NON-INFRINGEMENT OF THIRD PARTY INTELLECTUAL PROPERTY RIGHTS.

These resources are intended for skilled developers designing with TI products. You are solely responsible for (1) selecting the appropriate TI products for your application, (2) designing, validating and testing your application, and (3) ensuring your application meets applicable standards, and any other safety, security, or other requirements. These resources are subject to change without notice. TI grants you permission to use these resources only for development of an application that uses the TI products described in the resource. Other reproduction and display of these resources is prohibited. No license is granted to any other TI intellectual property right or to any third party intellectual property right. TI disclaims responsibility for, and you will fully indemnify TI and its representatives against, any claims, damages, costs, losses, and liabilities arising out of your use of these resources.

TI's products are provided subject to TI's Terms of Sale (www.ti.com/legal/termsofsale.html) or other applicable terms available either on ti.com or provided in conjunction with such TI products. TI's provision of these resources does not expand or otherwise alter TI's applicable warranties or warranty disclaimers for TI products.

Mailing Address: Texas Instruments, Post Office Box 655303, Dallas, Texas 75265
Copyright © 2018, Texas Instruments Incorporated

Looking for pricing, stock, or lifecycle information?

Click below to explore more details on WIN SOURCE:

 [View UCD3138ARGCT](#) on WIN SOURCE

 [Texas Instruments](#) Information

Optimize Your Supply Chain with WIN SOURCE Solutions

-  Global Sourcing Solution
-  Obsolete Management
-  Cost Control Management
-  Shortage Management
-  Alternative Solution
-  Excess Inventory Management