

- **Designed for Analog and Digital Wireless Handsets, Voice-Enabled Terminals, and Telecommunications Applications**
- **2.7-V to 3.3-V Operation**
- **Selectable 13-Bit Linear or 8-Bit μ -Law Companded Conversion**
- **Differential Microphone Input with External Gain Setting**
- **Differential Earphone Output Capable of Driving a 32- Ω to 8- Ω Load**
- **Programmable Volume Control in Linear Mode**
- **Microphone (MIC) and Earphone (EAR) Mute Functions**
- **Typical Power Dissipation of 0.03 mW in Power-Down Mode**
- **2.048-MHz Master Clock Rate**
- **300-Hz to 3.4-kHz Passband**
- **Low Profile 20-Terminal TSSOP Packaging**

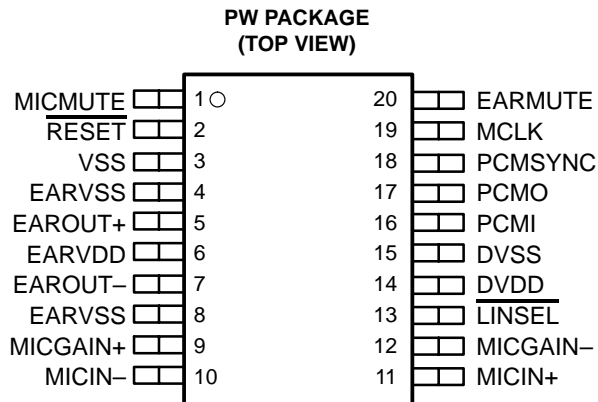

description

The TWL1106 voice-band audio processor (VBAP) is designed to perform transmit encoding analog-to-digital (A/D) conversion, receive decoding digital-to-analog (D/A) conversion, and the transmit and receive filtering for voice-band communications systems. The TWL1106 device operates in either the 13-bit linear or 8-bit companded (μ -law) mode. The VBAP generates its own internal clocks from a 2.048-MHz master clock input.



This device contains circuits to protect its inputs and outputs against damage due to high static voltages or electrostatic fields. These circuits have been qualified to protect this device against electrostatic discharges (ESD) of up to 2 kV according to MIL-STD-883C, Method 3015; however, it is advised that precautions be taken to avoid application of any voltage higher than maximum-rated voltages to these high-impedance circuits. During storage or handling, the device leads should be shorted together or the device should be placed in conductive foam. In a circuit, unused inputs should always be connected to an appropriated logic voltage level, preferably either V_{CC} or ground. Specific guidelines for handling devices of this type are contained in the publication *Guidelines for Handling Electrostatic-Discharge-Sensitive (ESDS) Devices and Assemblies* available from Texas Instruments.



Please be aware that an important notice concerning availability, standard warranty, and use in critical applications of Texas Instruments semiconductor products and disclaimers thereto appears at the end of this data sheet.

VBAP is a trademark of Texas Instruments.
All other trademarks are products of their respective owners.

PRODUCTION DATA information is current as of publication date. Products conform to specifications per the terms of Texas Instruments standard warranty. Production processing does not necessarily include testing of all parameters.



TWL1106 VOICE-BAND AUDIO PROCESSOR (VBAP™)

SLWS094 – JUNE 2001

functional block diagram

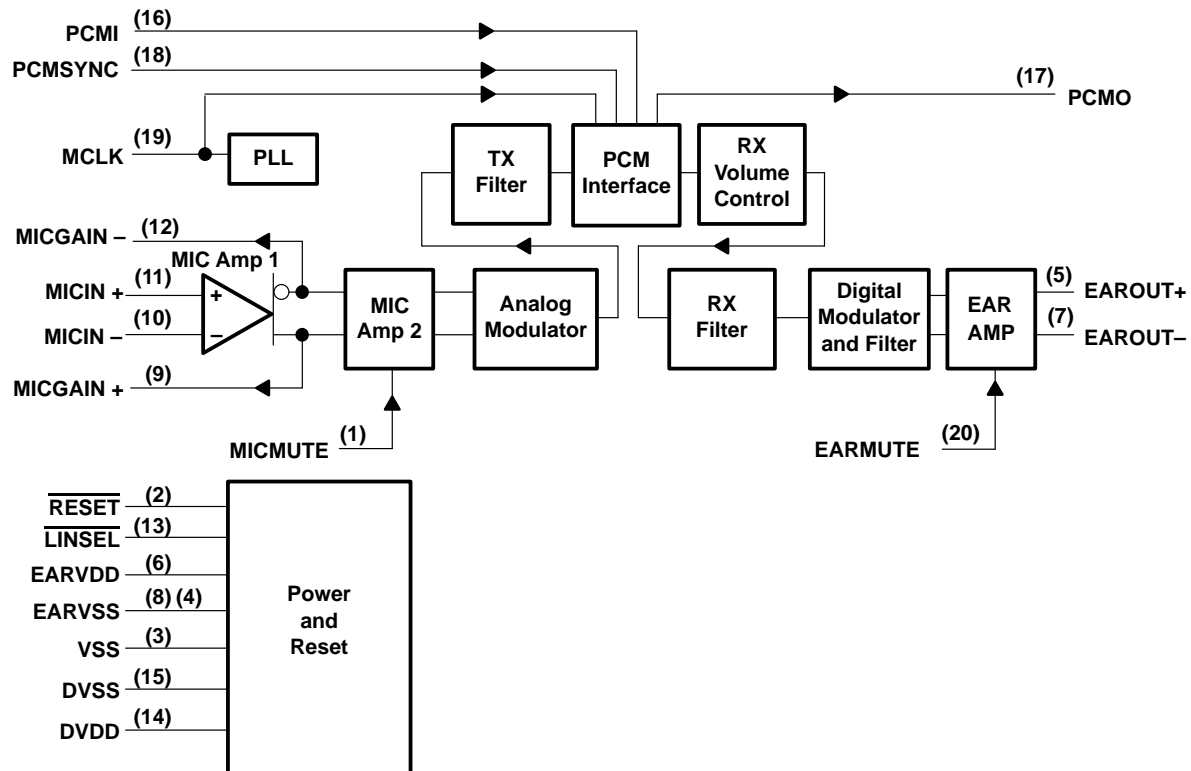

RX = Receive
TX = Transmit

detailed description

power up/reset

An external reset must be applied to the active-low $\overline{\text{RESET}}$ terminal while MCLK is active to ensure reset at power up.

reference

A precision band-gap reference voltage is generated internally and supplies all required references to operate the transmit and receive channels.

phase-locked loop

The phase-locked loop generates the internal clock frequency required for internal digital filters and modulators by phase locking to 2.048-MHz master clock input.

PCM interface

The PCM interface transmits and receives data at the PCMO and PCMI terminals, respectively. The data is transmitted or received at the MCLK speed once on each PCMSYN cycle. The PCMSYN can be driven by an external source that is derived from the master clock and used as an interrupt to the host controller.

microphone input

The microphone input circuit consists of two differential input/differential output amplifiers (MIC Amp 1 and MIC Amp 2). MIC Amp 1 is a low-noise differential amplifier capable of an externally set gain. MIC Amp 2 is a differential amplifier with a fixed gain of 6 dB.

analog modulator

The transmit channel modulator is a third-order sigma-delta design.

transmit filter

The transmit filter is a digital filter designed to meet Consultive Committee on International Telegraphy and Telephony (CCITT) G.714 requirements. The TWL1106 device operates in either the 13-bit linear or 8-bit companded μ -law mode.

receive filter

The receive (RX) filter is a digital filter that meets CCITT G.714 requirements. The TWL1106 device operates in either the 13-bit linear or 8-bit μ -law companded mode, which is selected at the $\overline{\text{LINSEL}}$ input.

receive volume control

In linear mode, the three least significant bits of the 16-bit PCMI data sample is used to control volume. The volume range is -18 dB to 3 dB in 3-dB steps.

digital modulator and filter

The second-order digital modulator and filter convert the received digital PCM data to the analog output required by the earphone interface.

earphone amplifiers

EAROUT is recommended for use as a differential output; however, it can be connected in single-ended topology as well. Clicks and pops are suppressed from the differential output.

TWL1106 VOICE-BAND AUDIO PROCESSOR (VBAP™)

SLWS094 – JUNE 2001

Terminal Functions

TERMINAL TERMINAL NO.	I/O	DESCRIPTION
EARVSS 4	I	Analog ground for EAROUT+
DVDD 14	I	Digital positive power supply
DVSS 15	I	Digital negative power supply
EARMUTE 20	I	Earphone mute
EAROUT– 7	O	Earphone amplifier negative output
EAROUT+ 5	O	Earphone amplifier positive output
EARVDD 6	I	Analog positive power supply for the earphone amplifiers
EARVSS 8	I	Analog ground for EAROUT–
LINSEL 13	I	Companding enable
MCLK 19	I	Master system clock input (2.048 MHz) (digital)
MICGAIN+ 9	I	Microphone gain positive feedback
MICGAIN– 12	I	Microphone gain negative feedback
MICMUTE 1	I	Microphone mute
MICIN– 10	I	Microphone negative input (–)
MICIN+ 11	I	Microphone positive input (+)
PCMI 16	I	Receive PCM input
PCMO 17	O	Transmit PCM output
PCMSYNC 18	I	PCM frame synchronization
RESET 2	I	Active-low reset
VSS 3	I	Ground return for band-gap internal reference

absolute maximum ratings over operating free-air temperature range (unless otherwise noted)†

Supply voltage range, DV_{DD} , $EARV_{DD}$	–0.5 V to 3.6 V
Output voltage range, V_O	–0.5 V to 3.6 V
Input voltage range, V_I	–0.5 V to 3.6 V
Continuous total power dissipation	See Dissipation Rating Table
Operating free air temperature range, T_A	–40°C to 85°C
Storage temperature range, T_{stg}	–65°C to 150°C
Lead temperature 1,6 mm from case for 10 seconds	260°C

† Stresses beyond those listed under “absolute maximum ratings” may cause permanent damage to the device. These are stress ratings only, and functional operation of the device at these or any other conditions beyond those indicated under “recommended operating conditions” is not implied. Exposure to absolute-maximum-rated conditions for extended periods may affect device reliability.

DISSIPATION RATING TABLE

PACKAGE	$T_A \leq 25^\circ\text{C}$ POWER RATING	DERATING FACTOR ABOVE $T_A = 25^\circ\text{C}$	$T_A = 85^\circ\text{C}$ POWER RATING
PW	680 W	6.8 W/°C	270 W



recommended operating conditions (see Note 2)

	MIN	NOM	MAX	UNIT
Supply voltage, DV_{DD} , $EARV_{DD}$	2.7		3.3	V
High-level input voltage, V_{IH}	0.7x V_{DD}			V
Low-level input voltage, V_{IL}			0.3x V_{DD}	V
Load impedance between $EAROUT+$ and $EAROUT-$, R_L	8 to 32			Ω
Input voltage, $MICIN$			0.9x V_{DD}	V
Operating free-air temperature, T_A	-40		85	$^{\circ}C$

- NOTES: 1. To avoid possible damage and resulting reliability problems to these CMOS devices, follow the power-up sequence detailed in the system reliability features paragraph.
2. Voltages are with respect to DV_{SS} , and $EARV_{SS}$.

electrical characteristics over recommended ranges of supply voltage and operating free-air temperature (unless otherwise noted)

supply current

PARAMETER		TEST CONDITIONS	MIN	TYP	MAX	UNIT
I_{DD}	Supply current from V_{DD}	Operating		5	7	mA
		Power down, $MCLK$ not present		10	30	μA
t_{pu}	Power-up time from power down				10	ms

digital interface

PARAMETER		TEST CONDITIONS	MIN	TYP	MAX	UNIT
V_{OH}	High-level output voltage, PCMO	$I_{OH} = -3.2$ mA, $V_{DD} = 3$ V	$DV_{DD} - 0.25$			V
V_{OL}	Low-level output voltage, PCMO	$I_{OL} = 3.2$ mA, $V_{DD} = 3$ V			0.2	V
I_{IH}	High-level input current, any digital input	$V_I = 2.2$ V to V_{DD}			10	μA
I_{IL}	Low-level input current, any digital input	$V_I = 0$ to 0.8 V			10	μA
C_I	Input capacitance				10	pF
C_O	Output capacitance				20	pF

microphone interface

PARAMETER		TEST CONDITIONS	MIN	TYP	MAX	UNIT
V_{IO}	Input offset voltage	See Note 3	-5		5	mV
I_{IB}	Input bias current		-250		250	nA
C_i	Input capacitance			5		pF
V_n	Microphone input referred noise, psophometric weighted	MIC Amp 1 gain = 23.5 dB, See Note 4		2.9	4	μV_{rms}
	MICMUTE		-80			dB

- NOTES: 3. Measured while $MICIN+$ and $MICIN-$ are connected together. Less than a 0.5-mV offset results in 0 value code on $PCMOUT$.
4. Configured as shown in Figure 3.

TWL1106

VOICE-BAND AUDIO PROCESSOR (VBAP™)

SLWS094 – JUNE 2001

electrical characteristics over recommended ranges of supply voltage and operating free-air temperature (unless otherwise noted) (continued)

speaker interface

PARAMETER		TEST CONDITIONS	MIN	TYP	MAX	UNIT
Earphone AMP output power (see Note 5)		$V_{DD} = 2.7$ V, fully differential, 8- Ω load, 3-dBm0 output, volume control = -3 dB, PCMI data input to -4 dB level		161	200	mW
		$V_{DD} = 2.7$ V, fully differential, 16- Ω load, 3-dBm0 output, volume control = -3 dB, PCMI data input to -2 dB level		128	160	
		$V_{DD} = 2.7$ V, fully differential, 32- Ω load, 3-dBm0 output, volume control = -3 dB, PCMI data input to -1 dB level		81	100	
I_{Omax} Maximum output current for EAROUT (rms)		3-dBm0 input, 8- Ω load		141	178	mA
		3-dBm0 input, 16- Ω load		90	112	
		3-dBm0 input, 32- Ω load		50	63	
EARMUTE			-80			dB

NOTE 5: Maximum power is with a load impedance of -20%, at 25°C.

transmit gain and dynamic range, companded mode (μ -law) or linear mode selected (see Notes 6 and 7)

PARAMETER		TEST CONDITIONS	MIN	TYP	MAX	UNIT
Transmit reference-signal level (0dB)		Differential, MIC Amp 1 configured for 23.5 dB gain			88	mV _{pp}
Overload-signal level (3 dBm0)		Differential, MIC Amp 1 configured for 23.5 dB gain			124	mV _{pp}
Absolute gain error		0 dBm0 input signal, 2.7 V $\leq V_{DD} \leq 3.3$ V	-1		1	dB
Gain error with input level relative to gain at -10 dBm0 MICIN, MICIN+ to PCMO		MICIN-, MICIN+ to PCMO at 3 dBm0 to -30 dBm0	-0.5		0.5	dB
		MICIN-, MICIN+ to PCMO at -31 dBm0 to -45 dBm0	-1		1	
		MICIN-, MICIN+ to PCMO at -46 dBm0 to -55 dBm0	-1.2		1.2	

NOTES: 6. Unless otherwise noted, the analog input is 0 dB, 1020-Hz sine wave, where 0 dB is defined as the zero-reference point of the channel under test.

7. The reference signal level, which is input to the transmit channel, is defined as a value 3 dB below the full-scale value of 124-mV_{pp}.

transmit filter transfer, companded mode (μ -law) or linear mode selected

PARAMETER		TEST CONDITIONS	MIN	TYP	MAX	UNIT
Gain relative to input signal gain at 1.02 kHz		$f_{MIC} < 100$ Hz	-0.5		0.5	dB
		$f_{MIC} = 200$ Hz	-0.5		0.5	
		$f_{MIC} = 300$ Hz to 3 kHz	-0.5		0.5	
		$f_{MIC} = 3.4$ kHz	-1.5		0	
		$f_{MIC} = 4$ kHz			-14	
		$f_{MIC} = 4.6$ kHz			-35	
		$f_{MIC} = 8$ kHz			-47	



electrical characteristics over recommended ranges of supply voltage and operating free-air temperature (unless otherwise noted) (continued)

transmit idle channel noise and distortion, companded mode (μ -law) selected

PARAMETER	TEST CONDITIONS	MIN	TYP	MAX	UNIT
Transmit idle channel noise, psophometrically weighted	MIC Amp 1 configured for 23.5 dB gain (see Note 8)		-80	-70	dBm _{0p}
Transmit signal-to-distortion ratio with 1.02-kHz sine-wave input	MICIN-, MICIN+ to PCMO at 3 dBm0	27			dBm0
	MICIN-, MICIN+ to PCMO at 0 dBm0	30			
	MICIN-, MICIN+ to PCMO at -5 dBm0	33			
	MICIN-, MICIN+ to PCMO at -10 dBm0	36			
	MICIN-, MICIN+ to PCMO at -20 dBm0	35			
	MICIN-, MICIN+ to PCMO at -30 dBm0	26			
	MICIN-, MICIN+ to PCMO at -40 dBm0	24			
Intermodulation distortion, 2-tone CCITT method, composite power level, -13 dBm0	CCITT G.712 (7.1), R2	49			dB
	CCITT G.712 (7.2), R2	51			

NOTE 8: With recommended impedances and resistor tolerance of 1%

transmit idle channel noise and distortion, linear mode selected

PARAMETER	TEST CONDITIONS	MIN	TYP	MAX	UNIT
Transmit idle channel noise, psophometrically weighted	MIC Amp 1 configured for 23.5 dB gain (see Note 8)		-80	-74	dBm _{0p}
Transmit signal-to-total distortion ratio with 1.02-kHz sine-wave input	MICIN-, MICIN+ to PCMO at 3 dBm0	40	55		dB
	MICIN-, MICIN+ to PCMO at 0 dBm0	50	61		
	MICIN-, MICIN+ to PCMO at -5 dBm0	52	62		
	MICIN-, MICIN+ to PCMO at -10 dBm0	56	66		
	MICIN-, MICIN+ to PCMO at -20 dBm0	52	68		
	MICIN-, MICIN+ to PCMO at -30 dBm0	51	61		
	MICIN-, MICIN+ to PCMO at -40 dBm0	43	59		
MICIN-, MICIN+ to PCMO at -45 dBm0	38	55			

NOTE 8: With recommended impedances and resistor tolerance of 1%

receive gain and dynamic range, linear or companded (μ -law) mode selected (see Note 9)

PARAMETER	TEST CONDITIONS	MIN	TYP	MAX	UNIT
Overload-signal level (3 dB)	Load = 8 Ω , volume control = -3 dB, PCMI data input to -4 dB level		3.20		V _{pp}
	Load = 16 Ω , volume control = -3 dB, PCMI data input to -2 dB level		4.05		
	Load = 32 Ω , volume control = -3 dB, PCMI data input to -1 dB level		4.54		
Absolute gain error	0 dBm0 input signal, 2.7 V \leq V _{DD} \leq 3.3 V	-1		1	dB
Gain error with output level relative to gain at -10 dBm0	PCMI to EAROUT-, EAROUT+ at 3 dBm0 to -40 dBm0	-0.5		0.5	dB
	PCMI to EAROUT-, EAROUT+ at -41 dBm0 to -50 dBm0	-1		1	
	PCMI to EAROUT-, EAROUT+ at -51 dBm0 to -55 dBm0	-1.2		1.2	

NOTE 9: 1020-Hz input signal at PCMI, output measured differentially between EAROUT- and EAROUT+

TWL1106

VOICE-BAND AUDIO PROCESSOR (VBAP™)

SLWS094 – JUNE 2001

electrical characteristics over recommended ranges of supply voltage and operating free-air temperature (unless otherwise noted) (continued)

receive filter transfer, companded mode (μ -law) or linear mode selected (MCLK = 2.048 MHz) (see Note 10)

PARAMETER	TEST CONDITIONS	MIN	TYP	MAX	UNIT
Gain relative to input signal gain at 1.02-kHz	$f_{\text{EAROUT}} < 100 \text{ Hz}$			-15	dB
	$f_{\text{EAROUT}} = 200 \text{ Hz}$			-5	
	$f_{\text{EAROUT}} = 300 \text{ Hz to } 3 \text{ kHz}$	-0.5		0.5	
	$f_{\text{EAROUT}} = 3.4 \text{ kHz}$	-1.5		0	
	$f_{\text{EAROUT}} = 4 \text{ kHz}$			-14	
	$f_{\text{EAROUT}} = 4.6 \text{ kHz}$			-35	
	$f_{\text{EAROUT}} = 8 \text{ kHz}$			-47	

NOTE 10: Volume control = -3 dB, PCMI data input to -1 dB level (32- Ω load)

receive idle channel noise and distortion, companded mode (μ -law) selected (see Note 10)

PARAMETER	TEST CONDITIONS	MIN	TYP	MAX	UNIT
Receive noise, C-message weighted	PCMI = 11111111 (μ -law)		-90	-88	dBm0
Receive signal-to-distortion ratio with 1.02-kHz sine-wave input	PCMI to EAROUT-, EAROUT+ at 3 dBm0	21			dB
	PCMI to EAROUT-, EAROUT+ at 0 dBm0	25			
	PCMI to EAROUT-, EAROUT+ at -5 dBm0	36			
	PCMI to EAROUT-, EAROUT+ at -10 dBm0	43			
	PCMI to EAROUT-, EAROUT+ at -20 dBm0	40			
	PCMI to EAROUT-, EAROUT+ at -30 dBm0	38			
	PCMI to EAROUT-, EAROUT+ at -40 dBm0	28			
PCMI to EAROUT-, EAROUT+ at -45 dBm0	23				

NOTE 10: Volume control = -3 dB, PCMI data input to -1 dB level (32- Ω load)

receive idle channel noise and distortion, linear mode selected (see Note 10)

PARAMETER	TEST CONDITIONS	MIN	TYP	MAX	UNIT
Receive noise, (20-Hz to 20-kHz brickwall window)	PCMI = 00000000000000		-83	-78	dBm0
Receive signal-to-distortion ratio with 1.02-kHz sine-wave input (0-4 kHz)	PCMI to EAROUT-, EAROUT+ at 3 dBm0	48	52		dB
	PCMI to EAROUT-, EAROUT+ at 0 dBm0	51	56		
	PCMI to EAROUT-, EAROUT+ at -5 dBm0	57	59		
	PCMI to EAROUT-, EAROUT+ at -10 dBm0	55	62		
	PCMI to EAROUT-, EAROUT+ at -20 dBm0	51	53		
	PCMI to EAROUT-, EAROUT+ at -30 dBm0	45	47		
	PCMI to EAROUT-, EAROUT+ at -40 dBm0	42	47		
PCMI to EAROUT-, EAROUT+ at -45 dBm0	35	45			
Intermodulation distortion, 2-tone CCITT method, composite power level, -13 dBm0	CCITT G.712 (7.1), R2	50			dB
	CCITT G.712 (7.2), R2	54			

NOTE 10: Volume control = -3 dB, PCMI data input to -1 dB level (32- Ω load)



electrical characteristics over recommended ranges of supply voltage and operating free-air temperature (unless otherwise noted) (continued)

power supply rejection

PARAMETER	TEST CONDITIONS	MIN	TYP	MAX	UNIT
Supply voltage rejection, transmit channel	MICIN–, MICIN+ = 0 V, V _{DD} = 2.7 V + 100 mV _{pp} , f = 1 kHz, Resistor tolerance of 1%		–74	–50	dB
Supply voltage rejection, receive channel (differential)	PCM code = positive zero, V _{DD} = 2.7 V + 100 mV _{pp} , f = 1 kHz, Resistor tolerance of 1%		–80	–65	dB

crosstalk attenuation, linear mode selected

PARAMETER	TEST CONDITIONS	MIN	TYP	MAX	UNIT
Crosstalk attenuation, transmit-to-receive (differential)	MICIN–, MICIN+ = 0 dB, f = 300 Hz to 3400 Hz measured differentially between EAROUT– and EAROUT+	70			dB
Crosstalk attenuation, receive-to-transmit	PCMI = 0 dBm0, f = 300 Hz to 3400 Hz measured at PCMO	70			dB

timing requirements

clock

	MIN	NOM	MAX	UNIT
t _t Transition time, MCLK			10	ns
f _{mclk} MCLK frequency		2.048		MHz
MCLK jitter			37%	
MCLK clock cycles per PCMSYN frame	256		256	cycles

transmit (see Figure 1)

	MIN	MAX	UNIT
t _{su} (PCMSYN) Setup time, PCMSYN high before MCLK ↓	20	t _c (MCLK)–20	ns
t _h (PCMSYN) Hold time, PCMSYN high after MCLK ↓	20	t _c (MCLK)–20	

receive (see Figure 2)

	MIN	MAX	UNIT
t _{su} (PCSYN) Setup time, PCMSYN high before MCLK ↓	20	t _c (MCLK)–20	ns
t _h (PCSYN) Hold time, PCMSYN high after MCLK ↓	20	t _c (MCLK)–20	ns
t _{su} (PCMI) Setup time, PCMI high or low before MCLK ↓	20		ns
t _h (PCMI) Hold time, PCMI high or low after MCLK ↓	20		ns

switching characteristics over recommended operating conditions, C_L max = 10 pF (see Figure 1)

	TEST CONDITIONS	MIN	MAX	UNIT
t _{pd1} Propagation delay time, MCLK bit 1 high to PCMO bit 1 valid			35	ns
t _{pd2} Propagation delay time, MCLK high to PCMO valid, bits 2 to n			35	ns
t _{pd3} Propagation delay time, MCLK bit n low to PCMO bit n Hi-Z		30		ns

TWL1106 VOICE-BAND AUDIO PROCESSOR (VBAP™)

SLWS094 – JUNE 2001

PARAMETER MEASUREMENT INFORMATION

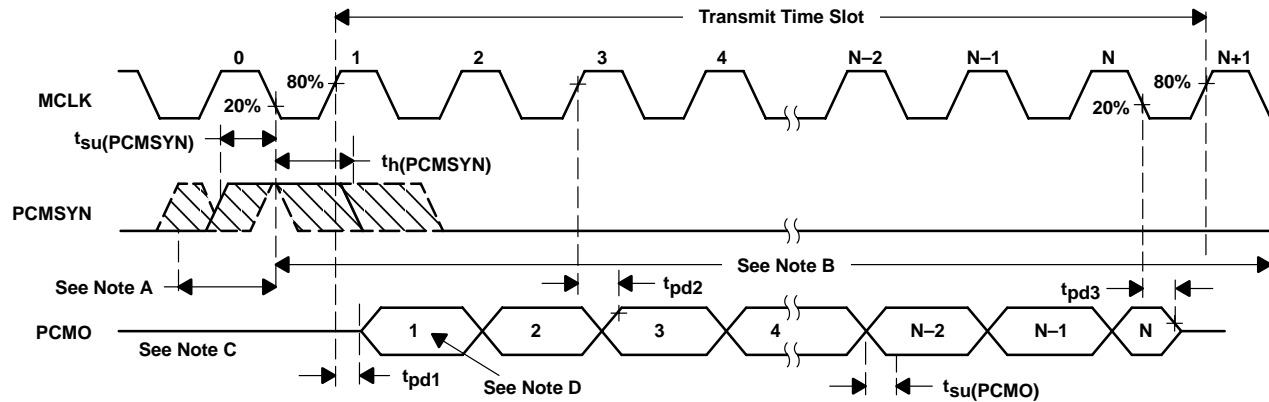

- NOTES: A. This window is allowed for PCMSYN high.
 B. This window is allowed for PCMSYN low ($t_h(PCMSYN)_{max}$ determined by data collision considerations).
 C. Transitions are measured at 50%.
 D. Bit 1 = Most significant bit (MSB), Bit N = Least significant bit (LSB)

Figure 1. Transmit Timing Diagram

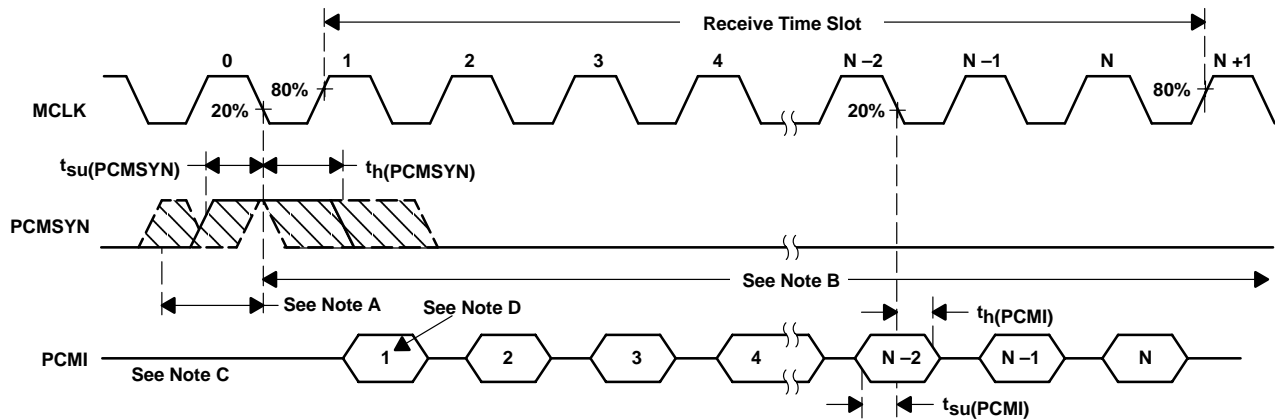

- NOTES: A. This window is allowed for PCMSYN high.
 B. This window is allowed for PCMSYN low.
 C. Transitions are measured at 50%.
 D. Bit 1 = Most significant bit (MSB), Bit N = Least significant bit (LSB)

Figure 2. Receive Timing Diagram

PRINCIPLES OF OPERATION

power-up initialization

An external reset with a minimum pulse width of 500 ns must be applied to the active-low $\overline{\text{RESET}}$ terminal with MCLK active to ensure reset upon power up.

Table 1. Power-Up and Power-Down Power Consumption ($V_{DD} = 2.7\text{ V}$, Earphone Amplifier Loaded)

DEVICE STATUS	MAXIMUM POWER CONSUMPTION
Power-up	16.2 mW
Power-down	81 μW

The loss of MCLK (no transition detected) automatically enters the device into a power-down state with PCMO in the high-impedance state. If an asynchronous power down occurs during a pulse code modulation (PCM) data transmit cycle, the PCM interface remains powered up until the PCM data is completely transferred.

conversion laws

The device can be programmed either for a 13-bit linear or 8-bit (μ -law) companding mode. The companding operation approximates the CCITT G.711 recommendation. The linear mode operation uses a 13-bit two complement format. Linear mode is selected with $\overline{\text{LINSEL}}$ low. $\overline{\text{LINSEL}}$ is high for companding.

transmit operation

microphone input

The microphone input stage is a low-noise differential amplifier. The microphone must be capacitively coupled to the MICIN– and MICIN+ terminals. Pre-amplifier (MIC Amp 1) gain is determined by selection of external resistors R2 and R3. To achieve the recommended gain setting of 23.5 dB for MIC Amp 1, resistor values of $R2 = 34\text{ k}\Omega$ and $R3 = 510\text{ k}\Omega$ are suggested. A 1% tolerance is recommended for all resistors to meet the specification. The recommended range for R2 is 34–100 k Ω . For values above 100 k Ω , the noise performance of the channel is degraded.

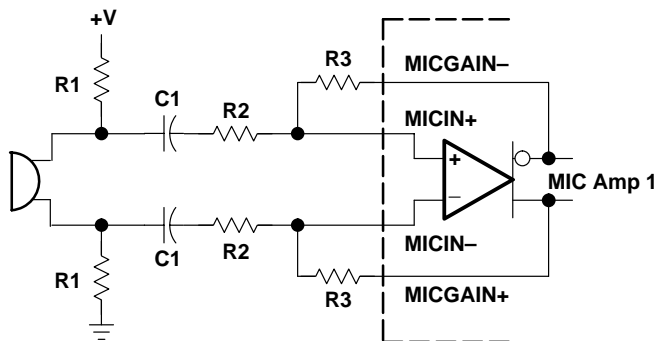

$R1 = 2\text{ k}\Omega$
 $C1 = 0.22\text{ }\mu\text{F}$

$$\text{MIC Amp 1 Gain in dB} = 20 \log \left(\frac{R3}{R2} \right)$$

Figure 3. Typical Microphone Interface

TWL1106 VOICE-BAND AUDIO PROCESSOR (VBAP™)

SLWS094 – JUNE 2001

PRINCIPLES OF OPERATION

microphone mute function

Transmit channel muting can be selected by setting MICMUTE high. Muting provides 80-dB attenuation of the input microphone signal.

receive operation

earphone amplifier

The analog signal is routed to the earphone amplifier differential output (EAROUT– or EAROUT+), which is capable of driving a load as low as 8 Ω. EAROUT is recommended for use as a differential output.

earphone mute function

Receive channel muting can be selected by setting the EARMUTE terminal to high.

receive PCM data format

- Companded mode: 8 bits are received, the MSB first
- Linear mode: 13 bits are received, the MSB first

Table 2. Receive Data Bit Definitions

BIT NO.	COMPANDED MODE	LINEAR MODE
1	CD7	LD12
2	CD6	LD11
3	CD5	LD10
4	CD4	LD9
5	CD3	LD8
6	CD2	LD7
7	CD1	LD6
8	CD0	LD5
9	–	LD4
10	–	LD3
11	–	LD2
12	–	LD1
13	–	LD0
14	–	RXVOL2
15	–	RXVOL1
16	–	RXVOL0

PRINCIPLES OF OPERATION

receive volume control

In linear mode, RXVOL [2:0] PCM data bits are used for volume control according to Table 3. Volume control bits must be sent on PCMI for each 13-bit receive word. In companded mode, volume control is fixed at 0 dB.

Table 3. Volume Control Bit Definition in Linear Mode

RXVOL [2:0]	GAIN SETTING
000	3 dB
001	0 dB
010	–3 dB
011	–6 dB
100	–9 dB
101	–12 dB
110	–15 dB
111	–18 dB

support section

The clock generator and control circuit uses the master clock input (MCLK) to generate internal clocks to drive internal counters, filters, and converters.

clock frequencies and sample rates

A fixed PCMSYN rate of 8 kHz determines the sampling rate. The PCMSYN signal must be derived from the master clock. The divide ratio must be set to 256 for the device to work properly.

TYPICAL CHARACTERISTICS

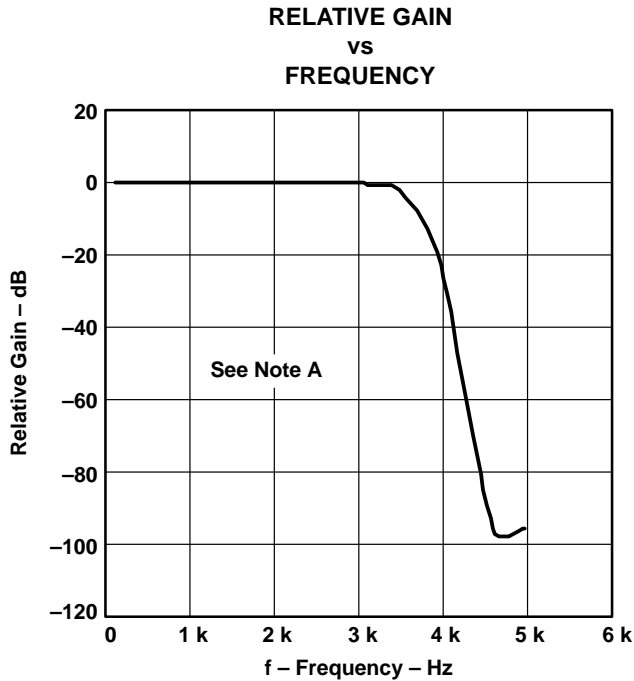

Figure 4

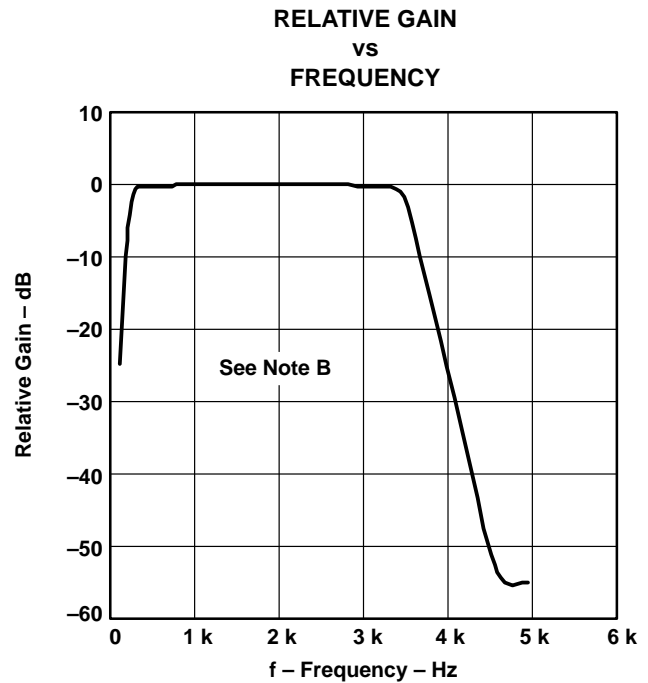

Figure 5

NOTES: A. Transmit channel frequency response shown relative to the gain at a 1.02-kHz input signal in linear mode.
 B. Receive channel frequency response shown relative to the gain at a 1.02-kHz input signal in linear mode.

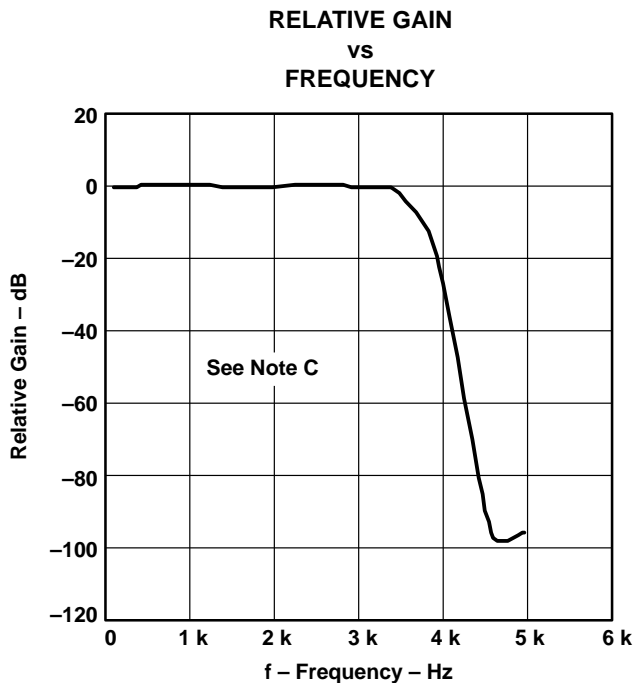

Figure 6

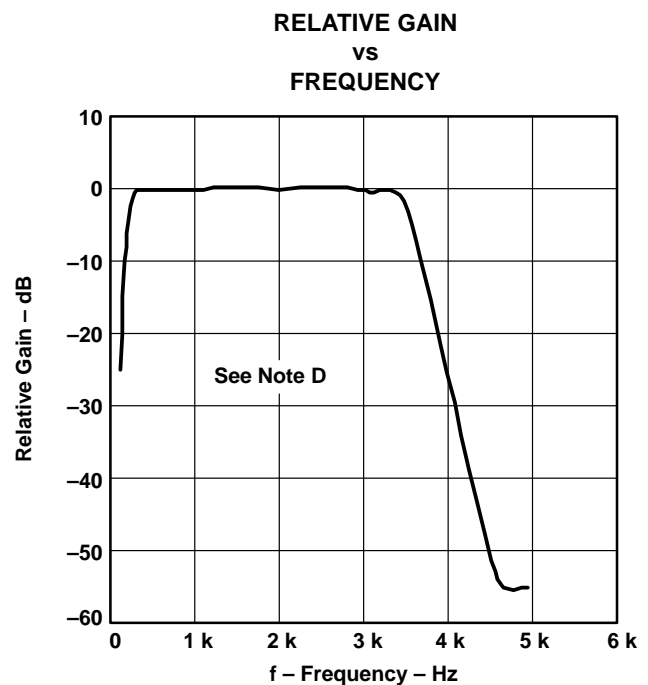

Figure 7

NOTES: C. Transmit channel frequency response shown relative to the gain at a 1.02-kHz input signal in μ -Law mode.
 D. Receive channel frequency response shown relative to the gain at a 1.02-kHz input signal in μ -Law mode.

TYPICAL CHARACTERISTICS

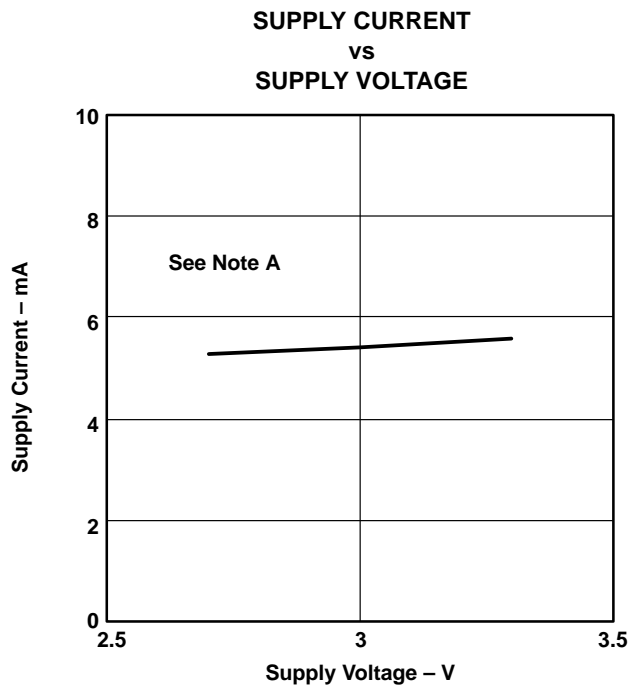

Figure 8

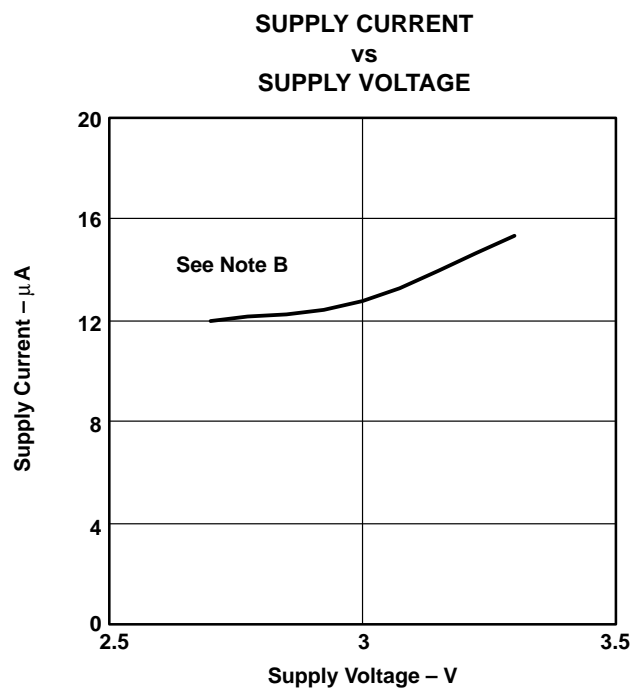

Figure 9

- NOTES: A. Supply current as a function of supply voltage in power-up mode.
 B. Supply current as a function of supply voltage in power-down mode.

TWL1106 VOICE-BAND AUDIO PROCESSOR (VBAP™)

SLWS094 – JUNE 2001

MECHANICAL DATA

PW (R-PDSO-G**)

PLASTIC SMALL-OUTLINE PACKAGE

14 PINS SHOWN

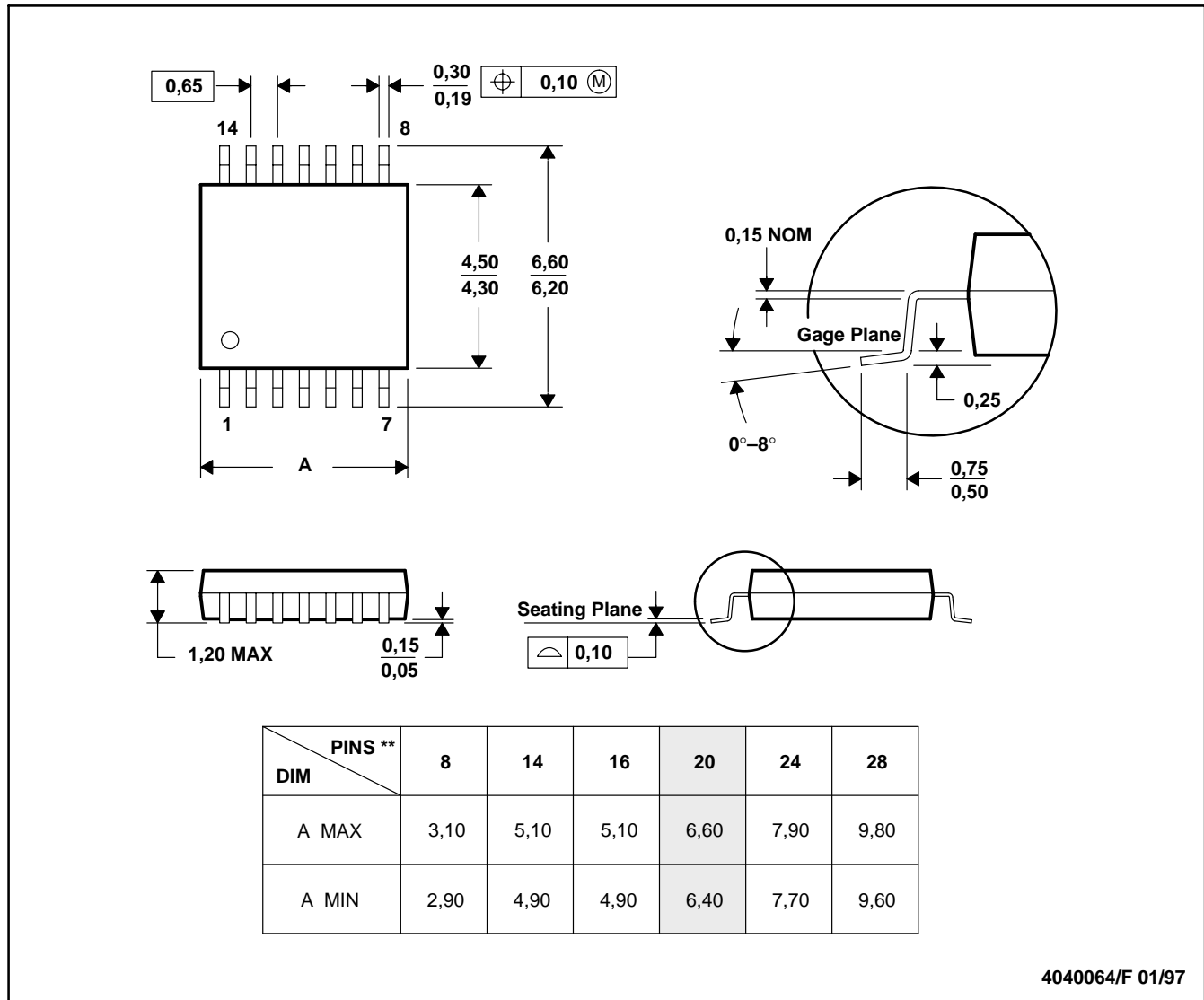

- NOTES: A. All linear dimensions are in millimeters.
 B. This drawing is subject to change without notice.
 C. Body dimensions do not include mold flash or protrusion not to exceed 0,15.
 D. Falls within JEDEC MO-153

IMPORTANT NOTICE

Texas Instruments and its subsidiaries (TI) reserve the right to make changes to their products or to discontinue any product or service without notice, and advise customers to obtain the latest version of relevant information to verify, before placing orders, that information being relied on is current and complete. All products are sold subject to the terms and conditions of sale supplied at the time of order acknowledgment, including those pertaining to warranty, patent infringement, and limitation of liability.

TI warrants performance of its products to the specifications applicable at the time of sale in accordance with TI's standard warranty. Testing and other quality control techniques are utilized to the extent TI deems necessary to support this warranty. Specific testing of all parameters of each device is not necessarily performed, except those mandated by government requirements.

Customers are responsible for their applications using TI components.

In order to minimize risks associated with the customer's applications, adequate design and operating safeguards must be provided by the customer to minimize inherent or procedural hazards.

TI assumes no liability for applications assistance or customer product design. TI does not warrant or represent that any license, either express or implied, is granted under any patent right, copyright, mask work right, or other intellectual property right of TI covering or relating to any combination, machine, or process in which such products or services might be or are used. TI's publication of information regarding any third party's products or services does not constitute TI's approval, license, warranty or endorsement thereof.

Reproduction of information in TI data books or data sheets is permissible only if reproduction is without alteration and is accompanied by all associated warranties, conditions, limitations and notices. Representation or reproduction of this information with alteration voids all warranties provided for an associated TI product or service, is an unfair and deceptive business practice, and TI is not responsible nor liable for any such use.

Resale of TI's products or services with statements different from or beyond the parameters stated by TI for that product or service voids all express and any implied warranties for the associated TI product or service, is an unfair and deceptive business practice, and TI is not responsible nor liable for any such use.

Also see: [Standard Terms and Conditions of Sale for Semiconductor Products](http://www.ti.com/sc/docs/stdterms.htm). www.ti.com/sc/docs/stdterms.htm

Mailing Address:

Texas Instruments
Post Office Box 655303
Dallas, Texas 75265

Copyright © 2001, Texas Instruments Incorporated



PACKAGING INFORMATION

Orderable Device	Status ⁽¹⁾	Package Type	Package Drawing	Pins	Package Qty	Eco Plan ⁽²⁾	Lead/Ball Finish	MSL Peak Temp ⁽³⁾
TWL1106PW	OBSOLETE	TSSOP	PW	20		TBD	Call TI	Call TI
TWL1106PWR	OBSOLETE	TSSOP	PW	20		TBD	Call TI	Call TI

⁽¹⁾ The marketing status values are defined as follows:

ACTIVE: Product device recommended for new designs.

LIFEBUY: TI has announced that the device will be discontinued, and a lifetime-buy period is in effect.

NRND: Not recommended for new designs. Device is in production to support existing customers, but TI does not recommend using this part in a new design.

PREVIEW: Device has been announced but is not in production. Samples may or may not be available.

OBSOLETE: TI has discontinued the production of the device.

⁽²⁾ Eco Plan - The planned eco-friendly classification: Pb-Free (RoHS), Pb-Free (RoHS Exempt), or Green (RoHS & no Sb/Br) - please check <http://www.ti.com/productcontent> for the latest availability information and additional product content details.

TBD: The Pb-Free/Green conversion plan has not been defined.

Pb-Free (RoHS): TI's terms "Lead-Free" or "Pb-Free" mean semiconductor products that are compatible with the current RoHS requirements for all 6 substances, including the requirement that lead not exceed 0.1% by weight in homogeneous materials. Where designed to be soldered at high temperatures, TI Pb-Free products are suitable for use in specified lead-free processes.

Pb-Free (RoHS Exempt): This component has a RoHS exemption for either 1) lead-based flip-chip solder bumps used between the die and package, or 2) lead-based die adhesive used between the die and leadframe. The component is otherwise considered Pb-Free (RoHS compatible) as defined above.

Green (RoHS & no Sb/Br): TI defines "Green" to mean Pb-Free (RoHS compatible), and free of Bromine (Br) and Antimony (Sb) based flame retardants (Br or Sb do not exceed 0.1% by weight in homogeneous material)

⁽³⁾ MSL, Peak Temp. -- The Moisture Sensitivity Level rating according to the JEDEC industry standard classifications, and peak solder temperature.

Important Information and Disclaimer:The information provided on this page represents TI's knowledge and belief as of the date that it is provided. TI bases its knowledge and belief on information provided by third parties, and makes no representation or warranty as to the accuracy of such information. Efforts are underway to better integrate information from third parties. TI has taken and continues to take reasonable steps to provide representative and accurate information but may not have conducted destructive testing or chemical analysis on incoming materials and chemicals. TI and TI suppliers consider certain information to be proprietary, and thus CAS numbers and other limited information may not be available for release.

In no event shall TI's liability arising out of such information exceed the total purchase price of the TI part(s) at issue in this document sold by TI to Customer on an annual basis.

IMPORTANT NOTICE

Texas Instruments Incorporated and its subsidiaries (TI) reserve the right to make corrections, modifications, enhancements, improvements, and other changes to its products and services at any time and to discontinue any product or service without notice. Customers should obtain the latest relevant information before placing orders and should verify that such information is current and complete. All products are sold subject to TI's terms and conditions of sale supplied at the time of order acknowledgment.

TI warrants performance of its hardware products to the specifications applicable at the time of sale in accordance with TI's standard warranty. Testing and other quality control techniques are used to the extent TI deems necessary to support this warranty. Except where mandated by government requirements, testing of all parameters of each product is not necessarily performed.

TI assumes no liability for applications assistance or customer product design. Customers are responsible for their products and applications using TI components. To minimize the risks associated with customer products and applications, customers should provide adequate design and operating safeguards.

TI does not warrant or represent that any license, either express or implied, is granted under any TI patent right, copyright, mask work right, or other TI intellectual property right relating to any combination, machine, or process in which TI products or services are used. Information published by TI regarding third-party products or services does not constitute a license from TI to use such products or services or a warranty or endorsement thereof. Use of such information may require a license from a third party under the patents or other intellectual property of the third party, or a license from TI under the patents or other intellectual property of TI.

Reproduction of TI information in TI data books or data sheets is permissible only if reproduction is without alteration and is accompanied by all associated warranties, conditions, limitations, and notices. Reproduction of this information with alteration is an unfair and deceptive business practice. TI is not responsible or liable for such altered documentation. Information of third parties may be subject to additional restrictions.

Resale of TI products or services with statements different from or beyond the parameters stated by TI for that product or service voids all express and any implied warranties for the associated TI product or service and is an unfair and deceptive business practice. TI is not responsible or liable for any such statements.

TI products are not authorized for use in safety-critical applications (such as life support) where a failure of the TI product would reasonably be expected to cause severe personal injury or death, unless officers of the parties have executed an agreement specifically governing such use. Buyers represent that they have all necessary expertise in the safety and regulatory ramifications of their applications, and acknowledge and agree that they are solely responsible for all legal, regulatory and safety-related requirements concerning their products and any use of TI products in such safety-critical applications, notwithstanding any applications-related information or support that may be provided by TI. Further, Buyers must fully indemnify TI and its representatives against any damages arising out of the use of TI products in such safety-critical applications.

TI products are neither designed nor intended for use in military/aerospace applications or environments unless the TI products are specifically designated by TI as military-grade or "enhanced plastic." Only products designated by TI as military-grade meet military specifications. Buyers acknowledge and agree that any such use of TI products which TI has not designated as military-grade is solely at the Buyer's risk, and that they are solely responsible for compliance with all legal and regulatory requirements in connection with such use.

TI products are neither designed nor intended for use in automotive applications or environments unless the specific TI products are designated by TI as compliant with ISO/TS 16949 requirements. Buyers acknowledge and agree that, if they use any non-designated products in automotive applications, TI will not be responsible for any failure to meet such requirements.

Following are URLs where you can obtain information on other Texas Instruments products and application solutions:

Products

Amplifiers	amplifier.ti.com
Data Converters	dataconverter.ti.com
DLP® Products	www.dlp.com
DSP	dsp.ti.com
Clocks and Timers	www.ti.com/clocks
Interface	interface.ti.com
Logic	logic.ti.com
Power Mgmt	power.ti.com
Microcontrollers	microcontroller.ti.com
RFID	www.ti-rfid.com
RF/IF and ZigBee® Solutions	www.ti.com/lprf

Applications

Audio	www.ti.com/audio
Automotive	www.ti.com/automotive
Broadband	www.ti.com/broadband
Digital Control	www.ti.com/digitalcontrol
Medical	www.ti.com/medical
Military	www.ti.com/military
Optical Networking	www.ti.com/opticalnetwork
Security	www.ti.com/security
Telephony	www.ti.com/telephony
Video & Imaging	www.ti.com/video
Wireless	www.ti.com/wireless

Mailing Address: Texas Instruments, Post Office Box 655303, Dallas, Texas 75265
Copyright © 2009, Texas Instruments Incorporated

Looking for pricing, stock, or lifecycle information?

Click below to explore more details on WIN SOURCE:

 [View TWL1106PWR on WIN SOURCE](#)

 [Texas Instruments](#) Information

Optimize Your Supply Chain with WIN SOURCE Solutions

-  Global Sourcing Solution
-  Obsolete Management
-  Cost Control Management
-  Shortage Management
-  Alternative Solution
-  Excess Inventory Management