



THE DATASHEET OF ST490ABN





ST490AB

Low power high speed RS-485/RS-422 transceiver

Features

- Low supply current: 5 mA max
- -7 V to 12 V common mode input voltage range
- 70 mV typical input hysteresis
- Designed for 25 Mbps operation
- Operate from a single 5 V supply
- ± 4 kV ESD protection
- Current limiting and thermal shutdown for driver overload protection

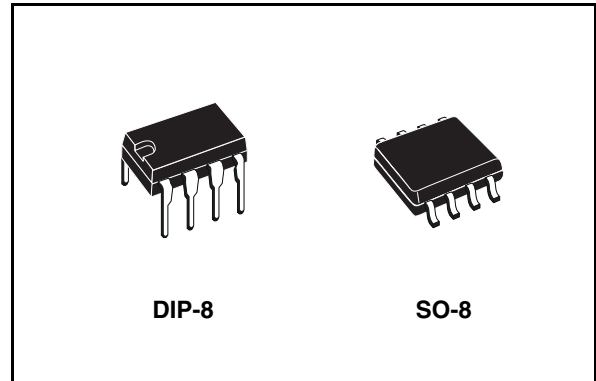

Description

The ST490A is a low power transceiver for RS-485 and RS-422 communications. The device contains one driver and one receiver in full duplex configuration. The ST490A draws 5 mA (typ.) of supply current when unloaded or fully loaded with disabled drivers. It operates from a single 5 V supply.

Driver is short-circuit current limited and is protected against excessive power dissipation by thermal shutdown circuitry that place the driver outputs into a high-impedance state. The receiver input has a fail-safe feature that guarantees a logic high output if both inputs are open circuit.

Table 1. Device summary

Order code	Temperature range	Package	Packaging
ST490ABN	-40 to 85 °C	DIP-8	50 parts per tube / 40 tube per box
ST490ABDR	-40 to 85 °C	SO-8 (tape and reel)	2500 parts per reel

Contents

1	Pin configuration	3
2	Truth tables	4
3	Maximum ratings	5
4	Electrical characteristics	6
5	Test circuit and typical characteristics	8
6	Package mechanical data	12
7	Revision history	16

1 Pin configuration

Figure 1. Pin connections

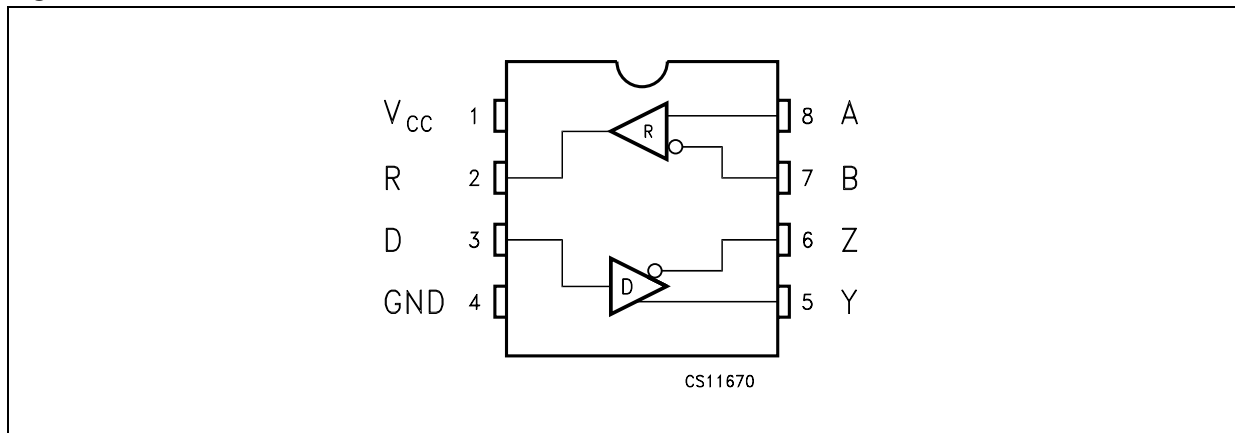

Table 2. Pin description

Pin n°	Symbol	Name and function
1	V _{CC}	Supply voltage
2	RO	Receiver output
3	DI	Driver input
4	GND	Ground
5	Y	Non-inverting driver output
6	Z	Inverting driver output
7	B	Inverting receiver input
8	A	Non-inverting receiver input

2 Truth tables

Table 3. Truth table (driver)

Inputs	Outputs	
DI	Y	Z
L	L	H
H	H	L

Note: X = Don't care; Z = High impedance

Table 4. Truth table (receiver)

Differential inputs	Outputs
A-B	RO
$\geq -0.2V$	H
between -0.2V to 0.2V	?
$\leq 0.2V$	L
OPEN	H

Note: X = Don't care; Z = High impedance

3 Maximum ratings

Table 5. Absolute maximum ratings

Symbol	Parameter	Value	Unit
V_{CC}	Supply voltage	7	V
V_{DI}	Driver input voltage	-0.5 to 7	V
V_Y, V_Z	Driver output voltage	-7.5 to 12.5	V
V_A, V_B	Receiver input voltage	-7.5 to 12.5	V
V_{RO}	Receiver output voltage	-0.3 to ($V_{CC} + 0.3$)	V
ESD	Human body model	3.5	kV

Note: Absolute maximum ratings are those values beyond which damage to the device may occur. Functional operation under these condition is not implied.

4 Electrical characteristics

Table 6. Electrical characteristics

($V_{CC} = 4.5\text{ V to }5.5\text{ V}$, $T_A = -40\text{ to }85\text{ }^\circ\text{C}$, unless otherwise specified. Typical values are referred to $T_A = 25\text{ }^\circ\text{C}$)

Symbol	Parameter	Min.	Typ.	Max.	Unit
I_{SUPPLY}	No load supply current		2	5	mA
C_{IN}	Input capacitance		1.8		pF
C_{YZ}	Driver output capacitance		1.2		pF
C_{OUT}	Output capacitance		2.3		pF

Table 7. Transmitter electrical characteristics

($V_{CC} = 4.5\text{ V to }5.5\text{ V}$, $T_A = -40\text{ to }85\text{ }^\circ\text{C}$, unless otherwise specified. Typical values are referred to $T_A = 25\text{ }^\circ\text{C}$)

Symbol	Parameter	Test conditions	Min.	Typ.	Max.	Unit
V_{OD1}	Differential drive output (no load)				V_{CC}	V
V_{OD2}	Differential drive output (with load)	$R_L = 54\Omega$ (RS-422) (<i>Figure 1</i>)	1.5	2.6	5	V
V_{OD3}	Differential drive output (with load)	$R_L = 100\Omega$ (RS-422) (<i>Figure 1</i>)	2	3		V
ΔV_{OD}	Change in magnitude of driver differential output voltage for complementary output states	$R_L = 54\Omega$ or 100Ω (<i>Figure 1</i>)		0	0.2	V
V_{OC}	Driver common mode output voltage	$R_L = 54\Omega$ (<i>Figure 1</i>)	1		3	V
ΔV_{OC}	Change in magnitude of driver common mode output voltage	$R_L = 54\Omega$ (<i>Figure 1</i>)		0	0.2	V
I_{OFF}	Power off output current	$V_{CC} = 0\text{V}$, $V_O = -7\text{V to }12\text{V}$			± 100	μA
I_{OSD}	Driver short circuit output current	$V_O = -7\text{V to }12\text{V}$	± 35		± 250	mA
V_{IL}	Input logic threshold low				0.8	V
V_{IH}	Input logic threshold high		2			V

Table 8. Receiver electrical characteristics

($V_{CC} = 4.5\text{ V to }5.5\text{ V}$, $T_A = -40\text{ to }85\text{ }^\circ\text{C}$, unless otherwise specified. Typical values are referred to $T_A = 25\text{ }^\circ\text{C}$)

Symbol	Parameter	Test conditions	Min.	Typ.	Max.	Unit
I_{IN1}	Logic input current				± 2.0	μA
I_{IN2}	Input current (A, B)	Other input=0V $V_{CC} = 0\text{ or }5.25\text{V}$	$V_{IN}=12\text{V}$	0.5	1	mA
			$V_{IN}=-7\text{V}$	-0.35	-0.8	mA
V_{TH}	Receiver differential threshold voltage	$V_{CM} = -7\text{V to }12\text{V}$	-0.2		0.2	V
ΔV_{TH}	Receiver input hysteresis	$V_{CM} = 0\text{V}$		70		mV
V_{OH}	Receiver output high voltage	$I_{OUT} = -8\text{mA}$, $V_{ID} = 200\text{mV}$	3.5	4.7		V
V_{OL}	Receiver output low voltage	$I_{OUT} = 8\text{mA}$, $V_{ID} = -200\text{mV}$		0.2	0.4	V
R_{RIN}	Receiver input resistance	$V_{CM} = -7\text{V to }12\text{V}$	12	24		k Ω
I_{OSR}	Receiver short-circuit current	$V_O = 0\text{V to }V_{CC}$	7		95	mA

Table 9. Driver switching characteristics

($V_{CC} = 4.5\text{ V to }5.5\text{ V}$, $T_A = -40\text{ to }85\text{ }^\circ\text{C}$, unless otherwise specified. Typical values are referred to $T_A = 25\text{ }^\circ\text{C}$)

Symbol	Parameter	Test conditions	Min.	Typ.	Max.	Unit
D_R	Maximum data rate	Jitter <5%	25	50		Mbps
t_{PLH} t_{PHL}	Propagation delay input to output	$R_L = 54\Omega$, $C_{L1}=C_{L2}=50\text{pF}$, (Figure 1)		10	16	ns
t_{SKEW}	Differential output delay skew	$R_L = 54\Omega$, $C_{L1}=C_{L2}=50\text{pF}$, (Figure 1)		1	3	ns
t_{TLH} t_{THL}	Rise or fall differential time	$R_L = 54\Omega$, $C_{L1}=C_{L2}=50\text{pF}$, (Figure 1)		8	12	ns

Table 10. Receiver switching characteristics

($V_{CC} = 4.5\text{ V to }5.5\text{ V}$, $T_A = -40\text{ to }85\text{ }^\circ\text{C}$, unless otherwise specified. Typical values are referred to $T_A = 25\text{ }^\circ\text{C}$)

Symbol	Parameter	Test conditions	Min.	Typ.	Max.	Unit
t_{PLH} t_{PHL}	Propagation delay input to output	$C_L = 15\text{pF}$, (Figure 2, Figure 4)		19	30	ns
t_{SKD}	$ t_{PLH} - t_{PHL} $ Receiver output skew	$C_L = 15\text{pF}$, (Figure 2, Figure 4)		1	3	ns
t_{TLH} t_{THL}	Rise or fall time	$C_L = 15\text{pF}$, (Figure 2, Figure 4)		8		ns

5 Test circuit and typical characteristics

Figure 2. Driver DC test load

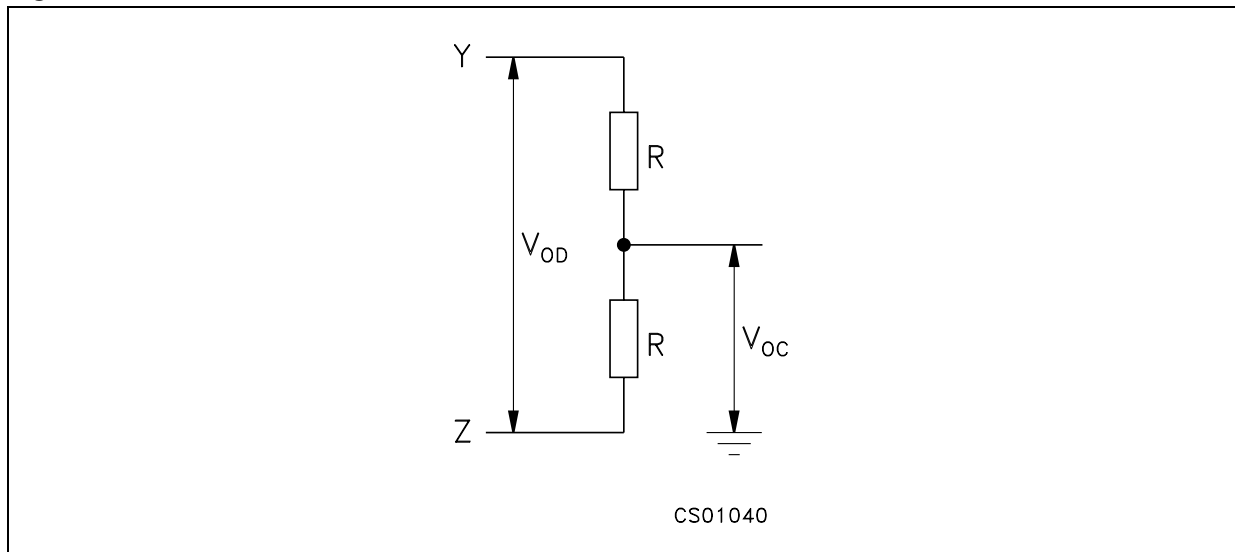

Figure 3. Drive/receiver timing test circuit

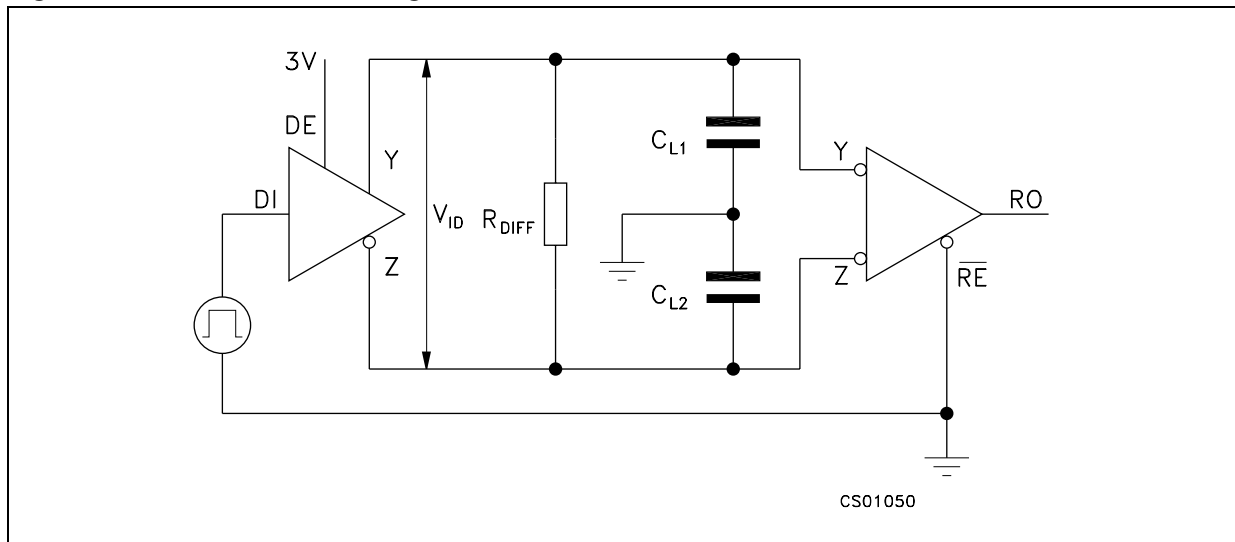

Figure 4. Driver propagation delay

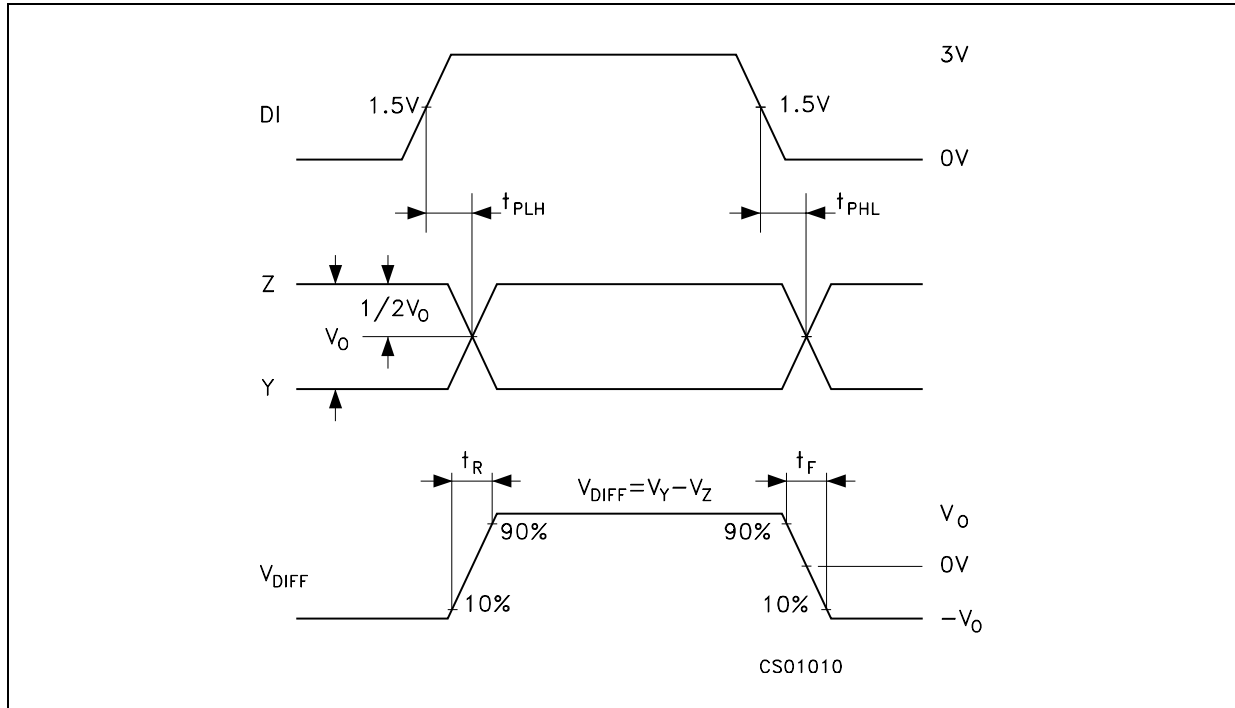

Figure 5. Receiver propagation delay

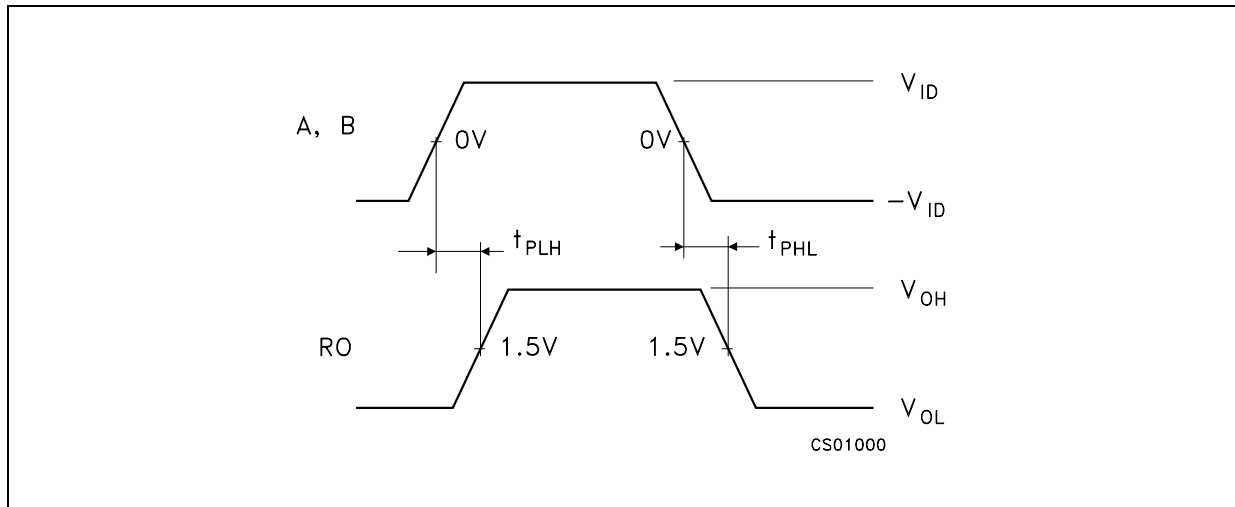

Figure 6. Receiver output current vs. output low voltage (output low)

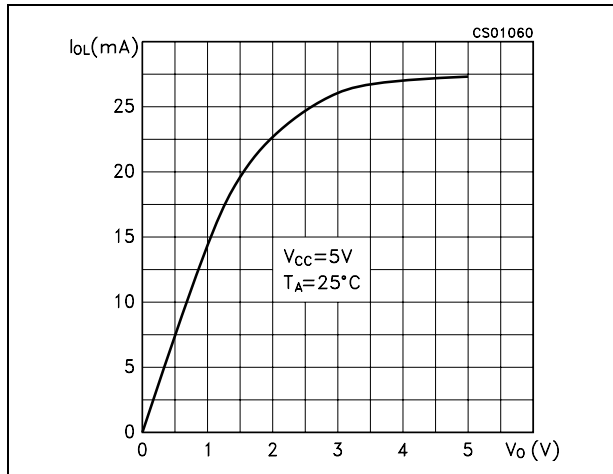

Figure 7. Receiver output current vs. output high voltage (output high)

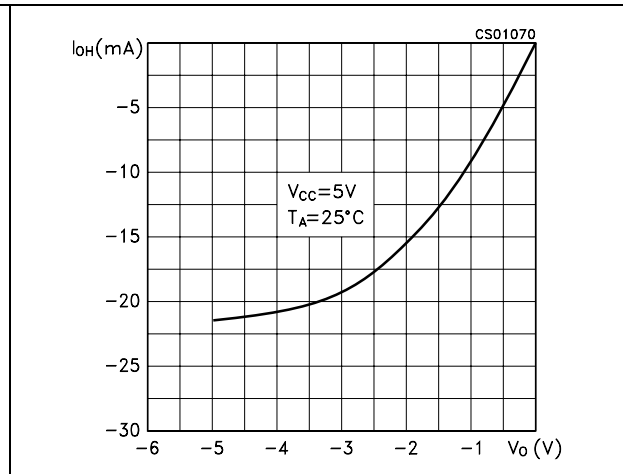

Figure 8. Driver diff. output voltage vs common mode voltage (diff. output low)

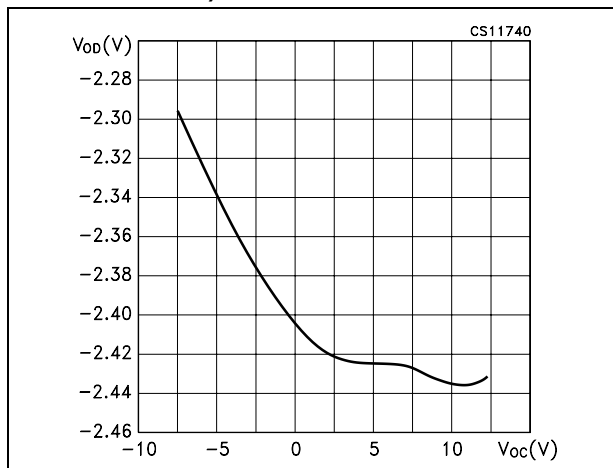

Figure 9. Driver diff. output voltage vs common mode voltage (diff. output high)

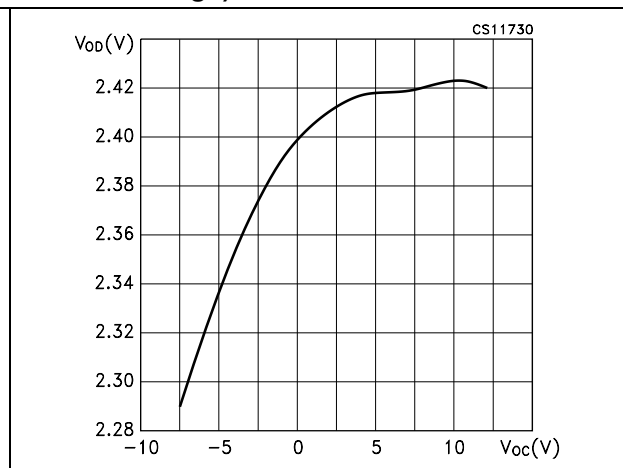

Figure 10. driver short circuit current vs line voltage (output high)

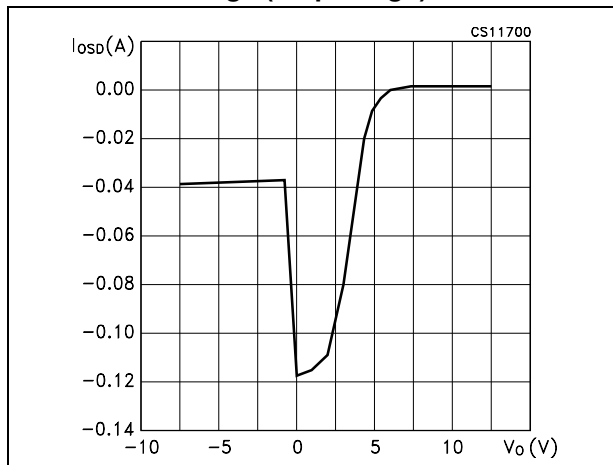

Figure 11. Receiver high level output voltage vs. temperature

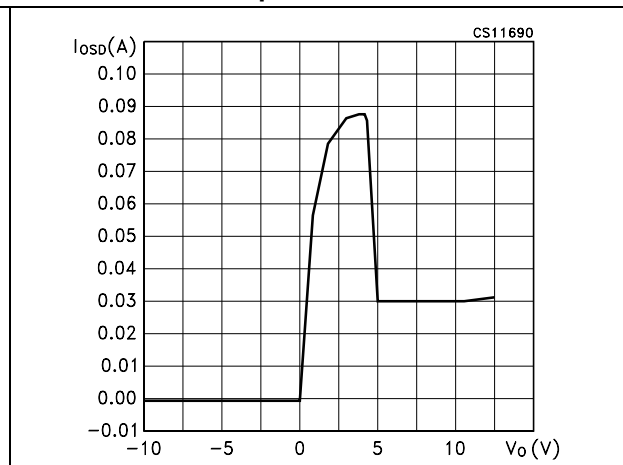
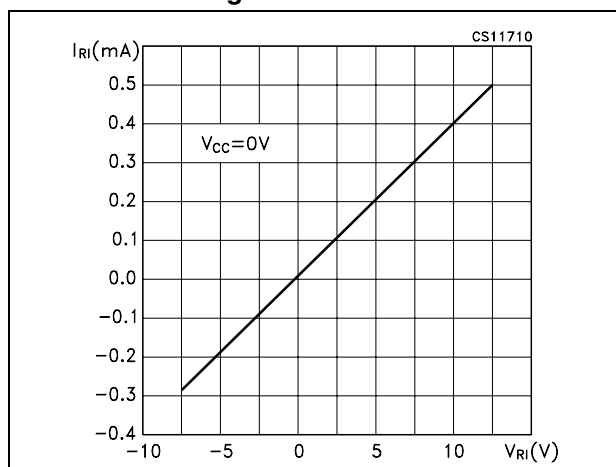

Figure 12. Receiver input current vs input voltage



6 Package mechanical data

In order to meet environmental requirements, ST offers these devices in ECOPACK® packages. These packages have a lead-free second level interconnect. The category of second level interconnect is marked on the package and on the inner box label, in compliance with JEDEC Standard JESD97. The maximum ratings related to soldering conditions are also marked on the inner box label. ECOPACK is an ST trademark. ECOPACK specifications are available at: www.st.com

Plastic DIP-8 mechanical data

Dim.	mm.			inch.		
	Min.	Typ.	Max.	Min.	Typ.	Max.
A		3.3			0.130	
a1	0.7			0.028		
B	1.39		1.65	0.055		0.065
B1	0.91		1.04	0.036		0.041
b		0.5			0.020	
b1	0.38		0.5	0.015		0.020
D			9.8			0.386
E		8.8			0.346	
e		2.54			0.100	
e3		7.62			0.300	
e4		7.62			0.300	
F			7.1			0.280
l			4.8			0.189
L		3.3			0.130	
Z	0.44		1.6	0.017		0.063

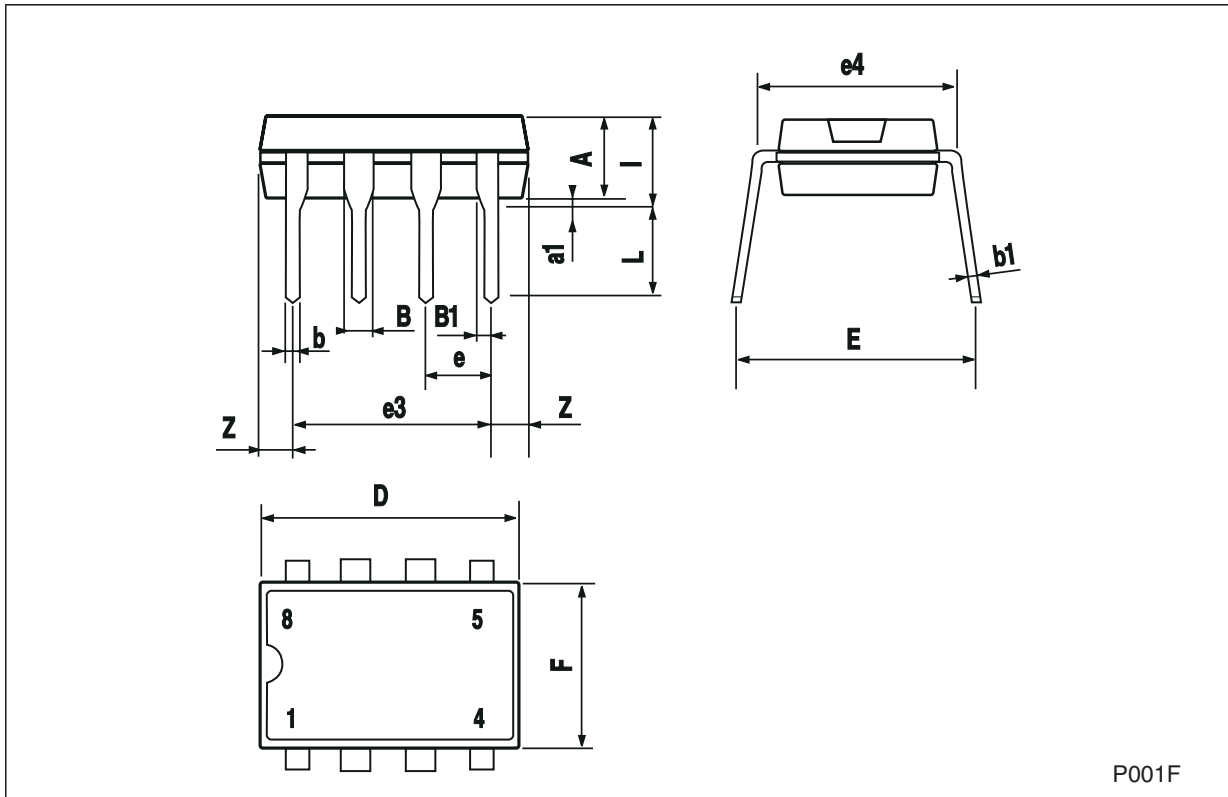

P001F

SO-8 mechanical data

Dim.	mm.			inch.		
	Min.	Typ.	Max.	Min.	Typ.	Max.
A	1.35		1.75	0.053		0.069
A1	0.10		0.25	0.04		0.010
A2	1.10		1.65	0.043		0.065
B	0.33		0.51	0.013		0.020
C	0.19		0.25	0.007		0.010
D	4.80		5.00	0.189		0.197
E	3.80		4.00	0.150		0.157
e		1.27			0.050	
H	5.80		6.20	0.228		0.244
h	0.25		0.50	0.010		0.020
L	0.40		1.27	0.016		0.050
k	8° (max.)					
ddd			0.1			0.04

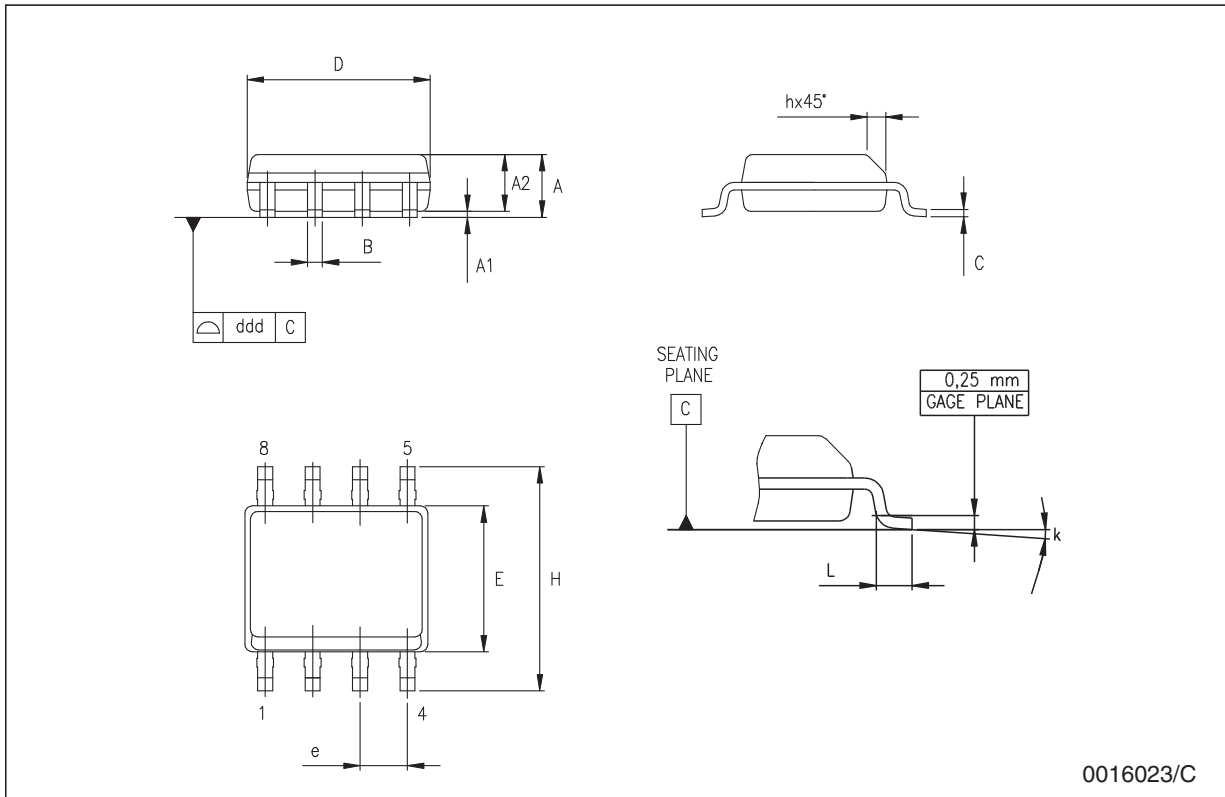

Tape & reel SO-8 mechanical data

Dim.	mm.			inch.		
	Min.	Typ.	Max.	Min.	Typ.	Max.
A			330			12.992
C	12.8		13.2	0.504		0.519
D	20.2			0.795		
N	60			2.362		
T			22.4			0.882
Ao	8.1		8.5	0.319		0.335
Bo	5.5		5.9	0.216		0.232
Ko	2.1		2.3	0.082		0.090
Po	3.9		4.1	0.153		0.161
P	7.9		8.1	0.311		0.319

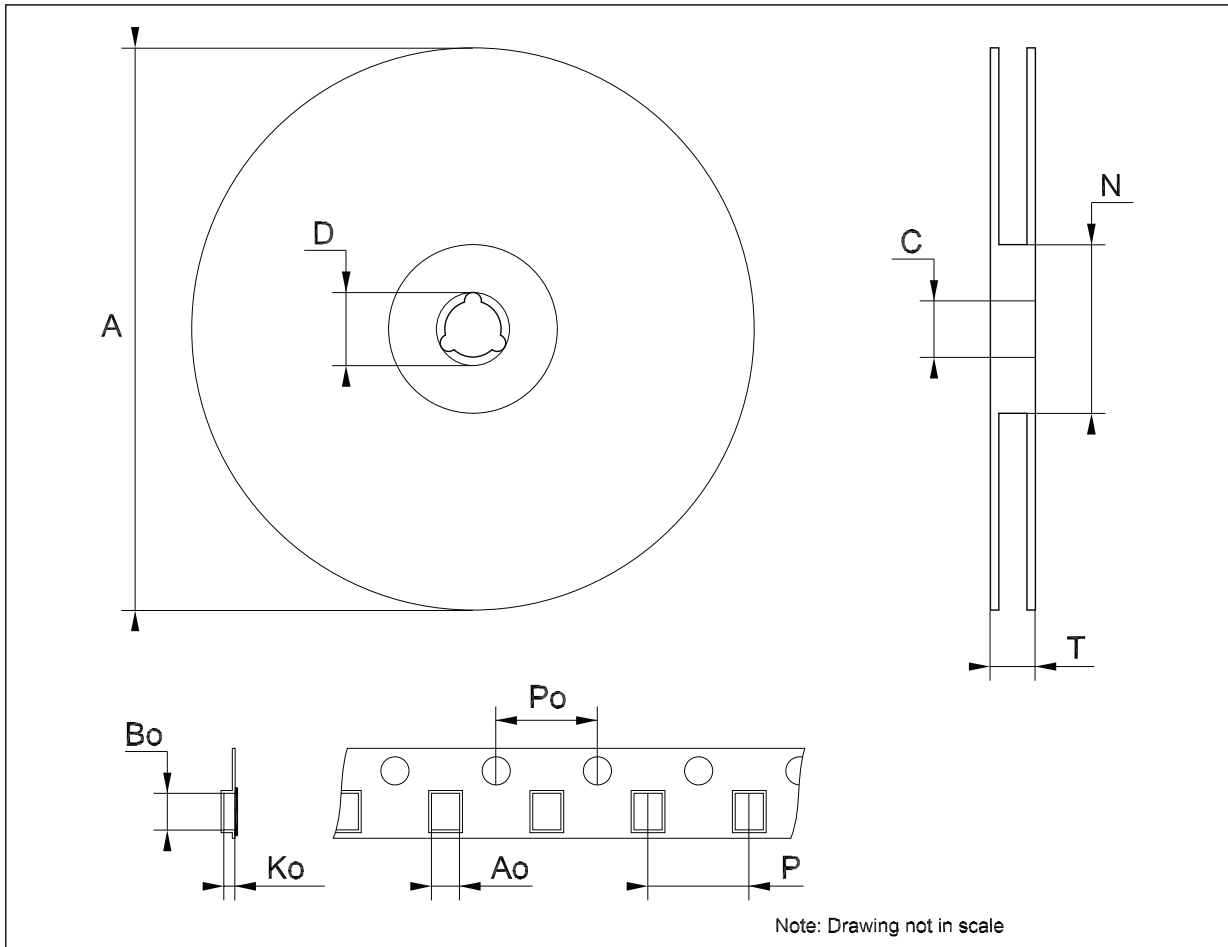

7 Revision history

Table 11. Document revision history

Date	Revision	Changes
06-Jul-2005	2	Typing error on table 2 - pin 5 non-inverting, pin 6 inverting.
04-May-2006	3	Order codes updated.
08-Nov-2007	4	Added: Table 1 .
07-Feb-2008	5	Modified: Table 1 on page 1 .

Please Read Carefully:

Information in this document is provided solely in connection with ST products. STMicroelectronics NV and its subsidiaries ("ST") reserve the right to make changes, corrections, modifications or improvements, to this document, and the products and services described herein at any time, without notice.

All ST products are sold pursuant to ST's terms and conditions of sale.

Purchasers are solely responsible for the choice, selection and use of the ST products and services described herein, and ST assumes no liability whatsoever relating to the choice, selection or use of the ST products and services described herein.

No license, express or implied, by estoppel or otherwise, to any intellectual property rights is granted under this document. If any part of this document refers to any third party products or services it shall not be deemed a license grant by ST for the use of such third party products or services, or any intellectual property contained therein or considered as a warranty covering the use in any manner whatsoever of such third party products or services or any intellectual property contained therein.

UNLESS OTHERWISE SET FORTH IN ST'S TERMS AND CONDITIONS OF SALE ST DISCLAIMS ANY EXPRESS OR IMPLIED WARRANTY WITH RESPECT TO THE USE AND/OR SALE OF ST PRODUCTS INCLUDING WITHOUT LIMITATION IMPLIED WARRANTIES OF MERCHANTABILITY, FITNESS FOR A PARTICULAR PURPOSE (AND THEIR EQUIVALENTS UNDER THE LAWS OF ANY JURISDICTION), OR INFRINGEMENT OF ANY PATENT, COPYRIGHT OR OTHER INTELLECTUAL PROPERTY RIGHT.

UNLESS EXPRESSLY APPROVED IN WRITING BY AN AUTHORIZED ST REPRESENTATIVE, ST PRODUCTS ARE NOT RECOMMENDED, AUTHORIZED OR WARRANTED FOR USE IN MILITARY, AIR CRAFT, SPACE, LIFE SAVING, OR LIFE SUSTAINING APPLICATIONS, NOR IN PRODUCTS OR SYSTEMS WHERE FAILURE OR MALFUNCTION MAY RESULT IN PERSONAL INJURY, DEATH, OR SEVERE PROPERTY OR ENVIRONMENTAL DAMAGE. ST PRODUCTS WHICH ARE NOT SPECIFIED AS "AUTOMOTIVE GRADE" MAY ONLY BE USED IN AUTOMOTIVE APPLICATIONS AT USER'S OWN RISK.

Resale of ST products with provisions different from the statements and/or technical features set forth in this document shall immediately void any warranty granted by ST for the ST product or service described herein and shall not create or extend in any manner whatsoever, any liability of ST.

ST and the ST logo are trademarks or registered trademarks of ST in various countries.

Information in this document supersedes and replaces all information previously supplied.

The ST logo is a registered trademark of STMicroelectronics. All other names are the property of their respective owners.

© 2008 STMicroelectronics - All rights reserved

STMicroelectronics group of companies

Australia - Belgium - Brazil - Canada - China - Czech Republic - Finland - France - Germany - Hong Kong - India - Israel - Italy - Japan - Malaysia - Malta - Morocco - Singapore - Spain - Sweden - Switzerland - United Kingdom - United States of America

www.st.com

Looking for pricing, stock, or lifecycle information?

Click below to explore more details on WIN SOURCE:

- ⊖ [View ST490ABN on WIN SOURCE](#)
- ⊖ [STMicroelectronics Information](#)

Optimize Your Supply Chain with WIN SOURCE Solutions

- ✓ Global Sourcing Solution
- ✓ Obsolete Management
- ✓ Cost Control Management
- ✓ Shortage Management
- ✓ Alternative Solution
- ✓ Excess Inventory Management