



**THE DATASHEET OF  
CY8C27243-12PVXE**



## Automotive: CY8C27243, CY8C27443, and CY8C27643



### Features

#### ■ Powerful Harvard Architecture Processor

- M8C Processor Speeds to 12 MHz
- 8x8 Multiply, 32-Bit Accumulate
- Low Power at High Speed
- 4.75V to 5.25V Operating Voltage
- Extended Temp. Range: -40°C to +105°C

#### ■ Advanced Peripherals (PSoC Blocks)

- 12 Rail-to-Rail Analog PSoC Blocks Provide:
  - Up to 14-Bit ADCs
  - Up to 9-Bit DACs
  - Programmable Gain Amplifiers
  - Programmable Filters and Comparators
- 8 Digital PSoC Blocks Provide:
  - 8- to 32-Bit Timers, Counters, and PWMs
  - CRC and PRS Modules
  - Up to 2 Full-Duplex UARTs
  - Multiple SPI™ Masters or Slaves
  - Connectable to all GPIO Pins
- Complex Peripherals by Combining Blocks

#### ■ Precision, Programmable Clocking

- Internal ±4% 24 MHz Oscillator
- 24 MHz with Optional 32.768 kHz Crystal
- Optional External Oscillator, up to 24 MHz
- Internal Oscillator for Watchdog and Sleep

#### ■ Flexible On-Chip Memory

- 16K Bytes Flash Program Storage
- 256 Bytes SRAM Data Storage
- In-System Serial Programming (ISSP)
- Partial Flash Updates
- Flexible Protection Modes

#### ■ Programmable Pin Configurations

- 25 mA Sink on All GPIO
- Pull Up, Pull Down, High Z, Strong, or Open Drain Drive Modes on all GPIO
- Up to 12 Analog Inputs on GPIO
- Four 30 mA Analog Outputs on GPIO
- Configurable Interrupt on All GPIO

#### ■ Additional System Resources

- I<sup>2</sup>C™ Slave, Master, and Multi-Master to 400 kHz
- Watchdog and Sleep Timers
- User-Configurable Low Voltage Detection
- Integrated Supervisory Circuit
- On-Chip Precision Voltage Reference

#### ■ Complete Development Tools

- Free Development Software (PSoC™ Designer)
- Full-Featured, In-Circuit Emulator and Programmer
- Full Speed Emulation
- Complex Breakpoint Structure
- 128K Bytes Trace Memory

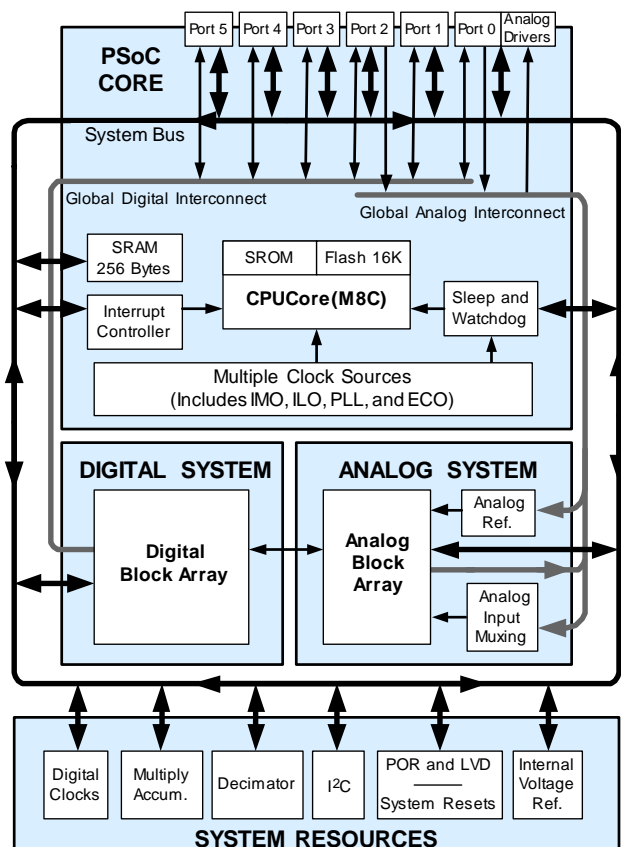

### PSoC® Functional Overview

The PSoC® family consists of many *Mixed-Signal Array with On-Chip Controller* devices. These devices are designed to replace multiple traditional MCU-based system components with one, low cost single-chip programmable device. PSoC devices include configurable blocks of analog and digital logic, as well as programmable interconnects. This architecture allows the user to create customized peripheral configurations that match the requirements of each individual application. Additionally, a fast CPU, Flash program memory, SRAM data memory, and configurable IO are included in a range of convenient pinouts and packages.

The PSoC architecture, as illustrated on the left, is comprised of four main areas: PSoC Core, Digital System, Analog System, and System Resources. Configurable global busing allows all device resources to be combined into a complete custom system. The CY8C27x43 automotive family can have up to five IO ports that connect to the global digital and analog interconnects, providing access to 8 digital blocks and 12 analog blocks.

#### The PSoC Core

The PSoC Core is a powerful engine that supports a rich feature set. The core includes a CPU, memory, clocks, and configurable GPIO (General Purpose IO).

The M8C CPU core is a powerful processor with speeds up to 12 MHz, providing a two MIPS 8-bit Harvard architecture micro-

processor. The CPU utilizes an interrupt controller with 17 vectors, to simplify programming of real time embedded events. Program execution is timed and protected using the included Sleep and Watch Dog Timers (WDT).

Memory includes 16 KB of Flash for program storage and 256 bytes of SRAM for data storage. Program Flash utilizes four protection levels on blocks of 64 bytes, allowing customized software IP protection.

The PSoC device incorporates flexible internal clock generators, including a 24 MHz IMO (internal main oscillator) accurate to 4% over temperature and voltage. A low power 32 kHz ILO (internal low speed oscillator) is provided for the Sleep timer and WDT. If crystal accuracy is desired, the ECO (32.768 kHz external crystal oscillator) is available for use as a Real Time Clock (RTC) and can optionally generate a crystal-accurate 24 MHz system clock using a PLL. The clocks, together with programmable clock dividers (as a System Resource), provide the flexibility to integrate almost any timing requirement into the PSoC device.

PSoC GPIOs provide connection to the CPU, digital and analog resources of the device. Each pin's drive mode may be selected from eight options, allowing great flexibility in external interfacing. Every pin also has the capability to generate a system interrupt on high level, low level, and change from last read.

## The Digital System

The Digital System is composed of 8 digital PSoC blocks. Each block is an 8-bit resource that can be used alone or combined with other blocks to form 8, 16, 24, and 32-bit peripherals, which are called user module references.

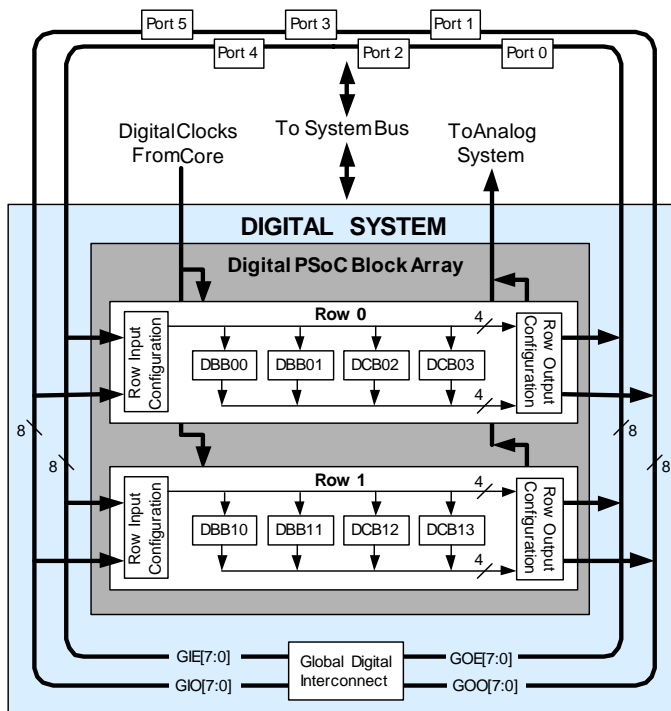

Digital System Block Diagram

Digital peripheral configurations include those listed below.

- PWMs (8 to 32 bit)
- PWMs with Dead Band (8 to 32 bit)
- Counters (8 to 32 bit)
- Timers (8 to 32 bit)
- UART 8 bit with selectable parity (up to 2)
- SPI Master and Slave (up to 2)
- I2C Slave and Multi-master (1 available as a System Resource)
- Cyclical Redundancy Checker/Generator (8 to 32 bit)
- IrDA (up to 2)
- Pseudo Random Sequence Generators (8 to 32 bit)

The digital blocks can be connected to any GPIO through a series of global buses that can route any signal to any pin. The buses also allow for signal multiplexing and for performing logic operations. This configurability frees your designs from the constraints of a fixed peripheral controller.

Digital blocks are provided in rows of four, where the number of blocks varies by PSoC device family. This allows you the optimum choice of system resources for your application. Family resources are shown in the table titled "PSoC Device Characteristics" on page 3.

## The Analog System

The Analog System is composed of 12 configurable blocks, each comprised of an opamp circuit allowing the creation of complex analog signal flows. Analog peripherals are very flexible and can be customized to support specific application requirements. Some of the more common PSoC analog functions (most available as user modules) are listed below.

- Analog-to-digital converters (up to 4, with 6- to 14-bit resolution, selectable as Incremental, Delta Sigma, and SAR)
- Filters (2, 4, 6, and 8 pole band-pass, low-pass, and notch)
- Amplifiers (up to 4, with selectable gain to 48x)
- Instrumentation amplifiers (up to 2, with selectable gain to 93x)
- Comparators (up to 4, with 16 selectable thresholds)
- DACs (up to 4, with 6- to 9-bit resolution)
- Multiplying DACs (up to 4, with 6- to 9-bit resolution)
- High current output drivers (four with 40 mA drive as a PSoC Core resource)
- 1.3V reference (as a System Resource)
- DTMF Dialer
- Modulators
- Correlators
- Peak Detectors
- Many other topologies possible

Analog blocks are provided in columns of three, which include one CT (Continuous Time) and two SC (Switched Capacitor) blocks, as shown in the figure below.

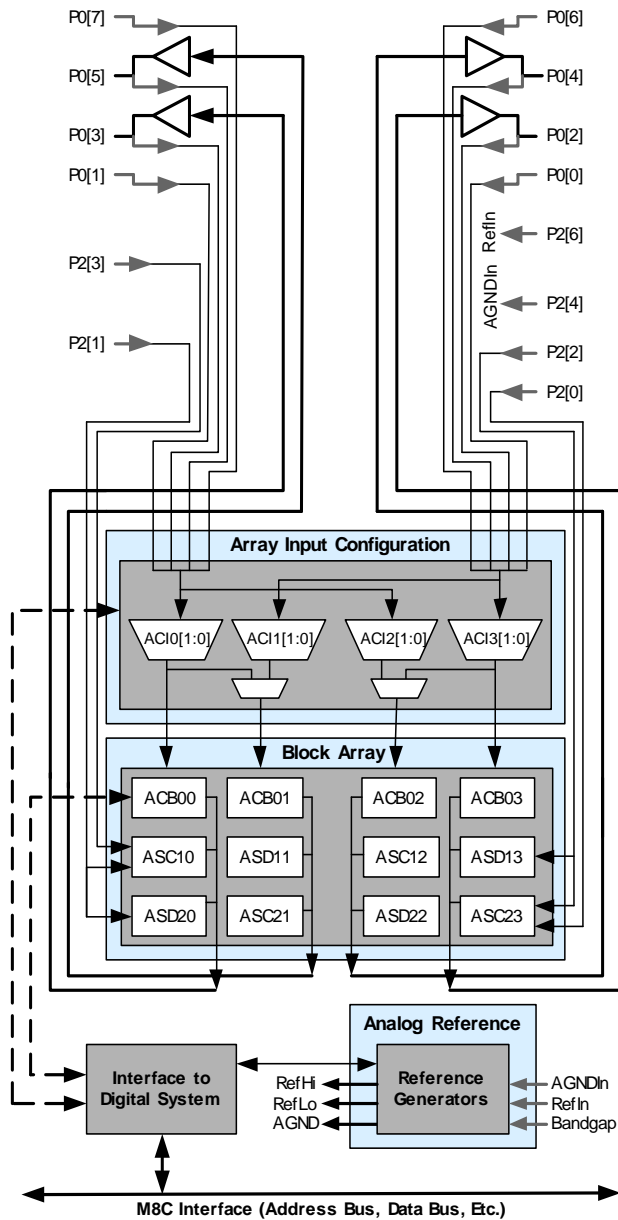

Analog System Block Diagram

### Additional System Resources

System Resources, some of which have been previously listed, provide additional capability useful to complete systems. Additional resources include a multiplier, decimator, switch mode pump, low voltage detection, and power on reset. Brief statements describing the merits of each system resource are presented below.

- Digital clock dividers provide three customizable clock frequencies for use in applications. The clocks can be routed to both the digital and analog systems. Additional clocks can be generated using digital PSOC blocks as clock dividers.
- A multiply accumulate (MAC) provides a fast 8-bit multiplier with 32-bit accumulate to assist in both general math as well as digital filters.
- The decimator provides a custom hardware filter for digital signal processing applications including the creation of Delta Sigma ADCs.
- The I2C module provides 100 and 400 kHz communication over two wires. Slave, master, and multi-master modes are all supported.
- Low Voltage Detection (LVD) interrupts can signal the application of falling voltage levels, while the advanced POR (Power On Reset) circuit eliminates the need for a system supervisor.
- An internal 1.3V reference provides an absolute reference for the analog system, including ADCs and DACs.

### PSoC Device Characteristics

Depending on your PSOC device characteristics, the digital and analog systems can have 16, 8, or 4 digital blocks and 12, 6, or 4 analog blocks. The following table lists the resources available for specific PSOC device groups. The PSOC device covered by this data sheet is highlighted below.

#### PSoC Device Characteristics

PSoC Part Number	Digital IO	Digital Rows	Digital Blocks	Analog Inputs	Analog Outputs	Analog Columns	Analog Blocks	SRAM Size	Flash Size
CY8C29x66	up to 64	4	16	12	4	4	12	2K	32K
<b>CY8C27x43</b>	<b>up to 44</b>	<b>2</b>	<b>8</b>	<b>12</b>	<b>4</b>	<b>4</b>	<b>12</b>	<b>256 Bytes</b>	<b>16K</b>
CY8C24x94	56	1	4	48	2	2	6	1K	16K
CY8C24x23A	up to 24	1	4	12	2	2	6	256 Bytes	4K
CY8C21x34	up to 28	1	4	28	0	2	4 <sup>a</sup>	512 Bytes	8K
CY8C21x23	16	1	4	8	0	2	4 <sup>a</sup>	256 Bytes	4K
CY8C20x34	up to 28	0	0	28	0	0	3 <sup>b</sup>	512 Bytes	8K

a. Limited analog functionality.  
 b. Two analog blocks and one CapSense.

## Getting Started

The quickest path to understanding the PSoC silicon is by reading this data sheet and using the PSoC Designer Integrated Development Environment (IDE). This data sheet is an overview of the PSoC integrated circuit and presents specific pin, register, and electrical specifications. For in-depth information, along with detailed programming information, reference the *PSoC Mixed-Signal Array Technical Reference Manual*.

For up-to-date Ordering, Packaging, and Electrical Specification information, reference the latest PSoC device data sheets on the web at <http://www.cypress.com/psoc>.

## Development Kits

Development Kits are available from the following distributors: Digi-Key, Avnet, Arrow, and Future. The Cypress Online Store contains development kits, C compilers, and all accessories for PSoC development. Go to the Cypress Online Store web site at <http://www.cypress.com>, click the Online Store shopping cart icon at the bottom of the web page, and click *PSoC (Programmable System-on-Chip)* to view a current list of available items.

## Technical Training Modules

Free PSoC technical training modules are available for users new to PSoC. Training modules cover designing, debugging, advanced analog and CapSense. Go to <http://www.cypress.com/techtrain>.

## Consultants

Certified PSoC Consultants offer everything from technical assistance to completed PSoC designs. To contact or become a PSoC Consultant go to <http://www.cypress.com>, click on Design Support located on the left side of the web page, and select CYPros Consultants.

## Technical Support

PSoC application engineers take pride in fast and accurate response. They can be reached with a 4-hour guaranteed response at <http://www.cypress.com/support/login.cfm>.

## Application Notes

A long list of application notes will assist you in every aspect of your design effort. To view the PSoC application notes, go to the <http://www.cypress.com> web site and select Application Notes under the Design Resources list located in the center of the web page. Application notes are listed by date by default.

## Development Tools

PSoC Designer is a Microsoft® Windows-based, integrated development environment for the Programmable System-on-Chip (PSoC) devices. The PSoC Designer IDE and application runs on Windows NT 4.0, Windows 2000, Windows Millennium (Me), or Windows XP. (Reference the PSoC Designer Functional Flow diagram below.)

PSoC Designer helps the customer to select an operating configuration for the PSoC, write application code that uses the PSoC, and debug the application. This system provides design database management by project, an integrated debugger with In-Circuit Emulator, in-system programming support, and the macro assembler for the CPUs.

PSoC Designer also supports a high-level C language compiler developed specifically for the devices in the family.

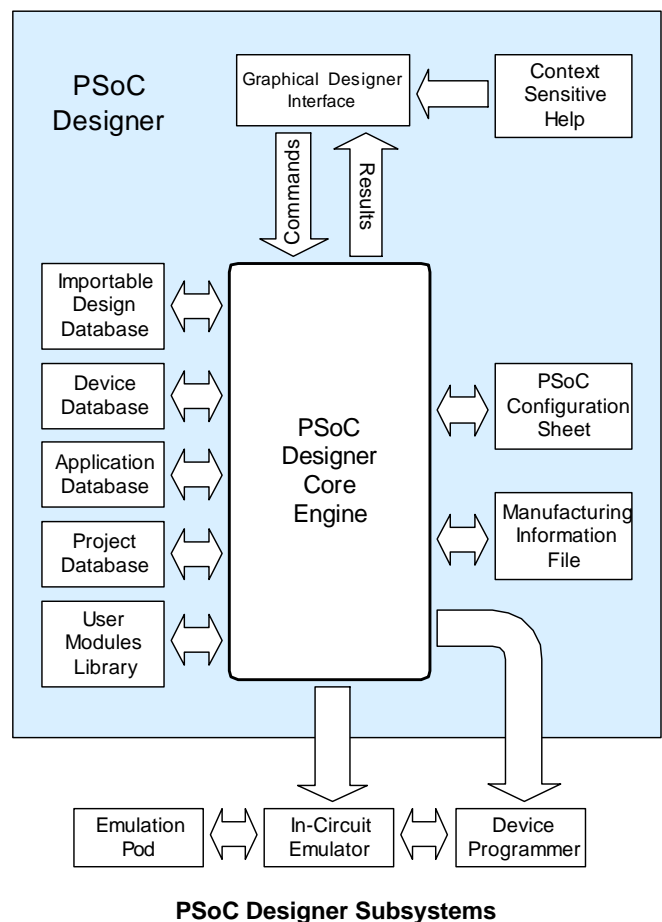

## PSoC Designer Software Subsystems

### *Device Editor*

The Device Editor subsystem allows the user to select different onboard analog and digital components called user modules using the PSoC blocks. Examples of user modules are ADCs, DACs, Amplifiers, and Filters.

The device editor also supports easy development of multiple configurations and dynamic reconfiguration. Dynamic configuration allows for changing configurations at run time.

PSoC Designer sets up power-on initialization tables for selected PSoC block configurations and creates source code for an application framework. The framework contains software to operate the selected components and, if the project uses more than one operating configuration, contains routines to switch between different sets of PSoC block configurations at run time. PSoC Designer can print out a configuration sheet for given project configuration for use during application programming in conjunction with the Device Data Sheet. Once the framework is generated, the user can add application-specific code to flesh out the framework. It's also possible to change the selected components and regenerate the framework.

### *Design Browser*

The Design Browser allows users to select and import preconfigured designs into the user's project. Users can easily browse a catalog of preconfigured designs to facilitate time-to-design. Examples provided in the tools include a 300-baud modem, LIN Bus master and slave, fan controller, and magnetic card reader.

### *Application Editor*

In the Application Editor you can edit your C language and Assembly language source code. You can also assemble, compile, link, and build.

**Assembler.** The macro assembler allows the assembly code to be merged seamlessly with C code. The link libraries automatically use absolute addressing or can be compiled in relative mode, and linked with other software modules to get absolute addressing.

**C Language Compiler.** A C language compiler is available that supports Cypress MicroSystems' PSoC family devices. Even if you have never worked in the C language before, the product quickly allows you to create complete C programs for the PSoC family devices.

The embedded, optimizing C compiler provides all the features of C tailored to the PSoC architecture. It comes complete with embedded libraries providing port and bus operations, standard keypad and display support, and extended math functionality.

### *Debugger*

The PSoC Designer Debugger subsystem provides hardware in-circuit emulation, allowing the designer to test the program in a physical system while providing an internal view of the PSoC device. Debugger commands allow the designer to read and program and read and write data memory, read and write IO registers, read and write CPU registers, set and clear breakpoints, and provide program run, halt, and step control. The debugger also allows the designer to create a trace buffer of registers and memory locations of interest.

### *Online Help System*

The online help system displays online, context-sensitive help for the user. Designed for procedural and quick reference, each functional subsystem has its own context-sensitive help. This system also provides tutorials and links to FAQs and an Online Support Forum to aid the designer in getting started.

## Hardware Tools

### *In-Circuit Emulator*

A low cost, high functionality ICE (In-Circuit Emulator) is available for development support. This hardware has the capability to program single devices.

The emulator consists of a base unit that connects to the PC by way of the parallel or USB port. The base unit is universal and will operate with all PSoC devices. Emulation pods for each device family are available separately. The emulation pod takes the place of the PSoC device in the target board and performs full speed (24 MHz) operation.

## Designing with User Modules

The development process for the PSoC device differs from that of a traditional fixed function microprocessor. The configurable analog and digital hardware blocks give the PSoC architecture a unique flexibility that pays dividends in managing specification change during development and later by lowering inventory costs. These configurable resources, called PSoC Blocks, have the ability to implement a wide variety of user-selectable functions. Each block has several registers that determine its function and connectivity to other blocks, multiplexers, buses and to the IO pins. Iterative development cycles permit you to adapt the hardware as well as the software. This substantially lowers the risk that you will have to select a different part to meet the final design requirements.

To speed the development process, the PSoC Designer Integrated Development Environment (IDE) provides a library of pre-built, pre-tested hardware peripheral functions, called “User Modules.” User modules make selecting and implementing peripheral devices simple, and come in analog, digital, and mixed signal varieties. The standard User Module library contains over 50 common peripherals such as ADCs, DACs Timers, Counters, UARTs, and other not-so common peripherals such as DTMF Generators and Bi-Quad analog filter sections.

Each user module establishes the basic register settings that implement the selected function. It also provides parameters that allow you to tailor its precise configuration to your particular application. For example, a Pulse Width Modulator User Module configures one or more digital PSoC blocks, one for each 8 bits of resolution. The user module parameters permit you to establish the pulse width and duty cycle. User modules also provide tested software to cut your development time. The user module application programming interface (API) provides high-level functions to control and respond to hardware events at run-time. The API also provides optional interrupt service routines that you can adapt as needed.

The API functions are documented in user module data sheets that are viewed directly in the PSoC Designer IDE. These data sheets explain the internal operation of the user module and provide performance specifications. Each data sheet describes the use of each user module parameter and documents the setting of each register controlled by the user module.

The development process starts when you open a new project and bring up the Device Editor, a graphical user interface (GUI) for configuring the hardware. You pick the user modules you need for your project and map them onto the PSoC blocks with point-and-click simplicity. Next, you build signal chains by interconnecting user modules to each other and the IO pins. At this stage, you also configure the clock source connections and enter parameter values directly or by selecting values from drop-down menus. When you are ready to test the hardware configuration or move on to developing code for the project, you perform the “Generate Application” step. This causes PSoC Designer to generate source code that automatically configures the device to your specification and provides the high-level user module API functions.

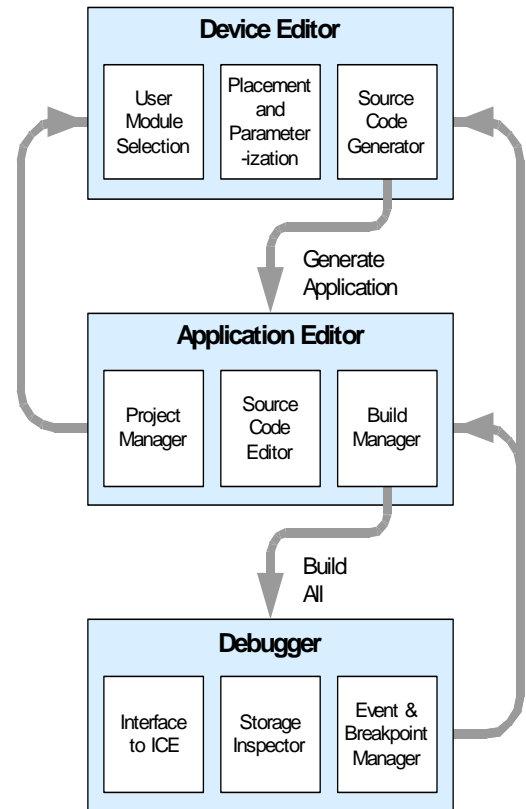

### User Module and Source Code Development Flows

The next step is to write your main program, and any sub-routines using PSoC Designer’s Application Editor subsystem. The Application Editor includes a Project Manager that allows you to open the project source code files (including all generated code files) from a hierarchal view. The source code editor provides syntax coloring and advanced edit features for both C and assembly language. File search capabilities include simple string searches and recursive “grep-style” patterns. A single mouse click invokes the Build Manager. It employs a professional-strength “makefile” system to automatically analyze all file dependencies and run the compiler and assembler as necessary. Project-level options control optimization strategies used by the compiler and linker. Syntax errors are displayed in a console window. Double clicking the error message takes you directly to the offending line of source code. When all is correct, the linker builds a HEX file image suitable for programming.

The last step in the development process takes place inside the PSoC Designer’s Debugger subsystem. The Debugger downloads the HEX image to the In-Circuit Emulator (ICE) where it runs at full speed. Debugger capabilities rival those of systems costing many times more. In addition to traditional single-step, run-to-breakpoint and watch-variable features, the Debugger provides a large trace buffer and allows you define complex breakpoint events that include monitoring address and data bus values, memory locations and external signals.

## Document Conventions

### Acronyms Used

The following table lists the acronyms that are used in this document.

Acronym	Description
AC	alternating current
ADC	analog-to-digital converter
API	application programming interface
CPU	central processing unit
CT	continuous time
DAC	digital-to-analog converter
DC	direct current
ECO	external crystal oscillator
EEPROM	electrically erasable programmable read-only memory
FSR	full scale range
GPIO	general purpose IO
GUI	graphical user interface
HBM	human body model
ICE	in-circuit emulator
ILO	internal low speed oscillator
IMO	internal main oscillator
IO	input/output
IPOR	imprecise power on reset
LSb	least-significant bit
LVD	low voltage detect
MSb	most-significant bit
PC	program counter
PLL	phase-locked loop
POR	power on reset
PPOR	precision power on reset
PSoC®	Programmable System-on-Chip™
PWM	pulse width modulator
SC	switched capacitor
SRAM	static random access memory

### Units of Measure

A units of measure table is located in the Electrical Specifications section. [Table 3-1 on page 14](#) lists all the abbreviations used to measure the PSoC devices.

### Numeric Naming

Hexidecimal numbers are represented with all letters in uppercase with an appended lowercase 'h' (for example, '14h' or '3Ah'). Hexidecimal numbers may also be represented by a '0x' prefix, the C coding convention. Binary numbers have an appended lowercase 'b' (e.g., '01010100b' or '01000011b'). Numbers not indicated by an 'h' or 'b' are decimal.

## Table of Contents

For an in depth discussion and more information on your PSoC device, obtain the *PSoC Mixed-Signal Array Technical Reference Manual*. This document encompasses and is organized into the following chapters and sections.

<b>1. Pin Information</b>	<b>8</b>
1.1 Pinouts	8
1.1.1 20-Pin Part Pinout	8
1.1.2 28-Pin Part Pinout	9
1.1.3 48-Pin Part Pinout	10
<b>2. Register Reference</b>	<b>11</b>
2.1 Register Conventions	11
2.2 Register Mapping Tables	11
<b>3. Electrical Specifications</b>	<b>14</b>
3.1 Absolute Maximum Ratings	15
3.2 Operating Temperature	15
3.3 DC Electrical Characteristics	16
3.3.1 DC Chip-Level Specifications	16
3.3.2 DC General Purpose IO Specifications	16
3.3.3 DC Operational Amplifier Specifications	17
3.3.4 DC Low Power Comparator Specifications	17
3.3.5 DC Analog Output Buffer Specifications	18
3.3.6 DC Analog Reference Specifications	19
3.3.7 DC Analog PSoC Block Specifications	20
3.3.8 DC POR and LVD Specifications	20
3.3.9 DC Programming Specifications	21
3.4 AC Electrical Characteristics	22
3.4.1 AC Chip-Level Specifications	22
3.4.2 AC General Purpose IO Specifications	24
3.4.3 AC Operational Amplifier Specifications	25
3.4.4 AC Low Power Comparator Specifications	27
3.4.5 AC Digital Block Specifications	27
3.4.6 AC Analog Output Buffer Specifications	28
3.4.7 AC External Clock Specifications	28
3.4.8 AC Programming Specifications	29
3.4.9 AC I2C Specifications	29
<b>4. Packaging Information</b>	<b>30</b>
4.1 Packaging Dimensions	30
4.2 Thermal Impedances	32
4.3 Capacitance on Crystal Pins	32
4.4 Solder Reflow Peak Temperature	32
<b>5. Ordering Information</b>	<b>33</b>
5.1 Ordering Code Definitions	33
<b>6. Sales and Service Information</b>	<b>34</b>
6.1 Revision History	34
6.2 Copyrights and Flash Code Protection	34

# 1. Pin Information



This chapter describes, lists, and illustrates the CY8C27x43 automotive PSoC device pins and pinout configurations.

## 1.1 Pinouts

The CY8C27x43 automotive PSoC device is available in a variety of packages which are listed and illustrated in the following tables. Every port pin (labeled with a "P") is capable of Digital IO. However, Vss, Vdd, and XRES are not capable of Digital IO.

### 1.1.1 20-Pin Part Pinout

**Table 1-1. 20-Pin Part Pinout (SSOP)**

Pin No.	Type		Pin Name	Description
	Digital	Analog		
1	IO	I	P0[7]	Analog column mux input.
2	IO	IO	P0[5]	Analog column mux input and column output.
3	IO	IO	P0[3]	Analog column mux input and column output.
4	IO	I	P0[1]	Analog column mux input.
5	Power		Vss	Ground connection.
6	IO		P1[7]	I2C Serial Clock (SCL).
7	IO		P1[5]	I2C Serial Data (SDA).
8	IO		P1[3]	
9	IO		P1[1]	Crystal Input (XTALin), I2C Serial Clock (SCL), ISSP-SCLK*.
10	Power		Vss	Ground connection.
11	IO		P1[0]	Crystal Output (XTALout), I2C Serial Data (SDA), ISSP-SDATA*.
12	IO		P1[2]	
13	IO		P1[4]	Optional External Clock Input (EXTCLK).
14	IO		P1[6]	
15	Input		XRES	Active high external reset with internal pull down.
16	IO	I	P0[0]	Analog column mux input.
17	IO	IO	P0[2]	Analog column mux input and column output.
18	IO	IO	P0[4]	Analog column mux input and column output.
19	IO	I	P0[6]	Analog column mux input.
20	Power		Vdd	Supply voltage.

**CY8C27243 20-Pin PSoC Device**

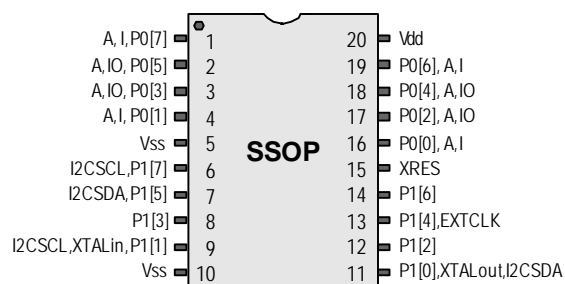

**LEGEND:** A = Analog, I = Input, and O = Output.

\* These are the ISSP pins, which are not High Z at POR (Power On Reset). See the *PSoC Mixed-Signal Array Technical Reference Manual* for details.

1.1.2 28-Pin Part Pinout

Table 1-2. 28-Pin Part Pinout (SSOP)

Pin No.	Type		Pin Name	Description
	Digital	Analog		
1	IO	I	P0[7]	Analog column mux input.
2	IO	IO	P0[5]	Analog column mux input and column output.
3	IO	IO	P0[3]	Analog column mux input and column output.
4	IO	I	P0[1]	Analog column mux input.
5	IO		P2[7]	
6	IO		P2[5]	
7	IO	I	P2[3]	Direct switched capacitor block input.
8	IO	I	P2[1]	Direct switched capacitor block input.
9	Power		Vss	Ground connection.
10	IO		P1[7]	I2C Serial Clock (SCL).
11	IO		P1[5]	I2C Serial Data (SDA).
12	IO		P1[3]	
13	IO		P1[1]	Crystal Input (XTALin), I2C Serial Clock (SCL), ISSP-SCLK*.
14	Power		Vss	Ground connection.
15	IO		P1[0]	Crystal Output (XTALout), I2C Serial Data (SDA), ISSP-SDATA*.
16	IO		P1[2]	
17	IO		P1[4]	Optional External Clock Input (EXTCLK).
18	IO		P1[6]	
19	Input		XRES	Active high external reset with internal pull down.
20	IO	I	P2[0]	Direct switched capacitor block input.
21	IO	I	P2[2]	Direct switched capacitor block input.
22	IO		P2[4]	External Analog Ground (AGND).
23	IO		P2[6]	External Voltage Reference (VRef).
24	IO	I	P0[0]	Analog column mux input.
25	IO	IO	P0[2]	Analog column mux input and column output.
26	IO	IO	P0[4]	Analog column mux input and column output.
27	IO	I	P0[6]	Analog column mux input.
28	Power		Vdd	Supply voltage.

CY8C27443 28-Pin PSoC Device

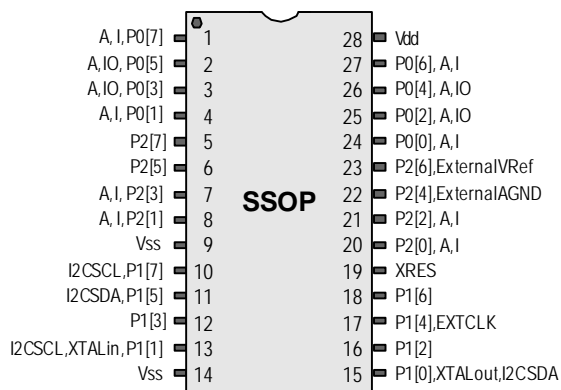

**LEGEND:** A = Analog, I = Input, and O = Output.  
 \* These are the ISSP pins, which are not High Z at POR (Power On Reset). See the PSoC Mixed-Signal Array Technical Reference Manual for details.

1.1.3 48-Pin Part Pinout

Table 1-3. 48-Pin Part Pinout (SSOP)

Pin No.	Type		Pin Name	Description
	Digital	Analog		
1	IO	I	P0[7]	Analog column mux input.
2	IO	IO	P0[5]	Analog column mux input and column output.
3	IO	IO	P0[3]	Analog column mux input and column output.
4	IO	I	P0[1]	Analog column mux input.
5	IO		P2[7]	
6	IO		P2[5]	
7	IO	I	P2[3]	Direct switched capacitor block input.
8	IO	I	P2[1]	Direct switched capacitor block input.
9	IO		P4[7]	
10	IO		P4[5]	
11	IO		P4[3]	
12	IO		P4[1]	
13	Power		Vss	Ground connection.
14	IO		P3[7]	
15	IO		P3[5]	
16	IO		P3[3]	
17	IO		P3[1]	
18	IO		P5[3]	
19	IO		P5[1]	
20	IO		P1[7]	I2C Serial Clock (SCL).
21	IO		P1[5]	I2C Serial Data (SDA).
22	IO		P1[3]	
23	IO		P1[1]	Crystal Input (XTALin), I2C Serial Clock (SCL), ISSP-SCLK*.
24	Power		Vss	Ground connection.
25	IO		P1[0]	Crystal Output (XTALout), I2C Serial Data (SDA), ISSP-SDATA*.
26	IO		P1[2]	
27	IO		P1[4]	Optional External Clock Input (EXTCLK).
28	IO		P1[6]	
29	IO		P5[0]	
30	IO		P5[2]	
31	IO		P3[0]	
32	IO		P3[2]	
33	IO		P3[4]	
34	IO		P3[6]	
35	Input		XRES	Active high external reset with internal pull down.
36	IO		P4[0]	
37	IO		P4[2]	
38	IO		P4[4]	
39	IO		P4[6]	
40	IO	I	P2[0]	Direct switched capacitor block input.
41	IO	I	P2[2]	Direct switched capacitor block input.
42	IO		P2[4]	External Analog Ground (AGND).
43	IO		P2[6]	External Voltage Reference (VRef).
44	IO	I	P0[0]	Analog column mux input.
45	IO	IO	P0[2]	Analog column mux input and column output.
46	IO	IO	P0[4]	Analog column mux input and column output.
47	IO	I	P0[6]	Analog column mux input.
48	Power		Vdd	Supply voltage.

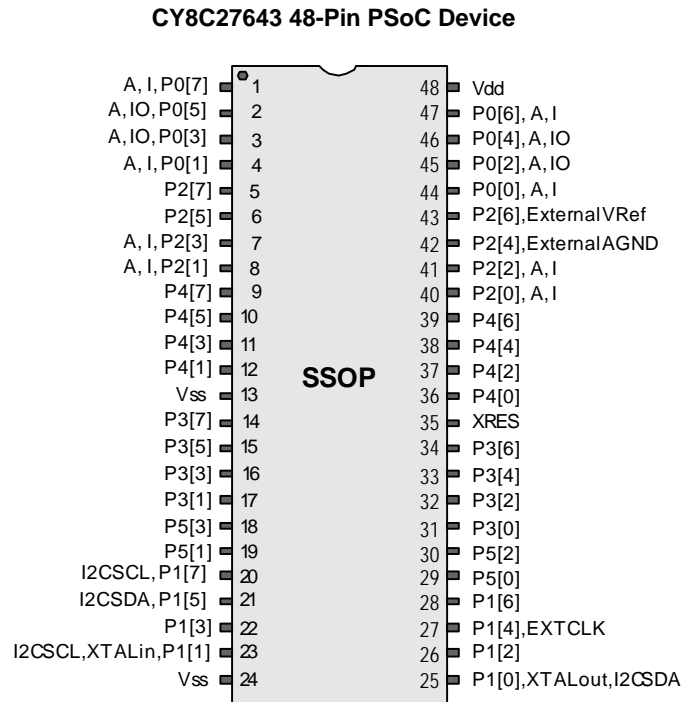

LEGEND: A = Analog, I = Input, and O = Output.

\* These are the ISSP pins, which are not High Z at POR (Power On Reset). See the PSoC Mixed-Signal Array Technical Reference Manual for details.

## 2. Register Reference



This chapter lists the registers of the CY8C27x43 automotive PSoC devices. For detailed register information, reference the *PSoC Mixed-Signal Array Technical Reference Manual*.

### 2.1 Register Conventions

The register conventions specific to this section are listed in the following table.

Convention	Description
R	Read register or bit(s)
W	Write register or bit(s)
L	Logical register or bit(s)
C	Clearable register or bit(s)
#	Access is bit specific

### 2.2 Register Mapping Tables

The PSoC device has a total register address space of 512 bytes. The register space is referred to as IO space and is divided into two banks. The XO1 bit in the Flag register (CPU\_F) determines which bank the user is currently in. When the XO1 bit is set the user is in Bank 1.

**Note** In the following register mapping tables, blank fields are Reserved and should not be accessed.

Register Map Bank 0 Table: User Space

Name	Addr (0,Hex)	Access	Name	Addr (0,Hex)	Access	Name	Addr (0,Hex)	Access	Name	Addr (0,Hex)	Access
PRT0DR	00	RW		40		ASC10CR0	80	RW		C0	
PRT0IE	01	RW		41		ASC10CR1	81	RW		C1	
PRT0GS	02	RW		42		ASC10CR2	82	RW		C2	
PRT0DM2	03	RW		43		ASC10CR3	83	RW		C3	
PRT1DR	04	RW		44		ASD11CR0	84	RW		C4	
PRT1IE	05	RW		45		ASD11CR1	85	RW		C5	
PRT1GS	06	RW		46		ASD11CR2	86	RW		C6	
PRT1DM2	07	RW		47		ASD11CR3	87	RW		C7	
PRT2DR	08	RW		48		ASC12CR0	88	RW		C8	
PRT2IE	09	RW		49		ASC12CR1	89	RW		C9	
PRT2GS	0A	RW		4A		ASC12CR2	8A	RW		CA	
PRT2DM2	0B	RW		4B		ASC12CR3	8B	RW		CB	
PRT3DR	0C	RW		4C		ASD13CR0	8C	RW		CC	
PRT3IE	0D	RW		4D		ASD13CR1	8D	RW		CD	
PRT3GS	0E	RW		4E		ASD13CR2	8E	RW		CE	
PRT3DM2	0F	RW		4F		ASD13CR3	8F	RW		CF	
PRT4DR	10	RW		50		ASD20CR0	90	RW		D0	
PRT4IE	11	RW		51		ASD20CR1	91	RW		D1	
PRT4GS	12	RW		52		ASD20CR2	92	RW		D2	
PRT4DM2	13	RW		53		ASD20CR3	93	RW		D3	
PRT5DR	14	RW		54		ASC21CR0	94	RW		D4	
PRT5IE	15	RW		55		ASC21CR1	95	RW		D5	
PRT5GS	16	RW		56		ASC21CR2	96	RW	I2C_CFG	D6	RW
PRT5DM2	17	RW		57		ASC21CR3	97	RW	I2C_SCR	D7	#
	18			58		ASD22CR0	98	RW	I2C_DR	D8	RW
	19			59		ASD22CR1	99	RW	I2C_MSCR	D9	#
	1A			5A		ASD22CR2	9A	RW	INT_CLR0	DA	RW
	1B			5B		ASD22CR3	9B	RW	INT_CLR1	DB	RW
	1C			5C		ASC23CR0	9C	RW		DC	
	1D			5D		ASC23CR1	9D	RW	INT_CLR3	DD	RW
	1E			5E		ASC23CR2	9E	RW	INT_MSK3	DE	RW
	1F			5F		ASC23CR3	9F	RW		DF	
DBB00DR0	20	#	AMX_IN	60	RW		A0		INT_MSK0	E0	RW
DBB00DR1	21	W		61			A1		INT_MSK1	E1	RW
DBB00DR2	22	RW		62			A2		INT_VC	E2	RC
DBB00CR0	23	#	ARF_CR	63	RW		A3		RES_WDT	E3	W
DBB01DR0	24	#	CMP_CR0	64	#		A4		DEC_DH	E4	RC
DBB01DR1	25	W	ASY_CR	65	#		A5		DEC_DL	E5	RC
DBB01DR2	26	RW	CMP_CR1	66	RW		A6		DEC_CR0	E6	RW
DBB01CR0	27	#		67			A7		DEC_CR1	E7	RW
DCB02DR0	28	#		68			A8		MUL_X	E8	W
DCB02DR1	29	W		69			A9		MUL_Y	E9	W
DCB02DR2	2A	RW		6A			AA		MUL_DH	EA	R
DCB02CR0	2B	#		6B			AB		MUL_DL	EB	R
DCB03DR0	2C	#		6C			AC		ACC_DR1	EC	RW
DCB03DR1	2D	W		6D			AD		ACC_DR0	ED	RW
DCB03DR2	2E	RW		6E			AE		ACC_DR3	EE	RW
DCB03CR0	2F	#		6F			AF		ACC_DR2	EF	RW
DBB10DR0	30	#	ACB00CR3	70	RW	RD10RI	B0	RW		F0	
DBB10DR1	31	W	ACB00CR0	71	RW	RD10SYN	B1	RW		F1	
DBB10DR2	32	RW	ACB00CR1	72	RW	RD10IS	B2	RW		F2	
DBB10CR0	33	#	ACB00CR2	73	RW	RD10LT0	B3	RW		F3	
DBB11DR0	34	#	ACB01CR3	74	RW	RD10LT1	B4	RW		F4	
DBB11DR1	35	W	ACB01CR0	75	RW	RD10RO0	B5	RW		F5	
DBB11DR2	36	RW	ACB01CR1	76	RW	RD10RO1	B6	RW		F6	
DBB11CR0	37	#	ACB01CR2	77	RW		B7		CPU_F	F7	RL
DCB12DR0	38	#	ACB02CR3	78	RW	RD11RI	B8	RW		F8	
DCB12DR1	39	W	ACB02CR0	79	RW	RD11SYN	B9	RW		F9	
DCB12DR2	3A	RW	ACB02CR1	7A	RW	RD11IS	BA	RW		FA	
DCB12CR0	3B	#	ACB02CR2	7B	RW	RD11LT0	BB	RW		FB	
DCB13DR0	3C	#	ACB03CR3	7C	RW	RD11LT1	BC	RW		FC	
DCB13DR1	3D	W	ACB03CR0	7D	RW	RD11RO0	BD	RW		FD	
DCB13DR2	3E	RW	ACB03CR1	7E	RW	RD11RO1	BE	RW	CPU_SCR1	FE	#
DCB13CR0	3F	#	ACB03CR2	7F	RW		BF		CPU_SCR0	FF	#

Blank fields are Reserved and should not be accessed. # Access is bit specific.

Register Map Bank 1 Table: Configuration Space

Name	Addr (1,Hex)	Access	Name	Addr (1,Hex)	Access	Name	Addr (1,Hex)	Access	Name	Addr (1,Hex)	Access
PRT0DM0	00	RW		40		ASC10CR0	80	RW		C0	
PRT0DM1	01	RW		41		ASC10CR1	81	RW		C1	
PRT0IC0	02	RW		42		ASC10CR2	82	RW		C2	
PRT0IC1	03	RW		43		ASC10CR3	83	RW		C3	
PRT1DM0	04	RW		44		ASD11CR0	84	RW		C4	
PRT1DM1	05	RW		45		ASD11CR1	85	RW		C5	
PRT1IC0	06	RW		46		ASD11CR2	86	RW		C6	
PRT1IC1	07	RW		47		ASD11CR3	87	RW		C7	
PRT2DM0	08	RW		48		ASC12CR0	88	RW		C8	
PRT2DM1	09	RW		49		ASC12CR1	89	RW		C9	
PRT2IC0	0A	RW		4A		ASC12CR2	8A	RW		CA	
PRT2IC1	0B	RW		4B		ASC12CR3	8B	RW		CB	
PRT3DM0	0C	RW		4C		ASD13CR0	8C	RW		CC	
PRT3DM1	0D	RW		4D		ASD13CR1	8D	RW		CD	
PRT3IC0	0E	RW		4E		ASD13CR2	8E	RW		CE	
PRT3IC1	0F	RW		4F		ASD13CR3	8F	RW		CF	
PRT4DM0	10	RW		50		ASD20CR0	90	RW	GDI_O_IN	D0	RW
PRT4DM1	11	RW		51		ASD20CR1	91	RW	GDI_E_IN	D1	RW
PRT4IC0	12	RW		52		ASD20CR2	92	RW	GDI_O_OU	D2	RW
PRT4IC1	13	RW		53		ASD20CR3	93	RW	GDI_E_OU	D3	RW
PRT5DM0	14	RW		54		ASC21CR0	94	RW		D4	
PRT5DM1	15	RW		55		ASC21CR1	95	RW		D5	
PRT5IC0	16	RW		56		ASC21CR2	96	RW		D6	
PRT5IC1	17	RW		57		ASC21CR3	97	RW		D7	
	18			58		ASD22CR0	98	RW		D8	
	19			59		ASD22CR1	99	RW		D9	
	1A			5A		ASD22CR2	9A	RW		DA	
	1B			5B		ASD22CR3	9B	RW		DB	
	1C			5C		ASC23CR0	9C	RW		DC	
	1D			5D		ASC23CR1	9D	RW	OSC_GO_EN	DD	RW
	1E			5E		ASC23CR2	9E	RW	OSC_CR4	DE	RW
	1F			5F		ASC23CR3	9F	RW	OSC_CR3	DF	RW
DBB00FN	20	RW	CLK_CR0	60	RW		A0		OSC_CR0	E0	RW
DBB00IN	21	RW	CLK_CR1	61	RW		A1		OSC_CR1	E1	RW
DBB00OU	22	RW	ABF_CR0	62	RW		A2		OSC_CR2	E2	RW
	23		AMD_CR0	63	RW		A3		VLT_CR	E3	RW
DBB01FN	24	RW		64			A4		VLT_CMP	E4	R
DBB01IN	25	RW		65			A5			E5	
DBB01OU	26	RW	AMD_CR1	66	RW		A6			E6	
	27		ALT_CR0	67	RW		A7			E7	
DCB02FN	28	RW	ALT_CR1	68	RW		A8		IMO_TR	E8	W
DCB02IN	29	RW	CLK_CR2	69	RW		A9		ILO_TR	E9	W
DCB02OU	2A	RW		6A			AA		BDG_TR	EA	RW
	2B			6B			AB		ECO_TR	EB	W
DCB03FN	2C	RW		6C			AC			EC	
DCB03IN	2D	RW		6D			AD			ED	
DCB03OU	2E	RW		6E			AE			EE	
	2F			6F			AF			EF	
DBB10FN	30	RW	ACB00CR3	70	RW	RD10RI	B0	RW		F0	
DBB10IN	31	RW	ACB00CR0	71	RW	RD10SYN	B1	RW		F1	
DBB10OU	32	RW	ACB00CR1	72	RW	RD10IS	B2	RW		F2	
	33		ACB00CR2	73	RW	RD10LT0	B3	RW		F3	
DBB11FN	34	RW	ACB01CR3	74	RW	RD10LT1	B4	RW		F4	
DBB11IN	35	RW	ACB01CR0	75	RW	RD10RO0	B5	RW		F5	
DBB11OU	36	RW	ACB01CR1	76	RW	RD10RO1	B6	RW		F6	
	37		ACB01CR2	77	RW		B7		CPU_F	F7	RL
DCB12FN	38	RW	ACB02CR3	78	RW	RD11RI	B8	RW		F8	
DCB12IN	39	RW	ACB02CR0	79	RW	RD11SYN	B9	RW		F9	
DCB12OU	3A	RW	ACB02CR1	7A	RW	RD11IS	BA	RW		FA	
	3B		ACB02CR2	7B	RW	RD11LT0	BB	RW		FB	
DCB13FN	3C	RW	ACB03CR3	7C	RW	RD11LT1	BC	RW		FC	
DCB13IN	3D	RW	ACB03CR0	7D	RW	RD11RO0	BD	RW		FD	
DCB13OU	3E	RW	ACB03CR1	7E	RW	RD11RO1	BE	RW	CPU_SCR1	FE	#
	3F		ACB03CR2	7F	RW		BF		CPU_SCR0	FF	#

Blank fields are Reserved and should not be accessed. # Access is bit specific.

# 3. Electrical Specifications



This chapter presents the DC and AC electrical specifications of the CY8C27x43 automotive PSoC device. For the most up to date electrical specifications, confirm that you have the most recent data sheet by going to the web at <http://www.cypress.com/psoc>.

Specifications are valid for  $-40^{\circ}\text{C} \leq T_A \leq 105^{\circ}\text{C}$  and  $T_J \leq 125^{\circ}\text{C}$ , except where noted.

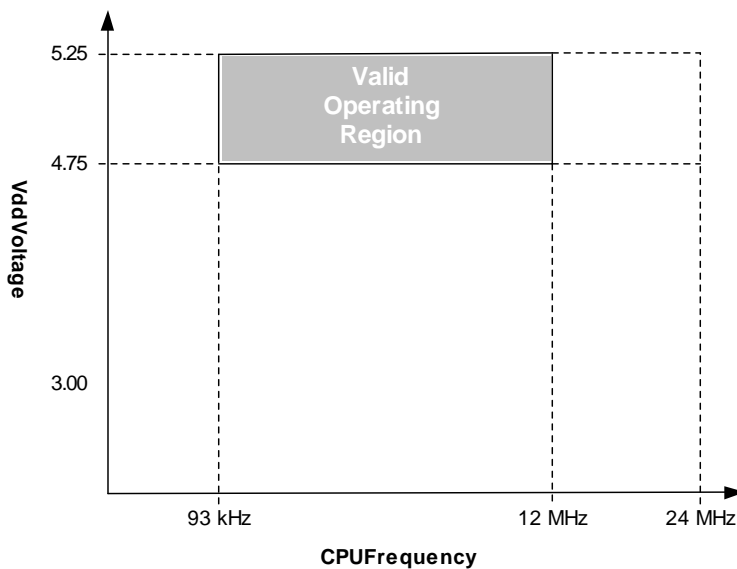

**Figure 3-1. Voltage versus CPU Frequency**

The following table lists the units of measure that are used in this chapter.

**Table 3-1: Units of Measure**

Symbol	Unit of Measure	Symbol	Unit of Measure
°C	degree Celsius	μW	microwatts
dB	decibels	mA	milli-ampere
fF	femto farad	ms	milli-second
Hz	hertz	mV	milli-volts
KB	1024 bytes	nA	nanoampere
Kbit	1024 bits	ns	nanosecond
kHz	kilohertz	nV	nanovolts
kΩ	kilohm	Ω	ohm
MHz	megahertz	pA	picoampere
MΩ	megaohm	pF	picofarad
μA	microampere	pp	peak-to-peak
μF	microfarad	ppm	parts per million
μH	microhenry	ps	picosecond
μs	microsecond	sps	samples per second
μV	microvolts	σ	sigma: one standard deviation
μVrms	microvolts root-mean-square	V	volts

## 3.1 Absolute Maximum Ratings

Table 3-2: Absolute Maximum Ratings

Symbol	Description	Min	Typ	Max	Units	Notes
T <sub>STG</sub>	Storage Temperature	-55	+25	+105	°C	Higher storage temperatures will reduce data retention time. Recommended storage temperature is +25°C ± 25°C. Storage temperatures above 65°C will degrade reliability. Maximum combined storage and operational time at +105°C is 7000 hours.
T <sub>A</sub>	Ambient Temperature with Power Applied	-40	–	+105	°C	
V <sub>dd</sub>	Supply Voltage on Vdd Relative to Vss	-0.5	–	+5.5	V	
V <sub>IO</sub>	DC Input Voltage	V <sub>ss</sub> - 0.5	–	V <sub>dd</sub> + 0.5	V	
V <sub>IOZ</sub>	DC Voltage Applied to Tri-state	V <sub>ss</sub> - 0.5	–	V <sub>dd</sub> + 0.5	V	
I <sub>MIO</sub>	Maximum Current into any Port Pin	-25	–	+25	mA	
I <sub>MAIO</sub>	Maximum Current into any Port Pin Configured as Analog Driver	-50	–	+50	mA	
ESD	Static Discharge Voltage	2000	–	–	V	Human Body Model ESD.
LU	Latch-up Current	–	–	200	mA	

## 3.2 Operating Temperature

Table 3-3: Operating Temperature

Symbol	Description	Min	Typ	Max	Units	Notes
T <sub>A</sub>	Ambient Temperature	-40	–	+105	°C	
T <sub>J</sub>	Junction Temperature	-40	–	+125	°C	The temperature rise from ambient to junction is package specific. See <a href="#">"Thermal Impedances per Package"</a> on page 32. The user must limit the power consumption to comply with this requirement.

## 3.3 DC Electrical Characteristics

### 3.3.1 DC Chip-Level Specifications

The following table lists guaranteed maximum and minimum specifications for the voltage and temperature ranges: 4.75V to 5.25V and  $-40^{\circ}\text{C} \leq T_A \leq 105^{\circ}\text{C}$ . Typical parameters apply to 5V at  $25^{\circ}\text{C}$  and are for design guidance only.

**Table 3-4: DC Chip-Level Specifications**

Symbol	Description	Min	Typ	Max	Units	Notes
V <sub>DD</sub>	Supply Voltage	4.75	–	5.25	V	
I <sub>DD</sub>	Supply Current	–	5	8	mA	Conditions are V <sub>DD</sub> = 5.25V, $-40^{\circ}\text{C} \leq T_A \leq 105^{\circ}\text{C}$ , CPU = 3 MHz, SYSCLK doubler disabled, VC1 = 1.5 MHz, VC2 = 93.75 kHz, VC3 = 93.75 kHz, analog power = off.
I <sub>SB</sub>	Sleep (Mode) Current with POR, LVD, Sleep Timer, and WDT. <sup>a</sup>	–	5	14	μA	Conditions are with internal slow speed oscillator, V <sub>DD</sub> = 5.25V, $-40^{\circ}\text{C} \leq T_A \leq 55^{\circ}\text{C}$ . Analog power = off.
I <sub>SBH</sub>	Sleep (Mode) Current with POR, LVD, Sleep Timer, and WDT. <sup>a</sup>	–	5	100	μA	Conditions are with internal slow speed oscillator, V <sub>DD</sub> = 5.25V, $55^{\circ}\text{C} < T_A \leq 105^{\circ}\text{C}$ . Analog power = off.
I <sub>SBXTL</sub>	Sleep (Mode) Current with POR, LVD, Sleep Timer, and WDT. <sup>a</sup>	–	7	16	μA	Conditions are with properly loaded, 1 μW max, 32.768 kHz crystal. V <sub>DD</sub> = 5.25V, $-40^{\circ}\text{C} \leq T_A \leq 55^{\circ}\text{C}$ . Analog power = off.
I <sub>SBXTLH</sub>	Sleep (Mode) Current with POR, LVD, Sleep Timer, and WDT. <sup>a</sup>	–	7	100	μA	Conditions are with properly loaded, 1 μW max, 32.768 kHz crystal. V <sub>DD</sub> = 5.25V, $55^{\circ}\text{C} < T_A \leq 105^{\circ}\text{C}$ . Analog power = off.
V <sub>REF</sub>	Reference Voltage (Bandgap)	1.25	1.3	1.35	V	Trimmed for appropriate V <sub>DD</sub> .

a. Standby current includes all functions (POR, LVD, WDT, Sleep Time) needed for reliable system operation. This should be compared with devices that have similar functions enabled.

### 3.3.2 DC General Purpose IO Specifications

The following table lists guaranteed maximum and minimum specifications for the voltage and temperature ranges: 4.75V to 5.25V and  $-40^{\circ}\text{C} \leq T_A \leq 105^{\circ}\text{C}$ . Typical parameters apply to 5V at  $25^{\circ}\text{C}$  and are for design guidance only.

**Table 3-5: DC GPIO Specifications**

Symbol	Description	Min	Typ	Max	Units	Notes
R <sub>PU</sub>	Pull up Resistor	4	5.6	8	kΩ	
R <sub>PD</sub>	Pull down Resistor	4	5.6	8	kΩ	
V <sub>OH</sub>	High Output Level	3.5	–	–	V	I <sub>OH</sub> = 10 mA, V <sub>DD</sub> = 4.75 to 5.25V (8 total loads, 4 on even port pins (for example, P0[2], P1[4]), 4 on odd port pins (for example, P0[3], P1[5])).
V <sub>OL</sub>	Low Output Level	–	–	0.75	V	I <sub>OL</sub> = 25 mA, V <sub>DD</sub> = 4.75 to 5.25V (8 total loads, 4 on even port pins (for example, P0[2], P1[4]), 4 on odd port pins (for example, P0[3], P1[5])).
V <sub>IL</sub>	Input Low Level	–	–	0.8	V	V <sub>DD</sub> = 4.75 to 5.25.
V <sub>IH</sub>	Input High Level	2.2	–	–	V	V <sub>DD</sub> = 4.75 to 5.25.
V <sub>H</sub>	Input Hysteresis	–	110	–	mV	
I <sub>IL</sub>	Input Leakage (Absolute Value)	–	1	–	nA	Gross tested to 1 μA.
C <sub>IN</sub>	Capacitive Load on Pins as Input	–	3.5	10	pF	Package and pin dependent. Temp = $25^{\circ}\text{C}$ .
C <sub>OUT</sub>	Capacitive Load on Pins as Output	–	3.5	10	pF	Package and pin dependent. Temp = $25^{\circ}\text{C}$ .

### 3.3.3 DC Operational Amplifier Specifications

The following tables list guaranteed maximum and minimum specifications for the voltage and temperature ranges: 4.75V to 5.25V and  $-40^{\circ}\text{C} \leq T_A \leq 105^{\circ}\text{C}$ . Typical parameters apply to 5V at  $25^{\circ}\text{C}$  and are for design guidance.

The Operational Amplifier is a component of both the Analog Continuous Time PSoC blocks and the Analog Switched Cap PSoC blocks. The guaranteed specifications are measured in the Analog Continuous Time PSoC block.

**Table 3-6: DC Operational Amplifier Specifications**

Symbol	Description	Min	Typ	Max	Units	Notes
$V_{\text{OSOA}}$	Input Offset Voltage (absolute value) Low Power	–	1.6	11	mV	
	Input Offset Voltage (absolute value) Mid Power	–	1.3	9	mV	
	Input Offset Voltage (absolute value) High Power	–	1.2	9	mV	
$\text{TCV}_{\text{OSOA}}$	Input Offset Voltage Drift	–	7.0	35.0	$\mu\text{V}/^{\circ}\text{C}$	
$I_{\text{EBOA}}$	Input Leakage Current (Port 0 Analog Pins)	–	10	200	pA	
$C_{\text{INOA}}$	Input Capacitance (Port 0 Analog Pins)	–	4.5	10	pF	Package and pin dependent. Temp = $25^{\circ}\text{C}$ .
$V_{\text{CMOA}}$	Common Mode Voltage Range	0.0	–	Vdd	V	The common-mode input voltage range is measured through an analog output buffer. The specification includes the limitations imposed by the characteristics of the analog output buffer.
	Common Mode Voltage Range (high power or high opamp bias)	0.5	–	Vdd - 0.5	V	
$G_{\text{OLOA}}$	Open Loop Gain	–	–	–	dB	Specification is applicable at high power. For all other bias modes (except high power, high opamp bias), minimum is 60 dB.
	Power=Low	–	80	–	–	
	Power=Medium	–	80	–	–	
	Power=High	–	80	–	–	
$V_{\text{OHIGHOA}}$	High Output Voltage Swing (worst case internal load)					
	Power=Low	Vdd - 0.2	–	–	V	
	Power=Medium	Vdd - 0.2	–	–	V	
$V_{\text{OLOA}}$	Low Output Voltage Swing (worst case internal load)					
	Power=Low	–	–	0.2	V	
	Power=Medium	–	–	0.2	V	
$I_{\text{SOA}}$	Supply Current (including associated AGND buffer)	–				
	Power=Low	–	150	200	$\mu\text{A}$	
	Power=Low, Opamp Bias=High	–	300	400	$\mu\text{A}$	
	Power=Medium	–	600	800	$\mu\text{A}$	
	Power=Medium, Opamp Bias=High	–	1200	1600	$\mu\text{A}$	
	Power=High	–	2400	3200	$\mu\text{A}$	
$\text{PSRR}_{\text{OA}}$	Supply Voltage Rejection Ratio	–	80	–	dB	$V_{\text{SS}} \leq V_{\text{IN}} \leq (V_{\text{DD}} - 2.25)$ or $(V_{\text{DD}} - 1.25\text{V}) \leq V_{\text{IN}} \leq V_{\text{DD}}$ .

### 3.3.4 DC Low Power Comparator Specifications

The following tables list guaranteed maximum and minimum specifications for the voltage and temperature ranges: 4.75V to 5.25V and  $-40^{\circ}\text{C} \leq T_A \leq 105^{\circ}\text{C}$ . Typical parameters apply to 5V at  $25^{\circ}\text{C}$  and are for design guidance only.

**Table 3-7: DC Low Power Comparator Specifications**

Symbol	Description	Min	Typ	Max	Units	Notes
$V_{\text{REFLPC}}$	Low power comparator (LPC) reference voltage range	0.2	–	Vdd - 1	V	
$I_{\text{SLPC}}$	LPC supply current	–	10	40	$\mu\text{A}$	
$V_{\text{OSLPC}}$	LPC voltage offset	–	2.5	30	mV	

### 3.3.5 DC Analog Output Buffer Specifications

The following tables list guaranteed maximum and minimum specifications for the voltage and temperature ranges: 4.75V to 5.25V and  $-40^{\circ}\text{C} \leq T_A \leq 105^{\circ}\text{C}$ . Typical parameters apply to 5V at  $25^{\circ}\text{C}$  and are for design guidance only.

**Table 3-8: DC Analog Output Buffer Specifications**

Symbol	Description	Min	Typ	Max	Units	Notes
$V_{OSOB}$	Input Offset Voltage (Absolute Value)	–	3	18	mV	
$TCV_{OSOB}$	Input Offset Voltage Drift	–	+6	–	$\mu\text{V}/^{\circ}\text{C}$	
$V_{CMOB}$	Common-Mode Input Voltage Range	.5	–	Vdd - 1.0	V	
$R_{OUTOB}$	Output Resistance	–	1	–	$\Omega$	
$V_{OHIGHOB}$	High Output Voltage Swing (Load = 32 ohms to Vdd/2)	.5 x Vdd + 1.3	–	–	V	
$V_{OLOWOB}$	Low Output Voltage Swing (Load = 32 ohms to Vdd/2)	–	–	.5 x Vdd - 1.3	V	
$I_{SOB}$	Supply Current Including Bias Cell (No Load)	–	–	–	–	–
	Power = Low	–	1.1	5.1	mA	
	Power = High	–	2.6	8.8	mA	
$PSRR_{OB}$	Supply Voltage Rejection Ratio	–	64	–	dB	

### 3.3.6 DC Analog Reference Specifications

The following tables list guaranteed maximum and minimum specifications for the voltage and temperature ranges: 4.75V to 5.25V and  $-40^{\circ}\text{C} \leq T_A \leq 105^{\circ}\text{C}$ . Typical parameters apply to 5V at  $25^{\circ}\text{C}$  and are for design guidance only.

The guaranteed specifications are measured through the Analog Continuous Time PSoC blocks. The power levels for AGND refer to the power of the Analog Continuous Time PSoC block. The power levels for RefHi and RefLo refer to the Analog Reference Control register. The limits stated for AGND include the offset error of the AGND buffer local to the Analog Continuous Time PSoC block.

**Note** Avoid using P2[4] for digital signaling when using an analog resource that depends on the Analog Reference. Some coupling of the digital signal may appear on the AGND.

**Table 3-9: DC Analog Reference Specifications**

Symbol	Description	Min	Typ	Max	Units
$V_{BG5}$	Bandgap Voltage Reference 5V	1.25	1.30	1.35	V
–	AGND = $V_{dd}/2^a$ CT Block Power = High	$V_{dd}/2 - 0.02$	$V_{dd}/2$	$V_{dd}/2 + 0.02$	V
–	AGND = $2 \times \text{BandGap}^a$ CT Block Power = High	2.4	2.60	2.8	V
–	AGND = P2[4] (P2[4] = $V_{dd}/2^a$ ) CT Block Power = High	P2[4] - 0.02	P2[4]	P2[4] + 0.02	V
–	AGND = BandGap <sup>a</sup> CT Block Power = High	1.23	1.3	1.37	V
–	AGND = $1.6 \times \text{BandGap}^a$ CT Block Power = High	1.98	2.08	2.14	V
–	AGND Column to Column Variation (AGND= $V_{dd}/2^a$ ) CT Block Power = High	- 0.035	0.000	0.035	V
–	RefHi = $V_{dd}/2 + \text{BandGap}$ Ref Control Power = High	$V_{dd}/2 + 1.15$	$V_{dd}/2 + 1.30$	$V_{dd}/2 + 1.45$	V
–	RefHi = $3 \times \text{BandGap}$ Ref Control Power = High	3.65	3.9	4.15	V
–	RefHi = $2 \times \text{BandGap} + \text{P2}[6]$ (P2[6] = 1.3V) Ref Control Power = High	P2[6] + 2.4	P2[6] + 2.6	P2[6] + 2.8	V
–	RefHi = P2[4] + BandGap (P2[4] = $V_{dd}/2$ ) Ref Control Power = High	P2[4] + 1.24	P2[4] + 1.30	P2[4] + 1.36	V
–	RefHi = P2[4] + P2[6] (P2[4] = $V_{dd}/2$ , P2[6] = 1.3V) Ref Control Power = High	P2[4] + P2[6] - 0.1	P2[4] + P2[6]	P2[4] + P2[6] + 0.1	V
–	RefHi = $2 \times \text{BandGap}$ Ref Control Power = High	2.4	2.60	2.8	V
–	RefHi = $3.2 \times \text{BandGap}$ Ref Control Power = High	3.9	4.16	4.42	V
–	RefLo = $V_{dd}/2 - \text{BandGap}$ Ref Control Power = High	$V_{dd}/2 - 1.45$	$V_{dd}/2 - 1.3$	$V_{dd}/2 - 1.15$	V
–	RefLo = BandGap Ref Control Power = High	1.15	1.30	1.45	V
–	RefLo = $2 \times \text{BandGap} - \text{P2}[6]$ (P2[6] = 1.3V) Ref Control Power = High	$2.4 - \text{P2}[6]$	$2.6 - \text{P2}[6]$	$2.8 + \text{P2}[6]$	V
–	RefLo = P2[4] - BandGap (P2[4] = $V_{dd}/2$ ) Ref Control Power = High	P2[4] - 1.45	P2[4] - 1.3	P2[4] - 1.15	V
–	RefLo = P2[4]-P2[6] (P2[4] = $V_{dd}/2$ , P2[6] = 1.3V) Ref Control Power = High	P2[4] - P2[6] - 0.1	P2[4] - P26	P2[4] - P2[6] + 0.1	V

a. AGND tolerance includes the offsets of the local buffer in the PSoC block. BG = Bandgap voltage is  $1.3V \pm 0.05V$ .

### 3.3.7 DC Analog PSoC Block Specifications

The following table lists guaranteed maximum and minimum specifications for the voltage and temperature ranges: 4.75V to 5.25V and  $-40^{\circ}\text{C} \leq T_A \leq 105^{\circ}\text{C}$ . Typical parameters apply to 5V at 25°C and are for design guidance only.

**Table 3-10: DC Analog PSoC Block Specifications**

Symbol	Description	Min	Typ	Max	Units	Notes
R <sub>CT</sub>	Resistor Unit Value (Continuous Time)	–	12.24	–	kΩ	
C <sub>SC</sub>	Capacitor Unit Value (Switched Capacitor)	–	80	–	fF	

### 3.3.8 DC POR and LVD Specifications

The following table lists guaranteed maximum and minimum specifications for the voltage and temperature ranges: 4.75V to 5.25V and  $-40^{\circ}\text{C} \leq T_A \leq 105^{\circ}\text{C}$ . Typical parameters apply to 5V at 25°C and are for design guidance only.

**Table 3-11: DC POR and LVD Specifications**

Symbol	Description	Min	Typ	Max	Units	Notes
V <sub>PPOR1R</sub> V <sub>PPOR2R</sub>	Vdd Value for PPOR Trip (positive ramp) PORLEV[1:0] = 01b PORLEV[1:0] = 10b	–	4.40 4.60	–	V V	
V <sub>PPOR1</sub> V <sub>PPOR2</sub>	Vdd Value for PPOR Trip (negative ramp) PORLEV[1:0] = 01b PORLEV[1:0] = 10b	–	4.40 4.60	–	V V	
V <sub>PH1</sub> V <sub>PH2</sub>	PPOR Hysteresis PORLEV[1:0] = 01b PORLEV[1:0] = 10b	– –	0 0	– –	mV mV	
V <sub>LVD6</sub> V <sub>LVD7</sub>	Vdd Value for LVD Trip VM[2:0] = 110b VM[2:0] = 111b	4.54 4.63	4.80 4.90	4.92 5.01	V V	

### 3.3.9 DC Programming Specifications

The following table lists guaranteed maximum and minimum specifications for the voltage and temperature ranges: 4.75V to 5.25V and  $-40^{\circ}\text{C} \leq T_A \leq 105^{\circ}\text{C}$ . Typical parameters apply to 5V at  $25^{\circ}\text{C}$  and are for design guidance only.

**Table 3-12: DC Programming Specifications**

Symbol	Description	Min	Typ	Max	Units	Notes
$I_{DDP}$	Supply Current During Programming or Verify	–	15	25	mA	
$V_{ILP}$	Input Low Voltage During Programming or Verify	–	–	0.8	V	
$V_{IH P}$	Input High Voltage During Programming or Verify	2.2	–	–	V	
$I_{ILP}$	Input Current when Applying $V_{ilp}$ to P1[0] or P1[1] During Programming or Verify	–	–	0.2	mA	Driving internal pull-down resistor.
$I_{IHP}$	Input Current when Applying $V_{ihp}$ to P1[0] or P1[1] During Programming or Verify	–	–	1.5	mA	Driving internal pull-down resistor.
$V_{OLV}$	Output Low Voltage During Programming or Verify	–	–	$V_{SS} + 0.75$	V	
$V_{OHV}$	Output High Voltage During Programming or Verify	3.5	–	$V_{DD}$	V	
Flash <sub>ENPB</sub>	Flash Endurance (per block) <sup>a</sup>	100	–	–	–	Erase/write cycles per block.
Flash <sub>ENT</sub>	Flash Endurance (total) <sup>a,b</sup>	25,600	–	–	–	Erase/write cycles.
Flash <sub>DR</sub>	Flash Data Retention <sup>c</sup>	15	–	–	Years	

- For the full temperature range, the user must employ a temperature sensor user module (FlashTemp) and feed the result to the temperature argument before writing. Refer to the Flash APIs Application Note AN2015 at <http://www.cypress.com> under Application Notes for more information.
- A maximum of 256 x 100 block endurance cycles is allowed.
- Flash data retention based on the use condition of  $\leq 7000$  hours at  $T_A \leq 105^{\circ}\text{C}$  and the remaining time at  $T_A \leq 65^{\circ}\text{C}$ .

### 3.4 AC Electrical Characteristics

#### 3.4.1 AC Chip-Level Specifications

The following table lists guaranteed maximum and minimum specifications for the voltage and temperature ranges: 4.75V to 5.25V and  $-40^{\circ}\text{C} \leq T_A \leq 105^{\circ}\text{C}$ . Typical parameters apply to 5V at 25°C and are for design guidance only.

**Table 3-13: AC Chip-Level Specifications**

Symbol	Description	Min	Typ	Max	Units	Notes
F <sub>IMO24</sub>	Internal Main Oscillator Frequency for 24 MHz	22.95	24	24.96	MHz	Trimmed. Utilizing factory trim values.
F <sub>CPU1</sub>	CPU Frequency (5V Nominal)	0.90	12	12.48	MHz	
F <sub>48M</sub>	Digital PSoC Block Frequency	–	–	–	MHz	Not allowed.
F <sub>24M</sub>	Digital PSoC Block Frequency	0	24	24.96 <sup>a</sup>	MHz	
F <sub>32K1</sub>	Internal Low Speed Oscillator Frequency	15	32	64	kHz	
F <sub>32K2</sub>	External Crystal Oscillator	–	32.768	–	kHz	Accuracy is capacitor and crystal dependent.
F <sub>PLL</sub>	PLL Frequency	–	23.986	–	MHz	Is a multiple (x732) of crystal frequency.
Jitter24M2	24 MHz Period Jitter (PLL)	–	–	800	ps	
T <sub>PLLSLEW</sub>	PLL Lock Time	0.5	–	10	ms	
T <sub>PLLSLEWS-LOW</sub>	PLL Lock Time for Low Gain Setting	0.5	–	50	ms	
T <sub>OS</sub>	External Crystal Oscillator Startup to 1%	–	1700	2620	ms	
T <sub>OSACC</sub>	External Crystal Oscillator Startup to 200 ppm	–	2800	3800	ms	
Jitter32k	32 kHz Period Jitter	–	100	–	ns	
T <sub>XRST</sub>	External Reset Pulse Width	10	–	–	μs	
DC24M	24 MHz Duty Cycle	40	50	60	%	
Step24M	24 MHz Trim Step Size	–	50	–	kHz	
Jitter24M1P	24 MHz Period Jitter (IMO) Peak-to-Peak	–	300	–	ps	
Jitter24M1R	24 MHz Period Jitter (IMO) Root Mean Squared	–	–	600	ps	
F <sub>MAX</sub>	Maximum frequency of signal on row input or row output.	–	–	12.48	MHz	
T <sub>RAMP</sub>	Supply Ramp Time	0	–	–	μs	

a. See the individual user module data sheets for information on maximum frequencies for user modules.

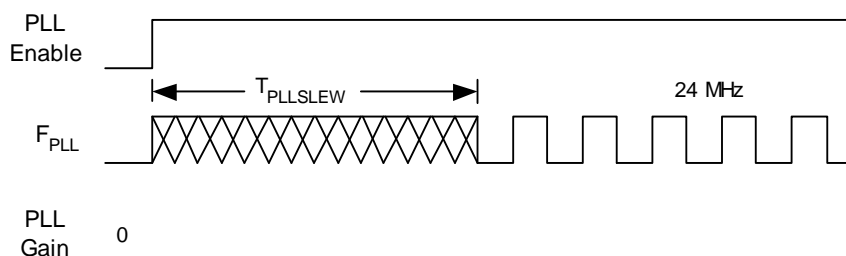

**Figure 3-2. PLL Lock Timing Diagram**

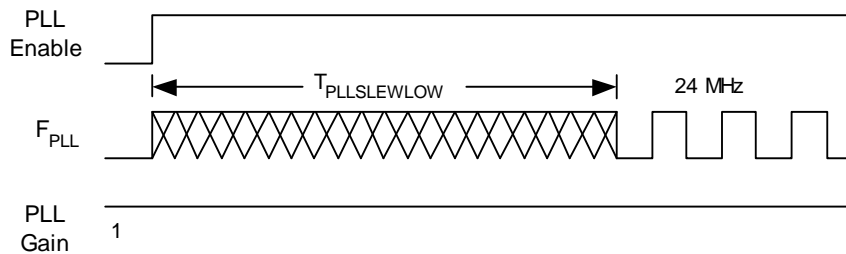

Figure 3-3. PLL Lock for Low Gain Setting Timing Diagram

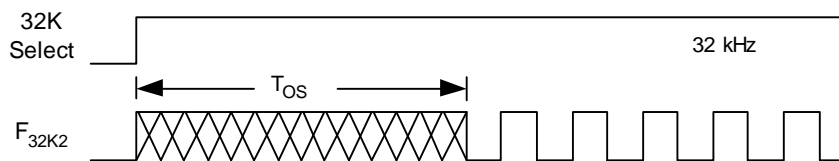

Figure 3-4. External Crystal Oscillator Startup Timing Diagram



Figure 3-5. 24 MHz Period Jitter (IMO) Timing Diagram

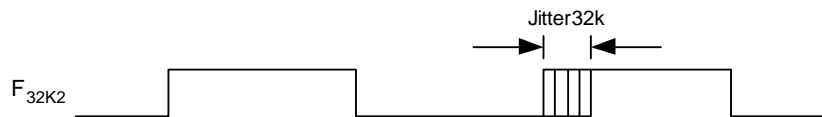

Figure 3-6. 32 kHz Period Jitter (ECO) Timing Diagram

### 3.4.2 AC General Purpose IO Specifications

The following table lists guaranteed maximum and minimum specifications for the voltage and temperature ranges: 4.75V to 5.25V and  $-40^{\circ}\text{C} \leq T_A \leq 105^{\circ}\text{C}$ . Typical parameters apply to 5V at  $25^{\circ}\text{C}$  and are for design guidance only.

**Table 3-14: AC GPIO Specifications**

Symbol	Description	Min	Typ	Max	Units	Notes
$F_{GPIO}$	GPIO Operating Frequency	0	–	12.48	MHz	Normal Strong Mode
$T_{RiseF}$	Rise Time, Normal Strong Mode, Clload = 50 pF	3	–	22	ns	Vdd = 4.75 to 5.25V, 10% - 90%
$T_{FallF}$	Fall Time, Normal Strong Mode, Clload = 50 pF	2	–	22	ns	Vdd = 4.75 to 5.25V, 10% - 90%
$T_{RiseS}$	Rise Time, Slow Strong Mode, Clload = 50 pF	9	27	–	ns	Vdd = 4.75 to 5.25V, 10% - 90%
$T_{FallS}$	Fall Time, Slow Strong Mode, Clload = 50 pF	9	22	–	ns	Vdd = 4.75 to 5.25V, 10% - 90%

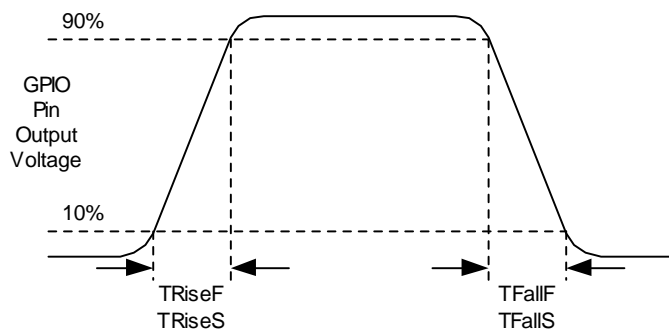

**Figure 3-7. GPIO Timing Diagram**

### 3.4.3 AC Operational Amplifier Specifications

The following tables list guaranteed maximum and minimum specifications for the voltage and temperature ranges: 4.75V to 5.25V and  $-40^{\circ}\text{C} \leq T_A \leq 105^{\circ}\text{C}$ . Typical parameters apply to 5V at  $25^{\circ}\text{C}$  and are for design guidance only.

Settling times, slew rates, and gain bandwidth are based on the Analog Continuous Time PSoC block.

**Table 3-15: AC Operational Amplifier Specifications**

Symbol	Description	Min	Typ	Max	Units	Notes
SR <sub>ROA</sub>	Rising Slew Rate (20% to 80%)(10 pF load, Unity Gain)					
	Power = Low	0.15	–		V/ $\mu\text{s}$	
	Power = Low, Opamp Bias = High	0.15	–		V/ $\mu\text{s}$	
	Power = Medium	0.15	–		V/ $\mu\text{s}$	
	Power = Medium, Opamp Bias = High	1.7	–		V/ $\mu\text{s}$	
	Power = High	1.7	–		V/ $\mu\text{s}$	
SR <sub>FOA</sub>	Falling Slew Rate (20% to 80%)(10 pF load, Unity Gain)					
	Power = Low	0.01	–		V/ $\mu\text{s}$	
	Power = Low, Opamp Bias = High	0.01	–		V/ $\mu\text{s}$	
	Power = Medium	0.01	–		V/ $\mu\text{s}$	
	Power = Medium, Opamp Bias = High	0.5	–		V/ $\mu\text{s}$	
	Power = High	0.5	–		V/ $\mu\text{s}$	
BW <sub>OA</sub>	Gain Bandwidth Product					
	Power = Low	0.75	–		MHz	
	Power = Low, Opamp Bias = High	0.75	–		MHz	
	Power = Medium	0.75	–		MHz	
	Power = Medium, Opamp Bias = High	3.1	–		MHz	
	Power = High	3.1	–		MHz	
	Power = High, Opamp Bias = High	5.4	–		MHz	

When bypassed by a capacitor on P2[4], the noise of the analog ground signal distributed to each block is reduced by a factor of up to 5 (14 dB). This is at frequencies above the corner frequency defined by the on-chip 8.1k resistance and the external capacitor.

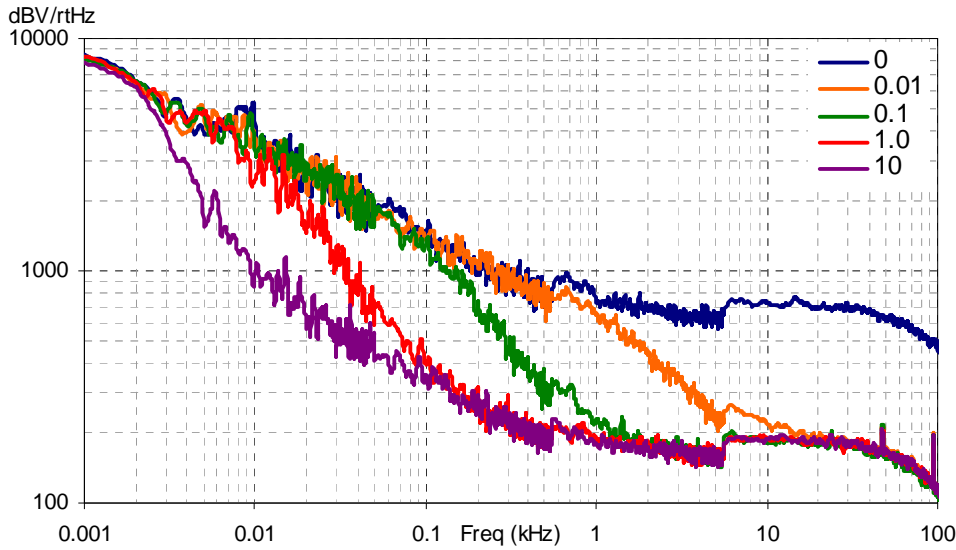

Figure 3-8. Typical AGND Noise with P2[4] Bypass

At low frequencies, the opamp noise is proportional to  $1/f$ , power independent, and determined by device geometry. At high frequencies, increased power level reduces the noise spectrum level.

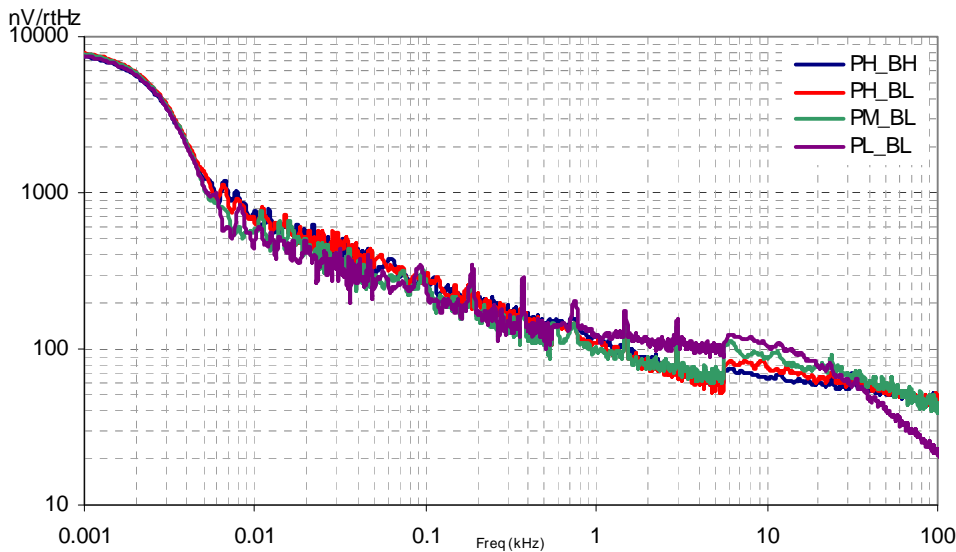

Figure 3-9. Typical Opamp Noise

### 3.4.4 AC Low Power Comparator Specifications

The following tables list guaranteed maximum and minimum specifications for the voltage and temperature ranges: 4.75V to 5.25V and  $-40^{\circ}\text{C} \leq T_A \leq 105^{\circ}\text{C}$ . Typical parameters apply to 5V at  $25^{\circ}\text{C}$  and are for design guidance only.

**Table 3-16. AC Low Power Comparator Specifications**

Symbol	Description	Min	Typ	Max	Units	Notes
$T_{RLPC}$	LPC response time	–	–	50	$\mu\text{s}$	$\geq 50$ mV overdrive comparator reference set within $V_{REFLPC}$ .

### 3.4.5 AC Digital Block Specifications

The following table lists guaranteed maximum and minimum specifications for the voltage and temperature ranges: 4.75V to 5.25V and  $-40^{\circ}\text{C} \leq T_A \leq 105^{\circ}\text{C}$ . Typical parameters apply to 5V at  $25^{\circ}\text{C}$  and are for design guidance only.

**Table 3-17: AC Digital Block Specifications**

Function	Description	Min	Typ	Max	Units	Notes
All Functions	Maximum Block Clocking Frequency (> 4.75V)			24.96		4.75V < Vdd < 5.25V.
Timer	Capture Pulse Width	50 <sup>a</sup>	–	–	ns	
	Maximum Frequency, No Capture	–	–	24.96	MHz	4.75V < Vdd < 5.25V.
	Maximum Frequency, With Capture	–	–	24.96	MHz	
Counter	Enable Pulse Width	50 <sup>a</sup>	–	–	ns	
	Maximum Frequency, No Enable Input	–	–	24.96	MHz	4.75V < Vdd < 5.25V.
	Maximum Frequency, Enable Input	–	–	24.96	MHz	
Dead Band	Kill Pulse Width:					
	Asynchronous Restart Mode	20	–	–	ns	
	Synchronous Restart Mode	50 <sup>a</sup>	–	–	ns	
	Disable Mode	50 <sup>a</sup>	–	–	ns	
	Maximum Frequency	–	–	24.96	MHz	4.75V < Vdd < 5.25V.
CRCPRS (PRS Mode)	Maximum Input Clock Frequency	–	–	24.96	MHz	4.75V < Vdd < 5.25V.
CRCPRS (CRC Mode)	Maximum Input Clock Frequency	–	–	24.96	MHz	
SPIM	Maximum Input Clock Frequency	–	–	4	MHz	Maximum data rate at 4.1 MHz due to 2 x over clocking.
SPIS	Maximum Input Clock Frequency	–	–	2	MHz	
	Width of SS_ Negated Between Transmissions	50 <sup>a</sup>	–	–	ns	
Transmitter	Maximum Input Clock Frequency	–	–	8	MHz	Maximum data rate at 3.08 MHz due to 8 x over clocking.
Receiver	Maximum Input Clock Frequency	–	16	24.96	MHz	Maximum data rate at 3.08 MHz due to 8 x over clocking.

a. 50 ns minimum input pulse width is based on the input synchronizers running at 24 MHz (42 ns nominal period).

### 3.4.6 AC Analog Output Buffer Specifications

The following tables list guaranteed maximum and minimum specifications for the voltage and temperature ranges: 4.75V to 5.25V and  $-40^{\circ}\text{C} \leq T_A \leq 105^{\circ}\text{C}$ . Typical parameters apply to 5V at  $25^{\circ}\text{C}$  and are for design guidance only.

**Table 3-18: AC Analog Output Buffer Specifications**

Symbol	Description	Min	Typ	Max	Units	Notes
T <sub>ROB</sub>	Rising Settling Time to 0.1%, 1V Step, 100pF Load					
	Power = Low	–	–	3	μs	
	Power = High	–	–	3	μs	
T <sub>SOB</sub>	Falling Settling Time to 0.1%, 1V Step, 100pF Load					
	Power = Low	–	–	3	μs	
	Power = High	–	–	3	μs	
SR <sub>ROB</sub>	Rising Slew Rate (20% to 80%), 1V Step, 100pF Load					
	Power = Low	0.6	–	–	V/μs	
	Power = High	0.6	–	–	V/μs	
SR <sub>FOB</sub>	Falling Slew Rate (80% to 20%), 1V Step, 100pF Load					
	Power = Low	0.6	–	–	V/μs	
	Power = High	0.6	–	–	V/μs	
BW <sub>OB</sub>	Small Signal Bandwidth, 20mV <sub>pp</sub> , 3dB BW, 100pF Load					
	Power = Low	0.8	–	–	MHz	
	Power = High	0.8	–	–	MHz	
BW <sub>OB</sub>	Large Signal Bandwidth, 1V <sub>pp</sub> , 3dB BW, 100pF Load					
	Power = Low	300	–	–	kHz	
	Power = High	300	–	–	kHz	

### 3.4.7 AC External Clock Specifications

The following tables list guaranteed maximum and minimum specifications for the voltage and temperature ranges: 4.75V to 5.25V and  $-40^{\circ}\text{C} \leq T_A \leq 105^{\circ}\text{C}$ . Typical parameters apply to 5V at  $25^{\circ}\text{C}$  and are for design guidance only.

**Table 3-19: AC External Clock Specifications**

Symbol	Description	Min	Typ	Max	Units	Notes
F <sub>OSCEXT</sub>	Frequency	0	–	24.24	MHz	
–	High Period	20.6	–	–	ns	
–	Low Period	20.6	–	–	ns	
–	Power Up IMO to Switch	150	–	–	μs	

### 3.4.8 AC Programming Specifications

The following table lists guaranteed maximum and minimum specifications for the voltage and temperature ranges: 4.75V to 5.25V and  $-40^{\circ}\text{C} \leq T_A \leq 105^{\circ}\text{C}$ . Typical parameters apply to 5V at  $25^{\circ}\text{C}$  and are for design guidance only.

**Table 3-20: AC Programming Specifications**

Symbol	Description	Min	Typ	Max	Units	Notes
$T_{RSCLK}$	Rise Time of SCLK	1	–	20	ns	
$T_{FSCLK}$	Fall Time of SCLK	1	–	20	ns	
$T_{SSCLK}$	Data Set up Time to Falling Edge of SCLK	40	–	–	ns	
$T_{HSCLK}$	Data Hold Time from Falling Edge of SCLK	40	–	–	ns	
$F_{SCLK}$	Frequency of SCLK	0	–	8	MHz	
$T_{ERASEB}$	Flash Erase Time (Block)	–	15	–	ms	
$T_{WRITE}$	Flash Block Write Time	–	30	–	ms	
$T_{DSCLK}$	Data Out Delay from Falling Edge of SCLK	–	–	45	ns	

### 3.4.9 AC I<sup>2</sup>C Specifications

The following table lists guaranteed maximum and minimum specifications for the voltage and temperature ranges: 4.75V to 5.25V and  $-40^{\circ}\text{C} \leq T_A \leq 105^{\circ}\text{C}$ . Typical parameters apply to 5V at  $25^{\circ}\text{C}$  and are for design guidance only.

**Table 3-21: AC Characteristics of the I<sup>2</sup>C SDA and SCL Pins**

Symbol	Description	Standard Mode		Fast Mode		Units	Notes
		Min	Max	Min	Max		
$F_{SCL2C}$	SCL Clock Frequency	0	100	0	400	kHz	
$T_{HDSTA12C}$	Hold Time (repeated) START Condition. After this period, the first clock pulse is generated.	4.0	–	0.6	–	$\mu\text{s}$	
$T_{LOWI2C}$	LOW Period of the SCL Clock	4.7	–	1.3	–	$\mu\text{s}$	
$T_{HIGHI2C}$	HIGH Period of the SCL Clock	4.0	–	0.6	–	$\mu\text{s}$	
$T_{SUSTA12C}$	Set-up Time for a Repeated START Condition	4.7	–	0.6	–	$\mu\text{s}$	
$T_{HDDAT12C}$	Data Hold Time	0	–	0	–	$\mu\text{s}$	
$T_{SUDAT12C}$	Data Set-up Time	250	–	100 <sup>a</sup>	–	ns	
$T_{SUSTOI2C}$	Set-up Time for STOP Condition	4.0	–	0.6	–	$\mu\text{s}$	
$T_{BUFI2C}$	Bus Free Time Between a STOP and START Condition	4.7	–	1.3	–	$\mu\text{s}$	
$T_{SPI2C}$	Pulse Width of spikes are suppressed by the input filter.	–	–	0	50	ns	

a. A Fast-Mode I2C-bus device can be used in a Standard-Mode I2C-bus system, but the requirement  $t_{SU,DAT} \geq 250$  ns must then be met. This will automatically be the case if the device does not stretch the LOW period of the SCL signal. If such device does stretch the LOW period of the SCL signal, it must output the next data bit to the SDA line  $t_{rmax} + t_{SU,DAT} = 1000 + 250 = 1250$  ns (according to the Standard-Mode I2C-bus specification) before the SCL line is released.

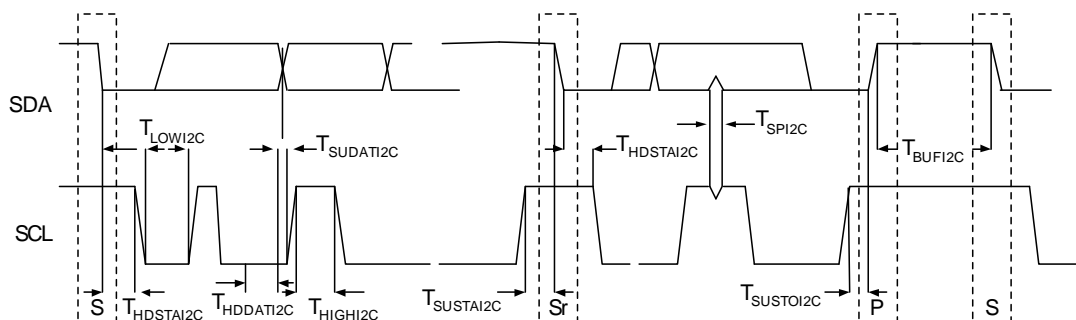

**Figure 3-10. Definition for Timing for Fast/Standard Mode on the I<sup>2</sup>C Bus**

# 4. Packaging Information



This chapter illustrates the packaging specifications for the CY8C27x43 automotive PSoC device, along with the thermal impedances for each package and the typical package capacitance on crystal pins.

**Important Note** Emulation tools may require a larger area on the target PCB than the chip's footprint. For a detailed description of the emulation tools' dimensions, refer to the document titled *PSoC Emulator Pod Dimensions* at <http://www.cypress.com/design/MR10161>.

## 4.1 Packaging Dimensions

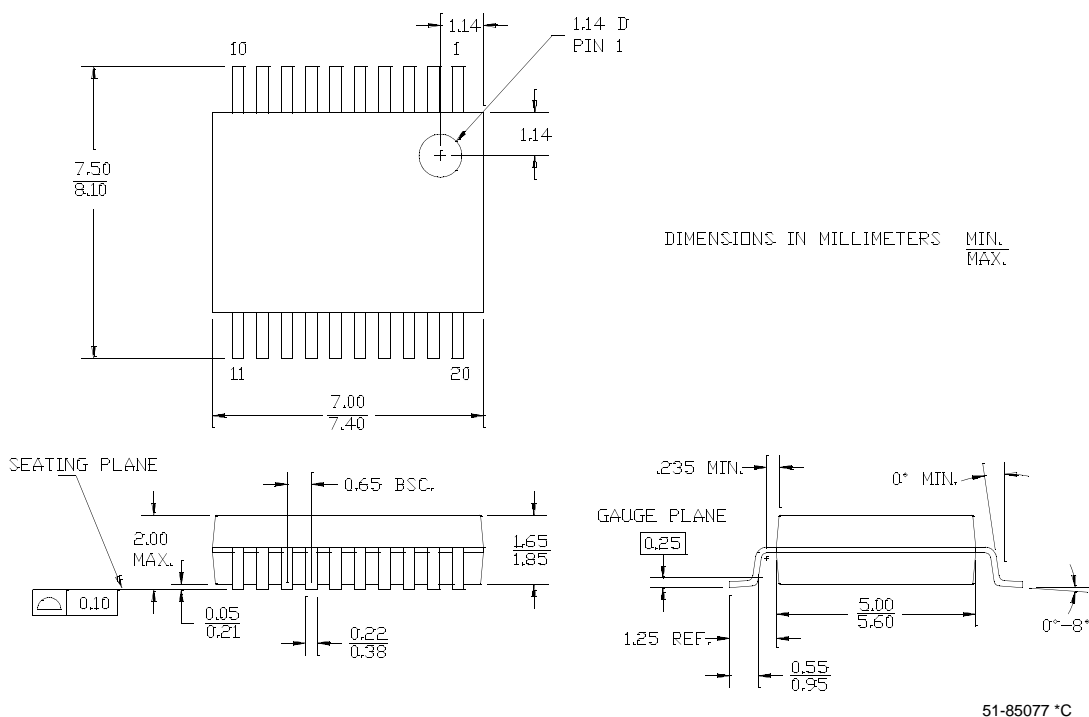

Figure 4-1. 20-Lead (210-Mil) SSOP

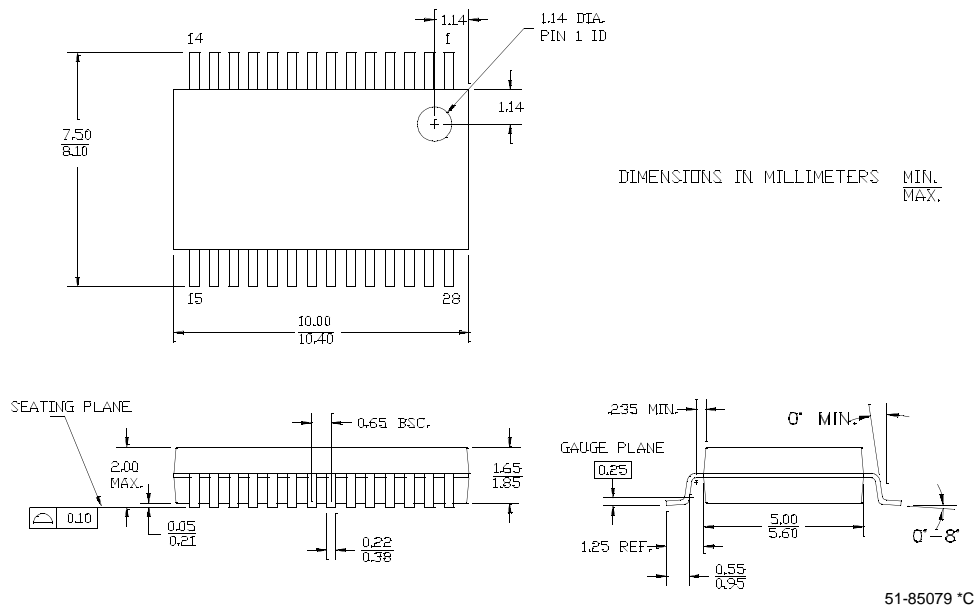

Figure 4-2. 28-Lead (210-Mil) SSOP

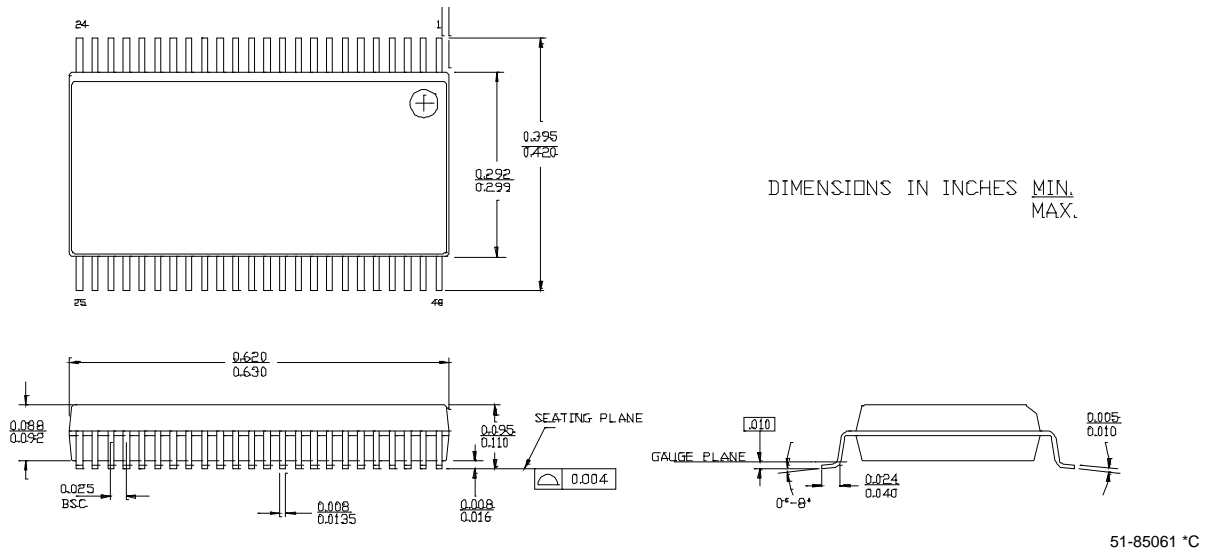

Figure 4-3. 48-Lead (300-Mil) SSOP

## 4.2 Thermal Impedances

Table 4-1. Thermal Impedances per Package

Package	Typical $\theta_{JA}$ *
20 SSOP	95 °C/W
28 SSOP	95 °C/W
48 SSOP	69 °C/W

$$* T_J = T_A + \text{POWER} \times \theta_{JA}$$

## 4.3 Capacitance on Crystal Pins

Table 4-2: Typical Package Capacitance on Crystal Pins

Package	Package Capacitance
20 SSOP	2.6 pF
28 SSOP	2.8 pF
48 SSOP	3.3 pF

## 4.4 Solder Reflow Peak Temperature

Following is the minimum solder reflow peak temperature to achieve good solderability.

Table 4-3. Solder Reflow Peak Temperature

Package	Minimum Peak Temperature*	Maximum Peak Temperature
20 SSOP	240°C	260°C
28 SSOP	240°C	260°C
48 SSOP	240°C	260°C

\*Higher temperatures may be required based on the solder melting point. Typical temperatures for solder are  $220 \pm 5^\circ\text{C}$  with Sn-Pb or  $245 \pm 5^\circ\text{C}$  with Sn-Ag-Cu paste. Refer to the solder manufacturer specifications.

# 5. Ordering Information



The following table lists the CY8C27x43 automotive PSoC device's key package features and ordering codes.

**Table 5-1. CY8C27x43 Automotive PSoC Key Features and Ordering Information**

Package	Ordering Code	Flash (Bytes)	RAM (Bytes)	Switch Mode Pump	Temperature Range	Digital Blocks	Analog Blocks	Digital IO Pins	Analog Inputs	Analog Outputs	XRES Pin
20 Pin (210 Mil) SSOP	CY8C27243-12PVXE	16K	256	No	-40C to +105C	8	12	16	8	4	Yes
20 Pin (210 Mil) SSOP (Tape and Reel)	CY8C27243-12PVXET	16K	256	No	-40C to +105C	8	12	16	8	4	Yes
28 Pin (210 Mil) SSOP	CY8C27443-12PVXE	16K	256	No	-40C to +105C	8	12	24	12	4	Yes
28 Pin (210 Mil) SSOP (Tape and Reel)	CY8C27443-12PVXET	16K	256	No	-40C to +105C	8	12	24	12	4	Yes
48 Pin (300 Mil) SSOP	CY8C27643-12PVXE	16K	256	No	-40C to +105C	8	12	44	12	4	Yes
48 Pin (300 Mil) SSOP (Tape and Reel)	CY8C27643-12PVXET	16K	256	No	-40C to +105C	8	12	44	12	4	Yes

**Note** For Die sales information, contact a local Cypress sales office or Field Applications Engineer (FAE).

## 5.1 Ordering Code Definitions

CY 8 C 27 xxx-SPxx

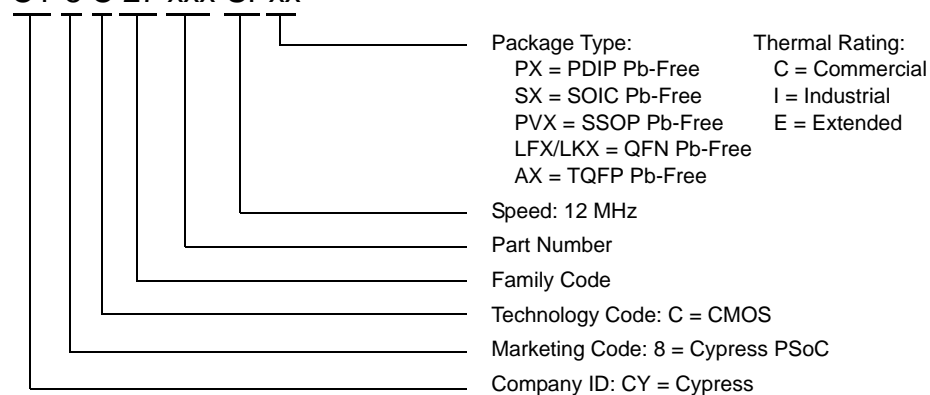



## Looking for pricing, stock, or lifecycle information?

Click below to explore more details on WIN SOURCE:

 [View CY8C27243-12PVXE on WIN SOURCE](#)

 [Infineon Technologies](#) Information

## Optimize Your Supply Chain with WIN SOURCE Solutions

-  Global Sourcing Solution
-  Obsolete Management
-  Cost Control Management
-  Shortage Management
-  Alternative Solution
-  Excess Inventory Management