



**THE DATASHEET OF  
SF2252E**



- **Low-loss RF SAW Filter**
- **3.0 x 3.0 x 1.4 mm Surface-mount Case**
- **No Matching Required for 50 Ω Operation**
- **Complies with Directive 2002/95/EC (RoHS)**
- **Moisture Sensitivity Level: 1**

**Absolute Maximum Ratings**

Rating	Value	Units
Incident Power in Passband	+10	dBm
DC Voltage on any Non-ground Terminal	3	VDC
Operating Temperature Range	-55 to +85	°C
Storage Temperature Range in Tape and Reel	-40 to +85	°C
Maximum Soldering Profile, 5 cycles/ 10 seconds maximum	265	°C

**SF2252E**

**1590 MHz  
SAW Filter**

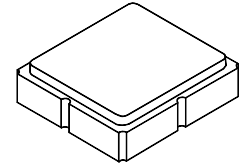

**SM3030-6**

**Electrical Characteristics**

Characteristic	Sym	Notes	Min	Typ	Max	Units
Center Frequency	$f_C$			1590		MHz
Minimum Insertion Loss	IL			2.3	4.0	dB
Amplitude Ripple				1.0	1.8	dB <sub>P-P</sub>
1.2 dB Bandwidth	BW <sub>1.2</sub>		55	59	65	MHz
20 dB Bandwidth	BW <sub>20</sub>			97	125	MHz
Ultimate Rejection				50		dB
Terminating Source impedance	Z <sub>L</sub>			50		Ω
Terminating Load impedance	Z <sub>L</sub>			50		Ω
Single Ended Input / Output Impedance match	No matching network required for operation at 50 ohms					
Case Style	SM3030-6					
Lid Symbolization: Y = Year, WW = Week, Y = Year)	993, <u>YWWS</u>					

 **CAUTION: Electrostatic Sensitive Device. Observe precautions for handling.**

**NOTES:**

1. The design, manufacturing process, and specifications of this device are subject to change.
2. US or International patents may apply.
3. RoHS compliant from the first date of manufacture.

# Matching Circuit

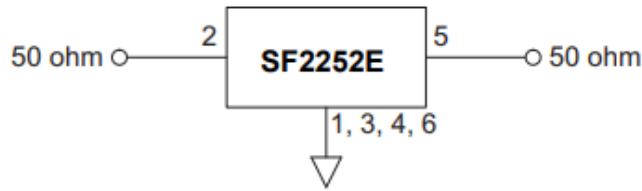

## Frequency Response Plots

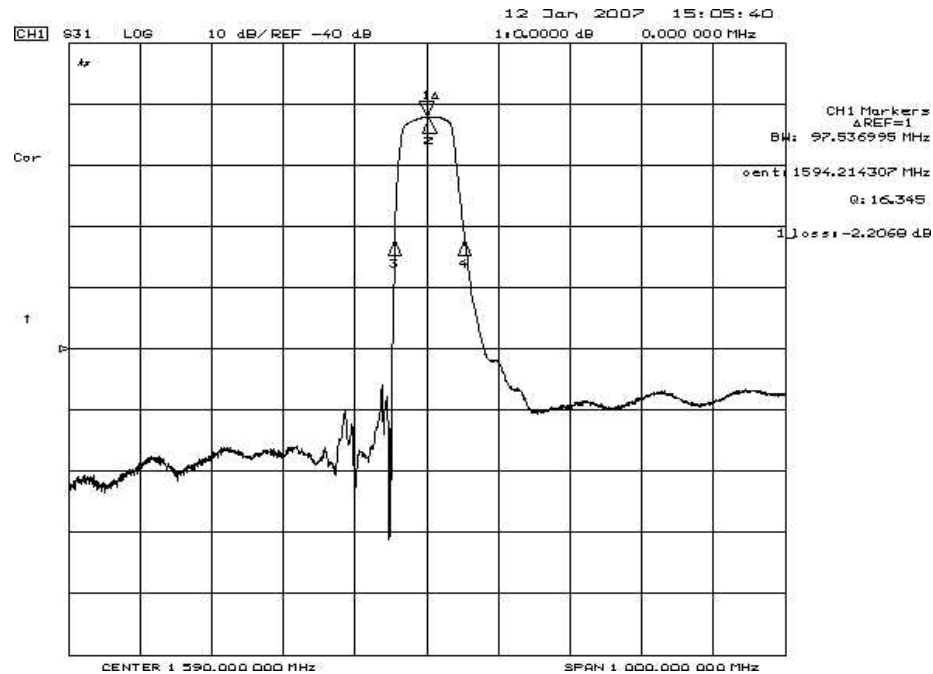
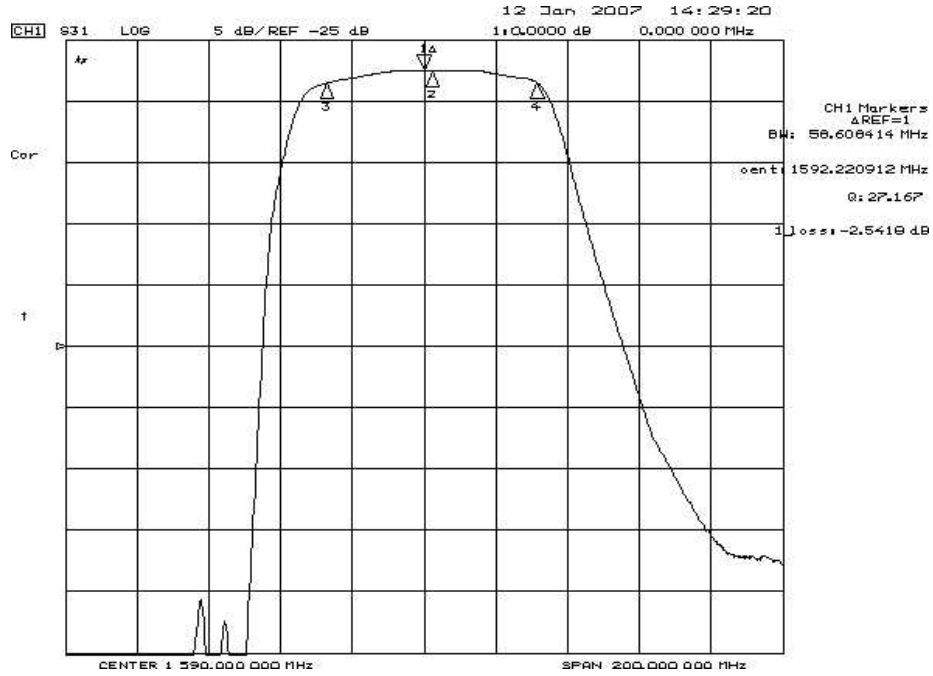

# VSWR Plots

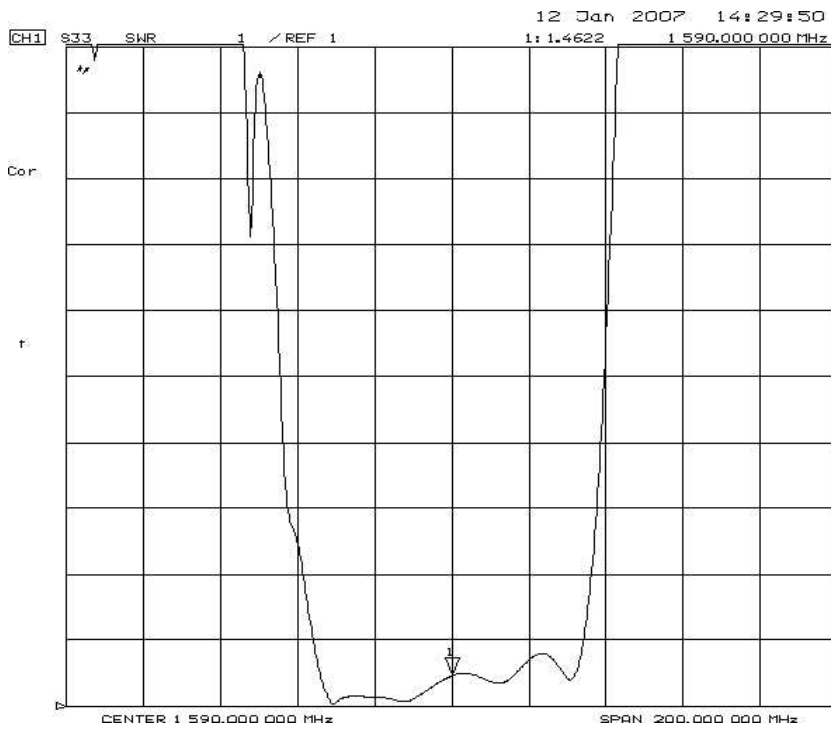
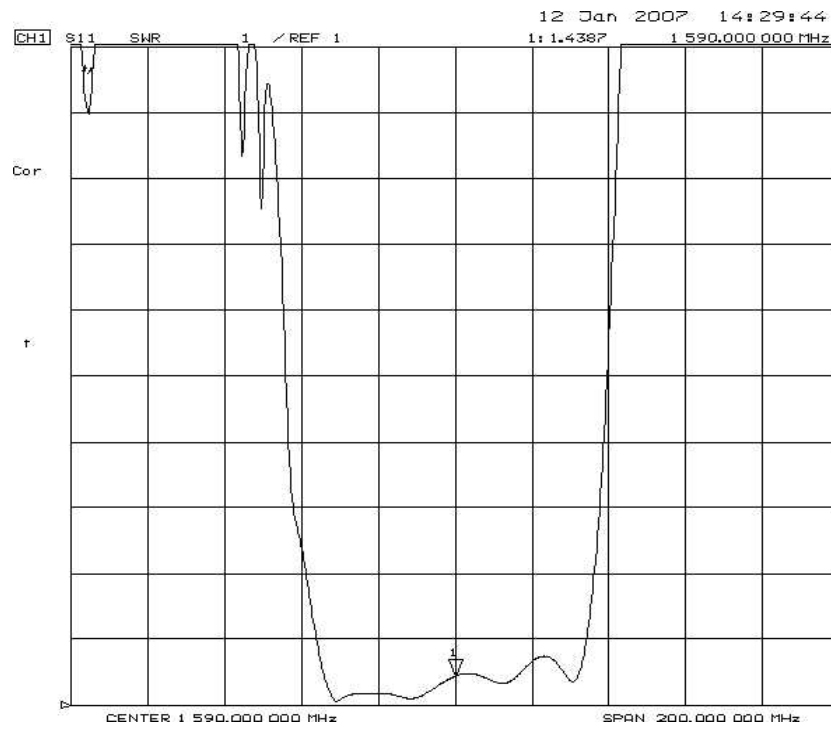

## 6-Terminal Ceramic Surface-Mount Case 3.0 X 3.0 mm Nominal Footprint

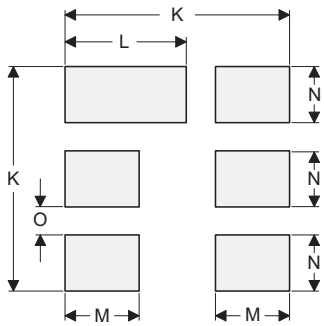
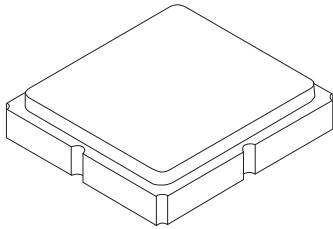

**PCB Footprint Top View**

### Case and PCB Footprint Dimensions

Dimension	mm			Inches		
	Min	Nom	Max	Min	Nom	Max
<b>A</b>	2.87	3.00	3.13	0.113	0.118	0.123
<b>B</b>	2.87	3.00	3.13	0.113	0.118	0.123
<b>C</b>	1.12	1.25	1.38	0.044	0.049	0.054
<b>D</b>	0.77	0.90	1.03	0.030	0.035	0.040
<b>E</b>	2.67	2.80	2.93	0.105	0.110	0.115
<b>F</b>	1.47	1.60	1.73	0.058	0.063	0.068
<b>G</b>	0.72	0.85	0.98	0.028	0.033	0.038
<b>H</b>	1.37	1.50	1.63	0.054	0.059	0.064
<b>I</b>	0.47	0.60	0.73	0.019	0.024	0.029
<b>J</b>	1.17	1.30	1.43	0.046	0.051	0.056
<b>K</b>		3.20			0.126	
<b>L</b>		1.70			0.067	
<b>M</b>		1.05			0.041	
<b>N</b>		0.81			0.032	
<b>O</b>		0.38			0.015	

### Case Materials

Materials	
Solder Pad Plating	0.3 to 1.0 $\mu\text{m}$ Gold over 1.27 to 8.89 $\mu\text{m}$ Nickel
Lid Plating	2.0 to 3.0 $\mu\text{m}$ Nickel
Body	$\text{Al}_2\text{O}_3$ Ceramic

### TOP VIEW

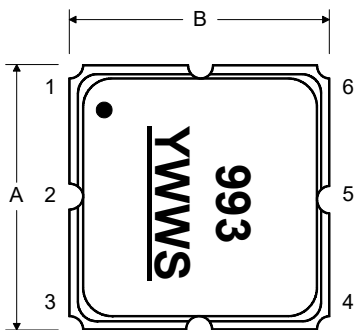

### BOTTOM VIEW

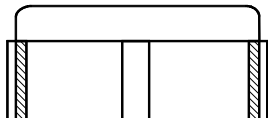
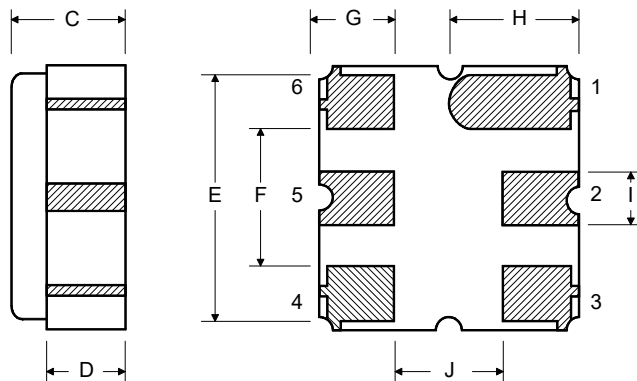



## Recommended Reflow Profile

1. Preheating shall be fixed at 150~180°C for 60~90 seconds.
2. Ascending time to preheating temperature 150°C shall be 30 seconds min.
3. Heating shall be fixed at 220°C for 50~80 seconds and at 260°C +0/-5°C peak (10 seconds).
4. Time: 5 times maximum.

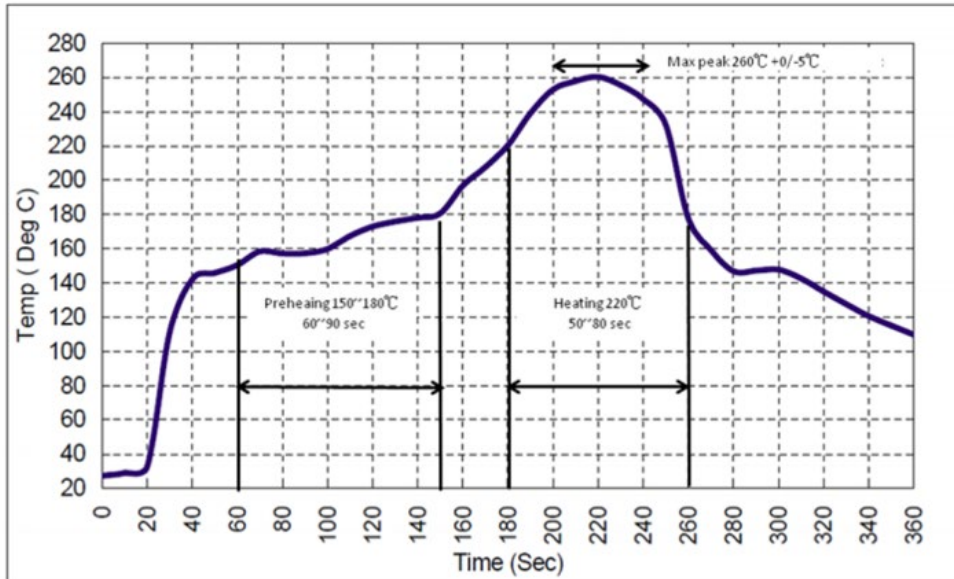

## Looking for pricing, stock, or lifecycle information?

Click below to explore more details on WIN SOURCE:

 [View SF2252E on WIN SOURCE](#)

 [RF Monolithics, Inc Information](#)

## Optimize Your Supply Chain with WIN SOURCE Solutions

-  Global Sourcing Solution
-  Obsolete Management
-  Cost Control Management
-  Shortage Management
-  Alternative Solution
-  Excess Inventory Management