



**THE DATASHEET OF  
AP8803WTG-7**



## Description

The AP8803 is a step-down DC/DC converter designed to drive LEDs with a constant current. The device can drive up to 7 LEDs, depending on the forward voltage of the LEDs, in series from a voltage source of 8V to 30V. Series connection of the LEDs provides identical LED currents resulting in uniform brightness and eliminating the need for ballast resistors. The AP8803 switches at frequency up to 700kHz. This allows the use of small size external components, hence minimizing the PCB area needed.

Maximum output current of AP8803 is set via an external resistor connected between the  $V_{IN}$  and SET input pins. Dimming is achieved by applying either a DC voltage or a PWM signal at the CTRL input pin. An input voltage of 0.2V or lower at CTRL shuts down the output at SW and puts the device into a low-current standby state.

## Features

- LED Driving Current up to 1A
- High Efficiency Up to 92%
- Operating Input Voltage Up to 30V
- High Switching Frequency Up to 700kHz
- PWM/DC Input for Dimming Control
- Built-In Output Open-Circuit Protection
- TSOT25: Available in "Green" Molding Compound (No Br, Sb) with lead Free Finish/ RoHS Compliant
  - **Totally Lead-Free & Fully RoHS Compliant (Notes 1 & 2)**
  - **Halogen and Antimony Free. "Green" Device (Note 3)**

Notes: 1. No purposely added lead. Fully EU Directive 2002/95/EC (RoHS) & 2011/65/EU (RoHS 2) compliant.  
 2. See <http://www.diodes.com> for more information about Diodes Incorporated's definitions of Halogen and Antimony free, "Green" and Lead-Free.  
 3. Halogen and Antimony free "Green" products are defined as those which contain <900ppm bromine, <900ppm chlorine (<1500ppm total Br + Cl) and <1000ppm antimony compounds.

## Pin Assignments

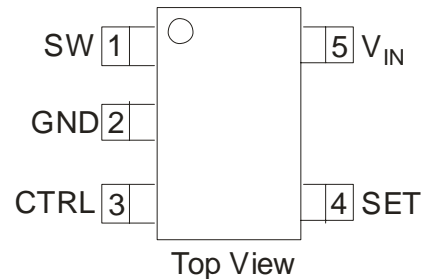

## Typical Applications Circuit

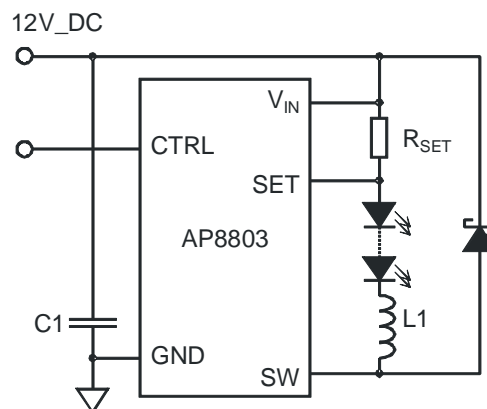

## Pin Descriptions

Pin Name	Function
SW	Switch Pin. Connect inductor/freewheeling diode here, minimizing track length at this pin to reduce EMI.
GND	GND pin
SET	Set Nominal Output Current Pin. Configure the output current of the device.
CTRL	Dimming and On/Off Control Input. <ul style="list-style-type: none"> <li>Leave floating for normal operation. (<math>V_{CTRL} = V_{REF} = 1.25V</math> giving nominal average output current <math>I_{OUTnom} = 0.1/R_S</math>)</li> <li>Drive to voltage below 0.2V to turn off output current</li> <li>Drive with DC voltage (<math>0.3V &lt; V_{CTRL} &lt; 1.25V</math>) to adjust output current from 25% to 100% of <math>I_{OUTnom}</math></li> <li>Input voltage of 0.2V or lower forces the device into low current standby mode and shuts off the output. A PWM signal allows the output current to be adjusted above or below the level set by the resistor connected to SET input pin.</li> </ul>
V <sub>IN</sub>	Input Supply Pin. Must be locally decoupled to GND with $\geq 2.2\mu F$ X7R ceramic capacitor.

## Functional Block Diagram

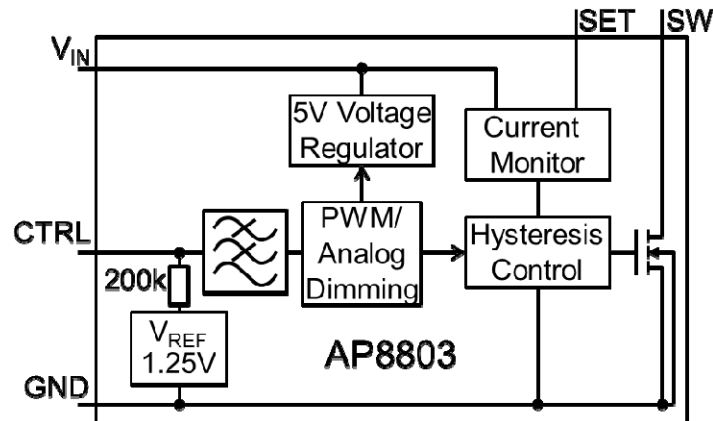

## Absolute Maximum Ratings (@T<sub>A</sub> = +25°C, unless otherwise specified.)

Symbol	Parameter	Rating	Unit
V <sub>IN</sub>	Continuous V <sub>IN</sub> pin voltage	-0.3 to +30	V
	Transient (t < 0.5s)	40	
V <sub>SW</sub>	SW voltage	-0.3 to +30	V
	Transient (t < 0.5s)	40	
V <sub>CTRL</sub>	CTRL pin input voltage	-0.3 to +6	V
I <sub>SW</sub>	Switch current	1.25	A
ESD <sub>HBM</sub>	Human Body Model ESD	500	V
ESD <sub>MM</sub>	Machine Model ESD	<100	V
T <sub>J</sub>	Junction Temperature	150	°C
T <sub>LEAD</sub>	Lead Temperature Soldering	300	°C
T <sub>ST</sub>	Storage Temperature Range	-65 to +150	°C

Caution: Stresses greater than the 'Absolute Maximum Ratings' specified above, may cause permanent damage to the device. These are stress ratings only; functional operation of the device at these or any other conditions exceeding those indicated in this specification is not implied. Device reliability may be affected by exposure to absolute maximum rating conditions for extended periods of time.

Semiconductor devices are ESD sensitive and may be damaged by exposure to ESD events. Suitable ESD precautions should be taken when handling and transporting these devices

---

### Recommended Operating Conditions (@T<sub>A</sub> = +25°C, unless otherwise specified.)

---

Symbol	Parameter	Min	Max	Unit
V <sub>IN</sub>	Operating Input Voltage	8.0	30	V
V <sub>CTRLH</sub>	Voltage High	0.3	2.5	V
V <sub>CTRL</sub>	Voltage Low		0.25	V
I <sub>SW</sub>	Continuous Switch Current (Note 5)		1	A
T <sub>A</sub>	Ambient Temperature Range	-40	+125	°C
Duty Cycle	Using Inductor ≥ 100μH (Note 4)	0.1	0.95	

- Notes:
- For most applications the LED current will be within 8% over the duty cycle range specified. Duty cycle accuracy is also dependent on propagation delay. Smaller size inductors can be used but LED current accuracy may be greater than 8% at extremes of duty cycle. This is most noticeable at low duty cycles (less than 0.1) or when the input voltage is high and only one LED is being driven.
  - Refer to Figure 8 for the device derating curve.

---

### Electrical Characteristics (@T<sub>A</sub> = +25°C, unless otherwise specified.)

---

Symbol	Parameter	Conditions	Min	Typ	Max	Unit
V <sub>INSU</sub>	Internal Regulator Start-Up Threshold	V <sub>IN</sub> rising		5.65		V
V <sub>INSD</sub>	Internal Regulator Shutdown Threshold	V <sub>IN</sub> falling		5.55		V
I <sub>Q</sub>	Quiescent Current	CTRL pin floating f = 250kHz		1.8	5	mA
V <sub>THD</sub>	Internal Threshold Voltage		92	100	108	mV
I <sub>SET</sub>	SET Pin Input Current	V <sub>SET</sub> = V <sub>IN</sub> - 0.1		1.25	10	μA
V <sub>REF</sub>	Internal Reference Voltage			1.25		V
R <sub>DS(on)</sub>	On Resistance of MOSFET	I <sub>SW</sub> = 1A		0.5	1	Ω
I <sub>SW</sub>	Continuous Switch Current	(Note 5)			1	A
I <sub>SW_Leakage</sub>	Switch Leakage Current				8	μA
f <sub>OSC</sub>	Switching Frequency				0.7	MHz
θ <sub>JA</sub>	Thermal Resistance Junction-to-Ambient	TSOT25 (Note 6)		125		°C/W

- Notes:
- Refer to Figure 8 for the device derating curve.
  - Test condition for TSOT25: Device mounted on FR-4 PCB, 25mm x 25mm, 2oz copper, minimum recommended pad layout on top layer and thermal vias to bottom layer ground plane. For better thermal performance, larger copper pad for heat-sink is needed.

## Application Information

### AP8803 Operation

The AP8803 is a hysteretic LED current switching regulator sometimes known as an equal ripple switching regulator. In normal operation, when voltage is applied at +V<sub>IN</sub> (See Figure 1), the AP8803 internal switch is turned on. Current starts to flow through sense resistor R<sub>SET</sub>, inductor L1, and the LEDs. The current ramps up linearly, and the ramp rate is determined by the input voltage +V<sub>IN</sub>, and the inductor L1 (See Figure 2).

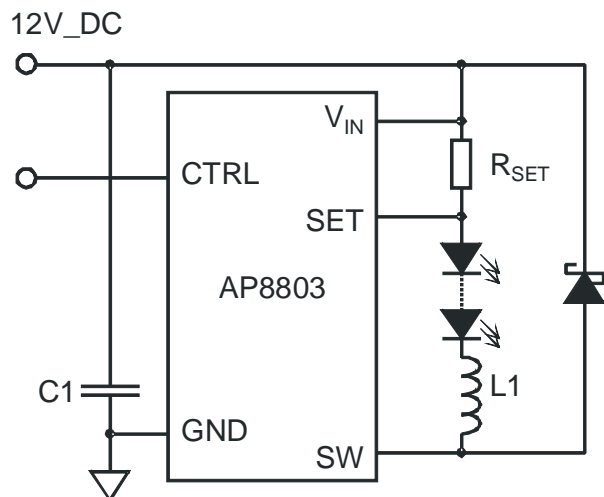

Figure 1 Typical configuration

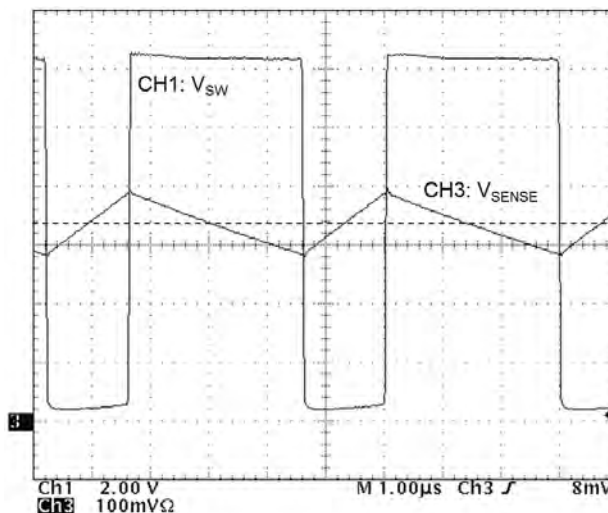

Figure 2 Typical switching waveform

This rising current produces a voltage ramp across R<sub>SET</sub>. The internal circuit of the AP8803 senses the voltage across R<sub>SET</sub> and applies a proportional voltage to the input of the internal comparator.

When this voltage reaches an internally set upper threshold, the internal switch is turned off. The inductor current continues to flow through R<sub>SET</sub>, L1, the LEDs and the schottky diode D1, and back to the supply rail, but it decays, with the rate of decay determined by the forward voltage drop of the LEDs and the schottky diode.

This decaying current produces a falling voltage at R<sub>SET</sub>, which is sensed by the AP8803. A voltage proportional to the sense voltage across R<sub>SET</sub> is applied at the input of the internal comparator. When this voltage falls to the internally set lower threshold, the internal switch is turned on again. This switch-on-and-off cycle continues to provide the average LED current set by the sense resistor R<sub>SET</sub>, with a switching current determined by the input voltage and LED chain voltage.

In normal operation the off time is relatively constant (determined mainly by the LED chain voltage) with only the on-time varying as the input voltage changes. At duty cycles up to around 80% the ramp of the LED/switch current is very linear; however, as the duty cycle approaches 95% the LED current ramp starts to become more exponential. This has two effects:

1. The overall on time starts to increase lowering the overall switching frequency.
2. The average LED current starts to increase – which may impact accuracy.

### LED Current Control

The LED current is controlled by the resistor R<sub>SET</sub> in Figure 1.

Connected between V<sub>IN</sub> and SET the nominal average output current in the LED(s) is defined as:

$$I_{LED} = \frac{V_{TH}}{R_{SET}} \quad \text{where } V_{TH} \text{ is nominally } 100\text{mV}$$

## Application Information (cont.)

### Inductor Selection

A 33 $\mu$ H inductor (or higher) is recommended for most AP8803 applications with input voltage at 24V.

Figure 3 displays the resulting switching frequency varying the main circuit parameters: Supply voltage, inductor value and number of LEDs to be driven.

In particular, the graph in Figure 3 gives values of nominal switching frequency for several values of inductors (L1) in the typical application circuit shown on Figure 1, for different input voltages and load condition. It can be used to determine the inductor value based on the desired switching frequency and the input and load conditions.

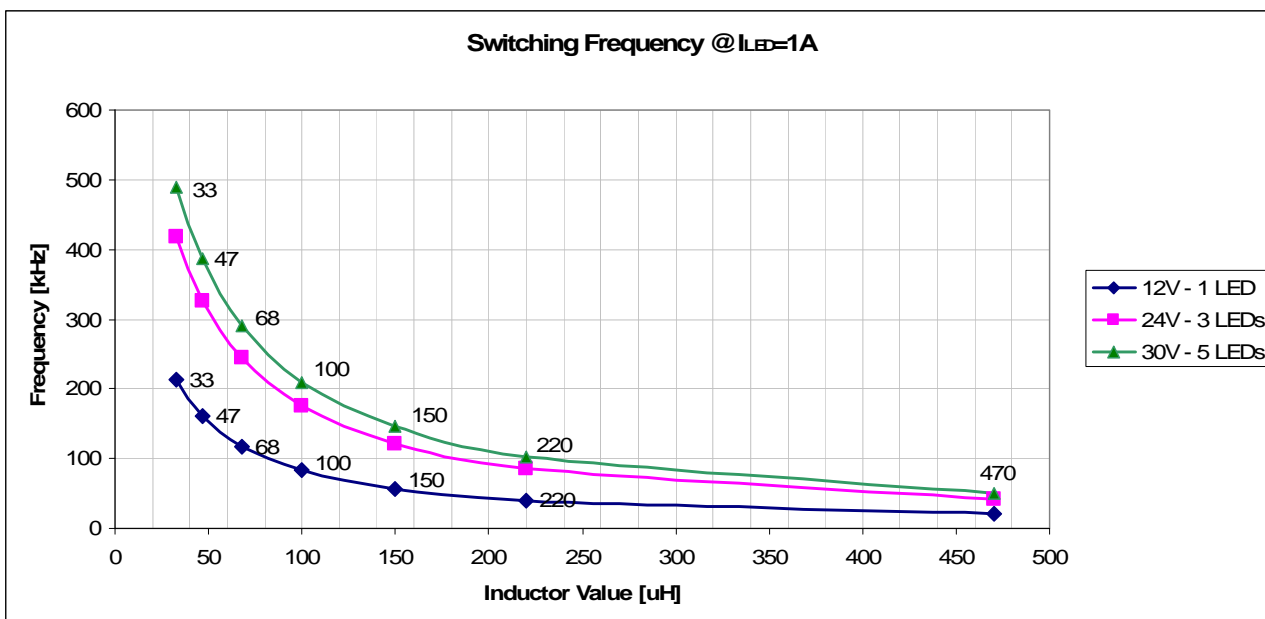

**Figure 3 Switching Frequency vs. Supply Voltage, Inductor, and Number of LEDs**

### Capacitor Selection

The small size of ceramic capacitors makes them ideal for AP8803 applications. X5R and X7R types are recommended because they retain their capacitance over wider voltage and temperature ranges than other types such as Z5U. A 2.2 $\mu$ F input capacitor is sufficient for most intended applications of AP8803.

### Diode Selection

Schottky diodes, e.g. B240 or DFSL240L in the proprietary PowerDI123 package, with their low forward voltage drop and fast reverse recovery, are the ideal choice for AP8803 applications.

In addition, Super Barrier Rectifier devices (as SBR2A40P1) can be used for their enhanced thermal performances.

## Application Information (cont.)

### LED Current Dimming

The LED current can be dimmed in two ways;

1. **Analog Dimming:** Where a DC voltage is applied to the CTRL pin.  
or
2. **PWM Dimming:** Where a Pulse Width Modulated (PWM) signal is applied to the CTRL pin.

#### Analog Dimming

If the CTRL pin is driven by an external voltage (lower than 2.5V), the average LED current is:

$$I_{LED} = \frac{V_{CTRL}}{V_{REF}} \frac{V_{THD}}{R_{SET}}$$

A DC signal from 0.3V to 2.5V applied to the CTRL pin will vary the LED current from 24% to 200% of nominal LED current. This gives an approximate 8:1 dimming range; care, should be exercised when overdriving the CTRL pin to 200% of nominal LED current not to exceed the power dissipation of the package.

The graph in Figure 4 shows values of nominal average output current for 3 values of current setting resistor ( $R_{SET}$ ) in the typical application circuit shown on Figure 1, for different voltages applied on the CTRL pin.

It can be used to determine the  $R_{SET}$  value based on the desired LED current and the condition of the CTRL pin (floating or driven with an external DC voltage lower than 2.5V and higher than 0.2V).

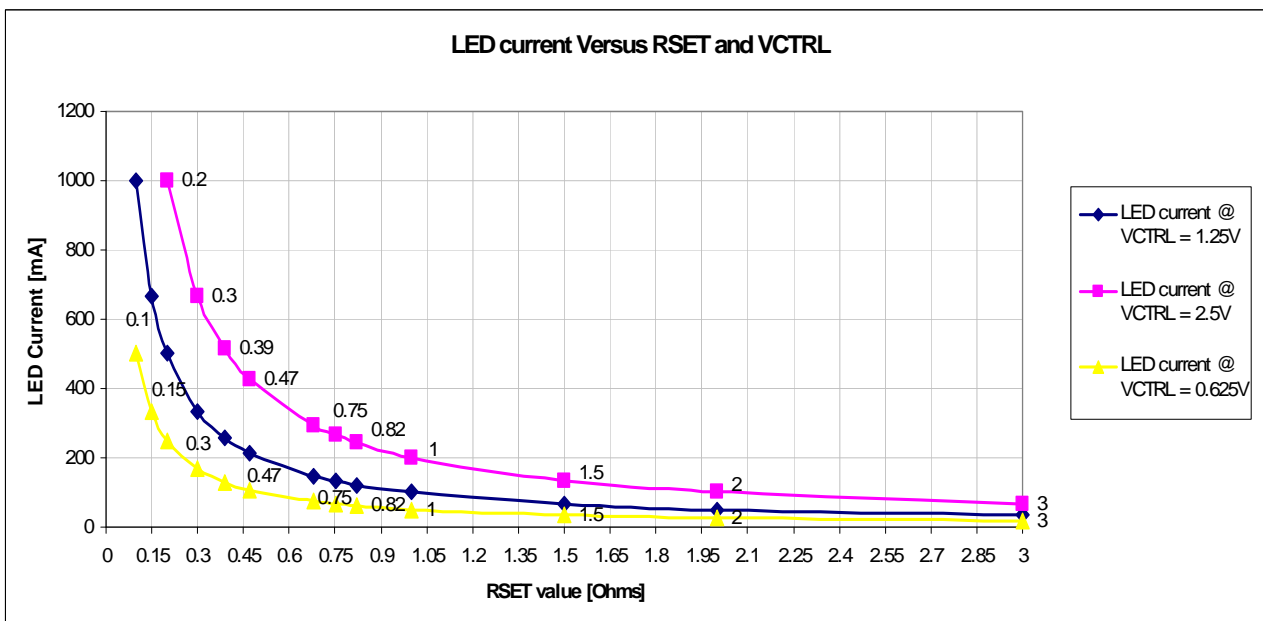

Figure 4 LED Current Setting vs.  $R_{SET}$  and  $V_{CTRL}$

**Application Information** (cont.)

**PWM Dimming**

A Pulse Width Modulated (PWM) signal with a max resolution of 8-bit, can be applied to the CTRL pin to change the output current to a value above or below the nominal average value set by resistor  $R_{SET}$ . To achieve this resolution the PWM frequency has to be lower than 500Hz.

Figure 5 shows the typical PWM response of the AP8800A. An internal filter produces a ramp

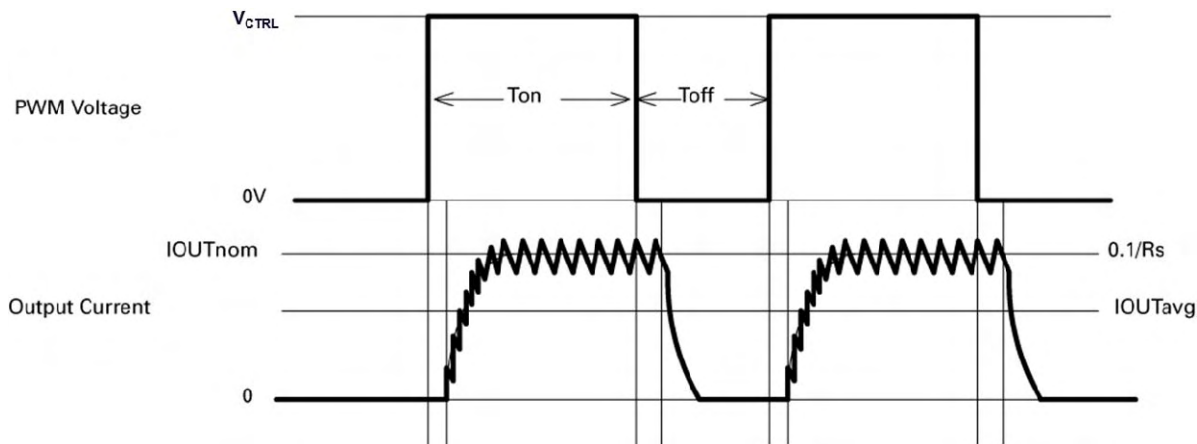

**Figure 5 Typical PWM Dimming Waveform**

The recommended method of driving the CTRL pin and controlling the amplitude of the PWM waveform is to use a small NPN switching transistor as shown below:

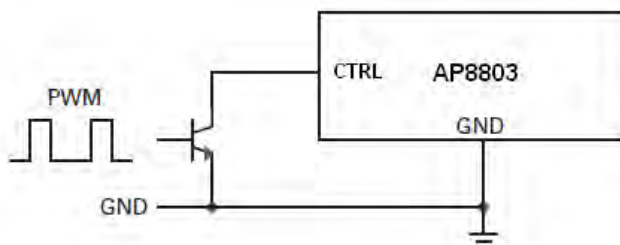

**Figure 6 Open Collector PWM Dimming Circuit**

This scheme uses the internal 200kΩ resistor between the CTRL pin and the internal voltage reference as a pull-up resistor for the external transistor eg MMBT3904.

**Soft-Start**

An external capacitor from the CTRL pin to ground will provide soft-start delay, by increasing the time taken for the voltage on this pin to rise to the turn-on threshold and by slowing down the rate of rise of the control voltage at the input of the comparator.

The soft-start time is 0.5ms/nF.

**Application Information** (cont.)

**Fault Condition Operation**

The AP8803 has by default open LED protection. If the LEDs should become open circuit the AP8803 will stop oscillating; the SET pin will rise to  $V_{IN}$  and the SW pin will then fall to GND. No excessive voltages will be seen by the AP8803.

If the LEDs should become shorted together the AP8803 will continue to switch however the duty cycle at which it will operate will change dramatically and the switching frequency will most likely decrease. The on-time of the internal power MOSFET switch will be significantly reduced because almost all of the input voltage is now developed across the inductor. The off-time will be significantly increased because the reverse voltage across the inductor is now just the Schottky diode voltage (See Figure 7) causing a much slower decay in inductor current. During this condition the inductor current will remain within its controlled levels and so no excessive heat will be generated within the AP8803.

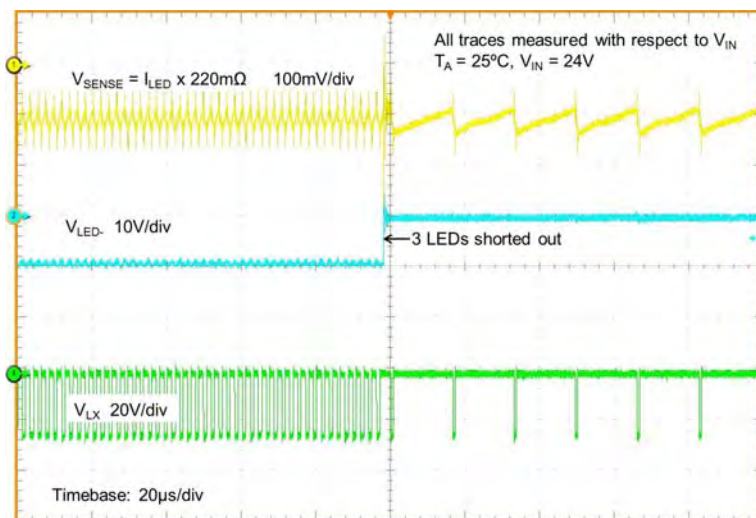

**Figure 7 Switching Characteristics (normal open to short LED chain)**

**Thermal Considerations**

The graph below in Figure 8, gives details for power dissipation derating. This assumes the device to be mounted on a 25 x 25mm PCB with 1oz copper standing in still air.

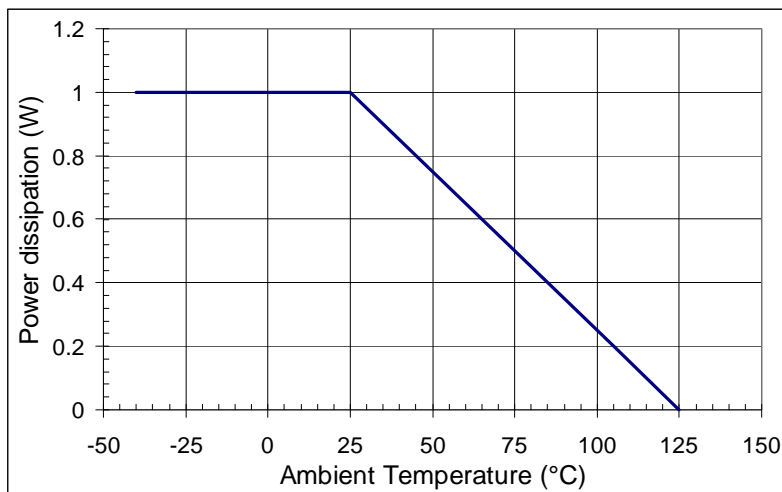

**Figure 8 Power Dissipation Derating Curve**

The maximum power dissipation is affected by PCB area and the area of copper associated with the LX pin as well as other components on the PCB generating heat – such as the inductor, capacitor or rectifiers.

**Ordering Information**

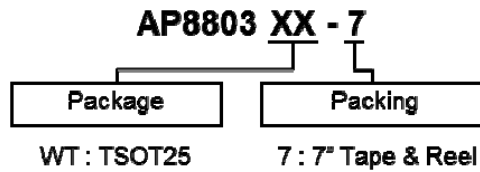

Part Number	Package Code	Packaging	7" Tape and Reel	
			Quantity	Part Number Suffix
AP8803WTG-7	WT	TSOT25	3000/Tape & Reel	-7

**Marking Information**

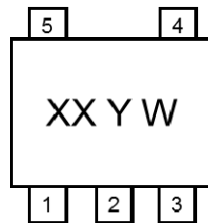

XX : Identification Code  
 Y : Year 0~9  
 W : Week: A~Z: 1~26 week  
       a~z: 27~52 week;  
       z represents 52 and 53 week

Part Number	Package	Identification Code
AL8803WT-7	TSOT25	AY

**Package Outline Dimensions** (All dimensions in mm.)

Please see AP02002 at <http://www.diodes.com/datasheets/ap02002.pdf> for latest version.

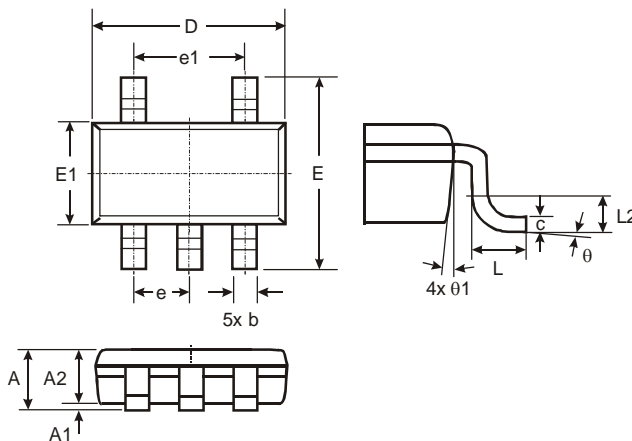

TSOT25			
Dim	Min	Max	Typ
A	-	1.00	-
A1	0.01	0.10	-
A2	0.84	0.90	-
D	-	-	2.90
E	-	-	2.80
E1	-	-	1.60
b	0.30	0.45	-
c	0.12	0.20	-
e	-	-	0.95
e1	-	-	1.90
L	0.30	0.50	-
L2	-	-	0.25
θ	0°	8°	4°
θ1	4°	12°	-
All Dimensions in mm			

## Suggested Pad Layout

Please see AP02001 at <http://www.diodes.com/datasheets/ap02001.pdf> for the latest version.

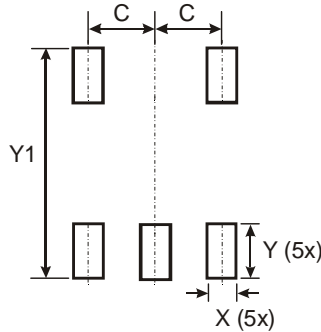

Dimensions	Value (in mm)
C	0.950
X	0.700
Y	1.000
Y1	3.199

### IMPORTANT NOTICE

DIODES INCORPORATED MAKES NO WARRANTY OF ANY KIND, EXPRESS OR IMPLIED, WITH REGARDS TO THIS DOCUMENT, INCLUDING, BUT NOT LIMITED TO, THE IMPLIED WARRANTIES OF MERCHANTABILITY AND FITNESS FOR A PARTICULAR PURPOSE (AND THEIR EQUIVALENTS UNDER THE LAWS OF ANY JURISDICTION).

Diodes Incorporated and its subsidiaries reserve the right to make modifications, enhancements, improvements, corrections or other changes without further notice to this document and any product described herein. Diodes Incorporated does not assume any liability arising out of the application or use of this document or any product described herein; neither does Diodes Incorporated convey any license under its patent or trademark rights, nor the rights of others. Any Customer or user of this document or products described herein in such applications shall assume all risks of such use and will agree to hold Diodes Incorporated and all the companies whose products are represented on Diodes Incorporated website, harmless against all damages.

Diodes Incorporated does not warrant or accept any liability whatsoever in respect of any products purchased through unauthorized sales channel. Should Customers purchase or use Diodes Incorporated products for any unintended or unauthorized application, Customers shall indemnify and hold Diodes Incorporated and its representatives harmless against all claims, damages, expenses, and attorney fees arising out of, directly or indirectly, any claim of personal injury or death associated with such unintended or unauthorized application.

Products described herein may be covered by one or more United States, international or foreign patents pending. Product names and markings noted herein may also be covered by one or more United States, international or foreign trademarks.

### LIFE SUPPORT

Diodes Incorporated products are specifically not authorized for use as critical components in life support devices or systems without the express written approval of the Chief Executive Officer of Diodes Incorporated. As used herein:

A. Life support devices or systems are devices or systems which:

1. are intended to implant into the body, or
2. support or sustain life and whose failure to perform when properly used in accordance with instructions for use provided in the labeling can be reasonably expected to result in significant injury to the user.

B. A critical component is any component in a life support device or system whose failure to perform can be reasonably expected to cause the failure of the life support device or to affect its safety or effectiveness.

Customers represent that they have all necessary expertise in the safety and regulatory ramifications of their life support devices or systems, and acknowledge and agree that they are solely responsible for all legal, regulatory and safety-related requirements concerning their products and any use of Diodes Incorporated products in such safety-critical, life support devices or systems, notwithstanding any devices- or systems-related information or support that may be provided by Diodes Incorporated. Further, Customers must fully indemnify Diodes Incorporated and its representatives against any damages arising out of the use of Diodes Incorporated products in such safety-critical, life support devices or systems.

Copyright © 2012, Diodes Incorporated

[www.diodes.com](http://www.diodes.com)

## Looking for pricing, stock, or lifecycle information?

Click below to explore more details on WIN SOURCE:

 [View AP8803WTG-7 on WIN SOURCE](#)

 [Diodes Incorporated](#) Information

## Optimize Your Supply Chain with WIN SOURCE Solutions

-  Global Sourcing Solution
-  Obsolete Management
-  Cost Control Management
-  Shortage Management
-  Alternative Solution
-  Excess Inventory Management