



THE DATASHEET OF
AP8800SG-13



Description

The AP8800 is a step-down DC/DC converter designed to drive LEDs with a constant current. The device can drive up to seven LEDs, depending on the forward voltage of the LEDs, in series from a voltage source of 8V to 28V. Series connection of the LEDs provides identical LED currents resulting in uniform brightness and eliminates the need for ballast resistors. The AP8800 switches at frequency up to 0.6MHz. This allows the use of small size external components, hence minimizing the PCB area needed.

Maximum output current of AP8800 is set via an external resistor connected between the V_{IN} and SET input pins. Dimming is achieved by applying either a DC voltage or a PWM signal at the CTRL input pin. An input voltage of 0.2V or lower at CTRL shuts down the output at SW and puts the device into a low-current standby state.

Features

- LED Driving Current up to 350mA
- Compatible with 12V & 24V Standard Systems
- High Efficiency up to 92%
- High Switching Frequency up to 0.6MHz
- PWM/DC Input for Dimming Control
- Built-in Soft-Start Function
- Built-in Output Open-Circuit Protection
- SO-8, MSOP-8 and U-DFN3030-10: Available in "Green" Molding Compound (No Br, Sb) with lead Free Finish/ RoHS Compliant
- **Totally Lead-Free & Fully RoHS Compliant (Notes 1 & 2)**
- **Halogen and Antimony Free. "Green" Device (Note 3)**

Applications

- Commercial & Industrial Lighting
- Small LCD Panel Backlight
- Architecture Detail Lighting
- Appliances Interior Lighting

Notes:

1. No purposely added lead. Fully EU Directive 2002/95/EC (RoHS), 2011/65/EU (RoHS 2) & 2015/863/EU (RoHS 3) compliant.
2. See <https://www.diodes.com/quality/lead-free/> for more information about Diodes Incorporated's definitions of Halogen- and Antimony-free, "Green" and Lead-free.
3. Halogen and Antimony free "Green" products are defined as those which contain <900ppm bromine, <900ppm chlorine (<1500ppm total Br + Cl) and <1000ppm antimony compounds.

Typical Applications Circuit

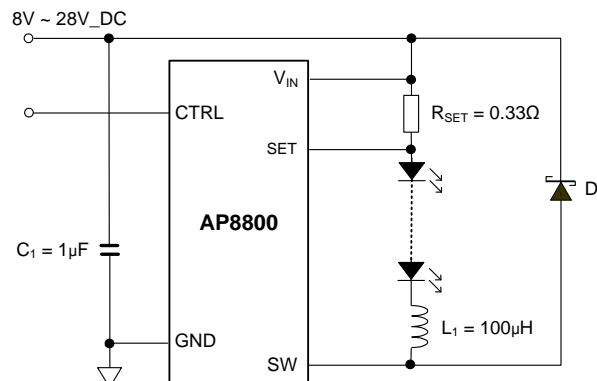

Pin Assignments

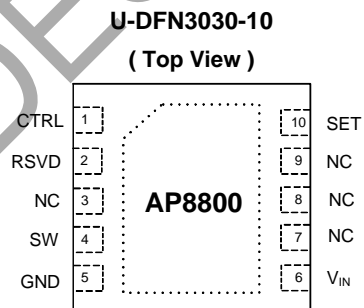
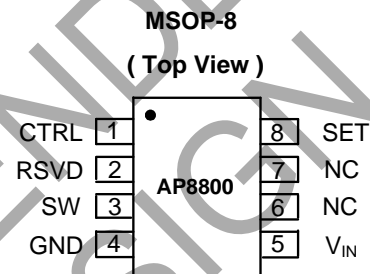
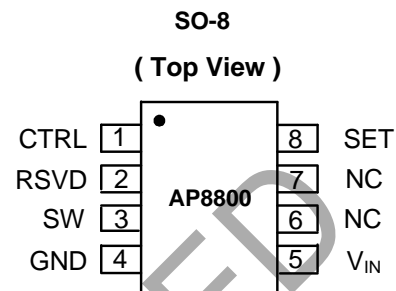

Pin Descriptions

Pin Name	Pin Number			Function
	SO-8	MSOP-8	U-DFN3030-10	
SW	3	3	4	Switch Pin. Connect inductor/freewheeling diode here. Minimize trace area at this pin to reduce EMI.
GND	4	4	5	GND Pin
SET	8	8	10	Set Nominal Output Current Pin. To configure the output current of the device.
CTRL	1	1	1	Dual function dimming control pin. <ul style="list-style-type: none"> Input voltage of 0.2V or lower forces the device into low current standby mode and shuts off the output. A PWM signal (driven by an open-drain/collector source) allows the output current to be adjusted over a wide range up to 100%. An analog voltage between 0.3V and 2.5V adjusts the output current between 25% and 200% of the current set by 0.2V/R_s. The input impedance is about 200kΩ, and if the pin is left open V _{CTRL} = V _{REF}
V _{IN}	5	5	6	Input Supply Pin. Must be locally bypassed.
RSVD	2	2	2	Reserved. Normally connected to Ground
NC	6, 7	6, 7	2, 7, 8, 9	No Connection.

Functional Block Diagram

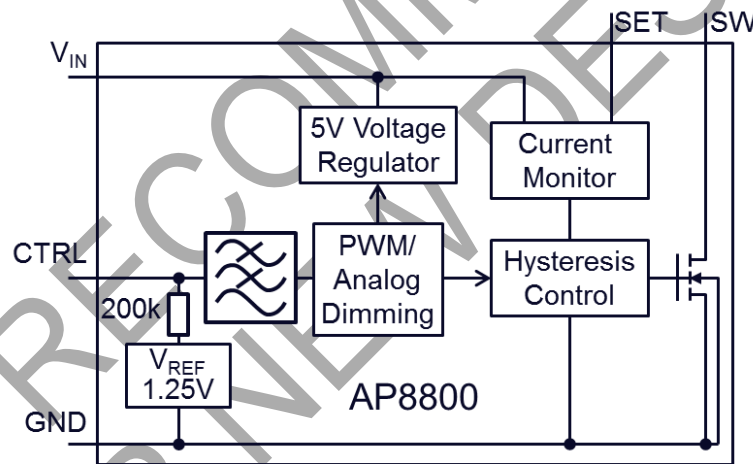

Absolute Maximum Ratings (@T_A = +25°C, unless otherwise specified.)

Symbol	Parameter	Rating	Unit
V _{IN}	V _{IN} Pin Voltage	-0.3 to +30	V
V _{SET}	Set Voltage Relative to V _{IN}	V _{IN} -5 to V _{IN} +0.3	V
V _{SW}	SW Voltage	-0.3 to +30	V
V _{CTRL}	CTRL Pin Input Voltage	-0.3 to +5	V
T _J	Maximum Junction Temperature	+125	°C
T _{LEAD}	Maximum Lead Temperature	+300	°C
T _{ST}	Storage Temperature Range	-55 to +125	°C

Caution: Stresses greater than the 'Absolute Maximum Ratings' specified above, may cause permanent damage to the device. These are stress ratings only; functional operation of the device at these or any other conditions exceeding those indicated in this specification is not implied. Device reliability may be affected by exposure to absolute maximum rating conditions for extended periods of time.

Semiconductor devices are ESD sensitive and may be damaged by exposure to ESD events. Suitable ESD precautions should be taken when handling and transporting these devices.

Recommended Operating Conditions (@T_A = +25°C, unless otherwise specified.)

Symbol	Parameter	Min	Max	Unit
V _{IN}	Operating Input Voltage relative to GND	8.0	28	V
V _{CTRLDC}	Voltage Range for 24% to 200% DC Dimming Relative to GND (Note 4)	0.3	2.5	V
V _{CTRLLL}	Voltage Low for PWM Dimming Relative to GND	0	0.2	V
f _{OSC}	Maximum Switching Frequency	—	500	kHz
T _A	Ambient Temperature Range	-40	+85	°C
Duty Cycle	Using Inductor ≥ 100μH (Note 5)	0.1	0.95	—
V _{ENH}	CTRL Input Voltage to Attain 100% LED Current	1.25	—	V
V _{ENL}	CTRL Input Voltage Below Which Device Turns Off	—	0.2	

- Notes:
- For 100% brightness either leave floating or connect to 1.25V relative to GND.
 - For most applications the LED current will be within 8% over the duty cycle range specified. Duty cycle accuracy is also dependent on propagation delay. Smaller size inductors can be used but LED current accuracy may be greater than 8% at extremes of duty cycle. This is most noticeable at low duty cycles (less than 0.1) or when the input voltage is high and only one LED is being driven.

Electrical Characteristics (@T_A = +25°C, unless otherwise specified.)

Symbol	Parameter	Conditions	Min	Typ	Max	Unit
I _{OUT}	Continuous Switch Current	(Note 6)	—	—	350	mA
I _Q	Quiescent Current	—	—	20	30	μA
V _{THD}	Internal Current Sense Threshold Voltage	V _{IN} - V _{SET}	92	100	108	mV
V _{REF}	Internal Reference Voltage	—	—	1.25	—	V
SET	SET Pin Input Current	V _{SET} = V _{IN} - 0.1	—	1.3	—	μA
R _{DS(ON)}	On-Resistance of Internal Switch	—	—	1.7	2.2	Ω
I _{SW_Leakage}	Switch Pin Leakage Current	—	—	—	5	μA
θ _{JA}	Thermal Resistance Junction-to-Ambient	SO-8 (Note 7)	—	92	—	°C/W
		MSOP-8 (Note 7)	—	120	—	°C/W
		U-DFN3030-10 (Note 7)	—	46	—	°C/W
θ _{JC}	Thermal Resistance Junction-to-Case	SO-8 (Note 7)	—	60	—	°C/W
		MSOP-8 (Note 7)	—	98	—	°C/W
		U-DFN3030-10 (Note 7)	—	32	—	°C/W

- Notes:
- Refer to figure 8 for the device derating curve.
 - Test condition for SO-8, MSOP-8 and U-DFN3030-10: Device mounted on FR-4 PCB, 2"x 2", 2oz copper, minimum recommended pad layout on top layer and thermal vias to bottom layer ground plane. For better thermal performance, larger copper pad for heat-sink is needed.

Application Information

AP8800 Operation

The AP8800 is a hysteretic LED current switching regulator sometimes known as an equal ripple switching regulator. In normal operation, when voltage is applied at +V_{IN} (See Figure 1), the AP8800 internal switch is turned on. Current starts to flow through sense resistor R_{SET}, inductor L₁, and the LEDs. The current ramps up linearly, and the ramp rate is determined by the input voltage +V_{IN}, and the inductor L₁ (See Figure 2).

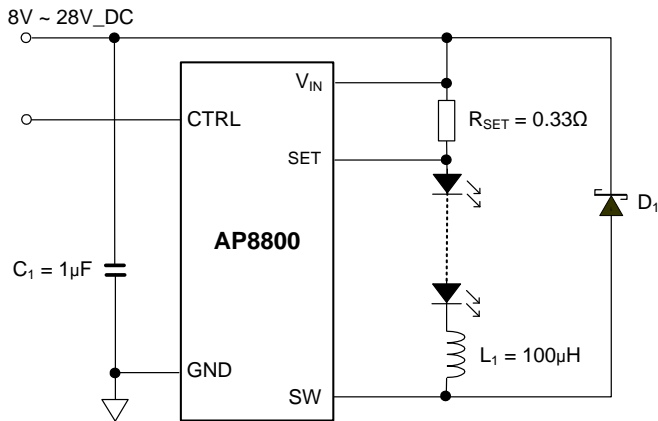

Figure 1 Typical Configuration

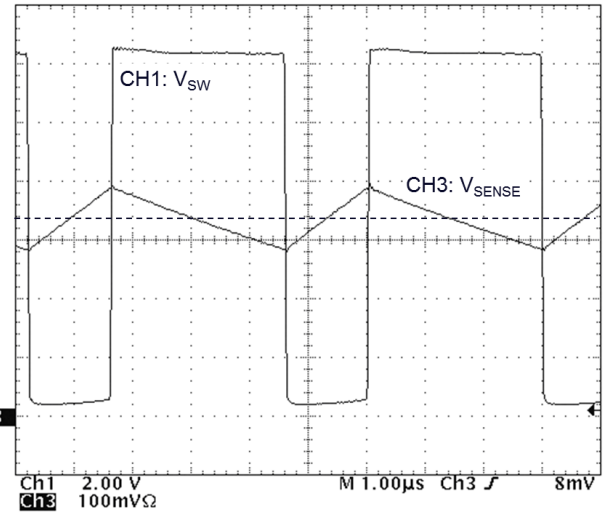

Figure 2 Typical Switching Waveform

This rising current produces a voltage ramp across R_{SET}. The internal circuit of the AP8800 senses the voltage across R_{SET} and applies a proportional voltage to the input of the internal comparator.

When this voltage reaches an internally set upper threshold, the internal switch is turned off. The inductor current continues to flow through R_{SET}, L₁, the LEDs and the schottky diode D₁, and back to the supply rail, but it decays, with the rate of decay determined by the forward voltage drop of the LEDs and the schottky diode.

This decaying current produces a falling voltage at R_{SET}, which is sensed by the AP8800. A voltage proportional to the sense voltage across R_{SET} is applied at the input of the internal comparator. When this voltage falls to the internally set lower threshold, the internal switch is turned on again. This switch-on-and-off cycle continues to provide the average LED current set by the sense resistor R_{SET}, with a switching current determined by the input voltage and LED chain voltage.

In normal operation the off time is relatively constant (determined mainly by the LED chain voltage) with only the on-time varying as the input voltage changes. At duty cycles up to around 80% the ramp of the LED/switch current is very linear; however, as the duty cycle approaches 95% the LED current ramp starts to become more exponential. This has two effects:

1. The overall on time starts to increase lowering the overall switching frequency.
2. The average LED current starts to increase – which may impact accuracy.

Application Information (Cont.)

Inductor Selection

A 100µH inductor is recommended for most AP8800 applications with input voltage at 24V.

Figure 3 displays the resulting switching frequency varying the main circuit parameters: Supply voltage, Inductor value and number of LEDs to be driven.

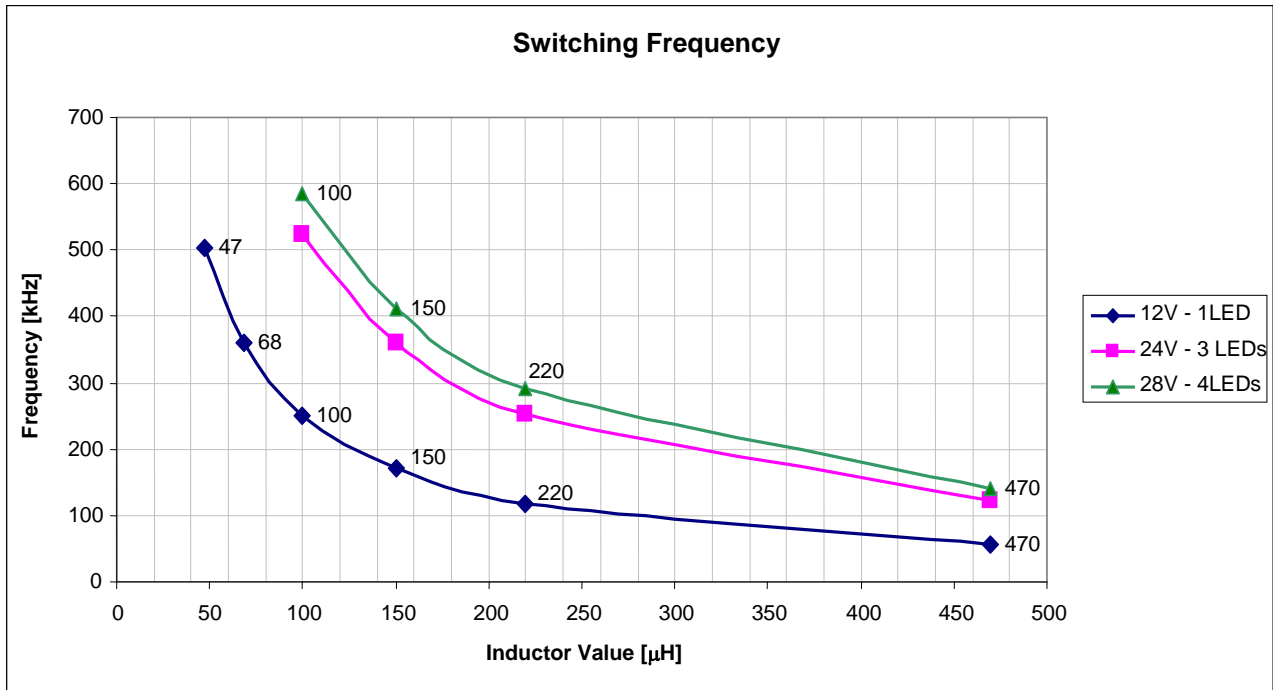

Figure 3 Switching Frequency vs. Supply Voltage, Inductor, and Number of LEDs

Capacitor Selection

The small size of ceramic capacitors makes them ideal for AP8800 applications. X5R and X7R types are recommended because they retain their capacitance over wider voltage and temperature ranges than other types such as Z5U. A 1µF input capacitor is sufficient for most intended applications of AP8800.

Diode Selection

Schottky diode, e.g. B140, with their low forward voltage drop and fast reverse recovery, is the ideal choice for AP8800 applications.

Miscellaneous

To ensure optimal performance, RSVD pin should be connected to the GND pin with the shortest trace length.

Application Information (Cont.)

LED Current Dimming

The LED current can be dimmed in two ways;

1. Analog Dimming: Where a dc voltage is applied to the CTRL pin
or
2. PWM Dimming: Where a Pulse Width Modulated (PWM) signal is applied to the CTRL pin.

Analog Dimming

If the CTRL pin is driven by an external voltage (lower than 2.5V), the average LED current in this case is:

$$I_{LED} = \frac{V_{CTRL}}{V_{REF}} \times \frac{V_{TH}}{R_{SET}}$$

A DC signal from 0.3V to 2.5V applied to the CTRL pin will vary the LED current from 24% to 200% of nominal LED current. This gives an approximate 8:1 dimming range; care, should be exercised when overdriving the CTRL pin to 200% of nominal LED current not to exceed the power dissipation of the package.

The graph in Figure 4 shows values of nominal average output current for 3 values of current setting resistor (R_{SET}) in the typical application circuit shown on Figure 1, for different voltages applied on the CTRL pin.

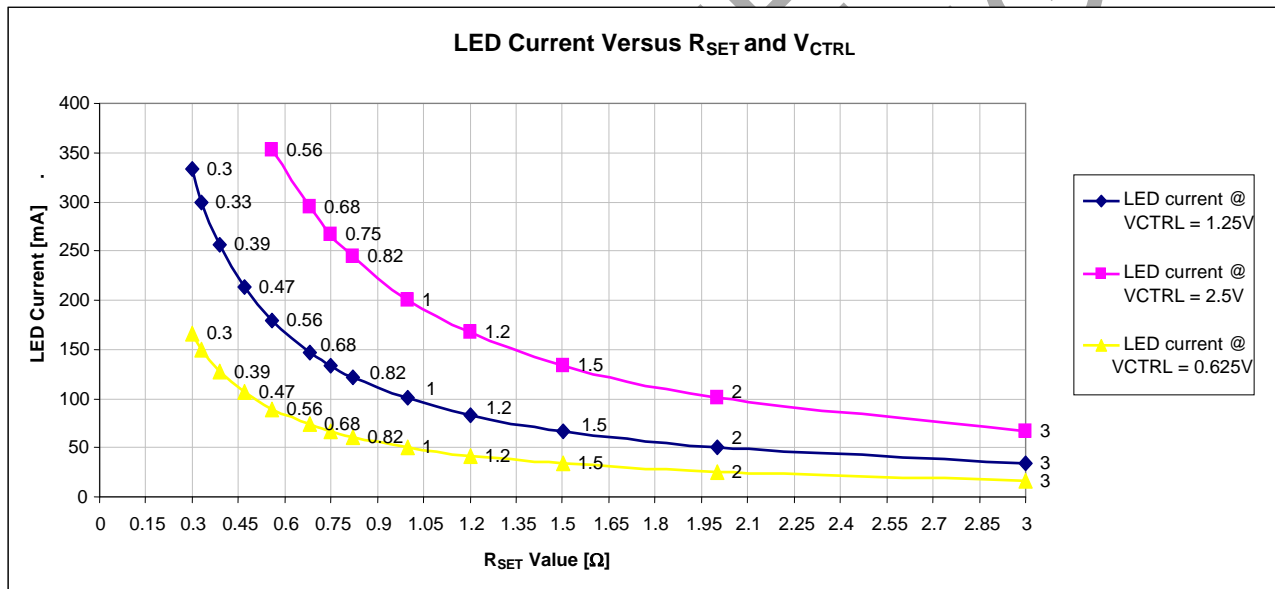

Figure 4 LED Current Setting vs. R_{SET} and V_{CTRL}

Application Information (Cont.)

PWM Dimming

A PWM signal with a max resolution of 8bit can be applied to CTRL regulate the output current to a value below the nominal average value set by resistor R_{SET} . PWM dimming gives a wider average LED current variation and is more accurate at lower average LED currents than by applying DC voltage to the CTRL pin to achieve average LED current dimming.

Figure 5 shows the typical PWM response of the AP8800A. An internal filter produces a ramp.

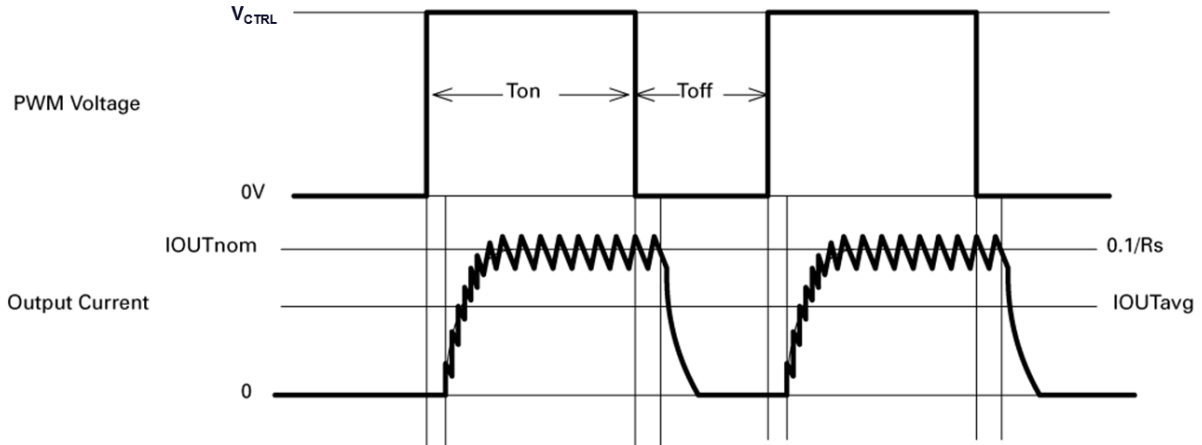

Figure 5 Typical PWM Dimming Waveform

The recommended method of driving the CTRL pin and controlling the amplitude of the PWM waveform is to use a small NPN switching transistor as shown below:

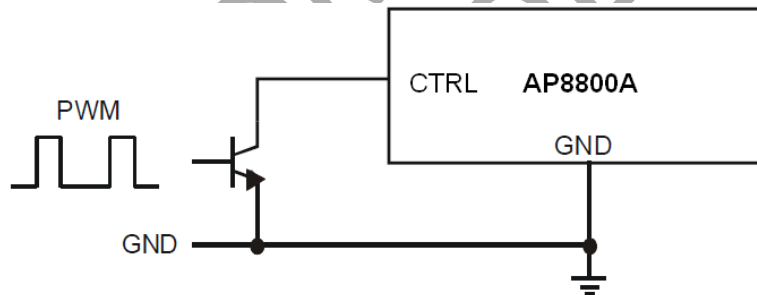

Figure 6 Open Collector PWM Dimming Circuit

This scheme uses the 200k resistor between the ADJ pin and the internal voltage reference as a pull-up resistor for the external transistor eg MMBT3904.

Soft-Start

An external capacitor from the CTRL pin to ground will provide soft-start delay, by increasing the time taken for the voltage on this pin to rise to the turn-on threshold and by slowing down the rate of rise of the control voltage at the input of the comparator.

The soft-start time is 0.5ms/nF.

Application Information (Cont.)

Fault Conditions

The AP8800 is inherently protected against open-LED conditions. If one LED becomes open circuit the device automatically stops switching and will only restart if the open-LED fault is removed.

If one or more LEDs should become shorted together then the switching frequency and duty cycle will change. If one or more LEDs get shorted together, the ramp-up time of LED current will become shorter due to there being a larger voltage across the inductor. However, the ramp-down time of the LED current will increase due to the voltage across the inductor becoming smaller.

Figure 7 below shows the AP8800 driving 3 LEDs when all 3 LEDs become shorted together. Due to the large voltage change across the inductor during both LED current ramp-up and ramp-down we see a large difference in switching frequency.

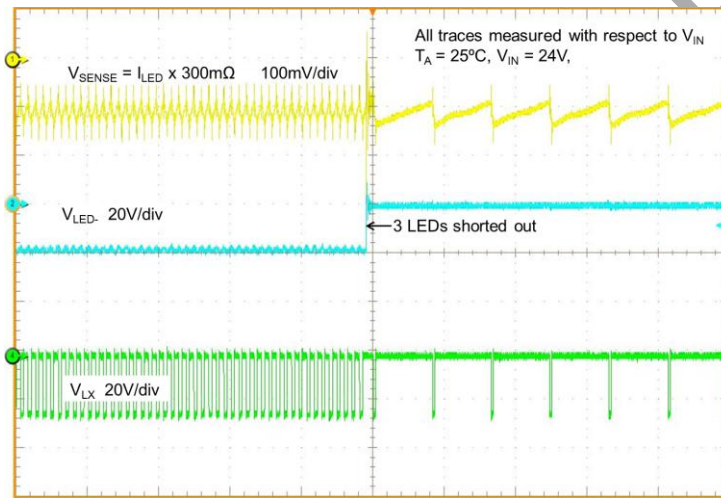

Figure 7 LED Short Fault Condition

Thermal Considerations

The graph below in Figure 8, gives details for power derating. This assumes the device to be mounted on a 25 x 25mm PCB with 1oz copper standing in still air.

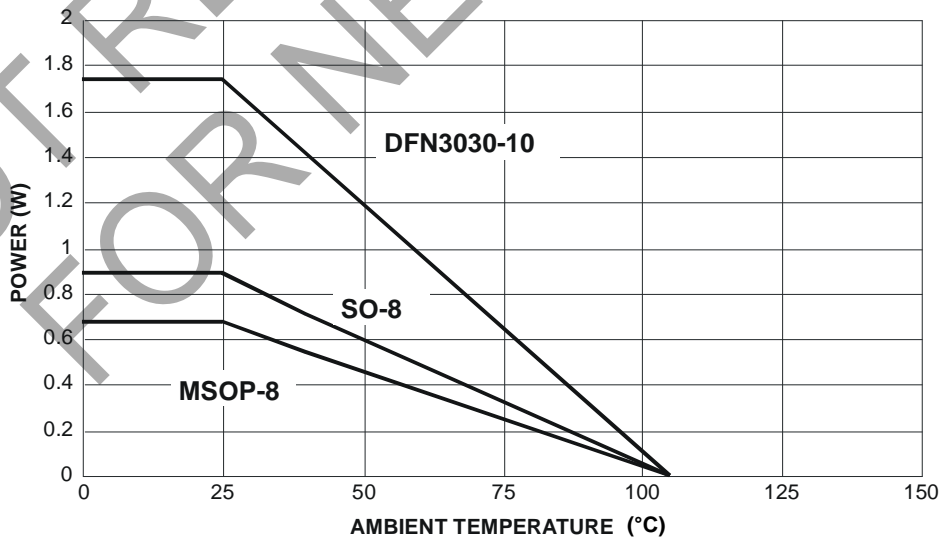
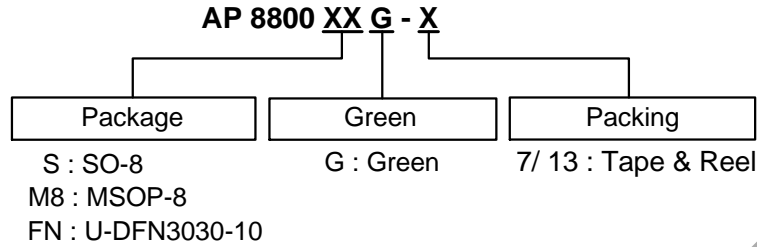

Figure 8 Power Dissipation Derating Curve

Ordering Information



Part Number	Package Code	Packaging	7"/13" Tape and Reel	
			Quantity	Part Number Suffix
AP8800SG-13	S	SO-8	2500/Tape & Reel	-13
AP8800M8G-13	M8	MSOP-8	2500/Tape & Reel	-13
AP8800FNG-7	FN	U-DFN3030-10	3000/Tape & Reel	-7

Marking Information

SO-8

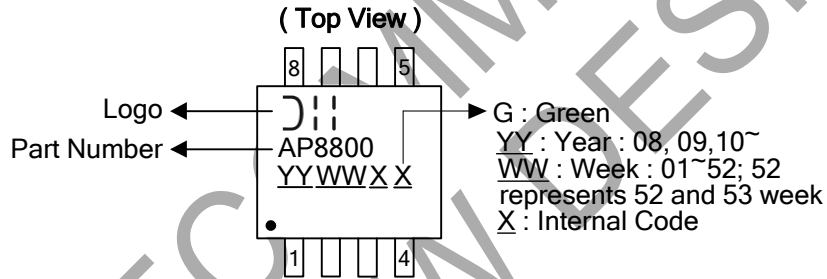

MSOP-8

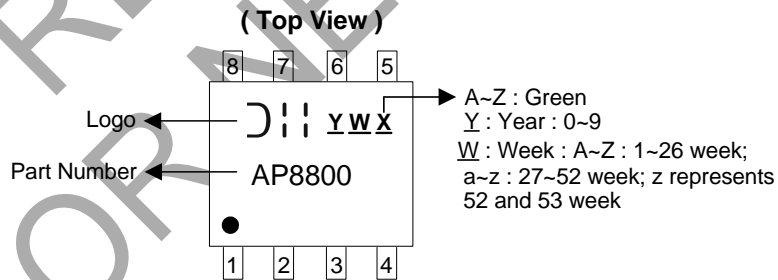

U-DFN3030-10

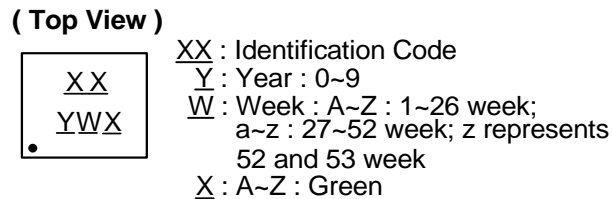

Part Number	Package	Identification Code
AP8800FNG-7	U-DFN3030-10	A4

Package Outline Dimensions (All dimensions in mm.)

Please see <http://www.diodes.com/package-outlines.html> for the latest version.

Package Type: SO-8

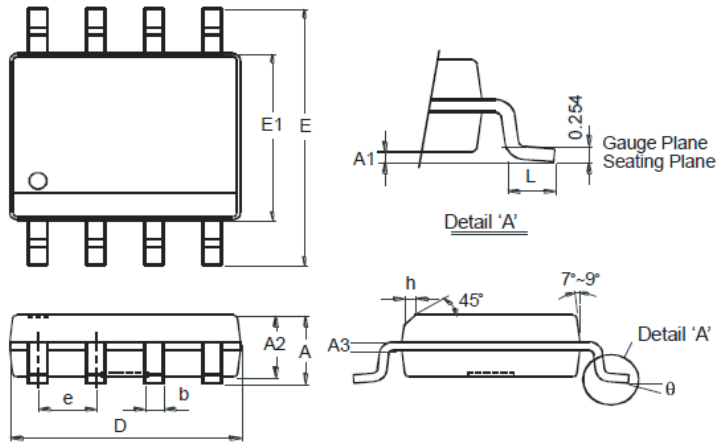

SO-8		
Dim	Min	Max
A	-	1.75
A1	0.10	0.20
A2	1.30	1.50
A3	0.15	0.25
b	0.3	0.5
D	4.85	4.95
E	5.90	6.10
E1	3.85	3.95
e	1.27 Typ	
h	-	0.35
L	0.62	0.82
θ	0°	8°
All Dimensions in mm		

Package Type: MSOP-8

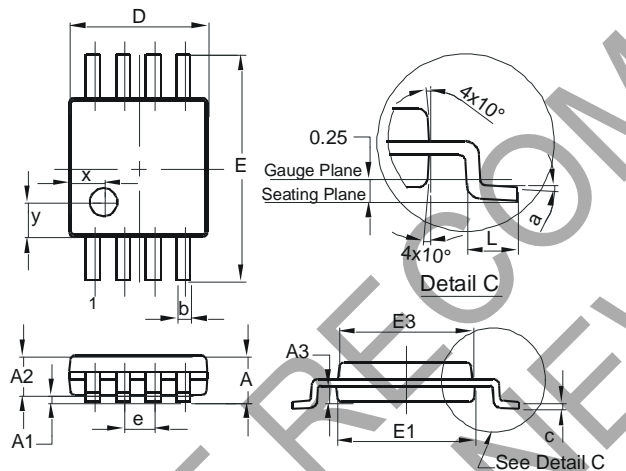

MSOP-8			
Dim	Min	Max	Typ
A	-	1.10	-
A1	0.05	0.15	0.10
A2	0.75	0.95	0.86
A3	0.29	0.49	0.39
b	0.22	0.38	0.30
c	0.08	0.23	0.15
D	2.90	3.10	3.00
E	4.70	5.10	4.90
E1	2.90	3.10	3.00
E3	2.85	3.05	2.95
e	-	-	0.65
L	0.40	0.80	0.60
a	0°	8°	4°
x	-	-	0.750
y	-	-	0.750
All Dimensions in mm			

Package Type: U-DFN3030-10

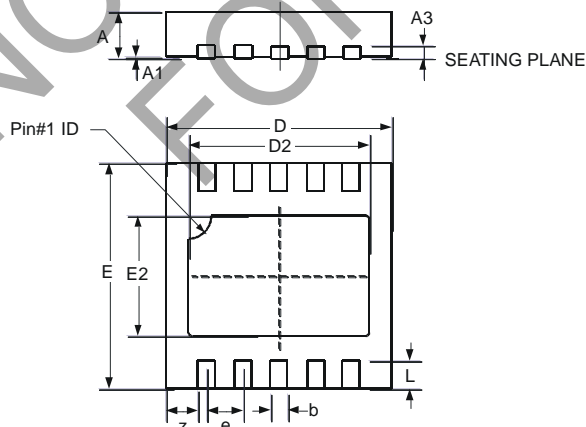

U-DFN3030-10			
Dim	Min	Max	Typ
A	0.57	0.63	0.60
A1	0	0.05	0.02
A3	—	—	0.15
b	0.20	0.30	0.25
D	2.90	3.10	3.00
D2	2.30	2.50	2.40
e	—	—	0.50
E	2.90	3.10	3.00
E2	1.50	1.70	1.60
L	0.25	0.55	0.40
z	—	—	0.375
All Dimensions in mm			

Suggested Pad Layout

Please see <http://www.diodes.com/package-outlines.html> for the latest version.

Package Type: SO-8

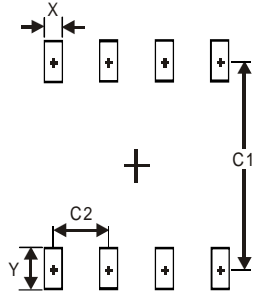

Dimensions	Value (in mm)
X	0.60
Y	1.55
C1	5.4
C2	1.27

Package Type: MSOP-8

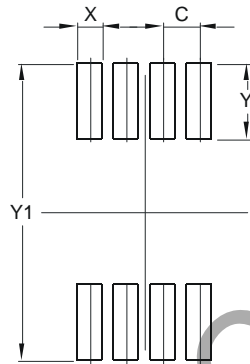

Dimensions	Value (in mm)
C	0.650
X	0.450
Y	1.350
Y1	5.300

Package Type: U-DFN3030-10

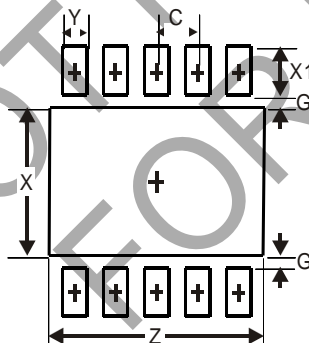

Dimensions	Value (in mm)
Z	2.60
G	0.15
X	1.80
X1	0.60
Y	0.30
C	0.50

Tape Orientation (Note 8)

For U-DFN3030-10

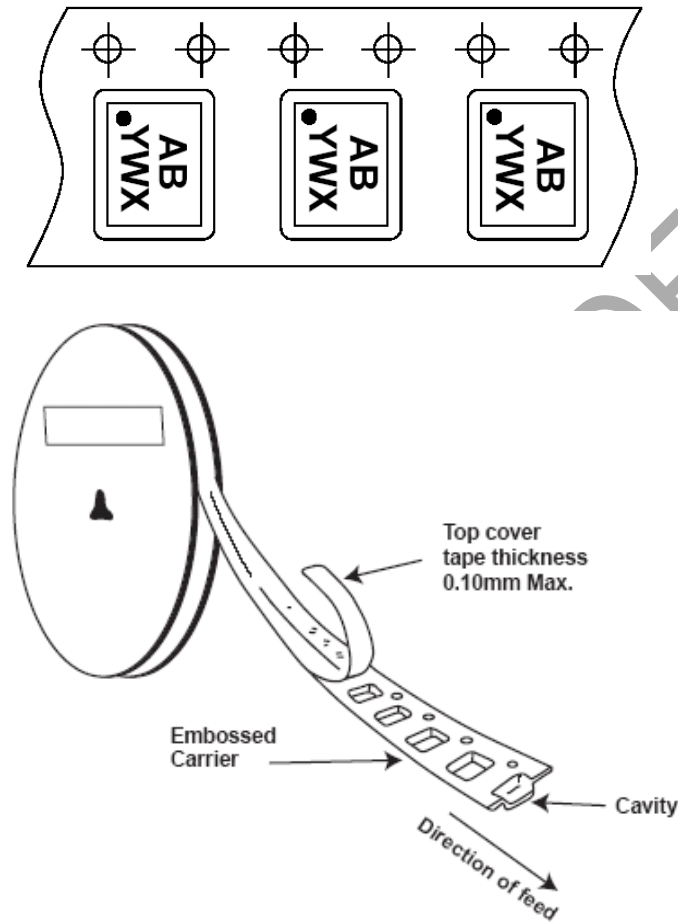

Note: 8. The taping orientation of the other package type can be found on our website at <http://www.diodes.com/datasheets/ap02007.pdf>.

IMPORTANT NOTICE

DIODES INCORPORATED MAKES NO WARRANTY OF ANY KIND, EXPRESS OR IMPLIED, WITH REGARDS TO THIS DOCUMENT, INCLUDING, BUT NOT LIMITED TO, THE IMPLIED WARRANTIES OF MERCHANTABILITY AND FITNESS FOR A PARTICULAR PURPOSE (AND THEIR EQUIVALENTS UNDER THE LAWS OF ANY JURISDICTION).

Diodes Incorporated and its subsidiaries reserve the right to make modifications, enhancements, improvements, corrections or other changes without further notice to this document and any product described herein. Diodes Incorporated does not assume any liability arising out of the application or use of this document or any product described herein; neither does Diodes Incorporated convey any license under its patent or trademark rights, nor the rights of others. Any Customer or user of this document or products described herein in such applications shall assume all risks of such use and will agree to hold Diodes Incorporated and all the companies whose products are represented on Diodes Incorporated website, harmless against all damages.

Diodes Incorporated does not warrant or accept any liability whatsoever in respect of any products purchased through unauthorized sales channel. Should Customers purchase or use Diodes Incorporated products for any unintended or unauthorized application, Customers shall indemnify and hold Diodes Incorporated and its representatives harmless against all claims, damages, expenses, and attorney fees arising out of, directly or indirectly, any claim of personal injury or death associated with such unintended or unauthorized application.

Products described herein may be covered by one or more United States, international or foreign patents pending. Product names and markings noted herein may also be covered by one or more United States, international or foreign trademarks.

This document is written in English but may be translated into multiple languages for reference. Only the English version of this document is the final and determinative format released by Diodes Incorporated.

LIFE SUPPORT

Diodes Incorporated products are specifically not authorized for use as critical components in life support devices or systems without the express written approval of the Chief Executive Officer of Diodes Incorporated. As used herein:

A. Life support devices or systems are devices or systems which:

1. are intended to implant into the body, or
2. support or sustain life and whose failure to perform when properly used in accordance with instructions for use provided in the labeling can be reasonably expected to result in significant injury to the user.

B. A critical component is any component in a life support device or system whose failure to perform can be reasonably expected to cause the failure of the life support device or to affect its safety or effectiveness.

Customers represent that they have all necessary expertise in the safety and regulatory ramifications of their life support devices or systems, and acknowledge and agree that they are solely responsible for all legal, regulatory and safety-related requirements concerning their products and any use of Diodes Incorporated products in such safety-critical, life support devices or systems, notwithstanding any devices- or systems-related information or support that may be provided by Diodes Incorporated. Further, Customers must fully indemnify Diodes Incorporated and its representatives against any damages arising out of the use of Diodes Incorporated products in such safety-critical, life support devices or systems.

Copyright © 2018, Diodes Incorporated

www.diodes.com

Looking for pricing, stock, or lifecycle information?

Click below to explore more details on WIN SOURCE:

-  [View AP8800SG-13 on WIN SOURCE](#)
-  [Diodes Incorporated Information](#)

Optimize Your Supply Chain with WIN SOURCE Solutions

-  Global Sourcing Solution
-  Obsolete Management
-  Cost Control Management
-  Shortage Management
-  Alternative Solution
-  Excess Inventory Management