

Description

The AP8800A is a step-down DC/DC converter designed to drive LEDs with a constant current. The device can drive up to 7 LEDs, depending on the forward voltage of the LEDs, in series from a voltage source of 8V to 28V. Series connection of the LEDs provides identical LED currents resulting in uniform brightness and eliminating the requirement for ballast resistors. The AP8800A switches at frequency up to 600kHz. This allows the use of small size external components, hence minimizing the needed PCB area.

Maximum output current of AP8800A is set via an external resistor connected between the V_{IN} and SET input pins. Dimming is achieved by applying either a DC voltage or a PWM signal at the CTRL input pin. An input voltage of 0.2V or lower at CTRL switches off the output MOSFET simplifying PWM dimming.

Features

- LED Driving Current up to 370mA
- Better than 5% Accuracy
- High Efficiency up to 95%
- Operating Input Voltage from 8V to 28V
- Simple, Versatile Solution Requiring only 4 Components
- PWM/DC Input For Dimming Control
- Built-In Output Open-Circuit Protection
- TSOT25: Available in "Green" Molding Compound (No Br, Sb) with Lead Free Finish/ RoHS Compliant
- **Totally Lead-Free & Fully RoHS Compliant (Notes 1 & 2)**
- **Halogen and Antimony Free. "Green" Device (Note 3)**

Notes:

1. No purposely added lead. Fully EU Directive 2002/95/EC (RoHS), 2011/65/EU (RoHS 2) & 2015/863/EU (RoHS 3) compliant.
2. See <https://www.diodes.com/quality/lead-free/> for more information about Diodes Incorporated's definitions of Halogen- and Antimony-free, "Green" and Lead-free.
3. Halogen and Antimony free "Green" products are defined as those which contain <900ppm bromine, <900ppm chlorine (<1500ppm total Br + Cl) and <1000ppm antimony compounds.

Pin Assignments

(Top View)

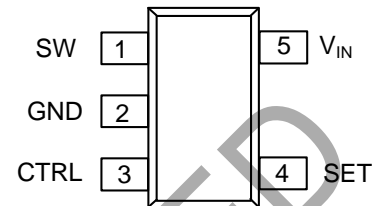

Applications

- MR16 Lamps
- General Illumination Lamps

Typical Applications Circuit

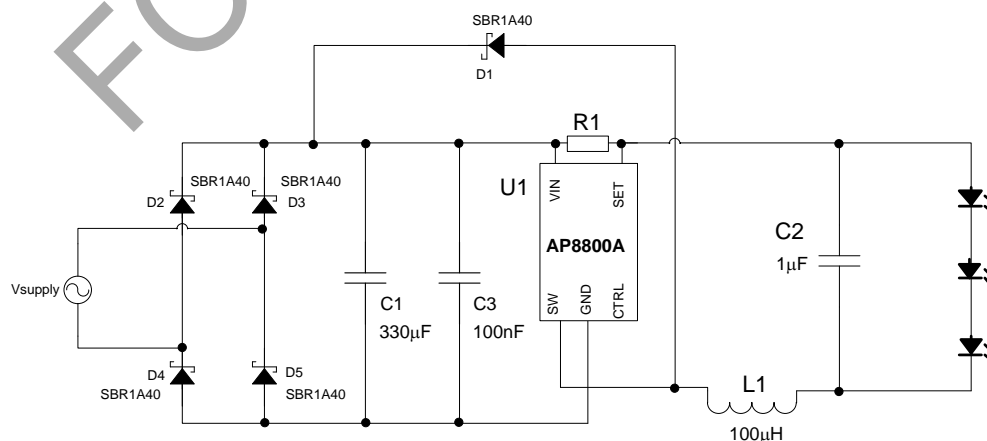

Pin Descriptions

Pin Name	Pin Number	Function
SW	1	Switch Pin. Connect inductor/freewheeling diode here, minimizing track length at this pin to reduce EMI.
GND	2	GND Pin
CTRL	3	Dimming and On/Off Control Input. <ul style="list-style-type: none"> Input voltage of 0.2V or lower forces the device into low current standby mode and shuts off the output. An open-drain/collector PWM signal allows the output current to be adjusted below the level set by the resistor connected to SET input pin. The input impedance is about 50kΩ, and if the pin is left open $V_{CTRL} = V_{REF}$. Drive with DC voltage ($0.3V < V_{CTRL} < 2.5V$) to adjust output current from 24% to 200% of I_{OUTnom}
SET	4	Set Nominal Output Current Pin. Configures the output current of the device.
V_{IN}	5	Input Supply Pin. Must be locally decoupled to GND with $\geq 2.2\mu F$ X7R ceramic capacitor – see applications section for more information.

Functional Block Diagram

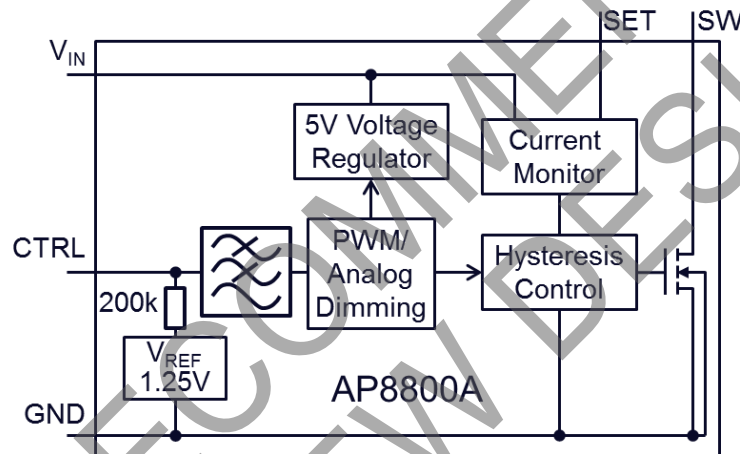

Absolute Maximum Ratings (@ $T_A = +25^\circ C$, unless otherwise specified.)

Symbol	Parameter	Ratings	Unit
V_{IN}	Continuous V_{IN} Pin Voltage Relative to GND	-0.3 to +30	V
V_{SET}	Set Voltage Relative to V_{IN}	$V_{IN} - 5$ to $V_{IN} + 0.3$	V
V_{SW}	SW Voltage Relative to GND	-0.3 to +30	V
V_{CTRL}	CTRL Pin Input Voltage	-0.3 to +5	V
I_{SW}	Switch Current	0.45	A
T_J	Junction Temperature	+105	$^\circ C$
T_{LEAD}	Lead Temperature Soldering	+300	$^\circ C$
T_{STG}	Storage Temperature Range	-55 to +150	$^\circ C$

Caution: Stresses greater than the 'Absolute Maximum Ratings' specified above, can cause permanent damage to the device. These are stress ratings only; functional operation of the device at these or any other conditions exceeding those indicated in this specification is not implied. Device reliability can be affected by exposure to absolute maximum rating conditions for extended periods of time.

Semiconductor devices are ESD sensitive and can be damaged by exposure to ESD events. Suitable ESD precautions should be taken when handling and transporting these devices.

Recommended Operating Conditions (@ $T_A = +25^\circ\text{C}$, unless otherwise specified.)

Symbol	Parameter	Min	Max	Unit
V_{IN}	Operating Input Voltage Relative to GND	8.0	28	V
V_{CTRLDC}	Voltage Range for 24% to 200% DC Dimming Relative to GND	0.3	2.5	V
V_{CTRLLL}	Voltage Low for PWM Dimming Relative to GND	—	0.2	V
I_{SW}	Continuous Average Switch Current (Note 4)	—	370	mA
$DPWM$	Duty Cycle Range Applied to CTRL ($f < 500\text{Hz}$)	0.01	1	—
f_{SW}	Switching Frequency	—	600	kHz
T_A	Ambient Temperature Range	-40	+105	$^\circ\text{C}$

Note: 4. Dependent on junction and ambient temperature.

Electrical Characteristics (@ $T_A = +25^\circ\text{C}$, $V_{IN} = 12\text{V}$, unless otherwise specified.)

Symbol	Parameter	Conditions	Min	Typ	Max	Unit
I_Q	Quiescent Current	$V_{CTRL} = 1.25\text{V}$, $f_{SW} = 250\text{kHz}$	—	300	650	μA
I_{SD}	Shutdown Current	$V_{CTRL} = 0\text{V}$	—	20	30	μA
V_{THD}	Internal Threshold Voltage	—	95	100	105	mV
V_{REF}	Internal Reference Voltage	—	—	1.25	—	V
I_{SET}	SET Pin Input Current	$V_{SET} = V_{IN} - 0.1$	—	1.3	—	μA
$R_{DS(ON)}$	On Resistance of MOSFET	—	—	1.5	2.2	Ω
I_{SW-LKG}	Switch Leakage Current	—	—	—	5	μA
f_{SW}	Switching Frequency with $L = 100\mu\text{H}$	ADJ pin floating $L = 100\text{H}$ $I_{OUT} = 350\text{mA}$ @ 1 LED ($V_{LED} = 3.4\text{V}$)	—	250	—	kHz
t_{SS}	Soft-Start Time	Time taken for output current to reach 90% of final value after $V_{CTRL} = 0.3\text{V}$	—	500	—	μs
t_{PD}	Internal Comparator Propagation Delay	—	—	55	—	ns
θ_{JA}	Thermal Resistance Junction-to-Ambient	TSOT25 (Note 5)	—	200	—	$^\circ\text{C/W}$

Note: 5. Test condition for TSOT25: Device mounted on FR-4 PCB (25mm x 25mm 1oz copper, minimum recommended pad layout on top layer and thermal vias to bottom layer ground plane. For better thermal performance, larger copper pad for heat-sink is needed.

Typical Characteristics

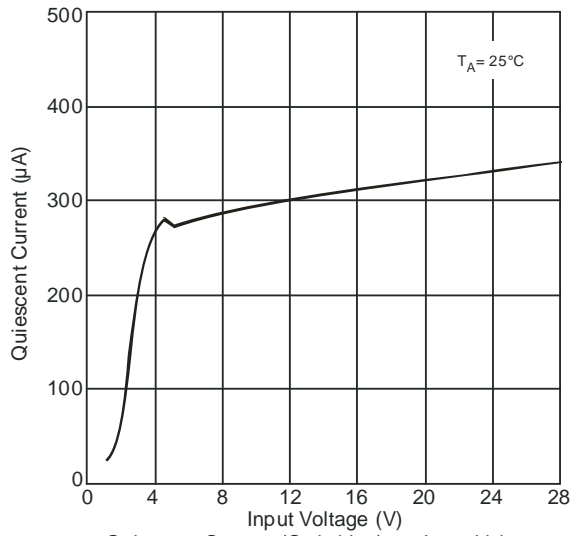

Quiescent Current (Switching) vs. Input Voltage

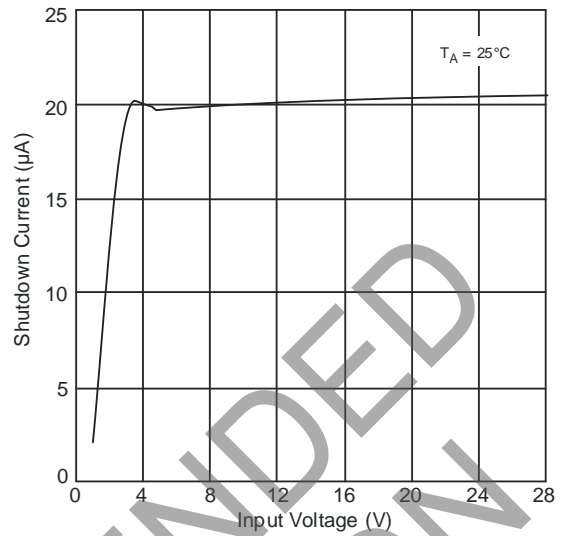

Shutdown Current (Non-Switching) vs. Input Voltage

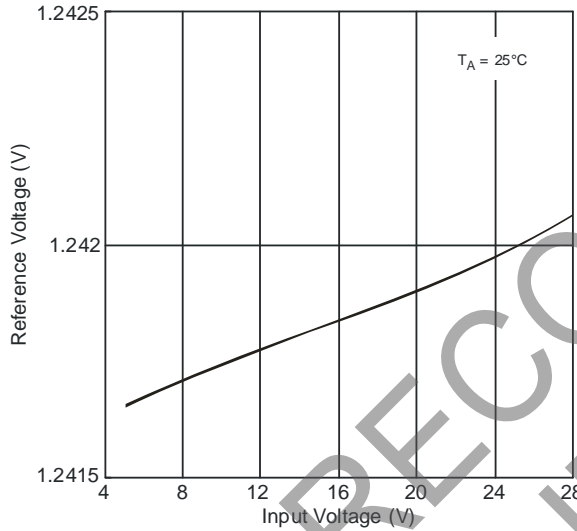

Reference Voltage vs. Input Voltage

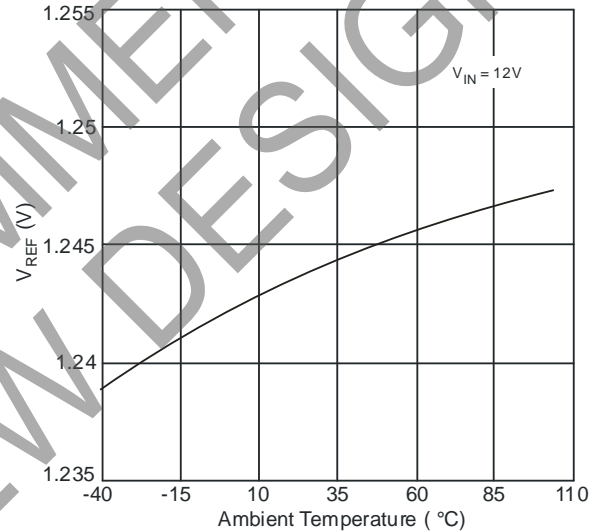

Reference Voltage vs. Ambient Temperature

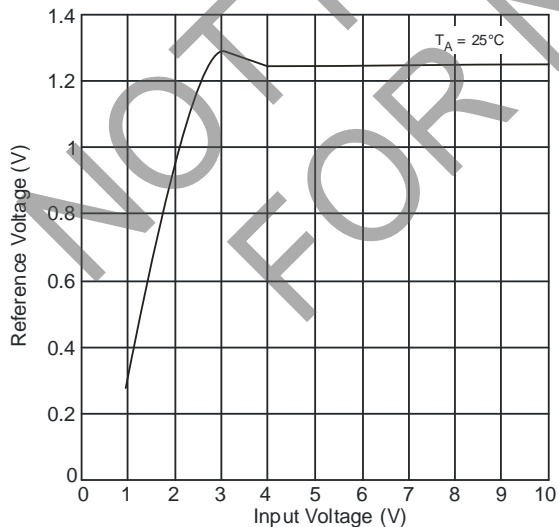

Reference Voltage vs. Input Voltage (Low Voltage)

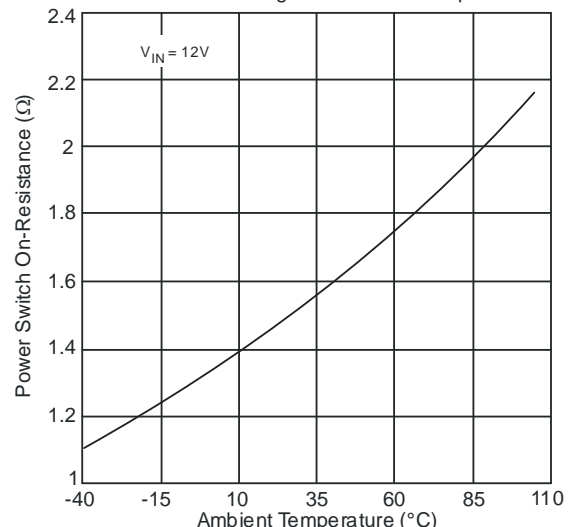

Power Switch On-Resistance vs. Ambient Temperature

Typical Characteristics (continued)

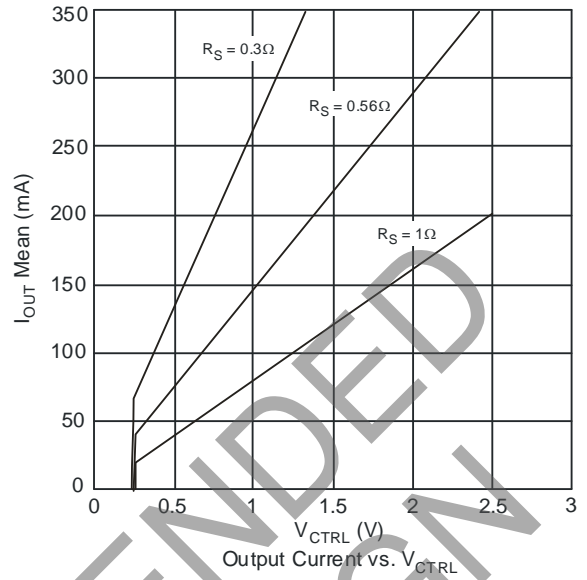
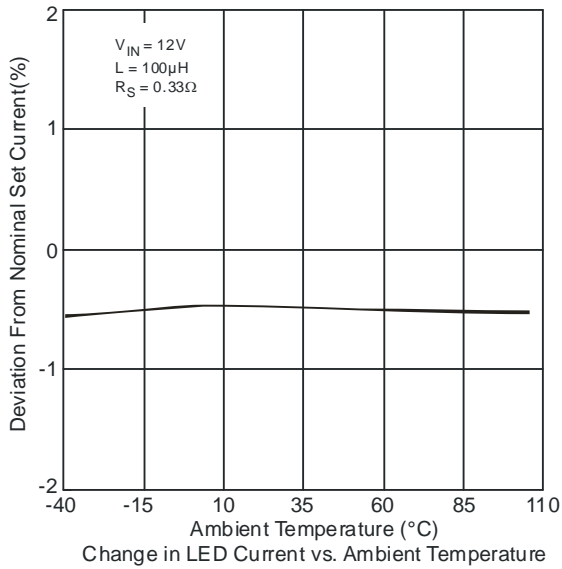

NOT RECOMMENDED FOR NEW DESIGN

Application Information (@T_A = +25°C, V_{IN} = 12V, unless otherwise specified.)

AP8800A Operation

The AP8800A is a hysteretic LED current switching regulator sometimes known as an equal ripple switching regulator. In normal operation, when voltage is applied at +V_{IN} (See Figure 1), the AP8800A internal switch is turned on. Current starts to flow through sense resistor R₁, inductor L1, and the LEDs. The current ramps up linearly, and the ramp rate is determined by the input voltage +V_{IN}, and the inductor L1 (See Figure 2).

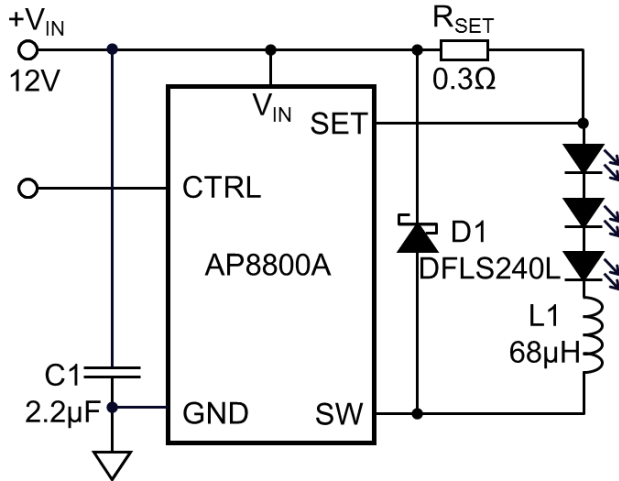

Figure 1 Typical Configuration

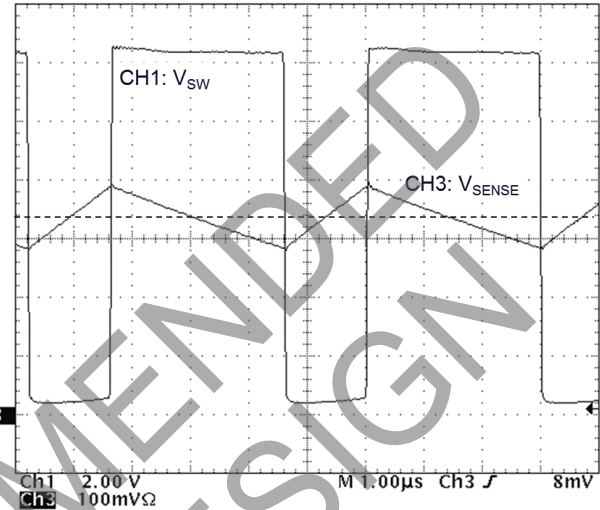

Figure 2 Typical Switching Waveform

This rising current produces a voltage ramp across R_{SET}. The internal circuit of the AP8800A senses the voltage across R_{SET} and applies a proportional voltage to the input of the internal comparator.

When this voltage reaches an internally set upper threshold, the internal switch is turned off. The inductor current continues to flow through R_{SET}, L1, the LEDs and the schottky diode D1, and back to the supply rail, but it decays, with the rate of decay determined by the forward voltage drop of the LEDs and the schottky diode.

This decaying current produces a falling voltage at R_{SET}, which is sensed by the AP8800A. A voltage proportional to the sense voltage across R_{SET} is applied at the input of the internal comparator. When this voltage falls to the internally set lower threshold, the internal switch is turned on again. This switch-on-and-off cycle continues to provide the average LED current set by the sense resistor R_{SET}, with a switching current determined by the input voltage and LED chain voltage.

In normal operation the off time is relatively constant (determined mainly by the LED chain voltage) with only the on-time varying as the input voltage changes. At duty cycles up to around 80% the ramp of the LED/switch current is very linear; however, as the duty cycle approaches 95% the LED current ramp starts to become more exponential. This has two effects:

1. The overall on time starts to increase lowering the overall switching frequency.
2. The average LED current starts to increase – which may impact accuracy.

LED Current Control

With the CTRL pin left floating and the external current sense resistor, R_{SET} (greater than 0.3 Ω) is connected between V_{IN} and SET, the nominal average output current in the LEDs is:

$$I_{LED} = \frac{V_{TH}}{R_{SET}} \quad \text{where } V_{TH} \text{ is nominally } 100\text{mV}$$

Application Information (continued) (@T_A = +25°C, V_{IN} = 12V, unless otherwise specified.)

Inductor Selection

A 68µH inductor or higher, is recommended for most AP8800A applications with input voltage at 12V.

Figure 3 displays the resulting switching frequency with various main circuit parameters: Supply voltage, Inductor value and number of LEDs to be driven.

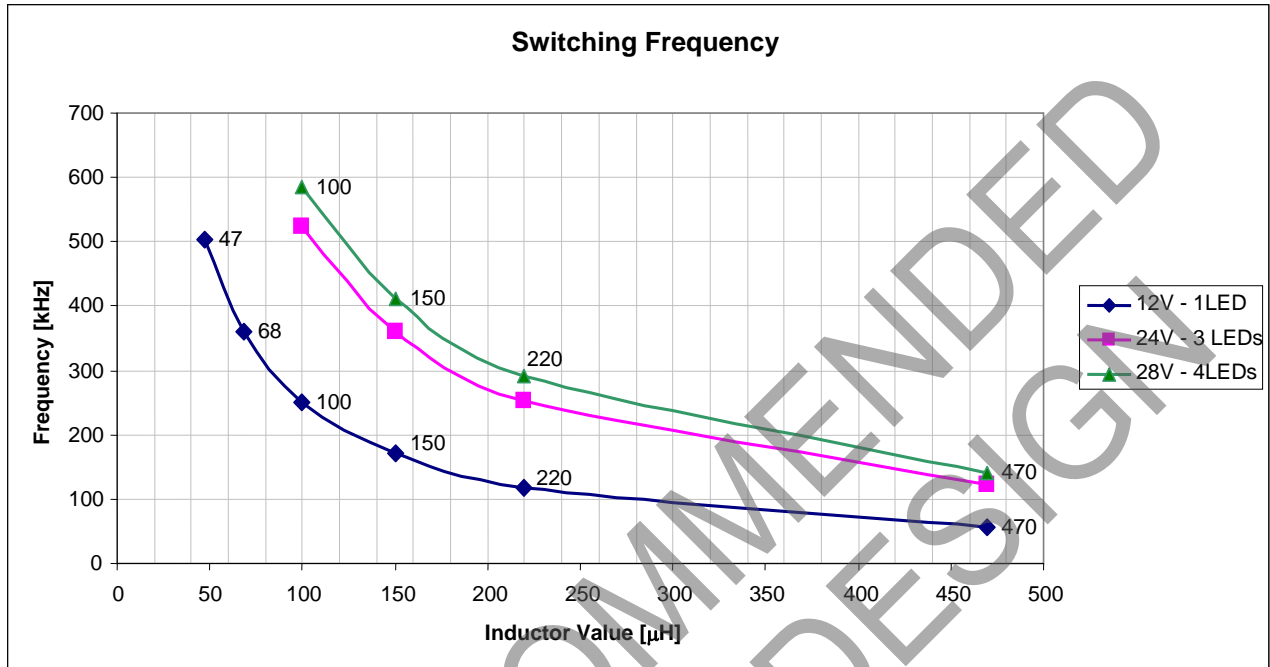

Figure 3 Switching Frequency vs. Supply Voltage, Inductor, and Number of LEDs

Capacitor Selection

A low ESR capacitor should be used for input decoupling, as the ESR of this capacitor appears in series with the supply source impedance and lowers overall efficiency. This capacitor has to supply the relatively high peak current to the coil and smooth the current ripple on the input supply. A minimum value of 1µF is acceptable if the DC input source is close to the device, but higher values will improve performance at lower input voltages, especially when the source impedance is high. The input capacitor should be placed as close as possible to the IC. For AC input sources a bigger capacitor (300µF in the case of 12C AC) to guarantee the accuracy of the LED current.

For maximum stability over temperature and voltage, capacitors with X7R, X5R, or better dielectric are recommended. Capacitors with Y5V dielectric are not suitable for decoupling in this application and should **NOT** be used.

Diode Selection

For maximum efficiency and performance, the rectifier (D1) should be a fast low capacitance SBR diode with low reverse leakage at the maximum operating voltage and temperature. The recommended diode for use with this part is the SBR1A40, with a current rating above the peak coil current and a continuous current rating higher than the maximum output load current. It is very important to consider the reverse leakage of the diode when operating above +85°C. Excess leakage will increase the power dissipation in the device.

Application Information (continued) (@T_A = +25°C, V_{IN} = 12V, unless otherwise specified.)

LED Current Dimming

The LED current can be dimmed in two ways;

1. Analog Dimming: Where a dc voltage is applied to the CTRL pin
or
2. PWM Dimming: Where a Pulse Width Modulated (PWM) signal is applied to the CTRL pin.

Analog Dimming

If the CTRL pin is driven by an external voltage (lower than 2.5V), the average LED current in this case is:

$$I_{LED} = \frac{V_{CTRL}}{V_{REF}} \times \frac{V_{TH}}{R_{SET}}$$

A DC signal from 0.3V to 2.5V applied to the CTRL pin will vary the LED current from 24% to 200% of nominal LED current. This provides an approximate 8:1 dimming range; it should be exercised when overdriving the CTRL pin to 200% of nominal LED current not to exceed the power dissipation of the package.

The graph in Figure 4 shows values of nominal average output current for 3 values of current setting resistor (R_{SET}) in the typical application circuit shown on Figure 1, for different voltages applied on the CTRL pin.

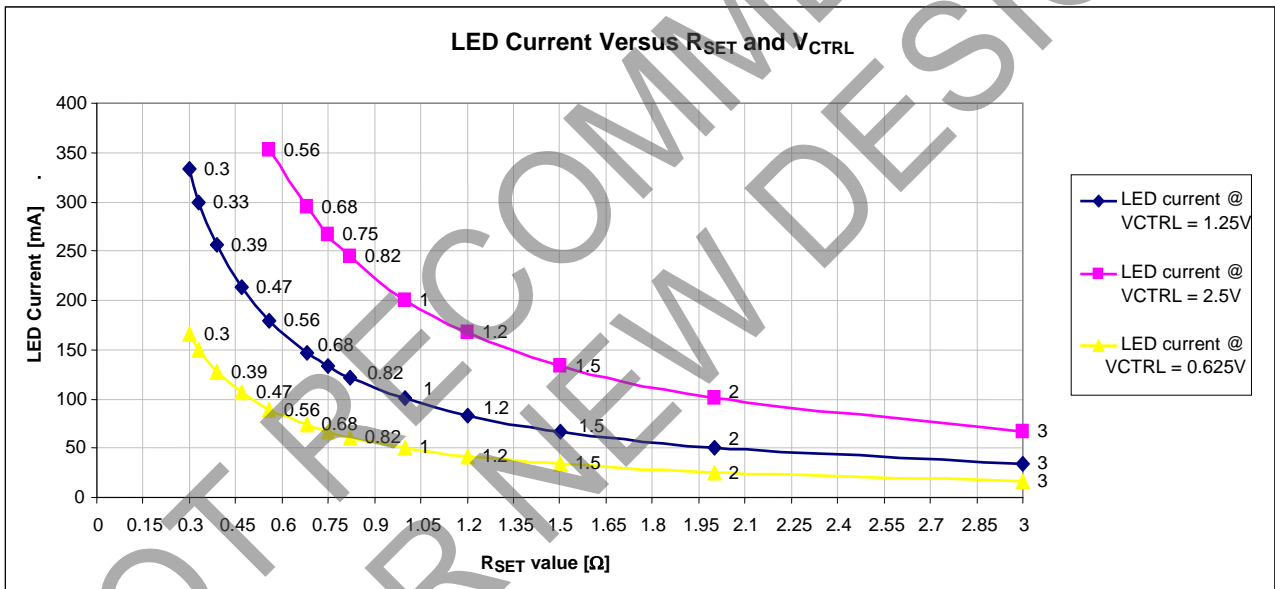

Figure 4 LED Current Setting vs. R_{SET} and V_{CTRL}

Application Information (continued) (@T_A = +25°C, V_{IN} = 12V, unless otherwise specified.)

PWM Dimming

A PWM signal with a max resolution of 8bit can be applied to CTRL pin, which regulates the output current to a value below the nominal average set by resistor R_{SET}. The PWM dimming gives a wider average LED current variation and is more accurate at lower average LED currents than by applying dc voltage to the CTRL pin to achieve average LED current dimming.

Figure 5 shows the typical PWM response of the AP8800A. An internal filter produces a ramp.

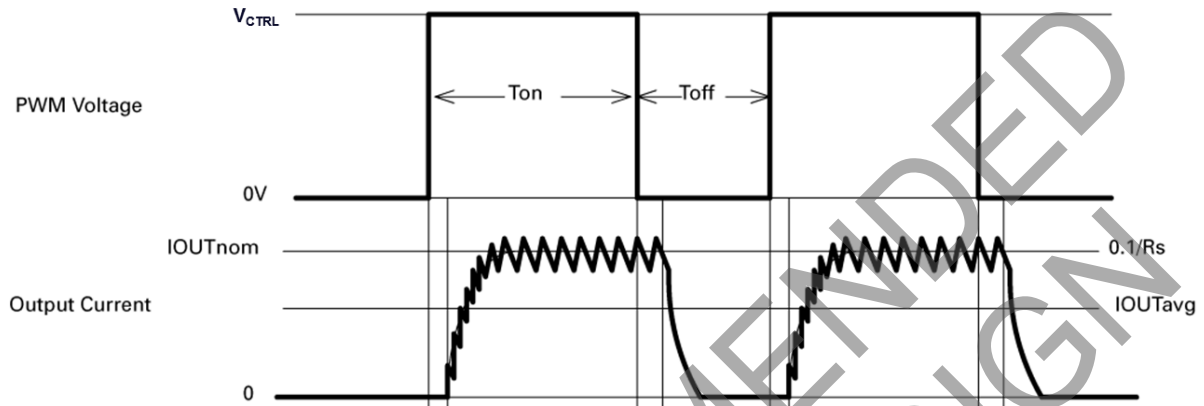

Figure 5 Typical PWM Dimming Waveform

The recommended method of driving the CTRL pin and controlling the amplitude of the PWM waveform is to use a small NPN switching transistor as shown below:

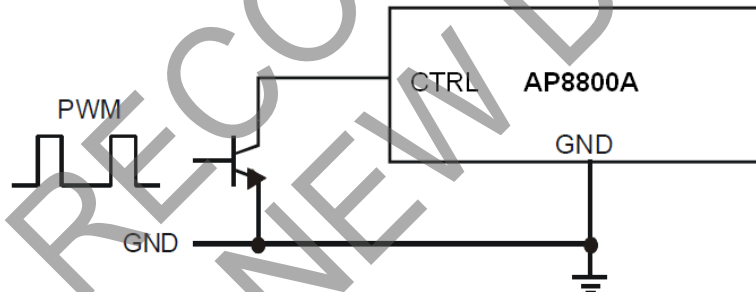

Figure 6 Open Collector PWM Dimming Circuit

This scheme uses the 200k resistor between the ADJ pin and the internal voltage reference as a pull-up resistor for the external transistor eg MMBT3904.

Soft-Start

An external capacitor from the CTRL pin to ground will provide soft-start delay, by increasing the time taken for the voltage on this pin to rise to the turn-on threshold and by slowing down the rate of rise of the control voltage at the input of the comparator.

The soft-start time is 0.5ms/nF.

Application Information (continued) (@T_A = +25°C, V_{IN} = 12V, unless otherwise specified.)

Fault Conditions

The AP8800A is inherently protected against open-LED conditions. If one LED becomes open circuit the device automatically stops switching and will only restart if the open-LED fault is removed.

If one or more LEDs should become shorted together then the switching frequency and duty cycle will change. If one or more LEDs get shorted together, the ramp-up time of LED current will become shorter due to there being a larger voltage across the inductor. However, the ramp-down time of the LED current will increase due to the voltage across the inductor becoming smaller.

Figure 7 below shows the AP8800A driving 3 LEDs when all 3 LEDs become shorted together. Due to the large voltage change across the inductor during both LED current ramp-up and ramp-down we see a large difference in switching frequency.

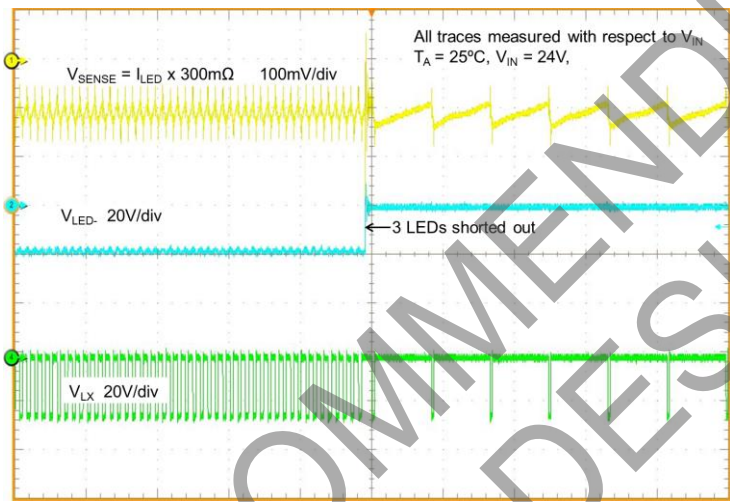

Figure 7 LED Short Fault Condition

Thermal Considerations

The graph below in Figure 8, gives details for the power derating of the AP8800AWT. This assumes the device to be mounted on a 25mm x 25mm PCB with 1oz copper standing in still air.

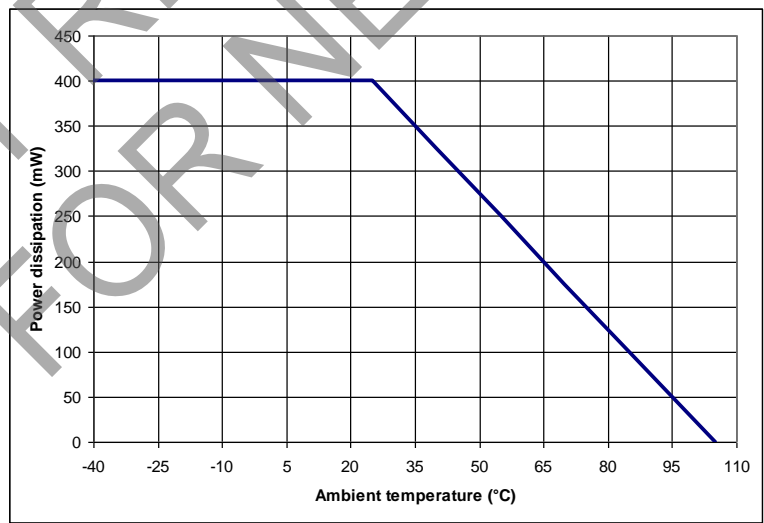
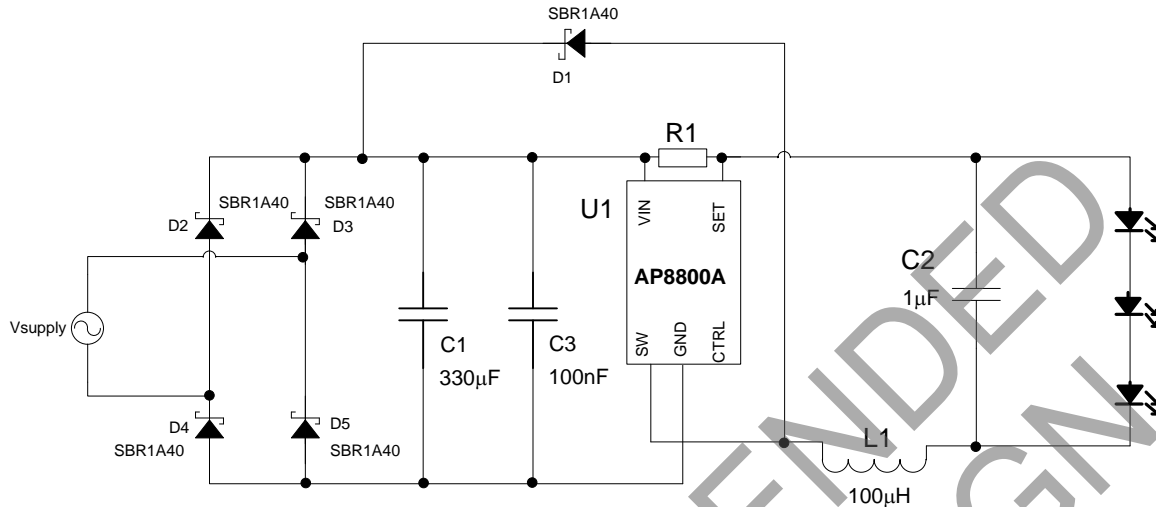

Figure 8 Derating Curve

Application Information (continued) (@T_A = +25°C, V_{IN} = 12V, unless otherwise specified.)

Application Example

The typical application for the AP8800A is the MR16 application driving 1W rated LEDs from a 12V supply.



AP8800A Component List

Quantity	PCB Ident	Value	Description	Suggested Source
1	U1	AP8800A	LED Driver IC	Diodes Incorporated
1	D1, D2, D3, D4, D5	SBR1A40	Input Bridge & Freewheeling Diode	Diodes Incorporated
1	R1	0R15	Resistor, 0805, +/-1% <+/-300ppm KOA SR732ATTDR150F	Kemet
1	C1	330µF (20V)	Electrolytic Capacitor	Kemet
1	C2	1µF > = 25V	X7R 1206 Generic Kemet C1206105K5RAC7800 (50V) NIC NMC1206X7R105K50F (50V)	Kemet Components NIC
1	C3	100nF > = 25V	X7R 0805 Generic Kemet C0805C104K5RAC (50V) NIC NMC0805X7R104K50TRPF (50V)	Kemet Kemet Components NIC
1	L1	100µH	LPS6235 - Series	Coilcraft

Ordering Information

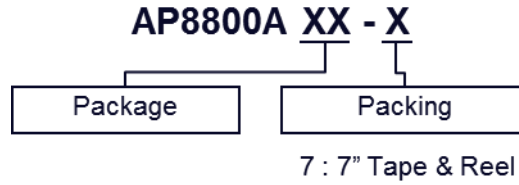

Part Number	Package Code	Packaging	7" Tape and Reel	
			Quantity	Part Number Suffix
AP8800AWT-7	WT	TSOT25	3000/Tape & Reel	-7

Marking Information

(1) TSOT25

(Top View)

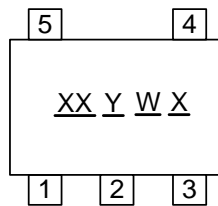

XX : Identification code
 Y : Year 0~9
 W : Week : A~Z : 1~26 week;
 a~z : 27~52 week; z represents
 52 and 53 week
 X : A~Z : Internal code

Part Number	Package	Identification Code
AP8800AWT-7	TSOT25	AZ

Package Outline Dimensions (All dimensions in mm.)

Please see <http://www.diodes.com/package-outlines.html> for the latest version.

TSOT25

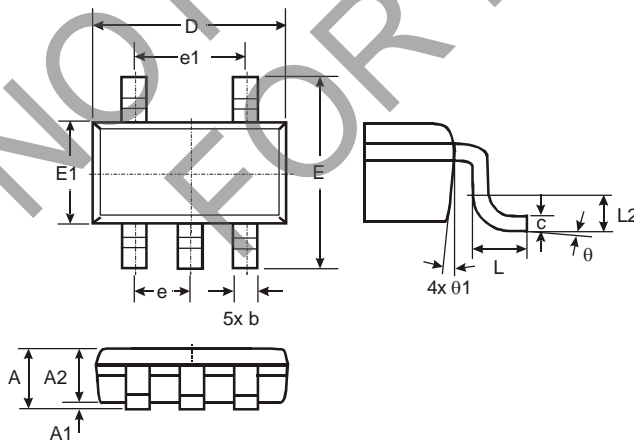

TSOT25			
Dim	Min	Max	Typ
A	-	1.00	-
A1	0.01	0.10	-
A2	0.84	0.90	-
D	-	-	2.90
E	-	-	2.80
E1	-	-	1.60
b	0.30	0.45	-
c	0.12	0.20	-
e	-	-	0.95
e1	-	-	1.90
L	0.30	0.50	-
L2	-	-	0.25
θ	0°	8°	4°
θ1	4°	12°	-
All Dimensions in mm			

Suggested Pad Layout

Please see <http://www.diodes.com/package-outlines.html> for the latest version.

TSOT25

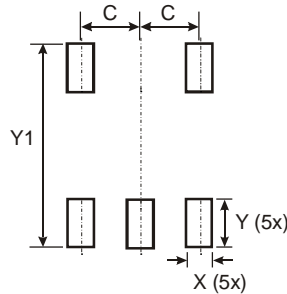

Dimensions	Value (in mm)
C	0.950
X	0.700
Y	1.000
Y1	3.199

IMPORTANT NOTICE

DIODES INCORPORATED MAKES NO WARRANTY OF ANY KIND, EXPRESS OR IMPLIED, WITH REGARDS TO THIS DOCUMENT, INCLUDING, BUT NOT LIMITED TO, THE IMPLIED WARRANTIES OF MERCHANTABILITY AND FITNESS FOR A PARTICULAR PURPOSE (AND THEIR EQUIVALENTS UNDER THE LAWS OF ANY JURISDICTION).

Diodes Incorporated and its subsidiaries reserve the right to make modifications, enhancements, improvements, corrections or other changes without further notice to this document and any product described herein. Diodes Incorporated does not assume any liability arising out of the application or use of this document or any product described herein; neither does Diodes Incorporated convey any license under its patent or trademark rights, nor the rights of others. Any Customer or user of this document or products described herein in such applications shall assume all risks of such use and will agree to hold Diodes Incorporated and all the companies whose products are represented on Diodes Incorporated website, harmless against all damages.

Diodes Incorporated does not warrant or accept any liability whatsoever in respect of any products purchased through unauthorized sales channel. Should Customers purchase or use Diodes Incorporated products for any unintended or unauthorized application, Customers shall indemnify and hold Diodes Incorporated and its representatives harmless against all claims, damages, expenses, and attorney fees arising out of, directly or indirectly, any claim of personal injury or death associated with such unintended or unauthorized application.

Products described herein may be covered by one or more United States, international or foreign patents pending. Product names and markings noted herein may also be covered by one or more United States, international or foreign trademarks.

This document is written in English but may be translated into multiple languages for reference. Only the English version of this document is the final and determinative format released by Diodes Incorporated.

LIFE SUPPORT

Diodes Incorporated products are specifically not authorized for use as critical components in life support devices or systems without the express written approval of the Chief Executive Officer of Diodes Incorporated. As used herein:

A. Life support devices or systems are devices or systems which:

1. are intended to implant into the body, or
2. support or sustain life and whose failure to perform when properly used in accordance with instructions for use provided in the labeling can be reasonably expected to result in significant injury to the user.

B. A critical component is any component in a life support device or system whose failure to perform can be reasonably expected to cause the failure of the life support device or to affect its safety or effectiveness.

Customers represent that they have all necessary expertise in the safety and regulatory ramifications of their life support devices or systems, and acknowledge and agree that they are solely responsible for all legal, regulatory and safety-related requirements concerning their products and any use of Diodes Incorporated products in such safety-critical, life support devices or systems, notwithstanding any devices- or systems-related information or support that may be provided by Diodes Incorporated. Further, Customers must fully indemnify Diodes Incorporated and its representatives against any damages arising out of the use of Diodes Incorporated products in such safety-critical, life support devices or systems.

Copyright © 2019, Diodes Incorporated

www.diodes.com

Looking for pricing, stock, or lifecycle information?

Click below to explore more details on WIN SOURCE:

- ⊖ [View AP8800AWT-7 on WIN SOURCE](#)
- ⊖ [Diodes Incorporated Information](#)

Optimize Your Supply Chain with WIN SOURCE Solutions

- ✓ Global Sourcing Solution
- ✓ Obsolete Management
- ✓ Cost Control Management
- ✓ Shortage Management
- ✓ Alternative Solution
- ✓ Excess Inventory Management