



**THE DATASHEET OF
AT17LV002-10SU**





AT17LV65⁽¹⁾, AT17LV128⁽¹⁾, AT17LV256, AT17LV512, AT17LV010, AT17LV002, AT17LV040

FPGA Configuration EEPROM Memory 3.3V and 5.0V System Support

DATASHEET

Note 1.
AT17LV65 and AT17LV128
are Not Recommended for
New Designs (NRND) and
are Replaced by AT17LV256.

Features

- EE Programmable Serial Memories Designed to Store Configuration Programs for Field Programmable Gate Arrays (FPGAs)
 - 65,536 x 1-bit⁽¹⁾
 - 131,072 x 1-bit⁽¹⁾
 - 262,144 x 1-bit
 - 524,288 x 1-bit
 - 1,048,576 x 1-bit
 - 2,097,152 x 1-bit
 - 4,194,304 x 1-bit
- Supports both 3.3V and 5.0V Operating Voltage Applications
- In-System Programmable (ISP) via 2-wire Bus
- Simple Interface to SRAM FPGAs
- Compatible with the Atmel[®] AT6000, AT40K and AT94K Devices, Altera[®] FLEX[®], APEX[™] Devices, ORCA[®], Xilinx[®] XC3000, XC4000, XC5200, Spartan[®], Virtex[®] FPGAs
- Cascadable Read-back to Support Additional Configurations or Higher-density Arrays
- Very Low-power CMOS EEPROM Process
- Programmable Reset Polarity
- Available in 6mm x 6mm x 1mm 8-lead LAP (Pin-compatible with 8-lead SOIC Package), 8-lead PDIP, 8-lead SOIC, 20-lead PLCC, 20-lead SOIC and 44-lead TQFP Packages
- Emulation of the Atmel AT24CXXX Serial EEPROMs
- Low-power Standby Mode
- High-reliability
 - Endurance: 100,000 Write Cycles
 - Data Retention: 90 Years for Industrial Parts (at 85°C)
- Green (Pb/Halide-free/RoHS Compliant) Package Options Available

Description

The AT17LV FPGA Configuration EEPROMs (Configurators) provide an easy-to-use, cost-effective configuration memory solution for Field Programmable Gate Arrays. The AT17LV devices are packaged in the 8-lead LAP, 8-lead PDIP, 8-lead SOIC, 20-lead PLCC, 20-lead SOIC and 44-lead TQFP options (Table 1). The AT17LV Configurators use a simple serial-access procedure to configure one or more FPGA devices. The user can select the polarity of the reset function during programming. These devices also support a write protection mechanism within its programming mode.

The AT17LV configurators can be programmed with industry-standard programmers, the Atmel ATDH2200E Programming Kit, or the Atmel ATDH2225 ISP Cable.

Table 1. AT17LV Packages

Package	AT17LV65/128/256 ⁽⁴⁾	AT17LV512/010	AT17LV002	AT17LV040
8-lead LAP	Yes	Yes	Yes	⁽³⁾
8-lead PDIP	Yes	Yes	—	—
8-lead SOIC	Yes	Use 8-lead LAP ⁽¹⁾	Use 8-lead LAP ⁽¹⁾	⁽³⁾
20-lead PLCC	Yes	Yes	Yes	—
20-lead SOIC	Yes ⁽²⁾	—	Yes ⁽²⁾	—
44-lead TQFP	—	—	Yes	Yes

- Notes:
1. The 8-lead LAP package has the same footprint as the 8-lead SOIC. Since an 8-lead SOIC package is not available for the AT17LV512/010/002 devices, it is possible to use an 8-lead LAP package instead.
 2. The pinout for the AT17LV65 (NRND), AT17LV128 (NRND), and AT17LV256 is not pin-for-pin compatible with the AT17LV512/010/002 devices.
 3. Refer to the AT17F datasheet which is available on the Atmel website.
 4. The AT17LV65 and AT17LV128 are not recommended for new designs (NRND).

1. Pin Configuration and Descriptions

Table 1-1. Pin Descriptions

Pin	Description
DATA	Three-state Data Output for Configuration. Open-collector bi-directional pin for programming.
CLK	Clock Input. Used to increment the internal address and bit counter for reading and programming.
WP1	Write Protect (1). Used to protect portions of memory during programming. Disabled by default due to internal pull-down resistor. This input pin is not used during FPGA loading operations. This pin is only available on AT17LV512/010/002 devices.
RESET/OE	RESET (Active Low) / Output Enable (Active High) when $\overline{\text{SER_EN}}$ is High. A Low level on RESET/OE resets both the address and bit counters. A High level (with CE Low) enables the data output driver. The logic polarity of this input is programmable as either RESET/OE or $\overline{\text{RESET/OE}}$. For most applications, RESET should be programmed active Low. This document describes the pin as $\overline{\text{RESET/OE}}$.
WP	Write Protect Input (when $\overline{\text{CE}}$ is Low) during programming only ($\overline{\text{SER_EN}}$ Low). When WP is Low, the entire memory can be written. When WP is enabled (High), the lowest block of the memory cannot be written. This pin is only available on the AT17LV65 (NRND), AT17LV128 (NRND), and the AT17LV256.
WP2	Write Protect (2). Used to protect portions of memory during programming. Disabled by default due to internal pull-down resistor. This input pin is not used during FPGA loading operations. This pin is only available on the AT17LV512/010.
$\overline{\text{CE}}$	Chip Enable Input (Active Low). A Low level (with OE High) allows CLK to increment the address counter and enables the data output driver. A High level on $\overline{\text{CE}}$ disables both the address and bit counters and forces the device into a low-power standby mode. <i>Note that this pin will not enable/disable the device in the Two-Wire Serial Programming mode ($\overline{\text{SER_EN}}$ Low).</i>
GND	Ground. A 0.2 μF decoupling capacitor between V_{CC} and GND is recommended.
CEO	Chip Enable Output (Active Low). This output goes Low when the address counter has reached its maximum value. In a daisy chain of AT17LV devices, the CEO pin of one device must be connected to the $\overline{\text{CE}}$ input of the next device in the chain. It will stay Low as long as $\overline{\text{CE}}$ is Low and OE is High. It will then follow CE until OE goes Low; thereafter, CEO will stay High until the entire EEPROM is read again. This CEO feature is not available on the AT17LV65 (NRND).
A2	Device Selection Input, A2. This is used to enable (or select) the device during programming (i.e., when $\overline{\text{SER_EN}}$ is Low). A2 has an internal pull-down resistor.
READY	Open Collector Reset State Indicator. Driven Low during power-up reset, released when power-up is complete. It is recommended to use a 4.7k Ω pull-up resistor when this pin is used.
$\overline{\text{SER_EN}}$	Serial Enable must be held High during FPGA loading operations. Bringing $\overline{\text{SER_EN}}$ Low enables the 2-wire Serial Programming Mode. For non-ISP applications, $\overline{\text{SER_EN}}$ should be tied to V_{CC} .
V_{CC}	Power Supply. 3.3V ($\pm 10\%$) and 5.0V ($\pm 10\%$) power supply pin.

Table 1-2. Pin Configurations

Name	I/O	AT17LV65/128/256 ⁽²⁾			AT17LV512/010		AT17LV002				AT17LV040
		8-lead DIP/LAP/ SOIC	20-lead PLCC	20-lead SOIC	8-lead DIP/ LAP	20-lead PLCC	8-lead LAP	20-lead PLCC	20-lead SOIC	44-lead TQFP	44-lead TQFP
DATA	I/O	1	2	2	1	2	1	2	1	40	40
CLK	I	2	4	4	2	4	2	4	3	43	43
WP1	I	–	–	–	–	5	–	5	–	7	–
$\overline{\text{RESET/OE}}$	I	3	6	6	3	6	3	6	8	13	13
WP2	I	–	–	–	–	7	–	7	–	–	–
$\overline{\text{CE}}$	I	4	8	8	4	8	4	8	10	15	15
GND		5	10	10	5	10	5	10	11	18	18
$\overline{\text{CEO}}^{(1)}$	O								13		
A2	I	6	14	14	6	14	6	14	–	21	21
READY	O	–	–	–	–	15	–	15	–	23	23
$\overline{\text{SER_EN}}$	I	7	17	17	7	17	7	17	18	35	35
V _{CC}		8	20	20	8	20	8	20	20	38	38

- Notes: 1. The $\overline{\text{CEO}}$ feature is not available on the AT17LV65 (NRND).
2. The AT17LV65 and AT17LV128 are not recommended for new designs.

Figure 1-1. Pinouts⁽¹⁾

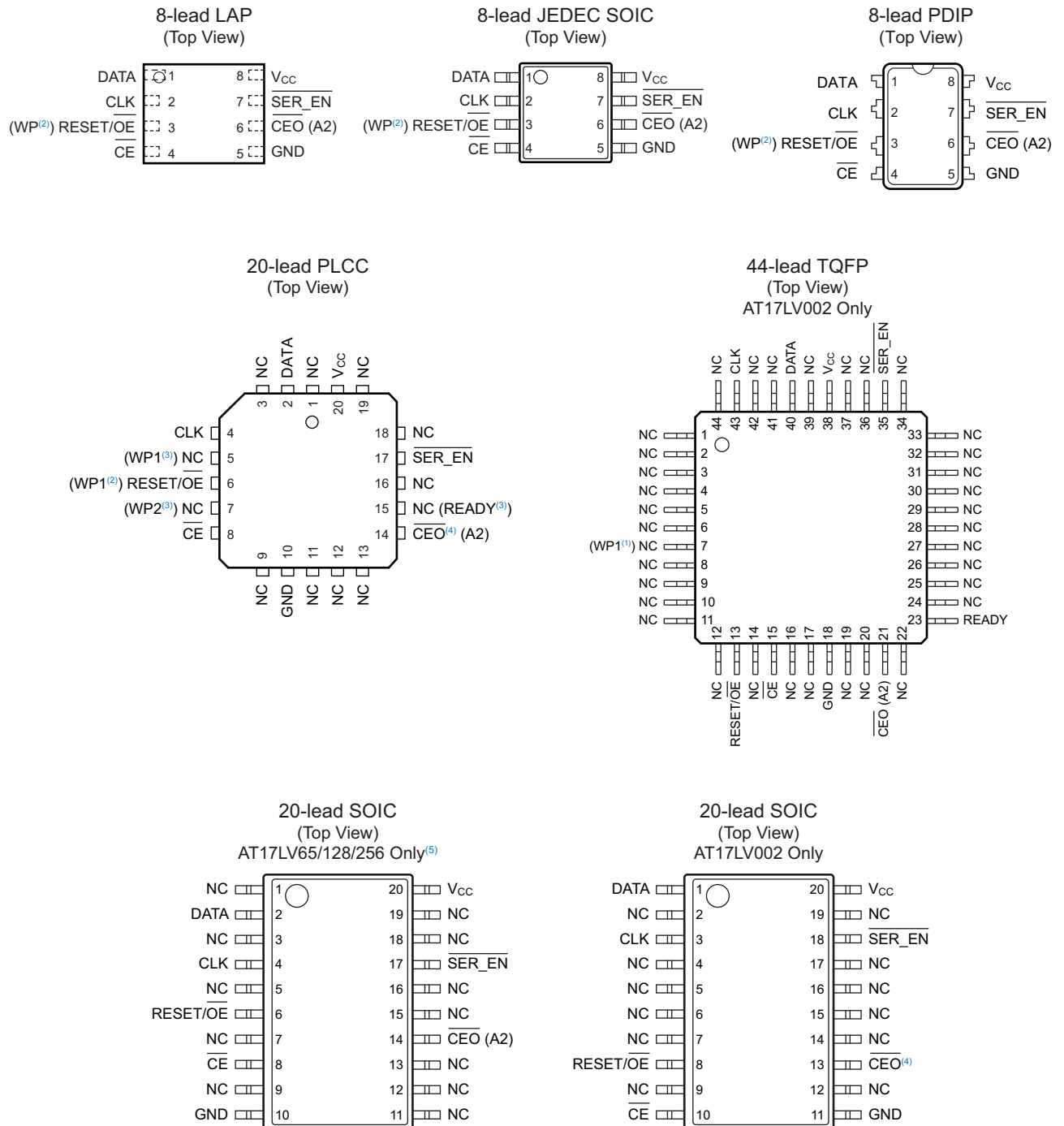

- Notes:
1. Drawings are not to scale.
 2. This pin is only available on the AT17LV65 (NRND), AT17LV128 (NRND), and AT17LV256.
 3. This pin is only available on the AT17LV512/010/002.
 4. This pin is not available on the AT17LV65 (NRND).
 5. The AT17LV65 and AT17LV128 are not recommended for new designs.

2. Block Diagram

Figure 2-1. Block Diagram

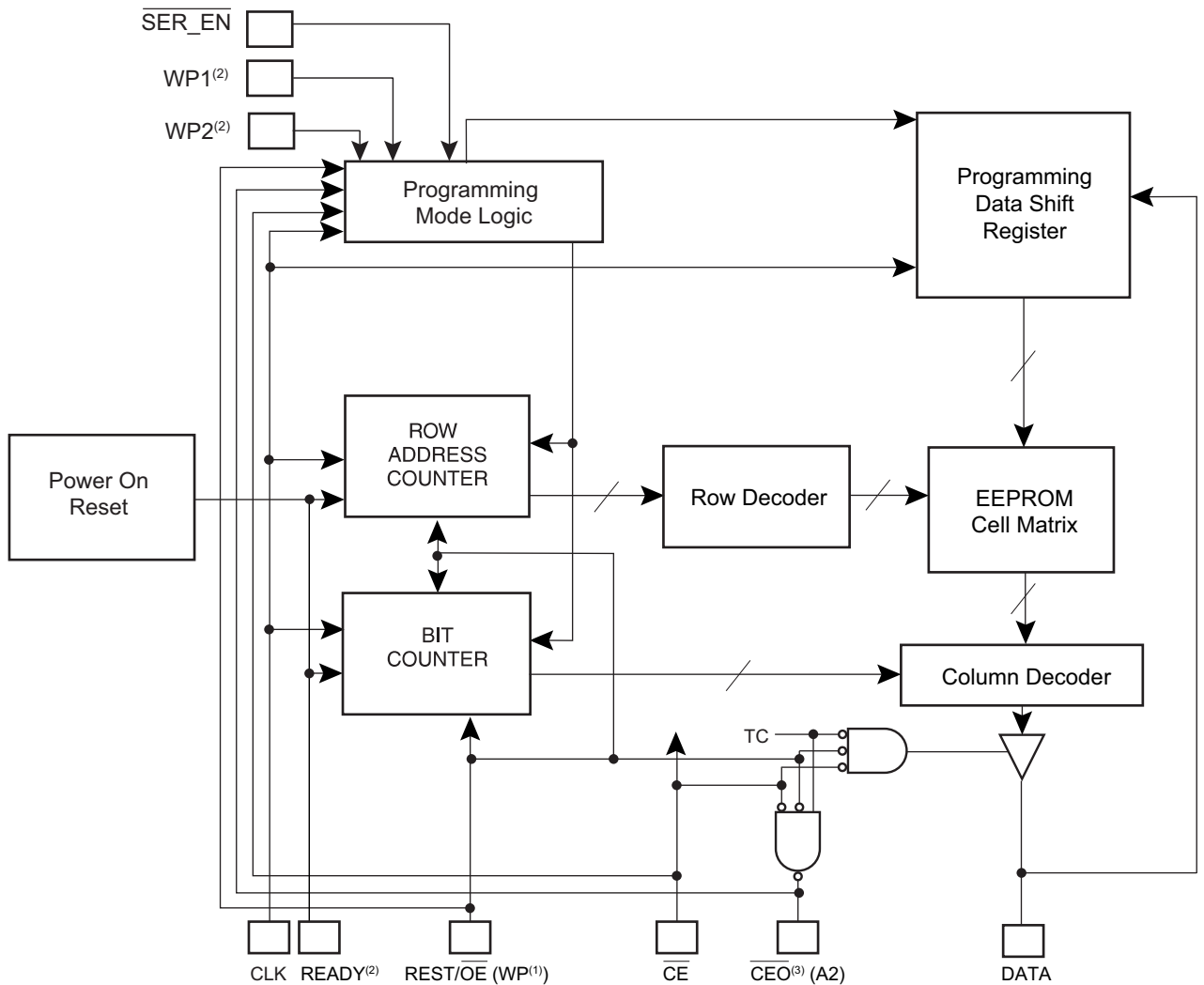

- Notes:
1. This pin is only available on the AT17LV65 (NRND), AT17LV128 (NRND), and AT17LV256.
 2. This pin is only available on AT17LV512, AT17LV010, and AT17LV002.
 3. The $\overline{\text{CEO}}$ feature is not available on the AT17LV65 (NRND).

3. Device Description

The control signals for the configuration EEPROM (\overline{CE} , $\overline{RESET/OE}$ and CCLK) interface directly with the FPGA device control signals. All FPGA devices can control the entire configuration process and retrieve data from the configuration EEPROM without requiring an external intelligent controller.

The configuration EEPROM $\overline{RESET/OE}$ and \overline{CE} pins control the tri-state buffer on the DATA output pin and enable the address counter. When $\overline{RESET/OE}$ is driven High, the configuration EEPROM resets its address counter and tri-states its DATA pin. The \overline{CE} pin also controls the output of the AT17LV configurator. If \overline{CE} is held High after the $\overline{RESET/OE}$ reset pulse, the counter is disabled and the DATA output pin is tri-stated. When \overline{OE} is subsequently driven Low, the counter and the DATA output pin are enabled. When $\overline{RESET/OE}$ is driven High again, the address counter is reset and the DATA output pin is tri-stated, regardless of the state of \overline{CE} .

When the configurator has driven out all of its data and \overline{CEO} is driven Low, the device tri-states the DATA pin to avoid contention with other configurators. Upon power-up, the address counter is automatically reset.

This is the default setting for the device. Since almost all FPGAs use RESET Low and OE High, this document will describe $\overline{RESET/OE}$.

4. FPGA Master Serial Mode Summary

The I/O and logic functions of any SRAM-based FPGA are established by a configuration program. The program is loaded either automatically upon power-up, or on command, depending on the state of the FPGA mode pins. In Master mode, the FPGA automatically loads the configuration program from an external memory. The AT17LV Serial Configuration EEPROM has been designed for compatibility with the Master Serial mode.

This document discusses the Atmel AT40K, AT40KAL and AT94KAL applications as well as Xilinx applications.

5. Control of Configuration

Most connections between the FPGA device and the AT17LV Serial EEPROM are simple and self-explanatory.

- The DATA output of the AT17LV configurator drives DIN of the FPGA devices.
- The master FPGA CCLK output drives the CLK input of the AT17LV configurator.
- The \overline{CEO} output of any AT17LV configurator drives the \overline{CE} input of the next configurator in a cascaded chain of EEPROMs.
- $\overline{SER_EN}$ must be connected to V_{CC} (except during ISP).
- The $\overline{READY}^{(1)}$ pin is available as an open-collector indicator of the device's reset status; it is driven Low while the device is in its power-on reset cycle and released (tri-stated) when the cycle is complete.

Note: 1. This pin is not available for the AT17LV65 (NRND), AT17LV128 (NRND), and AT17LV256.

6. Cascading Serial Configuration EEPROMs

For multiple FPGAs configured as a daisy-chain, or for FPGAs requiring larger configuration memories, cascaded configurators provide additional memory.

After the last bit from the first configurator is read, the clock signal to the configurator asserts its \overline{CEO} output Low and disables its DATA line driver. The second configurator recognizes the Low level on its \overline{CE} input and enables its DATA output.

After configuration is complete, the address counters of all cascaded configurators are reset if the $\overline{RESET/OE}$ on each configurator is driven to its active (Low) level.

If the address counters are not to be reset upon completion, then the $\overline{RESET/OE}$ input can be tied to its inactive (High) level.

The AT17LV65 (NRND) devices do not have the \overline{CEO} feature to perform cascaded configurations.

7. AT17LV Reset Polarity

The AT17LV configurator allows the user to program the reset polarity as either $\overline{RESET/OE}$ or $\overline{RESET/OE}$. This feature is supported by industry-standard programmer algorithms.

8. Programming Mode

The programming mode is entered by bringing $\overline{SER_EN}$ Low. In this mode the chip can be programmed by the 2-wire serial bus. The programming is done at V_{CC} supply only. Programming super voltages are generated inside the chip.

9. Standby Mode

The AT17LV configurators enter a low-power standby mode whenever \overline{CE} is asserted High. In this mode, the AT17LV65 (NRND), AT17LV128 (NRND), or the AT17LV256 configurator consumes less than 50 μ A of current at 3.3V (100 μ A for the AT17LV512/010 and 200 μ A for the AT17LV002/040). The output remains in a high-impedance state regardless of the state of the \overline{OE} input.

10. Electrical Specifications

10.1 Absolute Maximum Ratings*

Operating Temperature-40°C to +85°C
Storage Temperature-65°C to +150°C
Voltage on Any Pin with Respect to Ground-0.1V to $V_{CC} + 0.5V$
Supply Voltage (V_{CC}) -0.5V to +7.0V
Maximum Soldering Temp. (10s @ 1/16 in.) 260°C
ESD ($R_{ZAP} = 1.5K$, $C_{ZAP} = 100pF$) 2000V

*Notice: Stresses beyond those listed under Absolute Maximum Ratings may cause permanent damage to the device. This is a stress rating only and functional operation of the device at these or any other conditions beyond those listed under operating conditions is not implied. Exposure to Absolute Maximum Rating conditions for extended periods of time may affect device reliability.

10.2 Operating Conditions

Table 10-1. Operating Conditions

Symbol	Description	3.3V		5.0V		Units
		Min	Max	Min	Max	
V_{CC}	Industrial Supply voltage relative to GND -40°C to +85°C	3.0	3.6	4.5	5.5	V

10.3 DC Characteristics

Table 10-2. DC Characteristics for $V_{CC} = 3.3V \pm 10\%$

Symbol	Description	AT17LV65/128/256 ⁽¹⁾		AT17LV512/010		AT17LV002/40		Units
		Min	Max	Min	Max	Min	Max	
V_{IH}	High-level Input Voltage	2.0	V_{CC}	2.0	V_{CC}	2.0	V_{CC}	V
V_{IL}	Low-level Input Voltage	0	0.8	0	0.8	0	0.8	V
V_{OH}	High-level Output Voltage ($I_{OH} = -2mA$)	2.4		2.4		2.4		V
V_{OL}	Low-level Output Voltage ($I_{OL} = +3mA$)		0.4		0.4		0.4	V
I_{CCA}	Supply Current, Active Mode		5		5		5	mA
I_L	Input or Output Leakage Current ($V_{IN} = V_{CC}$ or GND)	-10	10	-10	10	-10	10	μA
I_{CCS}	Supply Current, Standby Mode		100		100		150	μA

Note: 1. The AT17LV65 and AT17LV128 are not recommended for new designs.

Table 10-3. DC Characteristics for $V_{CC} = 5.0V \pm 10\%$

Symbol	Description	AT17LV65/128/256 ⁽¹⁾		AT17LV512/010		AT17LV002/040		Units
		Min	Max	Min	Max	Min	Max	
V_{IH}	High-level Input Voltage	2.0	V_{CC}	2.0	V_{CC}	2.0	V_{CC}	V
V_{IL}	Low-level Input Voltage	0	0.8	0	0.8	0	0.8	V
V_{OH}	High-level Output Voltage ($I_{OH} = -2mA$)	3.60		3.76		3.76		V
V_{OL}	Low-level Output Voltage ($I_{OL} = +3mA$)		0.37		0.37		0.37	V
I_{CCA}	Supply Current, Active Mode		10		10		10	mA
I_L	Input or Output Leakage Current ($V_{IN} = V_{CC}$ or GND)	-10	10	-10	10	-10	10	μA
I_{CCS}	Supply Current, Standby Mode		150		200		350	μA

Note: 1. The AT17LV65 and AT17LV128 are not recommended for new designs.

10.4 AC Characteristics

Table 10-4. AC Characteristics for $V_{CC} = 3.3V \pm 10\%$

Symbol	Description	AT17LV65/128/256 ⁽³⁾		AT17LV512/010/002/040		Units
		Min	Max	Min	Max	
$T_{OE}^{(1)}$	OE to Data Delay		55		55	ns
$T_{CE}^{(1)}$	\overline{CE} to Data Delay		60		60	ns
$T_{CAC}^{(1)}$	CLK to Data Delay		80		60	ns
T_{OH}	Data Hold from \overline{CE} , OE, or CLK	0		0		ns
$T_{DF}^{(2)}$	\overline{CE} or OE to Data Float Delay		55		50	ns
T_{LC}	CLK Low Time	25		25		ns
T_{HC}	CLK High Time	25		25		ns
T_{SCE}	\overline{CE} Setup Time to CLK (to guarantee proper counting)	60		35		ns
T_{HCE}	\overline{CE} Hold Time from CLK (to guarantee proper counting)	0		0		ns
T_{HOE}	OE High Time (guarantees counter is reset)	25		25		ns
F_{MAX}	Maximum Clock Frequency		10		10	MHz

- Notes: 1. AC test lead = 50pF.
 2. Float delays are measured with 5pF AC loads. Transition is measured $\pm 200mV$ from steady-state active levels.
 3. The AT17LV65 and AT17LV128 are not recommended for new designs.

Table 10-5. AC Characteristics when Cascading for $V_{CC} = 3.3V \pm 10\%$

Symbol	Description	AT17LV65/128/256 ⁽³⁾		AT17LV512/010/002/040		Units
		Min	Max	Min	Max	
$T_{CDF}^{(2)}$	CLK to Data Float Delay		60		50	ns
$T_{OCK}^{(1)}$	CLK to \overline{CEO} Delay		60		55	ns
$T_{OCE}^{(1)}$	\overline{CE} to \overline{CEO} Delay		60		40	ns
$T_{OOE}^{(1)}$	$\overline{RESET/OE}$ to \overline{CEO} Delay		45		35	ns
F_{MAX}	Maximum Clock Frequency		8		10	MHz

- Notes: 1. AC test lead = 50pF.
2. Float delays are measured with 5pF AC loads. Transition is measured $\pm 200mV$ from steady-state active levels.
3. The AT17LV65 and AT17LV128 are not recommended for new designs.

Table 10-6. AC Characteristics for $V_{CC} = 5V \pm 10\%$

Symbol	Description	AT17LV65/128/256 ⁽³⁾		AT17LV512/010/002/040		Units
		Min	Max	Min	Max	
$T_{OE}^{(1)}$	OE to Data Delay		35		35	ns
$T_{CE}^{(1)}$	\overline{CE} to Data Delay		45		45	ns
$T_{CAC}^{(1)}$	CLK to Data Delay		55		50	ns
T_{OH}	Data Hold from \overline{CE} , OE, or CLK	0		0		ns
$T_{DF}^{(2)}$	\overline{CE} or OE to Data Float Delay		50		50	ns
T_{LC}	CLK Low Time	20		20		ns
T_{HC}	CLK High Time	20		20		ns
T_{SCE}	\overline{CE} Setup Time to CLK (To Guarantee Proper Counting)	40		25		ns
T_{HCE}	\overline{CE} Hold Time from CLK (To Guarantee Proper Counting)	0		0		ns
T_{HOE}	OE High Time (Guarantees Counter is Reset)	20		20		ns
F_{MAX}	Maximum Clock Frequency		12.5		15	MHz

- Notes: 1. AC test lead = 50pF.
2. Float delays are measured with 5pF AC loads. Transition is measured $\pm 200mV$ from steady-state active levels.
3. The AT17LV65 and AT17LV128 are not recommended for new designs.

Table 10-7. AC Characteristics When Cascading for $V_{CC} = 5V \pm 10\%$

Symbol	Description	AT17LV65/128/256 ⁽³⁾		AT17LV512/010/002/040		Units
		Min	Max	Min	Max	
$T_{CDF}^{(2)}$	CLK to Data Float Delay		50		50	ns
$T_{OCK}^{(1)}$	CLK to \overline{CEO} Delay		40		40	ns
$T_{OCE}^{(1)}$	\overline{CE} to \overline{CEO} Delay		35		35	ns
$T_{OOE}^{(1)}$	$\overline{RESET/OE}$ to \overline{CEO} Delay		35		30	ns
F_{MAX}	Maximum Clock Frequency		10		12.5	MHz

- Notes: 1. AC test lead = 50pF.
 2. Float delays are measured with 5pF AC loads. Transition is measured $\pm 200mV$ from steady-state active levels.
 3. The AT17LV65 and AT17LV128 are not recommended for new designs.

Figure 10-1. AC Waveforms

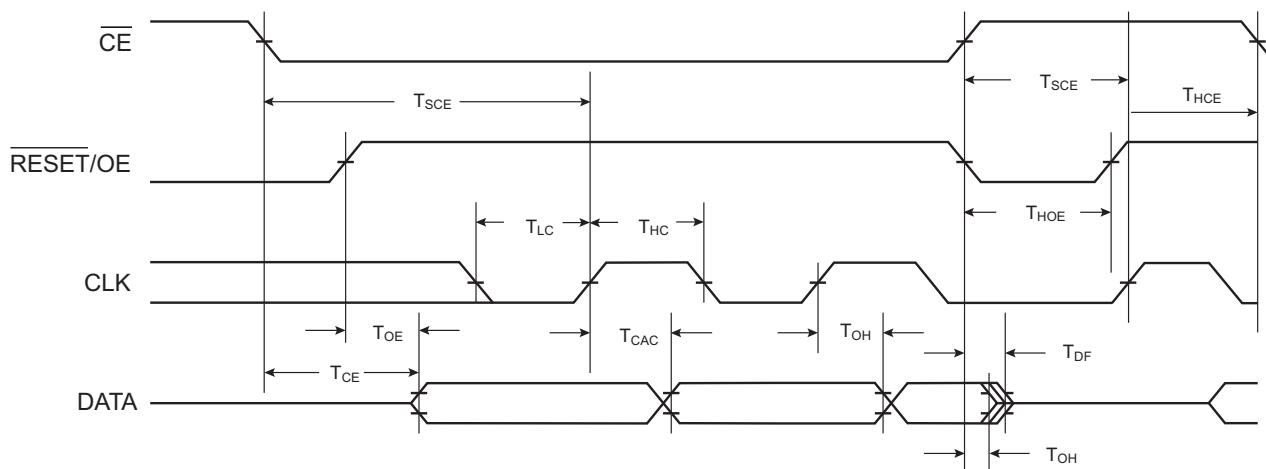
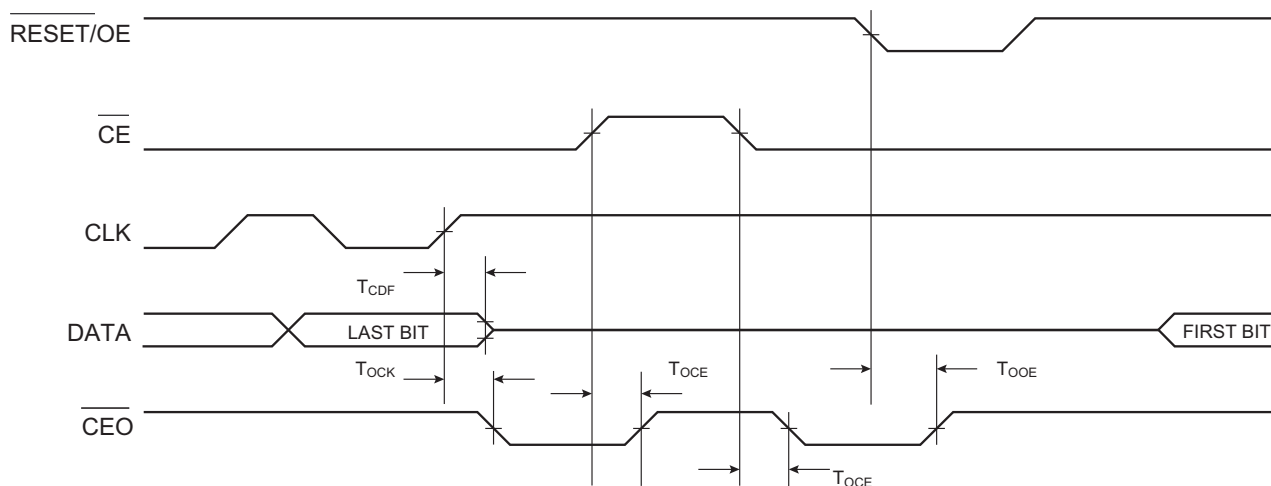

Figure 10-2. AC Waveforms when Cascading



10.5 Thermal Resistance Coefficients

Table 10-8. Thermal Resistance Coefficients

Package Type			AT17LV65/128/256 ⁽²⁾	AT17LV512/010	AT17LV002	AT17LV040
8CN4	Leadless Array Package (LAP)	θ_{JC} [°C/W]	45	45	45	—
		θ_{JA} [°C/W] ⁽¹⁾	115.71	135.71	159.60	—
8P3	Plastic Dual Inline Package (PDIP)	θ_{JC} [°C/W]	37	37	—	—
		θ_{JA} [°C/W] ⁽¹⁾	107	107	—	—
8S1	Plastic Gull Wing Small Outline (SOIC)	θ_{JC} [°C/W]	45	—	—	—
		θ_{JA} [°C/W] ⁽¹⁾	150	—	—	—
20J	Plastic Leaded Chip Carrier (PLCC)	θ_{JC} [°C/W]	35	35	35	—
		θ_{JA} [°C/W] ⁽¹⁾	90	90	90	—
20S2	Plastic Gull Wing Small Outline (SOIC)	θ_{JC} [°C/W]				—
		θ_{JA} [°C/W] ⁽¹⁾				—
44A	Thin Plastic Quad Flat Package (TQFP)	θ_{JC} [°C/W]	—	—	17	17
		θ_{JA} [°C/W] ⁽¹⁾	—	—	62	62

- Notes: 1. Airflow = 0ft/min.
 2. The AT17LV65 and AT17LV128 are not recommended for new designs.

11. Ordering Information

11.1 Ordering Code Detail

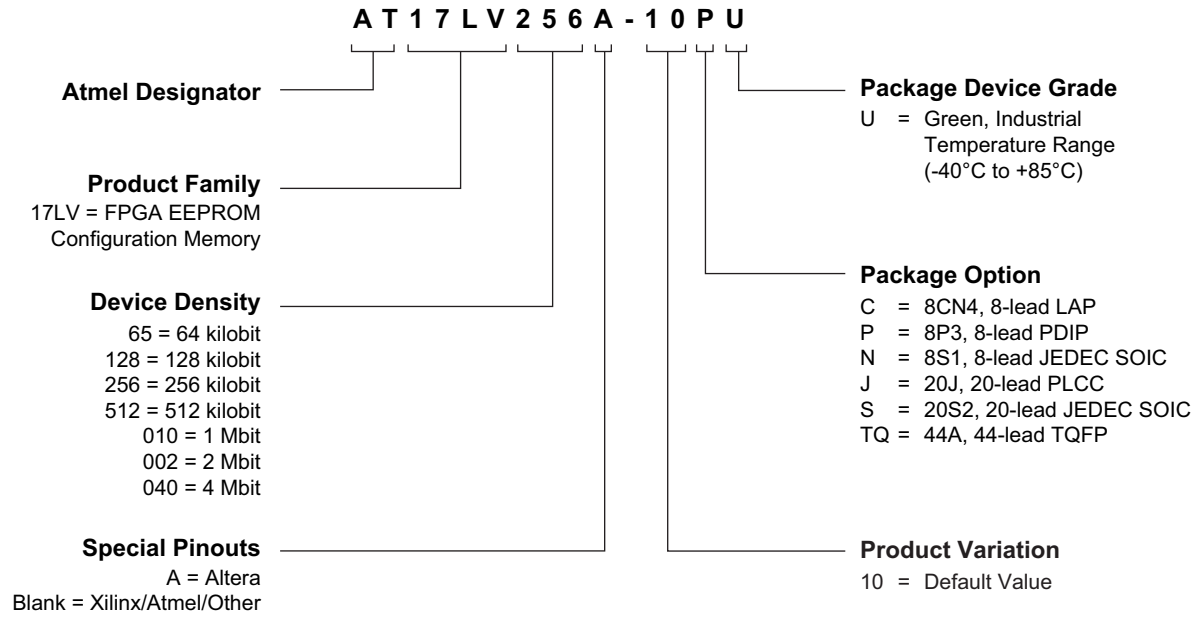

11.2 Ordering Information

Memory Size	Atmel Ordering Code	Lead Finish	Package	Voltage	Operation Range
256-Kbit	AT17LV256-10CU	CuNiAu (Lead-free/Halogen-free)	8CN4	3.0V to 5.5V	Industrial (-40°C to 85°C)
	AT17LV256-10JU	Sn (Lead-free/Halogen-free)	20J		
	AT17LV256-10NU		8S1		
	AT17LV256-10PU		8P3		
	AT17LV256-10SU		20S2		
512-Kbit	AT17LV512-10CU	CuNiAu (Lead-free/Halogen-free)	8CN4	3.0V to 5.5V	Industrial (-40°C to 85°C)
	AT17LV512-10JU	Sn (Lead-free/Halogen-free)	20J		
1-Mbit	AT17LV010-10CU	CuNiAu (Lead-free/Halogen-free)	8CN4	3.0V to 5.5V	Industrial (-40°C to 85°C)
	AT17LV010-10JU	Sn (Lead-free/Halogen-free)	20J		
	AT17LV010-10PU		8P3		
2-Mbit	AT17LV002-10CU	CuNiAu (Lead-free/Halogen-free)	8CN4	3.0V to 5.5V	Industrial (-40°C to 85°C)
	AT17LV002-10JU	Sn (Lead-free/Halogen-free)	20J		
	AT17LV002-10SU		20S2		
	AT17LV002-10TQU		44A		
4-Mbit	AT17LV040-10TQU	Sn (Lead-free/Halogen-free)	44A	3.0V to 5.5V	Industrial (-40°C to 85°C)

Package Type	
8CN4	8-lead, 6mm x 6mm x 1mm, Leadless Array Package (LAP) (Pin-compatible with 8-lead SOIC Packages)
8P3	8-lead, 0.300" Wide, Plastic Dual Inline Package (PDIP)
8S1	8-lead, 0.150" Wide, Plastic Gull Wing Small Outline (JEDEC SOIC)
20J	20-lead, Plastic J-leaded Chip Carrier (PLCC)
20S2	20-lead, 0.300" Wide, Plastic Gull Wing Small Outline (SOIC)
44A	44-lead, Thin (1.0mm) Plastic Quad Flat Package Carrier (TQFP)

12. Packaging Information

12.1 8CN4 – LAP

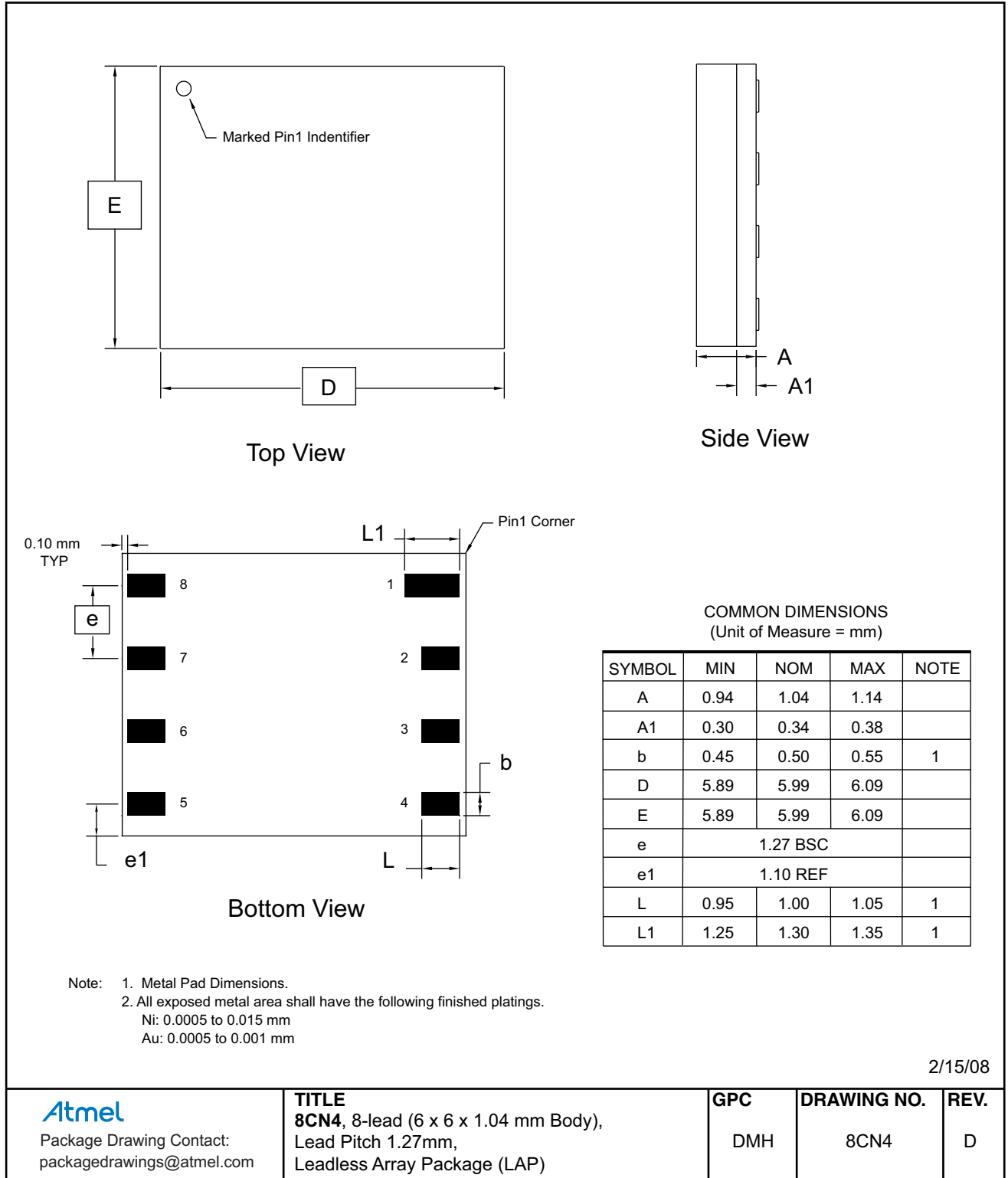

12.2 8P3 – PDIP

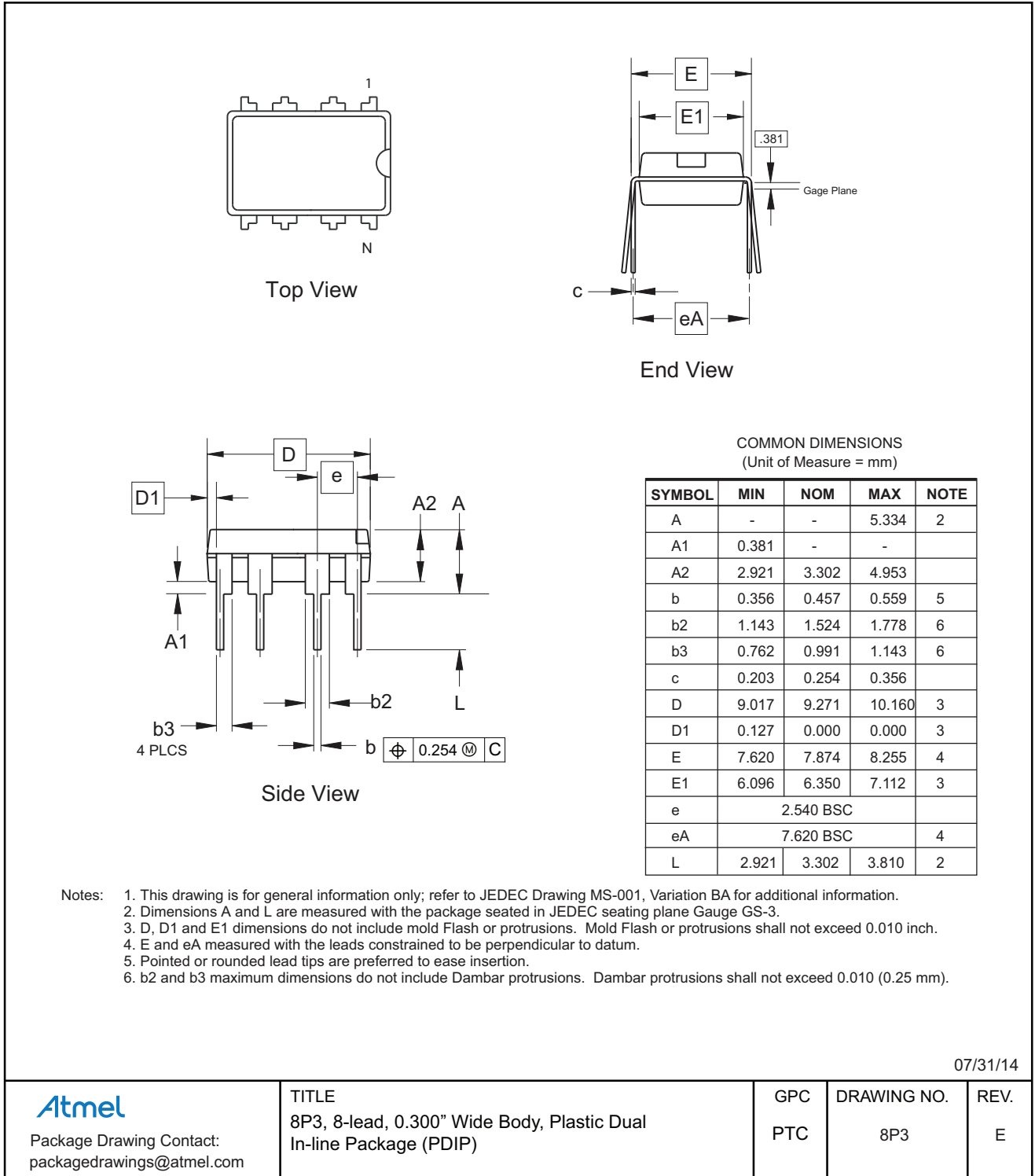

12.3 8S1 – SOIC

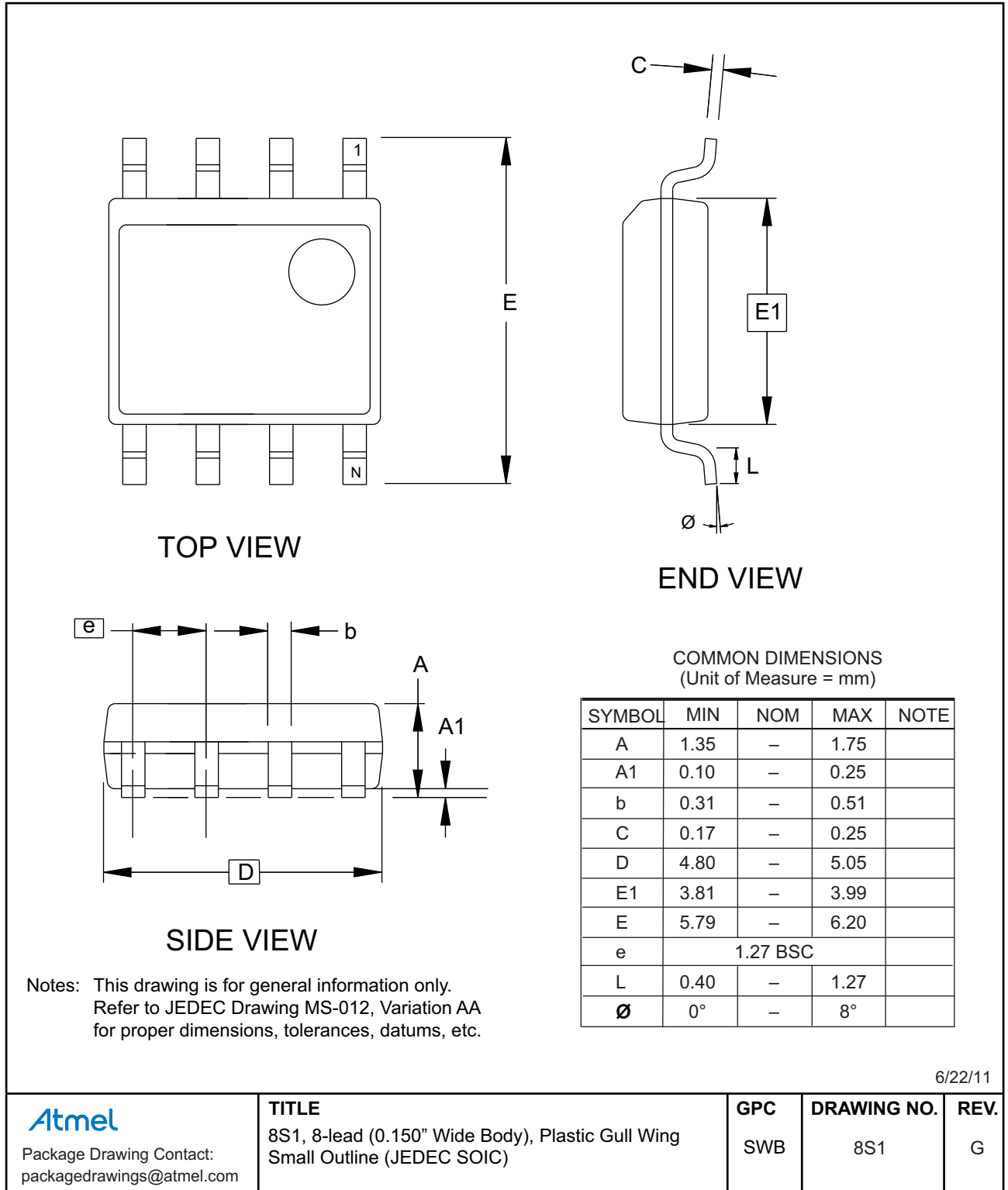

12.4 20J – PLCC

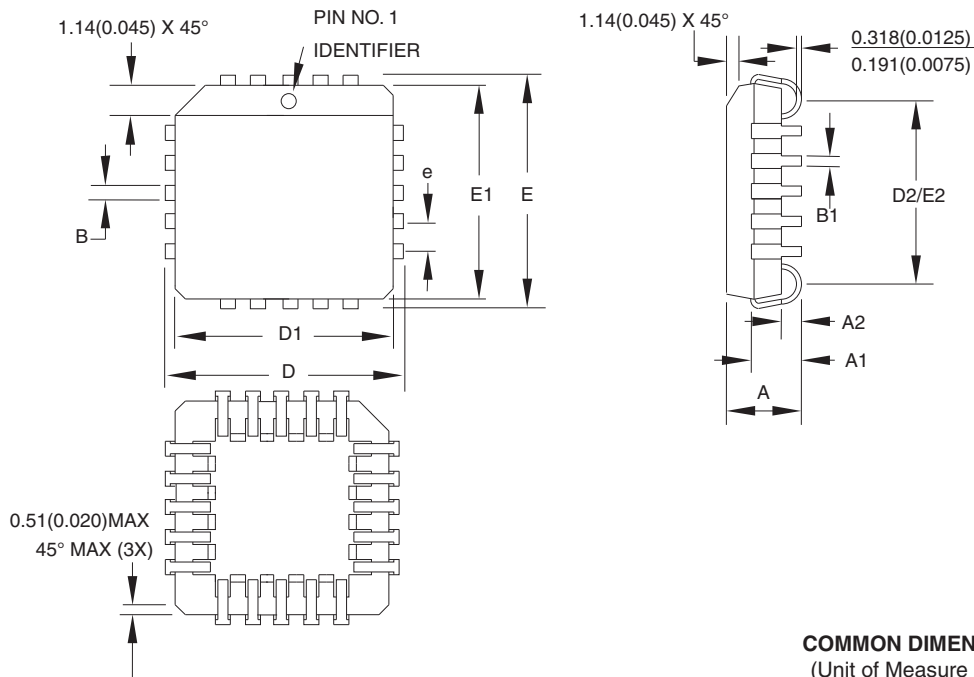

COMMON DIMENSIONS
(Unit of Measure = mm)

SYMBOL	MIN	NOM	MAX	NOTE
A	4.191	–	4.572	
A1	2.286	–	3.048	
A2	0.508	–	–	
D	9.779	–	10.033	
D1	8.890	–	9.042	Note 2
E	9.779	–	10.033	
E1	8.890	–	9.042	Note 2
D2/E2	7.366	–	8.382	
B	0.660	–	0.813	
B1	0.330	–	0.533	
e	1.270 TYP			

- Notes:
1. This package conforms to JEDEC reference MS-018, Variation AA
 2. Dimensions D1 and E1 do not include mold protrusion. Allowable protrusion is .010"(0.254mm) per side. Dimension D1 and E1 include mold mismatch and are measured at the extreme material condition at the upper or lower parting line.
 3. Lead coplanarity is 0.004" (0.102mm) maximum

10/04/01

Atmel

Package Drawing Contact:
packagedrawings@atmel.com

TITLE

20J, 20-lead, Plastic J-leaded Chip Carrier (PLCC)

DRAWING NO.

20J

REV.

B

12.5 20S2 – SOIC

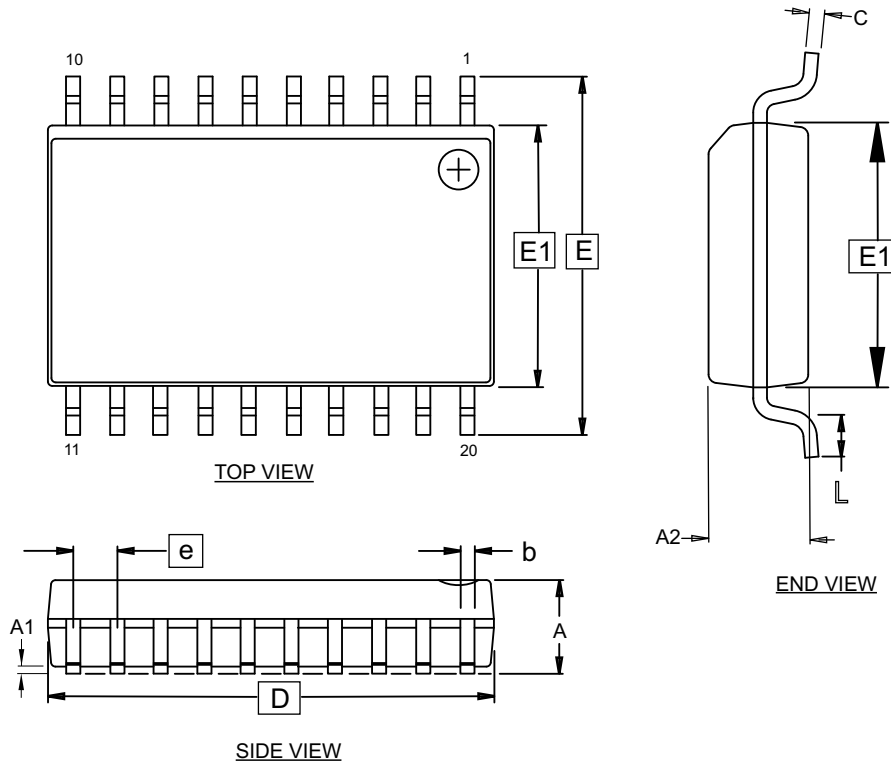

Notes:

1. This drawing is for general information only. Refer to JEDEC Drawing MS-013, Variation AC, for proper dimensions, tolerances, datums, etc.
2. Dimension D does not include mold flash, protrusions or gate burrs. Mold flash, protrusions or gate burrs shall not exceed 0.15 mm per end. Dimension E1 does not include interlead flash or protrusion. Interlead flash or protrusion shall not exceed 0.25 mm per side.
3. The package top may be smaller than the package bottom. Dimensions D and E1 are determined at the outermost extremes of the plastic body exclusive of mold flash, the burrs, gate burrs and interlead flash, but including any mismatch between the top and bottom of the plastic body.
4. The dimensions apply to the flat section of the lead between 0.10 to 0.25 mm from the lead tip.
5. Dimension 'b' does not include the dambar protrusion. Allowable dambar protrusion shall be 0.10 mm total in excess of the 'b' dimension at maximum material condition. The dambar may not be located on the lower radius of the foot.
6. 'A1' is defined as the vertical distance from the seating plane to the lowest point on the package body excluding the lid or thermal enhancement on the cavity down package configuration.

COMMON DIMENSIONS
(Unit of Measure = mm)

SYMBOL	MIN	NOM	MAX	NOTE
D		12.80 BSC		2,3
E1		7.50 BSC		2,3
E		10.30 BSC		
A	-	-	2.65	
A1	0.10	-	0.30	6
A2	2.05	-	-	
e		1.27 BSC		
b	0.31	-	0.51	4,5
L	0.40	-	1.27	
C	0.20	-	0.33	4

7/1/14

<p>Package Drawing Contact: packagedrawings@atmel.com</p>	TITLE	GPC	DRAWING NO.	REV.
	20S2, 20-lead, 0.300" Wide Body, Plastic Gull Wing Small Outline Package (SOIC)	SRJ	20S2	E

12.6 44A – TQFP

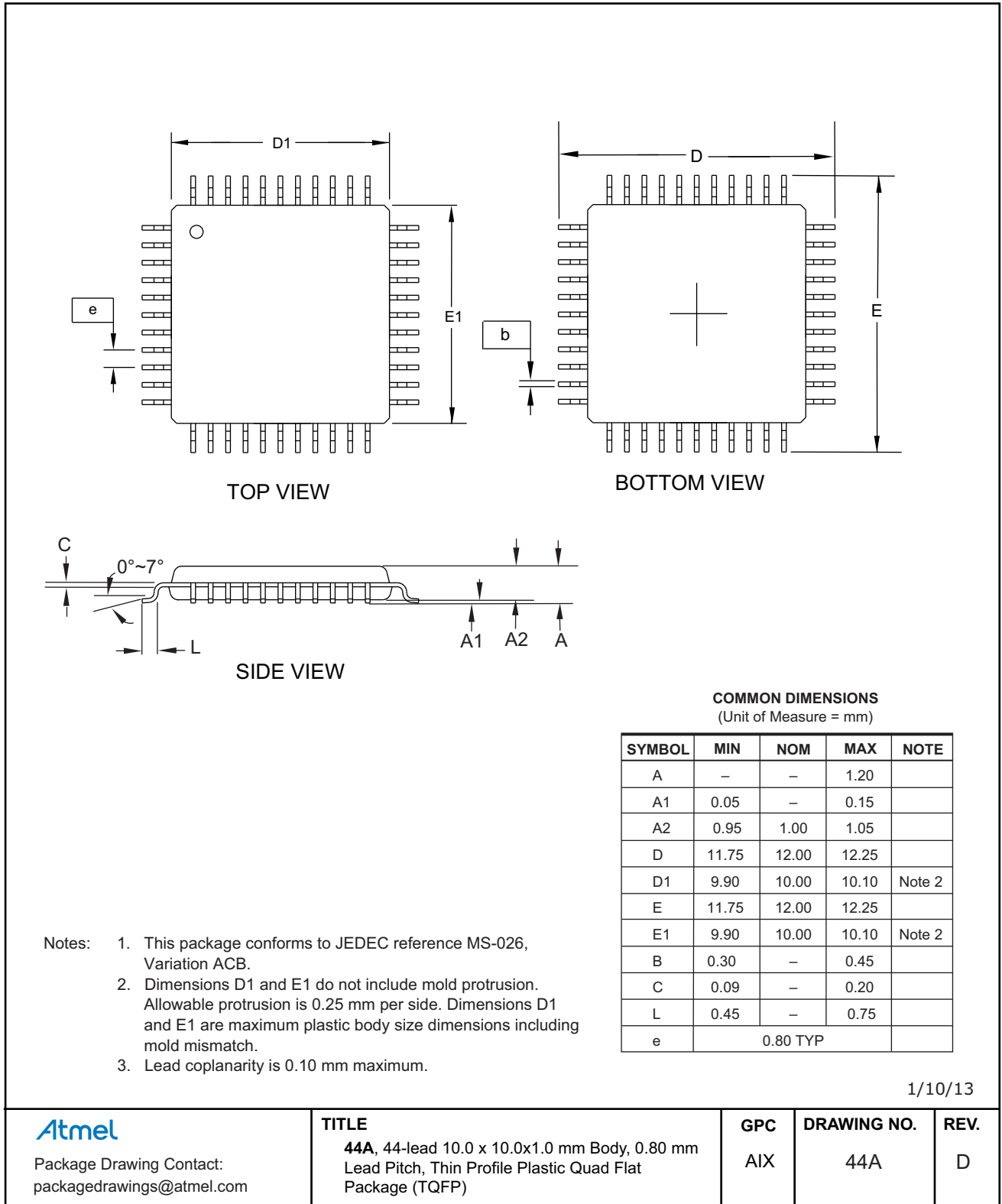

13. Revision History

Rev. No.	Date	History
2321J	10/2014	The AT17LV65 and AT17LV128 are not recommended for new designs. Removed the commercial options. Updated the 8P3, 8S1, 20S2, and 44A package outline drawings, ordering code details, ordering code table, document's template, Atmel logos, disclaimer page.
2321I	02/2008	Removed -10SC, 10SI, -10TQC, -10TQI, -10BJC and -10BJI devices from ordering information.
2321H	03/2006	Added last-time buy for AT17LVXXX-10CC and AT17LVXXX-10CI.

Looking for pricing, stock, or lifecycle information?

Click below to explore more details on WIN SOURCE:

- ⊖ [View AT17LV002-10SU on WIN SOURCE](#)
- ⊖ [Microchip Technology](#) Information

Optimize Your Supply Chain with WIN SOURCE Solutions

- ✓ Global Sourcing Solution
- ✓ Obsolete Management
- ✓ Cost Control Management
- ✓ Shortage Management
- ✓ Alternative Solution
- ✓ Excess Inventory Management