



**THE DATASHEET OF
ADS61JB23IRHAT**



12-Bit Input-Buffered 80 MSPS ADC with JESD204A Output Interface

Check for Samples: [ADS61JB23](#)

FEATURES

- **Output Interface:**
 - Single-Lane and Dual-Lane Interfaces
 - Maximum Data Rate of 1.6 Gbps
 - Meets JESD204A Specification
 - CML Outputs with Current Programmable from 2 mA – 32 mA
- **Power Dissipation:**
 - 440 mW at 80 MSPS in Single Lane Mode
 - Power Scales Down with Clock Rate
- **Input Interface: Buffered Analog Inputs**
- **71.7 dBFS SNR at 70 MHz IF**
- **Analog Input FSR: 2 Vpp**
- **External and Internal (trimmed) Reference Support**
- **1.8V Supply (Analog and digital), 3.3 V Supply for Input Buffer**
- **Programmable Digital Gain: 0dB – 6dB**
- **Straight Offset Binary or Twos Complement Output**
- **Package:**
 - 6 mm x 6 mm QFN-40

APPLICATIONS

- **Wireless Base-station Infrastructure**
- **Test and Measurement Instrumentation**

DESCRIPTION

The ADS61JB23 is a high-performance, low-power, single channel analog-to-digital converter with an integrated JESD204A output interface. Available in a 6 mm x 6 mm QFN package, with both single-lane and dual-lane output modes, the ADS61JB23 offers an unprecedented level of compactness. The output interface is compatible to the JESD204A standard, with an additional mode (as per IEEE Std 802.3-2002 part3, Clause 36.2.4.12) to interface seamlessly to the TI TLK family of SERDES transceivers. Equally impressive is the inclusion of an on-chip analog input buffer, providing isolation between the sample/hold switches and higher and more consistent input impedance.

The ADS61JB23 is specified over the industrial temperature range (–40°C to 85°C).



Please be aware that an important notice concerning availability, standard warranty, and use in critical applications of Texas Instruments semiconductor products and disclaimers thereto appears at the end of this data sheet.



These devices have limited built-in ESD protection. The leads should be shorted together or the device placed in conductive foam during storage or handling to prevent electrostatic damage to the MOS gates.

FUNCTIONAL BLOCK DIAGRAM

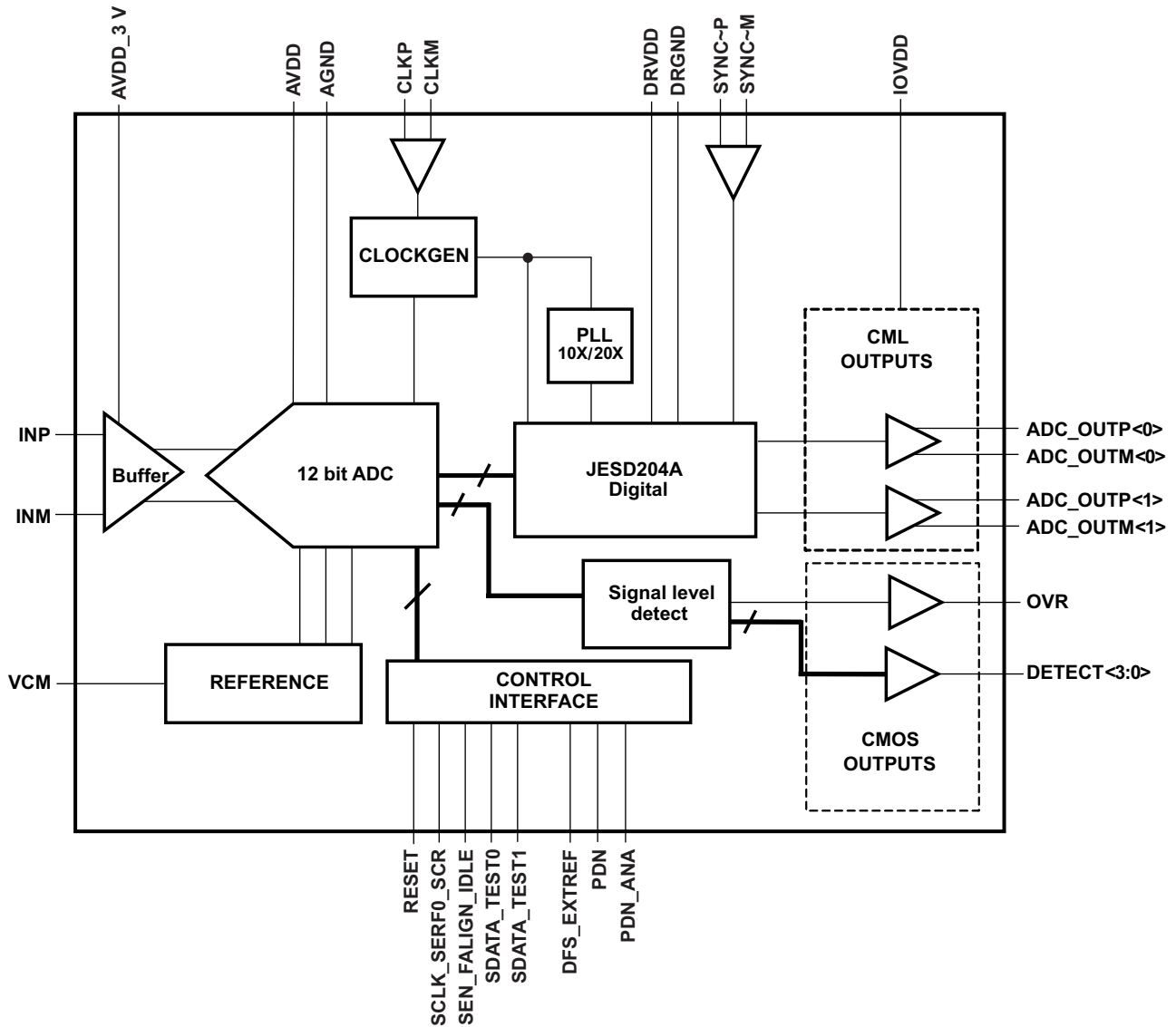

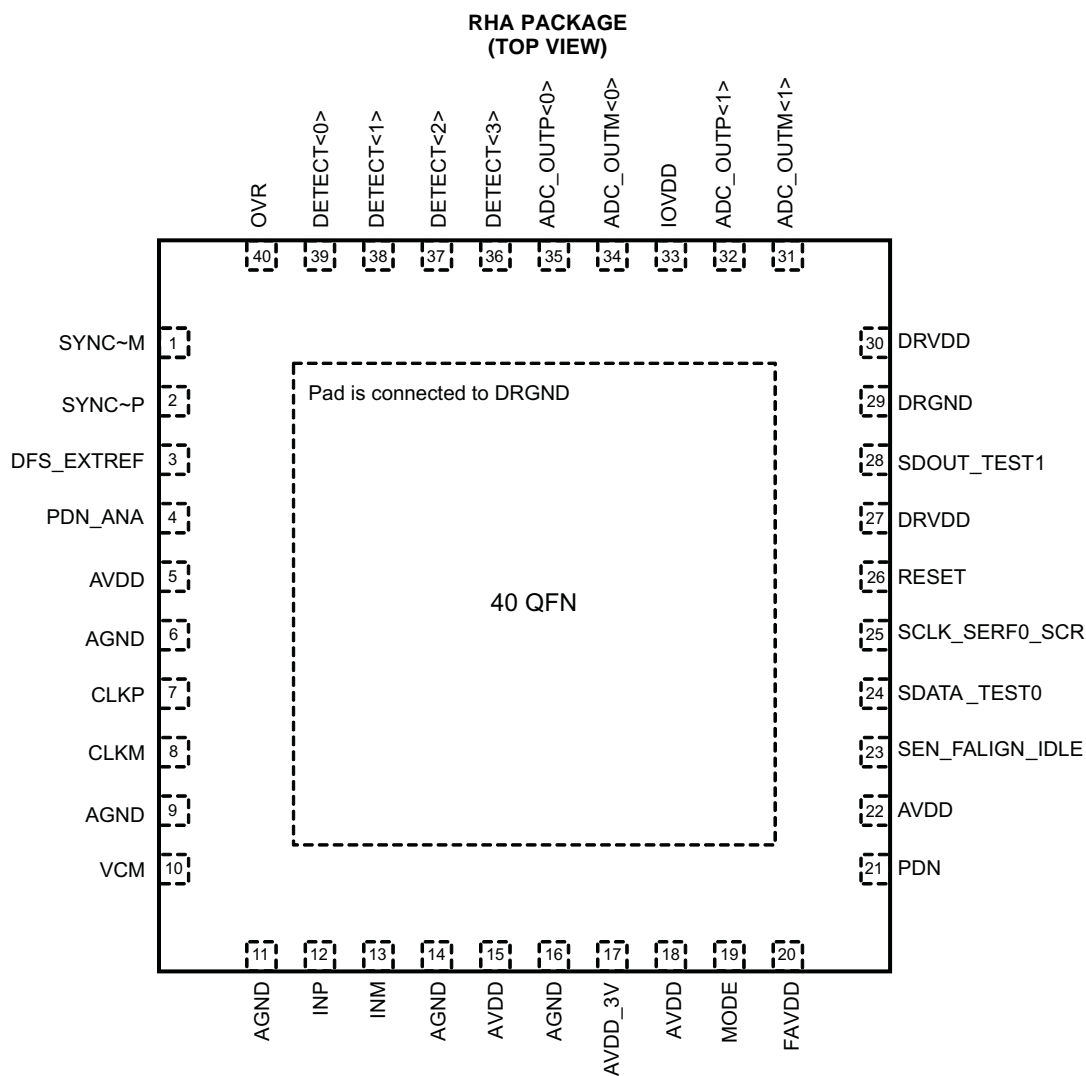

PIN FUNCTIONS

PIN		DESCRIPTION
NAME	NO.	
ADC_OUTM<1>	31	CML output Lane 2 – Negative output
ADC_OUTM<0>	34	CML output Lane 1 – Negative output
ADC_OUTP<1>	32	CML output Lane 2 – Positive output
ADC_OUTP<0>	35	CML output Lane 1 – Positive output
AGND	5, 6, 9, 11, 14, 16,	Analog ground
AVDD	15, 18, 22	Analog supply, 1.8 V
AVDD_3V	17	Analog supply for input buffer, 3.3 V
CLKM	8	Conversion clock – Negative input
CLKP	7	Conversion clock – Positive input
DRGND	29	Digital ground
DRVDD	27, 30	Digital supply, 1.8 V

PIN FUNCTIONS (continued)

PIN		DESCRIPTION
NAME	NO.	
DETECT<3>	36	Signal level detect output pins: Can be used to either output a 4-bit ADC code with low latency or to output a 16-level RMS power estimate
DETECT<2>	37	
DETECT<1>	38	
DETECT<0>	39	
DFS_EXTREF	3	4-level analog control for Data Format select and Internal/ External reference mode
FAVDD	20	Fuse supply – connect externally to AVDD, 1.8 V
IOVDD	33	CML buffer supply – 1.2 V to 1.9 V
INM	13	Analog input - Negative
INP	12	Analog input – Positive
MODE	19	4-level control for Serial interface/ Parallel interface modes selection
OVR	40	Over-range output
PDN	21	Full chip Powerdown (also referred to as Complete Powerdown mode)
PDN_ANA	4	Analog section power down, JESD interface still active. This is referred to as fast recovery powerdown mode
RESET	26	Chip Reset input
SCLK_SERF0_SCR	25	In Serial interface mode : Serial clock input In parallel interface mode : 4-level control for JESD modes (single/dual lane & scrambling)
SDATA_TEST0	24	In Serial interface mode : Serial data input In parallel interface mode : JESD test mode
SDOUT_TEST1	28	In Serial interface mode : Serial data output (for register readout) In parallel interface mode : JESD test mode
SEN_FALIGN_I DLE	23	In Serial interface mode : Serial enable (Chip select) In parallel interface mode : 4-level control for JESD modes
SYNC~M	1	JESD Synchronization request – Negative input
SYNC~P	2	JESD Synchronization request – Positive input
VCM	10	Common mode output for setting input common mode: 1.95V, Reference input in external reference mode

ABSOLUTE MAXIMUM RATINGS⁽¹⁾

		VALUE	UNIT
AVDD	Supply voltage range	-0.3 to +2.2	V
DRVDD		-0.3 to +2.2	V
IOVDD		-0.3 to +2.2	V
AVDD_3V		-0.3 to +3.9	V
	Voltage between AGND and DRGND	-0.3 to +0.3	V
	Voltage applied to external VCM pin	-0.3 to +2.2	V
	Voltage applied to analog input pins	-0.3 to min (3, AVDD_3V + 0.3)	V
	Voltage applied to digital input pins	-0.3 to AVDD + 0.3	V
	Voltage applied to clock input pins ⁽²⁾	-0.3 to AVDD + 0.3	V
T _A	Operating free-air temperature range	-40 to 85	°C
	Peak solder temperature	260	°C
	Junction temperature	105	°C

- (1) Stresses above these ratings may cause permanent damage. Exposure to absolute maximum conditions for extended periods may degrade device reliability.
- (2) When AVDD is turned off, it is recommended to switch off the input clock (or ensure the voltage on CLKP, CLKM is less than |0.3V|. This prevents the ESD protection diodes at the clock input pins from turning on.

THERMAL INFORMATION

THERMAL METRIC ⁽¹⁾		ADS61JB23	UNITS
		QFN 40 PIN	
θ_{JA}	Junction-to-ambient thermal resistance	30.7	°C/W
θ_{JCTop}	Junction-to-case (top) thermal resistance	17	
θ_{JB}	Junction-to-board thermal resistance	5.7	
Ψ_{JT}	Junction-to-top characterization parameter	0.2	
Ψ_{JB}	Junction-to-board characterization parameter	5.7	
θ_{JCbott}	Junction-to-case (bottom) thermal resistance	1	

(1) For more information about traditional and new thermal metrics, see the *IC Package Thermal Metrics* application report, [SPRA953](#).

RECOMMENDED OPERATING CONDITIONS

		MIN	TYP	MAX	UNIT
SUPPLIES, ANALOG INPUTS AND REFERENCE VOLTAGES					
Analog supply voltage, AVDD		1.7	1.8	1.9	V
Digital supply voltage, DRVDD		1.7	1.8	1.9	V
CML buffer supply voltage, IOVDD		1.2	1.8	1.9	V
Analog buffer supply voltage, AVDD_3V		3.0	3.3	3.6	V
Differential input voltage range		2			V _{PP}
Input common-mode voltage		VCM ±0.05			V
VCM (output) – Internal reference mode ⁽¹⁾		1.95			V
VCM (input) – External reference mode		1.4			V
CLOCK INPUT					
Input clock rate in JESD204A single lane mode		15.625		80	MSPS
Input clock rate in JESD204A dual lane mode		31.25		80	MSPS
Input clock amplitude differential (V _{CLKP} - V _{CLKM})	Sine wave, ac-coupled	0.2	3.0		V _{PP}
	LVPECL, ac-coupled		1.6		V _{PP}
	LVDS, ac-coupled		0.7		V _{PP}
	CMOS, single-ended, ac-coupled		1.5		V
Input clock duty cycle		35%	50%	65%	
DIGITAL OUTPUTS					
Output data rate in single-lane mode		312.5	20x (sample rate)	1600	MBPS
Output data rate in dual-lane mode		312.5	10x (sample rate)	800	MBPS
C _{LOAD}	Maximum external load capacitance from each pin to DRGND	5			pF
R _{LOAD}	External termination from each output pin to IOVDD	50			Ω
T _A	Operating free-air temperature	-40		85	°C
HIGH SFDR MODE					
Write register 2h, value 71h to get best HD3 for input frequencies between 150MHz to 250MHz.					

(1) Typical VCM reduces to 1.85V after HIGH SFDR MODE is written.

ELECTRICAL CHARACTERISTICS

Typical values at 25°C, MIN and MAX values are across the full temperature range $T_{MIN} = -40^{\circ}C$ to $T_{MAX} = 85^{\circ}C$, AVDD = 1.8V, AVDD_3V = 3.3V, DRVDD = 1.8V, IOVDD = 1.8V, Clock frequency = 80MSPS, 50% clock duty cycle, -1dBFS differential analog input, internal reference mode, CML buffer current setting = 16 mA, unless otherwise noted.

PARAMETER		TEST CONDITIONS	MIN	TYP	MAX	UNIT
REFERENCE VOLTAGES – INTERNAL						
VCM analog input common mode voltage (output)				1.95		V
VCM output current (resulting in a VCM change of ± 50 mV)				2.5		mA
REFERENCE VOLTAGES – EXTERNAL						
VCM reference voltage (Input)				1.4 \pm 0.1		V
ANALOG INPUT						
Differential input voltage range				2.0		V _{pp}
Differential input capacitance				3		pF
Analog input bandwidth				480		MHz
Analog input common mode range				VCM \pm 0.05		V
Analog input common mode current (per input pin)				1.6		μ A
DC ACCURACY						
Offset error			-20		20	mV
Gain error	Due to internal reference inaccuracy alone		-2.5		2.5	%FS
	Due to channel alone				5	%FS
Gain error temperature coefficient				0.006		mV/ $^{\circ}C$
AC Power Supply Rejection Ratio, PSRR		50 mV _{pp} signal on AVDD supply		>30		dB
POWERDOWN MODES						
Complete powerdown mode				10		mW
Fast recovery powerdown mode				210		mW
Power with no clock				115		mW
DNL differential nonlinearity			-0.7	\pm 0.3	0.8	LSB
INL integral nonlinearity				\pm 0.7	\pm 1.5	LSB
POWER SUPPLY CURRENTS						
AVDD current				105	122	mA
AVDD_3V current				40	51	mA
DRVDD current				50	61	mA
IOVDD current				16	21	mA
Total power				440	500	mW
DYNAMIC PERFORMANCE⁽¹⁾						
SFDR	IF = 10 MHz			80		dBc
	IF = 185 MHz		70	80		dBc
SNR	IF = 10 MHz			71.7		dBFS
	IF = 185 MHz		68	70.5		dBFS
SINAD	IF = 10 MHz			71.2		dBFS
	IF = 185 MHz			70.1		dBFS
HD3	IF = 10 MHz			80		dBc
	IF = 185 MHz		70	80		dBc
HD2	IF = 10 MHz			100		dBc
	IF = 185 MHz		70	80		dBc
Worst spur (excluding HD2, HD3)	IF = 10 MHz			90		dBc
	IF = 185 MHz		81	87		dBc

(1) HIGH SFDR MODE is enabled.

DIGITAL CHARACTERISTICS

The DC specifications refer to the condition where the digital outputs are not switching, but are permanently at a valid logic level 0 or 1

PARAMETER	TEST CONDITIONS	MIN	TYP	MAX	UNIT
DIGITAL INPUTS					
High-level input voltage		1.2			V
Low-level input voltage				0.6	V
High-level input current	SEN		0		μA
	SCLK, SDATA, RESET, PDN, PDN_ANA		10		
Low-level input current	SEN		10		μA
	SCLK, SDATA, RESET, PDN, PDN_ANA		0		
DIGITAL OUTPUTS (SDOUT)					
High-level output voltage		DRVDD-0.1	DRVDD		V
Low-level output voltage			0	0.1	V
CML OUTPUTS – 50 Ω SINGLE-ENDED EXTERNAL TERMINATION TO IOVDD					
IOVDD supply range		1.2	1.8	1.9	V
High-level output voltage			IOVDD		V
Low-level output voltage			IOVDD-0.4		V
Output differential voltage, VOD			0.4		V
Output common-mode voltage, V _{OCM}			IOVDD-0.2		V
Transmitter short circuit current	Transmitter terminals shorted to any voltage between -0.25V and 1.45V	-90		50	mA
Single-ended output impedance			50		Ω
Unit interval, UI		625		3200	UI
Total Jitter, T _J			0.35		p-pUI
Rise/ fall times	5 pF single-ended load capacitance to ground		175		ps

WAKE-UP TIMING CHARACTERISTICS

PARAMETER	TEST CONDITIONS	MIN	TYP	MAX	UNIT
Wake-up time	Time to valid data after coming out of COMPLETE POWERDOWN mode		50		μs
	Time to valid data after coming out of FAST RECOVERY POWERDOWN mode		50		μs
	Time to valid data after coming out of SOFTWARE POWERDOWN mode		10		μs
	Time to valid data after stopping and restarting the input clock		5		μs

DETAILED DESCRIPTION

JESD204A OUTPUT INTERFACE

The 12-bit ADC output is padded with 4 zeros on the LSB side to form a 16-bit output. Two 8B10B codes are formed – one from the 8 MSBs and the other from the 6 LSBs and the 2 padded zeros .

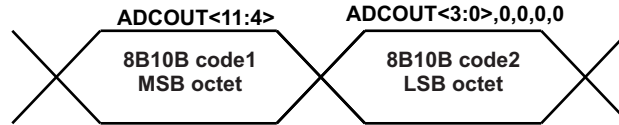

Figure 1. Mapping of ADC Output to Two 8B10B Codes

The two octets can be either transmitted on the same lane (single lane interface) or on two lanes (dual lane interface). By default, the device operates in single lane interface.

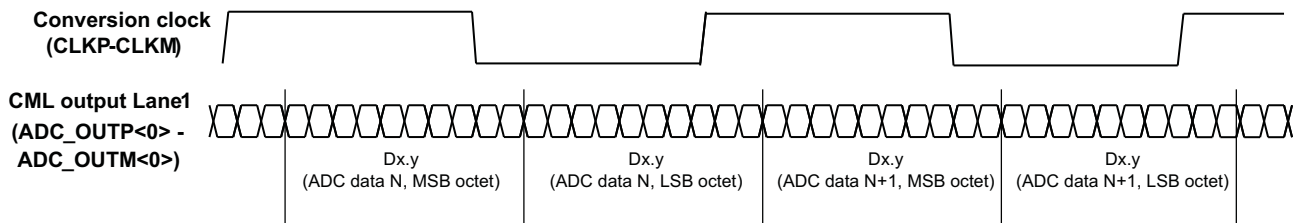

Figure 2. Single Lane Timing

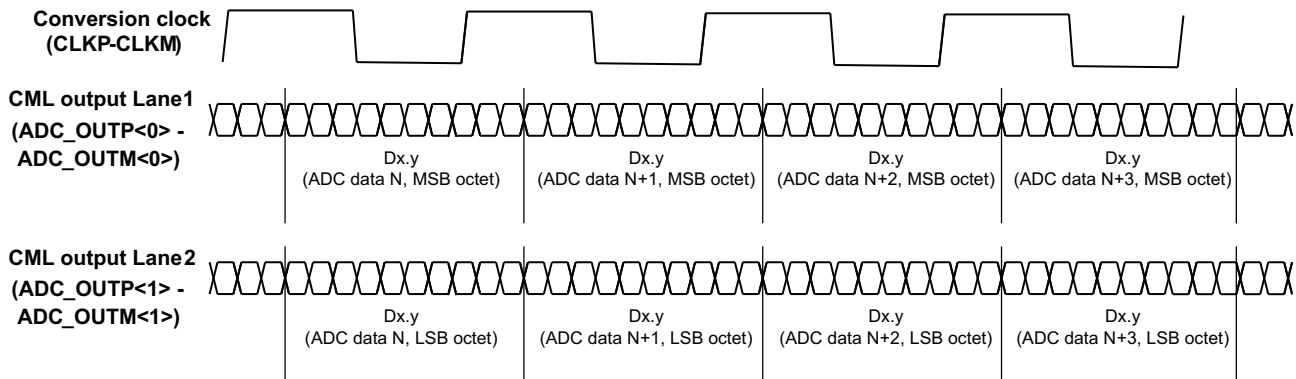
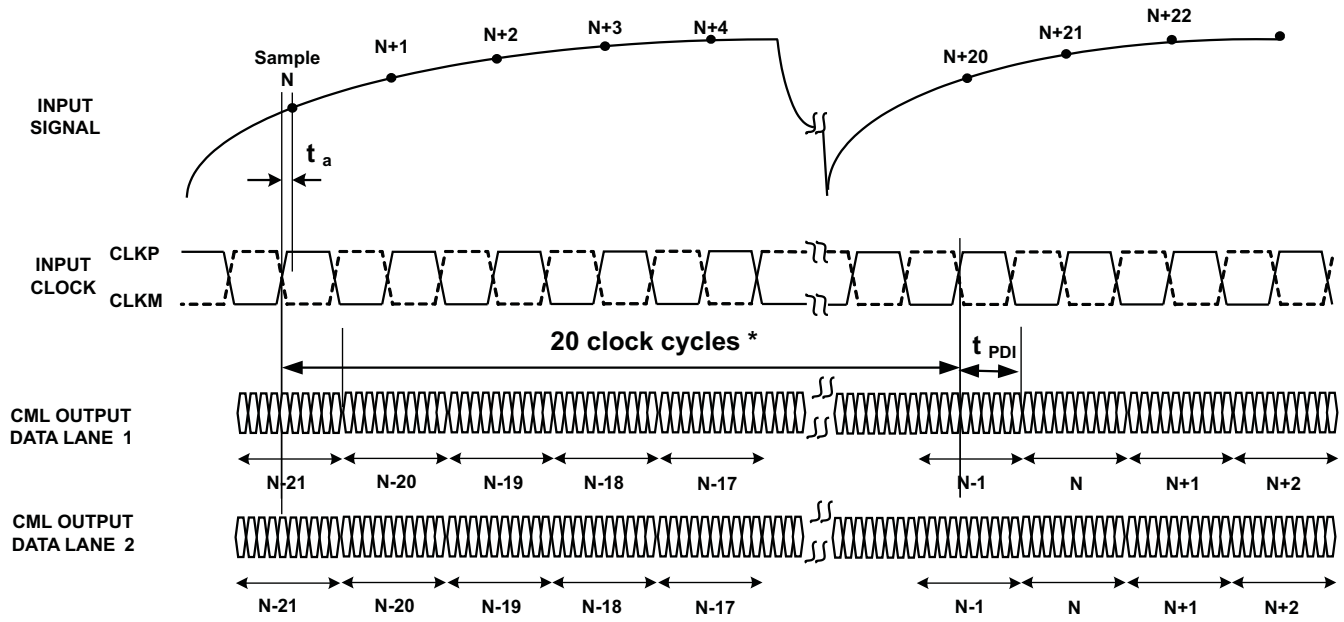

Figure 3. Dual Lane Timing

The detailed timing diagram in the dual lane mode is shown below:



* This is the ADC latency. At higher sampling frequencies, $t_{PDI} > 1$ clock cycle. Then, overall latency = ADC latency + 1.

Figure 4. Data Timing Diagram - Dual Lane Mode

PARAMETER	30 MSPS	40 MSPS	60 MSPS	80 MSPS
Aperture delay – T_A	560 ps	560 ps	560 ps	560 ps
Aperture jitter (RMS) – T_J	125 fs	125 fs	125 fs	125 fs
Latency	20 clocks	20 clocks	20 clocks	20 clocks
t_{PDI} Data propagation delay	33.3 ns	26.2 ns	18.9 ns	15.3 ns

Whenever there is a need to synchronize to the frame boundary of the output data stream, the receiver issues a synchronization request through the SYNC~P, SYNC~M pins. Below diagram shows how the transmission switches from normal data (D) to code group synchronization symbols K28.5 symbols during and after a synchronization request.

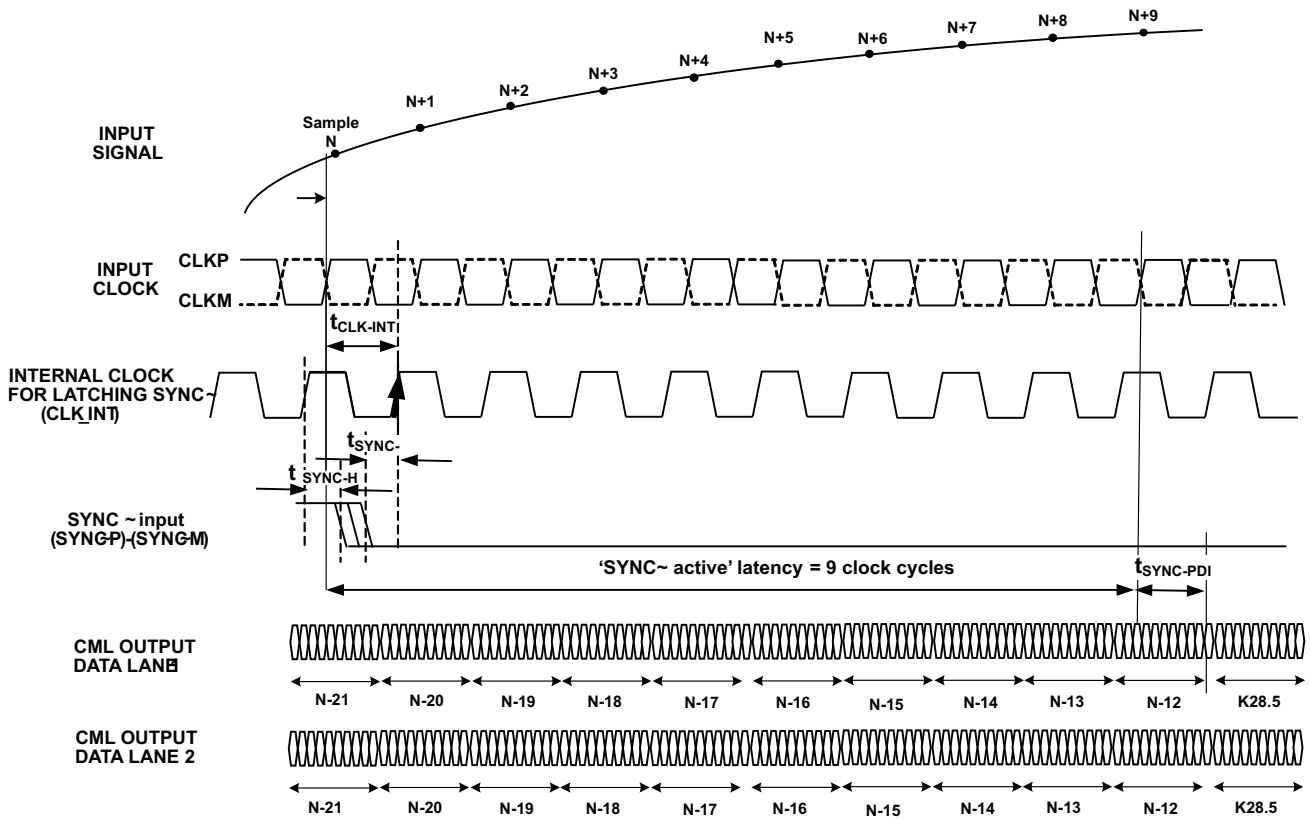

Figure 5. SYNC~ ACTIVE Timing Diagram

Table 1. SYNC~ Falling Edge Timing at 80 MSPS

PARAMETER	DESCRIPTION	TYP	UNIT
$t_{CLK-INT}$	Delay from input clock rising edge to the rising edge of the internal clock (CLK_INT) used to latch falling edge of SYNC~	10.5	ns
$t_{SYNC-SU}$	SYNC~ active edge setup time	2	ns
t_{SYNC-H}	SYNC~ active edge hold time	2	ns
	SYNC~ active latency	9	clocks
$t_{SYNC-PDI}$	SYNC~ data propagation delay	15.3	ns

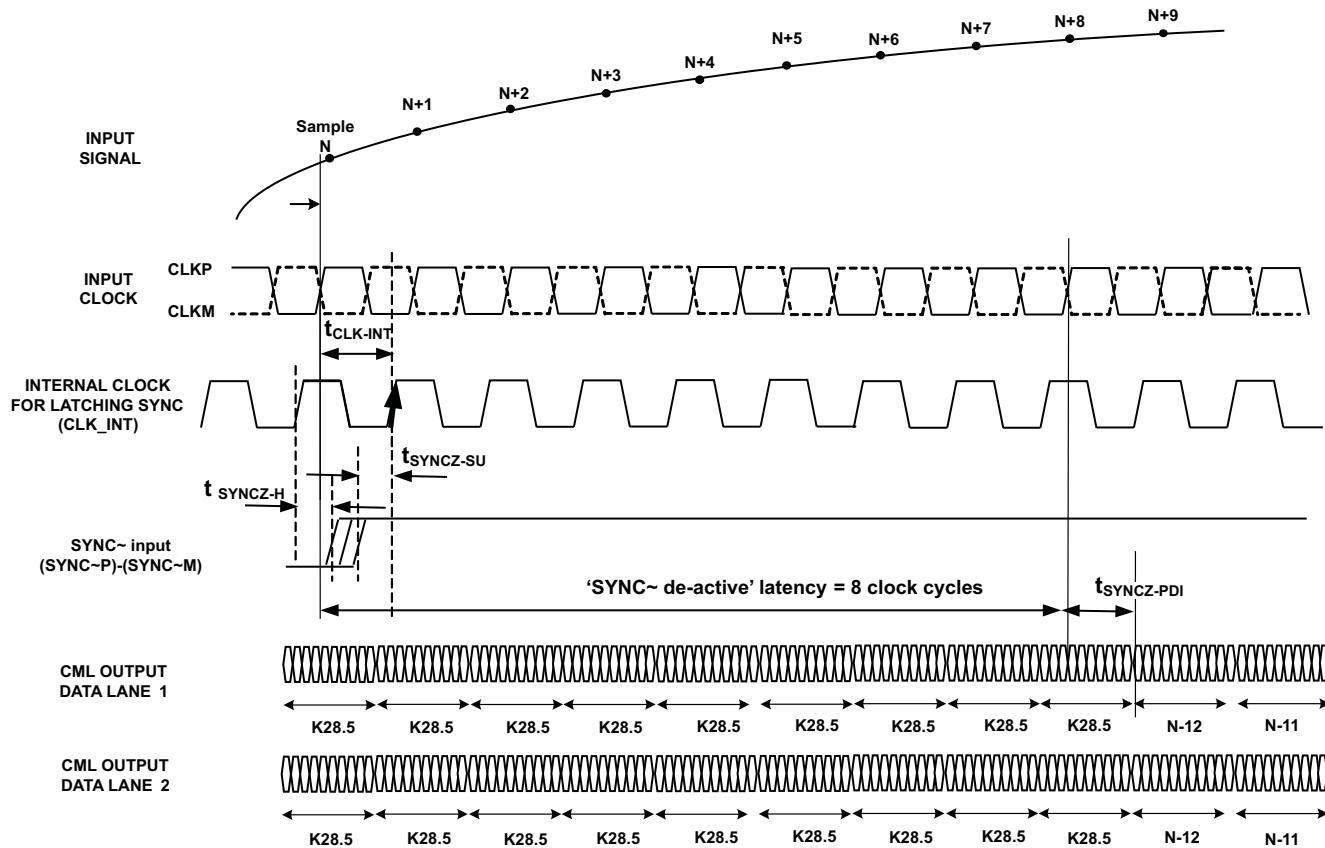

Figure 6. SYNC~ DE-ACTIVE Timing Diagram

Table 2. SYNC~ Rising Edge Timing at 80 MSPS

PARAMETER	DESCRIPTION	TYP	UNIT
$t_{CLK-INT}$	Delay from input clock rising edge to the rising edge of the internal clock (CLK_INT) used to latch rising edge of SYNC~	10.5	ns
$t_{SYNCZ-SU}$	SYNC~ active edge setup time Minimum delay required from SYNC~ rising edge to CLK_INT rising edge	2	ns
$t_{SYNCZ-H}$	SYNC~ active edge hold time Minimum delay required from CLK_INT rising edge to SYNC~ rising edge	2	ns
	SYNC~ de-active latency Number of clocks for normal data to appear at the output after a SYNC~ de-activate request	8	clocks
$t_{SYNCZ-PDI}$	SYNC~ de-active data propagation delay Similar to data propagation delay	15.3	ns

4-LEVEL CONTROL

In the ADS61JB23 the DFS_EXTREF and MODE pins function as 4-level control pins as described in Table 3 and Table 4. A simple scheme to generate 4-level voltage is shown in Figure 7.

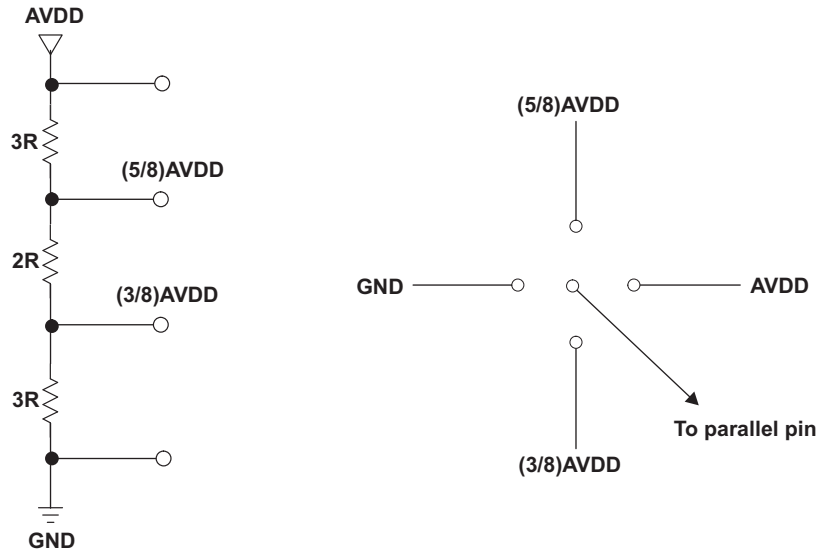

Figure 7. Simple Scheme to Configure 4-Level Control Pins

Table 3. Pin 3 – DFS_EXTREF

DFS_EXTREF	DESCRIPTION
0 +150 mV/-0 mV	EXTREF = 0, DFS = 0
(3/8)AVDD ±150 mV	EXTREF = 1, DFS = 0
(5/8)AVDD ±150 mV	EXTREF = 1, DFS = 1
AVDD +0 mV/-150 mV	EXTREF = 0, DFS = 1

Key:

EXTREF: 0 = Internal reference mode, 1 = External reference mode.
DFS: 0 = 2's complement output, 1 = Offset binary output.

PARALLEL INTERFACE MODE

The ADS61JB23 operates in parallel interface mode when a suitable voltage is applied on the MODE pin as described in [Table 4](#). In parallel interface mode, the SEN, SDATA, SCLK, and SDOOUT pins function differently compared to serial interface mode. In this mode, the SEN_FALIGN_IDLE and SCLK_SERF0_SCR pins turn into 4-level control pins for JESD interface as described in [Table 5](#) and [Table 6](#), whereas the SDATA_TEST0 and SDOOUT_TEST1 pins turn into 2-level control pins as described in [Table 7](#).

Table 4. Pin 19 - Mode

MODE	DESCRIPTION
0 +150 mV/-0 mV	Serial interface mode. Pins 23, 24 and 25 are configured as SEN, SDATA, SCLK. Pins 36, 37, 38, 39 are configured to output either early signal estimate or signal power estimate – selection is based on register settings.
(3/8)AVDD ±150 mV	Do not use
(5/8)AVDD ±150 mV	Parallel interface mode. Pins 23, 24 and 25 are configured as parallel input pins for controlling JESD204A modes. Pins 36,37,38, 39 outputs early signal estimate always.
AVDD +0 mV/-150 mV	Do not use.

Table 5. Pin 23 - SEN_FALIGN_IDLE (in Parallel Interface Mode)

SEN_FALIGN_IDLE	DESCRIPTION
0 +150 mV/-0 mV	FALIGN = 0, IDLE = 0
(3/8)AVDD ±150 mV	FALIGN = 1, IDLE = 0
(5/8)AVDD ±150 mV	FALIGN = 1, IDLE = 1
AVDD +0 mV/-150 mV	FALIGN = 0, IDLE = 1

Key:

FALIGN: When the last octet of the current frame is the same as the last octet of the previous frame, then FALIGN determines whether the last octet of the current frame is transmitted as is, or replaced by a K28.7 control symbol. When FALIGN=0, it is transmitted as is. When FALIGN=1, it is replaced with a K28.7 control symbol.

IDLE: IDLE determines the synchronization characters transmitted during and immediately after a SYNC event. When IDLE=0, the device transmits K28.5 as per the JESD204A spec. When IDLE=1, the device alternately transmits K28.5 and D5.6/D16.2 characters as per IEEE Std 802.3-2002 part3, Clause 36.2.4.12. This is the case in both single and dual lane modes.

Table 6. Pin 25 - SCLK_SERF0_SCR (in Parallel Interface Mode)

SCLK_SERF0_SCR	DESCRIPTION
0 +150 mV/-0 mV	SERF0 = 0, SCR = 0
(3/8)AVDD ±150 mV	SERF0 = 1, SCR = 0
(5/8)AVDD ±150 mV	SERF0 = 1, SCR = 1
AVDD +0 mV/-150 mV	SERF0 = 0, SCR = 1

Key:

SERF0: Output serialization factor. When SERF0=0, the device transmits 2 octets per frame (entire ADC channel in a single lane) with an output serialization factor of 20. When SERF0=1, the device transmits 1 octet per frame (ADC channel over 2 lanes) with an output serialization factor of 10.

SCR: SCR=0: Scrambling disabled. SCR=1: Scrambling (as per JESD204A) enabled

Table 7. Pins 24 and 28 - SDATA_TEST0 and SDOUT_TEST1 (in Parallel Interface Mode)

TEST1	TEST0	MODE
0	0	Normal mode. Input to JESD204A encoder is ADC data
0	1	Input to JESD204A encoder is B5B5. Output is a stream of D21.5 (alternating 1 and 0)
1	0	Input to JESD204A encoder is FF00
1	1	Input to JESD204A encoder is a pseudo random pattern $1 + X^{14} + X^{15}$ (irrespective of whether scrambler is enabled or not)

SERIAL INTERFACE

The ADC has a set of internal registers, which can be accessed by the serial interface formed by pins Serial interface Enable (SEN), Serial Interface Clock (SCLK) and Serial Interface Data (SDATA).

Serial shift of bits into the device is enabled when SEN is low. Serial data SDATA is latched at every falling edge of SCLK when SEN is active (low). The serial data is loaded into the register at every 16th SCLK falling edge when SEN is low. In case the word length exceeds a multiple of 16 bits, the excess bits are ignored. Data can be loaded in multiple of 16-bit words within a single active SEN pulse.

The first 8 bits form the register address and the remaining 8 bits are the register data. The interface can work with SCLK frequency from 20 MHz down to very low speeds (few Hertz) and also with non-50% SCLK duty cycle.

REGISTER INITIALIZATION

After power-up, the internal registers MUST be initialized to their default values. This can be done in one of two ways:

1. Either through hardware reset by applying a high-going pulse on RESET pin (of width greater than 10ns) as shown in [Figure 8](#)

OR

2. By applying software reset. Using the serial interface, set the S_RESET bit (D1 in register 0x00) to HIGH. This initializes internal registers to their default values and then self-resets the S_RESET bit to LOW. In this case the RESET pin is kept LOW.

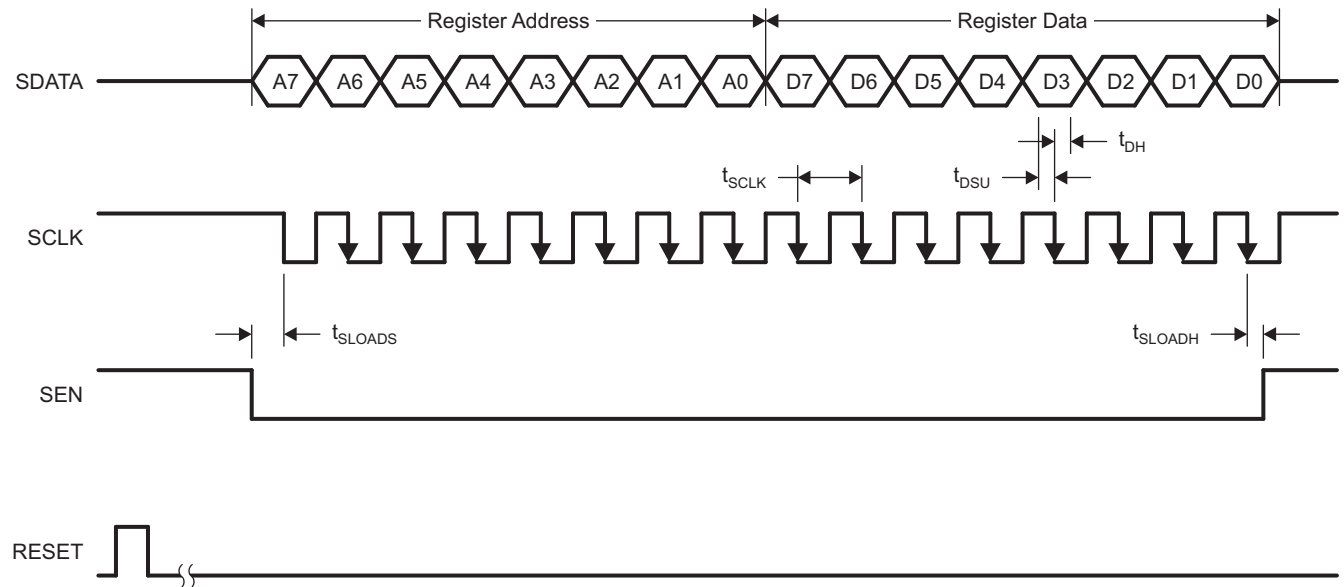

Figure 8. Serial Interface Timing

T0109-04

SERIAL INTERFACE TIMING CHARACTERISTICS

Typical values at 25°C, MIN and MAX values across the full temperature range $T_{MIN} = -40^{\circ}C$ to $T_{MAX} = 85^{\circ}C$, AVDD = 1.8V, DRVDD = 1.8V, unless otherwise noted.

PARAMETER		MIN	TYP	MAX	UNIT
f_{SCLK}	SCLK frequency (= $1/t_{SCLK}$)	> DC		20	MHz
t_{SLOADS}	SEN to SCLK setup time	25			ns
t_{SLOADH}	SCLK to SEN hold time	25			ns
t_{DS}	SDATA setup time	25			ns
t_{DH}	SDATA hold time	25			ns

Serial Register Readout

The device includes an option where the contents of the internal registers can be read back. This may be useful as a diagnostic check to verify the serial interface communication between the external controller and the ADC.

1. First, set register bit <SERIAL READOUT> = 1. This also disables any further writes into the registers (EXCEPT register bit <SERIAL READOUT> itself).
2. Initiate a serial interface cycle specifying the address of the register (A7-A0) whose content has to be read.
3. The device outputs the contents (D7-D0) of the selected register on SDOUT_TEST1 pin.
4. The external controller can latch the contents at the falling edge of SCLK.
5. To enable register writes, reset register bit <SERIAL READOUT> = 0.

RESET TIMING

Typical values at 25°C, MIN and MAX values across the full temperature range $T_{MIN} = -40^{\circ}C$ to $T_{MAX} = 85^{\circ}C$, unless otherwise noted.

PARAMETER	CONDITIONS	MIN	TYP	MAX	UNIT
t_1	Power-on delay		1		ms
t_2	Reset pulse width	10			
t_3	Delay from RESET disable to SEN active	100			ns

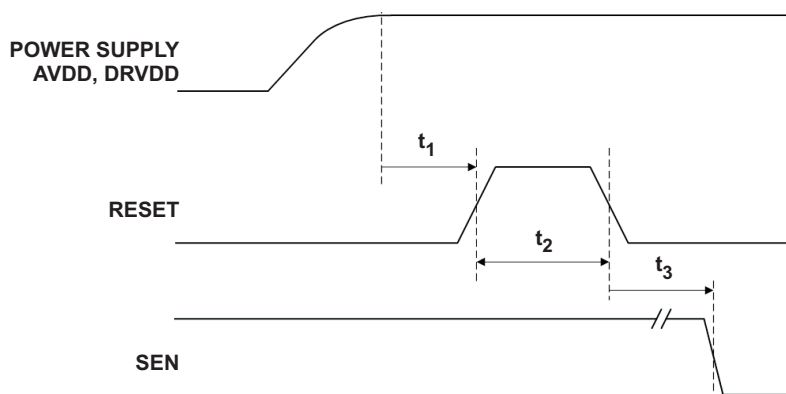

NOTE: A high-going pulse on RESET pin is required in case of initialization through hardware reset.

Figure 9. Reset Timing Diagram

SERIAL INTERFACE REGISTER MAP

MODE	BIT LOCATION (Address in Hex <Bit location>)	DESCRIPTION
S_RESET	00<1>	Software RESET. Same function as hardware reset.
SERIAL_READOUT	00<0>	Default = 0 for serial interface write. 1 for serial readout.
HIGH_SFDR_MODE	2<6:4> and 2<0>	Set these bits to get best HD3 when input frequency is between 150MHz to 250MHz.
DFS_OVERRIDE	3C<7>	Override control of DFS_EXTREF pin in controlling DFS select mode, and control it using register bit DFS_REG. When '0', DFS functionality determined by DFS_EXTREF pin. When '1', DFS functionality determined by DFS_REG.
DFS_REG	3C<6>	Register bit for DFS control. When '0', output format is 2's complement. When '1', output format is offset binary. Takes effect when DFS_OVERRIDE is set to '1'.
INT_REF_OVERRIDE	44<3>	Override control of DFS_EXTREF pin in controlling Internal/ External reference select mode, and control it using register bit INT_REF_REG. When '0', Internal/ External reference mode determined by DFS_EXTREF pin. When '1', Internal/ External reference mode determined by INT_REF_REG.
INT_REF_REG	44<2>	Register bit for Internal/ External reference mode control. When '0', Internal reference mode. When '1', External reference mode. Takes effect when INT_REF_OVERRIDE is set to '1'.
S_PDN	44<6>	Software powerdown.
FINE_GAIN<3:0>	45<7:4>	0-6 dB digital gain in steps of 0.5 dB. Default is 0 dB. Refer section titled "FINE GAIN CONTROL"
BYPASS_FINE_GAIN	45<3>	Digital gain bypass. When set to 1, fine gain is bypassed.
ADC_TEST_PAT<2:0>	45<2:0>	Output Test patterns: 000: ADC output data bus is input to JESD204A encoder block 001: ADC bus replaced by min code (00000000000000 in offset binary). 010: ADC bus replaced by max code (11111111111111 in offset binary). 100: ADC bus replaced by a ramping code pattern that increments by 1 LSB every 4 clocks (and folds back to min code once max code is reached). 011,101,110,111: Do not use
TXMIT_LINKDATA_EN	A0<0>	When set to 1, initial lane alignment sequence (as per JESD204A) is sent after Code group sync in both single lane and dual lane interfaces. When this bit is 0 (default) initial lane alignment sequence is not transmitted.
S_FALIGN	A0<1>	Software Frame Align control. Enables frame alignment monitoring. When this bit is set to 1 (with scrambling turned off) – If the last octet in the previous frame is the same as the last octet in the current frame, then the last octet in the current frame will be replaced with a frame alignment symbol K28.7. When this bit is 0, there is no replacement. When scrambling is ON and this bit is '1': When the last scrambled octet in a frame equals 0xFC, it is encoded as K28.7. This bit control is similar to the FALIGN pin control.
MFALIGN	A0<2>	Multi-frame Align control. Similar to frame align, this refers to multi-frame. Multi-frame alignment symbol is K28.3.
FLIP_ADC_BUS	A0<3>	By default, the last octet in the frame gets derived from the data octet on the LSB side. Since usually the LSB octets switch more (frame to frame) than the MSB octets, the occurrence of consecutive "last octets" might be rare. This might lead to infrequent occurrence of frame alignment symbols. To increase the rate of consecutive last octets (and thereby the rate of frame and multi-frame alignment symbols), this bit can be set to 1. Setting this bit to 1 will flip the bit order of the ADC inputs (N bits) to the JESD204A logic. Note that the 2 zeros padded at the end to make the input to the JESD204A logic remain unchanged.
TESTMODE_EN	A0<4>	Enables the transmission of test sequence mentioned in the JESD204A document.
S_IDLE	A0<5>	Software idle generation control. Normally the output during code group synchronization is K28.5. When idle_sync is set to 1, it is a K28.5 comma followed by either a D5.6 or a D16.2. This is as per IEEE Std 802.3-2002 part3, Clause 36.2.4.12 and enables compatibility with TI's TLK family of devices. This bit control is similar to the IDLE pin control.
S_TEST0	A0<6>	These 2 bit controls are similar to the TEST1 and TEST0 pin controls.
S_TEST1	A0<7>	
CTRL_F	A1<0>	Enables write into A6<7:0>.
CTRL_K	A1<1>	Enables write into A7<4:0>.
S_SCR	A5<7>	Software Scrambling enable. This bit control is similar to the SCR pin control.

MODE	BIT LOCATION (Address in Hex <Bit location>)	DESCRIPTION
F<7:0>	A6<7:0>	Number of octets per frame. Default set to 00000001 (2-1) which is 2 octets per frame (single lane). For 2-lane output (1 octet per frame), set to 00000000. Note that to override default, CTRL_F needs to be set to 1.
K<4:0>	A7<4:0>	Number of frames per multiframe (minus 1). Default depends on value of F<7:0>. When F=0 (10X mode): K=16 (17 frames per multiframe) When F=1 (20X mode): K=8 (9 frames per multiframe) Note that to override the default value of K<4:0>, CTRL_K needs to be set to 1. When CTRL_K is set to 1, the value programmed in A7<4:0> denotes the number of frames per multiframe (minus 1). For eg., to set the number of frames per multiframe to 23, set CTRL_K=1 and A7<4:0>=10110.
CML_I<3:0>	B0<3:0>	CML buffer current select. Default (0000) is 16 mA. Current is calculated as: 16 mA+16 mA×<3>-8 m×<2>-4 mA×<1>-2 mA×<0>
FORCE_OUT_LANE1	B4<3>	Replaces the output of the 8b/10b coder (corresponding to the MSB octet) with a 10-bit word specified in OUT_WORD_LANE1<9:0>
OUT_WORD_LANE1<9:0>	B6<7:0>, B7<7:6>	10-bit word replacing the output of the 8b/10b coder when FORCE_OUT_LANE1 is set to '1'
FORCE_OUT_LANE2	B4<6>	Replaces the output of the 8b/10b coder (corresponding to the LSB octet) with a 10-bit word specified in OUT_WORD_LANE2<9:0>
OUT_WORD_LANE2<9:0>	B8<7:4>, B9<7:2>	10-bit word replacing the output of the 8b/10b coder when FORCE_OUT_LANE2 is set to '1'
EN_SIG_EST	D6<0>	Outputs a 4-bit ADC code with low latency on pins DETECT<3:0>
EN_PWR_EST	D6<5>	Outputs a 4-bit average power estimate of input signal on DETECT<3:0>. Power estimate is in dB scale in steps of roughly 1 dB. Refer section titled SIGNAL POWER ESTIMATION
SAMPLES_PWR_EST<2:0>	D6<4:2>	Determines number of samples to average for power estimation. Programmable from 1K to 16K.

REGISTER MODES

A brief summary of different register modes and their location in the digital processing flow of the ADS61JB23 is shown in Figure 10 and Figure 11.

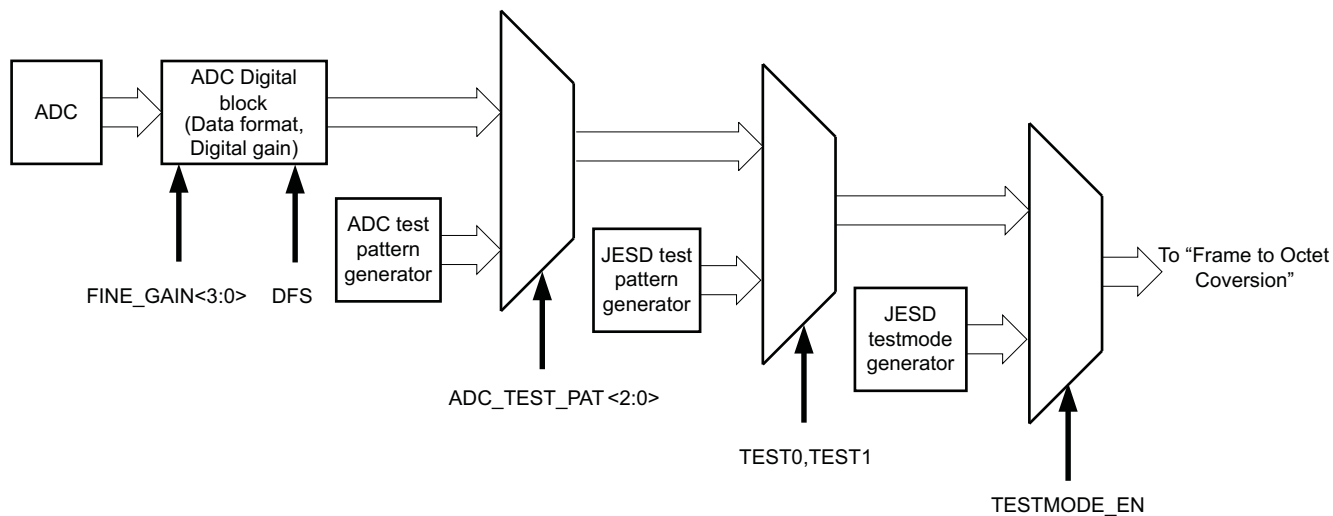

Figure 10. Register Modes Preceding Frame to Octet Conversion Block

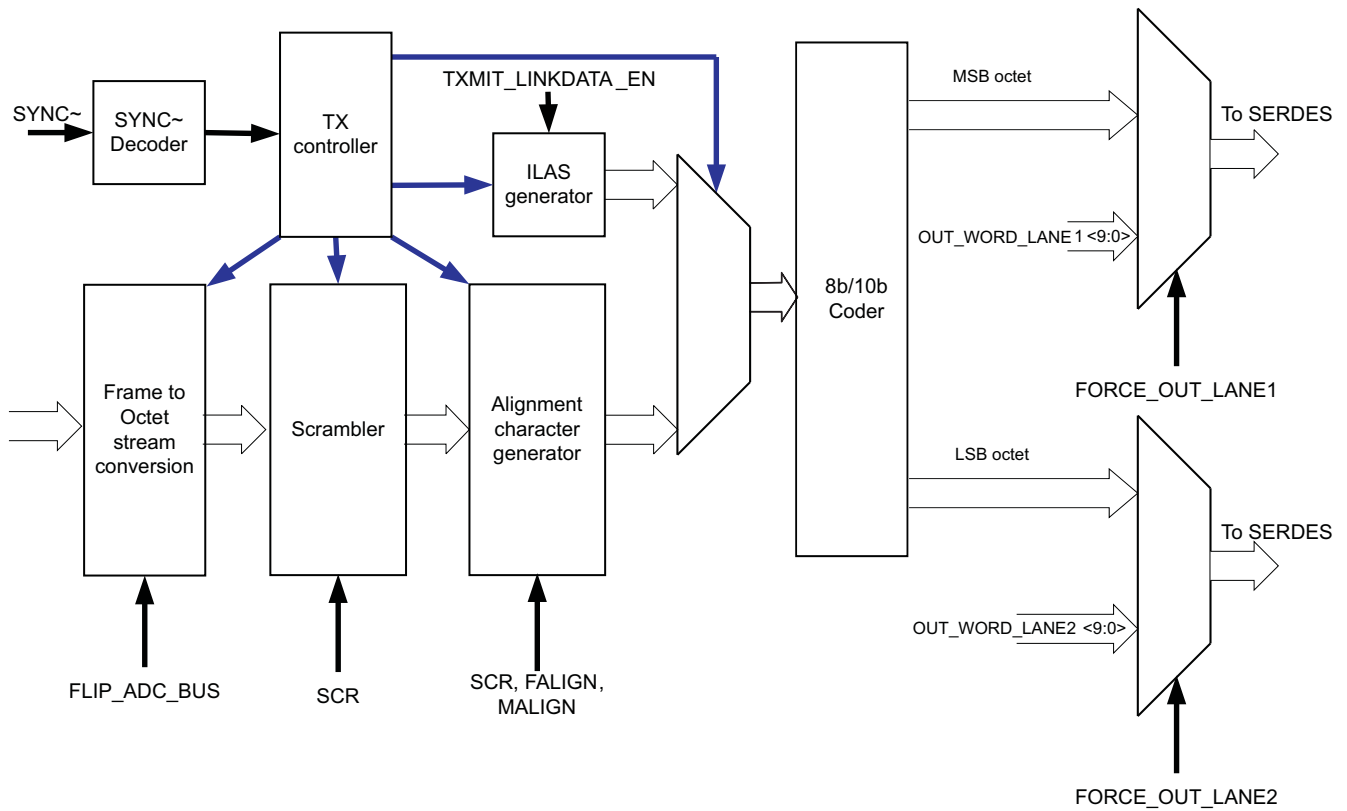

Figure 11. Register Modes Following Frame to Octet Conversion Block

INITIAL LANE ALIGNMENT SEQUENCE

By default the initial lane alignment sequence is not transmitted. To enable transmission of the initial lane alignment sequence,

For the two settings of F, the Mapping of link configuration fields to octets Table of the JESD204A spec is shown in [Table 8](#).

Table 8. Mapping of Link Configuration Fields to Octets

Configuration Octet No.	MSB	6	5	4	3	2	1	LSB
F=1 (20X mode)								
0	DID<7:0> = 00000000							
1	X	X	X	X	BID<3:0> = 0000			
2	X	X	X	LID<4:0> = 00000				
3	SCR<0> - set by S_SCR	X	X	L<4:0> = 00000				
4	F<7:0> = 00000001							
5	X	X	X	K<4:0> = 01000 (or programmed value of A7<4:0> if CTRL_K = 1)				
6	M<7:0> = 00000000							
7	CS<1:0>=00		X	N<4:0> = 01101				
8	X	X	X	N'<4:0> = 01111				
9	X	X	X	S<4:0>=00000				
10	HD<0>=0	X	X	CF<4:0>=00000				
11	RES1<7:0> - Set to all 0							
12	RES2<7:0> - Set to all 0							
13	FCHK<7:0>							
F=0 (10X mode)								
0	DID<7:0> = 00000000							
1	X	X	X	X	BID<3:0> = 0000			
2	X	X	X	LID<4:0> = 00000 for Lane 1 and 00001 for Lane 2				
3	SCR<0> - set by S_SCR	X	X	L<4:0> = 00001				
4	F<7:0> = 00000000							
5	X	X	X	K<4:0> = 10000 (or programmed value of A7<4:0> if CTRL_K = 1)				
6	M<7:0> = 00000000							
7	CS<1:0>=00		X	N<4:0> = 01101				
8	X	X	X	N'<4:0> = 01111				
9	X	X	X	S<4:0>=00000				
10	HD<0>=0	X	X	CF<4:0>=00000				
11	RES1<7:0> - Set to all 0							
12	RES2<7:0> - Set to all 0							
13	FCHK<7:0>							

TYPICAL CHARACTERISTICS

At +25°C, AVDD = 1.8V, AVDD_3V = 3.3V, DRVDD = 1.8V, maximum rated sampling frequency, sine wave input clock, 1.5VPP differential clock amplitude, 50% clock duty cycle, -1dBFS differential analog input, low-latency mode, DDR LVDS output interface, and 32k-point FFT, unless otherwise noted. Note that after reset, the device is in 0dB gain mode

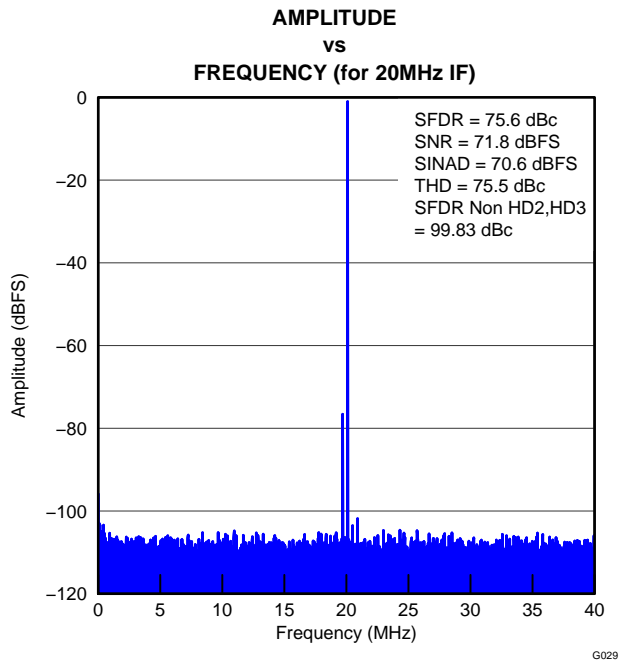

Figure 12.

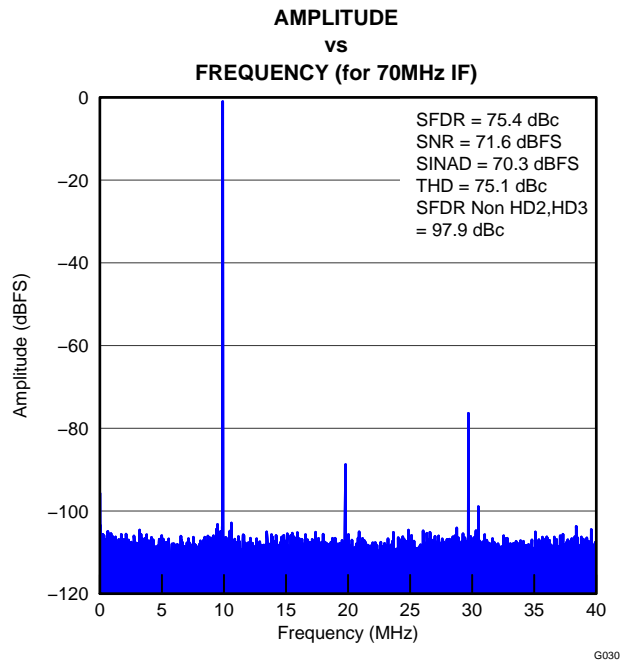

Figure 13.

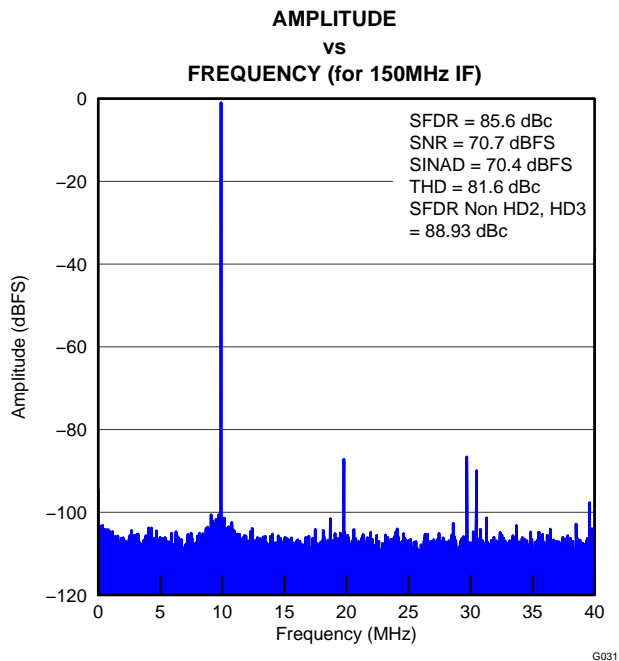

Figure 14.

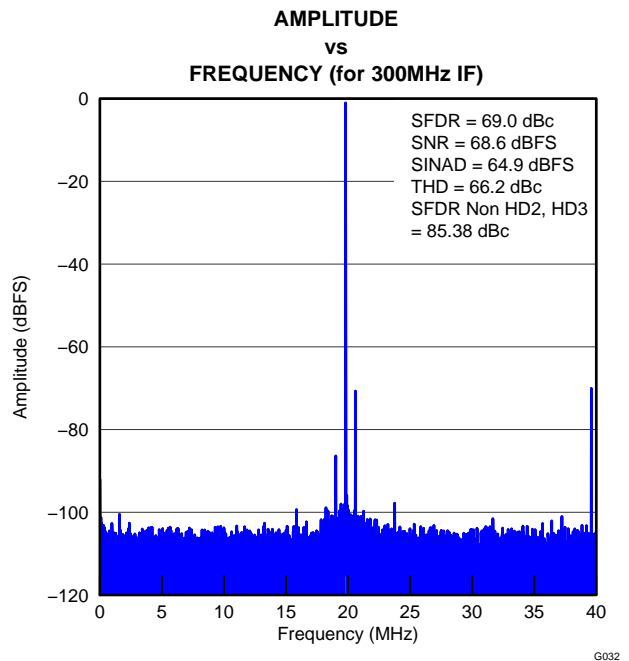

Figure 15.

TYPICAL CHARACTERISTICS (continued)

At +25°C, AVDD = 1.8V, AVDD_3V = 3.3V, DRVDD = 1.8V, maximum rated sampling frequency, sine wave input clock, 1.5VPP differential clock amplitude, 50% clock duty cycle, -1dBFS differential analog input, low-latency mode, DDR LVDS output interface, and 32k-point FFT, unless otherwise noted. Note that after reset, the device is in 0dB gain mode

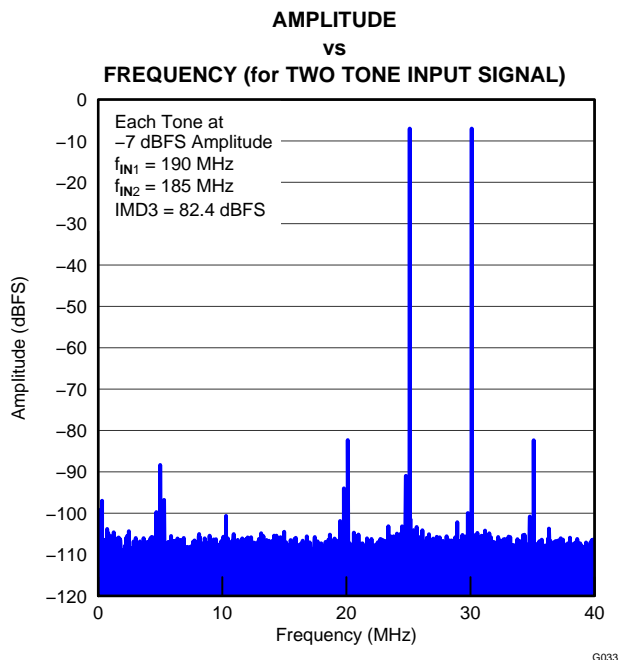

Figure 16.

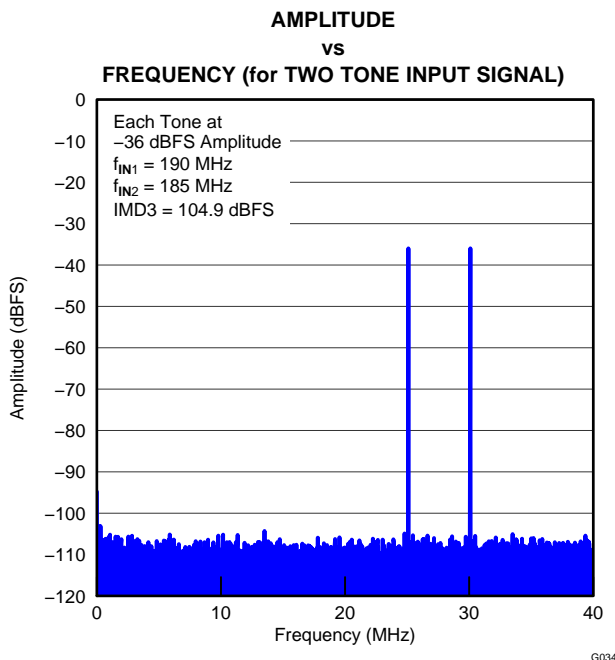

Figure 17.

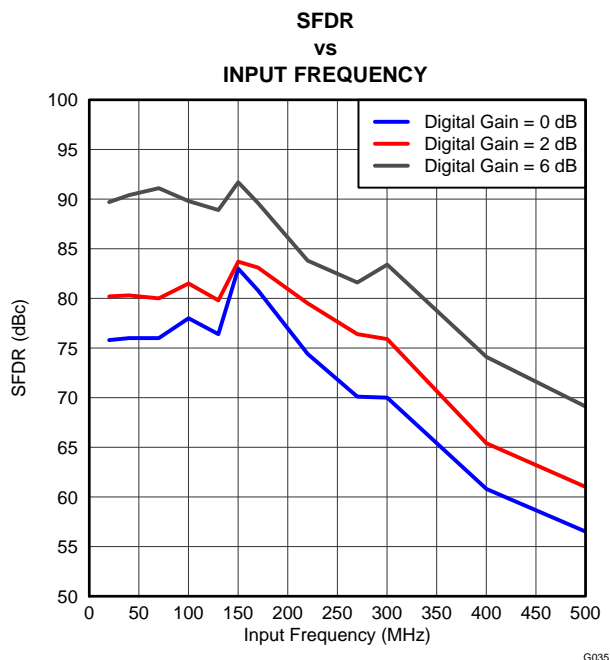

Figure 18.

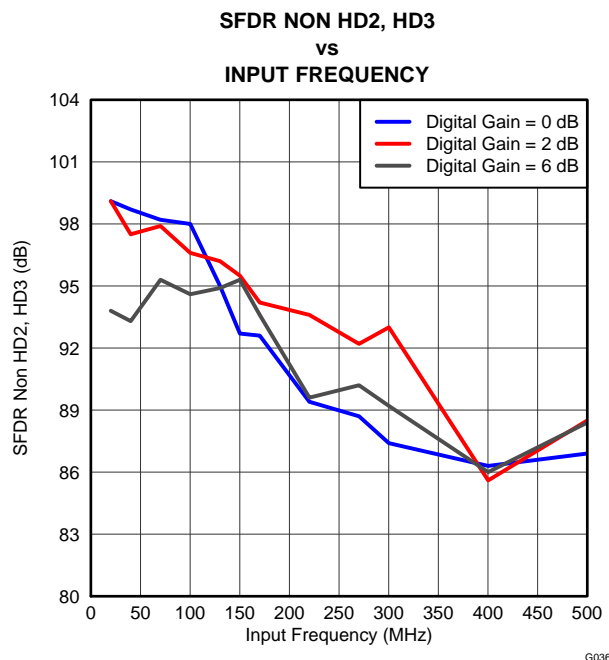

Figure 19.

TYPICAL CHARACTERISTICS (continued)

At +25°C, AVDD = 1.8V, AVDD_3V = 3.3V, DRVDD = 1.8V, maximum rated sampling frequency, sine wave input clock, 1.5VPP differential clock amplitude, 50% clock duty cycle, -1dBFS differential analog input, low-latency mode, DDR LVDS output interface, and 32k-point FFT, unless otherwise noted. Note that after reset, the device is in 0dB gain mode

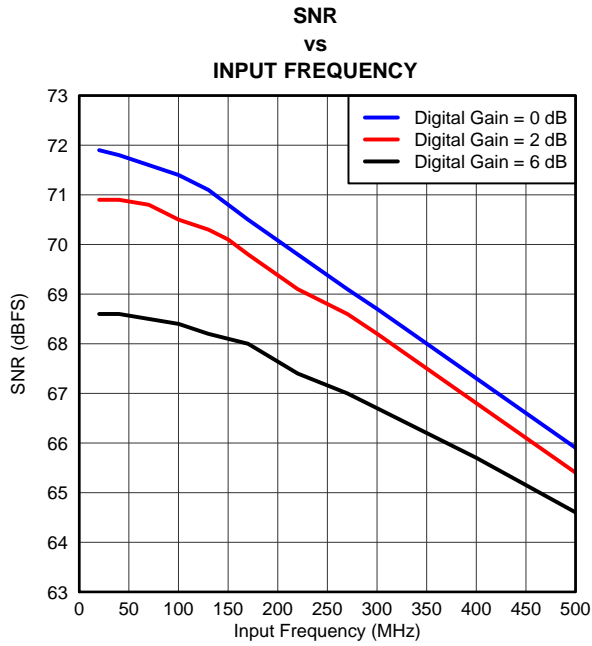

Figure 20.

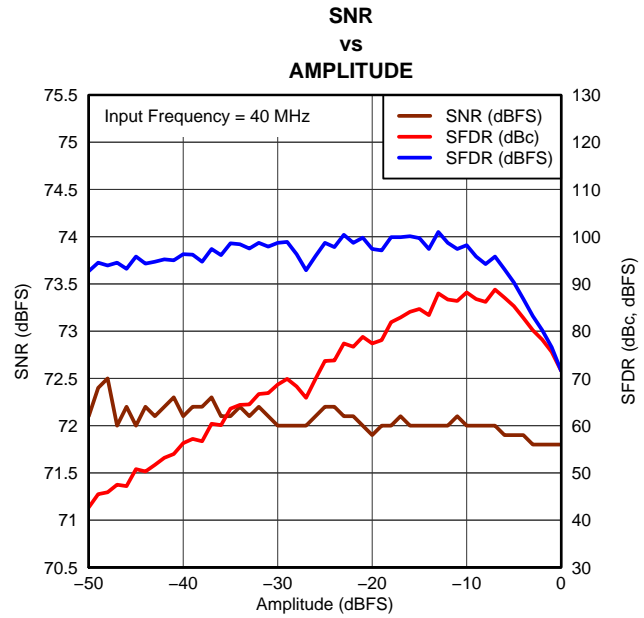

Figure 21.

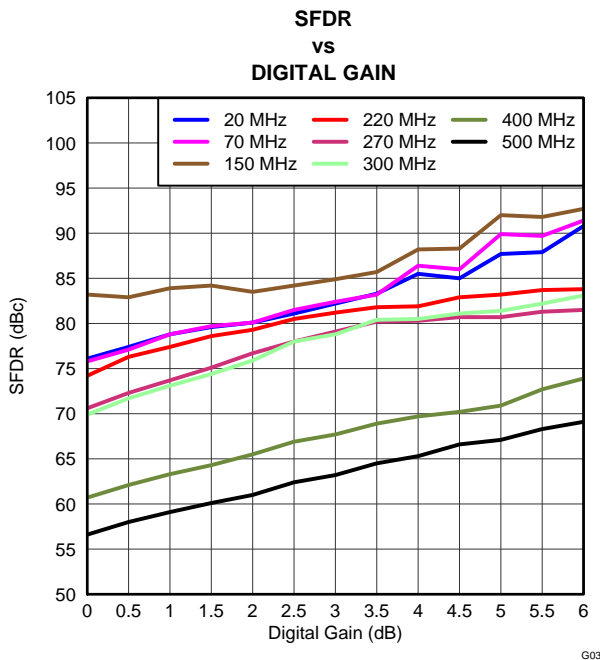

Figure 22.

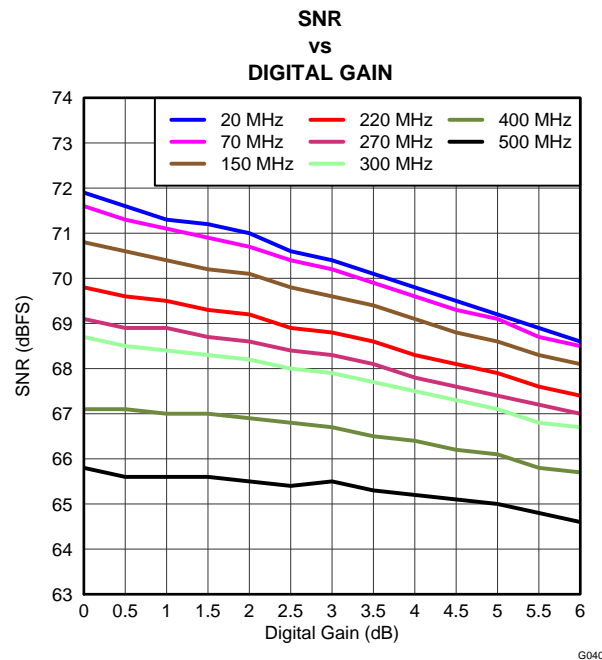

Figure 23.

TYPICAL CHARACTERISTICS (continued)

At +25°C, AVDD = 1.8V, AVDD_3V = 3.3V, DRVDD = 1.8V, maximum rated sampling frequency, sine wave input clock, 1.5VPP differential clock amplitude, 50% clock duty cycle, -1dBFS differential analog input, low-latency mode, DDR LVDS output interface, and 32k-point FFT, unless otherwise noted. Note that after reset, the device is in 0dB gain mode

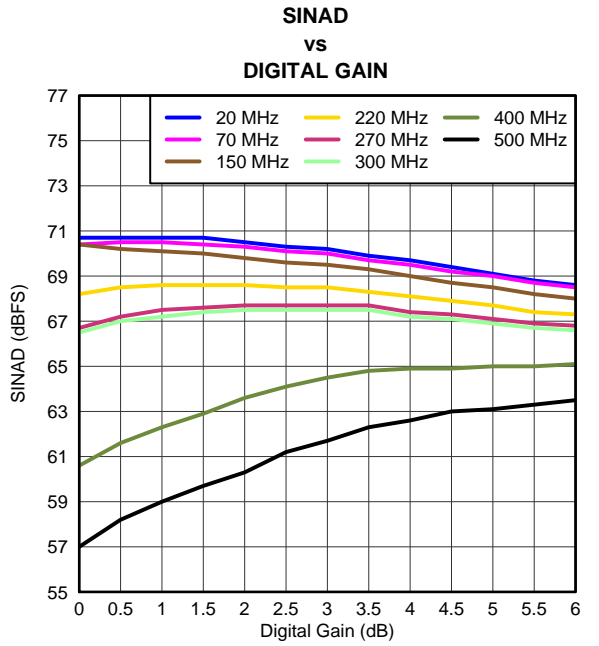

Figure 24.

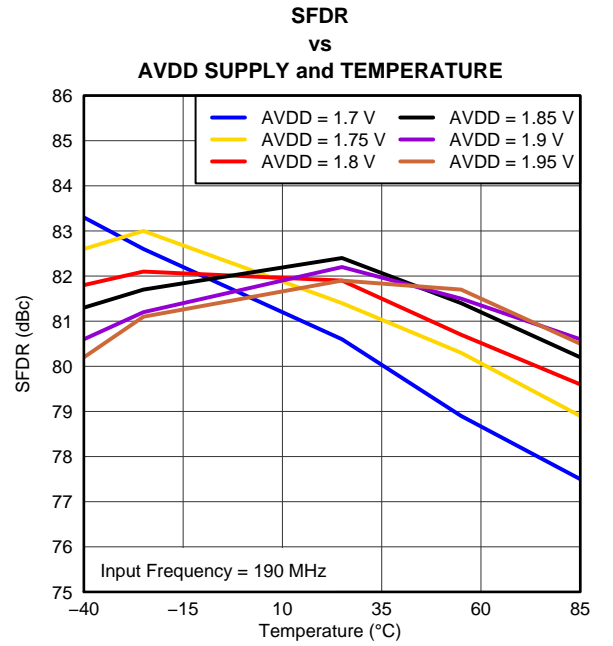

Figure 25.

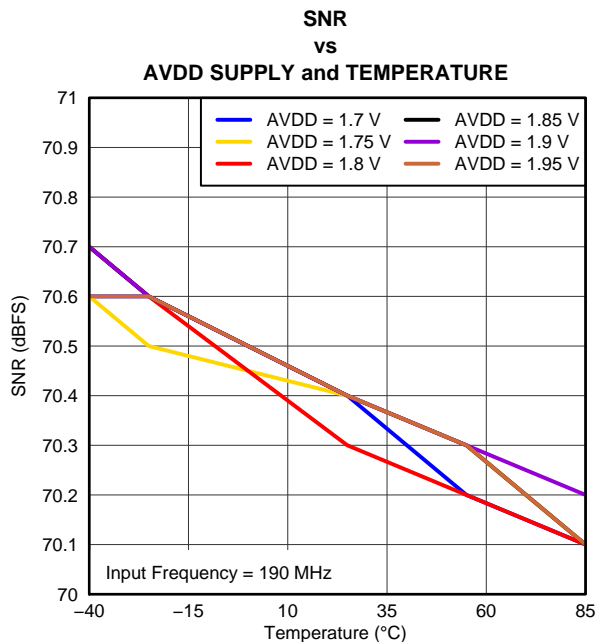

Figure 26.

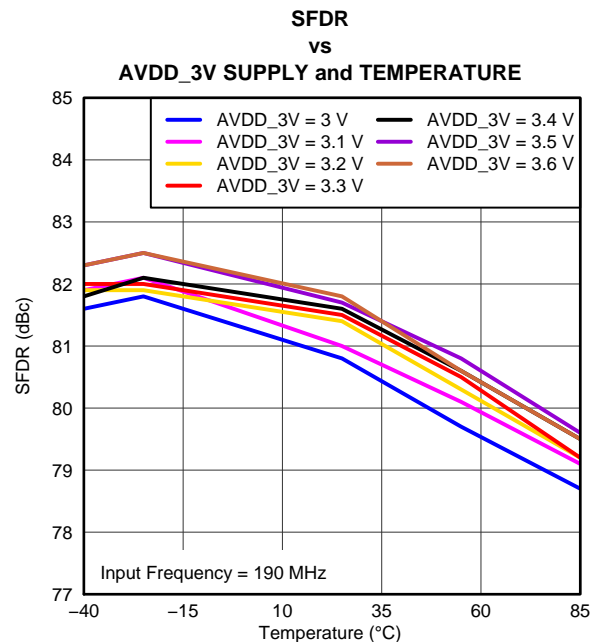

Figure 27.

TYPICAL CHARACTERISTICS (continued)

At +25°C, AVDD = 1.8V, AVDD_3V = 3.3V, DRVDD = 1.8V, maximum rated sampling frequency, sine wave input clock, 1.5VPP differential clock amplitude, 50% clock duty cycle, -1dBFS differential analog input, low-latency mode, DDR LVDS output interface, and 32k-point FFT, unless otherwise noted. Note that after reset, the device is in 0dB gain mode

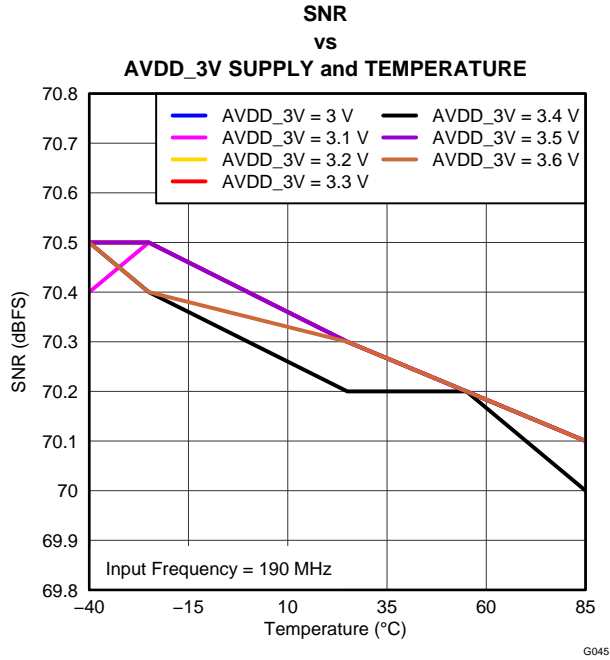

Figure 28.

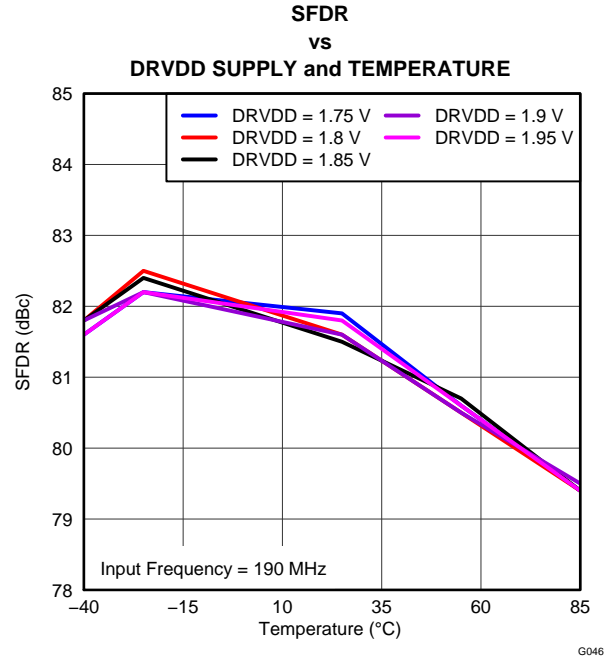

Figure 29.

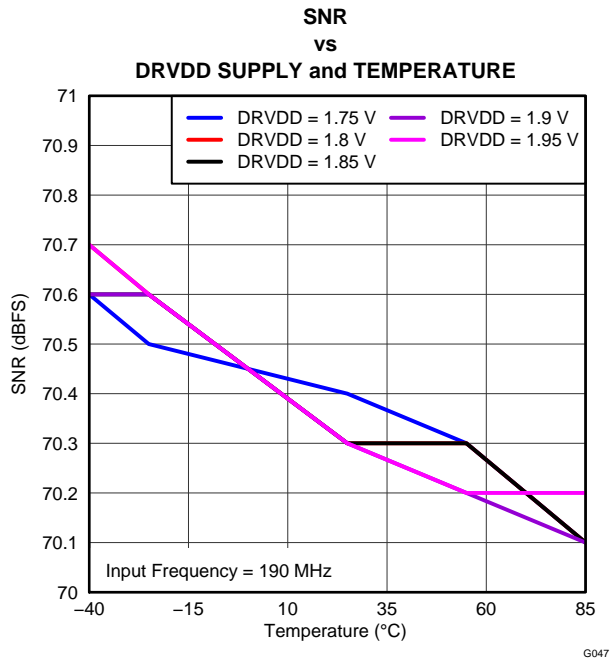

Figure 30.

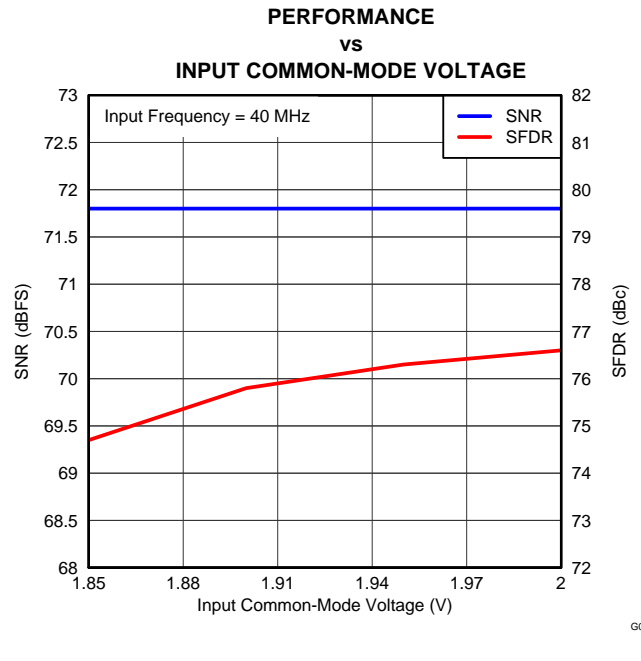

Figure 31.

TYPICAL CHARACTERISTICS (continued)

At +25°C, AVDD = 1.8V, AVDD_3V = 3.3V, DRVDD = 1.8V, maximum rated sampling frequency, sine wave input clock, 1.5VPP differential clock amplitude, 50% clock duty cycle, -1dBFS differential analog input, low-latency mode, DDR LVDS output interface, and 32k-point FFT, unless otherwise noted. Note that after reset, the device is in 0dB gain mode

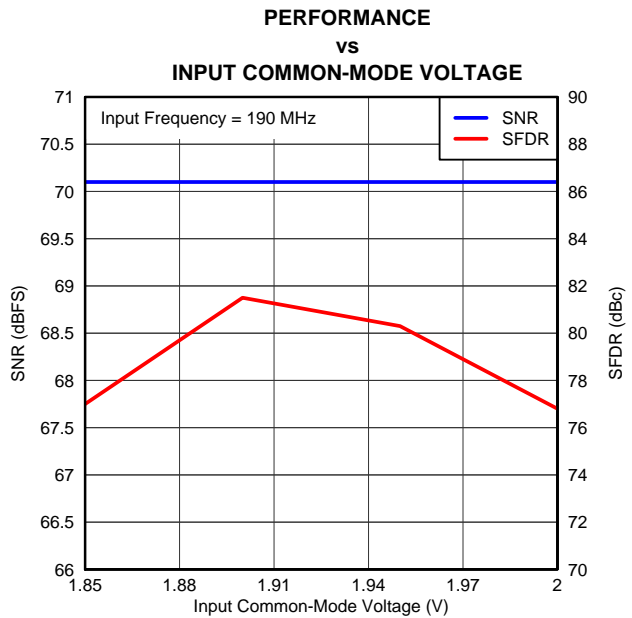

Figure 32.

G049

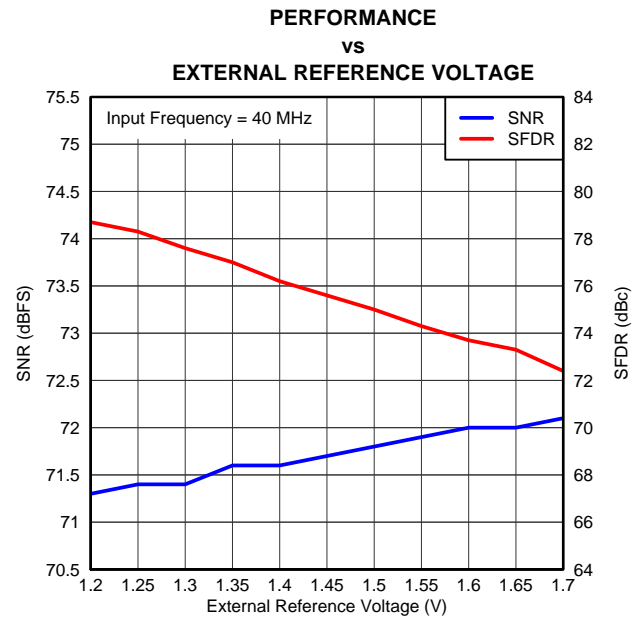

Figure 33.

G050

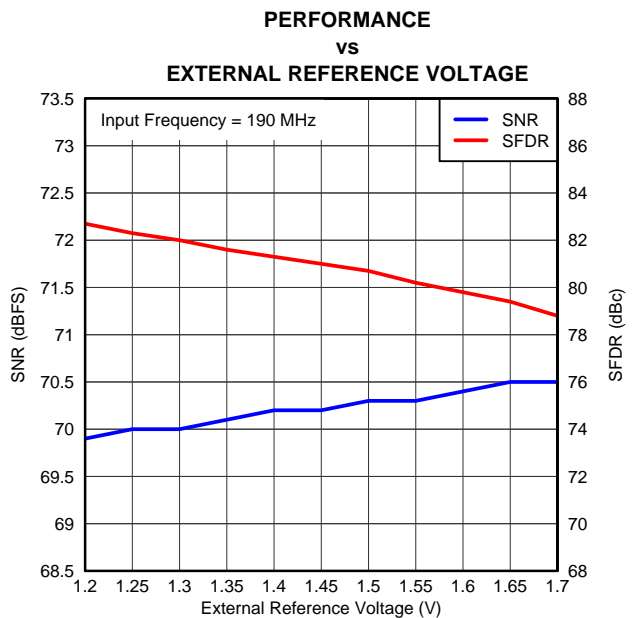

Figure 34.

G051

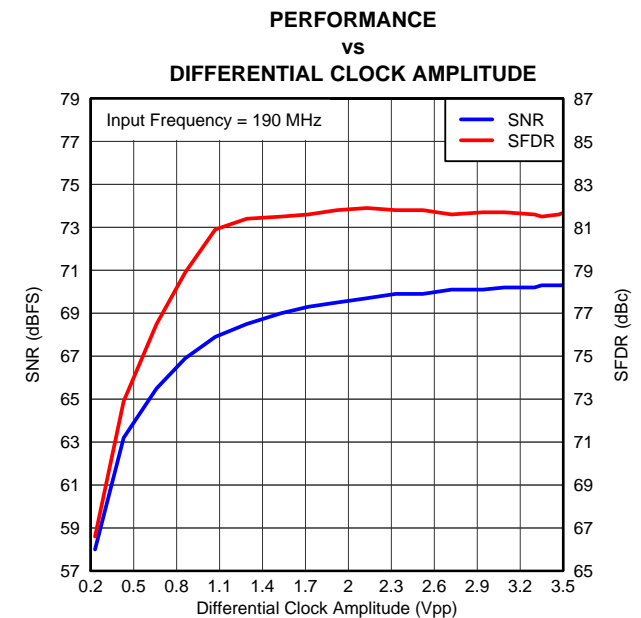

Figure 35.

G052

TYPICAL CHARACTERISTICS (continued)

At +25°C, AVDD = 1.8V, AVDD_3V = 3.3V, DRVDD = 1.8V, maximum rated sampling frequency, sine wave input clock, 1.5VPP differential clock amplitude, 50% clock duty cycle, -1dBFS differential analog input, low-latency mode, DDR LVDS output interface, and 32k-point FFT, unless otherwise noted. Note that after reset, the device is in 0dB gain mode

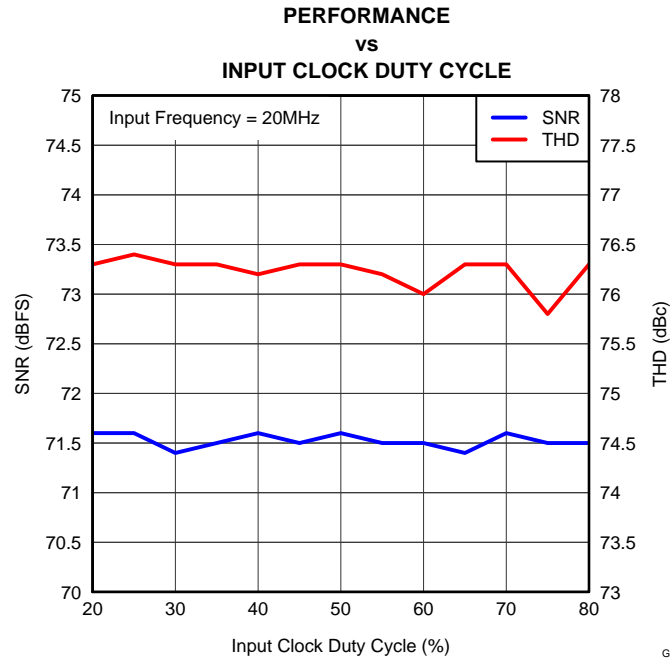

Figure 36.

TYPICAL CHARACTERISTICS: COMMON

At +25°C, AVDD = 1.8V, AVDD_3V = 3.3V, DRVDD = 1.8V, maximum rated sampling frequency, sine wave input clock, 1.5VPP differential clock amplitude, 50% clock duty cycle, -1dBFS differential analog input, low-latency mode, DDR LVDS output interface, and 32k-point FFT, unless otherwise noted. Note that after reset, the device is in 0dB gain mode

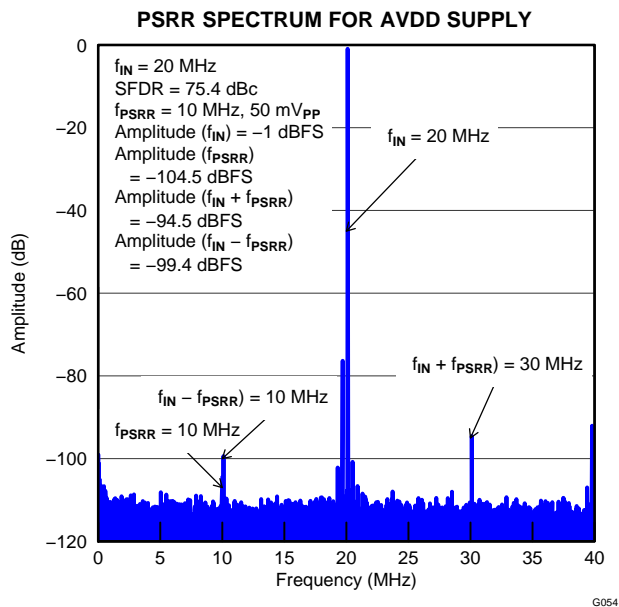

Figure 37.

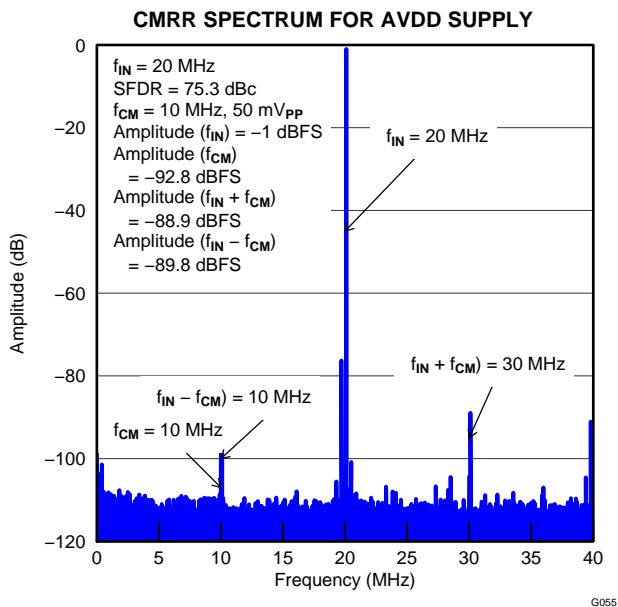

Figure 38.

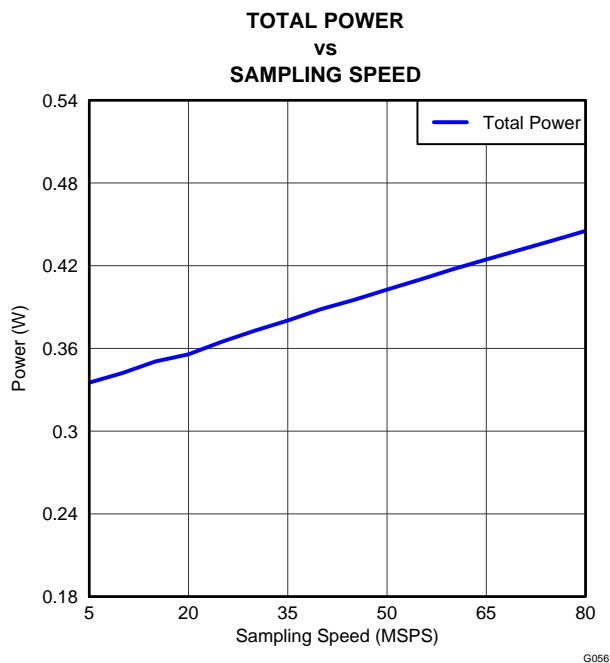

Figure 39.

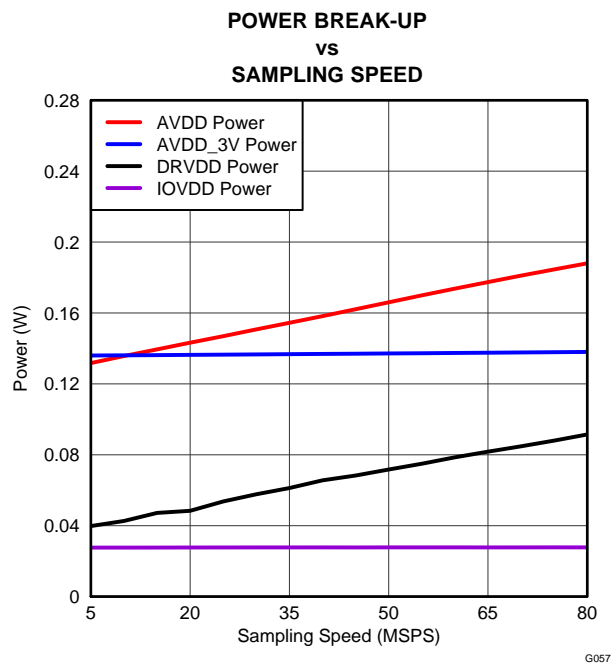

Figure 40.

TYPICAL CHARACTERISTICS: COMMON (continued)

At +25°C, AVDD = 1.8V, AVDD_3V = 3.3V, DRVDD = 1.8V, maximum rated sampling frequency, sine wave input clock, 1.5VPP differential clock amplitude, 50% clock duty cycle, -1dBFS differential analog input, low-latency mode, DDR LVDS output interface, and 32k-point FFT, unless otherwise noted. Note that after reset, the device is in 0dB gain mode

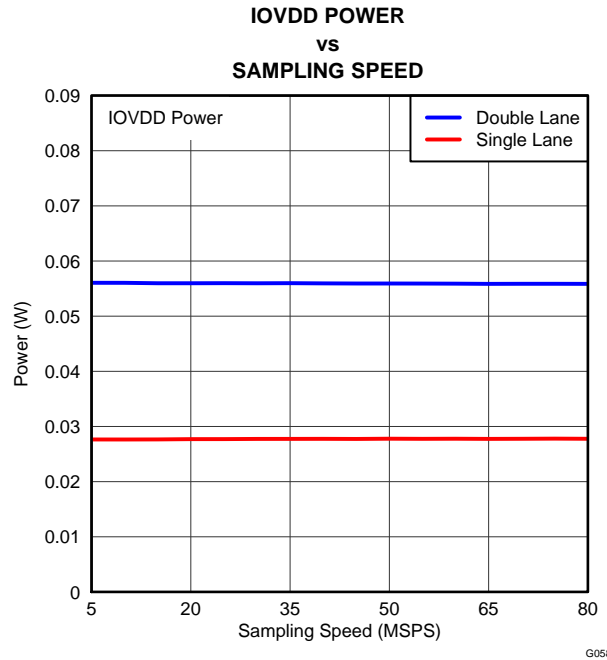
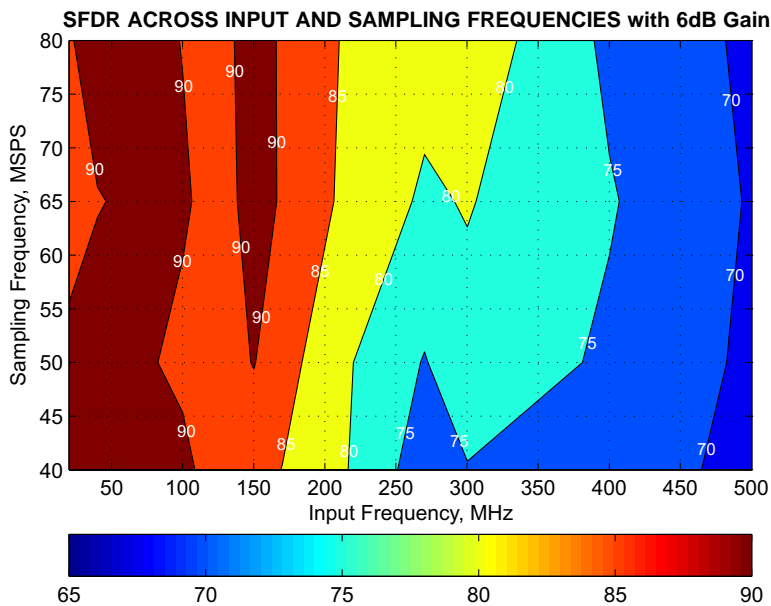
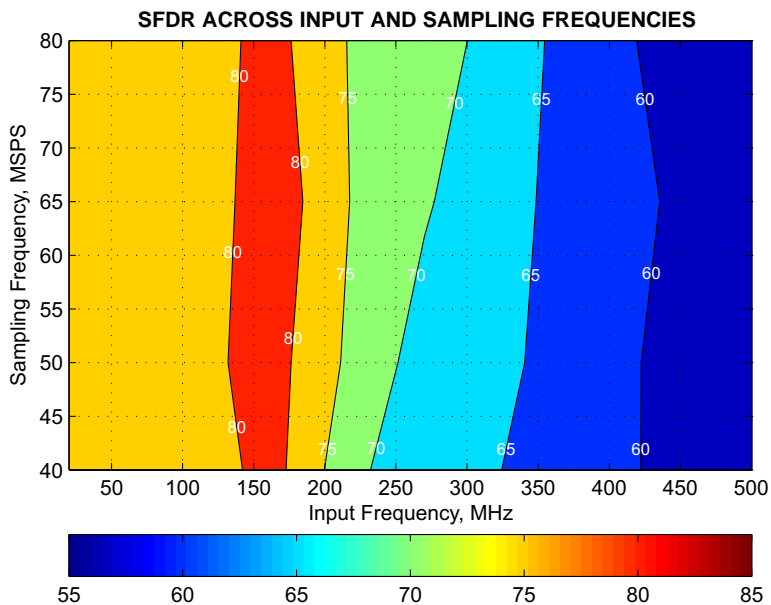

Figure 41.

TYPICAL CHARACTERISTICS: CONTOUR

At +25°C, AVDD = 1.8V, AVDD_3V = 3.3V, DRVDD = 1.8V, maximum rated sampling frequency, sine wave input clock, 1.5VPP differential clock amplitude, 50% clock duty cycle, -1dBFS differential analog input, low-latency mode, DDR LVDS output interface, and 32k-point FFT, unless otherwise noted. Note that after reset, the device is in 0dB gain mode



TYPICAL CHARACTERISTICS: CONTOUR (continued)

At +25°C, AVDD = 1.8V, AVDD_3V = 3.3V, DRVDD = 1.8V, maximum rated sampling frequency, sine wave input clock, 1.5VPP differential clock amplitude, 50% clock duty cycle, -1dBFS differential analog input, low-latency mode, DDR LVDS output interface, and 32k-point FFT, unless otherwise noted. Note that after reset, the device is in 0dB gain mode

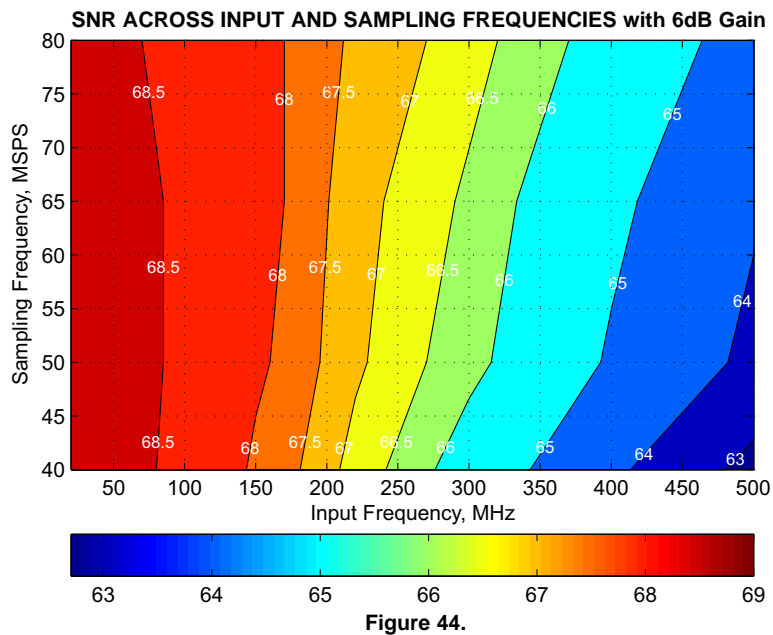
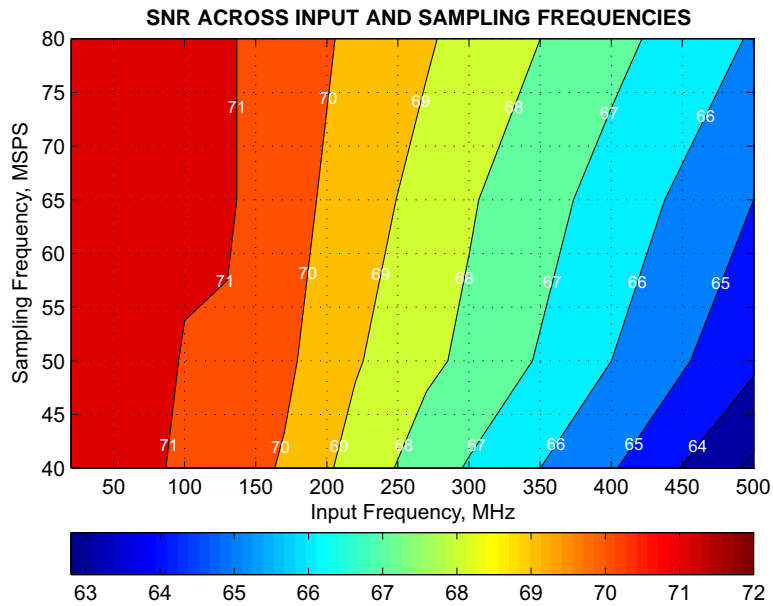

APPLICATION INFORMATION

THEORY OF OPERATION

The ADS61JB23 is a family of buffered analog input and ultralow power ADCs with maximum sampling rates up to 80MSPS. The conversion process is initiated by a rising edge of the external input clock and the analog input signal is sampled. The sampled signal is sequentially converted by a series of small resolution stages, with the outputs combined in a digital correction logic block. At every clock edge the sample propagates through the pipeline, resulting in a data latency of 21 clock cycles. The output is available as 12-bit data, coded in either straight offset binary or binary twos complement format, with JESD207A interface in CML logic levels.

ANALOG INPUTS

The analog input pins have analog buffers (running off the AVDD3V supply) that internally drive the differential sampling circuit. As a result of the analog buffer, the input pins present high input impedance to the external driving source (10kΩ dc resistance and 2pF input capacitance). The buffer helps to isolate the external driving source from the switching currents of the sampling circuit. This buffering makes it easy to drive the buffered inputs compared to an ADC without the buffer.

The input common-mode is set internally using a 5kΩ resistor from each input pin to 1.95V, so the input signal can be ac-coupled to the pins. Each input pin (INP, INM) must swing symmetrically between (VCM + 0.5V) and (VCM – 0.5V), resulting in a 2V_{PP} differential input swing.

The input sampling circuit has a high 3dB bandwidth that extends up to 450 MHz (measured from the input pins to the sampled voltage). Figure 45 shows an equivalent circuit for the analog input.

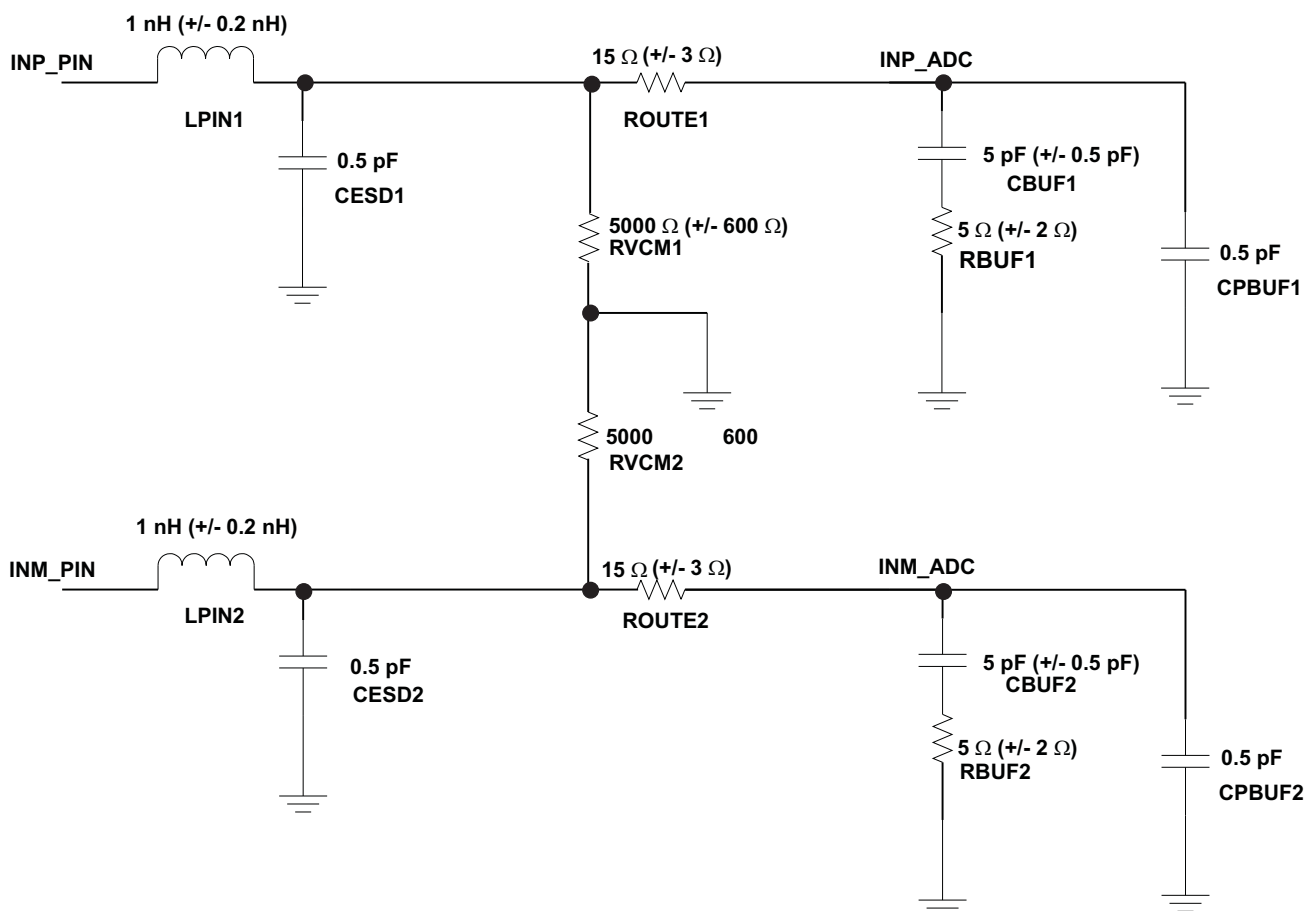
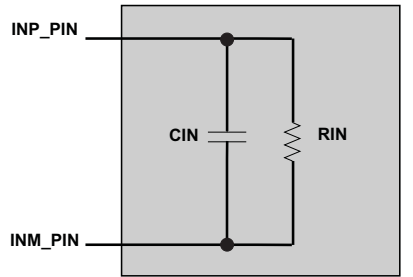

Figure 45. Equivalent Circuit

DRIVE CIRCUIT REQUIREMENTS

For optimum performance, the analog inputs must be driven differentially. This technique improves the common-mode noise immunity and even-order harmonic rejection. A small resistor (5Ω) in series with each input pin is recommended to damp out ringing caused by package parasitics.

and show the differential impedance ($Z_{IN} = R_{IN} \parallel C_{IN}$) seen by looking into the ADC input pins. The presence of the analog input buffer results in an almost constant input capacitance up to 1GHz.



RIN and CIN change with frequency

At frequency F :
 Real part of input impedance (input resistance) = RIN
 Imaginary part of input impedance = $1/(2 \cdot \pi \cdot F \cdot C_{IN})$
 Input capacitance = CIN

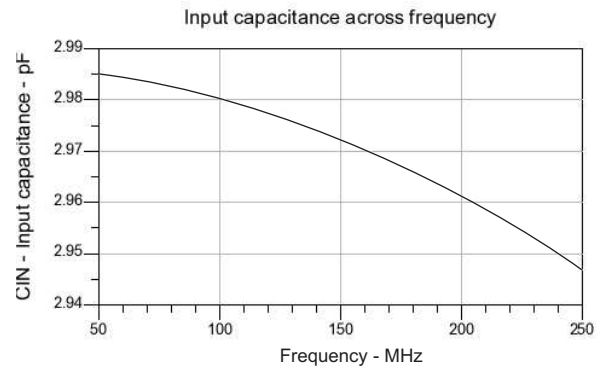
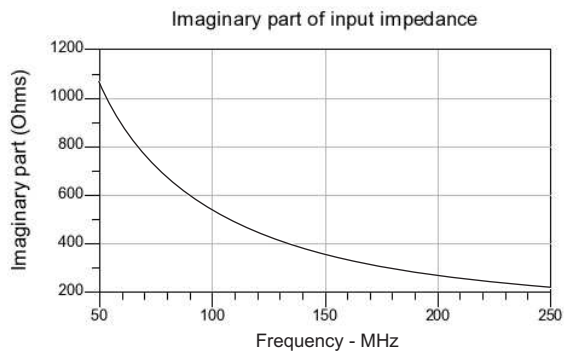
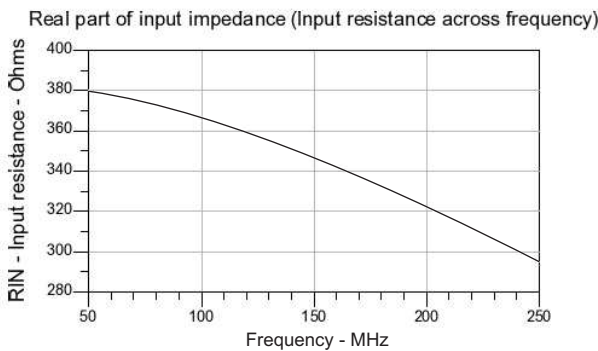

EXAMPLE DRIVING CIRCUITS

Two example driving circuit configurations are shown in [Figure 46](#) and [Figure 47](#)—one optimized for low input frequencies and the other optimized for high input frequencies.

The presence of internal analog buffers makes the ADS61JB23 simple to drive by absorbing kick-back noise of ADC. The mismatch in the transformer parasitic capacitance (between the windings) results in degraded even-order harmonic performance. Connecting two identical RF transformers back-to-back helps minimize this mismatch and good performance is obtained in input frequency range of interest.

The drive circuit for low input frequencies (<200MHz) in [Figure 46](#) uses two back to back connected ADT1-1 transformers terminated by 50Ω near the ADC side.

An additional termination resistor pair may be required between the two transformers to improve even order harmonic performance as shown in drive circuit for high input frequencies (>200MHz) in [Figure 47](#). The center point of this termination is connected to ground to improve the balance between the P (positive) and M (negative) sides. The example circuit uses two back to back connected ADTL2-18 transformers with 200Ω termination between them and 100Ω at secondary of second transformer to obtain an effective 50Ω (for a 50Ω source impedance). The ac-coupling capacitors allow the analog inputs to self-bias around the required common-mode voltage.

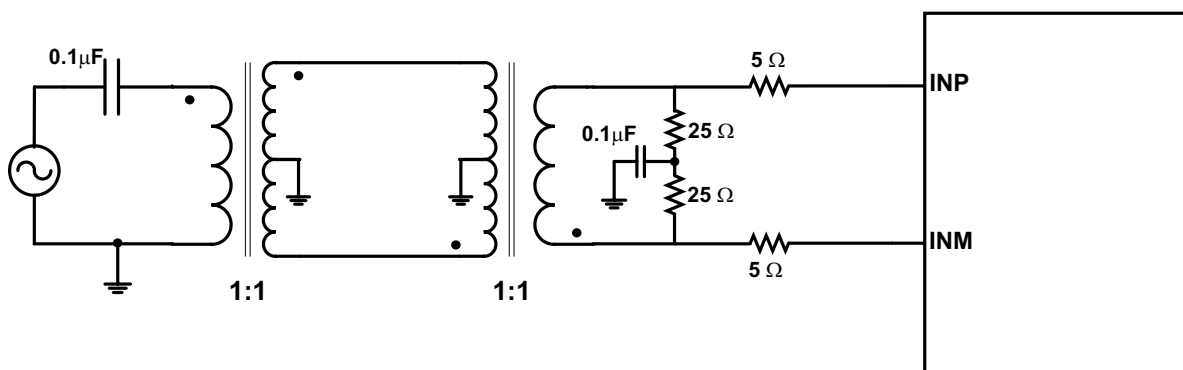

Figure 46. Drive Circuit with Low Bandwidth (for Low Input Frequencies)

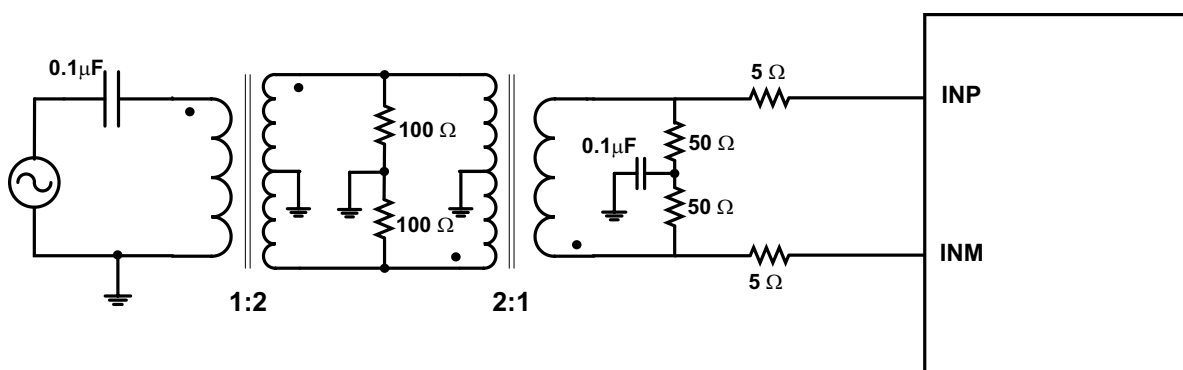
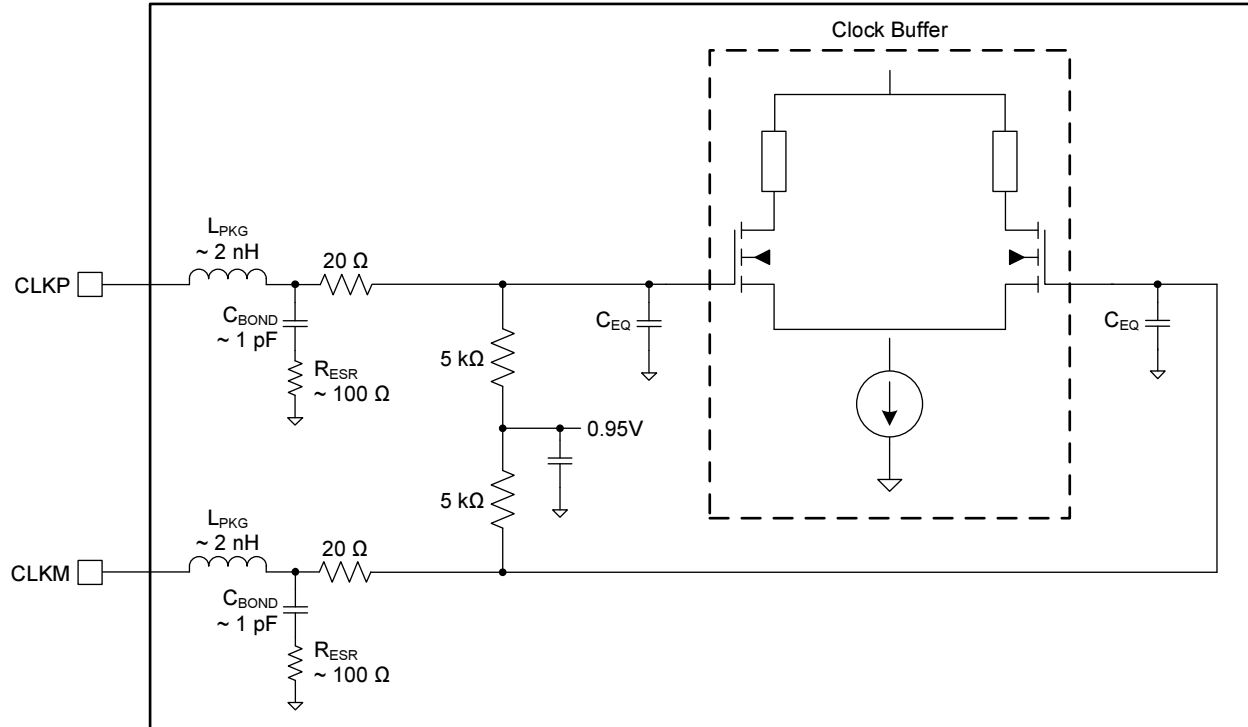

Figure 47. Drive Circuit with High Bandwidth (for High Input Frequencies)

CLOCK INPUT

The ADS61JB23 clock inputs can be driven differentially by sine, LVPECL, or LVDS source with little or no difference in performance between them. The common-mode voltage of the clock inputs is set to 0.95V using internal 5kΩ resistors as shown in Figure 48. This setting allows the use of transformer-coupled drive circuits for sine-wave clock or ac-coupling for LVPECL and LVDS clock sources (see Figure 49, Figure 50, and Figure 51).



Note: C_{EQ} is 1pF to 3pF and is the equivalent input capacitance of the clock buffer.

Figure 48. Internal Clock Buffer

For best performance, the clock inputs must be driven differentially, thereby reducing susceptibility to common-mode noise. It is recommended to keep differential voltage between clock inputs less than 1.8VPP to get best performance. For high input frequency sampling, it is recommended to use a clock source with very low jitter. Band-pass filtering of the clock source can help reduce the effects of jitter. There is no change in performance with a non-50% duty cycle clock input.

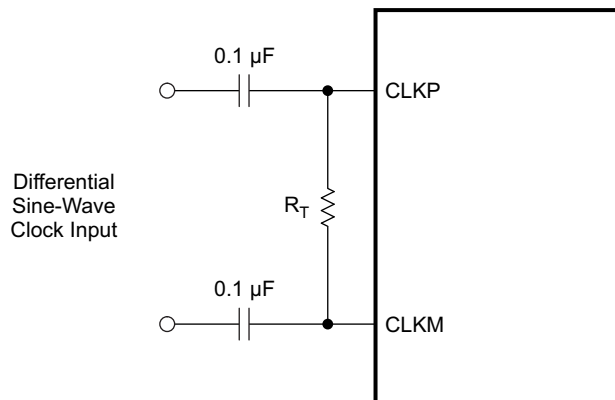

Figure 49. Differential Sine-Wave Clock Driving Circuit

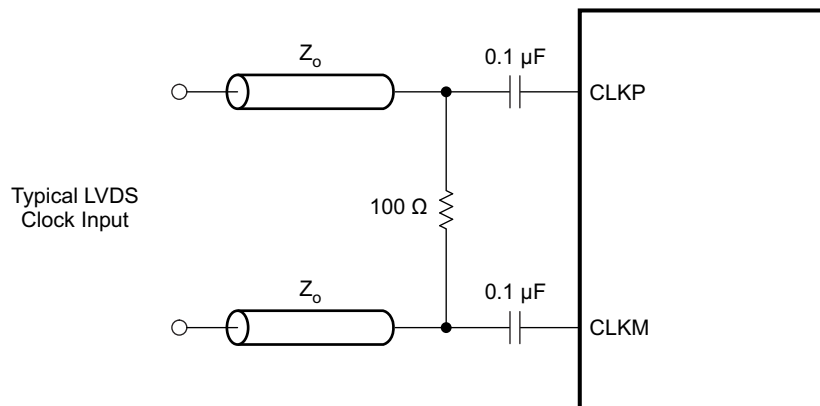

Figure 50. LVDS Clock Driving Circuit

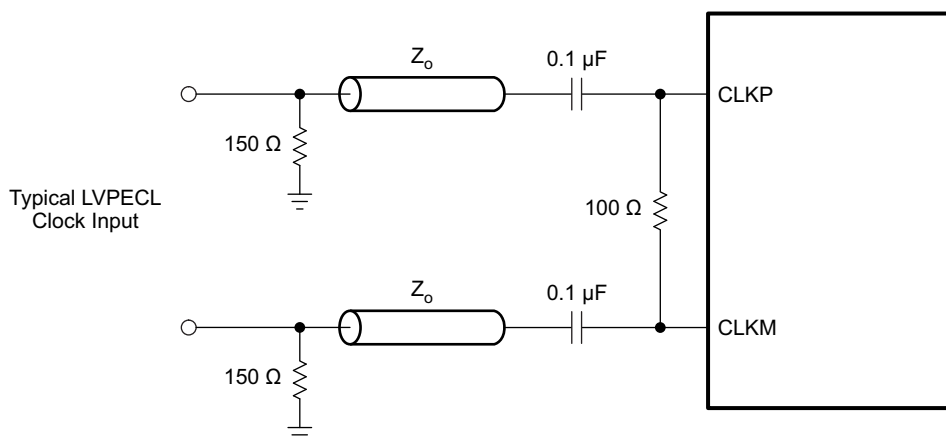

Figure 51. LVPECL Clock Driving Circuit

FINE GAIN CONTROL

The ADS61JB23 includes gain settings that can be used to get improved SFDR performance (compared to no gain). The gain is programmable from 0dB to 6dB (in 0.5dB steps). For each gain setting, the analog input full-scale range scales proportionally, as shown in [Table 9](#).

The SFDR improvement is achieved at the expense of SNR; for each gain setting, the SNR degrades about 0.5dB. The SNR degradation is less at high input frequencies. As a result, the fine gain is very useful at high input frequencies as the SFDR improvement is significant with marginal degradation in SNR.

So, the fine gain can be used to trade-off between SFDR and SNR. Note that the default gain after reset is 0dB.

Table 9. Full-scale Range Across Gains

FINE_GAIN<3:0>	GAIN, dB	TYPE	FULL-SCALE, Vpp
0000	0	Fine gain, programmable Default after reset	2.00
0001	0.5		1.89
0010	1		1.78
0011	1.5		1.68
0100	2		1.59
0101	2.5		1.5
0110	3		1.42
0111	3.5		1.34
1000	4		1.26
1001	4.5		1.19
1010	5		1.12
1011	5.5		1.06
1100	6		1.00
1101	Do not use		
1110	Do not use		
1111	Do not use		

SIGNAL POWER ESTIMATION

The ADS61JB23 includes a power estimation circuit that can be used to obtain a coarse power estimate (accurate to within a dB) of the input signal averaged over a programmable number of samples. The power estimate can be made available on pins DETECT<3:0> by enabling the bit EN_PWR_EST. The states of bits DETECT<3:0> maps to the input signal power is shown in [Table 10](#).

Table 10. State of DETECT<3:0> Versus Input Signal Power

INPUT SIGNAL POWER RANGE IN dBfs	DETECT<3:0>	INPUT SIGNAL POWER RANGE IN dBfs	DETECT<3:0>
–Inf to –12.5	0001	–6.5 to –5.5	1000
–12.5 to –11.5	0010	–5.5 to –4.5	1001
–11.5 to –10.5	0011	–4.5 to –3.5	1010
–10.5 to –9.5	0100	–3.5 to –2.5	1011
–9.5 to –8.5	0101	–2.5 to –1.5	1100
–8.5 to –7.5	0110	–1.5 to 0	1101
–7.5 to –6.5	0111	0 to +1	1110

The number of samples used for computing the average power is set by SAMPLES_PWR_EST<2:0> as shown in [Table 11](#).

Table 11. Number of Samples Used for Power Estimation

SAMPLES_PWR_EST<2:0>	NUMBER OF SAMPLES
000	1K
001	2K
010	4K
011	8K
100	16K

DEFINITION OF SPECIFICATIONS

Analog Bandwidth – The analog input frequency at which the power of the fundamental is reduced by 3 dB with respect to the low frequency value.

Aperture Delay – The delay in time between the rising edge of the input sampling clock and the actual time at which the sampling occurs. This delay will be different across channels. The maximum variation is specified as aperture delay variation (channel-channel).

Aperture Uncertainty (Jitter) – The sample-to-sample variation in aperture delay.

Clock Pulse Width/Duty Cycle – The duty cycle of a clock signal is the ratio of the time the clock signal remains at a logic high (clock pulse width) to the period of the clock signal. Duty cycle is typically expressed as a percentage. A perfect differential sine-wave clock results in a 50% duty cycle.

Maximum Conversion Rate – The maximum sampling rate at which certified operation is given. All parametric testing is performed at this sampling rate unless otherwise noted.

Minimum Conversion Rate – The minimum sampling rate at which the ADC functions.

Differential Nonlinearity (DNL) – An ideal ADC exhibits code transitions at analog input values spaced exactly 1 LSB apart. The DNL is the deviation of any single step from this ideal value, measured in units of LSBs.

Integral Nonlinearity (INL) – The INL is the deviation of the ADC's transfer function from a best fit line determined by a least squares curve fit of that transfer function, measured in units of LSBs.

Gain Error – Gain error is the deviation of the ADC's actual input full-scale range from its ideal value. The gain error is given as a percentage of the ideal input full-scale range. Gain error has two components: error due to reference inaccuracy and error due to the channel. Both these errors are specified independently as E_{GREF} and E_{GCHAN} .

To a first order approximation, the total gain error will be $E_{TOTAL} \sim E_{GREF} + E_{GCHAN}$.

For example, if $E_{TOTAL} = \pm 0.5\%$, the full-scale input varies from $(1 - 0.5/100) \times FS_{ideal}$ to $(1 + 0.5/100) \times FS_{ideal}$.

Offset Error – The offset error is the difference, given in number of LSBs, between the ADC's actual average idle channel output code and the ideal average idle channel output code. This quantity is often mapped into mV.

Temperature Drift – The temperature drift coefficient (with respect to gain error and offset error) specifies the change per degree Celsius of the parameter from T_{MIN} to T_{MAX} . It is calculated by dividing the maximum deviation of the parameter across the T_{MIN} to T_{MAX} range by the difference $T_{MAX} - T_{MIN}$.

Signal-to-Noise Ratio – SNR is the ratio of the power of the fundamental (PS) to the noise floor power (PN), excluding the power at DC and the first nine harmonics.

$$SNR = 10 \log_{10} \frac{P_S}{P_N} \quad (1)$$

SNR is either given in units of dBc (dB to carrier) when the absolute power of the fundamental is used as the reference, or dBFS (dB to full scale) when the power of the fundamental is extrapolated to the converter's full-scale range.

Signal-to-Noise and Distortion (SINAD) – SINAD is the ratio of the power of the fundamental (P_S) to the power of all the other spectral components including noise (P_N) and distortion (P_D), but excluding dc.

$$SINAD = 10 \log_{10} \frac{P_S}{P_N + P_D} \quad (2)$$

SINAD is either given in units of dBc (dB to carrier) when the absolute power of the fundamental is used as the reference, or dBFS (dB to full scale) when the power of the fundamental is extrapolated to the converter's full-scale range.

Effective Number of Bits (ENOB) – The ENOB is a measure of the converter performance as compared to the theoretical limit based on quantization noise.

$$\text{ENOB} = \frac{\text{SINAD} - 1.76}{6.02} \quad (3)$$

Total Harmonic Distortion (THD) – THD is the ratio of the power of the fundamental (P_S) to the power of the first nine harmonics (P_D).

$$\text{THD} = 10 \log^{10} \frac{P_S}{P_N} \quad (4)$$

THD is typically given in units of dBc (dB to carrier).

Spurious-Free Dynamic Range (SFDR) – The ratio of the power of the fundamental to the highest other spectral component (either spur or harmonic). SFDR is typically given in units of dBc (dB to carrier).

Two-Tone Intermodulation Distortion – IMD3 is the ratio of the power of the fundamental (at frequencies f_1 and f_2) to the power of the worst spectral component at either frequency $2f_1 - f_2$ or $2f_2 - f_1$. IMD3 is either given in units of dBc (dB to carrier) when the absolute power of the fundamental is used as the reference, or dBFS (dB to full scale) when the power of the fundamental is extrapolated to the converter's full-scale range.

DC Power Supply Rejection Ratio (DC PSRR) – The DC PSRR is the ratio of the change in offset error to a change in analog supply voltage. The DC PSRR is typically given in units of mV/V.

AC Power Supply Rejection Ratio (AC PSRR) – AC PSRR is the measure of rejection of variations in the supply voltage by the ADC. If ΔV_{SUP} is the change in supply voltage and ΔV_{OUT} is the resultant change of the ADC output code (referred to the input), then

$$\text{PSRR} = 20 \log^{10} \frac{\Delta V_{OUT}}{\Delta V_{SUP}} \quad (\text{Expressed in dBc}) \quad (5)$$

Voltage Overload Recovery – The number of clock cycles taken to recover to less than 1% error after an overload on the analog inputs. This is tested by separately applying a sine wave signal with 6dB positive and negative overload. The deviation of the first few samples after the overload (from their expected values) is noted.

Common Mode Rejection Ratio (CMRR) – CMRR is the measure of rejection of variation in the analog input common-mode by the ADC. If ΔV_{cm_in} is the change in the common-mode voltage of the input pins and ΔV_{OUT} is the resultant change of the ADC output code (referred to the input), then

$$\text{CMRR} = 20 \log^{10} \frac{\Delta V_{OUT}}{\Delta V_{CM}} \quad (\text{Expressed in dBc}) \quad (6)$$

Cross-Talk (only for multi-channel ADC) – This is a measure of the internal coupling of a signal from adjacent channel into the channel of interest. It is specified separately for coupling from the immediate neighboring channel (near-channel) and for coupling from channel across the package (far-channel). It is usually measured by applying a full-scale signal in the adjacent channel. Cross-talk is the ratio of the power of the coupling signal (as measured at the output of the channel of interest) to the power of the signal applied at the adjacent channel input. It is typically expressed in dBc.

PACKAGING INFORMATION

Orderable Device	Status (1)	Package Type	Package Drawing	Pins	Package Qty	Eco Plan (2)	Lead finish/ Ball material (6)	MSL Peak Temp (3)	Op Temp (°C)	Device Marking (4/5)	Samples
ADS61JB23IRHAR	ACTIVE	VQFN	RHA	40	2500	RoHS & Green	NIPDAUAG	Level-3-260C-168 HR	-40 to 85	61JB23	Samples
ADS61JB23IRHAT	ACTIVE	VQFN	RHA	40	250	RoHS & Green	NIPDAUAG	Level-3-260C-168 HR	-40 to 85	61JB23	Samples

(1) The marketing status values are defined as follows:

ACTIVE: Product device recommended for new designs.

LIFEBUY: TI has announced that the device will be discontinued, and a lifetime-buy period is in effect.

NRND: Not recommended for new designs. Device is in production to support existing customers, but TI does not recommend using this part in a new design.

PREVIEW: Device has been announced but is not in production. Samples may or may not be available.

OBSOLETE: TI has discontinued the production of the device.

(2) **RoHS:** TI defines "RoHS" to mean semiconductor products that are compliant with the current EU RoHS requirements for all 10 RoHS substances, including the requirement that RoHS substance do not exceed 0.1% by weight in homogeneous materials. Where designed to be soldered at high temperatures, "RoHS" products are suitable for use in specified lead-free processes. TI may reference these types of products as "Pb-Free".

RoHS Exempt: TI defines "RoHS Exempt" to mean products that contain lead but are compliant with EU RoHS pursuant to a specific EU RoHS exemption.

Green: TI defines "Green" to mean the content of Chlorine (Cl) and Bromine (Br) based flame retardants meet JS709B low halogen requirements of <=1000ppm threshold. Antimony trioxide based flame retardants must also meet the <=1000ppm threshold requirement.

(3) MSL, Peak Temp. - The Moisture Sensitivity Level rating according to the JEDEC industry standard classifications, and peak solder temperature.

(4) There may be additional marking, which relates to the logo, the lot trace code information, or the environmental category on the device.

(5) Multiple Device Markings will be inside parentheses. Only one Device Marking contained in parentheses and separated by a "~" will appear on a device. If a line is indented then it is a continuation of the previous line and the two combined represent the entire Device Marking for that device.

(6) Lead finish/Ball material - Orderable Devices may have multiple material finish options. Finish options are separated by a vertical ruled line. Lead finish/Ball material values may wrap to two lines if the finish value exceeds the maximum column width.

Important Information and Disclaimer:The information provided on this page represents TI's knowledge and belief as of the date that it is provided. TI bases its knowledge and belief on information provided by third parties, and makes no representation or warranty as to the accuracy of such information. Efforts are underway to better integrate information from third parties. TI has taken and continues to take reasonable steps to provide representative and accurate information but may not have conducted destructive testing or chemical analysis on incoming materials and chemicals. TI and TI suppliers consider certain information to be proprietary, and thus CAS numbers and other limited information may not be available for release.

In no event shall TI's liability arising out of such information exceed the total purchase price of the TI part(s) at issue in this document sold by TI to Customer on an annual basis.

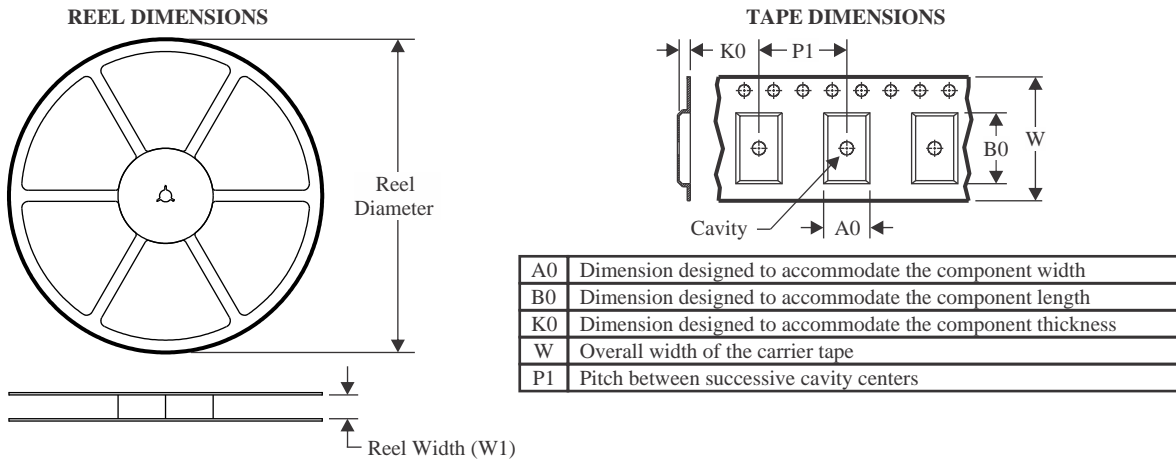
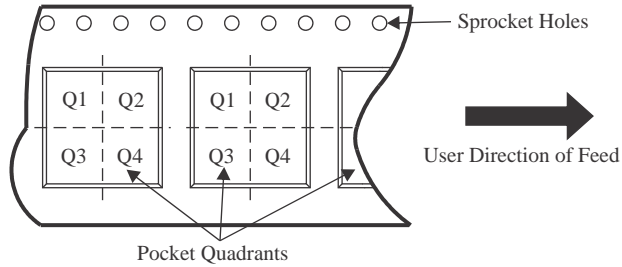
TAPE AND REEL INFORMATION

QUADRANT ASSIGNMENTS FOR PIN 1 ORIENTATION IN TAPE

*All dimensions are nominal

Device	Package Type	Package Drawing	Pins	SPQ	Reel Diameter (mm)	Reel Width W1 (mm)	A0 (mm)	B0 (mm)	K0 (mm)	P1 (mm)	W (mm)	Pin1 Quadrant
ADS61JB23IRHAR	VQFN	RHA	40	2500	330.0	16.4	6.3	6.3	1.5	12.0	16.0	Q2

TAPE AND REEL BOX DIMENSIONS

*All dimensions are nominal

Device	Package Type	Package Drawing	Pins	SPQ	Length (mm)	Width (mm)	Height (mm)
ADS61JB23IRHAR	VQFN	RHA	40	2500	350.0	350.0	43.0

GENERIC PACKAGE VIEW

RHA 40

VQFN - 1 mm max height

6 x 6, 0.5 mm pitch

PLASTIC QUAD FLATPACK - NO LEAD

This image is a representation of the package family, actual package may vary.
Refer to the product data sheet for package details.

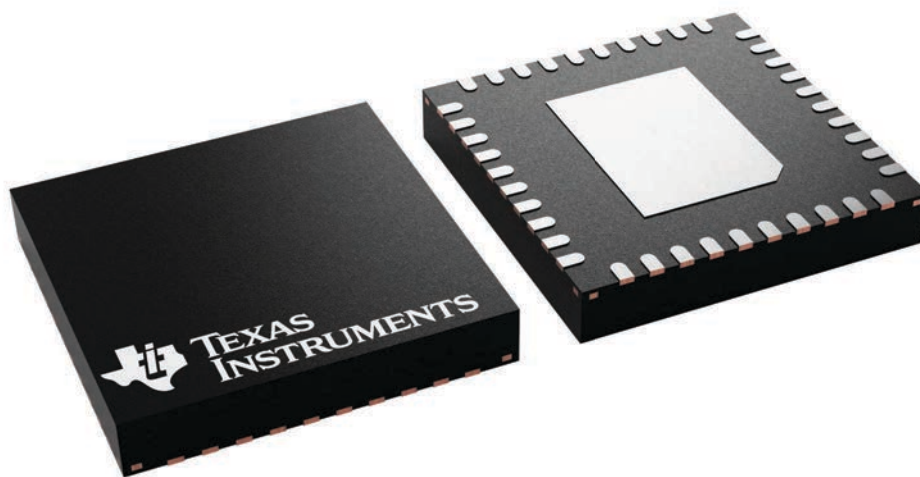

4225870/A

RHA0040H

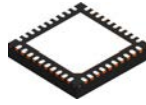

PACKAGE OUTLINE

VQFN - 1 mm max height

PLASTIC QUAD FLATPACK - NO LEAD

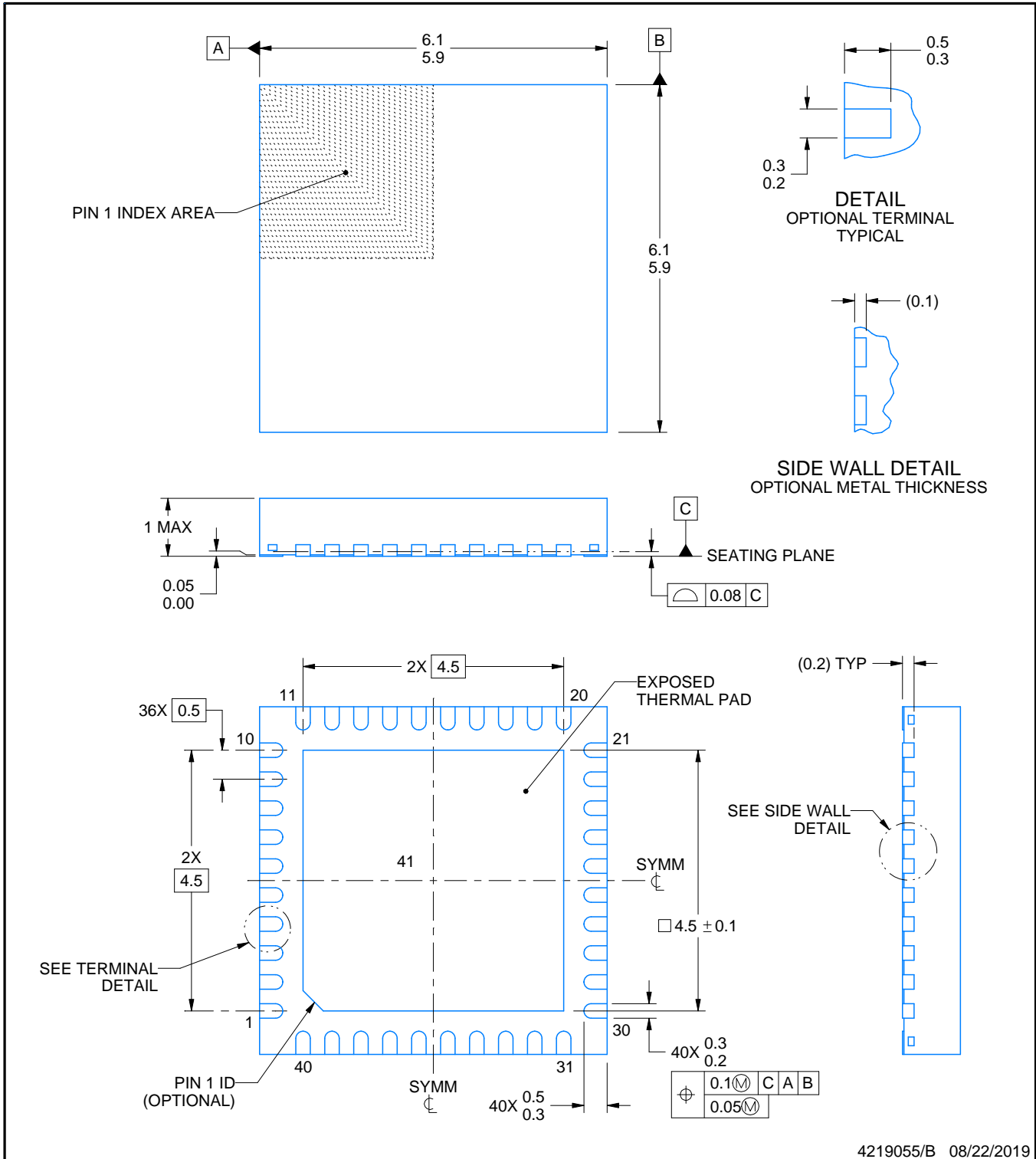

NOTES:

1. All linear dimensions are in millimeters. Any dimensions in parenthesis are for reference only. Dimensioning and tolerancing per ASME Y14.5M.
2. This drawing is subject to change without notice.
3. The package thermal pad must be soldered to the printed circuit board for thermal and mechanical performance.

IMPORTANT NOTICE AND DISCLAIMER

TI PROVIDES TECHNICAL AND RELIABILITY DATA (INCLUDING DATA SHEETS), DESIGN RESOURCES (INCLUDING REFERENCE DESIGNS), APPLICATION OR OTHER DESIGN ADVICE, WEB TOOLS, SAFETY INFORMATION, AND OTHER RESOURCES "AS IS" AND WITH ALL FAULTS, AND DISCLAIMS ALL WARRANTIES, EXPRESS AND IMPLIED, INCLUDING WITHOUT LIMITATION ANY IMPLIED WARRANTIES OF MERCHANTABILITY, FITNESS FOR A PARTICULAR PURPOSE OR NON-INFRINGEMENT OF THIRD PARTY INTELLECTUAL PROPERTY RIGHTS.

These resources are intended for skilled developers designing with TI products. You are solely responsible for (1) selecting the appropriate TI products for your application, (2) designing, validating and testing your application, and (3) ensuring your application meets applicable standards, and any other safety, security, regulatory or other requirements.

These resources are subject to change without notice. TI grants you permission to use these resources only for development of an application that uses the TI products described in the resource. Other reproduction and display of these resources is prohibited. No license is granted to any other TI intellectual property right or to any third party intellectual property right. TI disclaims responsibility for, and you will fully indemnify TI and its representatives against, any claims, damages, costs, losses, and liabilities arising out of your use of these resources.

TI's products are provided subject to [TI's Terms of Sale](#) or other applicable terms available either on [ti.com](https://www.ti.com) or provided in conjunction with such TI products. TI's provision of these resources does not expand or otherwise alter TI's applicable warranties or warranty disclaimers for TI products.

TI objects to and rejects any additional or different terms you may have proposed.

Mailing Address: Texas Instruments, Post Office Box 655303, Dallas, Texas 75265
Copyright © 2023, Texas Instruments Incorporated

Looking for pricing, stock, or lifecycle information?

Click below to explore more details on WIN SOURCE:

 [View ADS61JB23IRHAT](#) on WIN SOURCE

 [Texas Instruments](#) Information

Optimize Your Supply Chain with WIN SOURCE Solutions

-  Global Sourcing Solution
-  Obsolete Management
-  Cost Control Management
-  Shortage Management
-  Alternative Solution
-  Excess Inventory Management