



**THE DATASHEET OF
QT60160-ISG**



These devices are designed for low cost mobile and consumer electronics applications.

QMatrix™ technology employs transverse charge-transfer sensing electrode designs which can be made very compact and are easily wired. Charge is forced from an emitting electrode into the overlying panel dielectric, and then collected on a receiver electrode which directs the charge into a sampling capacitor which is then converted directly to digital form without the use of amplifiers.

Keys are configured in a matrix format that minimizes the number of required scan lines and device pins. The key electrodes can be designed into a conventional Printed Circuit Board (PCB) or Flexible Printed Circuit Board (FPCB) as a copper pattern, or as printed conductive ink on plastic film.

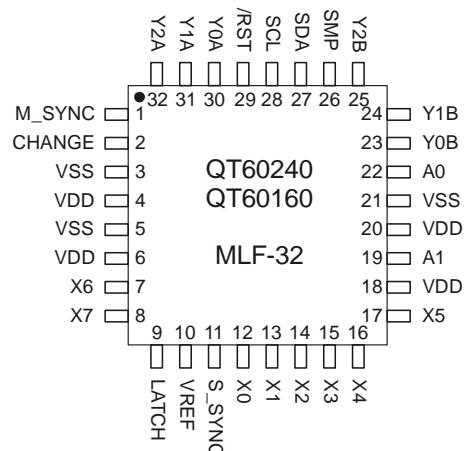

AT A GLANCE

- Number of keys:** 1 to 16 (QT60160), or 1 to 24 (QT60240)
- Technology:** Patented spread-spectrum charge-transfer (transverse mode)
- Key outline sizes:** 6mm x 6mm or larger (panel thickness dependent); widely different sizes and shapes possible
- Key spacings:** 8mm or wider, center to center (panel thickness dependent)
- Electrode design:** Two-part electrode shapes (drive-receive); wide variety of possible layouts
- Layers required:** One layer (with jumpers), two layers (no jumpers)
- Electrode materials:** PCB, FPCB, silver or carbon on film, ITO on film, Orgacon[†] ink on film
- Panel materials:** Plastic, glass, composites, painted surfaces (low particle density metallic paints possible)
- Adjacent Metal:** Compatible with grounded metal immediately next to keys
- Panel thickness:** Up to 50mm glass, 20mm plastic (key size dependent)
- Key sensitivity:** Individually settable via simple commands over serial interface
- Interface:** I²C slave mode (100kHz), or parallel output via external shift registers
- Moisture tolerance:** Best in class.
- Power:** 1.8V ~ 5.5V, 40µA (16 keys at 1.8V, 2s Low Power mode). Guaranteed to 1.62V.
- Package:** 32-pin 5 x 5mm MLF RoHS compliant
- Signal processing:** Self-calibration, auto drift compensation, noise filtering, Adjacent Key Suppression™
- Applications:** Mobile phones, remote controls, domestic appliances, PC peripherals, automotive

[†]Orgacon is a registered trademark of Agfa-Gevaert N.V

AVAILABLE OPTIONS

Part Number	Keys	T _A
QT60160-ISG	16	-40°C to +85°C
QT60240-ISG	24	-40°C to +85°C

Contents

1 Overview	3	5 I2C Operation	15
1.1 Introduction	3	5.1 Interface Bus	15
1.2 Part Differences	3	5.2 Transferring Data Bits	15
1.3 Enabling / Disabling Keys	3	5.3 START and STOP Conditions	15
2 Hardware and Functional	3	5.4 Address Packet Format	15
2.1 Matrix Scan Sequence	3	5.5 Data Packet Format	15
2.2 Burst Paring	3	5.6 Combining Address and Data Packets Into a Transmission	16
2.3 Cs Sample Capacitor Operation	3	6 Setups	17
2.4 Sample Capacitor Saturation	4	6.1 Introduction	17
2.5 Sample Resistors	4	6.2 Negative Threshold - NTHR	17
2.6 Signal Levels	4	6.3 Positive Threshold - PTHR	17
2.7 Matrix Series Resistors	5	6.4 Drift Compensation - NDRIFT, PDRIFT	17
2.8 Key Design	6	6.5 Detect Integrators - NDIL, FDIL	18
2.9 PCB Layout, Construction	6	6.6 Negative Recal Delay - NRD	18
2.9.1 Overview	6	6.7 Positive Recalibration Delay - PRD	18
2.9.2 LED Traces and Other Switching Signals	6	6.8 Burst Length - BL	19
2.9.3 PCB Cleanliness	6	6.9 Adjacent Key Suppression - AKS	19
2.10 Power Supply Considerations	6	6.10 Oscilloscope Sync - SSYNC	19
2.11 Startup / Calibration Times	7	6.11 Mains Sync - MSYNC	19
2.12 Reset Input	7	6.12 Sleep Duration - SLEEP	20
2.13 Spread Spectrum Acquisitions	7	6.13 Wake on Key Touch - WAKE	20
2.14 Detection Integrators	7	6.14 Awake Timeout - AWAKE	20
2.15 Sleep	7	6.15 Drift Hold Time - DHT	20
2.16 Wiring	8	6.16 Setups Block	21
3 Interfaces	10	7 Specifications	23
3.1 Introduction	10	7.1 Absolute Maximum Electrical Specifications	23
3.2 Shift Register Output Mode	10	7.2 Recommended Operating Conditions	23
3.3 I2C Port	10	7.3 DC Specifications	23
3.4 CHANGE Pin	11	7.4 Timing Specifications	23
4 Control Commands	12	7.5 Power Consumption	24
4.1 Introduction	12	7.6 Mechanical Dimensions	25
4.2 Writing Data to the Device	12	7.7 Marking	25
4.3 Reading Data From the Device	12	7.8 Moisture Sensitivity Level (MSL)	25
4.4 Report Detections for All Keys	12		
4.5 Raw Data Commands	13		
4.6 Cal All	13		
4.7 Setups	13		

1 Overview

1.1 Introduction

QT60xx0 devices are digital burst mode charge-transfer (QT) sensors designed specifically for matrix layout touch controls; they include all signal processing functions necessary to provide stable sensing under a wide variety of changing conditions. Only a few external parts are required for operation. The entire circuit can be built within a few square centimeters of single-sided PCB area. CEM-1 and FR1 punched, single-sided materials can be used for the lowest possible cost. The PCB's rear can be mounted flush on the back of a glass or plastic panel using a conventional adhesive, such as 3M VHB two-sided adhesive acrylic film.

Figure 1.1 Field Flow Between X and Y Elements

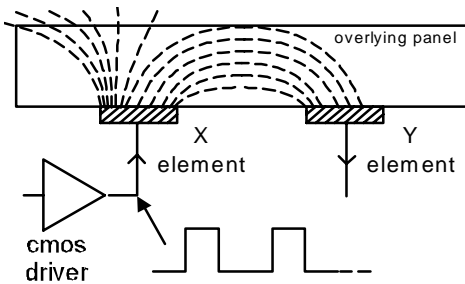

QT60xx0 devices employ transverse charge-transfer ('QT') sensing, a technology that senses changes in electrical charge forced across two electrode elements by a pulse edge (Figure 1.1). QT60xx0 devices allow a wide range of key sizes and shapes to be mixed together in a single touch panel.

The devices use an I²C interface to allow key data to be extracted and to permit individual key parameter setup. The command structure is designed to minimize the amount of data traffic while maximizing the amount of information conveyed.

In addition to normal operating and setup functions the device can also report back actual signal strengths .

QmBtn™ software for the PC can be used to program the operation of the IC, as well as read back key status and signal levels in real time.

1.2 Part Differences

There are two versions of the device; one is capable of a maximum of 16 keys (QT60160), the other is capable of a maximum of 24 keys (QT60240).

These devices are identical in all respects, except for the maximum number of keys specified. The keys can be located anywhere within an electrical grid of 8 X and 3 Y scan lines.

Unused keys are always pared from the burst sequence in order to optimize speed. Similarly, in a given part a lesser number of enabled keys will cause any unused acquisition burst timeslots to be pared from the sampling sequence to optimize acquire speed. Thus, if only 14 keys are actually enabled, only 14 timeslots are used for scanning.

1.3 Enabling / Disabling Keys

The NDIL parameter is used to enable and disable keys in the matrix. Setting NDIL = 0 for a key disables it (Section 6.5). At no time can the number of enabled keys exceed the maximum specified for the device (see Section 1.2).

On the QT60160, only the first 2 Y lines (Y0, Y1) are operational by default. On the QT60160, to use keys located on line Y2, one or more of the pre-enabled keys must be disabled simultaneously while enabling the desired new keys. This can be done in one Setups block load operation.

2 Hardware and Functional

2.1 Matrix Scan Sequence

The circuit operates by scanning each key sequentially, key by key. Key scanning begins with location X=0 / Y=0 (key 0). X axis keys are known as *rows* while Y axis keys are referred to as *columns* although this has no reflection on actual wiring. Keys are scanned sequentially by row, for example the sequence X0Y0 X1Y0 X7Y0, X0Y1, X1Y1... etc. Keys are also numbered from 0...23. Key 0 is located at X0Y0. Table 2.1 shows the key numbering.

Table 2.1 Key Numbers

	X7	X6	X5	X4	X3	X2	X1	X0	
Y0	7	6	5	4	3	2	1	0	Key numbers
Y1	15	14	13	12	11	10	9	8	
Y2	23	22	21	20	19	18	17	16	

Each key is sampled in a burst of acquisition pulses whose length is determined by the Setups parameter BL (page 19); this can be set on a per-key basis. A burst is completed entirely before the next key is sampled; at the end of each burst the resulting signal is converted to digital form and processed. The burst length directly impacts key gain; each key can have a unique burst length in order to allow tailoring of key sensitivity on a key-by-key basis.

2.2 Burst Paring

Keys that are disabled by setting NDIL = 0 (Section 6.5, page 18) have their bursts removed from the scan sequence to save scan time. As a consequence, the fewer keys that are used the faster the device can respond. All calibration times are reduced when keys are disabled.

2.3 Cs Sample Capacitor Operation

Cs capacitors absorb charge from the key electrodes on the rising edge of each X pulse. On each falling edge of X, the Y matrix line is clamped to ground to allow the electrode and wiring charges to neutralize in preparation for the next pulse. With each X pulse charge accumulates on Cs causing a staircase increase in its differential voltage.

After the burst completes, the device clamps the Y line to ground causing the opposite terminal to go negative. The charge on Cs is then measured using an external resistor to ramp the negative terminal upwards until a zero crossing is achieved. The time required to zero cross becomes the measurement result.

The Cs should be connected as shown in Figure 2.7, page 9. The value of these capacitors is not critical but 4.7nF is recommended for most cases. They should be 10 percent X7R ceramics. If the transverse capacitive coupling from X to Y is large enough the voltage on a Cs capacitor can saturate, destroying gain. In such cases the burst length should be reduced and/or the Cs value increased. See Section 2.4.

If a Y line is not used its corresponding Cs capacitor may be omitted and the pins left floating.

2.4 Sample Capacitor Saturation

Cs voltage saturation at a pin YnB is shown in Figure 2.1 Saturation begins to occur when the voltage at a YnB pin becomes more negative than -0.25V at the end of the burst. This nonlinearity is caused by excessive voltage accumulation on Cs inducing conduction in the pin protection diodes. This badly saturated signal destroys key gain and introduces a strong thermal coefficient which can cause 'phantom' detection. The cause of this is either from the burst length being too long, the Cs value being too small, or the X-Y transfer coupling being too large. Solutions include loosening up the key structure interleaving, more separation of the X and Y lines on the PCB, increasing Cs, and decreasing the burst length.

Increasing Cs will make the part slower; decreasing burst length will make it less sensitive. A better PCB layout and a looser key structure (up to a point) have no negative effects.

Cs voltages should be observed on an oscilloscope with the matrix layer bonded to the panel material; if the Rs side of any Cs ramps more negative than -0.25 volts during any burst (not counting overshoot spikes which are probe artifacts), there is a potential saturation problem.

Figure 2.2 shows a defective waveform similar to that of 2.1, but in this case the distortion is caused by excessive stray capacitance coupling from the Y line to AC ground; for example, from running too near and too far alongside a ground trace, ground plane, or other traces. The excess coupling causes the charge-transfer effect to dissipate a significant portion of the received charge from a key into the stray capacitance. This phenomenon is more subtle; it can be best detected by increasing BL to a high count and watching what the waveform does as it descends towards and below -0.25V. The waveform will appear deceptively straight, but it will slowly start to flatten even before the -0.25V level is reached.

A correct waveform is shown in Figure 2.3. Note that the bottom edge of the bottom trace is substantially straight (ignoring the downward spikes).

Unlike other QT circuits, the Cs capacitor values on QT60xx0 devices have no effect on conversion gain. However, they do affect conversion time.

Unused Y lines should be left open.

2.5 Sample Resistors

There are three sample resistors (Rs) used to perform single-slope ADC conversion of the acquired charge on each Cs capacitor. These resistors directly control acquisition gain; larger values of Rs will proportionately increase signal gain. For most applications Rs should be 1MΩ. Unused Y lines do not require an Rs resistor.

Figure 2.1 VCs - Nonlinear During Burst
(Burst too long, or Cs too small, or X-Y transcapacitance too large)

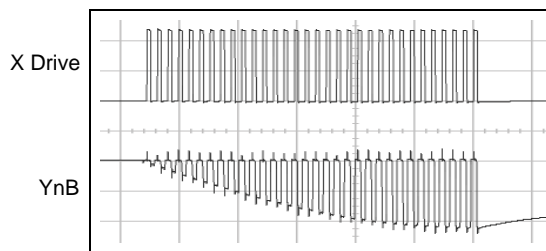

Figure 2.2 VCs - Poor Gain, Nonlinear During Burst
(Excess capacitance from Y line to Gnd)

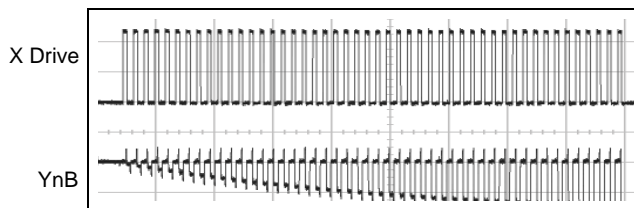

Figure 2.3 VCs - Correct

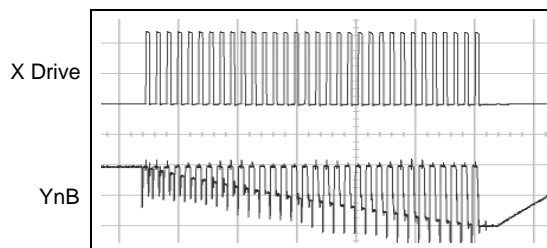
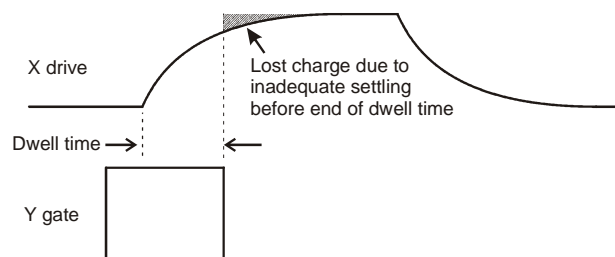

Figure 2.4 X-Drive Pulse Roll-off and Dwell Time

The Dwell time is fixed at ~500ns - see Section 2.7



2.6 Signal Levels

Quantum's QmBtn software makes it is easy to observe the absolute level of signal received by the sensor on each key. The signal values should normally be in the range of 200 to 750 counts with properly designed key shapes and values of Rs. However, long adjacent runs of X and Y lines can also artificially boost the signal values, and induce signal saturation; this is to be avoided. The X-to-Y coupling should come mostly from intra-key electrode coupling, not from stray X-to-Y trace coupling.

Figure 2.5 Probing X-Drive Waveforms With a Coin

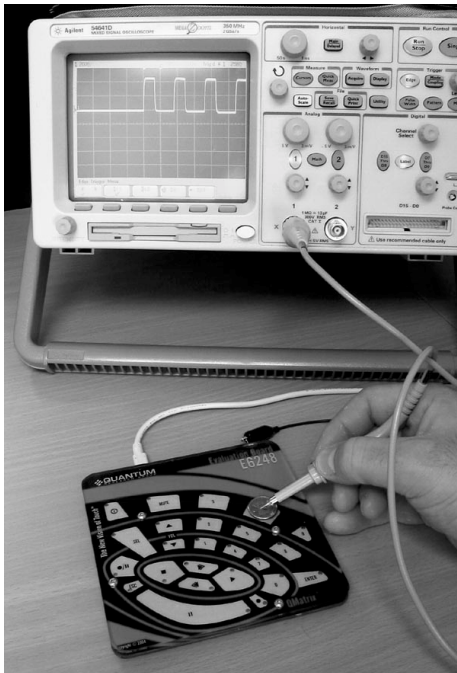

QmBtn software is available free of charge on Quantum's website www.qprox.com.

The signal swing from the smallest finger touch should preferably exceed 8 counts, with 12 being a reasonable target. The signal threshold setting (NTHR) should be set to a value guaranteed to be less than the signal swing caused by the smallest touch.

Increasing the burst length (BL) parameter will increase the signal strengths as will increasing the sampling resistor (R_s) values.

2.7 Matrix Series Resistors

The X and Y matrix scan lines can use series resistors (referred to as R_x and R_y respectively) for improved EMC performance (Figure 2.7, page 9).

X drive lines require R_x in most cases to reduce edge rates and thus reduce RF emissions. Typical values range from $1K\Omega$ to $20K\Omega$.

Y lines need R_y to reduce EMC susceptibility problems and in some extreme cases, ESD. Typical Y values are about $1K\Omega$. Y resistors act to reduce noise susceptibility problems by forming a natural low-pass filter with the C_s capacitors.

It is essential that the R_x and R_y resistors and C_s capacitors be placed very close to the chip. Placing these parts more than a few millimeters away opens the circuit up to high frequency interference problems (above 20MHz) as the trace lengths between the components and the chip start to act as RF antennae.

Figure 2.6 Recommended Key Structure

'T' should ideally be similar to the complete thickness the fields need to penetrate to the touch surface. Smaller dimensions will also work but will give less signal strength. If in doubt, make the pattern coarser. The lower figure shows a simpler structure used for compact key layouts, for example for mobile phones. A layout with a common X drive and three receive electrodes is depicted.

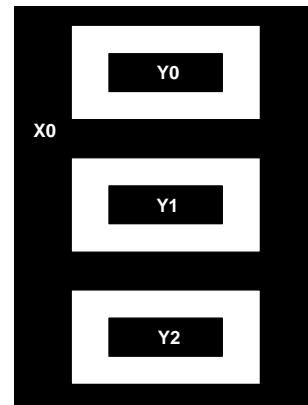
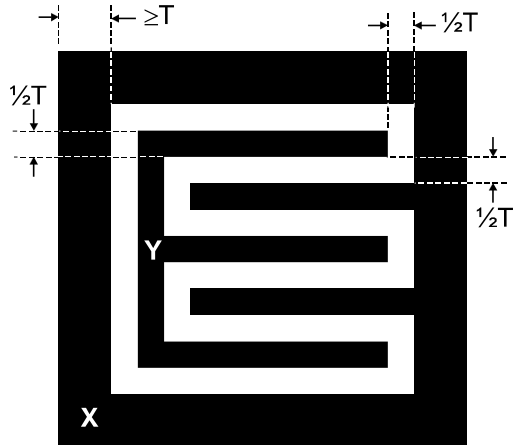

The upper limits of R_x and R_y are reached when the signal level and hence key sensitivity are clearly reduced. The limits of R_x and R_y will depend on key geometry and stray capacitance, and thus an oscilloscope is required to determine optimum values of both.

Dwell time is the duration in which charge coupled from X to Y is captured (Figure 2.4, page 4). Increasing R_x values will cause the leading edge of the X pulses to increasingly roll off, causing the loss of captured charge (and hence loss of signal strength) from the keys.

The dwell time of these parts is fixed at 500ns. If the X pulses have not settled within 500ns, key gain will be reduced; if this happens, either the stray capacitance on the X line(s) should be reduced (by a layout change, for example by reducing X line exposure to nearby ground planes or traces), or, the R_x resistor needs to be reduced in value (or a combination of both approaches).

One way to determine X line settling time is to monitor the fields using a patch of metal foil or a small coin over the key (Figure 2.5). Only one key along a particular X line needs to be observed, as each of the keys along that X line will be identical. The 500ns dwell time should exceed the observed 95 percent settling of the X-pulse by 25 percent or more.

In almost all cases, Ry should be set equal to Rx, which will ensure that the charge on the Y line is fully captured into the Cs capacitor.

2.8 Key Design

Circuits can be constructed out of a variety of materials including conventional FR-4, Flexible Printed Circuit Boards (FPCB), silver silk-screened on PET plastic film, and even inexpensive punched single-sided CEM-1 and FR-2.

The actual internal pattern style is not as important as the need to achieve regular X and Y widths and spacings of sufficient size to cover the desired graphical key area or a little bit more; ~3mm oversize is acceptable in most cases, since the key's electric fields drop off near the edges anyway. The overall key size can range from 6mm x 6mm up to 100mm x 100mm but these are not hard limits. The keys can be any shape including round, rectangular, square, etc. The internal pattern can be interdigitated as shown in Figure 2.6.

For small, dense keypads, electrodes such as shown in the lower half of Figure 2.6 can be used. Where the panels are thin (usually mobile phones have panels under 2mm thick) the electrode density can be quite high.

For better surface moisture suppression, the outer perimeter of X should be as wide as possible, and there should be no ground planes near the keys. The variable 'T' in this drawing represents the total thickness of all materials that the keys must penetrate.

2.9 PCB Layout, Construction

2.9.1 Overview

It is best to place the chip near the touch keys on the same PCB so as to reduce X and Y trace lengths, thereby reducing the chances for EMC problems. Long connection traces act as RF antennae. The Y (receive) lines are much more susceptible to noise pickup than the X (drive) lines.

Even more importantly, all signal related discrete parts (resistors and capacitors) should be very close to the body of the chip. Wiring between the chip and the various resistors and capacitors should be as short and direct as possible to suppress noise pickup.



Ground planes and traces should NOT be used around the keys and the Y lines from the keys. Ground areas, traces, and other adjacent signal conductors that act as AC ground (such as Vdd and LED drive lines etc.) will absorb the received key signals and reduce signal-to-noise ratio (SNR) and thus will be counterproductive. Ground planes around keys will also make water film effects worse.

Ground planes, if used, should be placed under or around the QT chip itself and the associated resistors and capacitors in the circuit, under or around the power supply, and back to a connector, but nowhere else.

2.9.2 LED Traces and Other Switching Signals

Digital switching signals near the Y lines will induce transients into the acquired signals, deteriorating the SNR performance of the device. Such signals should be routed away from the Y lines, or the design should be such that these lines are not switched during the course of signal acquisition (bursts).

LED terminals which are multiplexed or switched into a floating state and which are within or physically very near a key structure (even if on another nearby PCB) should be bypassed to either Vss or Vdd with at least a 10nF capacitor to suppress capacitive coupling effects which can induce false signal shifts. The bypass capacitor does not need to be next to the LED, in fact it can be quite distant. The bypass capacitor is noncritical and can be of any type.

LED terminals which are constantly connected to Vss or Vdd do not need further bypassing.

2.9.3 PCB Cleanliness

All capacitive sensors should be treated as highly sensitive circuits which can be influenced by stray conductive leakage paths. QT devices have a basic resolution in the femtofarad range; in this region, there is no such thing as 'no clean flux'. Flux absorbs moisture and becomes conductive between solder joints, causing signal drift and resultant false detections or transient losses of sensitivity or instability. Conformal coatings will trap in existing amounts of moisture which will then become highly temperature sensitive.

The designer should specify ultrasonic cleaning as part of the manufacturing process, and in cases where a high level of humidity is anticipated, the use of conformal coatings after cleaning to keep out moisture.

2.10 Power Supply Considerations

The power supply can range from +1.8V to +5V nominal. The device can tolerate $\pm 5\text{mV/s}$ short-term power supply fluctuations. If the power supply fluctuates slowly with temperature, the device will track and compensate for these changes automatically with only minor changes in sensitivity. If the supply voltage drifts or shifts quickly, the drift compensation mechanism will not be able to keep up, causing sensitivity anomalies or false detections.

As these devices use the power supply itself as an analog reference, the power should be very clean and come from a separate regulator. A standard inexpensive Low Dropout (LDO) type regulator should be used that is not also used to power other loads such as LEDs, relays, or other high current devices. Load shifts on the output of the LDO can cause Vdd to fluctuate enough to cause false detection or sensitivity shifts.

Caution: A regulator IC shared with other logic can result in erratic operation and is **not** advised.

A regulator can be shared among two or more QT devices on one board. One such regulator known to work well with QT chips is the S-817 series from Seiko Instruments (Seiko Instruments - www.sii-ic.com).

A single ceramic 0.1uF bypass capacitor, with short traces, should be placed very close to supply pins 3, 4, 5 and 6 of the IC. Failure to do so can result in device oscillation, high current consumption, erratic operation etc. Pins 18, 20, and 21 do not require bypassing.

2.11 Startup / Calibration Times

The devices require initialization times of up to 20ms. A calibration takes one matrix scan.

Disabled keys are subtracted from the burst sequence and thus the cal time is shortened. The scan time should be measured on an oscilloscope.

2.12 Reset Input

The /RST pin can be used to reset the device to simulate a power-down cycle, in order to bring the device up into a known state should communications with the device be lost. The pin is active low, and a low pulse lasting at least 10µs must be applied to this pin to cause a reset.

The reset pin has an internal 30KΩ - 60KΩ resistor. A 2.2µF capacitor plus a diode to Vdd can be connected to this pin as a traditional reset circuit, but this is not required.

If an external hardware reset is not used, the reset pin may be connected to Vdd or left floating.

2.13 Spread Spectrum Acquisitions

QT60xx0 devices use spread-spectrum burst modulation. This has the effect of drastically reducing the possibility of EMI effects on the sensor keys, while simultaneously spreading RF emissions. This feature is hard-wired into the device and cannot be disabled or modified.

Spread spectrum is configured as a frequency chirp over a wide range of frequencies for robust operation.

2.14 Detection Integrators

See also Section 6.5, page 18.

The devices feature a detection integration mechanism, which acts to confirm a detection in a robust fashion. A per-key counter is incremented each time the key has exceeded its threshold and stayed there for a number of acquisitions. When this counter reaches a preset limit the key is finally declared to be touched.

For example, if the limit value is 10, then the device has to exceed its threshold and stay there for 10 acquisitions in succession without going below the threshold level, before the key is declared to be touched. If on any acquisition the signal is not seen to exceed the threshold level, the counter is cleared and the process has to start from the beginning.

The QT60xx0 uses a two-tier confirmation mechanism having two such counters for each key. These can be thought of as 'inner loop' and 'outer loop' confirmation counters.

The 'inner' counter is referred to as the 'fast-DI'; this acts to attempt to confirm a detection via rapid successive acquisition bursts, at the expense of delaying the sampling of the next key. Each key has its own fast-DI counter and limit value; these limits can be changed via the Setups block on a per-key basis.

The 'outer' counter is referred to as the 'normal-DI'; this DI counter increments whenever the fast-DI counter has reached its limit value. If a fast-DI counter failed to reach its terminal count, the corresponding normal-DI counter is also reset. The normal-DI counter also has a limit value which is settable on a per-key basis. If a normal-DI counter reaches its terminal count, the corresponding key is declared to be touched and becomes 'active'. Note that the normal-DI can only be incremented once per complete keyscan cycle, i.e. more slowly, whereas the fast-DI is incremented 'on the spot' without interruption.

The net effect of this mechanism is a multiplication of the inner and outer counters and hence a highly noise-resistance sensing method. If the inner limit is set to 5, and the outer to 3, the net effect is $5 \times 3 = 15$ successive threshold crossings to declare a key as active.

2.15 Sleep

The device will sleep whenever possible to conserve power. Periodically, the part will wake automatically, scan the matrix, and return to sleep unless there is activity which demands further attention. The part will always return to sleep automatically once all activity has ceased. The time for which the part will sleep before automatically awakening can be configured.

A new communication with the device while it is asleep will cause it to wake up, service the communication and scan the matrix. At least one full matrix scan is always performed after waking up and before returning to sleep.

At the end of each matrix scan, the part will return to sleep unless recent activity demands further attention. If there has been recent activity, the part will perform another complete matrix scan and then attempt to sleep once again. This process is repeated indefinitely until the activity stops and the part returns to sleep.

Key touch activity will prevent the part from sleeping. The part will not sleep if any touch events were detected at any key in the most recent scan of the key matrix.

2.16 Wiring

Table 2.2 Pin Listing

Pin	Function	I/O	Comments	If Unused, Connect To...
1	M_SYNC	I	Mains Sync input	Vdd
2	CHANGE	O	State change notification	Leave open
3	Vss	P	Supply ground	-
4	Vdd	P	Power, +1.8V to +5V	-
5	Vss	P	Supply ground	-
6	Vdd	P	Power, +1.8V to +5V	-
7	X6	O	X matrix drive line	Leave open
8	X7	O	X matrix drive line	Leave open
9	LATCH	O	Shift Register Latch Output	Leave open
10	Vref	I	Ground	-
11	S_SYNC	O	Oscilloscope sync	Leave open
12	X0	O	X matrix drive line	Leave open
13	X1	O	X matrix drive line	Leave open
14	X2	O	X matrix drive line	Leave open
15	X3	O	X matrix drive line	Leave open
16	X4	O	X matrix drive line	Leave open
17	X5	O	X matrix drive line	Leave open
18	Vdd	P	Power, +1.8V to +5V	-
19	A1	I	Com port address 1	-
20	Vdd	P	Power, +1.8V to +5V	-
21	Vss	P	Supply ground	-
22	A0	I	Com port address 0	-
23	Y0B	I	Y line connection	Leave open
24	Y1B	I	Y line connection	Leave open
25	Y2B	I	Y line connection	Leave open
26	SMP	O	Sample output.	-
27	SDA	I/O	Serial Interface Data	-
28	SCL	I/O	Serial Interface Clock	-
29	/RST	I	Reset low; has internal 30K - 60K pull-up	Leave open or Vdd
30	Y0A	I	Y line connection	Leave open
31	Y1A	I	Y line connection	Leave open
32	Y2A	I	Y line connection	Leave open

I Input only
 O Output only, push-pull
 OD Open drain output
 I/O Input and output
 P Ground or power

Figure 2.7 Wiring Diagram

See Table 2.2 for further connection information.

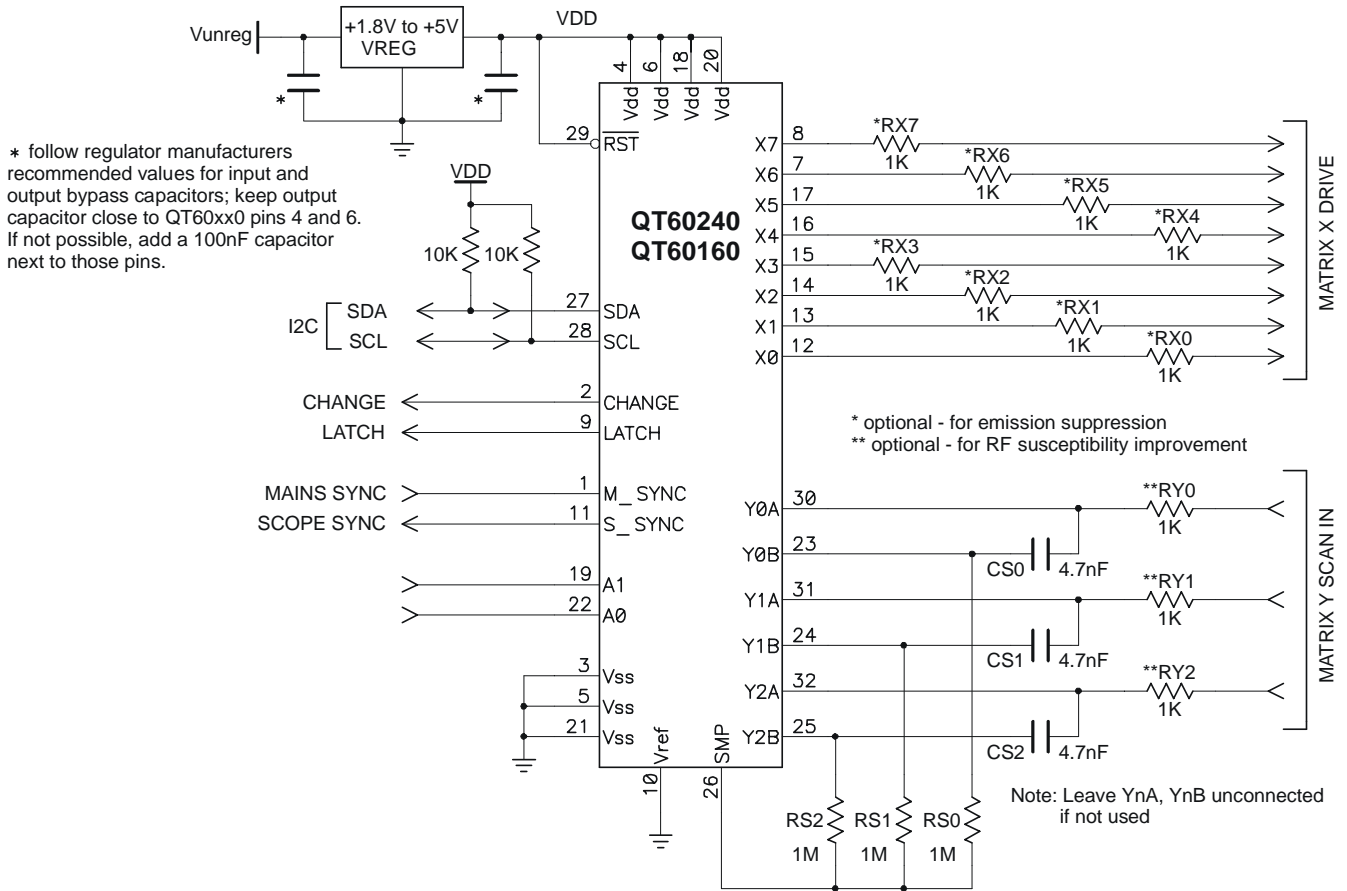

Suggested regulator manufacturers:

- Toko (XC6215 series)
- Seiko (S817 series)
- BCDSemi (AP2121 series)

3 Interfaces

3.1 Introduction

The QT60xx0 can be configured to communicate either over an I²C bus or a shift register type Serial Peripheral Interface (SPI).

The pins A0, A1 are used to configure the type of interface and the I²C address if this mode is used. The modes and I²C addresses are available as shown in Table 3.1 below.

Table 3.1 Interface Details

A1	A0	Interface
Vss	Vss	Shift Register
Vss	Vdd	I ² C Address 7
Vdd	Vss	I ² C Address 17
Vdd	Vdd	I ² C Address 117

3.2 Shift Register Output Mode

When the option jumpers are both set at Vss, the device disables the I²C interface and instead generates output suitable for driving a shift register.

The shift register data is output at pin 27 (SDA). The clock is output at pin 28 (SCL). The data is clocked on the positive-going transition of SCL. Data is transferred from the shift registers to the latched outputs on the positive-going transition of LATCH. An example shift register connection is shown in Figure 3.1.

The shift register data is output over the duration of a matrix scan, as each key is being processed, and it is latched at the end of the scan. The overall communication time depends on the matrix scan time.

Table 3.2 Shift Register

Parameter	Legend	Units
SCL low pulse width	tSCL	500ns min
SCL high pulse width	tSCH	125us min
LATCH pulse width	tLATCH	500ns min
SDA data to SCL clock hold time	tSDA-SCL	75us min

Figure 3.2, page 11 shows a full shift register cycle with keys 3, 10 and 15 activated. Key Scan represents the time when the chip is measuring signal from each key. SCL, SDA and LATCH represent their respective signals from the chip. SCL is an active low clock output. SDA is the data output; high if the key is in detect and low if it is not. LATCH pulses low when the data transfer is complete.

Data output proceeds as soon as the key has been processed. Most keys do not get processed during the key scan. If so, these keys are processed and the data is output after the complete key scan.

The internal settings of the device in Shift Register mode are the default factory settings found in Table 6.2. This means the device will operate with a Burst Length of 48 on all keys, and a Sleep time of 125ms for example. These settings cannot be changed in this mode.

In Shift Register mode, the CHANGE pin is inactive and should be left open.

3.3 I²C Port

These devices use I²C communications, in slave mode only.

The QT60160/QT60240 will only respond to the correct address match. I²C operating parameters are as follows:

Max Data Transfer: 100KHz
Address: 7-bit

The match address is selected via pins A0 and A1. Table 3.1 shows the address selections.

The QT60160/QT60240 allows multiple byte transmissions to provide a more efficient communication. This is particularly useful to retrieve several information bytes at once. Every time the host retrieves data from the QT60160/QT60240, an internal address pointer is incremented.

Therefore, the host only needs to write the initial address pointer of interest (the lowest address), followed by read cycles for as many bytes as required.

Figure 3.1 Shift Register Output

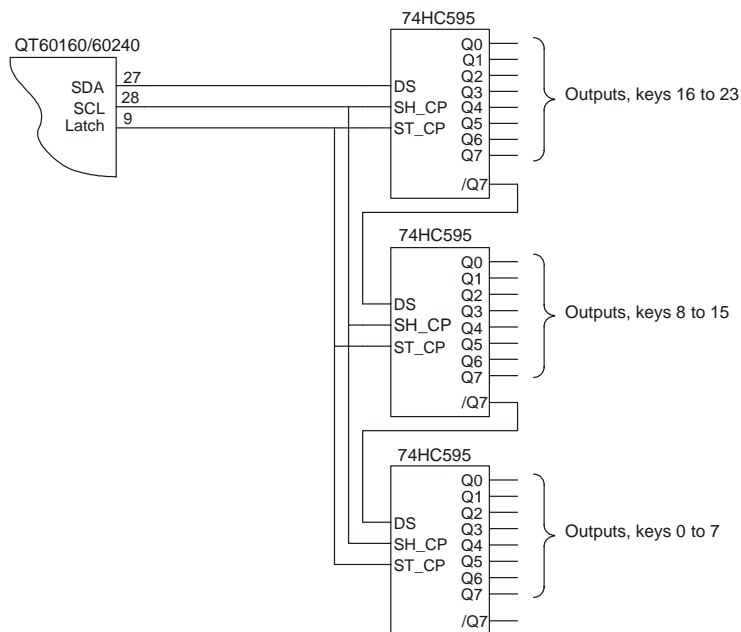

3.4 CHANGE Pin

Pin 2 (CHANGE) is an active-high output that can be used to alert the host to key touches or key releases, thus reducing the need for wasteful I²C communications. Normally, the host can simply not bother to communicate with the device, except when the CHANGE pin goes high.

CHANGE becomes active only when there is a change in key state (either touch or touch release); CHANGE goes low again only when the host performs a read from address 1, the detect status register for all keys on Y0. CHANGE does not self-clear; only an I²C read from location 1 will cause it to clear.

It is important to read all three key state addresses to ensure the host has a complete picture of which keys have changed.

In Shift Register mode the CHANGE pin does not operate and should be left open.

Every key can be individually configured to wake a host microcontroller upon a touch change; so, a product can wake from sleep when any key state changes, or only when certain desired keys change state. The configuration is set in the Setups block (Section 6.13) on a key-by-key basis.

Figure 3.2 Shift Register Cycle

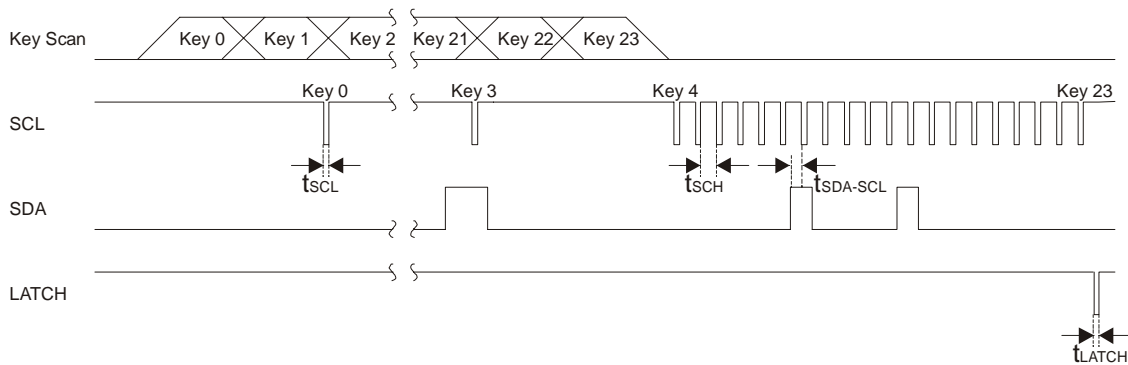

4 Control Commands

4.1 Introduction

The devices feature a set of commands which are used for control and status reporting.

As well as Table 4.1 refer to Table 6.1, page 21 for further details.

Table 4.1 Memory Map

Address	Use	Access
0	Reserved	Read
1	Detect status for keys 0 to 7, one bit per key	Read
2	Detect status for keys 8 to 15, one bit per key	Read
3	Detect status for keys 16 to 23, one bit per key	Read
4 to 123	Data for keys 0 to 23, in sequence. Refer to Table 4.3 for details	Read
125	Recalibrate all keys. Write 0x55 to this address location to recalibrate all the keys	Write
130	Setups write-unlock. Write 0x55 immediately before writing setups	Write
131 to 253	Setups - refer to Table 5.2 for details	Read/Write

Poll rate: The host can make use of the CHANGE pin output to initiate a communication; this will guarantee the optimal polling rate.

If the host cannot make use of the CHANGE pin the poll rate in normal 'run' operation should be no faster than once per matrix scan (see Section 7.4, page 23). Typically 10 to 20ms is more than fast enough to extract the key status. Anything faster will not provide new information and will slow down the chip operation.

Sending or reading the setup block is an exception, in this case the host can send the data at the maximum possible rate.

Run Poll Sequence: In normal run mode the host should limit traffic with a minimalist control structure. The host should just read the three detect status registers (see Figure 4.1, page 14).

Repeated Start: Using repeated start is not allowed and can cause communication failure.

4.2 Writing Data to the Device

The sequence of events required to write data to the device is shown next.

■ Host to Device □ Device to Host



Key	
S	Start condition
SLA+W	Slave address plus write bit
A	Acknowledge bit
MemAddress	Target memory address within device
Data	Data to be written
P	Stop condition

The host initiates the transfer by sending the START condition, and follows this by sending the slave address of the device together with the Write-bit. The device sends an ACK. The host then sends the memory address within the device it wishes to write to. The device sends an ACK. The host transmits one or more data bytes; each will be acknowledged by the device.

If the host sends more than one data byte, they will be written to consecutive memory addresses. The device automatically increments the target memory address after writing each data byte. After writing the last data byte, the host should send the STOP condition.

The host should not try to write beyond address 255 because the device will not increment the internal memory address beyond this.

4.3 Reading Data From the Device

The sequence of events required to read data from the device is shown next.

■ Host to Device □ Device to Host

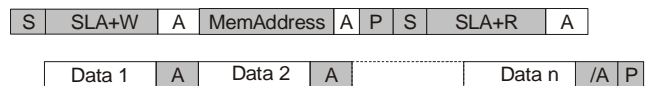

Key	
S	Start condition
SLA+W	Slave address plus write bit
A	Acknowledge bit
MemAddress	Target memory address within device
Data	Data from device
P	Stop condition
SLA+R	Slave address plus read bit
/A	Not Acknowledge bit/indicates last byte transmission

The host initiates the transfer by sending the START condition, and follows this by sending the slave address of the device together with the Write-bit. The device sends an ACK. The host then sends the memory address within the device it wishes to read from. The device sends an ACK.

The host must then send a STOP and a START condition followed by the slave address again but this time accompanied by the Read-bit. The device will return an ACK, followed by a data byte. The host must return either an ACK or NACK. If the host returns an ACK, the device will subsequently transmit the data byte from the next address. Each time a data byte is transmitted, the device automatically increments the internal address. The device will continue to return data bytes until the host responds with a NACK. The host should terminate the transfer by issuing the STOP condition.

4.4 Report Detections for All Keys

Address 1: detect status for keys 0 to 7

Address 2: detect status for keys 8 to 15

Address 3: detect status for keys 16 to 23

Each location indicates all keys in detection, if any, as a bitfield; touched keys report as 1's, untouched or disabled keys report as 0's.

Note: the change pin is cleared on reading address 1.

Table 4.2 Bits for Key Reporting and Numbering

Address	Bit Number							
	7	6	5	4	3	2	1	0
1	7	6	5	4	3	2	1	0
2	15	14	13	12	11	10	9	8
3	23	22	21	20	19	18	17	16

Note: the device should be reset after disabling keys because, if a key was in detect when it was disabled, it could incorrectly report detect.

4.5 Raw Data Commands

Addresses 4 to 123 allow data to be read for each key. There are a total of 24 keys and 5 bytes of data per key, yielding a total of 120 addresses. These addresses are read-only.

The data for the keys is mapped in sequence, starting with key 0 at addresses 4 to 8. The data for key 15 is located at addresses 79 to 83, and that for key 23 is located at addresses 119 to 123. Table 4.3 summarizes this.

Table 4.3 Key Data

Address	Key #	Use
4	0	Signal LSB
5	0	Signal MSB
6	0	Reference LSB
7	0	Reference MSB
8	0	DetectCount (lower nibble)
9	1	Signal LSB
10	1	Signal MSB
11	1	Reference LSB
12	1	Reference MSB
13	1	DetectCount (lower nibble)
14	2	Signal LSB
15	2	Signal MSB
16	2	Reference LSB
17	2	Reference MSB
18	2	DetectCount (lower nibble)
19 to 118	3 to 22	Range of values
119	23	Signal LSB
120	23	Signal MSB
121	23	Reference LSB
122	23	Reference MSB
123	23	DetectCount (lower nibble)

There are five bytes of data for each key. The first two are the key's 16-bit signal, and the second two are the key's 16-bit reference. These are followed by the Detect Integrator Count, which is a 4-bit value stored in the lower nibble. In the case of both the signal and reference, the 16-bit values are accessed as two 8-bit bytes, stored LSB first.

4.6 Cal All

A value of 0x55 must be written to address 125. Upon receiving this command the QT60xx0 will recalibrate all of the keys. Recalibration will start at the beginning of the next full matrix scan and last for one scan cycle.

4.7 Setups

The location "Setups write-unlock", address 130, allows write access to the setups. Normally the setups are write-protected; the write-protection is engaged as soon as a read operation is performed at any address. By writing a value of 0x55 to this address, the write-protection is disengaged. This address is located conveniently immediately before the setups so that the write protection may be disengaged and the setups written in a single I²C communication sequence. Reading this address is undefined.

Addresses 131 to 252 provide read/write access to the setups. Details of different setups can be found in Section 6, page 17.

When the host is writing a new setup block the values are being recorded into EEPROM as they arrive from the host.

Figure 4.1 Power-on or Hardware Reset Flow Chart

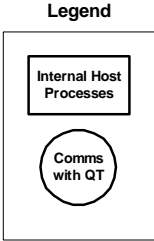
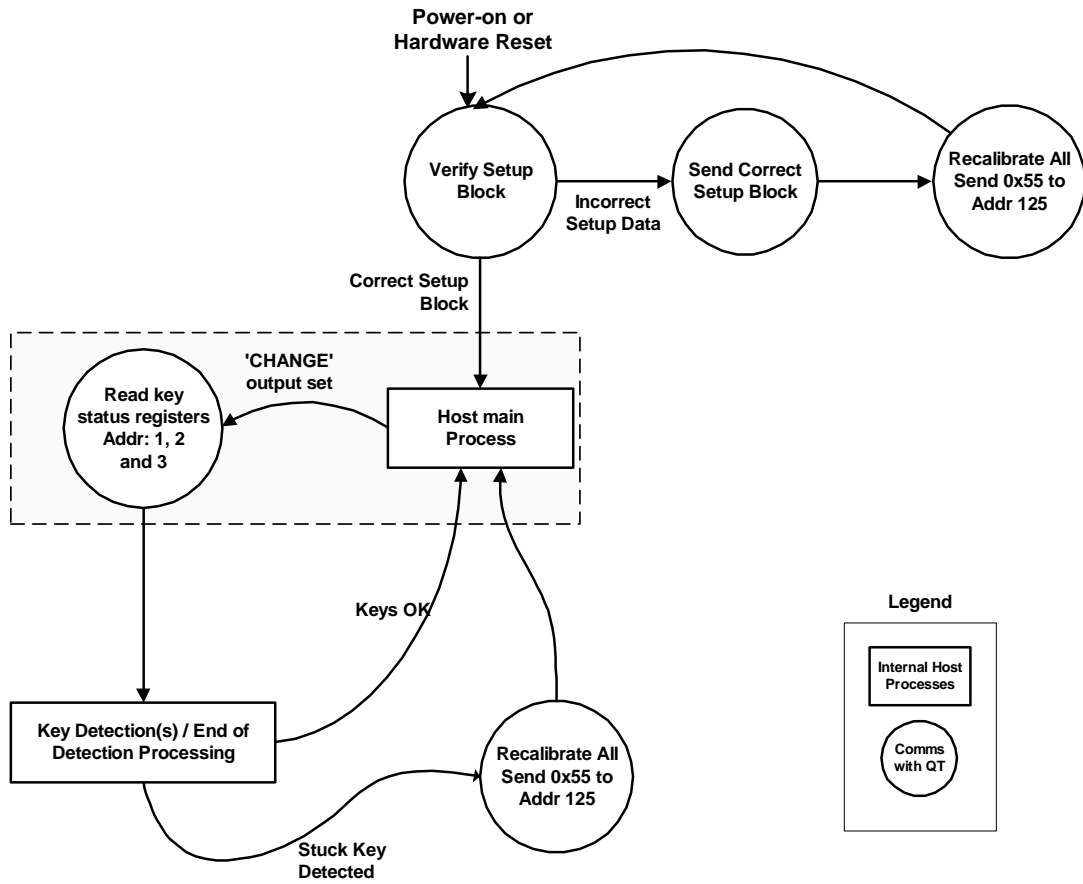

5 I²C Operation

5.1 Interface Bus

More detailed information about I²C is available from www.i2c-bus.org. Devices are connected onto the I²C bus as shown in Figure 5.1. Both bus lines are connected to V_{dd} via pull-up resistors. The bus drivers of all I²C devices must be open-drain type. This implements a wired-AND function which allows any and all devices to drive the bus, one at a time. A low level on the bus is generated when a device outputs a zero.

Figure 5.1 I²C Interface Bus

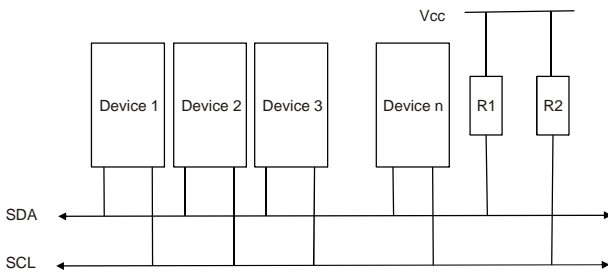

Table 5.1 I²C Bus Specifications

Parameter	Unit
Address space	7-bit
Maximum bus speed (SCL)	100 kHz
Hold time START condition	4μs minimum
Setup time for STOP condition	4μs minimum
Bus free time between a STOP and START condition	4.7μs minimum

5.2 Transferring Data Bits

Each data bit transferred on the bus is accompanied by a pulse on the clock line. The level of the data line must be stable when the clock line is high; The only exception to this rule is for generating START and STOP conditions.

Figure 5.2 Data Transfer

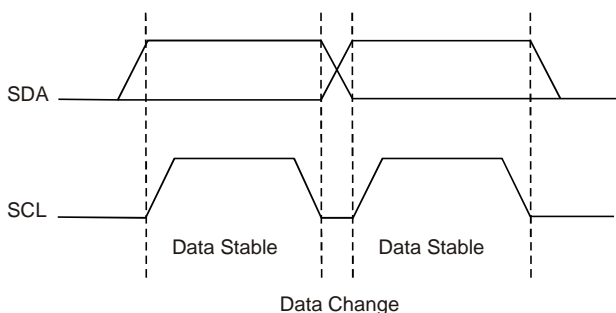

5.3 START and STOP Conditions

The host initiates and terminates a data transmission. The transmission is initiated when the host issues a START condition on the bus, and is terminated when the host issues a STOP condition. Between START and STOP conditions, the bus is considered busy. As shown below, START and STOP conditions are signaled by changing the level of the SDA line when the SCL line is high.

Figure 5.3 START and STOP Conditions

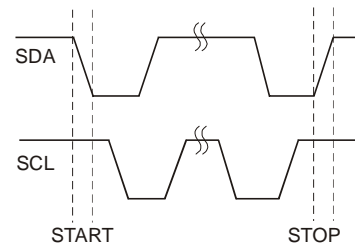

5.4 Address Packet Format

All address packets are 9 bits long, consisting of 7 address bits, one READ/WRITE control bit and an acknowledge bit. If the READ/WRITE bit is set, a read operation is performed, otherwise a write operation is performed. When the device recognizes that it is being addressed, it will acknowledge by pulling SDA low in the ninth SCL (ACK) cycle. An address packet consisting of a slave address and a READ or a WRITE bit is called SLA+R or SLA+W, respectively.

The most significant bit of the address byte is transmitted first. The address sent by the host must be consistent with that selected with the option jumpers.

Figure 5.4 Address Packet Format

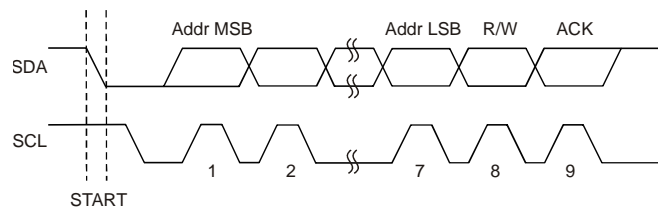

5.5 Data Packet Format

All data packets are 9 bits long, consisting of one data byte and an acknowledge bit. During a data transfer, the host generates the clock and the START and STOP conditions, while the Receiver is responsible for acknowledging the reception. An acknowledge (ACK) is signaled by the Receiver pulling the SDA line low during the ninth SCL cycle. If the Receiver leaves the SDA line high, a NACK is signaled.

5.6 Combining Address and Data Packets Into a Transmission

A transmission consists of a START condition, an SLA+R/W, one or more data packets and a STOP condition. The wired-ANDing of the SCL line is used to implement handshaking between the host and the device. The device extends the SCL low period by pulling the SCL line low whenever it needs extra time for processing between the data transmissions.

Figure 5.6 shows a typical data transmission. Note that several data bytes can be transmitted between the SLA+R/W and the STOP.

Figure 5.5 Data Packet Format

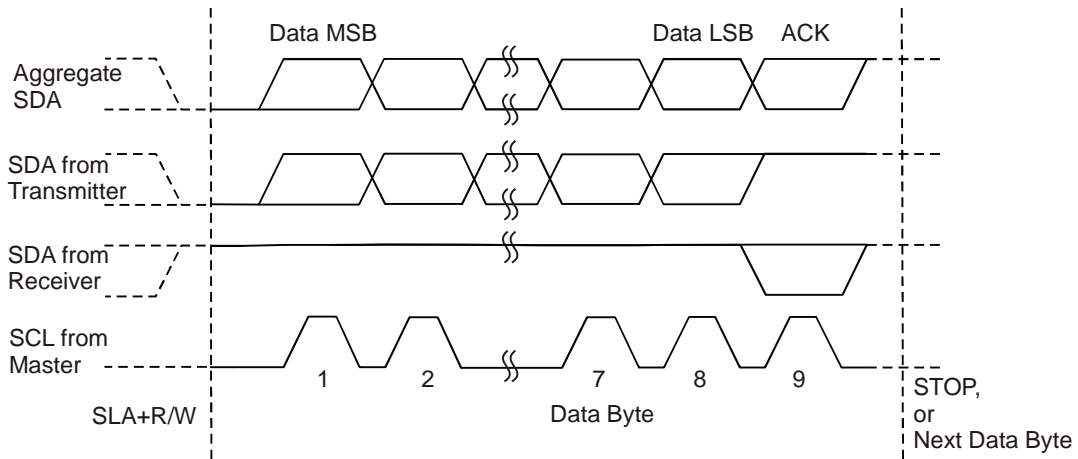
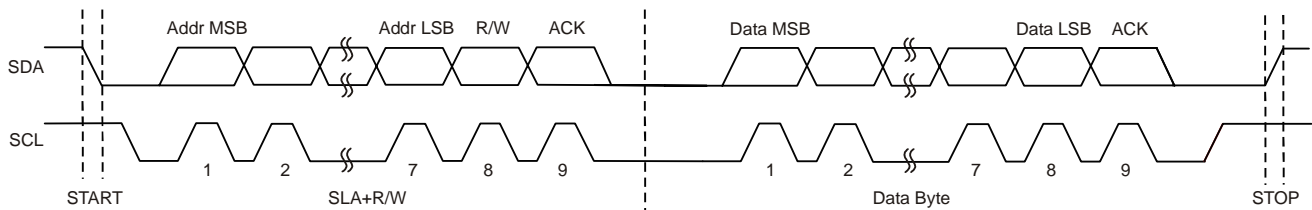

Figure 5.6 Packet Transmission



6 Setups

6.1 Introduction

The devices calibrate and process all signals using a number of algorithms specifically designed to provide for high survivability in the face of adverse environmental challenges. They provide a large number of processing options which can be user-selected to implement very flexible, robust keypad solutions.

User-defined Setups are employed to alter these algorithms to suit each application. These setups are loaded into the device over the I²C serial interfaces. The Setups are stored in an onboard EEPROM array.

Many setups employ lookup-table value translation. Table 6.2, the Setups Lookup Table on page 22 shows all translation values. The default values are the factory defaults.

Refer to Table 6.1 for all Setups.

6.2 Negative Threshold - NTHR

The negative threshold value is established relative to a key's signal reference value. The threshold is used to determine key touch when crossed by a negative-going signal swing after having been filtered by the detection integrator. Larger absolute values of threshold desensitize keys since the signal must travel farther in order to cross the threshold level. Conversely, lower thresholds make keys more sensitive.

As Cx and Cs drift, the reference point drift-compensates for these changes at a user-settable rate; the threshold level is recomputed whenever the reference point moves, and thus it also is drift compensated.

The amount of NTHR required depends on the amount of signal swing that occurs when a key is touched. Thicker panels or smaller key geometries reduce 'key gain', i.e. signal swing from touch, thus requiring smaller NTHR values to detect touch.

The negative threshold is programmed on a per-key basis using the Setup process. See Table 6.2, page 22.

Negative hysteresis: NHYST is fixed at 12.5 percent of the negative threshold value and cannot be altered.

Typical values: 3 to 8
(7 to 12 counts of threshold; 4 is internally added to NTHR to generate the threshold).

Default value: 6
(10 counts of threshold)

6.3 Positive Threshold - PTHR

The positive threshold is used to provide a mechanism for recalibration of the reference point when a key's signal moves abruptly to the positive. This condition is not normal, and usually occurs only after a recalibration when an object is touching the key and is subsequently removed. The desire is normally to recover from these events quickly.

Positive hysteresis: PHYST is fixed at 12.5 percent of the positive threshold value and cannot be altered.

Positive threshold levels are all fixed at six counts of signal and cannot be modified.

6.4 Drift Compensation - NDRIFT, PDRIFT

Signals can drift because of changes in Cx and Cs over time and temperature. It is crucial that such drift be compensated, else false detections and sensitivity shifts can occur.

Drift compensation (Figure 6.1) is performed by making the reference level track the raw signal at a slow rate, but only while there is no detection in effect. The rate of adjustment must be performed slowly, otherwise legitimate detections could be ignored. The devices drift compensate using a slew-rate limited change to the reference level; the threshold and hysteresis values are slaved to this reference.

When a finger is sensed, the signal falls since the human body acts to absorb charge from the cross-coupling between X and Y lines. An isolated, untouched foreign object (a coin, or a water film) will cause the signal to rise very slightly due to an enhancement of coupling. This is contrary to the way most capacitive sensors operate.

Once a finger is sensed, the drift compensation mechanism ceases since the signal is legitimately detecting an object. Drift compensation only works when the signal in question has not crossed the negative threshold level.

The drift compensation mechanism can be asymmetric; the drift-compensation can be made to occur in one direction faster than it does in the other simply by changing the NDRIFT and PDRIFT Setup parameters. This can be done on a per-key basis.

Figure 6.1 Thresholds and Drift Compensation

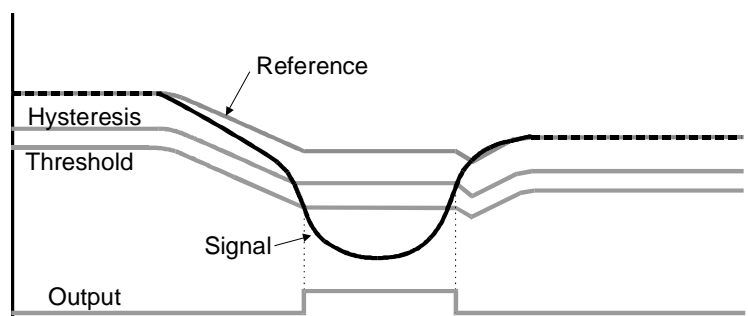

Specifically, drift compensation should be set to compensate faster for increasing signals than for decreasing signals. Decreasing signals should not be compensated quickly, since an approaching finger could be compensated for partially or entirely before even touching the touch pad. However, an obstruction over the sense pad, for which the sensor has already made full allowance, could suddenly be removed leaving the sensor with an artificially suppressed reference level and thus become insensitive to touch. In this latter case, the sensor should compensate for the object's removal by raising the reference level relatively quickly.

Drift compensation and the detection time-outs work together to provide for robust, adaptive sensing. The time-outs provide abrupt changes in reference calibration depending on the duration of the signal 'event'.

NDRIFT Typical values: 9 to 11
(2 to 3.3 seconds per count of drift compensation)

NDRIFT Default value: 10
(2.5s / count of drift compensation)

PDRIFT Typical values: 3 to 5
(0.4 to 0.8 seconds per count of drift compensation;
translation via LUT, page)

PDRIFT Default value: 4
(0.6s / count of drift compensation)

6.5 Detect Integrators - NDIL, FDIL

NDIL is used to enable or disable keys and to provide signal filtering. To enable a key, its NDIL parameter should be nonzero (ie NDIL=0 disables a key). See Section 2.2.

To suppress false detections caused by spurious events like electrical noise, the devices incorporate a 'detection integrator' or DI counter mechanism. A per-key counter is incremented each time the key has exceeded its threshold and stayed there for a number of acquisitions in succession, without going below the threshold level. When this counter reaches a preset limit the key is finally declared to be touched.

If on any acquisition the signal is not seen to exceed the threshold level, the counter is cleared and the process has to start from the beginning.

The DI mechanism uses two counters. The first is the 'fast DI' counter FDIL. When a key's signal is first noted to be below the negative threshold, the key enters 'fast burst' mode. In this mode the burst is rapidly repeated for up to the specified limit count of the fast DI counter. Each key has its own counter and its own specified fast-DI limit (FDIL), which can range from 1 to 15. When fast-burst is entered the QT device locks onto the key and repeats the acquire burst until the fast-DI counter reaches FDIL, or, the detection fails beforehand. After this the device resumes normal keyscanning and goes on to the next key.

The 'Normal DI' counter counts the number of times the fast-DI counter reached its FDIL value. The Normal DI counter can only increment once per complete scan of all keys. Only when the Normal DI counter reaches NDIL does the key become formally 'active'.

The net effect of this is that the sensor can rapidly lock onto and confirm a detection with many confirmations, while still scanning other keys. The ratio of 'fast' to 'normal' counts is completely user-settable via the Setups process. The total number of required confirmations is equal to FDIL times NDIL.

If FDIL = 5 and NDIL = 2, the total detection confirmations required is 10, even though the device only scanned through all keys only twice.

The DI is extremely effective at reducing false detections at the expense of slower reaction times. In some applications a slow reaction time is desirable. The DI can be used to intentionally slow down touch response in order to require the user to touch longer to operate the key.

If FDIL = 1, the device functions conventionally. Each channel acquires only once in rotation, and the normal detect integrator counter (NDIL) operates to confirm a detection. Fast-DI is in essence not operational.

If $FDIL \geq 2$, then the fast-DI counter also operates in addition to the NDIL counter.

If $Signal \leq NTHR$: The fast-DI counter is incremented towards FDIL due to touch.

If $Signal > NTHR$ then the fast-DI counter is cleared due to lack of touch.

Disabling a key: If NDIL = 0, the key becomes disabled. Keys disabled in this way are pared from the burst sequence in order to improve sampling rates and thus response time. See Section 2.2, page 3.

NDIL Typical values: 2, 3

NDIL Default value: 2

FDIL Typical values: 4 to 6

FDIL Default value: 5

6.6 Negative Recal Delay - NRD

If an object unintentionally contacts a key resulting in a detection for a prolonged interval it is usually desirable to recalibrate the key in order to restore its function, perhaps after a time delay of some seconds.

The Negative Recal Delay timer monitors such detections; if a detection event exceeds the timer's setting, the key will be automatically recalibrated. After a recalibration has taken place, the affected key will once again function normally even if it is still being contacted by the foreign object. This feature is set on a per-key basis using the NRD setup parameter.

NRD can be disabled by setting it to zero (infinite timeout) in which case the key will never auto-recalibrate during a continuous detection (but the host could still command it).

NRD is set using one byte per key, which can range in value from 0..254. NRD above 0 is expressed in 0.5s increments. Thus if NRD = 120, the timeout value will actually be 60 seconds. 255 is not a legal number to use.

NRD Typical values: 20 to 60 (10 to 30 seconds)

NRD Default value: 20 (10 seconds)

NRD Range: 0..254 (∞ , 0.5...127s)

NRD Accuracy: to within ± 250 ms

6.7 Positive Recalibration Delay - PRD

A recalibration occurs automatically if the signal swings more positive than the positive threshold level. This condition can occur if there is positive drift but insufficient positive drift compensation, or, if the reference moved negative due to a NRD auto-recalibration, and thereafter the signal rapidly returned to normal (positive excursion).

As an example of the latter, if a foreign object or a finger contacts a key for period longer than the Negative Recal Delay (NRD), the key is by recalibrated to a new lower reference level. Then, when the condition causing the negative swing ceases to exist (e.g. the object is removed) the signal suddenly swings positive to its normal reference.

It is almost always desirable in these cases to cause the key to recalibrate quickly so as to restore normal touch operation. The time required to do this is governed by PRD. In order for this to work, the signal must rise through the positive threshold level PTHR continuously for the PRD period.

After the PRD interval has expired and the autorecalibration has taken place, the affected key will once again function normally.

PRD Accuracy: to within ± 50 ms
Delay: PRD is fixed at 200ms for all keys, and cannot be altered.

6.8 Burst Length - BL

The signal gain for each key is controlled by circuit parameters as well as the burst length.

The burst length is simply the number of times the charge-transfer ('QT') process is performed on a given key. Each QT process is simply the pulsing of an X line once, with a corresponding Y line enabled to capture the resulting charge passed through the key's capacitance Cx.

QT60xx0 devices use a fixed number of QT cycles which are executed in burst mode. There can be up to 64 QT cycles in a burst, in accordance with the list of permitted values shown in Table 6.2, page 22.

Increasing burst length directly affects key sensitivity. This occurs because the accumulation of charge in the charge integrator is directly linked to the burst length. The burst length of each key can be set individually, allowing for direct digital control over the signal gains of each key individually.

Apparent touch sensitivity is also controlled by the Negative Threshold level (NTHR). Burst length and NTHR interact; normally burst lengths should be kept as short as possible to limit RF emissions, but NTHR should be kept above 6 to reduce false detections due to external noise. The detection integrator mechanism also helps to prevent false detections.

BL Typical values: 1, 2 (32, 48 pulses / burst)
BL Default value: 2 (48 pulses / burst)
BL Possible values: 0, 1, 2, 3 (16, 32, 48, 64 pulses/burst)

6.9 Adjacent Key Suppression - AKS

These devices incorporate adjacent key suppression ('AKS' - patent pending) that can be selected on a per-key basis. AKS permits the suppression of multiple key presses based on relative signal strength. This feature assists in solving the problem of surface moisture which can bridge a key touch to an adjacent key, causing multiple key presses. This feature is also useful for panels with tightly spaced keys, where a fingertip might inadvertently activate an adjacent key.

AKS works for keys that are AKS-enabled anywhere in the matrix and is not restricted to physically adjacent keys; the device has no knowledge of which keys are actually physically adjacent. When enabled for a key, adjacent key suppression causes detections on that key to be suppressed if any other AKS-enabled key in the panel has a more negative signal deviation from its reference.

This feature does not account for varying key gains (burst length) but ignores the actual negative detection threshold setting for the key. If AKS-enabled keys in a panel have different sizes, it may be necessary to reduce the gains of larger keys relative to smaller ones to equalize the effects of AKS. The signal threshold of the larger keys can be altered to compensate for this without causing problems with key suppression.

Adjacent key suppression works to augment the natural moisture suppression of narrow gated transfer switches creating a more robust sensing method.

AKS Default value: 0 (Off)

6.10 Oscilloscope Sync - SSYNC

Pin 11 (S_SYNC) can output a positive pulse oscilloscope sync that brackets the burst of a selected key. More than one burst can output a sync pulse as determined by the Setups parameter SSYNC for each key.

This feature is invaluable for diagnostics; without it, observing signals clearly on an oscilloscope for a particular burst is very difficult.

This function is supported in Quantum's QmBtn PC software.

SSYNC Default value: 0 (Off)

6.11 Mains Sync - MSYNC

The Mains Sync feature uses M_SYNC pin 1.

External fields can cause interference leading to false detections or sensitivity shifts. Most fields come from AC power sources. RFI noise sources are heavily suppressed by the low impedance nature of the QT circuitry itself.

Noise such as from 50Hz or 60Hz fields becomes a problem if it is uncorrelated with acquisition signal sampling; uncorrelated noise can cause aliasing effects in the key signals. To suppress this problem the M_SYNC input allows bursts to synchronize to the noise source.

The noise synchronization operating mode is set by parameter MSYNC in Setups.

The synchronization occurs only at the burst for the lowest numbered enabled key in the matrix. The device waits for the synchronization signal for up to 100ms after the end of a preceding full matrix scan, then when a negative synchronization edge is received, the matrix is scanned in its entirety again.

The sync signal drive should be a buffered logic signal, or perhaps a diode-clamped signal, but never a raw AC signal from the mains. The device will synchronize to the falling edge.

Since noise synchronization is highly effective and inexpensive to implement, it is strongly advised to take advantage of it anywhere there is a possibility of encountering low frequency (i.e. 50/60Hz) electric fields. Quantum's QmBtn software can show such noise effects on signals, and will hence assist in determining the need to make use of this feature.

If the synchronization feature is enabled but no synchronization signal exists, the sensor will continue to operate but with a delay of 100ms before the start of each matrix scan, and hence will have a slow response time.

SYNC Default value: 0 (Off)
SYNC Possible range: 0, 1 (Off, On)

6.12 Sleep Duration - SLEEP

The QT60xx0 is designed to sleep as much as possible to conserve power. Periodically, the part wakes automatically, scans the keyboard matrix and then returns to sleep. The length of time the part sleeps before automatically waking up can be configured to one of eight different values, via a look-up table. The look-up table index must be written to the setups (see Table 6.2, page 22).

Note that when a key changes state, the CHANGE pin can be made to go active and the device can go into 'fast mode' automatically if the WAKE feature is enabled on that key (next section).

SLEEP default value: 3 (125ms)
SLEEP range: 0...7 (16ms...2s)

6.13 Wake on Key Touch - WAKE

The device can be configured for full time wake-up from Sleep mode when specific keys are touched or released using this feature, in order to improve response time after each key state change. Once awake the key will remain awake until the AWAKE function times out (Section 6.14).

Also this feature makes the CHANGE pin go active on a key touch or key release (Section 3.4).

Each key has its own WAKE configuration bit so that any combination of keys can be configured for this function.

The time the part will remain awake after any key state change can also be configured in the Setup block (AWAKE feature, next section).

Any key, even one where the WAKE feature is not enabled, will prolong the time the part remains awake once the part is awake

In Shift Register mode, the WAKE function is enabled for all keys, however the CHANGE pin does not function in this mode. The AWAKE timeout in Shift Register mode is 2.5s (note default setting of AWAKE parameter in Table 6.2).

WAKE Default value: 1 (On)
WAKE Possible range: 0, 1 (Off, On)

6.14 Awake Timeout - AWAKE

After each matrix scan, the part will automatically go to sleep whenever possible to conserve power, unless there has been a key state change on a key with the WAKE feature enabled (Section 6.13), in which case the part will wake up into 'fast mode' which has no sleep states and operates at the fastest possible speed. The AWAKE timeout feature determines how long the device will remain in this mode from the last key state change.

Subsequent key state changes further prolong the AWAKE interval. In other words, once the part has been awakened by a change on a WAKE enabled key, the key response time will be fast for as long as the keyboard remains in use. Once key activity lapses for a period longer than the AWAKE timeout, the part will return to sleep mode.

The AWAKE period can be configured to a value between 100ms and 25.5s, in increments of 100ms.

AWAKE default value: 25 (2.5s)
AWAKE range: 1...255 (100ms...25.5s)
AWAKE Timeout accuracy: to within ± 50 ms

6.15 Drift Hold Time - DHT

Drift Hold Time (DHT) is used to restrict drift on all keys while one or more keys are activated. DHT defines the length of time the drift is halted after a key detection.

This feature is particularly useful in cases of high-density keypads where touching a key or hovering a finger over the keypad would cause untouched keys to drift, and therefore create a sensitivity shift, and ultimately inhibit any touch detection.

DHT can be configured to a value of between 100ms and 25.5s, in increments of 100ms. Setting this parameter to 0 will disable this feature and the drift compensation on any key will not be dependent on the state of other keys.

DHT default value: 10 (1s)
DHT range: 0...255 (Off, 100ms...25.5s)

6.16 Setups Block

Table 6.1 Setups Table

Setups data is sent from the host to the QT using the I²C interface. The setups block is memory mapped onto this interface. Thus reading/writing the appropriate address. Setups can be accessed individually or as a block. Before writing to any setup, an unlock command is sent to the host via the I²C interface. Refer also to Table 6.2, page 22 for further details, and all of Section 6.

Item	Address	Bytes	Parameter	Symbol	Valid Range	Bits	Key Scope	Default Value	Des
1	131...154	24	Neg thresh Neg Drift Comp	NTHR NDRIFT	NTHR = 0...15 NDRIFT = 0...15	4 4	1 1	6 10	Lower nibble = Neg Threshold - take operation Upper nibble = Neg Drift comp - via Lookups
2	155...178	24	Pos Drift Comp	PDRIFT	PDRIFT = 0...15	4	1	4	Upper nibble = Pos Drift comp - via LUT (1 = enabled, 0 = disabled)
3	179...202	24	Normal DI Limit Fast DI Limit	NDIL FDIL	NDIL = 0...15 FDIL = 0...15	4 4	1 1	2 5	Lower nibble = Normal DI Limit, values same as for QT60160, only the first 16 locations are used Upper nibble = Fast DI Limit, values same as for QT60160
4	203...226	24	Neg recal delay	NRD	0...254	8	1	20	Range is in 0.5 sec increments; 0 = infinite, 255 is illegal
5	227...250	24	Wake On Touch Burst Length AKS Scope Sync	WAKE BL AKS SSYNC	WAKE = 0,1 BL = 0...3 AKS = 0,1 SSYNC = 0,1	1 2 1 1	1 1 1 1	1 2 0 0	Bit 3 = WAKE, 1 - enabled Bits 5, 4 = BL, via LUT (Table 6.2 page 22) Bit 6 = AKS, 1 - enabled Bit 7 = Scope sync, 1 = enabled
6	251	1	Sleep Duration Mains Sync	SLEEP MSYNC	SLEEP = 0...7 MSYNC = 0,1	3 1	24 24	3 0	Bits 2,1,0 = Sleep Duration, 8 values via LUT Bits 6 = Mains sync, negative edge, 1 = enabled, 0 = disabled
7	252	1	Awake Timeout	AWAKE	1...255	8	24	25	Range is in 100ms increments; 1 = 100ms, 255 = infinite
8	253	1	Drift Hold Time	DHT	0...255	8	24	10	Range is in 100ms increments; 0 = disable, 255 = infinite

Table 6.2 Setups Lookup Table

Typical values: For most touch applications, use the values shown in the outlined cells. Bold text items indicate default settings. The leftmost column (0...15), not numbers from within the table. The QT uses lookup tables to translate the 0...15 to the parameters
NRD is an exception: it can range from 0...254 which is translated from 1 = 0.5s to 254 = 127s, in increments of 0.5s, with zero = in
AWAKE is an exception: it can range from 1...255 which is translated from 1 = 0.1s to 255 = 25.5s , in increments of 0.1s. Zero is ill
DHT is an exception: it can range from 0...255 which is translated from 1 = 0.1s to 255 = 25.5s , in increments of 0.1s. Zero will disa

Index Number	Parameter										
	NTHR counts (Page 17)	NDRIFT secs (Page 17)	PDRIFT secs (Page 17)	NDIL counts (Page 18)	FDIL counts (Page 18)	NRD secs (Page 18)	WAKE (Page 20)	BL Pulses (Page 19)	AKS (Page 19)	SSYNC (Page 19)	
	Per key	Per key	Per key	Per key	Per key	Per key	Per key	Per key	Per key	Per key	
0	4	0.1	0.1	Key off	unused	0 (Infinite)	Off	16	- Off -	On	
1	5	0.2	0.2	1	1	0.5 .. 127s	- On -	32	On	On	
2	6	0.3	0.3	- 2 -	2	Default= 10s		- 48 -			
3	7	0.4	0.4	3	3			64			
4	8	0.6	- 0.6 -	4	4						
5	9	0.8	0.8	5	- 5 -						
6	- 10 -	1	1	6	6						
7	11	1.2	1.2	7	7						
8	12	1.5	1.5	8	8						
9	13	2	2	9	9						
10	14	- 2.5 -	2.5	10	10						
11	15	3.3	3.3	11	11						
12	16	4.5	4.5	12	12						
13	17	6	6	13	13						
14	18	7.5	7.5	14	14						
15	19	10	10	15	15						

7 Specifications

7.1 Absolute Maximum Electrical Specifications

Operating temp.	-40°C to +85°C
Storage temp.	-55°C to +125°C
Vdd.	-0.5 to +5.5V
Max continuous pin current, any control or drive pin.	±10mA
Short circuit duration to ground, any pin.	infinite
Short circuit duration to Vdd, any pin.	infinite
Voltage forced onto any pin.	-0.6V to (Vdd + 0.6) Volts
EEPROM setups maximum writes.	100,000 write cycles

7.2 Recommended Operating Conditions

Vdd. +1.8V to 5.25V

Note: the devices will run at a minimum of 1.62V.

Supply ripple+noise. ±5mV

Cx transverse load capacitance per key. 2 to 20pF

7.3 DC Specifications

Vdd = 5.0V, Cs = 4.7nF, Rs = 470K; Ta = recommended range, unless otherwise noted

Parameter	Description	Min	Typ	Max	Units	Notes
Iddr	Average supply current, running		1.02 2.34 4.60		mA	Vdd = 1.8V Vdd = 3.3V Vdd = 5.0V
Idds	Average supply current, sleeping		3 4 6		µA	Vdd = 1.8V Vdd = 3.3V Vdd = 5.0V
Vil	Low input logic level			0.2Vdd	V	1.8V <Vdd <5V
Vhl	High input logic level	0.6Vdd			V	1.8V <Vdd <5V
Vol	Low output voltage			0.2	V	
Voh	High output voltage	4.2			V	
Iil	Input leakage current			1	µA	
Ar	Acquisition resolution		10		bits	
Rrst	Internal /RST pullup resistor			60	kΩ	

7.4 Timing Specifications

Parameter	Description	Min	Typ	Max	Units	Notes
Tbs	Burst spacing		270 380 490 600		µs	BL = 16 BL = 32 BL = 48 BL = 64
Fc	Burst center frequency		155		kHz	
Fm	Burst modulation, percentage		±10		%	

7.5 Power Consumption

Table 7.1 Average Current Consumption

Test condition: BL = 48, 16 or 24 keys enabled (see appropriate column)

Voltage (V)	Sleep Setting (ms)	Idd Typical (mA)	
		24 keys	16 keys
1.8	16	0.480	0.360
3.3		1.050	0.840
5.0		1.900	1.550
1.8	32	0.300	0.250
3.3		0.670	0.540
5.0		1.220	0.910
1.8	64	0.170	0.150
3.3		0.350	0.310
5.0		0.730	0.550
1.8	125	0.090	0.080
3.3		0.220	0.170
5.0		0.400	0.300
1.8	250	0.050	0.048
3.3		0.120	0.100
5.0		0.240	0.160
1.8	500	0.043	0.040
3.3		0.090	0.060
5.0		0.160	0.110
1.8	1000	0.040	0.038
3.3		0.080	0.053
5.0		0.130	0.100
1.8	2000	0.039	0.037
3.3		0.075	0.050
5.0		0.120	0.095

The formula to find the average current is:

$$I_{dd} = \frac{(\text{current sleeping} \times \text{sleep period}) + (\text{current running} \times (\text{burst spacing} \times \text{number of keys enabled}))}{\text{sleep period} + (\text{burst spacing} \times \text{number of keys enabled})}$$

$$I_{dd} = \frac{(I_{dds} \times T_{sleep}) + (I_{ddr} \times (T_{bs} \times KE))}{T_{sleep} + (T_{bs} \times KE)}$$

Note: there may be more than one instance of (T_{bs} x KE) (see example below)

Where:

- I_{dd} = average current (mA)
- I_{dds} = current when sleeping (mA) (Section 7.3)
- T_{sleep} = sleep period (ms) (Table 6.2)
- I_{ddr} = current when running (mA) (Section 7.3)
- T_{bs} = burst spacing¹ (ms) (Section 7.4)
- KE = number of keys enabled¹

¹ if more than one burst spacing is used then each must be included in the calculation.

Example: Conditions: V_{dd} = 1.8V, 10 keys BL = 32, 14 keys BL = 16, T_{sleep} = 125ms

$$I_{dd} = \frac{(0.003 \times 125) + (1.02 \times ((0.38 \times 10) + (0.27 \times 14)))}{125 + ((0.38 \times 10) + (0.27 \times 14))} = 0.06115\text{mA} = 61.15\mu\text{A}$$

7.6 Mechanical Dimensions

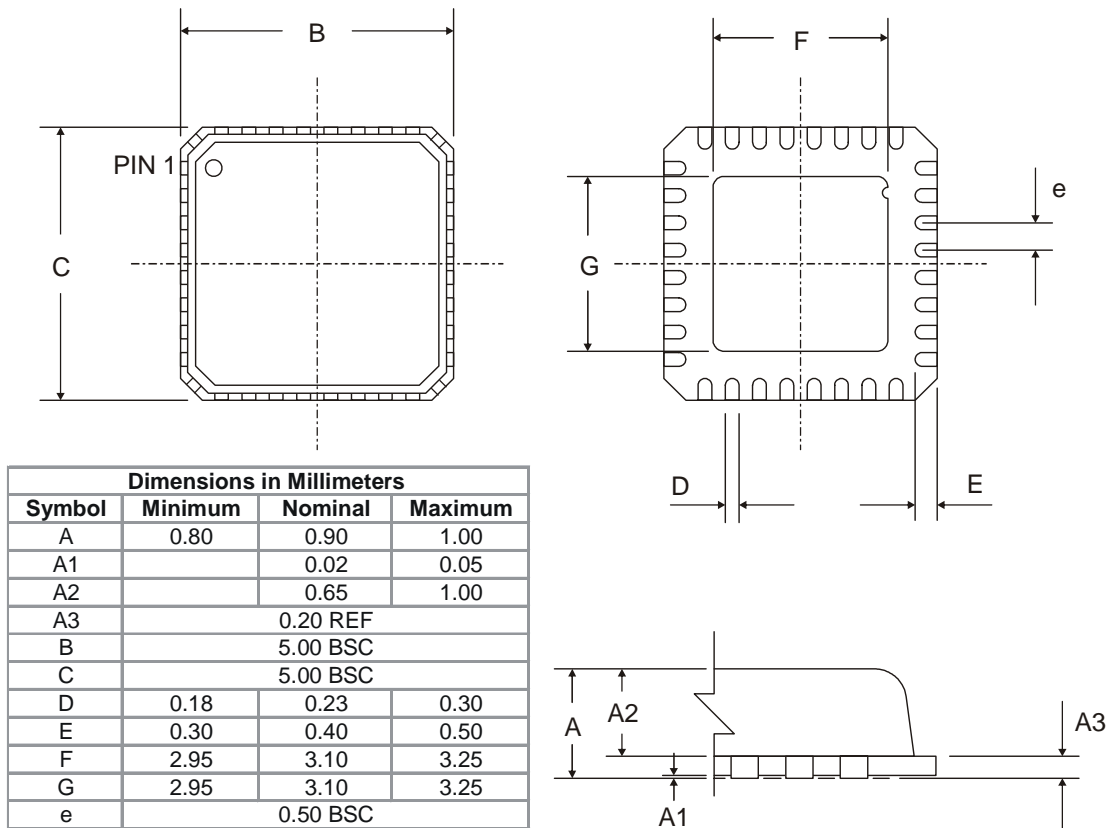

7.7 Marking

MLF Part Number	Keys	Marking
QT60160-ISG	16	6160
QT60240-ISG	24	6240

7.8 Moisture Sensitivity Level (MSL)

MSL Rating	Peak Body Temperature	Specifications
MSL3	260°C	IPC/JEDEC J-STD-020C



Copyright © 2006 QRG Ltd. All rights reserved
Patented and patents pending

Corporate Headquarters

1 Mitchell Point
Ensign Way, Hamble SO31 4RF
Great Britain

Tel: +44 (0)23 8056 5600 Fax: +44 (0)23 8045 3939

www.qprox.com

North America

651 Holiday Drive Bldg. 5 / 300
Pittsburgh, PA 15220 USA
Tel: 412-391-7367 Fax: 412-291-1015

This device is covered under one or more United States and corresponding international patents. QRG patent numbers can be found online at www.qprox.com. Numerous further patents are pending, which may apply to this device or the applications thereof.

The specifications set out in this document are subject to change without notice. All products sold and services supplied by QRG are subject to our Terms and Conditions of sale and supply of services which are available online at www.qprox.com and are supplied with every order acknowledgement. QRG trademarks can be found online at www.qprox.com. QRG products are not suitable for medical (including lifesaving equipment), safety or mission critical applications or other similar purposes. Except as expressly set out in QRG's Terms and Conditions, no licenses to patents or other intellectual property of QRG (express or implied) are granted by QRG in connection with the sale of QRG products or provision of QRG services. QRG will not be liable for customer product design and customers are entirely responsible for their products and applications which incorporate QRG's products.





Development Team: Samuel Brunet, Dr. Tim Ingersoll, Matthew Trend

Looking for pricing, stock, or lifecycle information?

Click below to explore more details on WIN SOURCE:

-  [View QT60160-ISG on WIN SOURCE](#)
-  [Microchip Technology](#) Information

Optimize Your Supply Chain with WIN SOURCE Solutions

-  Global Sourcing Solution
-  Obsolete Management
-  Cost Control Management
-  Shortage Management
-  Alternative Solution
-  Excess Inventory Management