



THE DATASHEET OF NBSG16VSMN



NBSG16VS

2.5V/3.3V SiGe Differential Receiver/Driver with Variable Output Swing

Description

The NBSG16VS is a differential receiver/driver targeted for high frequency applications that require variable output swing. The device is functionally equivalent to the EP16VS device with much higher bandwidth and lower EMI capabilities. This device may be used for applications driving VCSEL lasers.

Inputs incorporate internal 50 Ω termination resistors and accept NECL (Negative ECL), PECL (Positive ECL), LVTTTL, LVCMOS, CML, or LVDS. The output amplitude is varied by applying a voltage to the V_{CTRL} input pin. Outputs are variable swing ECL from 100 mV to 750 mV amplitude, optimized for operation from $V_{CC} - V_{EE} = 3.0$ V to 3.465 V.

The V_{BB} and V_{MM} pins are internally generated voltage supplies available to this device only. The V_{BB} is used as a reference voltage for single-ended NECL or PECL inputs and the V_{MM} pin is used as a reference voltage for LVCMOS inputs. For single-ended input operation, the unused complementary differential input is connected to V_{BB} or V_{MM} as a switching reference voltage. V_{BB} or V_{MM} may also rebias AC-coupled inputs. When used, decouple V_{BB} and V_{MM} via a 0.01 μ F capacitor and limit current sourcing or sinking to 0.5 mA. When not used, V_{BB} and V_{MM} outputs should be left open.

Features

- Maximum Input Clock Frequency up to 12 GHz Typical
- Maximum Input Data Rate up to 12 Gb/s Typical
- 40 ps Typical Rise and Fall Times ($V_{CTRL} = V_{CC} - 1$ V)
- 120 ps Typical Propagation Delay ($V_{CTRL} = V_{CC} - 1$ V)
- Variable Swing PECL Output with Operating Range: $V_{CC} = 2.375$ V to 3.465 V with $V_{EE} = 0$ V
- Variable Swing NECL Output with NECL Inputs with Operating Range: $V_{CC} = 0$ V with $V_{EE} = -2.375$ V to -3.465 V
- Output Level (100 mV to 750 mV Peak-to-Peak Output; $V_{CC} - V_{EE} = 3.0$ V to 3.465 V), Differential Output Only
- 50 Ω Internal Input Termination Resistors
- Compatible with Existing 2.5 V/3.3 V EP Devices
- V_{BB} and V_{MM} Reference Voltage Output
- Pb-Free Packages are Available



ON Semiconductor®

<http://onsemi.com>

MARKING DIAGRAMS*

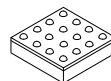

FCBGA-16
BA SUFFIX
CASE 489

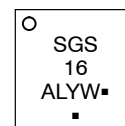

QFN-16
MN SUFFIX
CASE 485G

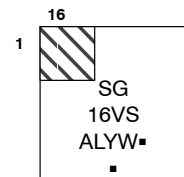

- A = Assembly Location
- L = Wafer Lot
- Y = Year
- W = Work Week
- = Pb-Free Package

(Note: Microdot may be in either location)

*For additional marking information, refer to Application Note AND8002/D.

ORDERING INFORMATION

See detailed ordering and shipping information in the package dimensions section on page 12 of this data sheet.

NBSG16VS

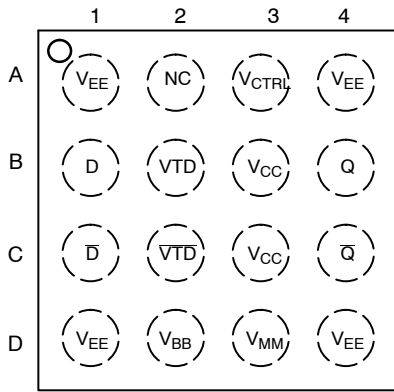

Figure 1. BGA-16 Pinout (Top View)

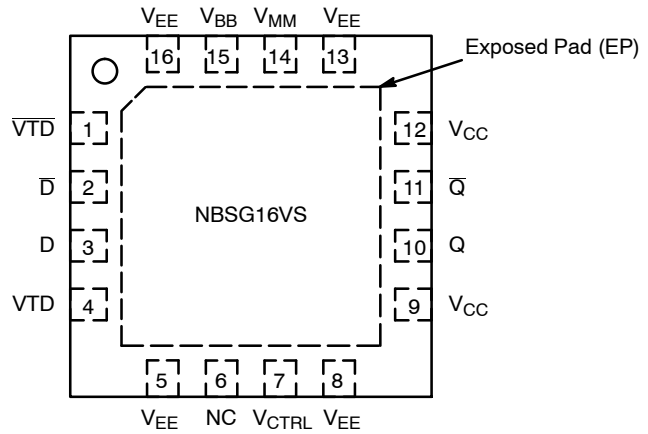

Figure 2. QFN-16 Pinout (Top View)

Table 1. PIN DESCRIPTION

Pin		Name	I/O	Description
BGA	QFN			
C2	1	VTD	-	Internal 50 Ω Termination Pin. See Table 2.
C1	2	D-bar	ECL, CML, LVCMOS, LVDS, LVTTTL Input	Inverted Differential Input. Internal 75 k Ω to V _{EE} and 36.5 k Ω to V _{CC} .
B1	3	D	ECL, CML, LVCMOS, LVDS, LVTTTL Input	Noninverted Differential Input. Internal 75 k Ω to V _{EE} .
B2	4	VTD	-	Internal 50 Ω Termination Pin. See Table 2.
A1,D1,A4, D4	5,8,13,16	V _{EE}	-	Negative Supply Voltage
A2	6	NC	-	No Connect
A3	7	V _{CTRL}		Output Amplitude Swing Control. Bypass Pin to V _{CC} through 0.1 μ F Capacitor.
B3,C3	9,12	V _{CC}	-	Positive Supply Voltage
B4	10	Q	RSECL Output	Noninverted Differential Output. Typically Terminated with 50 Ω to V _{TT} = V _{CC} - 2 V
C4	11	Q-bar	RSECL Output	Inverted Differential Output. Typically Terminated with 50 Ω to V _{TT} = V _{CC} - 2 V
D3	14	V _{MM}	-	LVCMOS Reference Voltage Output. (V _{CC} - V _{EE})/2
D2	15	V _{BB}	-	ECL Reference Voltage Output
N/A	-	EP	-	The Exposed Pad (EP) and the QFN-16 package bottom is thermally connected to the die for improved heat transfer out of package. The exposed pad must be attached to a heat-sinking conduit. The pad is not electrically connected to the die but may be electrically and thermally connected to V _{EE} on the PC board.

1. The NC pin is electrically connected to the die and must be left open.
2. All V_{CC} and V_{EE} pins must be externally connected to Power Supply to guarantee proper operation. The thermally exposed pad on package bottom (see case drawing) must be attached to a heat-sinking conduit.
3. In the differential configuration when the input termination pins (VTD, VTD) are connected to a common termination voltage, and if no signal is applied then the device will be susceptible to self-oscillation.

NBSG16VS

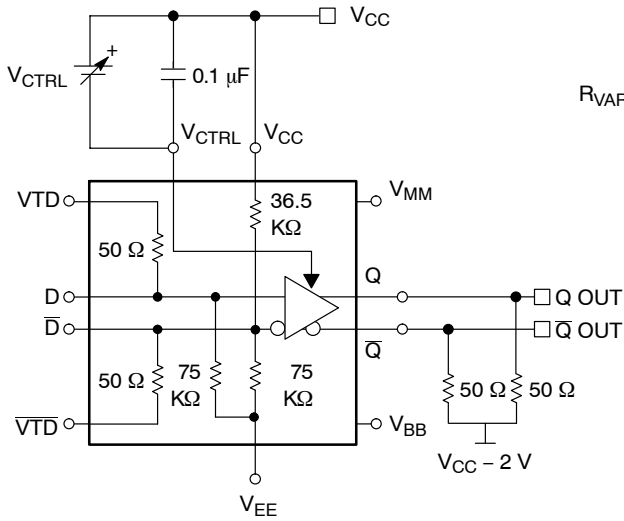

**Figure 3. Logic Diagram/
Voltage Source Implementation**

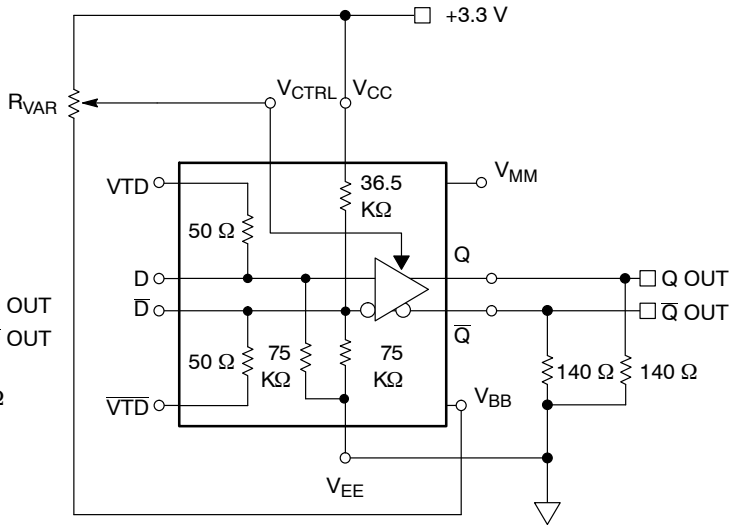

Figure 4. Alternative Voltage Source Implementation

Table 2. INTERFACING OPTIONS

INTERFACING OPTIONS	CONNECTIONS
CML	Connect VTD and \overline{VTD} to V_{CC}
LVDS	Connect VTD and \overline{VTD} Together
AC-COUPLED	Bias VTD and \overline{VTD} Inputs within Common Mode Range (V_{IHCMR})
RSECL, PECL, NECL	Standard ECL Termination Techniques
LVTTTL	An external voltage should be applied to the unused complementary differential input. Nominal voltage is 1.5 V for LVTTTL.
LVC MOS	V_{MM} should be connected to the unused complementary differential input.

NBSG16VS

Table 3. ATTRIBUTES

Characteristics		Value	
Internal Input Pulldown Resistor (D, \bar{D})		75 k Ω	
Internal Input Pullup Resistor (\bar{D})		36.5 k Ω	
ESD Protection		Human Body Model	> 2 kV
		Machine Model	> 100 V
Moisture Sensitivity (Note 4)		Pb Pkg	Pb-Free Pkg
		FCBGA-16	Level 3
		QFN-16	Level 1
Flammability Rating		Oxygen Index: 28 to 34	UL 94 V-0 @ 0.125 in
Transistor Count		192	
Meets or exceeds JEDEC Spec EIA/JESD78 IC Latchup Test			

4. For additional information, see Application Note AND8003/D.

Table 4. MAXIMUM RATINGS

Symbol	Parameter	Condition 1	Condition 2	Rating	Unit
V _{CC}	Positive Power Supply	V _{EE} = 0 V		3.6	V
V _{EE}	Negative Power Supply	V _{CC} = 0 V		-3.6	V
V _I	Positive Input Negative Input	V _{EE} = 0 V V _{CC} = 0 V	V _I ≤ V _{CC} V _I ≥ V _{EE}	3.6 -3.6	V V
V _{INPP}	Differential Input Voltage D - \bar{D}	V _{CC} - V _{EE} ≥ 2.8 V V _{CC} - V _{EE} < 2.8 V		2.8 V _{CC} - V _{EE}	V V
I _{OUT}	Output Current	Continuous Surge		25 50	mA mA
I _{IN}	Input Current Through R _T (50 Ω Resistor)	Static Surge		45 80	mA mA
I _{BB}	V _{BB} Sink/Source			1	mA
I _{MM}	V _{MM} Sink/Source			1	mA
T _A	Operating Temperature Range			-40 to +85	°C
T _{stg}	Storage Temperature Range			-65 to +150	°C
θ_{JA}	Thermal Resistance (Junction-to-Ambient) (Note 5)	0 lfpm 500 lfpm 0 lfpm 500 lfpm	FCBGA-16 FCBGA-16 QFN-16 QFN-16	108 86 41.6 35.2	°C/W
θ_{JC}	Thermal Resistance (Junction-to-Case)	2S2P (Note 5) 2S2P (Note 6)	FCBGA-16 QFN-16	5.0 4.0	°C/W °C/W
T _{sol}	Wave Solder	Pb Pb-Free		225 265	°C

Stresses exceeding Maximum Ratings may damage the device. Maximum Ratings are stress ratings only. Functional operation above the Recommended Operating Conditions is not implied. Extended exposure to stresses above the Recommended Operating Conditions may affect device reliability.

5. JEDEC standard 51-6 multilayer board - 2S2P (2 signal, 2 power).

6. JEDEC standards multilayer board - 2S2P (2 signal, 2 power) with 8 filled thermal vias under exposed pad.

NBSG16VS

Table 5. DC CHARACTERISTICS, INPUT WITH VARIABLE PECL OUTPUT $V_{CC} = 2.5\text{ V}$; $V_{EE} = 0\text{ V}$ (Note 7)

Symbol	Characteristic	-40°C			25°C			85°C			Unit
		Min	Typ	Max	Min	Typ	Max	Min	Typ	Max	
I_{EE}	Negative Power Supply Current	18	25	32	18	25	32	18	25	32	mA
V_{OH}	Output HIGH Voltage (Note 8)	1315	1440	1565	1305	1430	1555	1305	1430	1555	mV
V_{OL}	Output LOW Voltage (Note 8) (Max Swing) ($V_{CTRL} = V_{CC} - 600\text{ mV}$)	645 1090	765 1210	885 1330	605 1035	725 1155	845 1275	600 1010	720 1130	840 1250	mV
V_{IH}	Input HIGH Voltage (Single-Ended) (Notes 10 and 11)	$V_{THR} + 75$	$V_{CC} - 1000^*$	V_{CC}	$V_{THR} + 75$	$V_{CC} - 1000^*$	V_{CC}	$V_{THR} + 75$	$V_{CC} - 1000^*$	V_{CC}	mV
V_{IL}	Input LOW Voltage (Single-Ended) (Notes 10 and 12)	$V_{IH} - 2500$	$V_{CC} - 1400^*$	$V_{THR} - 75$	$V_{IH} - 2500$	$V_{CC} - 1400^*$	$V_{THR} - 75$	$V_{IH} - 2500$	$V_{CC} - 1400^*$	$V_{THR} - 75$	mV
V_{BB}	PECL Output Voltage Reference	1080	1140	1200	1080	1140	1200	1080	1140	1200	mV
V_{IHCMR}	Input HIGH Voltage Common Mode Range (Note 9) (Differential Configuration)	1.2		2.5	1.2		2.5	1.2		2.5	V
V_{MM}	CMOS Output Voltage Reference ($(V_{CC} - V_{EE})/2$)	1100	1250	1400	1100	1250	1400	1100	1250	1400	mV
R_{TIN}	Internal Input Termination Resistor	45	50	55	45	50	55	45	50	55	Ω
I_{IH}	Input HIGH Current (@ V_{IH})		30	100		30	100		30	100	μA
I_{IL}	Input LOW Current (@ V_{IL})		25	50		25	50		25	50	μA

NOTE: Device will meet the specifications after thermal equilibrium has been established when mounted in a test socket or printed circuit board with maintained transverse airflow greater than 500 lfm. Electrical parameters are guaranteed only over the declared operating temperature range. Functional operation of the device exceeding these conditions is not implied. Device specification limit values are applied individually under normal operating conditions and not valid simultaneously.

*Typicals used for testing purposes.

7. Input and output parameters vary 1:1 with V_{CC} . V_{EE} can vary +0.125 V to -0.965 V.

8. All loading with 50 Ω to $V_{CC} - 2.0\text{ V}$. V_{OH}/V_{OL} measured at V_{IH}/V_{IL} .

9. V_{IHCMR} min varies 1:1 with V_{EE} ; V_{IHCMR} max varies 1:1 with V_{CC} . The V_{IHCMR} range is referenced to the most positive side of the differential input signal.

10. V_{THR} is the voltage applied to the complementary input, typically V_{BB} or V_{MM} . $V_{THR(MIN)} = V_{IHCMR} + 75\text{ mV}$. $V_{THR(MAX)} = V_{IHCMR} - 75\text{ mV}$.

11. V_{IH} cannot exceed V_{CC} .

12. V_{IL} always $\geq V_{EE}$.

NBSG16VS

Table 6. DC CHARACTERISTICS, INPUT WITH VARIABLE PECL OUTPUT $V_{CC} = 3.3\text{ V}$; $V_{EE} = 0\text{ V}$ (Note 18)

Symbol	Characteristic	-40°C			25°C			85°C			Unit
		Min	Typ	Max	Min	Typ	Max	Min	Typ	Max	
I_{EE}	Negative Power Supply Current	20	27	34	20	27	34	20	27	34	mA
V_{OH}	Output HIGH Voltage (Note 13)	2095	2220	2345	2085	2210	2335	2075	2200	2325	mV
V_{OL}	Output LOW Voltage (Note 13) (Max Swing) ($V_{CTRL} = V_{CC} - 600\text{ mV}$)	1275 1750	1395 1870	1515 1990	1285 1730	1405 1850	1525 1970	1295 1715	1415 1835	1535 1955	mV
V_{IH}	Input HIGH Voltage (Single-Ended) (Notes 15 and 16)	$V_{THR} + 75$	$V_{CC} - 1000^*$	V_{CC}	$V_{THR} + 75$	$V_{CC} - 1000^*$	V_{CC}	$V_{THR} + 75$	$V_{CC} - 1000^*$	V_{CC}	mV
V_{IL}	Input LOW Voltage (Single-Ended) (Notes 15 and 17)	$V_{IH} - 2500$	$V_{CC} - 1400^*$	$V_{THR} - 75$	$V_{IH} - 2500$	$V_{CC} - 1400^*$	$V_{THR} - 75$	$V_{IH} - 2500$	$V_{CC} - 1400^*$	$V_{THR} - 75$	mV
V_{BB}	PECL Output Voltage Reference	1880	1940	2000	1880	1940	2000	1880	1940	2000	mV
V_{IHCMR}	Input HIGH Voltage Common Mode Range (Note 14) (Differential Configuration)	1.2		3.3	1.2		3.3	1.2		3.3	V
V_{MM}	CMOS Output Voltage Reference ($(V_{CC} - V_{EE})/2$)	1500	1650	1800	1500	1650	1800	1500	1650	1800	mV
R_{TIN}	Internal Input Termination Resistor	45	50	55	45	50	55	45	50	55	Ω
I_{IH}	Input HIGH Current (@ V_{IH})		30	100		30	100		30	100	μA
I_{IL}	Input LOW Current (@ V_{IL})		25	50		25	50		25	50	μA

NOTE: Device will meet the specifications after thermal equilibrium has been established when mounted in a test socket or printed circuit board with maintained transverse airflow greater than 500 lpm. Electrical parameters are guaranteed only over the declared operating temperature range. Functional operation of the device exceeding these conditions is not implied. Device specification limit values are applied individually under normal operating conditions and not valid simultaneously.

*Typicals used for testing purposes.

13. All loading with 50 Ω to $V_{CC} - 2.0\text{ V}$. V_{OH}/V_{OL} measured at V_{IH}/V_{IL} .

14. V_{IHCMR} min varies 1:1 with V_{EE} . V_{IHCMR} max varies 1:1 with V_{CC} . The V_{IHCMR} range is referenced to the most positive side of the differential input signal.

15. V_{THR} is the voltage applied to the complementary input, typically V_{BB} or V_{MM} . $V_{THR(MIN)} = V_{IHCMR} + 75\text{ mV}$. $V_{THR(MAX)} = V_{IHCMR} - 75\text{ mV}$.

16. V_{IH} cannot exceed V_{CC} .

17. V_{IL} always $\geq V_{EE}$.

18. Input and output parameters vary 1:1 with V_{CC} . V_{EE} can vary +0.925 V to -0.165 V.

NBSG16VS

Table 7. DC CHARACTERISTICS, NECL INPUT WITH VARIABLE NECL OUTPUT

$V_{CC} = 0\text{ V}$; $V_{EE} = -3.465\text{ V}$ to -2.375 V (Note 19)

Symbol	Characteristic	-40°C			25°C			85°C			Unit
		Min	Typ	Max	Min	Typ	Max	Min	Typ	Max	
I_{EE}	Negative Power Supply Current	20	27	34	20	27	34	20	27	34	mA
V_{OH}	Output HIGH Voltage (Note 20) $-3.465\text{ V} \leq V_{EE} \leq -3.0\text{ V}$ $-3.0\text{ V} < V_{EE} \leq -2.375\text{ V}$	-1205 -1185	-1080 -1060	-955 -935	-1215 -1195	-1090 -1070	-965 -945	-1225 -1195	-1100 -1070	-975 -945	mV
V_{OL}	Output LOW Voltage (Note 20) $-3.465\text{ V} \leq V_{EE} \leq -3.0\text{ V}$ (Max Swing) $(V_{CTRL} = V_{CC} - 600\text{ mV})$ $-3.0\text{ V} < V_{EE} \leq -2.375\text{ V}$ (Max Swing) $(V_{CTRL} = V_{CC} - 600\text{ mV})$	-2000 -1560	-1910 -1440	-1820 -1320	-1990 -1580	-1900 -1460	-1810 -1340	-1980 -1595	-1890 -1475	-1800 -1355	mV
		-1855 -1410	-1620 -1215	-1290 -1000	-1895 -1460	-1705 -1290	-1425 -1100	-1900 -1490	-1730 -1330	-1470 -1150	mV
V_{IH}	Input HIGH Voltage (Single-Ended) (Notes 22 and 23)	$V_{THR} + 75$	$V_{CC} - 1000^*$	V_{CC}	$V_{THR} + 75$	$V_{CC} - 1000^*$	V_{CC}	$V_{THR} + 75$	$V_{CC} - 1000^*$	V_{CC}	mV
V_{IL}	Input LOW Voltage (Single-Ended) (Notes 22 and 24)	$V_{IH} - 2500$	$V_{CC} - 1400^*$	$V_{THR} - 75$	$V_{IH} - 2500$	$V_{CC} - 1400^*$	$V_{THR} - 75$	$V_{IH} - 2500$	$V_{CC} - 1400^*$	$V_{THR} - 75$	mV
V_{BB}	NECL Output Voltage Reference	-1420	-1360	-1300	-1420	-1360	-1300	-1420	-1360	-1300	mV
V_{IHCMR}	Input HIGH Voltage Common Mode Range (Note 21) (Differential Configuration)	$V_{EE} + 1.2$		0.0	$V_{EE} + 1.2$		0.0	$V_{EE} + 1.2$		0.0	V
V_{MM}	CMOS Output Voltage Reference (Note 25)	$V_{MMT} - 150$	V_{MMT}	$V_{MMT} + 150$	$V_{MMT} - 150$	V_{MMT}	$V_{MMT} + 150$	$V_{MMT} - 150$	V_{MMT}	$V_{MMT} + 150$	mV
R_{TIN}	Internal Input Termination Resistor	45	50	55	45	50	55	45	50	55	Ω
I_{IH}	Input HIGH Current (@ V_{IH})		30	100		30	100		30	100	μA
I_{IL}	Input LOW Current (@ V_{IL})		25	50		25	50		25	50	μA

NOTE: Device will meet the specifications after thermal equilibrium has been established when mounted in a test socket or printed circuit board with maintained transverse airflow greater than 500 lpm. Electrical parameters are guaranteed only over the declared operating temperature range. Functional operation of the device exceeding these conditions is not implied. Device specification limit values are applied individually under normal operating conditions and not valid simultaneously.

*Typicals used for testing purposes.

19. Input and output parameters vary 1:1 with V_{CC} .

20. All loading with $50\ \Omega$ to $V_{CC} - 2.0\text{ V}$. V_{OH}/V_{OL} measured at V_{IH}/V_{IL} .

21. V_{IHCMR} min varies 1:1 with V_{EE} , V_{IHCMR} max varies 1:1 with V_{CC} . The V_{IHCMR} range is referenced to the most positive side of the differential input signal.

22. V_{THR} is the voltage applied to the complementary input, typically V_{BB} or V_{MM} . $V_{THR(MIN)} = V_{IHCMR} + 75\text{ mV}$. $V_{THR(MAX)} = V_{IHCMR} - 75\text{ mV}$.

23. V_{IH} cannot exceed V_{CC} .

24. V_{IL} always $\geq V_{EE}$.

25. V_{MM} typical = $|V_{CC} - V_{EE}| / 2 + V_{EE} = V_{MMT}$.

NBSG16VS

Table 8. AC CHARACTERISTICS for FCBGA-16 $V_{CC} = 0\text{ V}$; $V_{EE} = -3.465\text{ V to }-3.0\text{ V}$ or $V_{CC} = 3.0\text{ V to }3.465\text{ V}$; $V_{EE} = 0\text{ V}$

Symbol	Characteristic	-40°C			25°C			85°C			Unit
		Min	Typ	Max	Min	Typ	Max	Min	Typ	Max	
f_{max}	Maximum Frequency (See Figure 8) (Note 26)	10.7 (Note 29)	12		10.7 (Note 29)	12		10.7 (Note 29)	12		GHz
t_{PLH} , t_{PHL}	Propagation Delay to Output Differential $(V_{CTRL} = V_{CC} - 2\text{ V}) D \rightarrow Q, \bar{Q}$ $(V_{CTRL} = V_{CC} - 1\text{ V}) D \rightarrow Q, \bar{Q}$	100 100	125 120	145 140	100 100	125 120	145 140	100 100	125 120	145 140	ps
t_{SKEW}	Duty Cycle Skew (Note 27)		3	10		3	10		3	10	ps
t_{JITTER}	RMS Random Clock Jitter $f_{in} < 10\text{ GHz}$ Peak-to-Peak Data Dependent Jitter $f_{in} < 10\text{ Gb/s}$		0.8 TBD	2		0.8 TBD	2		0.8 TBD	2	ps
V_{INPP}	Input Voltage Swing/Sensitivity (Differential Configuration) (Note 28)	75		2600	75		2600	75		2600	mV
t_r t_f	Output Rise/Fall Times (20% - 80%) @ 1 GHz $(V_{CTRL} = V_{CC} - 2\text{ V}) Q, \bar{Q}$ $(V_{CTRL} = V_{CC} - 1\text{ V}) Q, \bar{Q}$	30 30	45 40	55 50	30 30	45 40	55 50	30 30	45 40	55 50	ps

NOTE: Device will meet the specifications after thermal equilibrium has been established when mounted in a test socket or printed circuit board with maintained transverse airflow greater than 500 lfm. Electrical parameters are guaranteed only over the declared operating temperature range. Functional operation of the device exceeding these conditions is not implied. Device specification limit values are applied individually under normal operating conditions and not valid simultaneously.

26. Measured using a 500 mV source, 50% duty cycle clock source. All loading with $50\ \Omega$ to $V_{CC} - 2.0\text{ V}$. Input edge rates 40 ps (20% - 80%).

27. $t_{SKEW} = |t_{PLH} - t_{PHL}|$ for a nominal 50% differential clock input waveform. See Figure 10.

28. $V_{INPP(MAX)}$ cannot exceed $V_{CC} - V_{EE}$ (applicable only when $V_{CC} - V_{EE} < 2600\text{ mV}$).

29. Conditions include input amplitude of 500 mV and $V_{CTRL} = V_{CC} - 2\text{ V}$. Minimum output amplitude guarantee of 100 mV (see Output P-P Spec in Figure 8).

Table 9. AC CHARACTERISTICS for FCBGA-16 $V_{CC} = 0\text{ V}$; $-3.0\text{ V} < V_{EE} \leq -2.375\text{ V}$ or $2.375\text{ V} \leq V_{CC} < 3.0\text{ V}$; $V_{EE} = 0\text{ V}$

Symbol	Characteristic	-40°C			25°C			85°C			Unit
		Min	Typ	Max	Min	Typ	Max	Min	Typ	Max	
f_{max}	Maximum Frequency (See Figure 9) (Note 30)	10.7 (Note 33)	12		10.7 (Note 33)	12		10.7 (Note 33)	12		GHz
t_{PLH} , t_{PHL}	Propagation Delay to Output Differential $(V_{CTRL} = V_{CC} - 2\text{ V}) D \rightarrow Q, \bar{Q}$ $(V_{CTRL} = V_{CC} - 1\text{ V}) D \rightarrow Q, \bar{Q}$	100 100	125 120	145 140	100 100	125 120	145 140	100 100	125 120	145 140	ps
t_{SKEW}	Duty Cycle Skew (Note 31)		3	10		3	10		3	10	ps
t_{JITTER}	RMS Random Clock Jitter $f_{in} < 10\text{ GHz}$ Peak-to-Peak Data Dependent Jitter $f_{in} < 10\text{ Gb/s}$		0.9 TBD	3		0.9 TBD	3		0.9 TBD	3	ps
V_{INPP}	Input Voltage Swing/Sensitivity (Differential Configuration) (Note 32)	75		2600	75		2600	75		2600	mV
t_r t_f	Output Rise/Fall Times (20% - 80%) @ 1 GHz $(V_{CTRL} = V_{CC} - 2\text{ V}) Q, \bar{Q}$ $(V_{CTRL} = V_{CC} - 1\text{ V}) Q, \bar{Q}$	25 22	50 45	70 60	25 22	50 45	70 60	25 22	50 45	70 60	ps

NOTE: Device will meet the specifications after thermal equilibrium has been established when mounted in a test socket or printed circuit board with maintained transverse airflow greater than 500 lfm. Electrical parameters are guaranteed only over the declared operating temperature range. Functional operation of the device exceeding these conditions is not implied. Device specification limit values are applied individually under normal operating conditions and not valid simultaneously.

30. Measured using a 500 mV source, 50% duty cycle clock source. All loading with $50\ \Omega$ to $V_{CC} - 2.0\text{ V}$. Input edge rates 40 ps (20% - 80%).

31. $t_{SKEW} = |t_{PLH} - t_{PHL}|$ for a nominal 50% differential clock input waveform. See Figure 10.

32. $V_{INPP(MAX)}$ cannot exceed $V_{CC} - V_{EE}$ (applicable only when $V_{CC} - V_{EE} < 2600\text{ mV}$).

33. Conditions include input amplitude of 500 mV and $V_{CTRL} = V_{CC} - 2\text{ V}$. Minimum output amplitude guarantee of 100 mV (see Output P-P Spec in Figure 9).

NBSG16VS

Table 10. AC CHARACTERISTICS for QFN-16 $V_{CC} = 0\text{ V}$; $V_{EE} = -3.465\text{ V}$ to -3.0 V or $V_{CC} = 3.0\text{ V}$ to 3.465 V ; $V_{EE} = 0\text{ V}$

Symbol	Characteristic	-40°C			25°C			85°C			Unit
		Min	Typ	Max	Min	Typ	Max	Min	Typ	Max	
f_{max}	Maximum Frequency (See Figure 8) (Note 34)	10 (Note 37)	12		10 (Note 37)	12		10 (Note 37)	12		GHz
t_{PLH} , t_{PHL}	Propagation Delay to Output Differential $(V_{CTRL} = V_{CC} - 2\text{ V}) D \rightarrow Q, \bar{Q}$ $(V_{CTRL} = V_{CC} - 1\text{ V}) D \rightarrow Q, \bar{Q}$	100 100	140 135	180 180	100 100	140 135	180 180	100 80	140 135	180 220	ps
t_{SKEW}	Duty Cycle Skew (Note 35)		3	20		3	15		3	10	ps
t_{JITTER}	RMS Random Clock Jitter $f_{in} < 10\text{ GHz}$ Peak-to-Peak Data Dependent Jitter $f_{in} < 10\text{ Gb/s}$		0.5 TBD	2		0.5 TBD	2		0.5 TBD	2	ps
V_{INPP}	Input Voltage Swing/Sensitivity (Differential Configuration) (Note 36)	75		2600	75		2600	75		2600	mV
t_r t_f	Output Rise/Fall Times (20% – 80%) @ 1 GHz $(V_{CTRL} = V_{CC} - 2\text{ V}) Q, \bar{Q}$ $(V_{CTRL} = V_{CC} - 1\text{ V}) Q, \bar{Q}$	30 30	45 40	55 50	30 30	45 40	55 50	30 30	45 40	55 50	ps

NOTE: Device will meet the specifications after thermal equilibrium has been established when mounted in a test socket or printed circuit board with maintained transverse airflow greater than 500 lfm. Electrical parameters are guaranteed only over the declared operating temperature range. Functional operation of the device exceeding these conditions is not implied. Device specification limit values are applied individually under normal operating conditions and not valid simultaneously.

34. Measured using a 500 mV source, 50% duty cycle clock source. All loading with $50\ \Omega$ to $V_{CC} - 2.0\text{ V}$. Input edge rates 40 ps (20% – 80%).

35. $t_{SKEW} = |t_{PLH} - t_{PHL}|$ for a nominal 50% differential clock input waveform. See Figure 10.

36. $V_{INPP(MAX)}$ cannot exceed $V_{CC} - V_{EE}$ (applicable only when $V_{CC} - V_{EE} < 2600\text{ mV}$).

37. Conditions include input amplitude of 500 mV and $V_{CTRL} = V_{CC} - 2\text{ V}$. Minimum output amplitude guarantee of 100 mV (see Output P-P Spec in Figure 8).

Table 11. AC CHARACTERISTICS for QFN-16 $V_{CC} = 0\text{ V}$; $-3.0\text{ V} < V_{EE} \leq -2.375\text{ V}$ or $2.375\text{ V} \leq V_{CC} < 3.0\text{ V}$; $V_{EE} = 0\text{ V}$

Symbol	Characteristic	-40°C			25°C			85°C			Unit
		Min	Typ	Max	Min	Typ	Max	Min	Typ	Max	
f_{max}	Maximum Frequency (See Figure 9) (Note 38)	10 (Note 41)	12		10 (Note 41)	12		10 (Note 41)	12		GHz
t_{PLH} , t_{PHL}	Propagation Delay to Output Differential $(V_{CTRL} = V_{CC} - 2\text{ V}) D \rightarrow Q, \bar{Q}$ $(V_{CTRL} = V_{CC} - 1\text{ V}) D \rightarrow Q, \bar{Q}$	100 100	140 135	180 180	100 100	140 135	180 180	80 100	140 135	180 220	ps
t_{SKEW}	Duty Cycle Skew (Note 39)		3	20		3	15		3	10	ps
t_{JITTER}	RMS Random Clock Jitter $f_{in} < 10\text{ GHz}$ Peak-to-Peak Data Dependent Jitter $f_{in} < 10\text{ Gb/s}$		0.5 TBD	3		0.5 TBD	3		0.5 TBD	3	ps
V_{INPP}	Input Voltage Swing/Sensitivity (Differential Configuration) (Note 40)	75		2600	75		2600	75		2600	mV
t_r t_f	Output Rise/Fall Times (20% – 80%) @ 1 GHz $(V_{CTRL} = V_{CC} - 2\text{ V}) Q, \bar{Q}$ $(V_{CTRL} = V_{CC} - 1\text{ V}) Q, \bar{Q}$	25 22	50 45	70 60	25 22	50 45	70 60	25 22	50 45	70 60	ps

NOTE: Device will meet the specifications after thermal equilibrium has been established when mounted in a test socket or printed circuit board with maintained transverse airflow greater than 500 lfm. Electrical parameters are guaranteed only over the declared operating temperature range. Functional operation of the device exceeding these conditions is not implied. Device specification limit values are applied individually under normal operating conditions and not valid simultaneously.

38. Measured using a 500 mV source, 50% duty cycle clock source. All loading with $50\ \Omega$ to $V_{CC} - 2.0\text{ V}$. Input edge rates 40 ps (20% – 80%).

39. $t_{SKEW} = |t_{PLH} - t_{PHL}|$ for a nominal 50% differential clock input waveform. See Figure 10.

40. $V_{INPP(MAX)}$ cannot exceed $V_{CC} - V_{EE}$ (applicable only when $V_{CC} - V_{EE} < 2600\text{ mV}$).

41. Conditions include input amplitude of 500 mV and $V_{CTRL} = V_{CC} - 2\text{ V}$. Minimum output amplitude guarantee of 100 mV (see Output P-P Spec in Figure 9).

NBSG16VS

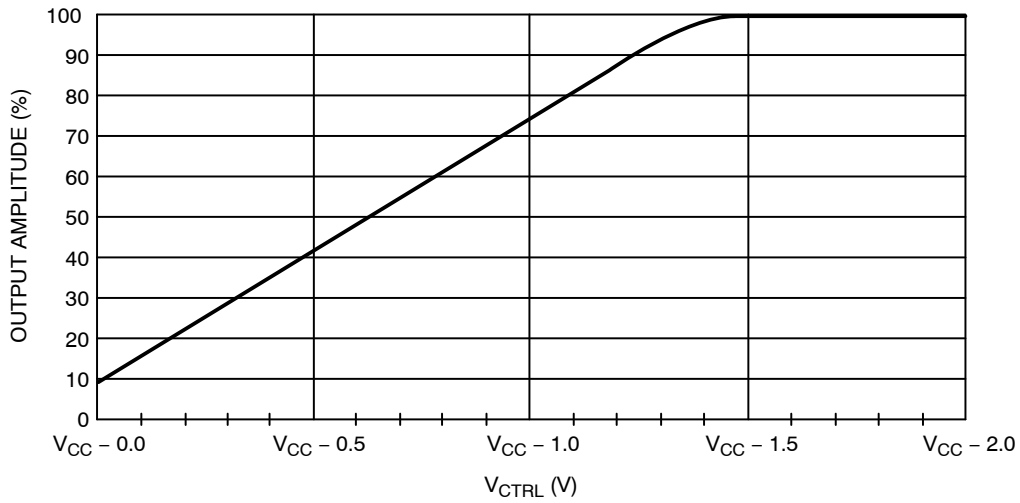

Figure 5. Output Amplitude % vs. V_{CTRL} (pin #A3)

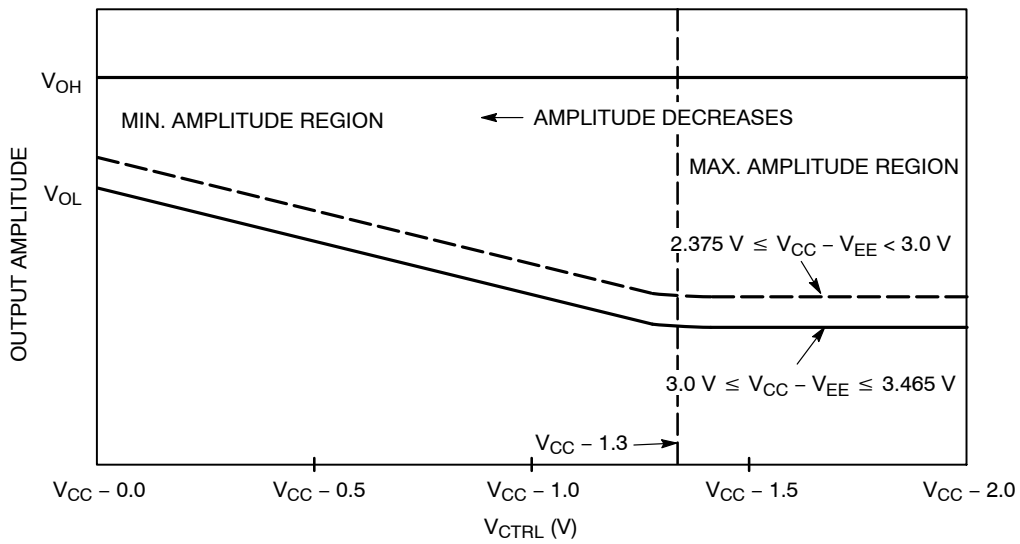

Figure 6. Output Amplitude vs. V_{CTRL} (pin #A3)

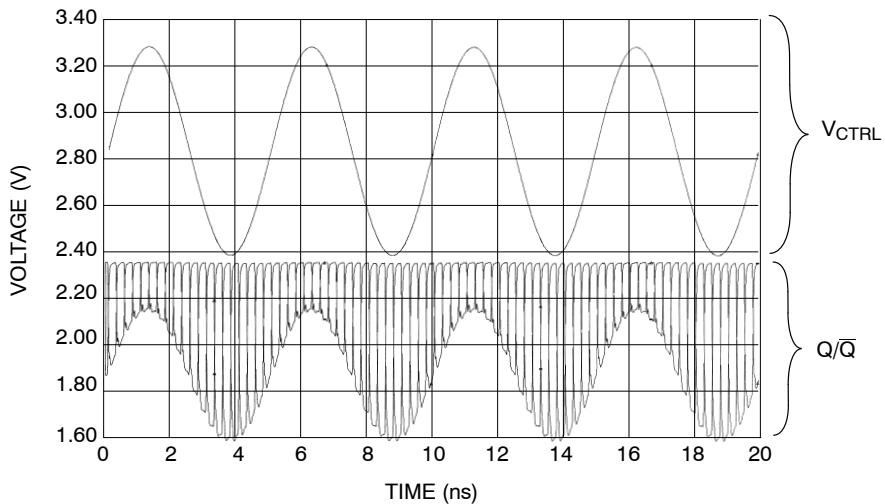

Figure 7. Output Response Under Amplitude Modulation of V_{CTRL}
 (Conditions Include $V_{CC} - V_{EE} = 3.3\text{ V}$ at 25°C , $f_{IN}(V_{CTRL}) = 200\text{ MHz}$, and $f_{IN}(D, \bar{D}) = 2\text{ GHz}$)

NBSG16VS

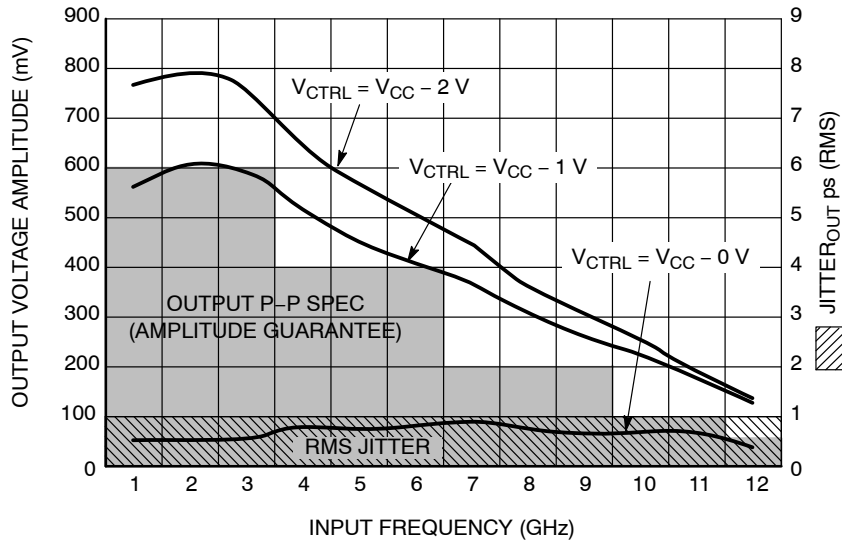

Figure 8. Output Voltage Amplitude (V_{OUTPP}) / RMS Jitter vs. Input Frequency (f_{in}) at Ambient Temperature (Typical) See Tables 8 and 10 ($V_{CC} = 0V$; $V_{EE} = -3.465V$ to $-3.0V$ or $V_{CC} = 3.0V$ to $3.465V$; $V_{EE} = 0V$)

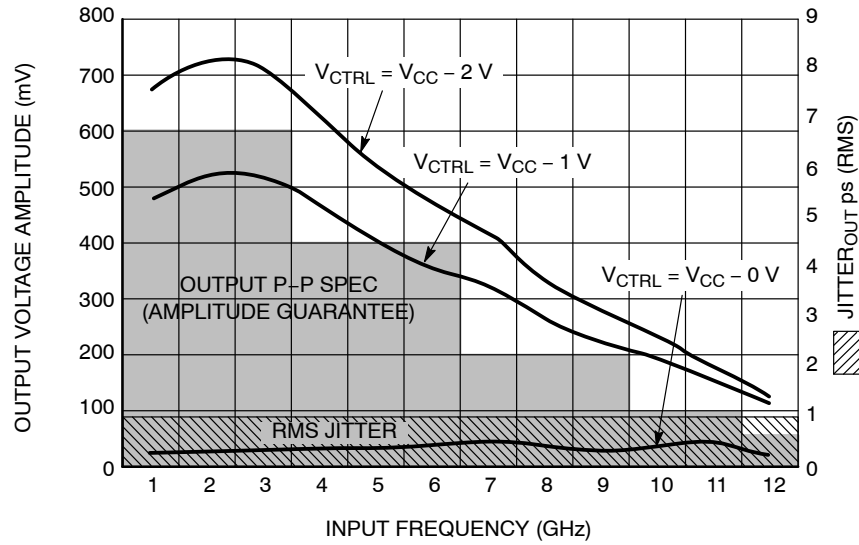

Figure 9. Output Voltage Amplitude (V_{OUTPP}) / RMS Jitter vs. Input Frequency (f_{in}) at Ambient Temperature (Typical) See Tables 9 and 11 ($V_{CC} = 0V$; $-3.0V$ $V_{EE} -2.375V$ or $2.375V$ $V_{CC} 3.0V$; $V_{EE} = 0V$)

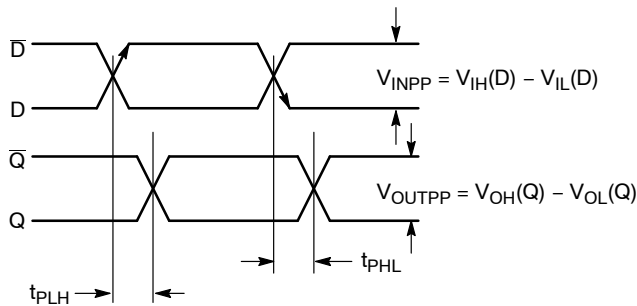
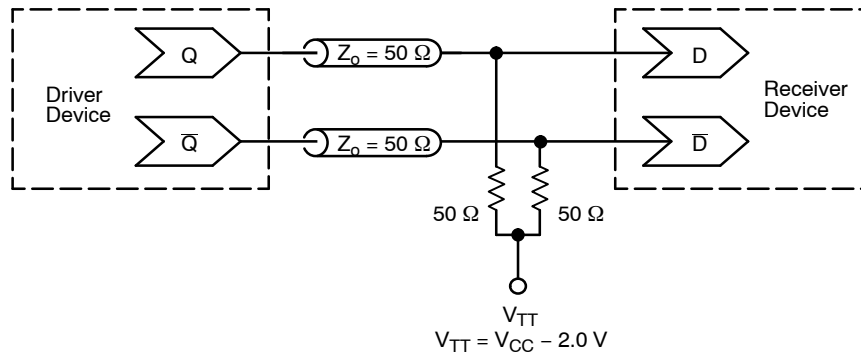

Figure 10. AC Reference Measurement

NBSG16VS



**Figure 11. Typical Termination for Output Driver and Device Evaluation
(See Application Note AND8020/D – Termination of ECL Logic Devices.)**

ORDERING INFORMATION

Device	Package	Shipping [†]
NBSG16VSBAHTBG	FCBGA-16 (Pb-Free)	100 / Tape & Reel
NBSG16VSBA	FCBGA-16	100 Units / Tray (Contact Sales Representative)
NBSG16VSBAR2	FCBGA-16	100 / Tape & Reel (Contact Sales Representative)
NBSG16VSMN	QFN-16	123 Units / Rail
NBSG16VSMNG	QFN-16 (Pb-Free)	123 Units / Rail
NBSG16VSMNR2	QFN-16	3000 / Tape & Reel
NBSG16VSMNR2G	QFN-16 (Pb-Free)	3000 / Tape & Reel
NBSG16VSMNHTBG	QFN-16 (Pb-Free)	100 / Tape & Reel

Board	Description
NBSG16VSBAEVB	NBSG16VSBA Evaluation Board

[†]For information on tape and reel specifications, including part orientation and tape sizes, please refer to our Tape and Reel Packaging Specifications Brochure, BRD8011/D.

NBSG16VS

PACKAGE DIMENSIONS

FCBGA-16
BA SUFFIX
 PLASTIC 4X4 (mm) BGA FLIP CHIP PACKAGE
 CASE 489-01
 ISSUE O

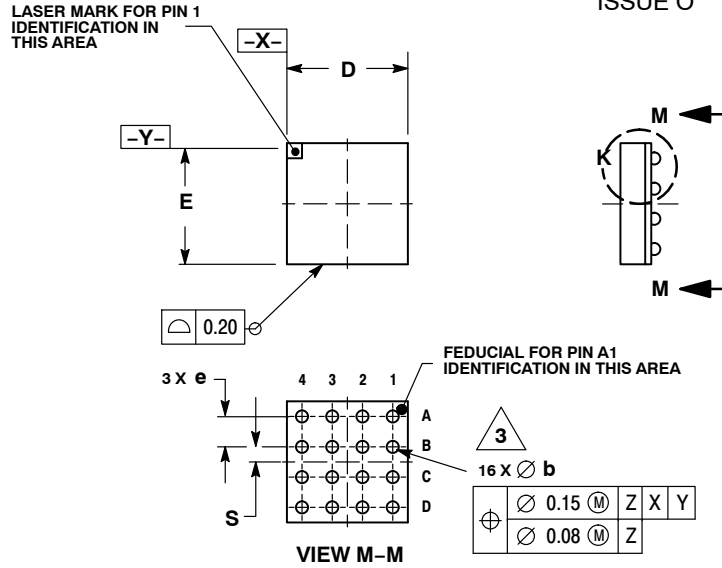

NOTES:

1. DIMENSIONS ARE IN MILLIMETERS.
2. INTERPRET DIMENSIONS AND TOLERANCES PER ASME Y14.5M, 1994.
3. DIMENSION b IS MEASURED AT THE MAXIMUM SOLDER BALL DIAMETER, PARALLEL TO DATUM PLANE Z.
4. DATUM Z (SEATING PLANE) IS DEFINED BY THE SPHERICAL CROWNS OF THE SOLDER BALLS.
5. PARALLELISM MEASUREMENT SHALL EXCLUDE ANY EFFECT OF MARK ON TOP SURFACE OF PACKAGE.

MILLIMETERS	
DIM	MIN MAX
A	1.40 MAX
A1	0.25 0.35
A2	1.20 REF
b	0.30 0.50
D	4.00 BSC
E	4.00 BSC
e	1.00 BSC
S	0.50 BSC

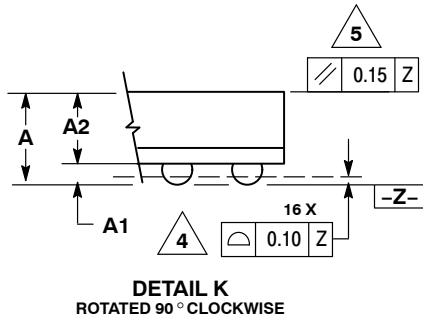

Looking for pricing, stock, or lifecycle information?

Click below to explore more details on WIN SOURCE:

- ⊖ [View NBSG16VSMN on WIN SOURCE](#)
- ⊖ [ON Semiconductor](#) Information

Optimize Your Supply Chain with WIN SOURCE Solutions

- ✓ Global Sourcing Solution
- ✓ Obsolete Management
- ✓ Cost Control Management
- ✓ Shortage Management
- ✓ Alternative Solution
- ✓ Excess Inventory Management