



**THE DATASHEET OF  
TPS23851DCE**



## Quad IEEE 802.3at Power-Over-Ethernet PSE Controller

Check for Samples: [TPS23851](#)

### FEATURES

- **INDUSTRY STANDARD PSE**
  - Fully IEEE Std 802.3at-2009 Compliant
  - Four Independent PSE Ports
    - PD Detection and Classification
    - Current Limit Output Protection with Foldback for Reduced Cost FET
    - AC and DC Disconnect Detection
  - I<sup>2</sup>C™ Communication
    - 4 Bit Address for 64-Port Systems
  - Flexible Operation Modes
    - Automatic
    - Semi Automatic
    - Processor Controlled
  - Pin Compatible with LTC4259A and MAX5952, MAX5945, MAX5935
- **ENHANCED FEATURES**
  - *Never Fooled* 4-Point Detection
  - Onboard Precision 110-Hz AC Disconnect Sine Wave Oscillator
  - I<sup>2</sup>C Watchdog for Failsafe Operation
  - Individual and Multiplexed Port Shutdown Modes
  - Per Port A/D Converters
    - 14-Bit Resolution for Precision Measurements
  - Real-time Voltage Monitoring
  - Real-time Current Monitoring
  - Inherent Filtering
  - Extended -20°C to 125°C Temperature Operation
  - 802.3at Type 2 Mode
    - High-Power Mode
  - Classification through Link Layer Discovery Protocol (LLDP)
  - Available in 36-lead SSOP Package

### DESCRIPTION

The TPS23851 is a quad-power controller engineered to insert power onto Ethernet cable according to IEEE Std 802.3at-2009 (or 802.3at) for Power Sourcing Equipment (PSE). The PSE controller can detect Powered devices (PDs) that have a valid signature, determine the power requirements of the devices according to the classification, and apply power to the devices, limited per 802.3at. Based on an industry standard register set, the PSE controller is software compatible with other PSE controllers for basic functionality.

Beyond the industry standard operation, the TPS23851 operates with enhanced features. Port current trip point can be set to all classification thresholds of IEEE Std 802.3-2005 (or 802.3af) and can be programmed up to more than 720 mA when used with a LLDP classification stack, complying with 802.3at. The TPS23851 supports AC and DC disconnection with a precision on-chip, 110-Hz oscillator for AC waveform generation. The PSE also contains four 14-bit A/D converters that constantly monitor voltage and current on each port. This information is available on the I<sup>2</sup>C bus for power management. The unique converter integrating topology used in the TPS23851 provides inherent filtering for a robust solution.

### Typical Application

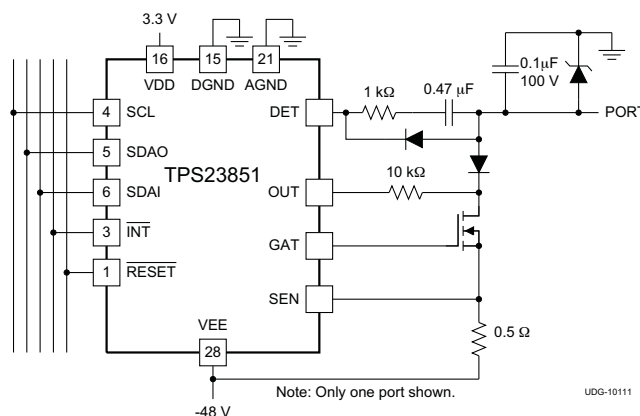

### APPLICATIONS

- Ethernet Switches and Routers



Please be aware that an important notice concerning availability, standard warranty, and use in critical applications of Texas Instruments semiconductor products and disclaimers thereto appears at the end of this data sheet.

I<sup>2</sup>C is a trademark of Royal Philips Electronics.



This integrated circuit can be damaged by ESD. Texas Instruments recommends that all integrated circuits be handled with appropriate precautions. Failure to observe proper handling and installation procedures can cause damage.

ESD damage can range from subtle performance degradation to complete device failure. Precision integrated circuits may be more susceptible to damage because very small parametric changes could cause the device not to meet its published specifications.

**PRODUCT INFORMATION<sup>(1)</sup>**

T <sub>J</sub>	PACKAGE	ORDERING CODE	MARKING
-20°C to 125°C	DCE36 (SSOP)	TPS23851DCE	TPS23851

(1) For the most current package and ordering information, see the Package Option Addendum at the end of this document, or visit the device product folder on [www.ti.com](http://www.ti.com).

**ABSOLUTE MAXIMUM RATINGS<sup>(1)</sup>**

voltages are referenced to DGND (unless otherwise noted)

PARAMETER		MIN	MAX	UNIT	
Input voltage	VEE to AGND	-70	0.3	V	
Input voltage	VDD	-0.3	3.6		
Voltage range	AGND	-1	1		
Voltage range	SDAI, SDAO <sup>(2)</sup> , SCL, A0 <sup>(3)</sup> , A1 <sup>(3)</sup> , A2 <sup>(3)</sup> , A3 <sup>(3)</sup> , SHDN1-4, RESET, INT <sup>(2)</sup>	-0.3	3.6		
Output voltage	GATE1-4 to VEE <sup>(4)</sup>	-0.3	12		
Input voltage range	SEN1-4 to VEE	-0.3	3		
Input voltage range	OUT1-4 to VEE	-3	70		
Voltage range	DET1-4 to VEE <sup>(2)</sup>	-0.3	70		
Voltage range	TSTA, TSTB <sup>(2)</sup>	VEE	VDD		
Voltage slew rate	VEE		1		V/μs
Sinking current,	INT, SDAO		20		mA
ESD – human body model					2
ESD – charged device model				500	V
Operating junction temperature range	T <sub>J</sub>	Internally limited			
Storage temperature	T <sub>ST</sub>	-65	125	°C	

- (1) Stresses beyond those listed under "absolute maximum ratings" may cause permanent damage to the device. These are stress ratings only and functional operation of the device at these or any other conditions beyond those indicated under "recommended operating conditions" is not implied. Exposure to absolute-maximum-rated conditions for extended periods may affect device reliability.
- (2) Do not apply external voltage sources directly.
- (3) A3-A0 can be directly tied to DGND but a resistor (at least 2 kΩ) must be used if pulled up. Do not tie directly to a positive voltage source.
- (4) Application of voltage is not implied – these are internally driven pins.

## THERMAL INFORMATION

THERMAL METRIC <sup>(1)</sup>		TPS23851		UNITS
		DCE		
		36 PINS		
$\theta_{JA}$	Junction-to-ambient thermal resistance <sup>(2)</sup>	52.4		°C/W
$\theta_{JCTop}$	Junction-to-case (top) thermal resistance <sup>(3)</sup>	25.1		
$\theta_{JB}$	Junction-to-board thermal resistance <sup>(4)</sup>	29.0		
$\psi_{JT}$	Junction-to-top characterization parameter <sup>(5)</sup>	3.4		
$\psi_{JB}$	Junction-to-board characterization parameter <sup>(6)</sup>	26.4		
$\theta_{JCbott}$	Junction-to-case (bottom) thermal resistance <sup>(7)</sup>	n/a		

- (1) For more information about traditional and new thermal metrics, see the *IC Package Thermal Metrics* application report, [SPRA953](#).
- (2) The junction-to-ambient thermal resistance under natural convection is obtained in a simulation on a JEDEC-standard, high-K board, as specified in JESD51-7, in an environment described in JESD51-2a.
- (3) The junction-to-case (top) thermal resistance is obtained by simulating a cold plate test on the package top. No specific JEDEC-standard test exists, but a close description can be found in the ANSI SEMI standard G30-88.
- (4) The junction-to-board thermal resistance is obtained by simulating in an environment with a ring cold plate fixture to control the PCB temperature, as described in JESD51-8.
- (5) The junction-to-top characterization parameter,  $\psi_{JT}$ , estimates the junction temperature of a device in a real system and is extracted from the simulation data for obtaining  $\theta_{JA}$ , using a procedure described in JESD51-2a (sections 6 and 7).
- (6) The junction-to-board characterization parameter,  $\psi_{JB}$ , estimates the junction temperature of a device in a real system and is extracted from the simulation data for obtaining  $\theta_{JA}$ , using a procedure described in JESD51-2a (sections 6 and 7).
- (7) The junction-to-case (bottom) thermal resistance is obtained by simulating a cold plate test on the exposed (power) pad. No specific JEDEC standard test exists, but a close description can be found in the ANSI SEMI standard G30-88.

## RECOMMENDED OPERATING CONDITIONS

voltages are referenced to DGND (unless otherwise noted)

PARAMETER		MIN	NOM	MAX	UNIT
$V_{VDD}$		3	3.3	3.5	V
$V_{VEE}$	To AGND	-44	-48	-57	
$V_{VEE}$	Slew rate			1	V/ $\mu$ s
$T_J$	Operating junction temperature	-20		125	°C
$T_A$	Operating free-air temperature	-20		85	

## ELECTRICAL CHARACTERISTICS

Conditions are  $-20 \leq T_J \leq 125^\circ\text{C}$  unless otherwise noted.  $V_{\text{VDD}} = 3.3\text{ V}$ ,  $V_{\text{VEE}} = -48\text{ V}$ ,  $V_{\text{DGND}} = V_{\text{AGND}}$ , and all outputs are unloaded, unless otherwise noted. Positive currents are into pins. Current sense resistor =  $0.5\ \Omega$ . Typical values are at  $25^\circ\text{C}$ . All voltages are with respect to DGND unless otherwise noted. Operating registers loaded with default values unless otherwise noted.

PARAMETER		TEST CONDITIONS	MIN	TYP	MAX	UNIT
<b>Input Supply</b>						
$I_{\text{VDD}}$	VDD current consumption			2	5	mA
$I_{\text{VEE}}$	VEE current consumption			-7	-10	
<b>Detection</b>						
$I_{\text{DISC}}$	Detection current	First detection point, DET = 0 V	145	165	190	$\mu\text{A}$
		Second detection point, DET = 0 V	245	275	310	
$V_{\text{DETECT}}$	Open circuit detection voltage		-25	-18.11	-17	V
$R_{\text{REJ\_LOW}}$	Rejected resistance low range		2.8		15	K $\Omega$
$R_{\text{REJ\_HI}}$	Rejected resistance high range		33		55	
$R_{\text{ACCEPT}}$	Accepted resistance range		19	25	26.5	
$R_{\text{SHORT}}$	Shorted port threshold				1.5	
$R_{\text{OPEN}}$	Open port threshold		55			
<b>Classification</b>						
$V_{\text{CLASS}}$	Classification voltage	At DET pin	-21	-18.5	-16.4	V
$I_{\text{CLASS\_Lim}}$	Classification current limit	At 0 V	52.5	70	95	mA
<b>Gate</b>						
$V_{\text{GOH}}$	Gate drive voltage	$V_{\text{GATE}n\text{-VEE}}$ , $I_{\text{GATE}} = -1\ \mu\text{A}$	8		10.5	V
$I_{\text{GO-}}$	Gate sinking current with port short-circuit detected	$V_{\text{GATE}n\text{-VEE}} = 5\text{ V}$	70	100	120	mA
$I_{\text{GO+}}$	Gate sourcing current	$V_{\text{GATE}n} = V_{\text{VEE}}$	0.05		1.5	
$t_{\text{D\_off}}$	Gate turn off time with /SHDNn	From $\overline{\text{SHDNn}}$ to $V_{\text{GATE}n\text{-VEE}} < 1\text{ V}$ , SENn connected to VEE			900	$\mu\text{s}$
$t_{\text{P\_off\_CMD}}$	Gate turn off time from port off command	From port off command to $V_{\text{GATE}n\text{-VEE}} < 1\text{ V}$ , SENn connected to VEE			900	
$t_{\text{P\_off\_RST}}$	Gate turn off time with RESET	From $\overline{\text{RESET}}$ low to $V_{\text{GATE}n\text{-VEE}} < 1\text{ V}$ , SENn connected to VEE	1		5	
$t_{\text{P\_didt}}$	Gate turn on and turn off di/dt control period	From port turn on/off command or from $\overline{\text{SHDN}}$ input		150		
<b>OUT Pin Sense</b>						
$V_{\text{PGT}}$	Power good threshold	Measured at $V_{\text{OUT}}$	1.5	2.13	3	V
	Resistance from OUT to AGND			2.5		M $\Omega$
$I_{\text{OUT}}$	OUT pin bias current	$V_{\text{OUT}} = 0\text{ V}$	-6		5	$\mu\text{A}$
		$-10\text{ V} > V_{\text{OUT}} > -30\text{ V}$	-18		0	
		$V_{\text{OUT}} = -48$	-30	-20	-10	

**ELECTRICAL CHARACTERISTICS (continued)**

Conditions are  $-20 \leq T_J \leq 125^\circ\text{C}$  unless otherwise noted.  $V_{VDD} = 3.3\text{ V}$ ,  $V_{VEE} = -48\text{ V}$ ,  $V_{DGND} = V_{AGND}$ , and all outputs are unloaded, unless otherwise noted. Positive currents are into pins. Current sense resistor =  $0.5\ \Omega$ . Typical values are at  $25^\circ\text{C}$ . All voltages are with respect to DGND unless otherwise noted. Operating registers loaded with default values unless otherwise noted.

PARAMETER		TEST CONDITIONS	MIN	TYP	MAX	UNIT
<b>AC Disconnect</b>						
$I_{ACD_{MAX}}$	Absolute magnitude of AC disconnect DET pin drive current	Port powered, $V_{VEE} < V_{DET} < V_{DGND}$ , relative to VEE	-5		15	mA
$I_{ACD_{MIN}}$	AC Disconnect DET pin drive current. Minimum current to remain connected.	Port powered	150	205	260	$\mu\text{A}$
$V_{ACD}$	Peak-to-peak DET pin output level	Port on, PD not present. Ports 1 – 4.	3.5	4	4.5	V
$f_{sin}$	sine wave frequency		100	110	125	Hz
<b>A/D Converter</b>						
$T_{CONV}$	Conversion time	All ranges, each port	15	20	27.5	ms
	Powered port voltage conversion scale factor and accuracy	OUT = -66 V	10800	11147	11400	Counts
		OUT = -44 V	7200	7432	7600	
	Powered port current conversion scale factor and accuracy	Port current = 770 mA	12288	12616	12944	
		Port current = 10 mA	100	163.8	220	
<b>Input Supply UVLO</b>						
$V_{UV_{EE\_F}}$	VEE UVLO falling threshold	VEUV threshold (supply event register) for port deassertion	25	31	34	V
$V_{UV_{P\_F}}$	VDD UVLO falling threshold	For port deassertion	1.9	2.3	2.6	
$V_{DD\_I2C}$	Required VDD supply for I <sup>2</sup> C operation		2.9			

## ELECTRICAL CHARACTERISTICS (continued)

Conditions are  $-20 \leq T_J \leq 125^\circ\text{C}$  unless otherwise noted.  $V_{DD} = 3.3\text{ V}$ ,  $V_{VEE} = -48\text{ V}$ ,  $V_{DGND} = V_{AGND}$ , and all outputs are unloaded, unless otherwise noted. Positive currents are into pins. Current sense resistor =  $0.5\ \Omega$ . Typical values are at  $25^\circ\text{C}$ . All voltages are with respect to DGND unless otherwise noted. Operating registers loaded with default values unless otherwise noted.

PARAMETER		TEST CONDITIONS	MIN	TYP	MAX	UNIT
<b>Port Current Sense</b>						
$V_{CUT}$	$I_{CUT}$ limit	OUT = VEE, ICUT(2:0) = 000b	175	187	200	mV
		OUT = VEE, ICUT(2:0) = 001b	45	55	65	
		OUT = VEE, ICUT(2:0) = 010b	90	102	115	
		OUT = VEE, ICUT(2:0) = 011b	175	187	200	
		OUT = VEE, ICUT(2:0) = 100b	350	377	400	
		OUT = VEE, ICUT(2:0) = 101b	276	296	316	
		OUT = VEE, ICUT(2:0) = 110b	318	343	365	
		OUT = VEE, ICUT(2:0) = 111b	385	408	430	
$V_{LIM}$	$I_{LIM}$ limit	OUT = - 47 V	200		225	mV
		OUT = - 30 V	200		225	
		OUT = - 10 V	90		175	
$V_{LIM2X}$	$I_{LIM}$ limit in 2X mode	OUT = - 47 V	409	431	452	mV
		OUT = - 40 V	409	431	452	
		OUT = - 10 V	150		300	
$V_{short}$	$I_{short}$ threshold	Threshold for GATE to be less than 1 V, 2 $\mu\text{s}$ after application of pulse	275	290	335	mV
$V_{short2X}$	$I_{short}$ threshold in 2X mode		525	562	625	
$I_{bias}$	Sense pin bias current		-100		100	$\mu\text{A}$
$I_{MIN}$	DC disconnect threshold		2.5		5	mV

**ELECTRICAL CHARACTERISTICS (continued)**

Conditions are  $-20 \leq T_J \leq 125^\circ\text{C}$  unless otherwise noted.  $V_{\text{VDD}} = 3.3\text{ V}$ ,  $V_{\text{VEE}} = -48\text{ V}$ ,  $V_{\text{DGND}} = V_{\text{AGND}}$ , and all outputs are unloaded, unless otherwise noted. Positive currents are into pins. Current sense resistor =  $0.5\ \Omega$ . Typical values are at  $25^\circ\text{C}$ . All voltages are with respect to DGND unless otherwise noted. Operating registers loaded with default values unless otherwise noted.

PARAMETER		TEST CONDITIONS	MIN	TYP	MAX	UNIT
<b>Timings</b>						
$t_{\text{ICUT}}$	$I_{\text{CUT}}$ time limit	TICUT = 00	50		70	ms
		TICUT = 01	25		35	
		TICUT = 10	100		140	
		TICUT = 11	200		280	
$t_{\text{START}}$	Maximum current limit duration in port start-up	TSTART = 00	50		70	
		TSTART = 01	25		35	
		TSTART = 10	100		140	
		TSTART = 11	200		280	
$t_{\text{DET}}$	Detection duration with 4-point discovery	Time to complete a detection	275		425	
$t_{\text{pdc}}$	Classification duration	Auto or semi-auto mode. From detection complete			50	
		Manual mode. From class command			50	
$T_{\text{pon}}$	Port power on delay	Auto mode from end of detection to port turn on			200	
		Manual mode from port turn on command to $I_{\text{GATE}} = I_{\text{GO+}}$			4	
$t_{\text{ed}}$	Error delay timing	Delay before next attempt to power a port following power removal due to error condition	750			
$T_{\text{RESET}}$	Reset time duration from RESET pin		3		6	$\mu\text{s}$
$T_{\text{RDG}}$	RESET input deglitch time		1		5	
$t_{\text{MPDO}}$	PD Maintain Power signature dropout time limit	TDIS = 00	300		400	ms
		TDIS = 01	75		100	
		TDIS = 10	150		200	
		TDIS = 11	600		800	
$t_{\text{SHDG}}$	SHDNn input deglitch time	SHDNx pin assertion threshold	1		5	$\mu\text{s}$
$t_{\text{POR}}$	device power-on reset delay				20	ms
<b>Digital Interface</b>						
$V_{\text{IH}}$	Digital input High		2.4			V
$V_{\text{IL}}$	Digital input Low				0.8	
$V_{\text{OL}}$	Digital output Low	at 3 mA			0.4	
		SDAO at 5 mA			0.7	
$R_{\text{pullup}}$	Pullup resistor to VDD	RESET, A[3:0], /SHDN[4:1]	30	50	80	k $\Omega$
$R_{\text{pulldown}}$	Pulldown resistor to DGND	AUTO pin	30	50	80	

## ELECTRICAL CHARACTERISTICS (continued)

Conditions are  $-20 \leq T_J \leq 125^\circ\text{C}$  unless otherwise noted.  $V_{\text{VDD}} = 3.3\text{ V}$ ,  $V_{\text{VEE}} = -48\text{ V}$ ,  $V_{\text{DGND}} = V_{\text{AGND}}$ , and all outputs are unloaded, unless otherwise noted. Positive currents are into pins. Current sense resistor =  $0.5\ \Omega$ . Typical values are at  $25^\circ\text{C}$ . All voltages are with respect to DGND unless otherwise noted. Operating registers loaded with default values unless otherwise noted.

PARAMETER		TEST CONDITIONS	MIN	TYP	MAX	UNIT
<b>I<sup>2</sup>C Interface Timing Requirements at <math>0 \leq T_J \leq 100^\circ\text{C}</math></b>						
$f_{\text{SCL}}$	SCL clock frequency				400	kHz
		$-20 \leq T_J \leq 100^\circ\text{C}$			100	
$t_{\text{LOW}}$	LOW period of the clock		1.3			$\mu\text{s}$
$t_{\text{HIGH}}$	HIGH period of the clock		0.6			
$t_{\text{fo}}$	SDAO output fall time	SDA, 2.3 V – 1.0 V, $C_b = 10\ \text{pF}$ , 10 k $\Omega$ pull-up to 3.3 V	21		250	ns
		SDA, 2.3 V – 1.0 V, $C_b = 400\ \text{pF}$ , 1.3 k $\Omega$ pull-up to 3.3 V	60		250	
$t_{\text{SU,DAT}}$	Data set-up time		200			
$t_{\text{HD,DAT}}$	Data hold time		150			
$t_{\text{rSDA}}$	Input rise/fall times of SDAI		20		120	
$t_{\text{r}}$	Input rise time of SCL		20		300	
$t_{\text{f}}$	Input fall time of SCL		20		150	
$t_{\text{BUF}}$	Bus free time between a STOP and START condition		1.3			
$t_{\text{HD,STA}}$	Hold time after (repeated) start condition		0.6			
$t_{\text{SU,STA}}$	Repeated start condition set-up time		0.6			
$t_{\text{SU,STO}}$	Stop condition set-up time		0.6			
$t_{\text{FLT\_INT}}$	Fault to $\overline{\text{INT}}$ assertion	Time to internally register an Interrupt fault		100		
$t_{\text{STOP\_INT}}$	STOP to $\overline{\text{INT}}$ assertion			140		
$t_{\text{ARA\_INT}}$	ARA to $\overline{\text{INT}}$ de-assertion				500	
<b>Thermal Shutdown</b>						
	Shutdown temperature	Temperature rising	143	154	161	$^\circ\text{C}$
	Hysteresis			8		

## DEVICE INFORMATION

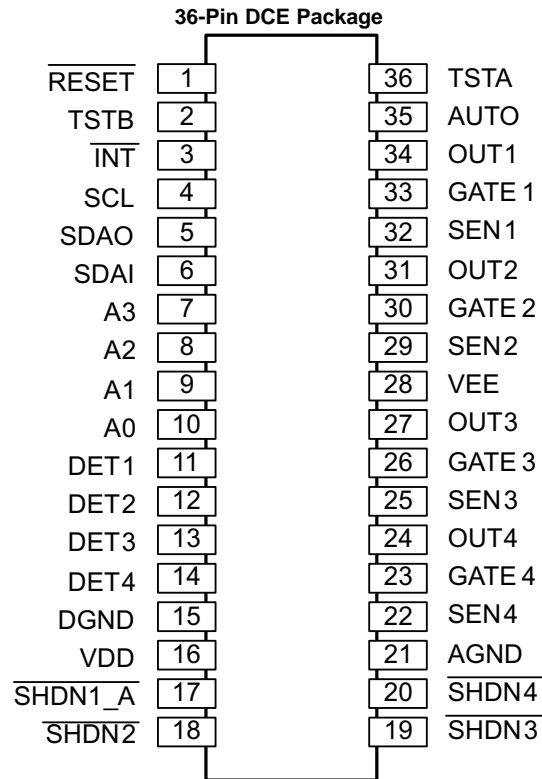

## PIN FUNCTIONS

PIN	NAME	I/O	DESCRIPTION
1	$\overline{\text{RESET}}$	I	Reset input. When asserted low, the TPS23851 will reset. This pin is internally pulled up to VDD.
2	TSTB		Used for internal test modes only. Negative high voltage may appear if test mode is enabled. Leave this pin open.
36	TSTA		Used for internal test modes only. Negative high voltage may appear if test mode is enabled. Leave this pin open
3	$\overline{\text{INT}}$	O	Interrupt output. This pin asserts low when a bit in the interrupt register is asserted. This pin is updated between I <sup>2</sup> C transactions. This output is open-drain.
4	SCL	I	Serial clock input for I <sup>2</sup> C bus.
5	SDAO	O	Serial data output for I <sup>2</sup> C bus. This pin can be connected to SDAI for non-isolated systems. This output is open-drain.
6	SDAI	I	Serial data input for I <sup>2</sup> C bus. This pin can be connected to SDAO for non-isolated systems.
7	A3	I	I <sup>2</sup> C A3-A0 Address lines. These pins are internally pulled up to VDD. Do not tie directly to a positive voltage source. <sup>(1)(2)</sup>
8	A2	I	
9	A1	I	
10	A0	I	
11, 12, 13, 14	DET1-4	I	Port 1-4 detect sense.
15	DGND		Digital ground.
16	VDD		Digital supply. Bypass VDD to DGND using 0.1 $\mu$ F and 1 $\mu$ F capacitors in parallel. Connect VDD to the 3.3V digital supply using a 10 $\Omega$ resistor.
17	$\overline{\text{SHDN1\_A}}$	I	Port 1 manual shutdown input or Port 1-4 multiplexed shutdown. This pin is internally pulled up to VDD.
18,19,20	$\overline{\text{SHDN2-4}}$	I	Port 2-4 manual shutdown logic input. These pins are internally pulled up to VDD.
21	AGND		Analog ground.
32, 29, 25	SEN1-3	I	Port 1-3 current sense input. Connect to current sense resistor.
22	SEN4	I	Port 4 current sense input. Connect to current sense resistor.
33, 30, 26, 23	GAT1-4	O	Port 1-4 gate drive output.
34, 31, 27, 24	OUT1-4	I	Port 1-4 output voltage monitor. Connect to output port through a 10-k $\Omega$ resistor.
28	VEE		Analog supply. Bypass VEE to AGND using 0.1 $\mu$ F and 1 $\mu$ F capacitors in parallel.
35	AUTO	I	Mode select input. Asserting high on power-up puts the TPS23851 into auto mode. This pin is internally pulled down to DGND.

(1) Can be directly tied to DGND but a resistor (at least 2 k $\Omega$ ) must be used if pulled up.

(2) A6, A5, A4 are factory set to 010.

## Detailed Pin Description

The following descriptions refer to the pinout and the functional block diagram.

**RESET:** Reset input, active low. When asserted, the TPS23851 will reset, turning off all ports and forcing the registers to their power-up state. This pin is internally pulled up to VDD, with internal 1- $\mu$ s to 5- $\mu$ s deglitch filter. External RC network can be used to delay the turn on. There is also an internal power-on reset which is independent of the **RESET** input.

**INT:** Interrupt output. This pin asserts low when a bit in the interrupt register is asserted. This pin is updated between I<sup>2</sup>C transactions. This output is open-drain. Interrupt functional diagram is shown in [Figure 31](#).

**SDAO:** Open-drain I<sup>2</sup>C bus output data line requiring an external resistive pullup. The TPS23851 uses separate SDAO and SDAI lines to allow optoisolated I<sup>2</sup>C interface. SDAO can be connected to SDAI for non-isolated systems.

**SCL:** Serial clock input for I<sup>2</sup>C bus.

**SDAI:** Serial data input for I<sup>2</sup>C bus. This pin can be connected to SDAO for non-isolated systems. Note that the data sent by the TPS23851 on SDAO must be mirrored on its SDAI line for correct operation. See [Figure 35](#).

**A3-A0:** I<sup>2</sup>C bus address inputs. Can be directly tied to DGND but a resistor (at least 2 k $\Omega$ ) must be used if pulled up. These pins are internally pulled up to VDD. See the Pin Status Register for more details.

**SHDN1\_A:** Port 1 Manual Shutdown Input or Port 1-4 Multiplexed Shutdown, active low. This pin is internally pulled up to VDD, with internal 1- $\mu$ s to 5- $\mu$ s deglitch filter.

When Multiplexed Shutdown is disabled, pulling low **SHDN1\_A** turns off port 1, regardless of the state of registers except the Multiplexed Shutdown Configuration Register.

When Multiplexed Shutdown is Enabled, pulling low **SHDN1\_A** turns off the ports selected in the Multiplexed Shutdown Configuration Register. This turn off action is triggered regardless of the state of registers except the Multiplexed Shutdown Configuration Register.

**SHDN2-4:** Port 2-4 Manual Shutdown Logic Input, active low. These pins are internally pulled up to VDD, with internal 1- $\mu$ s to 5- $\mu$ s deglitch filter. When Multiplexed Shutdown is disabled, pulling low **SHDNn** turns off port n, regardless of the state of registers except the Multiplexed Shutdown Configuration Register.

---

### NOTE

If the Multiplexed Shutdown function is Enabled, the **SHDN2** to **SHDN4** inputs must be at logic High.

---

**DET1-DET4:** Port 1-4 detect sense.

Used during AC disconnect detection and powered device discovery. Connect to output port through a 1 k $\Omega$  in series with a 0.47  $\mu$ F, both in parallel with a diode. AC disconnect consists in sensing the load impedance by injecting an AC voltage at DETn pin and measuring the resultant current through the same pin. If the impedance is higher than a defined threshold, the port will automatically be turned off. The DET pin sine wave output voltage typically has a 2.5-V offset above the VEE supply, with a 2 V peak-to-peak amplitude under a no load condition.

The TPS23851 uses an innovative 4-point technique in order to provide a reliable PD detection. The discovery is performed by sinking two different current levels via the DETn pin, while the PD voltage is measured from DGND to DET. The 4-point measurement provides the capability to avoid powering a capacitive or legacy load.

The resistor and capacitor are not needed if AC disconnect is not used. If the port is not used, the DETn pin can be floated or tied to VEE.

**GAT1-GAT4:** Port 1-4 gate drive output used for external N channel MOSFET gate control. At port turn on, it is driven positive by a low current charge pump to turn the MOSFET on. Note that the MOSFET turn on is done with di/dt control, which means that an internal amplifier forces the load current to track an internally defined voltage ramp. GATn is pulled low whenever any of the input supplies are low or if an over-current timeout has occurred. GATn will also be pulled low if its port is turned off by use of manual shutdown inputs. Leave floating if unused.

For a robust design, a current foldback function limits the power dissipation of the MOSFET during low resistance load or a short circuit event. The foldback mechanism measures the port voltage across AGND and OUTn to reduce the current limit threshold from 100% at 18 V (28 V if in 2X mode) down to around 14% at a port voltage of 0 V.

When  $I_{CUT}$  threshold is exceeded while a port is on, a timer starts. During that time, linear current limiting makes sure the current will not exceed  $I_{LIM}$  combined with current foldback action. When the timer reaches its  $t_{CUT}$  (or  $t_{START}$  if at port turn on) limit, the port shuts off. When the port current goes below  $I_{CUT}$ , while there is no foldback action, the counter counts down at a rate  $1/16^{th}$  of the increment rate and it must reach a count of zero before the port can be turned on again.

The fast overload protection is for major faults like a direct short. This turns off the MOSFET in less than a microsecond, for a period of 100  $\mu$ s, after which the gate is slowly turned back on with controlled di/dt. If the port is not used, tie SENn to VEE.

**OUT1-OUT4:** Port 1-4 output voltage monitor. Used to measure the port output voltage, for port voltage monitoring, port power good detection and foldback action. Should be connected to output port through a 10-k $\Omega$  resistor. There is an internal resistor between each OUTn pin and AGND. If the port n is not used, OUTn can be left floating or tied to AGND.

**SEN1-4:** Port 1-4 current sense input, relative to VEE. Monitors the external MOSFET current by use of a 0.5- $\Omega$  current sense resistor connected to VEE. Used by current foldback engine and also during classification. Can be used to perform load current monitoring via A/D conversion.

A classification is done while using the external MOSFET so that doing a classification on more than one port at same time is possible without overdissipation in the TPS23851.

For the DC disconnect function, there is an internal 2- $\mu$ s analog filter on the SEN1-4 pins to provide glitch filtering.

SENn is a single ended measurement for all four ports and any voltage drop on the VEE path between the sense resistor and the VEE pin of TPS23851 can introduce errors, particularly during classification. Consequently, the PCB layout must be done in order to mitigate any such error, for example by using a copper plane, a star return point at the VEE pin for all four current sense resistors, or both. Connect to VEE if the port is unused.

---

#### NOTE

In order to meet clearance safety regulations, a fuse or an equivalent component should be inserted in series between the SEN4 pin and its corresponding current sense resistor.

---

**AUTO:** Auto mode input. A logic high state at POR means the TPS23851 will operate autonomously in auto mode even in the absence of a host controller. The state of that pin is measured only immediately following a Power-on-Reset or after the RESET input has been activated.

TYPICAL CHARACTERISTICS

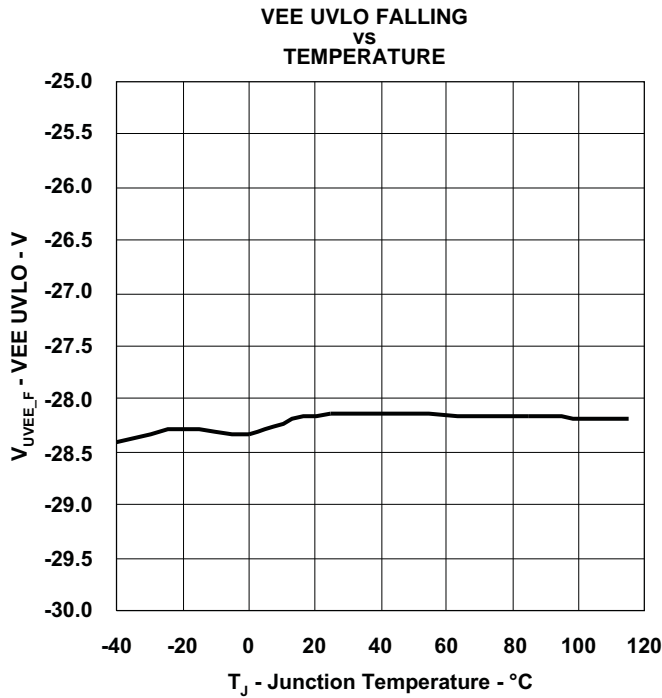

Figure 1.

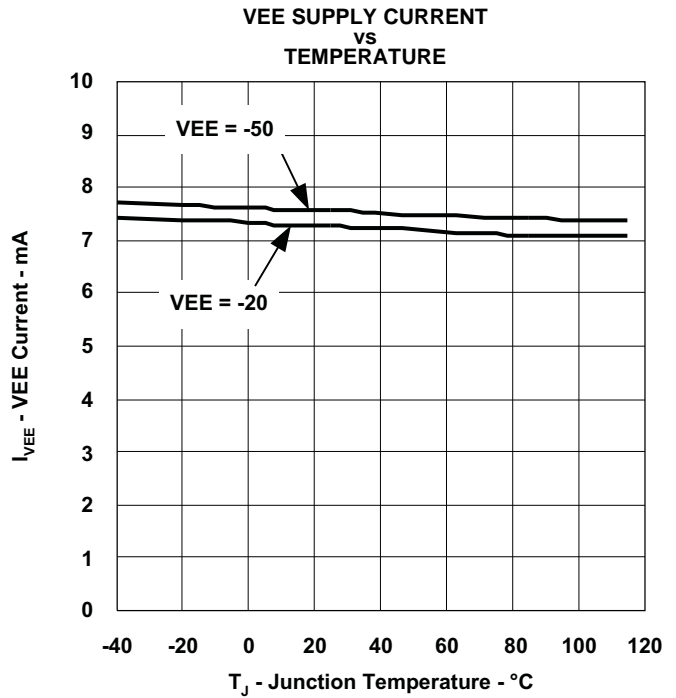

Figure 2.

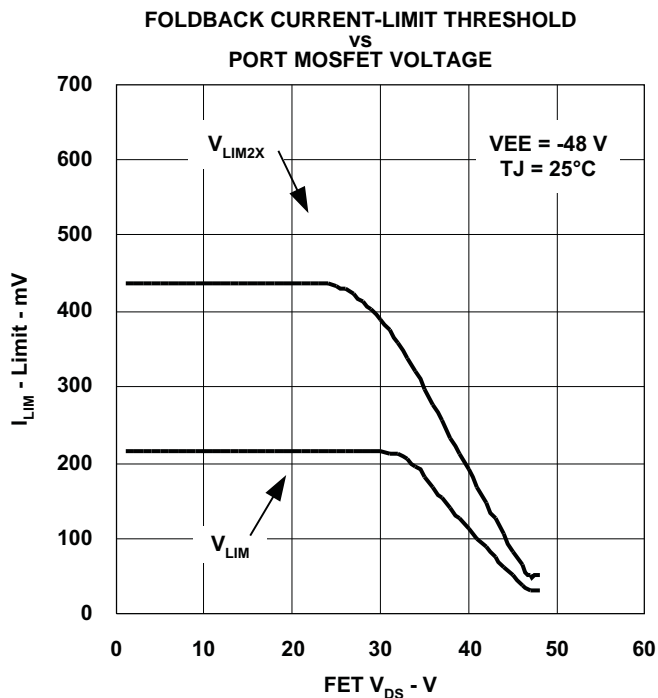

Figure 3.

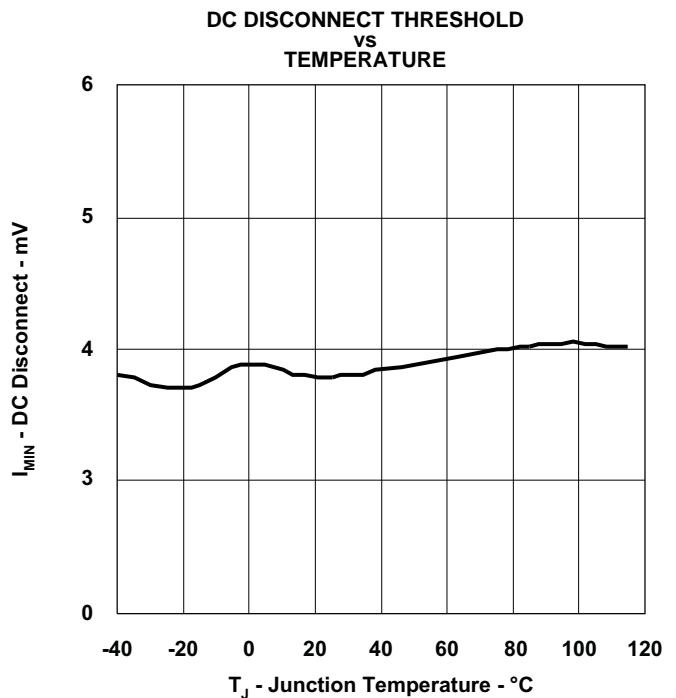

Figure 4.

**TYPICAL CHARACTERISTICS (continued)**

**VDD SUPPLY CURRENT  
VS  
VDD**

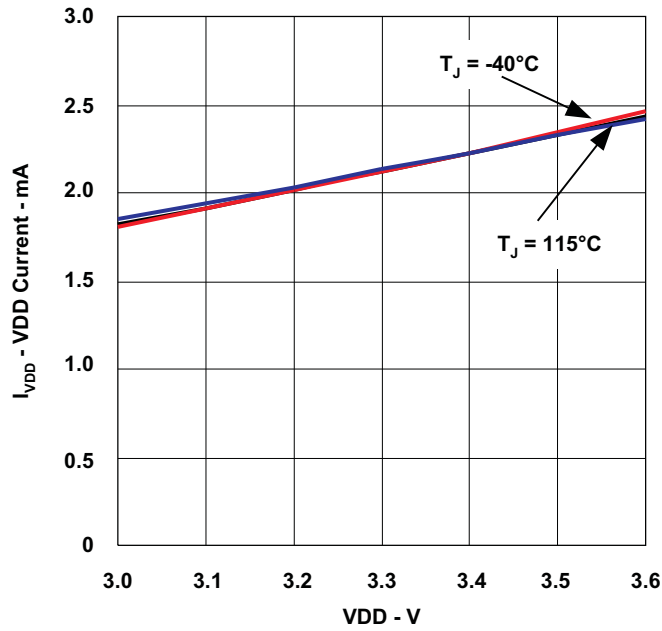

Figure 5.

**SENSE TRIP VOLTAGE  
VS  
TEMPERATURE**

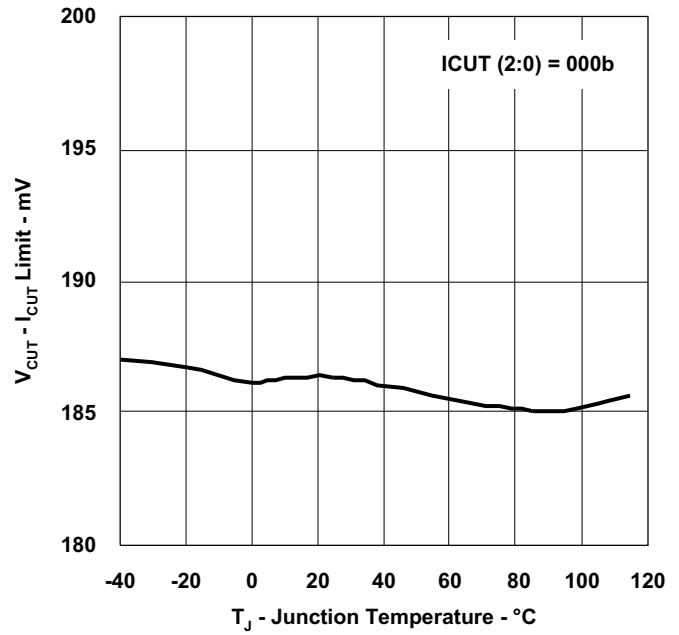

Figure 6.

TYPICAL CHARACTERISTICS (continued)

STARTUP WITH VALID PD (25 KΩ and 0.1 μF), CLASS 0

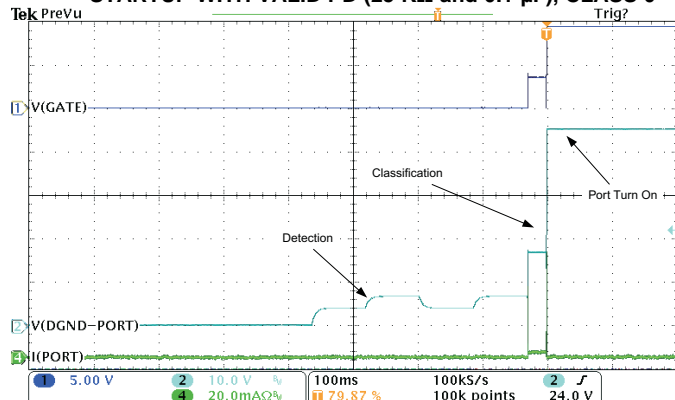

Figure 7.

STARTUP WITH VALID PD (25 KΩ and 0.1 μF), CLASS 1

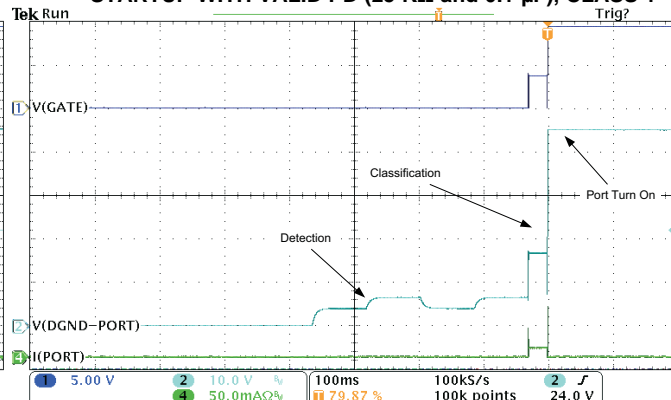

Figure 8.

STARTUP WITH VALID PD (25 KΩ and 0.1 μF), CLASS 2

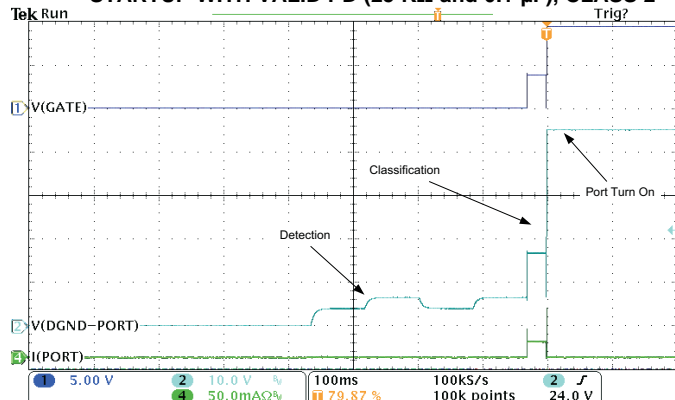

Figure 9.

STARTUP WITH VALID PD (25 KΩ and 0.1 μF), CLASS 3

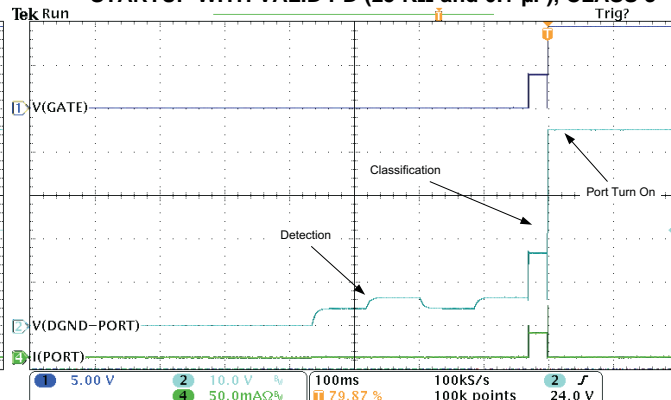

Figure 10.

STARTUP WITH VALID PD (25 KΩ and 0.1 μF), CLASS 4

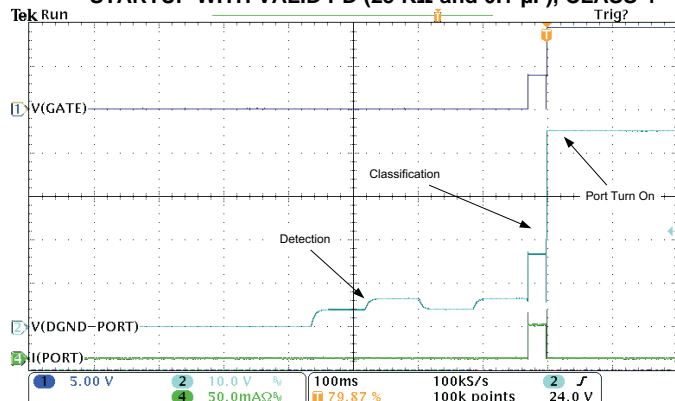

Figure 11.

DETECTION WITH INVALID PD (25 KΩ and 10 μF)

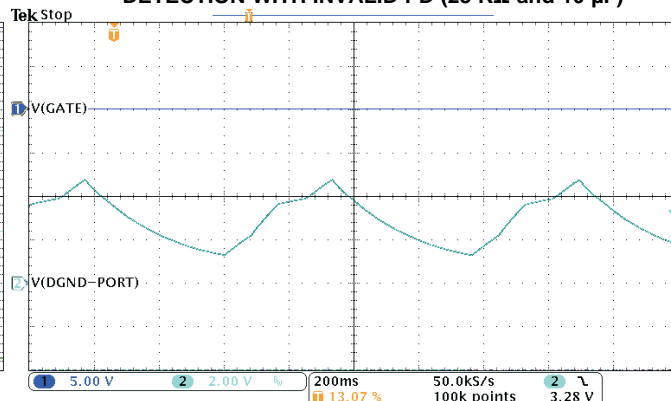

Figure 12.

**TYPICAL CHARACTERISTICS (continued)**

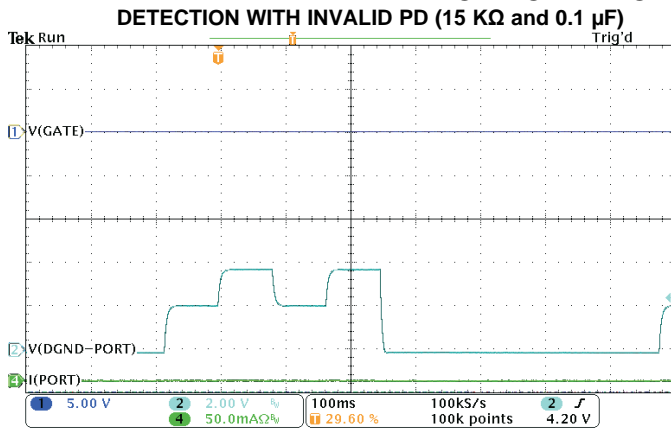

Figure 13.

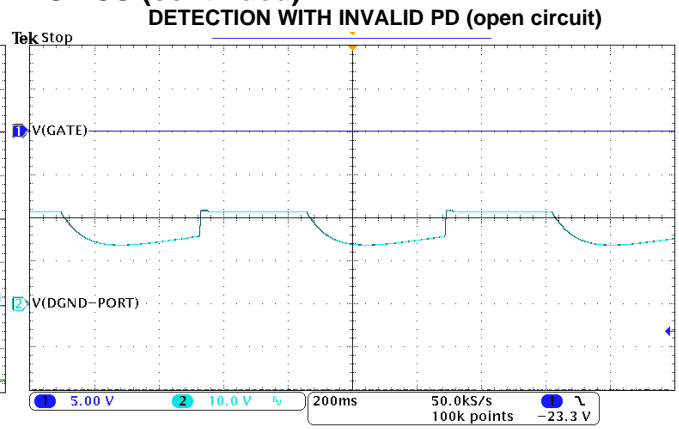

Figure 14.

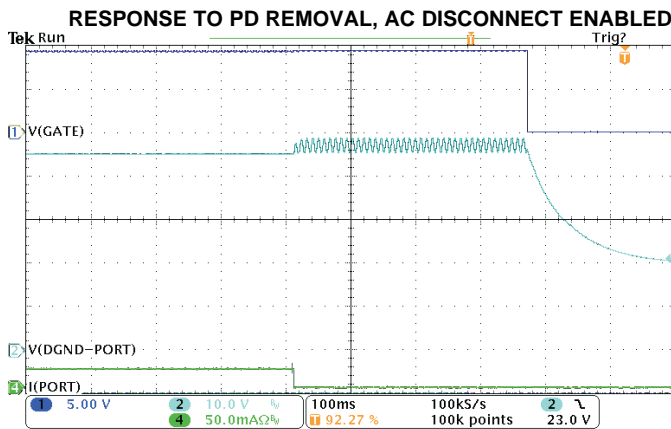

Figure 15.

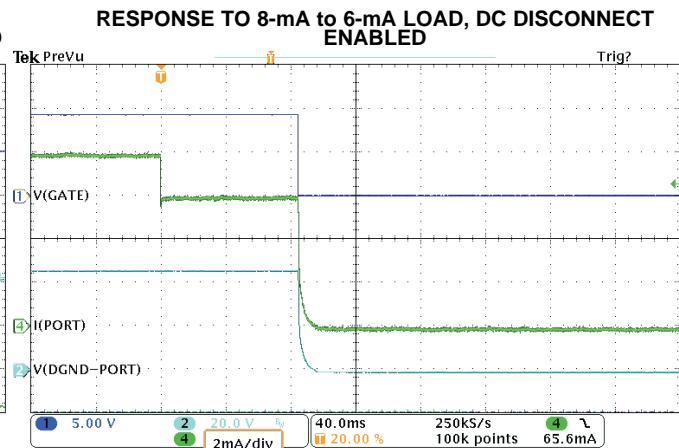

Figure 16.

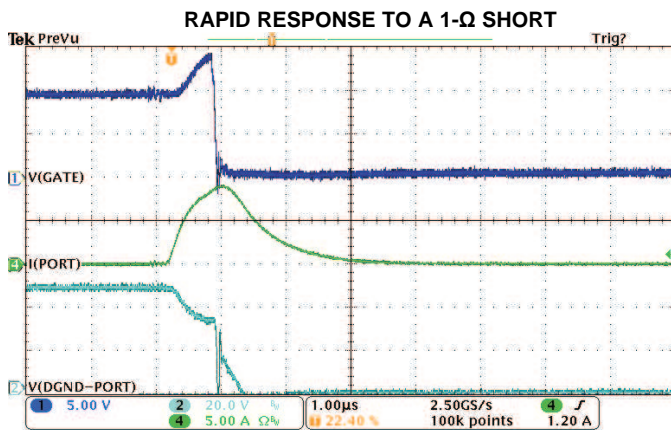

Figure 17.

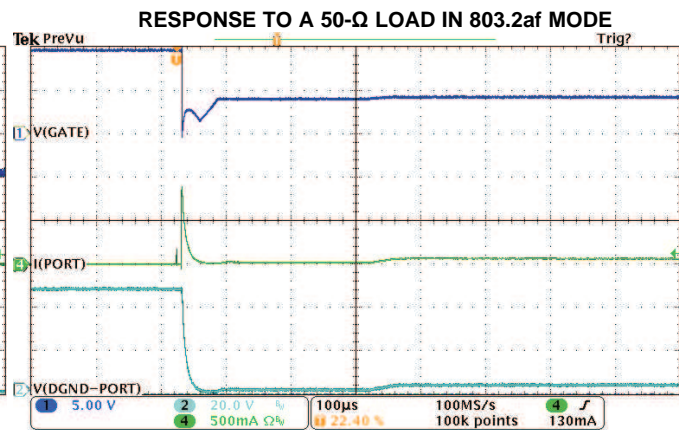

Figure 18.

TYPICAL CHARACTERISTICS (continued)

RESPONSE TO A 39-Ω LOAD IN HIGH-POWER MODE

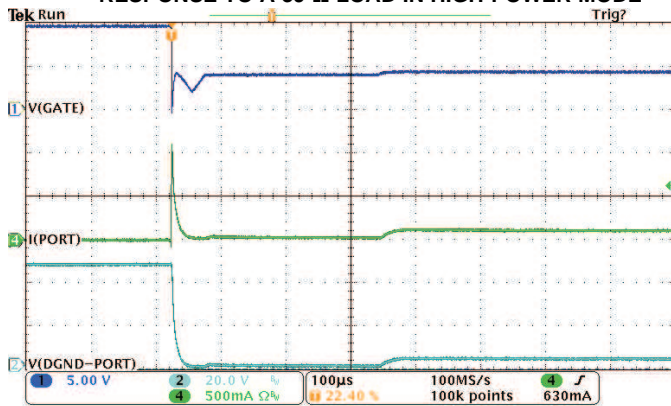

Figure 19.

OVERCURRENT RESTART DELAY

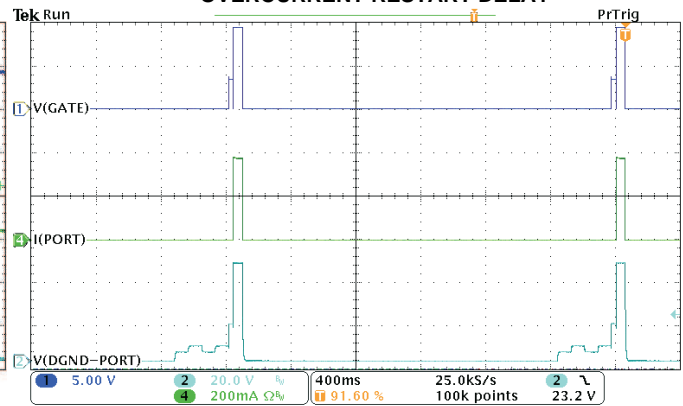

Figure 20.

Figure 21. OVERCURRENT RESTART DELAY WITH CURRENT LIMIT

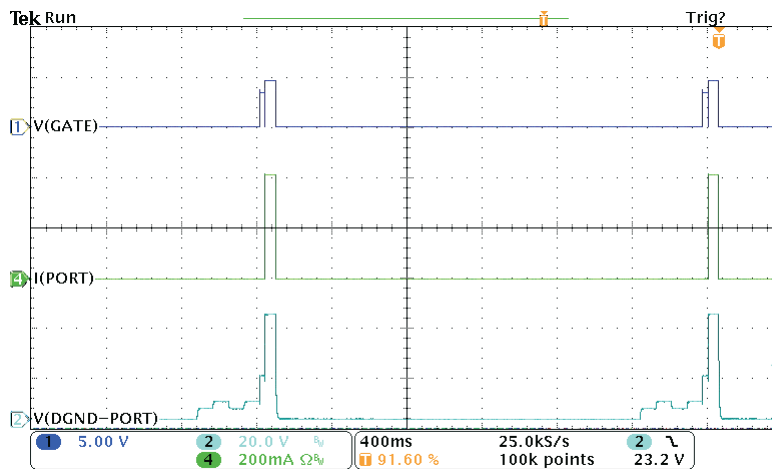
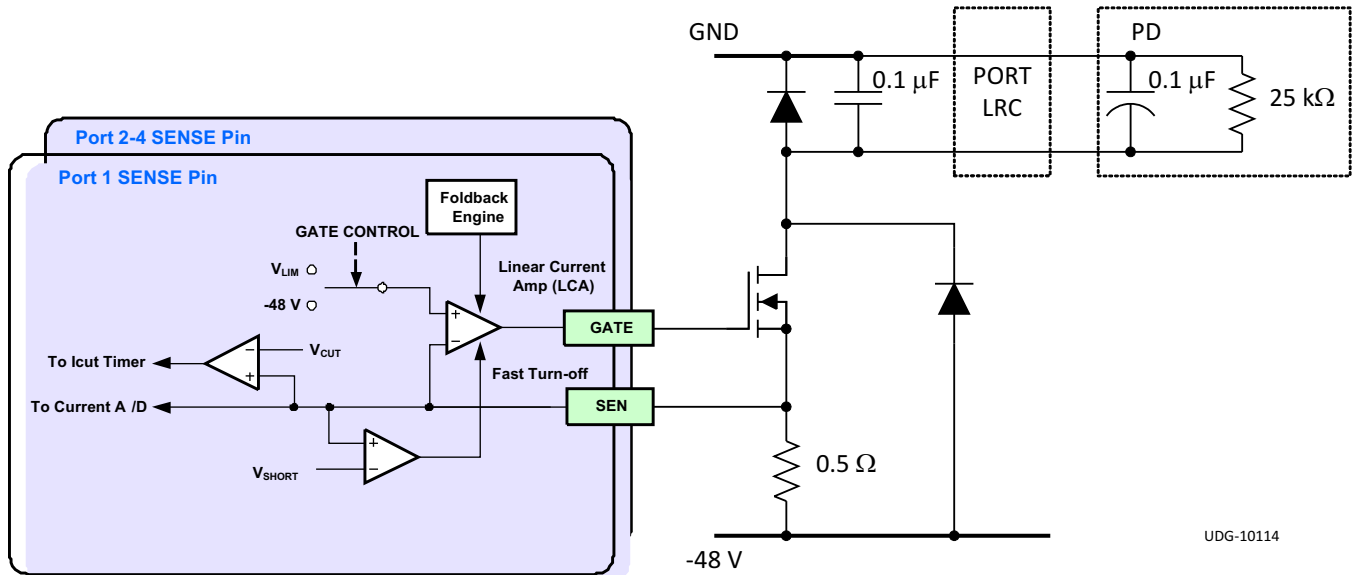

Figure 22.

TYPICAL CHARACTERISTICS (continued)

Block Diagrams



UDG-10114

Figure 23. Port Current Sense Circuitry

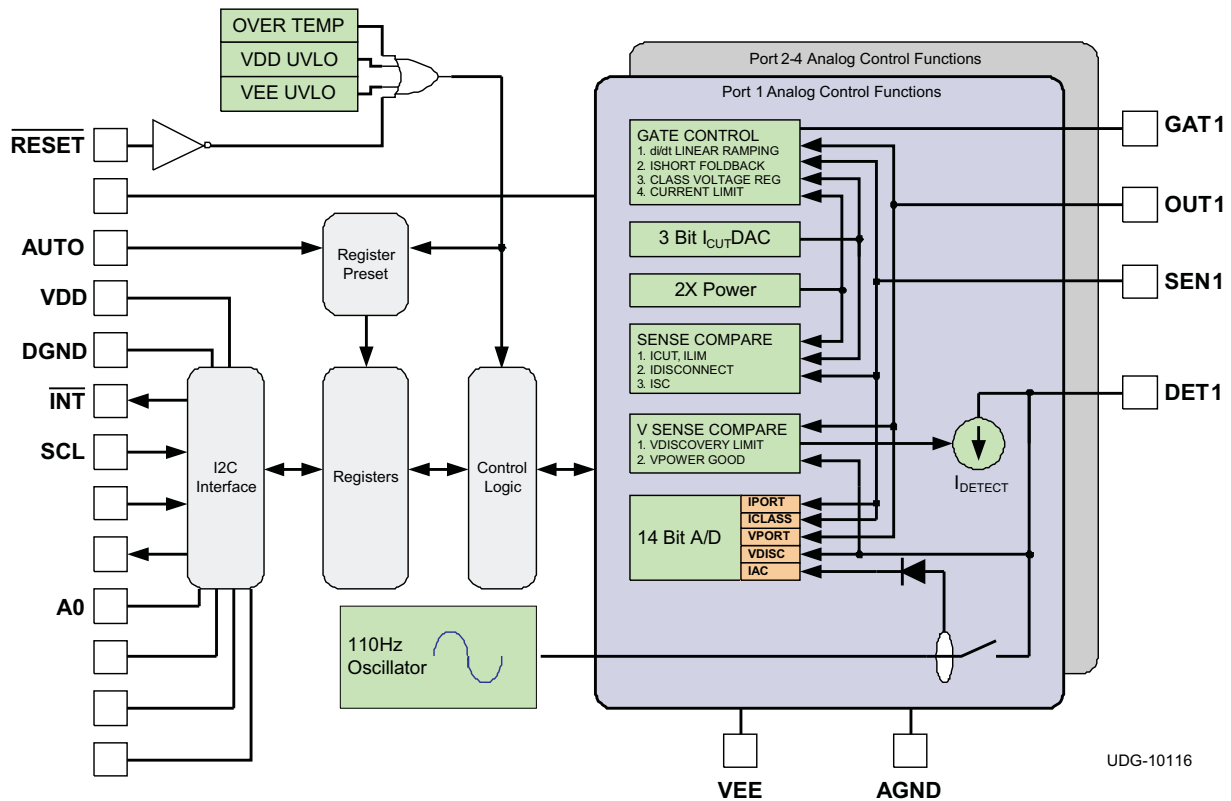

UDG-10116

Figure 24. Block Diagram

TYPICAL CHARACTERISTICS (continued)

Timing Diagrams

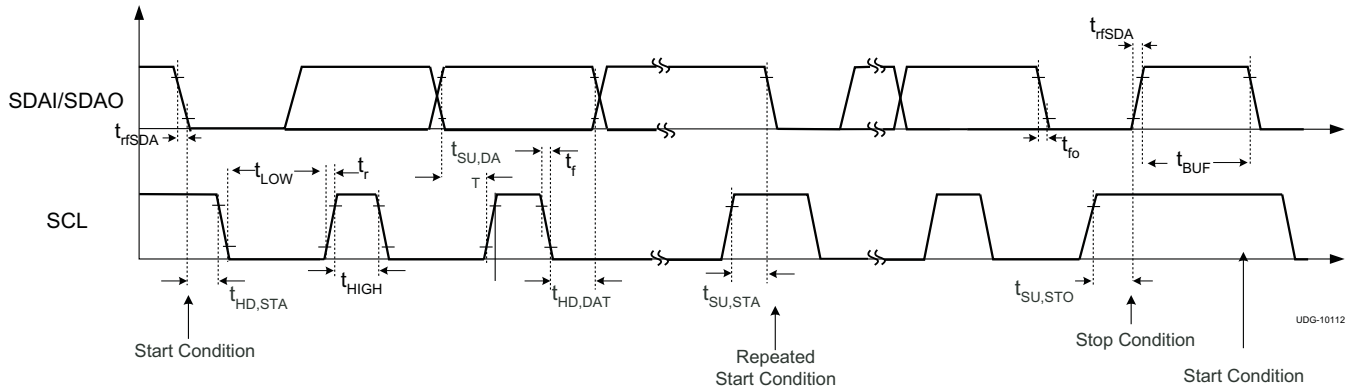

Figure 25. I<sup>2</sup>C Timings

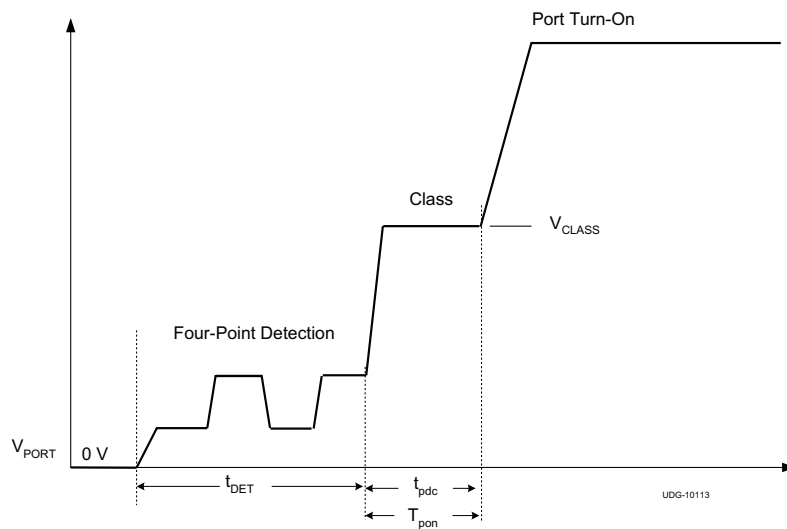

Figure 26. Detection, Classification and Turn On In Auto Mode

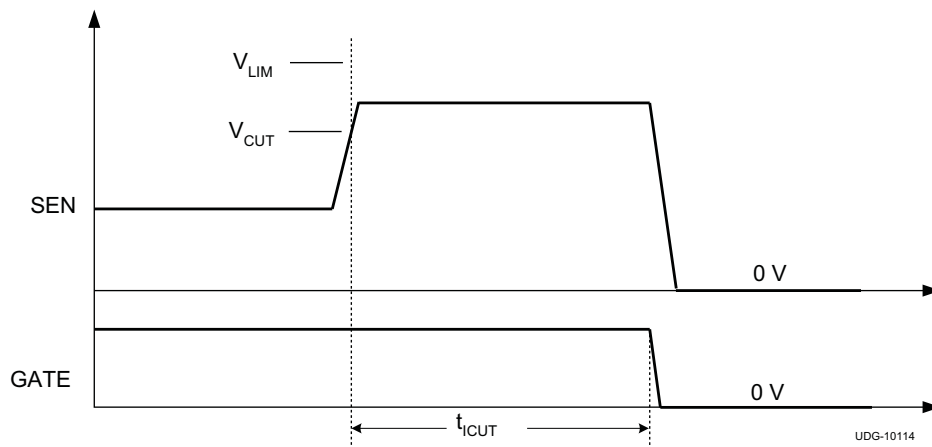

Figure 27. Overcurrent Fault Timing

## DETAILED DESCRIPTION

### A/D Converters

The TPS23851 features one 14-bit multi-slope integrating converter per port, for a total of four converters. Each converter is operated independently to perform measurements in any of the following modes: discovery, classification, port powered (current, voltage and AC disconnect).

The A/D converter type used in the TPS23851 differs from other similar types of converters in that it converts while the input signal is being sampled by the integrator, resulting in reduced conversion time and providing inherent filtering over the conversion period. The typical conversion time of this converter is 20 ms with 17.5-ms sampling window, providing significant rejection of noise at 50-Hz to 60-Hz line frequency.

---

#### NOTE

1. During AC disconnect measurement, the converter integration is synchronized with the sine wave generator for rejection of the excitation signal.
  2. Note that during port powered mode, voltage conversions are interleaved with port current conversions. If AC disconnect is Enabled, DC current, DC voltage and AC current measurements are interleaved.
- 

When a port is on, its voltage and current results are stored in the Port n Voltage and Port n Current Registers.

---

#### NOTE

The content of the Port #n Current and Voltage Registers is not updated when the port is off.

---

Any port reading should be qualified with the PGn bit of the Power Status Register (10h). If the port bit is a 1, then the reading should be accepted. If zero, the A/D reading should be considered corrupt as it may represent a port that experienced a power fault event or was disabled midway through a conversion.

Also, in port powered mode, the  $t_{\text{START}}$  timer must expire before any current or voltage A/D conversion can begin. Each 14-bit result can be read via a 2-byte read cycle, as shown in Figure 5.

## I<sup>2</sup>C Serial Interface

The TPS23851 features a 3-wire I<sup>2</sup>C interface, using SDAI, SDAO and SCL. Each transmission includes a Start condition sent by the master, followed by the device address (7-bit) with R/W bit, a register address byte, then one or two data bytes, and a Stop condition. There is also an acknowledge bit sent by the recipient following each byte transmitted. Also, SDAI/SDAO is stable while SCL is high except during a Start or Stop condition. Figure 28 illustrates read and write operations through I<sup>2</sup>C interface. The 2 data bytes read operation is applicable to A/D conversion results. Note that the data sent by the TPS23851 on SDAO must be mirrored on its SDAI line for correct operation, as shown.

The TPS23851 features a quick access to the Interrupt Register through I<sup>2</sup>C bus. See Figure 28.

### NOTE

This means that when a Stop Bit is received, the register pointer is automatically reset. This means that there must not be any Stop Bit before a Repeated Start Bit, as shown.

It is also possible to perform a write operation to many TPS23851 devices at same time. The slave address during this broadcast access is 0x30, as shown in the Pin Status Register description.

The TPS23851, using the  $\overline{\text{INT}}$  line, supports the SMBALERT protocol.

When  $\overline{\text{INT}}$  is asserted low, if the bus master controller sends the Alert response address, the TPS23851 responds providing its device address on the SDA line and releases the  $\overline{\text{INT}}$  line. If there is a collision between two TPS23851 devices responding simultaneously, then the device with the lower address wins arbitration and responds first, by use of SDAI and SDAO lines.

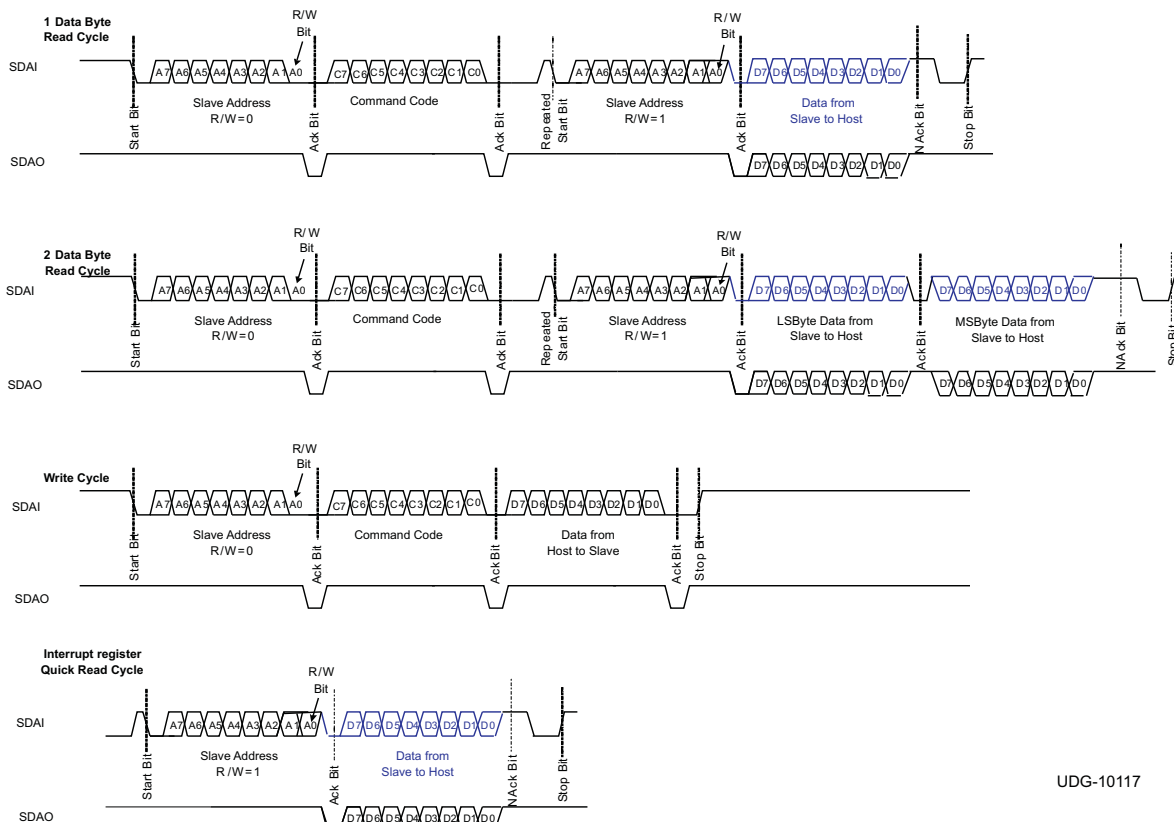

UDG-10117

Figure 28. I<sup>2</sup>C/SMBus Interface Read And Write Protocol

## Foldback and High Power Mode

For a robust design, a current foldback function limits the power dissipation of the MOSFET during low resistance load or a short circuit event. Using the TPS23851, it is possible to select one of two foldback profiles. The first one is for 802.3af applications, while the second one (2X mode) is for higher power applications as defined in the 802.3at standard. See [Figure 29](#) and [Figure 30](#).

The HPWn bit of the High Power and Sine Disable Register needs to be set to select the High Power Mode.

The linear foldback mechanism measures the port voltage across AGND and OUTn to reduce the current limit threshold from 100% at 18 V (28 V if in 2X mode) down to around 14% at a port voltage of 0 V.

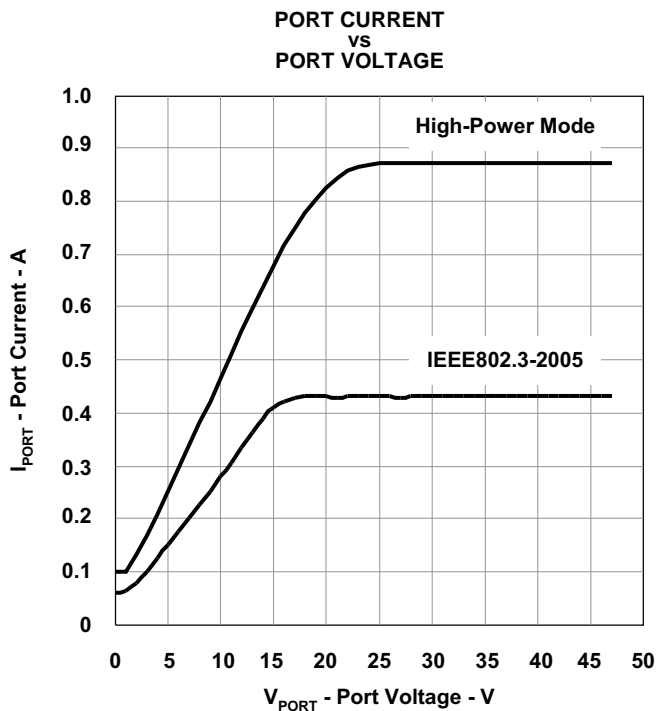

**Figure 29. Output Current Foldback Function (In IEEE Std 802.3at-2009 Mode and High-Power Mode)**

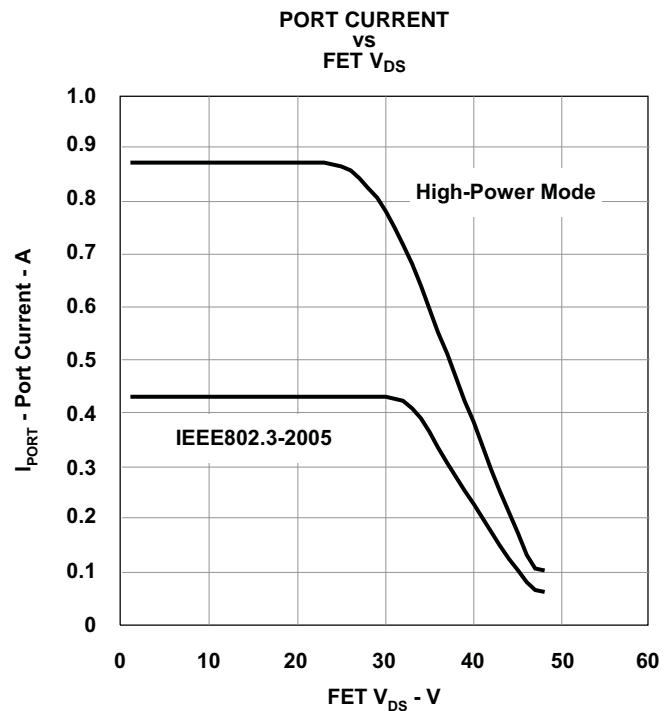

**Figure 30. Output Current Foldback Function (With VEE = -48 V, in IEEE Std 802.3at-2009 Mode and High-Power Mode)**

## Inrush Control, ICUT Fault Control

During a port turn on, the port MOSFET is turned on with di/dt control, which means that an internal current limiting amplifier forces the load current to track an internally defined voltage ramp. The  $t_{START}$  fault timer is also started at port turn on. If at the end of  $t_{START}$  time period the port is still in current limit, the port shuts off and its STRTn fault bit is set (Start Event Register).

### NOTE

During inrush period, the regular (1x) current foldback is used, regardless of the state of the HPWn bit in High Power and Sine Disable Register.

Once the  $t_{START}$  fault timer has expired without a fault, the  $t_{ICUT}$  timer becomes effective. It starts when  $I_{CUT}$  threshold is exceeded while a port is on. During that time, linear current limiting makes sure the current will not exceed  $I_{LIM}$  combined with current foldback action. When the timer reaches its  $t_{ICUT}$  limit, the port shuts off and its ICUTn bit is set (Fault Event Register). When the port current goes below  $I_{CUT}$ , while there is no foldback action, the counter counts down at a rate  $1/16^{th}$  of the increment rate and it must reach a count of zero before the port can be turned on again.

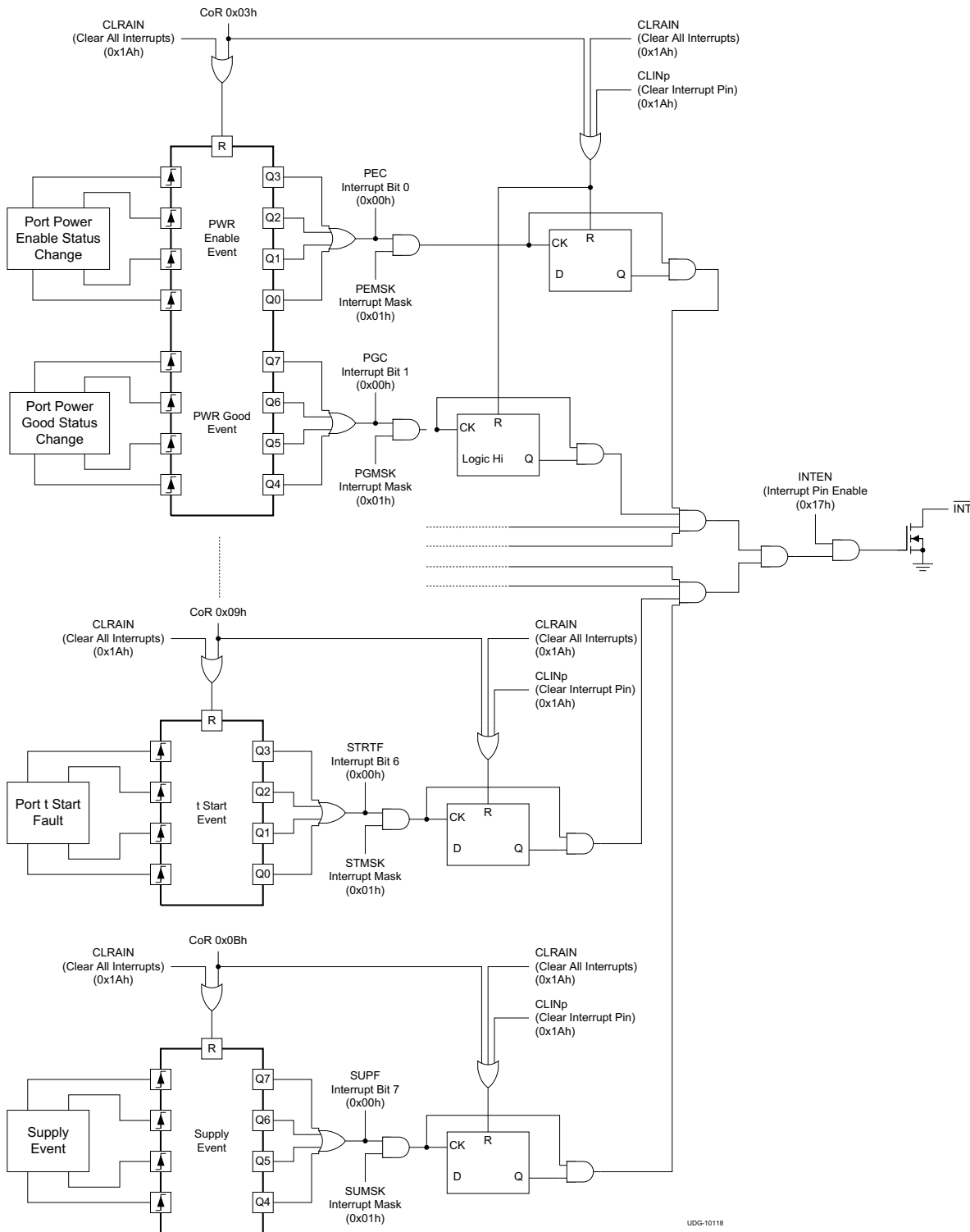

Figure 31. Interrupt Logic Functional Diagram

## APPLICATION INFORMATION

### Introduction to POE

Power-Over-Ethernet (POE) is a means of distributing power to Ethernet devices over the Ethernet cable using either data or spare pairs. POE eliminates the need for power supplies at the Ethernet device. Common applications of POE are security cameras, IP Phones and PDA chargers. The host or mid-span equipment that supplies power is the Power Source Equipment (PSE). The load at the Ethernet connector is the Powered device (PD). POE protocol between PSE and PD controlling power to the load is specified by IEEE Std 802.3at-2009.

Transformers are used at Ethernet host ports, mid-spans and hubs, to interface data to the cable. A DC voltage can be applied to the center tap of the transformer with no effect on the data signals. As in any power transmission line, a relatively high 48 V is used to keep current low, minimize the effect of IR drops in the line and preserve power to the load. Standard POE delivers approximately 13 W to the PD. [Figure 35](#) shows the overview schematic of a POE port.

### POE States Introduction

The PSE and PD operate under a three state protocol to complete the power connection. At initialization or when the port is disconnected, the PSE controller enters the detection state. In detection, the PD places a 25-k $\Omega$  signature resistor across the wire pair. The TPS23851 controller outputs a small current and checks the voltage to determine a valid PD signature. When a valid PD is found, the PSE controller enters the classification state to find out how much current the device requires. The PSE outputs a fixed 17.5 V and reads the current taken by the PD at this level. The current is converted to a device class. The PSE then enters the power on state. The PSE powers the port and continuously monitors the current supplied to the PD. See [Figure 26](#).

The port remains on as long as the port load is less than  $I_{CUT}$ , which is the maximum current allowed. Once a port load is above  $I_{CUT}$  or is disconnected or faulted, the port is powered down.

### Detection

To eliminate the possibility of false detection, the TPS23851 uses a TI proprietary 4-point detection method to determine the signature resistance of the PD device. False detection of a 25-k $\Omega$  signature can occur with 2-point detection type PSE's in noisy environments or if the load is highly capacitive.

Both detection 1 and detection 2 are merged into a single detection function which is repeated. Detection 1 applies  $I_1$  (165  $\mu$ A) to a port, waits 80 ms and then measures the port voltage  $V_1$  with the integrating ADC. Detection 2 applies  $I_2$  (275  $\mu$ A) to a port, waits 80 ms and measures the port voltage  $V_2$ . The process is repeated a second time. Multiple comparisons and calculations are performed on all four measurement point combinations to eliminate the effects of a non-linear or hysteretic PD signature. The resulting port signature is then sorted into the appropriate category.

### Classification

802.3af (or 802.3at Type 1) classification (class) is performed by supplying a voltage and sampling the resulting current. To eliminate the high power of a classification event from occurring in the power controller chip, the TPS23851 makes use of the external power FET for classification.

During classification, the voltage on the gate node of the external MOSFET is part of a linear control loop. The control loop applies the appropriate MOSFET drive to maintain a differential voltage between GND and OUT of 17.5 V. During classification the voltage across the sense resistor in the source of the MOSFET is measured and converted to a Class level within the TPS23851. If a load short occurs during classification the MOSFET gate voltage is quickly reduced to a linearly controlled, short circuit value for the duration of the class event.

Classification results may be read through the I<sup>2</sup>C Detection Event and Port n Status Registers.

## Power On

Once the port has met the requirements of a valid POE load, the port is powered on.

## Port Operating Modes

Each port may operate in one of four modes:

1. **Auto:** The port operates autonomously. It performs detection continuously until a valid PD is detected. Once a PD is found, classification is performed and the port is powered up as specified within its registers. Classification has no effect on the power-on step. When the AUTO pin is pulled high on power-up, the TPS23851 operates the four ports in auto mode. If the AUTO pin is pulled low, the operation is controlled by the system software through the I<sup>2</sup>C interface. The power on setting of the AUTO pin can be changed at any time by the I<sup>2</sup>C Operating Mode Registers. If the AUTO Mode is to be selected through I<sup>2</sup>C while the AUTO pin voltage is low, additional registers also need to be changed accordingly. This includes the Interrupt Mask Register, Disconnect Enable Register, Detect/Class Enable Register.
2. **SemiAuto:** The port performs detection and classification (if valid detection occurs) continuously. Registers are updated each time a detection or classification occurs. The port power is not automatically turned on.
3. **Manual:** The port performs the functions indicated by its registers one time when Commanded. There is no automatic state change.
4. **Power Off:** The port is powered off and will not autonomously perform a detection, classification or power-on. In this mode, Status and Enable Bits for the associated port are reset.

## Disconnect

Disconnect is the automated process of turning off power to the port. When the port is unloaded or at least falls below minimum load it is necessary to turn off power to the port and restart detection. Two methods of determining the port is below minimum load are AC disconnect and DC disconnect.

### DC Disconnect

In DC disconnect, the voltage across the sense resistors is measured. When enabled, the DC disconnect function monitors the sense resistor voltage of a powered port to verify the port is drawing at least the minimum current to remain active. The  $T_{DIS}$  timer will count up whenever the port current is below a 7.5-mA threshold. If a timeout occurs, the port will be shut down and the corresponding disconnect bit in the Fault Event Register will be set. The  $T_{DIS}$  counter is reset each time the current goes continuously higher than the disconnect threshold for 17% of  $T_{MPDO}$ .

The timer will start counting from the beginning if an undercurrent condition occurs again. An internal 2- $\mu$ s analog filter on the SENSE pin provides glitch filtering. The  $T_{DIS}$  duration is set by the  $T_{DIS}$  Bits of the Timing Configuration Register (0x16).

### AC Disconnect

The TPS23851 can detect a PD disconnect using AC or DC measurement.

AC disconnect consists in sensing the load impedance by injecting an AC voltage (110-Hz sinewave) at DETn pin and measuring the resultant current through the same pin. If the impedance is higher than a defined threshold, a timer ( $T_{DIS}$ ) is started and if a time-out occurs the port is turned off.

Also, the corresponding disconnect bit (DISFn) in the Fault Event Register is set accordingly. The  $T_{DIS}$  counter is reset each time the impedance goes lower than the disconnect threshold.

Referring to Figure 32, each DETn pin is connected to its output port through a 1 kΩ in series with a 0.47 μF, both in parallel with a low leakage diode. The AC disconnect technique requires a diode to be inserted in series with the power MOSFET as shown in Figure 32. This diode must be a S1B or equivalent. Also, the capacitance across the port on PSE is critical for accurate detection and must be close to 0.1 μF. Also consider that ceramic capacitors are strongly dependent on DC bias voltage, capacitance going down substantially at higher voltage. For these reasons, using X7R type with 100-V rating or equivalent is required.

The A/D converter is used to perform AC disconnect detection. A port's AC disconnect current is measured as the DC equivalent of the full-wave rectified AC current that circulates in and out of the DETn pin.

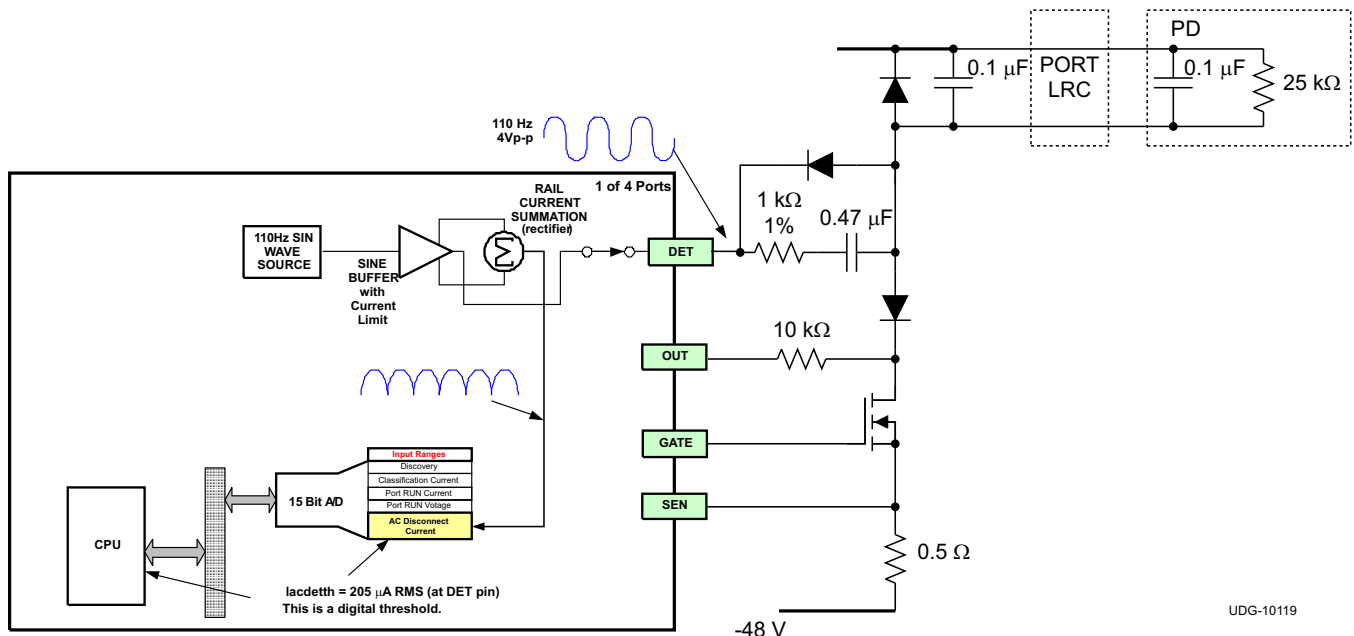

Figure 32. AC Disconnect Block Diagram



## Biassing Opto-Isolators

A worst case design for opto-isolators ensures operation over input voltage and temperature range. The following design example can be applied to any opto or system specifications. This example uses HCPL0631.

The bias on the isolator should meet minimum current specifications when the input voltage is minimum (3.0 V) and the temperature is high (85°C). The bias is then checked when the the applied voltage is high (3.5 V) and the temperature is minimum (-20°C). The result is that the maximum forward current is within isolator specifications. Different vendors HCPL-0631 datasheets show minimum  $I_F$  from 5 mA to 6.7 mA. Allowing for specifications and aging of the isolator, choose 6.3-mA minimum current. Next, use the isolator datasheet graphs to determine  $V_F$  at -20°C as 1.46 V and  $V_F$  at 85°C as 1.67 V.

### NOTE

The  $V_f$  goes down at high temperature, while the  $R_{dson}$  of SDAO FET goes up, so that a worst case 1.67V at high temperature is a good assumption.

Minimum bias, low input voltage.

$$V_{SDAO} = 6.3\text{mA} \times 118\Omega = 0.74\text{V} \quad (1)$$

$$V_R = V_{DD} - V_{SDAO} - V_F = 3.0 - 0.74 - 1.67 = 0.59\text{V} \quad (2)$$

$$\frac{V_R}{V_F} = \frac{0.59\text{V}}{0.0063} = 93.6\Omega, \text{ use } 95.3\Omega \quad (3)$$

After setting low voltage bias, check for safe high voltage bias.

$$V = V_{DD} - V_F = 3.5\text{V} - 1.47\text{V} = 2.03\text{V} \quad (4)$$

$$I_F = \frac{V}{(R_{BIAS} + R_{SDAO})} = \frac{2.03}{(95.3 + 78)} = 11.7\text{mA} \quad (5)$$

Isolator data sheet specs 15 mA max.

## I<sup>2</sup>C Watchdog

An I<sup>2</sup>C Watchdog time is available on the Texas Instruments TPS23851 device. When enabled, the timer will monitor the I<sup>2</sup>C, SCL line for clock edges. A timeout of the watchdog will reset the I<sup>2</sup>C interface along with any active ports. This feature provides protection in the event of rogue system software or I<sup>2</sup>C bus hang-up by slave devices. In the latter case, if a slave is attempting to send a data bit of "0" when the master stops sending clocks, then the slave could get stuck driving the data line low indefinitely. Since the data line is being driven low, the master cannot send a STOP to clean up the bus. Activating the I<sup>2</sup>C watchdog feature of the TPS23851 would clear this deadlocked condition. If the timer of 2 seconds expires, the ports will latch off and WD Status bit will be set. WD Status can only be cleared by a reset or writing a 0 to the WDS status bit location. The 4-bit watchdog disable field will shutdown this feature when a code of 1011b is loaded. This field is preset to 1011b whenever the TPS23851 is initially powered. The Watchdog Timer is divided from the main 7.4-MHz clock. Also see the I<sup>2</sup>C Watchdog Register for more details on the subject.

## Port Output Construction and Component Selection

Port output components can be seen in the applications schematic lower left, [Figure 35](#). The output port has a TVS (D1) for protection against voltage transients. The TVS shown was selected for 68-V breakdown, uni-directional, 600 W with less than 5- $\mu$ A leakage. A 0.1  $\mu$ F, X7R capacitor (C9) rated at 100 V provides minimal filtering and stability to the output.

The series RC (R7, C10) with parallel diode (D2) and Diode D3 are needed for AC disconnect only. These components are described in the AC disconnect section. If DC disconnect is used, they are omitted. MOSFET, Q2 is the port power switch controlled by the TPS23851. The MOSFET is used to power to the port connected device and also during classification.

TPS23851 reads the voltage at sense resistors (R13 and R14) to determine the port current. Port current is measured as the voltage drop across the external 0.5- $\Omega$  sense resistor. Two 1- $\Omega$  resistors wired in parallel are recommended. Two resistors improve the overall resistor tolerance and spread out the heat dissipation minimizing the effects of self heating.

## Layout

Sense readback should be wired in a Kelvin connection to the sense resistors. It is important to read voltage directly across the sense resistor to get a true measure of the current to the port load. Do not use other sense or GND points that may be electrical equivalents to these signals in the design layout tool. Read errors will occur because of stray current from other sources. Similarly, care must be taken to keep the flow of port current direct from the power source, through the pass FET to the sense resistors and to the return. This will minimize crosstalk between port loads and provide accurate current sense.

Accurate current readings are essential because they are used for sensitive measurements such as DC disconnect, classification, port loading and output faults.

### NOTE

For more details on TPS23851 layout recommendations, see TI document SLUU451.

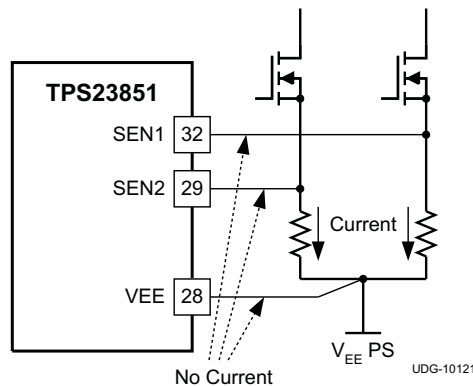

Figure 34. Current Sensing Resistor Layout

## MOSFET Selection

MOSFET selection is based on a number of key parameters listed in the MOSFET datasheet. An N-channel MOSFET is used. The IRFM120A or equivalent is recommended.

- **V<sub>DS</sub>**: The system voltage is 48 V and could operate as high as 53V. There must be some allowance for transients in inductive cables. Use 100-V parts as a good safety factor for 48-V systems.
- **R<sub>DS(on)</sub>**: The on resistance of the MOSFET determines the power to be dissipated at a given load. The commonly used parts have about a 0.2- $\Omega$  on resistance
- **ID**: The current capability of the device, while important, is not sufficient for device selection. The maximum safe operating area curve gives the drain current (ID) vs drain-to-source voltage (VDS) curve. This is usually a family of curves for an on time duration. This data is given for 25°C. It must therefore be de-rated by the thermal response for pulse duration.

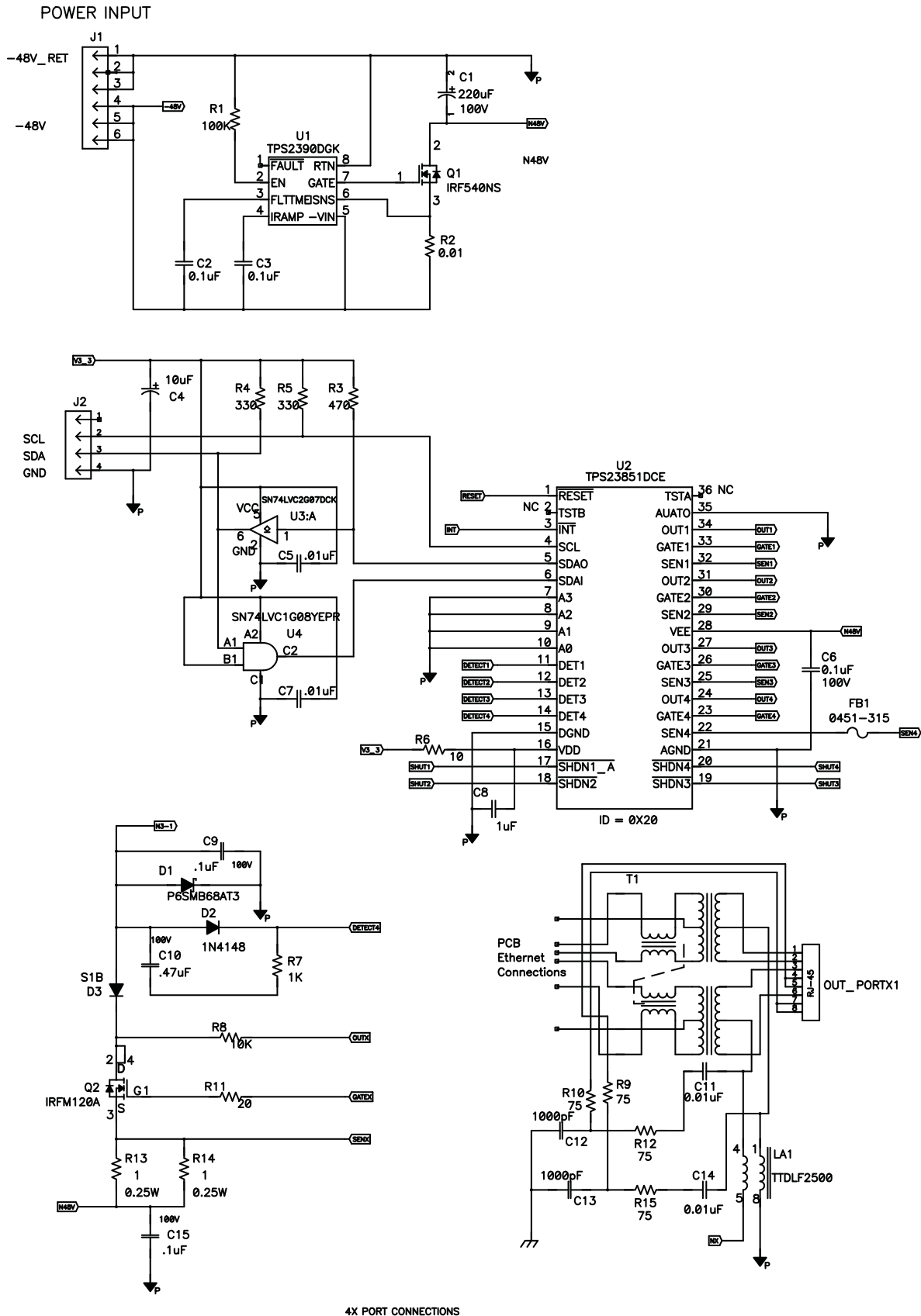

Figure 35. TPS23851 Application Schematic With AC Disconnect Detection

**Table 1. Summary of Main Registers <sup>(1)</sup>**

CMD CODE	REGISTER OR COMMAND NAME	R/W	DATA BYTE	RST State	BITS DESCRIPTION							
					SUPF	STRTF	ICUTF	CLAS C	DETC	DISF	PGC	PEC
00h	Interrupt	RO	1	1000,0000b	SUPF	STRTF	ICUTF	CLAS C	DETC	DISF	PGC	PEC
01h	Interrupt mask	R/W	1	1AA0,0A00b	SUMSK	STMSK	ICMS K	CLMS K	DEMSK	DIMSK	PGMS K	PEMSK
02h	Power status	RO	1	0000,0000b	Power Good status change				Power Enable status change			
03h		CoR	1		PGC4	PGC3	PGC2	PGC1	PEC4	PEC3	PEC2	PEC1
04h	Detection status	RO	1	0000,0000b	Classification occurred				Detection occurred			
05h		CoR	1		CLSC4	CLSC3	CLSC 2	CLSC 1	DETC4	DETC3	DETC2	DETC1
06h	Fault status	RO	1	0000,0000b	Disconnect occurred				ICUT fault occurred			
07h		CoR	1		DISF4	DISF3	DISF2	DISF1	ICUT4	ICUT3	ICUT2	ICUT1
08h	Start status	RO	1	0000,0000b	START fault occurred							
09h		CoR	1		-	-	-	-	STRT4	STRT3	STRT2	STRT1
0Ah	Supply event	RO	1	0010,0010b	TSD	-	VDUV	VEUV	-	-	OSCF	-
0Bh		CoR	1		-	-	-	-	-	-	-	-
0Ch	Port 1 status	RO	1	0000,0000b	-	CLASS Port 1		-	DETECT Port 1			
0Dh	Port 2 status	RO	1	0000,0000b	-	CLASS Port 2		-	DETECT Port 2			
0Eh	Port 3 status	RO	1	0000,0000b	-	CLASS Port 3		-	DETECT Port 3			
0Fh	Port 4 status	RO	1	0000,0000b	-	CLASS Port 4		-	DETECT Port 4			
10h	Power status	RO	1	0000,0000b	PG4	PG3	PG2	PG1	PE4	PE3	PE2	PE1
11h	Pin status	RO	1	00,A[3:0],0,A	-	-	SLA3	SLA2	SLA1	SLA0	-	AUTO
12h	Operating mode	R/W	1	AAAA,AAAAb	Port 4 Mode		Port 3 Mode		Port 2 Mode		Port 1 Mode	
13h	Disconnect enable	R/W	1	AAAA,0000b	ACDE4	ACDE3	ACDE 2	ACDE 1	DCDE4	DCDE3	DCDE2	DCDE1
14h	Detect/class enable	R/W	1	AAAA,AAAAb	CLE4	CLE3	CLE2	CLE1	DETE4	DETE3	DETE2	DETE1
16h	Timing configuration	R/W	1	0000,0000b	-	TSTART		TICUT		TDIS		
17h	General mask	R/W	1	1010,0000b	INTEN	-	OSC MSK	-	-	-	-	-
18h	Detect/class restart	WO	1	0000,0000b	RCL4	RCL3	RCL2	RCL1	RDET4	RDET3	RDET2	RDET1
19h	Power enable	WO	1	0000,0000b	POFF4	POFF3	POFF 2	POFF 1	PWON 4	PWON 3	PWON 2	PWON 1
1Ah	Reset	WO	1	0000,0000b	CLRAIN	CLINP	-	RESA L	RESP4	RESP3	RESP2	RESP1
1Bh	ID	RO	1	Mf[4:0],IC[2:0]	MFR ID					IC Version		
2Ah	ICUT21 configuration	R/W	1	0000,0000b	-	ICUT Port 2		-	ICUT Port 1			
2Bh	ICUT43 configuration	R/W	1	0000,0000b	-	ICUT Port 4		-	ICUT Port 3			

(1) A = Auto pin logical value at POR

**Table 1. Summary of Main Registers <sup>(1)</sup> (continued)**

CMD CODE	REGISTER OR COMMAND NAME	R/W	DATA BYTE	RST State	BITS DESCRIPTION								
30h	Port 1 current	RO	2	0000,0000b	Port 1 Current: LSByte								
31h		RO		0000,0000b	-	AC1	Port 1 Current: MSByte (bits 13 to 8)						
32h	Port 1 voltage	RO	2	0000,0000b	Port 1 Voltage: LSByte								
33h		RO		0000,0000b	-	-	Port 1 Voltage: MSByte (bits 13 to 8)						
34h	Port 2 current	RO	2	0000,0000b	Port 2 Current: LSByte								
35h		RO		0000,0000b	-	AC2	Port 2 Current: MSByte (bits 13 to 8)						
36h	Port 2 voltage	RO	2	0000,0000b	Port 2 Voltage: LSByte								
37h		RO		0000,0000b	-	-	Port 2 Voltage: MSByte (bits 13 to 8)						
38h	Port 3 current	RO	2	0000,0000b	Port 3 current: LSByte								
39h		RO		0000,0000b	-	AC3	Port 3 Current: MSByte (bits 13 to 8)						
3Ah	Port 3 voltage	RO	2	0000,0000b	Port 3 Voltage: LSByte								
3Bh		RO		0000,0000b	-	-	Port 3 Voltage: MSByte (bits 13 to 8)						
3Ch	Port 4 current	RO	2	0000,0000b	Port 4 current: LSByte								
3Dh		RO		0000,0000b	-	AC4	Port 4 Current: MSByte (bits 13 to 8)						
3Eh	Port 4 voltage	RO	2	0000,0000b	Port 4 Voltage: LSByte								
3Fh		RO		0000,0000b	-	-	Port 4 Voltage: MSByte (bits 13 to 8)						
40h	High power and sine disable	R/W	1	0000,0000b	HPW4	HPW3	HPW2	HPW1	SNDI	-	-	-	
41h	Firmware revision	RO	1	0000,0RRRb	Firmware Revision								
42h	I <sup>2</sup> C watchdog	R/W	1	0001,0110b	Watchdog Disable							WDS	
43h	device ID	R/W	1	1010,0,sr[2:0]	Device ID number				Silicon Revision number				

**Table 2. Special Function Registers**

CMD CODE	REGISTER OR COMMAND NAME	R/W	DATA BYTES	RST STATE	BITS DESCRIPTION							
1Dh	Test enable	R/W	1	0000,0000b	Unlock code							
22h	Multiplexed shutdown configuration	R/W	1	0000,0000b	-			MUX shutdown config				
					-	-	-	MSE	MSE4	MSE3	MSE2	MSE1

## Interrupt Register

### Command = 00h With 1 Data Byte, Read Only

BITS	D7	D6	D5	D4	D3	D2	D1	D0
BIT NAME	SUPF	STRTF	ICUTF	CLASC	DETC	DISF	PGC	PEC
RESET OR POR VALUE	1	0	0	0	0	0	0	0

### Bit Descriptions

Active high, each bit corresponds to a particular event that occurred.

Each bit can be individually reset by doing a read at the corresponding event register address, or by setting bit 7 of Reset Register.

Any active bit of Interrupt Register will activate the  $\overline{INT}$  output if its corresponding Mask bit in Interrupt Mask Register (01h) is set, as well as the INTEN bit in the General Mask Register.

**SUPF:** Indicates that a Supply Event Fault occurred.

SUPF = TSD || VDUV || VEUV || OSCF

- 1 = At least one Supply Event Fault occurred
- 0 = No such event occurred

**STRTF:** Indicates that a  $t_{START}$  fault occurred on at least one port.

STRTF = STRT1 || STRT2 || STRT3 || STRT4

- 1 =  $t_{START}$  fault occurred for at least one port
- 0 = No  $t_{START}$  fault occurred

**ICUTF:** Indicates that a  $t_{CUT}$  fault occurred on at least one port.

ICUTF = ICUT1 || ICUT2 || ICUT3 || ICUT4

- 1 =  $t_{CUT}$  fault occurred for at least one port
- 0 = No  $t_{CUT}$  fault occurred

**CLASC:** Indicates that at least one classification cycle occurred on at least one port.

CLASC = CLSC1 || CLSC2 || CLSC3 || CLSC4

- 1 = At least one classification cycle occurred for at least one port
- 0 = No classification cycle occurred

**DETC:** Indicates that at least one detection cycle occurred on at least one port.

DETC = DETC1 || DETC2 || DETC3 || DETC4

- 1 = At least one detection cycle occurred for at least one port
- 0 = No detection cycle occurred

**DISF:** Indicates that a disconnect event occurred on at least one port.

DISF = DISF1 || DISF2 || DISF3 || DISF4

- 1 = Disconnect event occurred for at least one port
- 0 = No disconnect event occurred

**PGC:** Indicates that a power good status change occurred on at least one port.

PGC = PGC1 || PGC2 || PGC3 || PGC4

- 1 = Power good status change occurred on at least one port
- 0 = No power good status change occurred

**PEC:** Indicates that a power enable status change occurred on at least one port.

PEC = PEC1 || PEC2 || PEC3 || PEC4

- 1 = Power enable status change occurred on at least one port
- 0 = No power enable status change occurred

---

**NOTE**

The register pointer is always reset after a Stop Bit on I<sup>2</sup>C bus. This allows a quick access to the interrupt register through I<sup>2</sup>C bus.

---

## Interrupt Mask Register

### Command = 01h with 1 Data Byte, Read/Write<sup>(1)</sup>

BITS	D7	D6	D5	D4	D3	D2	D1	D0
BIT NAME	SUMSK	STMSK	ICMSK	CLMSK	DEMSK	DIMSK	PGMSK	PEMSK
RESET OR POR VALUE	1	A	A	0	0	A	0	0

(1) A = Auto pin logical value at POR

### Bit Descriptions

Each bit corresponds to a particular event or fault as defined in the Interrupt Register.

Writing a 0 into a bit will mask the corresponding event/fault from activating the  $\overline{\text{INT}}$  output.

---

#### NOTE

1. The bits of the Interrupt Register always change state according to events or faults, regardless of the state of the state of the Interrupt Mask Register.
  2. The INTEN bit of the General Mask Register must also be set in order to allow an event to activate the  $\overline{\text{INT}}$  output.
- 

**SUMSK:** Supply Event Fault mask bit.

- 1 = Supply event fault will activate the  $\overline{\text{INT}}$  output.
- 0 = Supply event fault will have no impact on  $\overline{\text{INT}}$  output.

**STMSK:**  $t_{\text{START}}$  fault mask bit.

- 1 =  $t_{\text{START}}$  fault will activate the  $\overline{\text{INT}}$  output.
- 0 =  $t_{\text{START}}$  fault will have no impact on  $\overline{\text{INT}}$  output.

**ICMSK:**  $t_{\text{CUT}}$  fault mask bit.

- 1 =  $t_{\text{CUT}}$  fault occurrence will activate the  $\overline{\text{INT}}$  output.
- 0 =  $t_{\text{CUT}}$  fault occurrence will have no impact on  $\overline{\text{INT}}$  output.

**CLMSK:** Classification cycle mask bit.

- 1 = Classification cycle occurrence will activate the  $\overline{\text{INT}}$  output.
- 0 = Classification cycle occurrence will have no impact on  $\overline{\text{INT}}$  output

**DEMSK:** Detection cycle mask bit.

- 1 = Detection cycle occurrence will activate the  $\overline{\text{INT}}$  output.
- 0 = Detection cycle occurrence will have no impact on  $\overline{\text{INT}}$  output.

**DIMSK:** Disconnect event mask bit.

- 1 = Disconnect event occurrence will activate the  $\overline{\text{INT}}$  output.
- 0 = Disconnect event occurrence will have no impact on  $\overline{\text{INT}}$  output.

**PGMSK:** Power good status change mask bit.

- 1 = Power-good status change will activate the  $\overline{\text{INT}}$  output.
- 0 = Power-good status change will have no impact on  $\overline{\text{INT}}$  output.

**PEMSK:** Power Enable status change mask bit.

- 1 = Power enable status change will activate the  $\overline{\text{INT}}$  output.
- 0 = Power enable status change will have no impact on  $\overline{\text{INT}}$  output.

**Power Event Register****Command = 02h with 1 Data Byte, Read Only****Command = 03h With 1 Data Byte, Clear On Read**

BITS	D7	D6	D5	D4	D3	D2	D1	D0
<b>BIT NAME</b>	PGC4	PGC3	PGC2	PGC1	PEC4	PEC3	PEC2	PEC1
<b>RESET OR POR VALUE</b>	0	0	0	0	0	0	0	0

**Bit Descriptions**

Active high, each bit corresponds to a particular event that occurred.

Each bit xxx1-4 represents an individual port.

A read at each location (02h or 03h) returns the same register data with the exception that the Clear on Read Command clears all bits of the register.

If this register is causing the  $\overline{\text{INT}}$  pin to be activated, this Clear on Read will release the  $\overline{\text{INT}}$  pin.

Any active bit will have an impact on the Interrupt Register as indicated in the Interrupt Register description.

**PGC4-PGC1:** Indicates that a power-good status change occurred.

- 1 = Power-good status change occurred
- 0 = No power good status change occurred

**PEC4-PEC1:** Indicates that a power enable status change occurred.

- 1 = Power enable status change occurred
- 0 = No power enable status change occurred

**Detection Event Register****Command = 04h With 1 Data Byte, Read Only****Command = 05h With 1 Data Byte, Clear On Read**

BITS	D7	D6	D5	D4	D3	D2	D1	D0
<b>BIT NAME</b>	CLSC4	CLSC3	CLSC2	CLSC1	DETC4	DETC3	DETC2	DETC1
<b>RESET OR POR VALUE</b>	0	0	0	0	0	0	0	0

**Bit Descriptions**

Active high, each bit corresponds to a particular event that occurred.

Each bit xxxx1-4 represents an individual port.

A read at each location (04h or 05h) returns the same register data with the exception that the Clear on Read command clears all bits of the register.

If this register is causing the  $\overline{\text{INT}}$  pin to be activated, this Clear on Read will release the  $\overline{\text{INT}}$  pin.

Any active bit will have an impact on the Interrupt Register as indicated in the Interrupt Register description.

**CLSC4- CLSC1:** Indicates that at least one classification cycle occurred.

- 1 = At least one classification cycle occurred
- 0 = No classification cycle occurred

**DETC4-DETC1:** Indicates that at least one detection cycle occurred.

- 1 = At least one detection cycle occurred
- 0 = No detection cycle occurred

**Fault Event Register**
**Command = 06h With 1 Data Byte, Read Only**
**Command = 07h With 1 Data Byte, Clear On Read**

BITS	D7	D6	D5	D4	D3	D2	D1	D0
BIT NAME	DISF4	DISF3	DISF2	DISF1	ICUT4	ICUT3	ICUT2	ICUT1
RESET OR POR VALUE	0	0	0	0	0	0	0	0

**Bit Descriptions**

Active high, each bit corresponds to a particular event that occurred.

Each bit xxxx1-4 represents an individual port.

A read at each location (06h or 07h) returns the same register data with the exception that the Clear on Read Command clears all bits of the register.

If this register is causing the  $\overline{\text{INT}}$  pin to be activated, this Clear on Read will release the  $\overline{\text{INT}}$  pin.

Any active bit will have an impact on the Interrupt Register as indicated in the Interrupt Register description.

**DISF4-DISF1:** Indicates that a disconnect event occurred.

- 1 = Disconnect event occurred
- 0 = No disconnect event occurred

**ICUT4-ICUT1:** Indicates that a  $t_{\text{ICUT}}$  fault occurred.

- 1 =  $t_{\text{ICUT}}$  fault occurred
- 0 = No  $t_{\text{ICUT}}$  fault occurred

**Start Event Register**
**Command = 08h with 1 Data Byte, Read Only**
**Command = 09h With 1 Data Byte, Clear On Read**

BITS	D7	D6	D5	D4	D3	D2	D1	D0
BIT NAME	-	-	-	-	STRT4	STRT3	STRT2	STRT1
RESET OR POR VALUE	0	0	0	0	0	0	0	0

**Bit Descriptions**

Active high, each D3-D0 bit corresponds to a particular event that occurred.

Each bit xxxx1-4 represents an individual port. Bits D7-D4 are reserved for future use.

A read at each location (08h or 09h) returns the same register data with the exception that the Clear on Read command clears all bits of the register.

If this register is causing the  $\overline{\text{INT}}$  pin to be activated, this Clear on Read will release the  $\overline{\text{INT}}$  pin.

Any active bit will have an impact on the INTERRUPT register as indicated in the INTERRUPT register description.

**STRT4-STRT1:** Indicates that a  $t_{\text{START}}$  Fault occurred.

- 1 =  $t_{\text{START}}$  fault occurred
- 0 = No  $t_{\text{START}}$  fault occurred

**Supply Event Register**  
**Command = 0Ah with 1 Data Byte, Read Only**  
**Command = 0Bh With 1 Data Byte, Clear On Read**

BITS	D7	D6	D5	D4	D3	D2	D1	D0
<b>BIT NAME</b>	TSD	-	VDUV	VEUV	-	-	OSCF	-
<b>POR VALUE IF VDD COMES UP FIRST</b>	0	0	1	1	0	0	1	0
<b>POR VALUE IF VEE COMES UP FIRST</b>	0	0	1	0	0	0	1	0

### Bit Descriptions

Active high, each bit corresponds to a particular event that occurred.

Bits D6, D3, D2 and D0 are reserved for future use.

A read at each location (0Ah or 0Bh) returns the same register data with the exception that the Clear on Read command clears all bits of the register.

If this register is causing the  $\overline{\text{INT}}$  pin to be activated, this Clear on Read will release the  $\overline{\text{INT}}$  pin.

Any active bit will have an impact on Interrupt Register as indicated in the Interrupt Register description.

**TSD:** Indicates that a thermal shutdown occurred.

- 1 = Thermal shutdown occurred
- 0 = No thermal shutdown occurred

**VDUV:** Indicates that a VDD UVLO occurred. This means that a power-on reset occurred.

- 1 = VDD UVLO occurred
- 0 = No VDD UVLO occurred

**VEUV:** Indicates that a VEE UVLO occurred while VDD was maintained higher than its UVLO threshold.

- 1 = VEE UVLO occurred
- 0 = No VEE UVLO occurred

**OSCF:** Indicates that an invalid AC disconnect oscillator condition occurred.

- 1 = Invalid AC disconnect oscillator condition occurred
- 0 = No invalid AC disconnect oscillator condition occurred

### NOTE

1. If the  $\overline{\text{RESET}}$  input is pulled low during normal operation, the OSCF bit will be set while the VEUV will be set if VEE is below its UVLO threshold. There is no impact on VDUV since VDD is maintained.
2. When VEE UVLO condition occurs while ports are ON, these ports are turned off and the Power Status and Power Event Registers are updated accordingly.

**Port 1 Status Register**  
**Command = 0Ch With 1 Data Byte, Read Only**

BITS	D7	D6	D5	D4	D3	D2	D1	D0
BIT NAME	-	CLASS P1			-	DETECT P1		
RESET OR POR VALUE	0	0	0	0	0	0	0	0

**Port 2 Status Register**  
**Command = 0Dh With 1 Data Byte, Read Only**

BITS	D7	D6	D5	D4	D3	D2	D1	D0
BIT NAME	-	CLASS P2			-	DETECT P2		
RESET OR POR VALUE	0	0	0	0	0	0	0	0

**Port 3 Status Register**  
**Command = 0Eh With 1 Data Byte, Read Only**

BITS	D7	D6	D5	D4	D3	D2	D1	D0
BIT NAME	-	CLASS P3			-	DETECT P3		
RESET OR POR VALUE	0	0	0	0	0	0	0	0

**Port 4 Status Register**  
**Command = 0Fh With 1 Data Byte, Read Only**

BITS	D7	D6	D5	D4	D3	D2	D1	D0
BIT NAME	-	CLASS P4			-	DETECT P4		
RESET OR POR VALUE	0	0	0	0	0	0	0	0

**Bit Descriptions:**

Represents the most recent classification and detection results for port n. These bits are cleared when port n is turned off.

**CLASS Pn:** Most recent classification result on Port n.

The selection is as following:

**Table 3. Classification Result On Port n**

CLASS Pn			CLASS STATUS
0	0	0	unknown
0	0	1	Class 1
0	1	0	Class 2
0	1	1	Class 3
1	0	0	Class 4
1	0	1	Reserved – read as Class 0
1	1	0	Class 0
1	1	1	Overcurrent

**DETECT Pn:** Most recent detection result on port n.

The selection is as following:

**Table 4. Detection Result On Port n<sup>(1)</sup>**

DETECT Pn			DETECT STATUS
0	0	0	unknown
0	0	1	Short-circuit (< 150 Ω)
0	1	0	Reserved
0	1	1	Too Low
1	0	0	Valid
1	0	1	Too High
1	1	0	Open Circuit
1	1	1	Reserved

(1) Code 000 is shown as “Unknown” which is the code to indicate that the PSE controller has never has never inspected the port since the last reset. Once a least one detection cycle has completed, the result will never occur again.

**Power Status Register  
Command = 10h With 1 Data Byte, Read Only**

BITS	D7	D6	D5	D4	D3	D2	D1	D0
BIT NAME	PG4	PG3	PG2	PG1	PE4	PE3	PE2	PE1
RESET OR POR VALUE	0	0	0	0	0	0	0	0

**Bit Descriptions**

Each bit represents the actual power status of a port.

Each bit xx1-4 represents an individual port.

**PG4-PG1:** Each bit, when at 1, indicates that the port is on and that the voltage at OUTn pin has gone below the power good threshold during the port turn on.

These bits are latched high once the turn on is complete and can only be cleared when the port is turned off or at reset/POR.

- 1 = Power is good
- 0 = Power is not good

**PE4-PE1:** Each bit indicates the ON/OFF state of the corresponding port. Each bit is set to 1 when the PSE controller is attempting to supply power to the port. The bit remains at 1 for all conditions while power is applied, regardless of the actual port voltage or if some other functions, such as foldback, is limiting power to the port.

PEx is zero when the PSE is not trying to power the port, regardless of the port voltage. For example if power is being removed but the port has not fully discharged the status will report 0 as the PSE is not trying to power the port.

- 1 = Port is on
- 0 = Port is off

**Pin Status Register**  
**Command = 11h With 1 Data Byte, Read Only<sup>(1)</sup>**

BITS	D7	D6	D5	D4	D3	D2	D1	D0
BIT NAME	-	-	SLA3	SLA2	SLA1	SLA0	-	AUTO
RESET OR POR VALUE	0	0	A3 pin	A2 pin	A1 pin	A0 pin	-	A

(1) A = Auto pin logical value at POR.

**Bit Descriptions**

**AUTO:** State of the AUTO pin.

- 1 = AUTO is high
- 0 = AUTO is low

The logic state of the AUTO pin at POR determines the preset state for multiple registers of the TPS23851. After POR is complete, the state of the AUTO pin is reflected in bit D0 of the Pin Status Register only. In some applications, this behavior enables the AUTO pin to be used as a discrete input after POR.

**SLA3-SLA0:** State of A3-A0 pins representing the I<sup>2</sup>C slave address.

**Table 5. A3-A0 Pins Representing the I<sup>2</sup>C Slave Address**

DESCRIPTIO N	BINARY device ADDRESS							ADDRESS PINS			
	6	5	4	3	2	1	0	A3	A2	A1	A0
BROADCAST ACCESS	0	1	1	0	0	0	0	X	X	X	X
ALERT RESPONSE	0	0	0	1	1	0	0	X	X	X	X
SLAVE 0	0	1	0	0	0	0	0	GND	GND	GND	GND
SLAVE 1	0	1	0	0	0	0	1	GND	GND	GND	HIGH
SLAVE 2	0	1	0	0	0	1	0	GND	GND	HIGH	GND
SLAVE 3	0	1	0	0	0	1	1	GND	GND	HIGH	HIGH
SLAVE 4	0	1	0	0	1	0	0	GND	HIGH	GND	GND
SLAVE 5	0	1	0	0	1	0	1	GND	HIGH	GND	HIGH
SLAVE 6	0	1	0	0	1	1	0	GND	HIGH	HIGH	GND
SLAVE 7	0	1	0	0	1	1	1	GND	HIGH	HIGH	HIGH
SLAVE 8	0	1	0	1	0	0	0	HIGH	GND	GND	GND
SLAVE 9	0	1	0	1	0	0	1	HIGH	GND	GND	HIGH
SLAVE 10	0	1	0	1	0	1	0	HIGH	GND	HIGH	GND
SLAVE 11	0	1	0	1	0	1	1	HIGH	GND	HIGH	HIGH
SLAVE 12	0	1	0	1	1	0	0	HIGH	HIGH	GND	GND
SLAVE 13	0	1	0	1	1	0	1	HIGH	HIGH	GND	HIGH
SLAVE 14	0	1	0	1	1	1	0	HIGH	HIGH	HIGH	GND
SLAVE 15	0	1	0	1	1	1	1	HIGH	HIGH	HIGH	HIGH

## Operating Mode Register

### Command = 12h With 1 Data Byte, R/W<sup>(1)</sup>

BITS	D7	D6	D5	D4	D3	D2	D1	D0
BIT NAME	P4M1	P4M0	P3M1	P3M0	P2M1	P2M0	P1M1	P1M0
RESET OR POR VALUE	A	A	A	A	A	A	A	A

(1) A = Auto pin logical value at POR.

### Bit Descriptions

Each pair of bits configures the operating mode per port.

The selection is as following:

**Table 6. Bits Configuration**

M1 M0		OPERATING MODE
0	0	OFF
0	1	Manual
1	0	Semi Auto
1	1	Auto

In OFF Mode, the port is OFF and there is no detection nor classification. In Manual Mode, there is no automatic state change. In Semi Auto Mode, detection and class are automated but not the port power on, while in Auto Mode all three are automated.

## Disconnect Enable Register

### Command = 13h With 1 Data Byte, R/W<sup>(1)</sup>

BITS	D7	D6	D5	D4	D3	D2	D1	D0
BIT NAME	ACDE4	ACDE3	ACDE2	ACDE1	DCDE4	DCDE3	DCDE2	DCDE1
RESET OR POR VALUE	A	A	A	A	0	0	0	0

(1) A = Auto pin logical value at POR.

### Bit Descriptions

Defines the disconnect detection mechanism for each port.

**ACDE4-ACDE1:** AC disconnect enable. AC disconnect consists in sensing the load impedance by injecting an AC voltage and measuring the resultant current. If the impedance is higher than a defined threshold, a timer ( $T_{DIS}$ ) is started and if a timeout occurs the port is turned off. Also, the corresponding disconnect bit (DISFn) in the Fault Event Register is set accordingly. The  $T_{DIS}$  counter is reset each time the impedance goes lower than the disconnect threshold.

---

#### NOTE

The A/D converter is used to perform AC disconnect detection.

---

**DCDE4-DCDE1:** DC disconnect enable. DC disconnect consists in measuring the port DC current at SENn, starting a timer ( $T_{DIS}$ ) if this current is below a threshold and turning the port off if a timeout occurs. Also, the corresponding disconnect bit (DISFn) in the Fault Event Register is set accordingly. The  $T_{DIS}$  counter is reset each time the current goes continuously higher than the disconnect threshold for 17% of  $T_{MPDO}$ .

---

#### NOTE

DC disconnect detection is performed by use of an analog comparator.

---

Look at the Timing Configuration Register for more details on how to define the  $T_{DIS}$  time period.

**Detect/Class Enable Register**  
**Command = 14h With 1 Data Byte, R/W<sup>(1)</sup>**

BITS	D7	D6	D5	D4	D3	D2	D1	D0
BIT NAME	CLE4	CLE3	CLE2	CLE1	DETE4	DETE3	DETE2	DETE1
RESET OR POR VALUE	A	A	A	A	A	A	A	A

(1) A = Auto pin logical value at POR.

**Bit Descriptions**

Detection and classification enable for each port.

When in Manual Mode, setting a bit means that only one cycle (detection or classification) is performed for the corresponding port. The bit is automatically cleared when the cycle has been completed.

---

**NOTE**

1. Similar result can be obtained by writing to the Detect/Class Restart Register.
  2. A classification is done while using the external MOSFET so that doing a classification on more than one port at same time is possible without overdissipation in the TPS23851.
- 

**CLE4-CLE1:** Classification enable bits.

**DETE4-DETE1:** Detection enable bits.

**Timing Configuration Register**  
**Command = 16h With 1 Data Byte, R/W**

BITS	D7	D6	D5	D4	D3	D2	D1	D0
BIT NAME	-	-	TSTART		TICUT		TDIS	
RESET OR POR VALUE	0	0	0	0	0	0	0	0

**Bit Descriptions**

These bits define the timing configuration for all four ports.

**TSTART:** START fault timing, which is the maximum allowed overcurrent time during inrush.

The selection is as following:

**Table 7. TSTART: Start fault timing**

TSTART	NOMINAL $T_{START}$ (ms)
0	60
0	30
1	120
1	240

**TICUT:**  $I_{CUT}$  fault timing, which is the overcurrent time duration before port turn off.

This timer is active and increments to the settings defined below after expiration of the  $T_{START}$  time window and when the port current meets or exceeds  $I_{CUT}$ . If the  $I_{CUT}$  counter is allowed to reach the programmed time-out duration specified below, the port will be powered off. The counter continues to operate when the port is off (counting down) and the port can not be turned-on until the counter has reached a count of zero. When the port current is below  $I_{CUT}$ , while there is no foldback action, the same counter decrements at a rate  $1/16^{th}$  of the increment rate. The counter does not decrement below zero.

The selection is as following:

**Table 8. TICUT: ICUT Fault Timing**

TICUT	NOMINAL $T_{ICUT}$ (ms)
0	60
0	30
1	120
1	240

**TDIS:** Disconnect delay, which is the time to turn off a port once there is a disconnect condition, and if at least one of the two disconnect detect methods has been enabled.

The selection is as following:

**Table 9. TDIS: Disconnect Delay**

TDIS	NOMINAL $T_{DIS}$ (ms)
0	360
0	90
1	180
1	720

### General Mask Register

Command = 17h With 1 Data Byte, Read/Write

BITS	D7	D6	D5	D4	D3	D2	D1	D0
BIT NAME	INTEN	-	OSCMSK	-	-	-	-	-
RESET OR POR VALUE	1	-	1	-	-	-	-	-

#### Bit Descriptions

**INTEN:**  $\overline{\text{INT}}$  pin mask bit. Writing a 0 will mask any bit of Interrupt Register from activating the  $\overline{\text{INT}}$  output, whatever the state of the Interrupt Mask Register. Note that activating INTEN has no impact on the event registers.

- 1 = Any unmasked bit of Interrupt Register can activate the  $\overline{\text{INT}}$  output
- 0 =  $\overline{\text{INT}}$  output cannot be activated

**OSCMSK:** AC disconnect oscillator mask bit. If cleared, an oscillator failure will not set the OSCF bit of the Supply Event Register.

- 1 = An invalid oscillator condition will set the OSCF bit of Supply Event Register
- 0 = OSCF bit of Supply Event Register will stay low whatever the condition of the oscillator

### Detect/Class Restart Register

Command = 18h With 1 Data Byte, Write only

BITS	D7	D6	D5	D4	D3	D2	D1	D0
BIT NAME	RCL4	RCL3	RCL2	RCL1	RDET4	RDET3	RDET2	RDET1
RESET OR POR VALUE	0	0	0	0	0	0	0	0

#### Bit Descriptions

Each bit corresponds to a particular event per port.

Each event can be individually triggered by writing a “1” at that bit location, while writing a “0” does not change anything for that event.

In Manual mode, a single event will be triggered while in Auto or Semiauto mode, it sets the corresponding bit in the Detect/Class Enable Register.

A Read operation will return 00h.

---

#### NOTE

A classification is done while using the external MOSFET so that doing a classification on all ports at same time is allowed.

---

**RCL4-RCL1:** Restart classification bits.

**DETE4-DETE1:** Restart detection bits.

## Power Enable Register

### Command = 19h With 1 Data Byte, Write Only

BITS	D7	D6	D5	D4	D3	D2	D1	D0
BIT NAME	POFF4	POFF3	POFF2	POFF1	PWON4	PWON3	PWON2	PWON1
RESET OR POR VALUE	0	0	0	0	0	0	0	0

#### Bit Descriptions

Used to force an immediate port(s) turn on or turn off in any mode except Shutdown Mode, regardless of the classification and detection status.

Writing a “1” at that PWONn bit location turns ON the corresponding port, while writing a “1” at POFFn location turns it off.

---

#### NOTE

1. Writing a “1” at POFFn and PWONn of same port during the same write operation turns the port off.
  2.  $t_{\text{CUT}}$ ,  $t_{\text{START}}$  and disconnect events are priority over the power on command. During  $t_{\text{CUT}}$  or  $t_{\text{START}}$  cool down cycle, any port turn on using Power Enable Command will be ignored and the port will be kept off.
- 

Turning OFF a port with this command also clears the corresponding bits in Detection Event Register (CLSCn, DETCn), Fault Event Register (DISFn, ICUTn), Start Event Register (STRTn), Port n Status Register (Class Pn, Detect Pn) and Detect/Class Enable Register (CLEn, DETEn).

The corresponding PGCn and PECn Bits of Power Event Register will also be set if there is a change.

---

#### NOTE

Note that following a port turn off, it is required to wait at least 2 ms before enabling detection or classification for this port.

---

## Reset Register Command = 1Ah With 1 Data Byte, Write Only

BITS	D7	D6	D5	D4	D3	D2	D1	D0
BIT NAME	CLRAIN	CLINP	-	RESAL	RESP4	RESP3	RESP2	RESP1
RESET OR POR VALUE	0	0	0	0	0	0	0	0

### Bit Descriptions

Writing a “1” at a bit location triggers an event while a “0” has no impact.

**CLRAIN:** Clear all interrupts bit. Writing a “1” to CLRAIN clears all event registers and all bits in the Interrupt Register. It also releases the  $\overline{\text{INT}}$  pin.

**CLINP:** When set, it releases the  $\overline{\text{INT}}$  pin without any impact on the Event Registers nor on the Interrupt Register.

**RESAL:** Reset all bits when RESAL is set. Results in a state equivalent to a power-up reset, including a reread of the Auto pin. Note that the VDUV and VEUV Bits (Supply Event Register) follow the state of VDD and VEE supply rails. Also OSCF (Supply Event Register) will become set regardless of its prior state.

**RESP4-RESP1:** Reset Port Bits. Used to force an immediate port(s) turn off in any mode, by writing a “1” at the corresponding RESPn bit location(s).

Turning OFF a port with this command also clears the corresponding bits in Detection Event Register (CLSCn, DETCn), Fault EVENT Register (DISFn, ICUTn), Start Event Register (STRTn), Port n Status Register (Class Pn, Detect Pn) and DETect/Class Enable Register (CLEN, DETEn).

The corresponding PGCn and PECn Bits of POWER EVENT register will also be set if there is a change.

### NOTE

Following a port reset or Reset all, it is required to wait at least 2 ms before enabling detection or classification for this port.

**ID Register**  
**Command = 1Bh With 1 Data Byte, Read Only**

BITS	D7	D6	D5	D4	D3	D2	D1	D0
BIT NAME	MFR ID					ICV		

**Bit Descriptions**

**MFR ID:** Manufacture Identification number (0110)

**ICV:** Device version number (100)

**ICUT21 Configuration Register**  
**Command = 2Ah With 1 Data Byte, R/W**

BITS	D7	D6	D5	D4	D3	D2	D1	D0
BIT NAME	-	ICUT P2			-	ICUT P1		
RESET OR POR VALUE	0	0	0	0	0	0	0	0

**ICUT43 Configuration Register**  
**Command = 2Bh With 1 Data Byte, R/W**

BITS	D7	D6	D5	D4	D3	D2	D1	D0
BIT NAME	-	ICUT P4			-	ICUT P3		
RESET OR POR VALUE	0	0	0	0	0	0	0	0

**Bit Descriptions**

Defines the  $I_{CUT}$  threshold as following:

**Table 10. ICUT Threshold**

	ICUT Pn		$I_{CUT}$ (mA) if 0.5 $\Omega$ $R_{SENSE}$
0	0	0	374
0	0	1	110
0	1	0	204
0	1	1	374
1	0	0	754 <sup>(1)</sup>
1	0	1	592 <sup>(1)</sup>
1	1	0	686 <sup>(1)</sup>
1	1	1	816 <sup>(1)</sup>

- (1) If ICUT Pn is defined from 100 to 111 inclusively, the port 2X mode bit of High Power and Sine Disable Register must be set, in order to make sure that  $I_{LIM} > I_{CUT}$ . If  $I_{LIM}$  is programmed lower than  $I_{CUT}$ , the  $I_{CUT}$  will not be activated in certain fault situations and damage to the power MOSFET or the load will likely occur.

**Port 1 Current Register****Command = 30h With 2 Data Byte (LSByte first, MSByte second), Read Only**

LSB								
BITS	D7	D6	D5	D4	D3	D2	D1	D0
BIT NAME	I1_7	I1_6	I1_5	I1_4	I1_3	I1_2	I1_1	I1_0
RESET OR POR VALUE	0	0	0	0	0	0	0	0
MSB								
BITS	D7	D6	D5	D4	D3	D2	D1	D0
BIT NAME	-	-	I1_13	I1_12	I1_11	I1_10	I1_9	I1_8
RESET OR POR VALUE	0	0	0	0	0	0	0	0

**Port 2 Current Register****Command = 34h With 2 Data Byte (LSByte first, MSByte second), Read Only**

LSB								
BITS	D7	D6	D5	D4	D3	D2	D1	D0
BIT NAME	I2_7	I2_6	I2_5	I2_4	I2_3	I2_2	I2_1	I2_0
RESET OR POR VALUE	0	0	0	0	0	0	0	0
MSB								
BITS	D7	D6	D5	D4	D3	D2	D1	D0
BIT NAME	-	-	I2_13	I2_12	I2_11	I2_10	I2_9	I2_8
RESET OR POR VALUE	0	0	0	0	0	0	0	0

**Port 3 Current Register**  
**Command = 38h With 2 Data Byte (LSByte first, MSByte second), Read Only**

LSB								
BITS	D7	D6	D5	D4	D3	D2	D1	D0
BIT NAME	I3_7	I3_6	I3_5	I3_4	I3_3	I3_2	I3_1	I3_0
RESET OR POR VALUE	0	0	0	0	0	0	0	0
MSB								
BITS	D7	D6	D5	D4	D3	D2	D1	D0
BIT NAME	-	-	I3_13	I3_12	I3_11	I3_10	I3_9	I3_8
RESET OR POR VALUE	0	0	0	0	0	0	0	0

**Port 4 Current Register**  
**Command = 3Ch With 2 Data Byte (LSByte first, MSByte second), Read Only**

LSB								
BITS	D7	D6	D5	D4	D3	D2	D1	D0
BIT NAME	I4_7	I4_6	I4_5	I4_4	I4_3	I4_2	I4_1	I4_0
RESET OR POR VALUE	0	0	0	0	0	0	0	0
MSB								
BITS	D7	D6	D5	D4	D3	D2	D1	D0
BIT NAME	-	-	I4_13	I4_12	I4_11	I4_10	I4_9	I4_8
RESET OR POR VALUE	0	0	0	0	0	0	0	0

**Bit Descriptions**

Data conversion result. The I<sup>2</sup>C data transmission is a 2-byte transfer.

**NOTE**

The conversion is done using a TI proprietary multi-slope integrating converter.

**In\_13- In\_0:** 14-bit data conversion result of current for port n. The result varies depending on the operating mode.

The equation defining the current measured is:

$$I = N \times I_{STEP} \quad (6)$$

Where I<sub>STEP</sub> is defined below as well as the full scale value, according to the operating mode:

**Table 11. ISTEP Definition<sup>(1)</sup>**

MODE	FULL SCALE VALUE	ISTEP_14 BITS
Port Powered	1 A (with 0.5 Ω R <sub>SENSE</sub> )	61.035 μA
Classification	100 mA (with 0.5 Ω R <sub>SENSE</sub> )	6.1035 μA

(1) The content of the Port n Current Register is not updated when the port is off.

Any port reading should be qualified with the PGn bit of the Power Status Register (10h). If the port bit is a 1, then the reading should be accepted. If zero, the A/D reading should be considered corrupt as it may represent a port that experienced a power fault event or was disabled midway through a conversion.

**Port 1 Voltage Register****Command = 32h With 2 Data Byte (LSByte first, MSByte second), Read Only**

LSB								
BITS	D7	D6	D5	D4	D3	D2	D1	D0
BIT NAME	V1_7	V1_6	V1_5	V1_4	V1_3	V1_2	V1_1	V1_0
RESET OR POR VALUE	0	0	0	0	0	0	0	0
MSB								
BITS	D7	D6	D5	D4	D3	D2	D1	D0
BIT NAME	-	-	V1_13	V1_12	V1_11	V1_10	V1_9	V1_8
RESET OR POR VALUE	0	0	0	0	0	0	0	0

**Port 2 Voltage Register****Command = 36h With 2 Data Byte (LSByte first, MSByte second), Read Only**

LSB								
BITS	D7	D6	D5	D4	D3	D2	D1	D0
BIT NAME	V2_7	V2_6	V2_5	V2_4	V2_3	V2_2	V2_1	V2_0
RESET OR POR VALUE	0	0	0	0	0	0	0	0
MSB								
BITS	D7	D6	D5	D4	D3	D2	D1	D0
BIT NAME	-	-	V2_13	V2_12	V2_11	V2_10	V2_9	V2_8
RESET OR POR VALUE	0	0	0	0	0	0	0	0

**Port 3 Voltage Register**  
**Command = 3Ah With 2 Data Byte (LSByte first, MSByte second), Read Only**

LSB								
BITS	D7	D6	D5	D4	D3	D2	D1	D0
BIT NAME	V3_7	V3_6	V3_5	V3_4	V3_3	V3_2	V3_1	V3_0
RESET OR POR VALUE	0	0	0	0	0	0	0	0
MSB								
BITS	D7	D6	D5	D4	D3	D2	D1	D0
BIT NAME	-	-	V3_13	V3_12	V3_11	V3_10	V3_9	V3_8
RESET OR POR VALUE	0	0	0	0	0	0	0	0

**Port 4 Voltage Register**  
**Command = 3Eh With 2 Data Byte (LSByte first, MSByte second), Read Only**

LSB								
BITS	D7	D6	D5	D4	D3	D2	D1	D0
BIT NAME	V4_7	V4_6	V4_5	V4_4	V4_3	V4_2	V4_1	V4_0
RESET OR POR VALUE	0	0	0	0	0	0	0	0
MSB								
BITS	D7	D6	D5	D4	D3	D2	D1	D0
BIT NAME	-	-	V4_13	V4_12	V4_11	V4_10	V4_9	V4_8
RESET OR POR VALUE	0	0	0	0	0	0	0	0

**Bit Descriptions**

Data conversion result. The I<sup>2</sup>C data transmission is a 2-byte transfer.

**V<sub>n\_13</sub>- V<sub>n\_0</sub>**: 14-bit data conversion result of voltage for port n.

The equation defining the current measured is:

$$V = N \times V_{\text{STEP}} \quad (7)$$

Where  $V_{\text{STEP}}$  is defined below as well as the full scale value:

**Table 12. VSTEP Definition<sup>(1)(2)</sup>**

MODE	FULL SCALE VALUE	V <sub>STEP</sub> 14 BITS
Port Powered	97 V	5.920 mV

(1) A powered port voltage measurement is made between OUT<sub>n</sub> and AGND.

(2) The content of the Port n Voltage Register is not updated when the port is off.

Any port reading should be qualified with the PG<sub>n</sub> bit of the Power Status Register (10h). If the port bit is a 1, then the reading should be accepted. If zero, the A/D reading should be considered corrupt as it may represent a port that experienced a power fault event or was disabled midway through a conversion.

### High Power and Sine Disable Register Command = 40h With 1 Data Byte, R/W

BITS	D7	D6	D5	D4	D3	D2	D1	D0
BIT NAME	HPW4	HPW3	HPW2	HPW1	SNDI	-	-	-
RESET OR POR VALUE	0	0	0	0	0	-	-	-

#### Bit Descriptions

**HPW4- HPW1:** When set, this activates the high power (2X) mode for a port which increases its  $I_{LIM}$  and  $I_{SHORT}$  levels to around two times its normal settings. In any of these modes, the  $I_{CUT}$  timer still starts when the  $I_{CUT}$  threshold is exceeded.

#### NOTE

1. If  $I_{CUT} P_n$  (see ICUTxx Configuration Register) is defined from 100 to 111 inclusively, the port 2X mode bit of High Power and Sine Disable Register must be set, in order to make sure that  $I_{LIM} > I_{CUT}$ . If  $I_{LIM}$  is programmed lower than  $I_{CUT}$ , the  $I_{CUT}$  will not be activated in certain fault situations and damage to the power MOSFET or the load will likely occur.
2. A linear foldback mechanism measures the port voltage across AGND and OUTn to reduce the current limit threshold from 100% at 18 V (28 V if in 2X mode) down to around 14% at a port voltage of 0 V.

**SNDI:** When set, this deactivates the internal sinewave generator used for AC disconnect function. If AC disconnect is used, this bit should always be maintained to 0.

#### NOTE

Manually setting and resetting SNDI clears the OSCF bit of the Supply Event Register.

### Firmware Revision Register Command = 41h With 1 Data Byte, Read Only

BITS	D7	D6	D5	D4	D3	D2	D1	D0
BIT NAME	-	-	-	-	-	FRV		

#### Bit Descriptions

**FRV:** Firmware revision number

**I<sup>2</sup>C Watchdog Register**  
**Command = 42h With 1 Data Byte, R/W**

BITS	D7	D6	D5	D4	D3	D2	D1	D0
BIT NAME	-	-	-	IWDD3	IWDD2	IWDD1	IWDD0	WDS
RESET OR POR VALUE	-	-	-	1	0	1	1	0

**Bit Descriptions**

The I<sup>2</sup>C watchdog timer monitors the I<sup>2</sup>C clock line in order to prevent hung software situations that could leave ports in a hazardous state. The timer can be reset by either edge on SCL input. If the watchdog timer expires, all ports will be turned off and WDS bit will be set. The nominal watchdog time-out period is 2 seconds.

**IWD3- IWD0:** I<sup>2</sup>C watchdog disable. When equal to 1011b, the watchdog is masked. Otherwise, it is unmasked and the watchdog is operational.

**WDS:** I<sup>2</sup>C Watchdog Timer Status, valid even if the watchdog is masked. When set, it means that the watchdog timer has expired without any activity on I<sup>2</sup>C clock line. Writing 0 at WDS location clears it. Note that when the watchdog timer expires, all ports are also turned off.

**Device ID Register**  
**Command = 43h With 1 Data Byte, R/W**

BITS	D7	D6	D5	D4	D3	D2	D1	D0
BIT NAME	DID		-	-	SR			

**Bit Descriptions**

**DID:** device ID number (101)

**SR:** Silicon revision number

---

**NOTE**

This is a R/W register. The initial state after power up can be modified by writing to this register.

---

## Test Enable Register

### Command = 1Dh With 1 Data Byte, R/W

BITS	D7	D6	D5	D4	D3	D2	D1	D0
BIT NAME	UNLOCK CODE							
RESET OR POR VALUE	0	0	0	0	0	0	0	0

### Bit Descriptions

**Unlock Code:** Gives access to the Multiplexed Shutdown Configuration Register.

BCh = Unlocks the access to Multiplexed Shutdown Configuration Register Any value else than

BCh = Locks the access to Multiplexed Shutdown Configuration Register.

---

### NOTE

- At power up, the Multiplexed Shutdown Configuration Register is locked. Unlocking the access to this register also gives access to special test modes registers as well as the internal microprocessor's working memory which must not be used in the application. In order to prevent any accidental write operation, it is highly recommended to keep the Multiplexed Shutdown Configuration Register locked in any circumstance except during the time when it needs to be reconfigured. Once the multiplexed shutdown has been reconfigured, it is highly recommended to lock the access to it by writing any value else than BCh in the Test Enable Register.
  - Once the lock code has been written once into the Test Enable Register, the procedure to reprogram the Multiplexed Shutdown Configuration Register is:
    - Write BCh into Test Enable Register: unlock code
    - The I<sup>2</sup>C device address becomes 20h until the next lock code
    - Write the configuration byte in Multiplexed Shutdown Configuration Register
    - Write 00h into Test Enable Register: lock code, still with device address equal to 20h
    - After that operation, the I<sup>2</sup>C device address stops being equal to 20h and becomes again defined using the address pins, as described in the Pin Status Register
-

## Multiplexed Shutdown Configuration Register

Command = 22h With 1 Data Byte, R/W

BITS	D7	D6	D5	D4	D3	D2	D1	D0
BIT NAME	-	-	-	MSE	MSE4	MSE3	MSE2	MSE1
RESET OR POR VALUE	-	-	-	0	0	0	0	0

### Bit Descriptions

Used to quickly turn off ports using the  $\overline{\text{SHDN1\_A}}$  pin.

**MSE:** Multiplexed Shutdown Enable bit. Used to quickly turn off ports using the  $\overline{\text{SHDN1\_A}}$  pin.

- 1 =  $\overline{\text{SHDN1\_A}}$  pin can quickly turn off active port(s) having the corresponding bit(s) in Multiplexed Shutdown Configuration Register being set.
- 0 =  $\overline{\text{SHDN1\_A}}$  pin has no impact on the status of output ports 2 to 4. The pin can turn off port 1 only.

---

#### NOTE

If the Multiplexed Shutdown Function is enabled, the  $\overline{\text{SHDN2}}$  to  $\overline{\text{SHDN4}}$  inputs must be at logic high.

---

**MSE1-4:** Used to quickly turn off ports using the  $\overline{\text{SHDN1\_A}}$  pin, if MSE bit of Multiplexed Shutdown Enable Register is set. Each bit corresponds to one particular port. If MSE bit of Multiplexed Shutdown Enable Register is set:

- 1 =  $\overline{\text{SHDN1\_A}}$  going low pin will quickly turn off the port.
- 0 =  $\overline{\text{SHDN1\_A}}$  pin has no impact on the port.

---

#### NOTE

In order to have access to the Multiplexed Shutdown Configuration Register, refer to the Test Enable Register.

---

## REVISION HISTORY

<b>Changes from Original (September 2010) to Revision A</b>	<b>Page</b>
• Added Slew rate to the RECOMMENDED OPERATING CONDITIONS table .....	3
• Changed the DESCRIPTION of Pin 16 (VDD) .....	10
• Changed the DESCRIPTION of Pins 32, 29, 25 (SEN1-3) .....	10
• Changed the DESCRIPTION of Pin 22 (SEN4) .....	10
• Changed the DESCRIPTION of Pins 33, 30, 26, 23 (GAT1-4) .....	10
• Changed the DESCRIPTION of Pins 34, 31, 27, 24 (OUT1-4) .....	10
• Changed the DESCRIPTION of Pin 28 (VEE) .....	10
• Changed <a href="#">Figure 14</a> .....	15
• Changed 1 $\mu$ F to 0.1 $\mu$ F in <a href="#">Figure 23</a> .....	18
• Changed 1 $\mu$ F to 0.1 $\mu$ F in <a href="#">Figure 32</a> .....	26
<b>Changes from Revision A (May 2013) to Revision B</b>	
• Changed $t_{ED}$ - Error delay timing From: MAX = 750 ms To: MIN = 750 ms .....	7

**PACKAGING INFORMATION**

Orderable Device	Status (1)	Package Type	Package Drawing	Pins	Package Qty	Eco Plan (2)	Lead/Ball Finish (6)	MSL Peak Temp (3)	Op Temp (°C)	Device Marking (4/5)	Samples
TPS23851DCE	LIFEBUY	SSOP	DCE	36	25	Green (RoHS & no Sb/Br)	CU NIPDAU	Level-3-260C-168 HR	-20 to 125	TPS23851	
TPS23851DCER	LIFEBUY	SSOP	DCE	36	1000	Green (RoHS & no Sb/Br)	CU NIPDAU	Level-3-260C-168 HR	-20 to 125	TPS23851	

(1) The marketing status values are defined as follows:

**ACTIVE:** Product device recommended for new designs.

**LIFEBUY:** TI has announced that the device will be discontinued, and a lifetime-buy period is in effect.

**NRND:** Not recommended for new designs. Device is in production to support existing customers, but TI does not recommend using this part in a new design.

**PREVIEW:** Device has been announced but is not in production. Samples may or may not be available.

**OBSOLETE:** TI has discontinued the production of the device.

(2) Eco Plan - The planned eco-friendly classification: Pb-Free (RoHS), Pb-Free (RoHS Exempt), or Green (RoHS & no Sb/Br) - please check <http://www.ti.com/productcontent> for the latest availability information and additional product content details.

**TBD:** The Pb-Free/Green conversion plan has not been defined.

**Pb-Free (RoHS):** TI's terms "Lead-Free" or "Pb-Free" mean semiconductor products that are compatible with the current RoHS requirements for all 6 substances, including the requirement that lead not exceed 0.1% by weight in homogeneous materials. Where designed to be soldered at high temperatures, TI Pb-Free products are suitable for use in specified lead-free processes.

**Pb-Free (RoHS Exempt):** This component has a RoHS exemption for either 1) lead-based flip-chip solder bumps used between the die and package, or 2) lead-based die adhesive used between the die and leadframe. The component is otherwise considered Pb-Free (RoHS compatible) as defined above.

**Green (RoHS & no Sb/Br):** TI defines "Green" to mean Pb-Free (RoHS compatible), and free of Bromine (Br) and Antimony (Sb) based flame retardants (Br or Sb do not exceed 0.1% by weight in homogeneous material)

(3) MSL, Peak Temp. - The Moisture Sensitivity Level rating according to the JEDEC industry standard classifications, and peak solder temperature.

(4) There may be additional marking, which relates to the logo, the lot trace code information, or the environmental category on the device.

(5) Multiple Device Markings will be inside parentheses. Only one Device Marking contained in parentheses and separated by a "~" will appear on a device. If a line is indented then it is a continuation of the previous line and the two combined represent the entire Device Marking for that device.

(6) Lead/Ball Finish - Orderable Devices may have multiple material finish options. Finish options are separated by a vertical ruled line. Lead/Ball Finish values may wrap to two lines if the finish value exceeds the maximum column width.

**Important Information and Disclaimer:** The information provided on this page represents TI's knowledge and belief as of the date that it is provided. TI bases its knowledge and belief on information provided by third parties, and makes no representation or warranty as to the accuracy of such information. Efforts are underway to better integrate information from third parties. TI has taken and continues to take reasonable steps to provide representative and accurate information but may not have conducted destructive testing or chemical analysis on incoming materials and chemicals. TI and TI suppliers consider certain information to be proprietary, and thus CAS numbers and other limited information may not be available for release.

In no event shall TI's liability arising out of such information exceed the total purchase price of the TI part(s) at issue in this document sold by TI to Customer on an annual basis.

## TAPE AND REEL INFORMATION



### QUADRANT ASSIGNMENTS FOR PIN 1 ORIENTATION IN TAPE



\*All dimensions are nominal

Device	Package Type	Package Drawing	Pins	SPQ	Reel Diameter (mm)	Reel Width W1 (mm)	A0 (mm)	B0 (mm)	K0 (mm)	P1 (mm)	W (mm)	Pin1 Quadrant
TPS23851DCER	SSOP	DCE	36	1000	330.0	24.4	10.75	15.7	2.7	12.0	24.0	Q1

**TAPE AND REEL BOX DIMENSIONS**

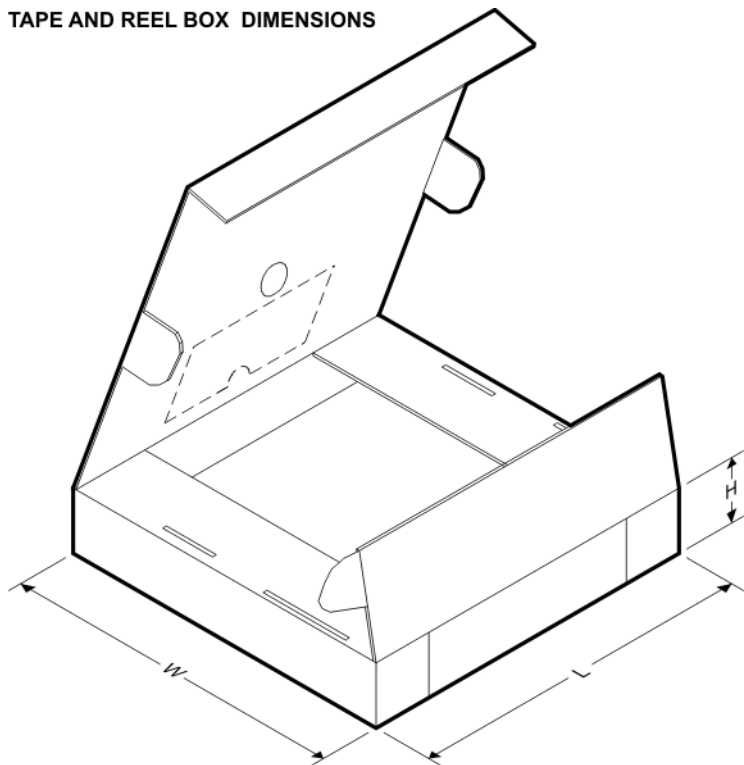

\*All dimensions are nominal

Device	Package Type	Package Drawing	Pins	SPQ	Length (mm)	Width (mm)	Height (mm)
TPS23851DCER	SSOP	DCE	36	1000	367.0	367.0	45.0

DCE (R-PDSO-G\*\*) 36 PINS SHOWN

PLASTIC SMALL-OUTLINE

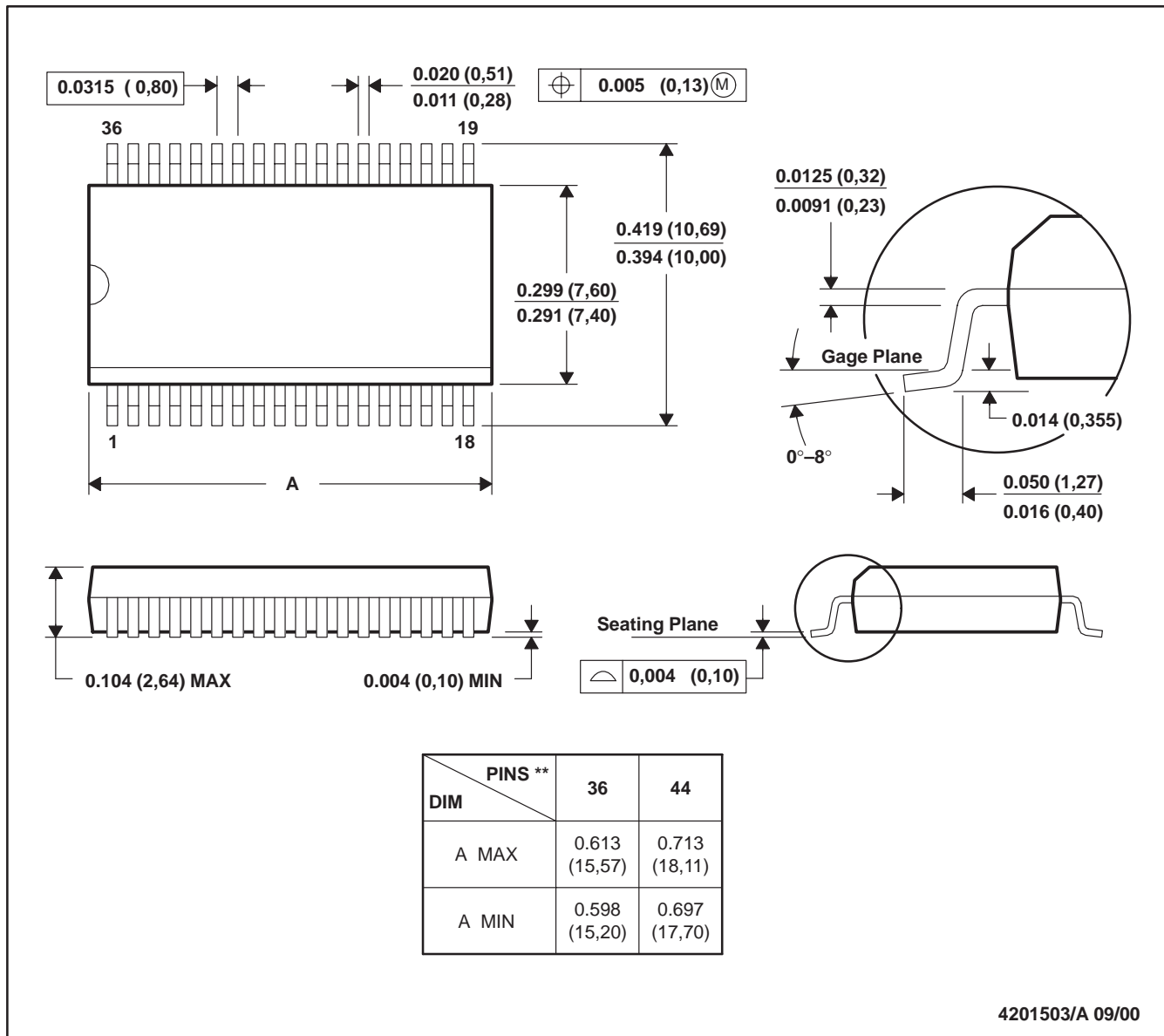

- NOTES: A. All linear dimensions are in millimeters.  
 B. This drawing is subject to change without notice.  
 C. Body dimensions do not include mold flash or protrusion not to exceed 0.006 (0,15).

## IMPORTANT NOTICE

Texas Instruments Incorporated and its subsidiaries (TI) reserve the right to make corrections, enhancements, improvements and other changes to its semiconductor products and services per JESD46, latest issue, and to discontinue any product or service per JESD48, latest issue. Buyers should obtain the latest relevant information before placing orders and should verify that such information is current and complete. All semiconductor products (also referred to herein as "components") are sold subject to TI's terms and conditions of sale supplied at the time of order acknowledgment.

TI warrants performance of its components to the specifications applicable at the time of sale, in accordance with the warranty in TI's terms and conditions of sale of semiconductor products. Testing and other quality control techniques are used to the extent TI deems necessary to support this warranty. Except where mandated by applicable law, testing of all parameters of each component is not necessarily performed.

TI assumes no liability for applications assistance or the design of Buyers' products. Buyers are responsible for their products and applications using TI components. To minimize the risks associated with Buyers' products and applications, Buyers should provide adequate design and operating safeguards.

TI does not warrant or represent that any license, either express or implied, is granted under any patent right, copyright, mask work right, or other intellectual property right relating to any combination, machine, or process in which TI components or services are used. Information published by TI regarding third-party products or services does not constitute a license to use such products or services or a warranty or endorsement thereof. Use of such information may require a license from a third party under the patents or other intellectual property of the third party, or a license from TI under the patents or other intellectual property of TI.

Reproduction of significant portions of TI information in TI data books or data sheets is permissible only if reproduction is without alteration and is accompanied by all associated warranties, conditions, limitations, and notices. TI is not responsible or liable for such altered documentation. Information of third parties may be subject to additional restrictions.

Resale of TI components or services with statements different from or beyond the parameters stated by TI for that component or service voids all express and any implied warranties for the associated TI component or service and is an unfair and deceptive business practice. TI is not responsible or liable for any such statements.

Buyer acknowledges and agrees that it is solely responsible for compliance with all legal, regulatory and safety-related requirements concerning its products, and any use of TI components in its applications, notwithstanding any applications-related information or support that may be provided by TI. Buyer represents and agrees that it has all the necessary expertise to create and implement safeguards which anticipate dangerous consequences of failures, monitor failures and their consequences, lessen the likelihood of failures that might cause harm and take appropriate remedial actions. Buyer will fully indemnify TI and its representatives against any damages arising out of the use of any TI components in safety-critical applications.

In some cases, TI components may be promoted specifically to facilitate safety-related applications. With such components, TI's goal is to help enable customers to design and create their own end-product solutions that meet applicable functional safety standards and requirements. Nonetheless, such components are subject to these terms.

No TI components are authorized for use in FDA Class III (or similar life-critical medical equipment) unless authorized officers of the parties have executed a special agreement specifically governing such use.

Only those TI components which TI has specifically designated as military grade or "enhanced plastic" are designed and intended for use in military/aerospace applications or environments. Buyer acknowledges and agrees that any military or aerospace use of TI components which have **not** been so designated is solely at the Buyer's risk, and that Buyer is solely responsible for compliance with all legal and regulatory requirements in connection with such use.

TI has specifically designated certain components as meeting ISO/TS16949 requirements, mainly for automotive use. In any case of use of non-designated products, TI will not be responsible for any failure to meet ISO/TS16949.

### Products

Audio	<a href="http://www.ti.com/audio">www.ti.com/audio</a>
Amplifiers	<a href="http://amplifier.ti.com">amplifier.ti.com</a>
Data Converters	<a href="http://dataconverter.ti.com">dataconverter.ti.com</a>
DLP® Products	<a href="http://www.dlp.com">www.dlp.com</a>
DSP	<a href="http://dsp.ti.com">dsp.ti.com</a>
Clocks and Timers	<a href="http://www.ti.com/clocks">www.ti.com/clocks</a>
Interface	<a href="http://interface.ti.com">interface.ti.com</a>
Logic	<a href="http://logic.ti.com">logic.ti.com</a>
Power Mgmt	<a href="http://power.ti.com">power.ti.com</a>
Microcontrollers	<a href="http://microcontroller.ti.com">microcontroller.ti.com</a>
RFID	<a href="http://www.ti-rfid.com">www.ti-rfid.com</a>
OMAP Applications Processors	<a href="http://www.ti.com/omap">www.ti.com/omap</a>
Wireless Connectivity	<a href="http://www.ti.com/wirelessconnectivity">www.ti.com/wirelessconnectivity</a>

### Applications

Automotive and Transportation	<a href="http://www.ti.com/automotive">www.ti.com/automotive</a>
Communications and Telecom	<a href="http://www.ti.com/communications">www.ti.com/communications</a>
Computers and Peripherals	<a href="http://www.ti.com/computers">www.ti.com/computers</a>
Consumer Electronics	<a href="http://www.ti.com/consumer-apps">www.ti.com/consumer-apps</a>
Energy and Lighting	<a href="http://www.ti.com/energy">www.ti.com/energy</a>
Industrial	<a href="http://www.ti.com/industrial">www.ti.com/industrial</a>
Medical	<a href="http://www.ti.com/medical">www.ti.com/medical</a>
Security	<a href="http://www.ti.com/security">www.ti.com/security</a>
Space, Avionics and Defense	<a href="http://www.ti.com/space-avionics-defense">www.ti.com/space-avionics-defense</a>
Video and Imaging	<a href="http://www.ti.com/video">www.ti.com/video</a>

### TI E2E Community

[e2e.ti.com](http://e2e.ti.com)

## Looking for pricing, stock, or lifecycle information?

Click below to explore more details on WIN SOURCE:

 [View TPS23851DCE](#) on WIN SOURCE

 [Texas Instruments](#) Information

## Optimize Your Supply Chain with WIN SOURCE Solutions

-  Global Sourcing Solution
-  Obsolete Management
-  Cost Control Management
-  Shortage Management
-  Alternative Solution
-  Excess Inventory Management