



**THE DATASHEET OF
LM5113TME/NOPB**



LM5113 80-V, 1.2-A, 5-A, Half Bridge GaN Driver

1 Features

- Independent high-side and low-side TTL logic inputs
- 1.2 A / 5 A peak source/sink current
- High-side floating bias voltage rail Operates up to 100 VDC
- Internal bootstrap supply voltage clamping
- Split outputs for adjustable turnon/turnoff strength
- 0.6-Ω / 2.1-Ω pulldown/pullup resistance
- Fast propagation times (28 ns typical)
- Excellent propagation delay matching (1.5 ns typical)
- Supply rail undervoltage lockout
- Low power consumption

2 Applications

- [Merchant telecom rectifiers](#)
- [Merchant DC/DC](#)
- [Closed loop stepper motor drive](#)
- [Baseband unit \(BBU\)](#)
- [Macro remote radio unit \(RRU\)](#)

3 Description

The LM5113 device is designed to drive both the high-side and the low-side enhancement mode Gallium Nitride (GaN) FETs in a synchronous buck or a half bridge configuration. The floating high-side driver is capable of driving a high-side enhancement mode GaN FET operating up to 100 V. The high-side bias voltage is generated using a bootstrap technique and is internally clamped at 5.2 V, which prevents the gate voltage from exceeding the maximum gate-source voltage rating of enhancement mode GaN FETs. The inputs of the LM5113 are TTL logic compatible, and can withstand input voltages up to 14 V regardless of the VDD voltage. The LM5113 has split gate outputs, providing flexibility to adjust the turnon and turnoff strength independently.

The LMG1205 is an enhancement over the LM5113. The LMG1205 takes the design of the LM5113 and includes start-up logic, level shifter, and power-off Vgs clamp enhancements to provide a more robust solution.

In addition, the strong sink capability of the LM5113 maintains the gate in the low state, preventing unintended turnon during switching. The LM5113 can operate up to several MHz. The LM5113 is available in a standard WSON-10 pin package and a 12-bump DSBGA package. The WSON-10 pin package contains an exposed pad to aid power dissipation. The DSBGA package offers a compact footprint and minimized package inductance.

Device Information⁽¹⁾

PART NUMBER	PACKAGE	BODY SIZE (NOM)
LM5113	WSON (10)	4.00 mm × 4.00 mm
	DSBGA (12)	2.00 mm × 2.00 mm

(1) For all available packages, see the orderable addendum at the end of the data sheet.

Simplified Application Diagram

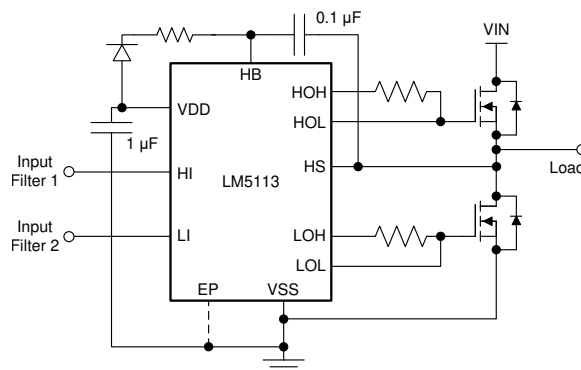

Table of Contents

1 Features	1	7.3 Feature Description.....	11
2 Applications	1	7.4 Device Functional Modes.....	13
3 Description	1	8 Application and Implementation	14
4 Revision History	2	8.1 Application Information.....	14
5 Pin Configuration and Functions	4	8.2 Typical Application	14
6 Specifications	5	9 Power Supply Recommendations	18
6.1 Absolute Maximum Ratings	5	10 Layout	19
6.2 ESD Ratings.....	5	10.1 Layout Guidelines	19
6.3 Recommended Operating Conditions.....	5	10.2 Layout Examples.....	20
6.4 Thermal Information	5	11 Device and Documentation Support	21
6.5 Electrical Characteristics	6	11.1 Documentation Support	21
6.6 Switching Characteristics	7	11.2 Support Resources	21
6.7 Typical Characteristics.....	8	11.3 Trademarks	21
7 Detailed Description	11	11.4 Electrostatic Discharge Caution.....	21
7.1 Overview	11	11.5 Glossary	21
7.2 Functional Block Diagram	11	12 Mechanical, Packaging, and Orderable Information	21

4 Revision History

NOTE: Page numbers for previous revisions may differ from page numbers in the current version.

Changes from Revision H (January 2018) to Revision I	Page
• Removed "NRND" from data sheet title.....	1
• Removed NRND disclosure statement	1

Changes from Revision G (January 2016) to Revision H	Page
• Changed data sheet title from: LM5113 100 V 1.2-A / 5-A, Half-Bridge Gate Driver for Enhancement Mode GaN FETs to: LM5113 80-V, 1.2-A, 5-A, Half Bridge GaN Driver	1
• Added Not Recommended for New Designs statement to the data sheet.....	1
• Added content to the <i>Description</i> section	1
• Changed the first page key graphic	1
• Removed HB to VDD parameter from the <i>Absolute Maximum Ratings</i> table.....	5
• Changed the HS to VSS maximum from: 100 V to: 93 V.....	5
• Changed the HB to VSS maximum from: 107 V to: V(HS) + 7 V.....	5
• Changed the human-body model value from: ±2000 to: ±1000	5
• Changed HS maximum from: 100 V to: 90 V	5
• Changed the <i>Functional Block Diagram</i>	11
• Changed the last paragraph and add new images to the <i>Input and Output</i> section	11
• Added content to the <i>Start-up and UVLO</i> section	12

Changes from Revision F (April 2013) to Revision G	Page
• Added <i>ESD Ratings</i> table, <i>Feature Description</i> section, <i>Device Functional Modes</i> , <i>Application and Implementation</i> section, <i>Power Supply Recommendations</i> section, <i>Layout</i> section, <i>Device and Documentation Support</i> section, and <i>Mechanical, Packaging, and Orderable Information</i> section	1

Changes from Revision E (April 2013) to Revision F**Page**

-
- Changed layout of National Data Sheet to TI format 1
-

5 Pin Configuration and Functions

DPR Package
10-Pin WSON With Exposed Thermal Pad
Top View

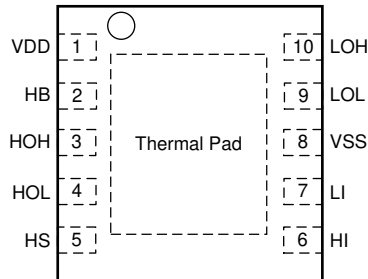

YFX Package
12-Pin DSBGA
Top View

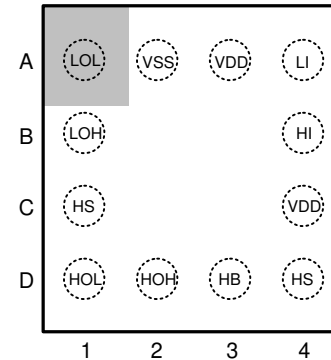

Pin Functions

NAME	PIN		TYPE ⁽¹⁾	DESCRIPTION
	WSON	DSBGA		
VDD	1	A3, C4 ⁽²⁾	P	5-V Positive gate drive supply: locally decouple to VSS using low ESR/ESL capacitor located as close to the IC as possible.
HB	2	D3	P	High-side gate driver bootstrap rail: connect the positive terminal of the bootstrap capacitor to HB and the negative terminal to HS. The bootstrap capacitor should be placed as close to the IC as possible.
HOH	3	D2	O	High-side gate driver turnon output: connect to the gate of high-side GaN FET with a short, low inductance path. A gate resistor can be used to adjust the turnon speed.
HOL	4	D1	O	High-side gate driver turnoff output: connect to the gate of high-side GaN FET with a short, low inductance path. A gate resistor can be used to adjust the turnoff speed.
HS	5	C1, D4 ⁽²⁾	P	High-side GaN FET source connection: connect to the bootstrap capacitor negative terminal and the source of the high-side GaN FET.
HI	6	B4	I	High-side driver control input. The LM5113 inputs have TTL type thresholds. Unused inputs should be tied to ground and not left open.
LI	7	A4	I	Low-side driver control input. The LM5113 inputs have TTL type thresholds. Unused inputs should be tied to ground and not left open.
VSS	8	A2	G	Ground return: all signals are referenced to this ground.
LOL	9	A1	O	Low-side gate driver sink-current output: connect to the gate of the low-side GaN FET with a short, low inductance path. A gate resistor can be used to adjust the turnoff speed.
LOH	10	B1	O	Low-side gate driver source-current output: connect to the gate of high-side GaN FET with a short, low inductance path. A gate resistor can be used to adjust the turnon speed.
Exposed Pad	EP	—	—	Exposed pad: TI recommends that the exposed pad on the bottom of the package be soldered to ground plane on the printed-circuit board to aid thermal dissipation.

(1) I = Input, O = Output, G = Ground, P = Power

(2) A3 and C4, C1 and D4 are internally connected

6 Specifications

6.1 Absolute Maximum Ratings

over operating free-air temperature range (unless otherwise noted)⁽¹⁾

	MIN	MAX	UNIT
VDD to VSS	-0.3	7	V
HB to HS	-0.3	7	V
LI or HI input	-0.3	15	V
LOH, LOL output	-0.3	VDD + 0.3	V
HOH, HOL output	$V_{HS} - 0.3$	$V_{HB} + 0.3$	V
HS to VSS	-5	93	V
HB to VSS	0	$V_{HS} + 7$	V
Operating junction temperature		150	°C
Storage temperature, T_{stg}	-55	150	°C

- (1) Stresses beyond those listed under *Absolute Maximum Ratings* may cause permanent damage to the device. These are stress ratings only, which do not imply functional operation of the device at these or any other conditions beyond those indicated under *Recommended Operating Conditions*. Exposure to absolute-maximum-rated conditions for extended periods may affect device reliability.

6.2 ESD Ratings

		VALUE	UNIT
$V_{(ESD)}$ Electrostatic discharge	Human-body model (HBM), per ANSI/ESDA/JEDEC JS-001 ⁽¹⁾	±2000	V
	Charged-device model (CDM), per JEDEC specification JESD22-C101 ⁽²⁾	±1000	

- (1) JEDEC document JEP155 states that 500-V HBM allows safe manufacturing with a standard ESD control process.
(2) JEDEC document JEP157 states that 250-V CDM allows safe manufacturing with a standard ESD control process.

6.3 Recommended Operating Conditions

over operating free-air temperature range (unless otherwise noted)

	MIN	NOM	MAX	UNIT
VDD	4.5		5.5	V
LI or HI input	0		14	V
HS	-5		90	V
HB	$V_{HS} + 4$		$V_{HS} + 5.5$	V
HS slew rate			50	V/ns
Operating junction temperature	-40		125	°C

6.4 Thermal Information

THERMAL METRIC ⁽¹⁾		LM5113		UNIT
		DPR (WSON)	YFX (DSBGA)	
		10 PINS	12 PINS	
$R_{\theta JA}$	Junction-to-ambient thermal resistance	37.5	76.8	°C/W
$R_{\theta JC(top)}$	Junction-to-case (top) thermal resistance	35.8	0.6	°C/W
$R_{\theta JB}$	Junction-to-board thermal resistance	14.7	12.0	°C/W
ψ_{JT}	Junction-to-top characterization parameter	0.3	1.6	°C/W
ψ_{JB}	Junction-to-board characterization parameter	14.9	12.0	°C/W
$R_{\theta JC(bot)}$	Junction-to-case (bottom) thermal resistance	4.1	–	°C/W

- (1) For more information about traditional and new thermal metrics, see the [Semiconductor and IC Package Thermal Metrics](#) application report.

6.5 Electrical Characteristics

Specifications are $T_J = 25^\circ\text{C}$. Unless otherwise specified: $V_{DD} = V_{HB} = 5\text{ V}$, $V_{SS} = V_{HS} = 0\text{ V}$. No load on LOL and HOL or HOH and HOL⁽¹⁾.

PARAMETER		TEST CONDITIONS	MIN	TYP	MAX	UNIT
SUPPLY CURRENTS						
I_{DD}	VDD quiescent current	LI = HI = 0 V	$T_J = 25^\circ\text{C}$	0.07		mA
			$T_J = -40^\circ\text{C to } 125^\circ\text{C}$	0.1		
I_{DDO}	VDD operating current	f = 500 kHz	$T_J = 25^\circ\text{C}$	2.0		mA
			$T_J = -40^\circ\text{C to } 125^\circ\text{C}$	3.0		
I_{HB}	Total HB quiescent current	LI = HI = 0 V	$T_J = 25^\circ\text{C}$	0.08		mA
			$T_J = -40^\circ\text{C to } 125^\circ\text{C}$	0.1		
I_{HBO}	Total HB operating current	f = 500 kHz	$T_J = 25^\circ\text{C}$	1.5		mA
			$T_J = -40^\circ\text{C to } 125^\circ\text{C}$	2.5		
I_{HBS}	HB to VSS quiescent current	HS = HB = 100 V	$T_J = 25^\circ\text{C}$	0.1		μA
			$T_J = -40^\circ\text{C to } 125^\circ\text{C}$	8		
I_{HBSO}	HB to VSS operating current	f = 500 kHz	$T_J = 25^\circ\text{C}$	0.4		mA
			$T_J = -40^\circ\text{C to } 125^\circ\text{C}$	1.0		
INPUT PINS						
V_{IR}	Input voltage threshold	Rising edge	$T_J = 25^\circ\text{C}$	2.06		V
			$T_J = -40^\circ\text{C to } 125^\circ\text{C}$	1.89	2.18	
V_{IF}	Input voltage threshold	Falling edge	$T_J = 25^\circ\text{C}$	1.66		V
			$T_J = -40^\circ\text{C to } 125^\circ\text{C}$	1.48	1.76	
V_{IHYS}	Input voltage hysteresis			400		mV
R_I	Input pulldown resistance	$T_J = 25^\circ\text{C}$		200		k Ω
		$T_J = -40^\circ\text{C to } 125^\circ\text{C}$	100	300		
UNDERVOLTAGE PROTECTION						
V_{DDR}	VDD rising threshold	$T_J = 25^\circ\text{C}$		3.8		V
		$T_J = -40^\circ\text{C to } 125^\circ\text{C}$	3.2	4.5		
V_{DDH}	VDD threshold hysteresis			0.2		V
V_{HBR}	HB rising threshold	$T_J = 25^\circ\text{C}$		3.2		V
		$T_J = -40^\circ\text{C to } 125^\circ\text{C}$	2.5	3.9		
V_{HBH}	HB threshold hysteresis			0.2		V
BOOTSTRAP DIODE						
V_{DL}	Low-current forward voltage	$I_{VDD-HB} = 100\ \mu\text{A}$	$T_J = 25^\circ\text{C}$	0.45		V
			$T_J = -40^\circ\text{C to } 125^\circ\text{C}$		0.65	
V_{DH}	High-current forward voltage	$I_{VDD-HB} = 100\ \text{mA}$	$T_J = 25^\circ\text{C}$	0.90		V
			$T_J = -40^\circ\text{C to } 125^\circ\text{C}$		1.00	
R_D	Dynamic resistance	$I_{VDD-HB} = 100\ \text{mA}$	$T_J = 25^\circ\text{C}$	1.85		Ω
			$T_J = -40^\circ\text{C to } 125^\circ\text{C}$		3.60	
	HB-HS clamp	Regulation voltage	$T_J = 25^\circ\text{C}$	5.2		V
			$T_J = -40^\circ\text{C to } 125^\circ\text{C}$	4.7	5.45	

(1) Minimum and maximum limits are 100% production tested at 25°C . Limits over the operating temperature range are ensured through correlation using Statistical Quality Control (SQC) methods. Limits are used to calculate Average Outgoing Quality Level (AOQL).

Electrical Characteristics (continued)

Specifications are $T_J = 25^\circ\text{C}$. Unless otherwise specified: $V_{DD} = V_{HB} = 5\text{ V}$, $V_{SS} = V_{HS} = 0\text{ V}$. No load on LOL and HOL or HOH and HOL⁽¹⁾.

PARAMETER		TEST CONDITIONS		MIN	TYP	MAX	UNIT
LOW- AND HIGH-SIDE GATE DRIVER							
V_{OL}	Low-level output voltage	$I_{HOL} = I_{LOL} = 100\text{ mA}$	$T_J = 25^\circ\text{C}$	0.06		0.10	V
			$T_J = -40^\circ\text{C to } 125^\circ\text{C}$				
V_{OH}	High-level output voltage $V_{OH} = V_{DD} - LOH$ or $V_{OH} = HB - HOH$	$I_{HOH} = I_{LOH} = 100\text{ mA}$	$T_J = 25^\circ\text{C}$	0.21		0.31	V
			$T_J = -40^\circ\text{C to } 125^\circ\text{C}$				
I_{OHL}	Peak source current	HOH, LOH = 0 V		1.2		A	
I_{OLL}	Peak sink current	HOL, LOL = 5 V		5		A	
I_{OHLK}	High-level output leakage current	HOH, LOH = 0 V	$T_J = -40^\circ\text{C to } 125^\circ\text{C}$	1.5		μA	
I_{OLLK}	Low-level output leakage current	HOL, LOL = 5 V	$T_J = -40^\circ\text{C to } 125^\circ\text{C}$	1.5		μA	

6.6 Switching Characteristics

over operating free-air temperature range (unless otherwise noted)

PARAMETER		TEST CONDITIONS		MIN	TYP	MAX	UNIT
t_{LPHL}	LO turnoff propagation delay	LI falling to LOL falling	$T_J = 25^\circ\text{C}$	26.5		45.0	ns
			$T_J = -40^\circ\text{C to } 125^\circ\text{C}$				
t_{LPLH}	LO turnon propagation delay	LI rising to LOH rising	$T_J = 25^\circ\text{C}$	28.0		45.0	ns
			$T_J = -40^\circ\text{C to } 125^\circ\text{C}$				
t_{HPHL}	HO turnoff propagation delay	HI falling to HOL falling	$T_J = 25^\circ\text{C}$	26.5		45.0	ns
			$T_J = -40^\circ\text{C to } 125^\circ\text{C}$				
t_{HPLH}	HO turnon propagation delay	HI rising to HOH rising	$T_J = 25^\circ\text{C}$	28.0		45.0	ns
			$T_J = -40^\circ\text{C to } 125^\circ\text{C}$				
t_{MON}	Delay matching LO on & HO off	$T_J = 25^\circ\text{C}$		1.5		8.0	ns
		$T_J = -40^\circ\text{C to } 125^\circ\text{C}$					
t_{MOFF}	Delay matching LO off & HO on	$T_J = 25^\circ\text{C}$		1.5		8.0	ns
		$T_J = -40^\circ\text{C to } 125^\circ\text{C}$					
t_{HRC}	HO rise time (0.5 V – 4.5 V)	$C_L = 1000\text{ pF}$		7.0		ns	
t_{LRC}	LO rise time (0.5 V – 4.5 V)	$C_L = 1000\text{ pF}$		7.0		ns	
t_{HFC}	HO fall time (0.5 V – 4.5 V)	$C_L = 1000\text{ pF}$		1.5		ns	
t_{LFC}	LO fall time (0.5 V – 4.5 V)	$C_L = 1000\text{ pF}$		1.5		ns	
t_{PW}	Minimum input pulse width that changes the output			10		ns	
t_{BS}	Bootstrap diode reverse recovery time	$I_F = 100\text{ mA}$, $I_R = 100\text{ mA}$		40		ns	

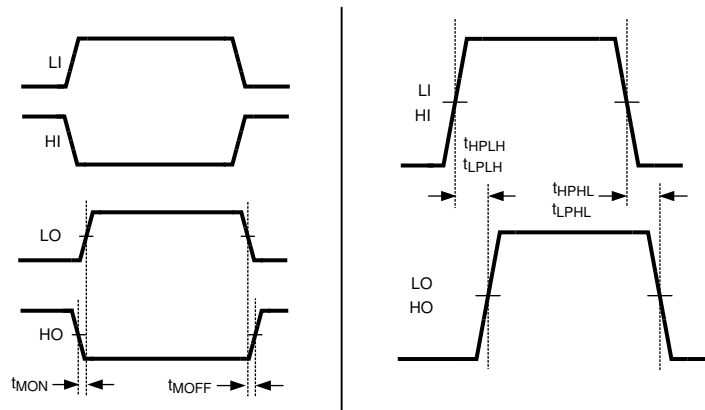
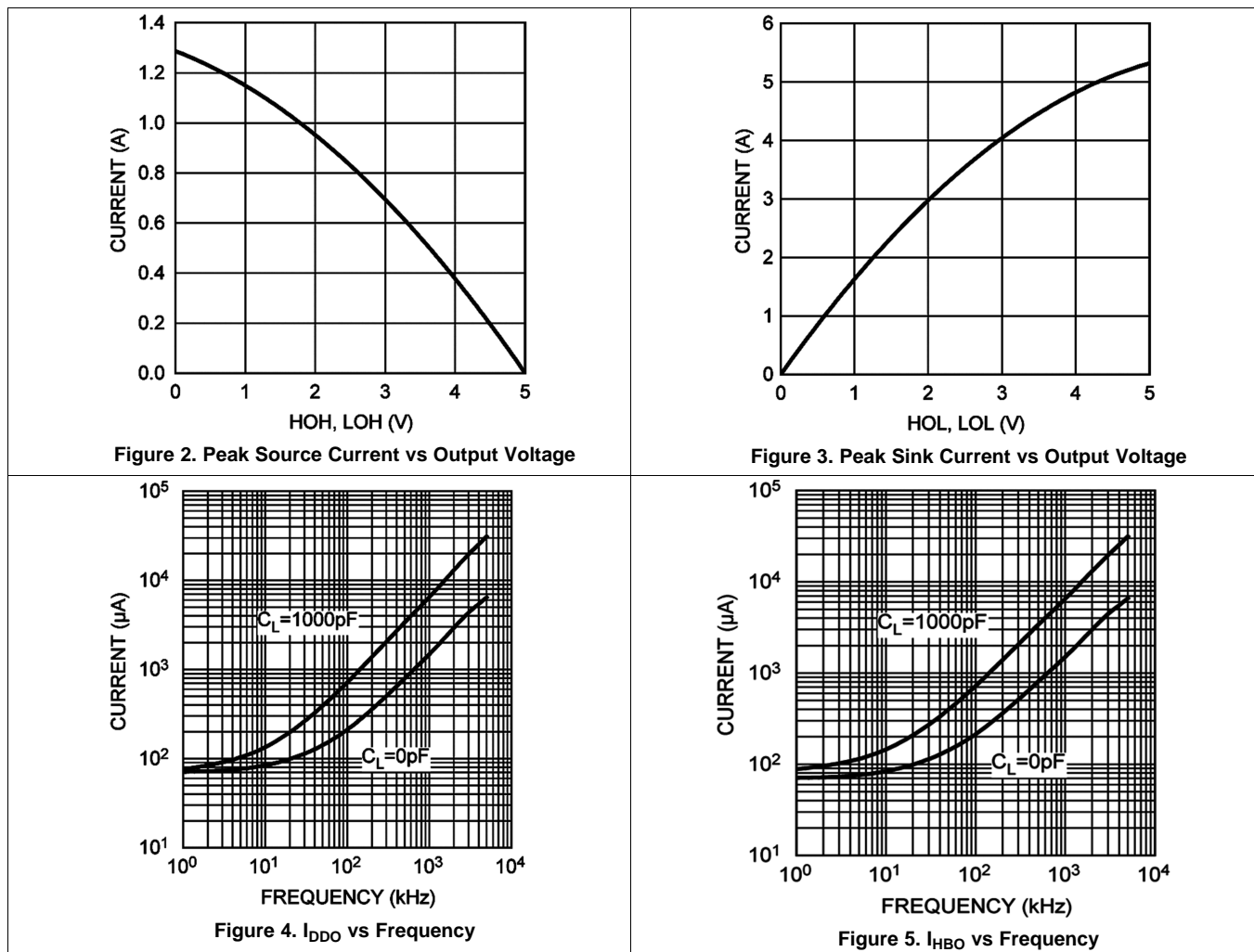

Figure 1. Timing Diagram

6.7 Typical Characteristics



Typical Characteristics (continued)

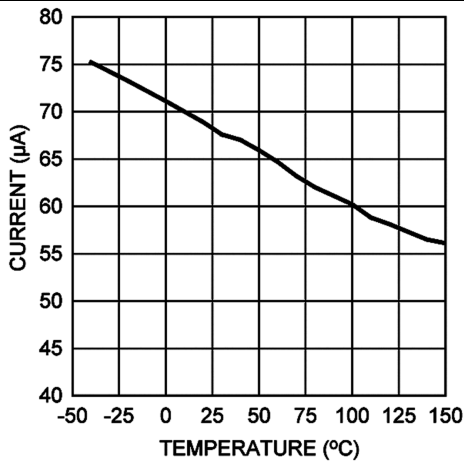

Figure 6. I_{DD} vs Temperature

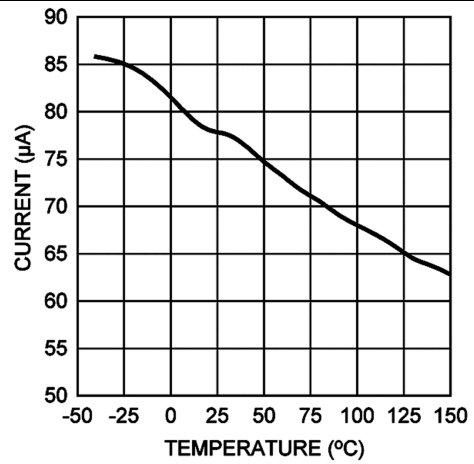

Figure 7. I_{HB} vs Temperature

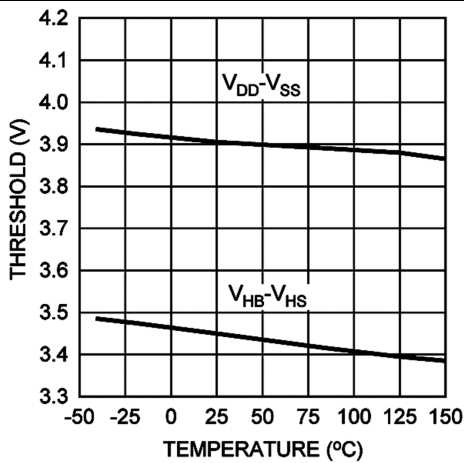

Figure 8. UVLO Rising Thresholds vs Temperature

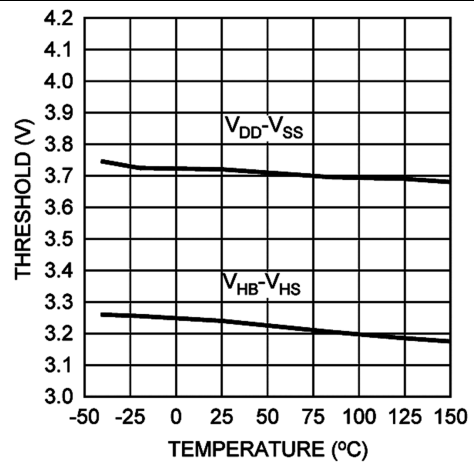

Figure 9. UVLO Falling Thresholds vs Temperature

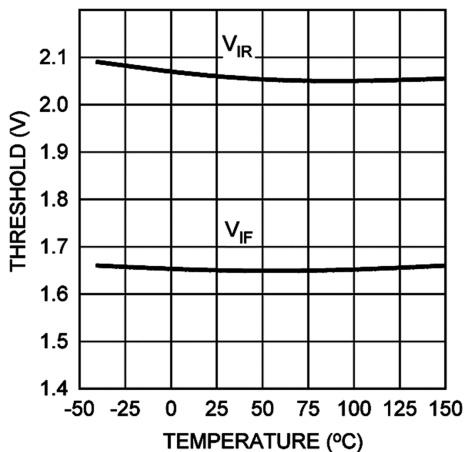

Figure 10. Input Thresholds vs Temperature

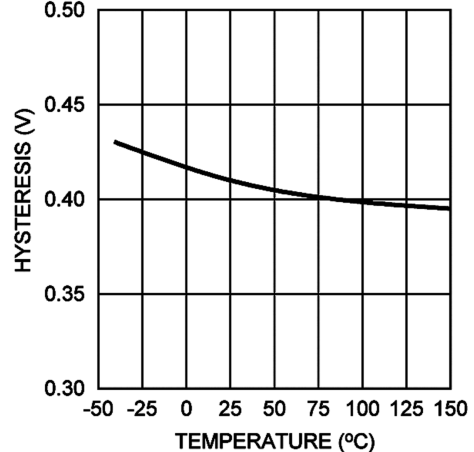

Figure 11. Input Threshold Hysteresis vs Temperature

Typical Characteristics (continued)

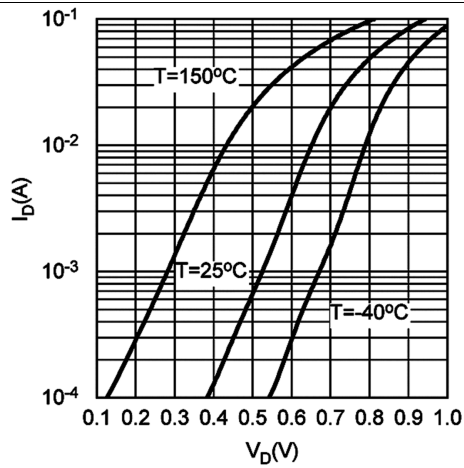

Figure 12. Bootstrap Diode Forward Voltage

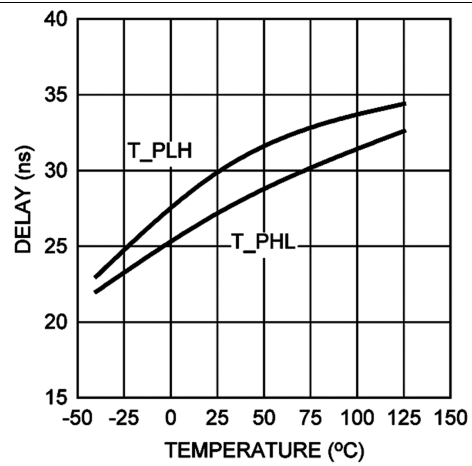
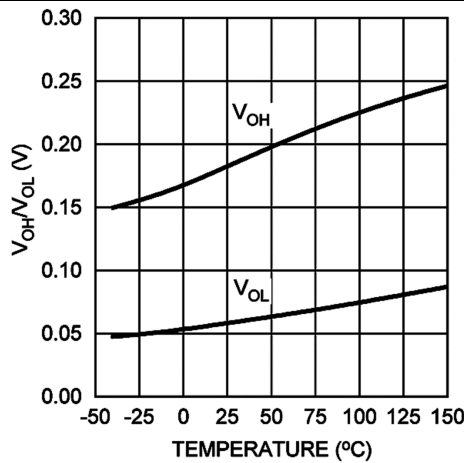
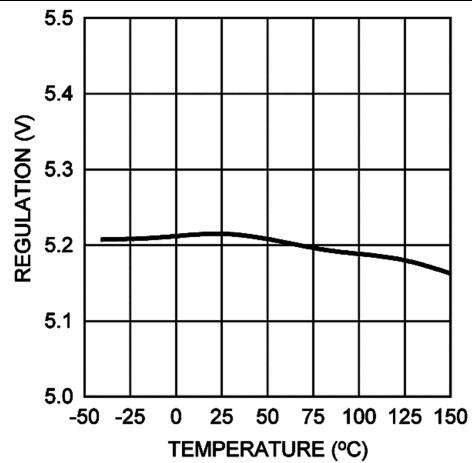

Figure 13. Propagation Delay vs Temperature



Note: Unless otherwise specified,
VDD = VHB = 5 V, VSS = VHS = 0 V.

Figure 14. LO & HO Gate Drive – High/Low Level Output Voltage vs Temperature



Note: Unless otherwise specified,
VDD = VHB = 5 V, VSS = VHS = 0 V.

Figure 15. HB Regulation Voltage vs Temperature

7 Detailed Description

7.1 Overview

The LM5113 is a high frequency high- and low- side gate driver for enhancement mode Gallium Nitride (GaN) FETs in a synchronous buck or a half bridge configuration. The floating high-side driver is capable of driving a high-side enhancement mode GaN FET operating up to 100 V. The high-side bias voltage is generated using a bootstrap technique and is internally clamped at 5.2 V, which prevents the gate voltage from exceeding the maximum gate-source voltage rating of enhancement mode GaN FETs. The LM5113 has split gate outputs with strong sink capability, providing flexibility to adjust the turnon and turnoff strength independently.

The LM5113 can operate up to several MHz, and available in a standard WSON-10 pin package and a 12-bump DSBGA package. The WSON-10 pin package contains an exposed pad to aid power dissipation. The DSBGA package offers a compact footprint and minimized package inductance.

7.2 Functional Block Diagram

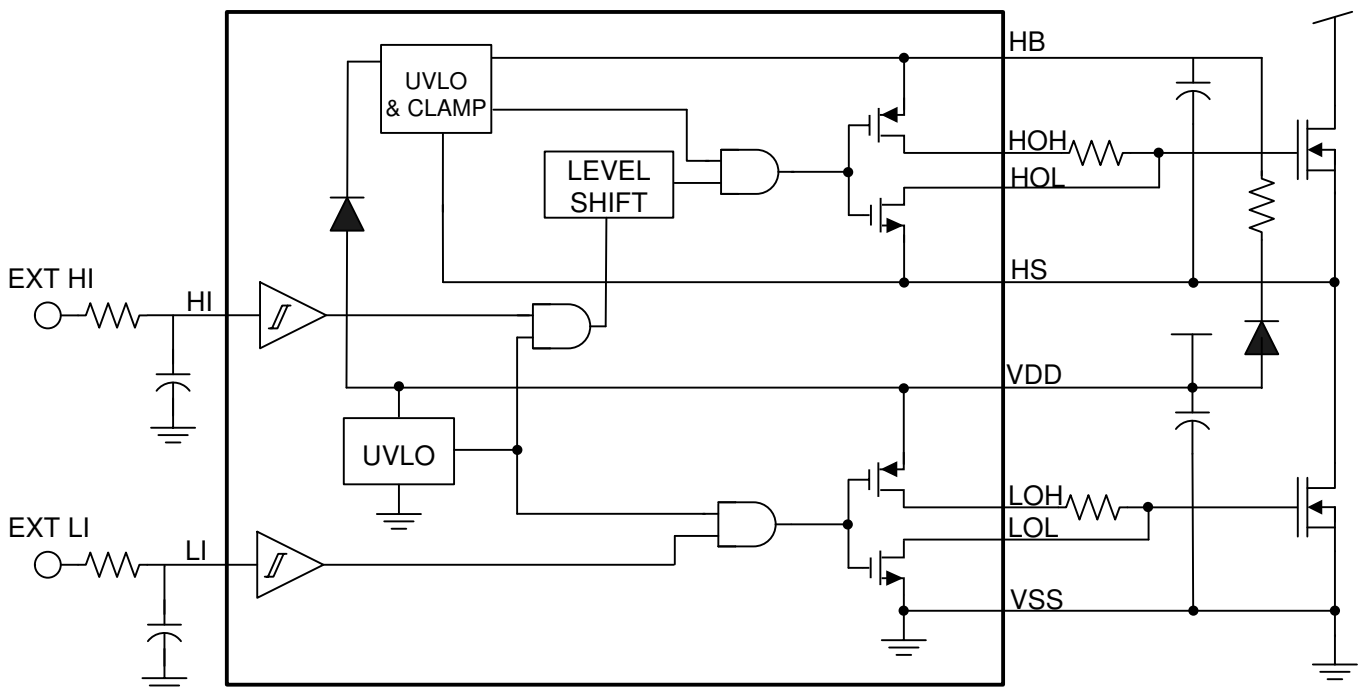

Copyright © 2017, Texas Instruments Incorporated

7.3 Feature Description

7.3.1 Input and Output

The inputs are independently controlled with TTL input thresholds, and can withstand voltages up to 14 V regardless of the VDD voltage, which means it could be directly connected to the outputs of PWM controllers with up to 14-V power supply, saving a buffer stage between output of higher-voltage powered controller, for example LM5025 with 10 V, and input of the LM5113.

The output pulldown and pullup resistance of LM5113 is optimized for enhancement mode GaN FETs to achieve high frequency and efficient operation. The 0.6- Ω pulldown resistance provides a robust low impedance turnoff path necessary to eliminate undesired turnon induced by high dv/dt or high di/dt. The 2.1- Ω pullup resistance helps reduce the ringing and over-shoot of the switch node voltage. The split outputs of the LM5113 offer flexibility to adjust the turnon and turnoff speed by independently adding additional impedance in either the turnon path, the turnoff path, or both.

Feature Description (continued)

It is very important that the input signal of the two channels HI and LI, which has logic compatible threshold and hysteresis, must be tied to either VDD or VSS if they are not used. This inputs must not be left floating.

Additionally, the input signals avoid pulses shorter than 3 ns by using the input filter to the HI and LI input pins. The values and part numbers of the circuit components are shown in the [Figure 16](#).

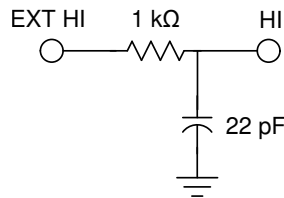
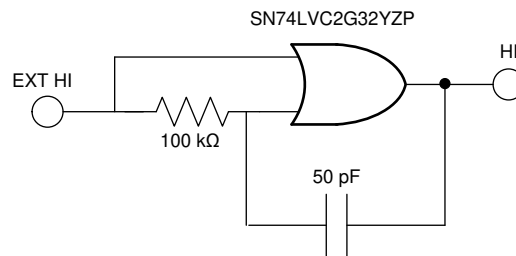

Figure 16. Input Filter 1 (High-Side Input Filter)

If short pulses or short delays are required, the circuit in [Figure 17](#) is recommended.



Copyright © 2017, Texas Instruments Incorporated

Figure 17. Input Filter 1 for Short Pulses (High-Side Input Filter)

7.3.2 Start-Up and UVLO

The start-up voltage sequencing for this device is as follows: VDD voltage first, with the VIN voltage present thereafter.

The LM5113 requires an external bootstrap diode with a 20-Ω series resistor to charge the high-side supply on a cycle-by-cycle basis. The recommended bootstrap diode options are BAT46, BAT41, or LL4148.

The LM5113 has an Undervoltage Lockout (UVLO) on both the VDD and bootstrap supplies. When the VDD voltage is below the threshold voltage of 3.8 V, both the HI and LI inputs are ignored, to prevent the GaN FETs from being partially turned on. Also if there is insufficient VDD voltage, the UVLO will actively pull the LOL and HOL low. When the HB to HS bootstrap voltage is below the UVLO threshold of 3.2 V, only HOL is pulled low. Both UVLO threshold voltages have 200 mV of hysteresis to avoid chattering.

Table 1. VDD UVLO Feature Logic Operation

CONDITION ($V_{HB-HS} > V_{HBR}$ for all cases below)	HI	LI	HO	LO
$V_{DD} - V_{SS} < V_{DDR}$ during device start-up	H	L	L	L
$V_{DD} - V_{SS} < V_{DDR}$ during device start-up	L	H	L	L
$V_{DD} - V_{SS} < V_{DDR}$ during device start-up	H	H	L	L
$V_{DD} - V_{SS} < V_{DDR}$ during device start-up	L	L	L	L
$V_{DD} - V_{SS} < V_{DDR} - V_{DDH}$ after device start-up	H	L	L	L
$V_{DD} - V_{SS} < V_{DDR} - V_{DDH}$ after device start-up	L	H	L	L
$V_{DD} - V_{SS} < V_{DDR} - V_{DDH}$ after device start-up	H	H	L	L
$V_{DD} - V_{SS} < V_{DDR} - V_{DDH}$ after device start-up	L	L	L	L

Table 2. V_{HB-HS} UVLO Feature Logic Operation

CONDITION ($V_{DD} > V_{DDR}$ for all cases below)	HI	LI	HO	LO
$V_{HB-HS} < V_{HBR}$ during device start-up	H	L	L	L
$V_{HB-HS} < V_{HBR}$ during device start-up	L	H	L	H
$V_{HB-HS} < V_{HBR}$ during device start-up	H	H	L	H
$V_{HB-HS} < V_{HBR}$ during device start-up	L	L	L	L
$V_{HB-HS} < V_{HBR} - V_{HBH}$ after device start-up	H	L	L	L
$V_{HB-HS} < V_{HBR} - V_{HBH}$ after device start-up	L	H	L	H
$V_{HB-HS} < V_{HBR} - V_{HBH}$ after device start-up	H	H	L	H
$V_{HB-HS} < V_{HBR} - V_{HBH}$ after device start-up	L	L	L	L

7.3.3 HS Negative Voltage and Bootstrap Supply Voltage Clamping

Due to the intrinsic feature of enhancement mode GaN FETs, the source-to-drain voltage of the bottom switch, is usually higher than a diode forward voltage drop when the gate is pulled low. This will cause negative voltage on HS pin. Moreover, this negative voltage transient will be even worse, considering layout and device drain/source parasitic inductances. With high side driver using the floating bootstrap configuration, Negative HS voltage can lead to an excessive bootstrap voltage which can damage the high-side GaN FET. The LM5113 solves this problem with an internal clamping circuit that prevents the bootstrap voltage from exceeding 5.2 V typical.

7.3.4 Level Shift

The level shift circuit is the interface from the high-side input to the high-side driver stage which is referenced to the switch node (HS). The level shift allows control of the HO output which is referenced to the HS pin and provides excellent delay matching with the low-side driver. Typical delay matching between LO and HO is around 1.5 ns.

7.4 Device Functional Modes

Table 3 shows the device truth table.

Table 3. Truth Table

HI	LI	HOH	HOL	LOH	LOL
L	L	Open	L	Open	L
L	H	Open	L	H	Open
H	L	H	Open	Open	L
H	H	H	Open	H	Open

8 Application and Implementation

NOTE

Information in the following applications sections is not part of the TI component specification, and TI does not warrant its accuracy or completeness. TI's customers are responsible for determining suitability of components for their purposes. Customers should validate and test their design implementation to confirm system functionality.

8.1 Application Information

To operate GaN transistors at very high switching frequencies and to reduce associated switching losses, a powerful gate driver is employed between the PWM output of controller and the gates of the GaN transistor. Also, gate drivers are indispensable when it is impossible for the PWM controller to directly drive the gates of the switching devices. With the advent of digital power, this situation is often encountered because the PWM signal from the digital controller is often a 3.3-V logic signal which cannot effectively turn on a power switch. Level shift circuit is required to boost the 3.3-V signal to the gate-drive voltage (such as 12 V) in order to fully turn on the power device and minimize conduction losses. Traditional buffer drive circuits based on NPN/PNP bipolar transistors in totem-pole arrangement prove inadequate with digital power because they lack level-shifting capability. Gate drivers effectively combine both the level-shifting and buffer-drive functions. Gate drivers also find other needs such as minimizing the effect of high-frequency switching noise (by placing the high-current driver IC physically close to the power switch), driving gate-drive transformers and controlling floating power-device gates, reducing power dissipation and thermal stress in controllers by moving gate charge power losses from the controller into the driver.

The LM5113 is a MHz high- and low-side gate driver for enhancement mode Gallium Nitride (GaN) FETs in a synchronous buck or a half bridge configuration. The floating high-side driver is capable of driving a high-side enhancement mode GaN FET operating up to 100 V. The high-side bias voltage is generated using a bootstrap technique and is internally clamped at 5.2 V, which prevents the gate voltage from exceeding the maximum gate-source voltage rating of enhancement mode GaN FETs. The LM5113 has split gate outputs with strong sink capability, providing flexibility to adjust the turnon and turnoff strength independently.

8.2 Typical Application

The circuit in [Figure 18](#) shows a synchronous buck converter to evaluate LM5113. Detailed synchronous buck converter specifications are listed in [Design Requirements](#). The active clamping voltage mode controller LM5025 is used for close-loop control and generates the PWM signals of the buck switch and the synchronous switch. For more information, refer to the [Related Documentation](#) section.

Typical Application (continued)

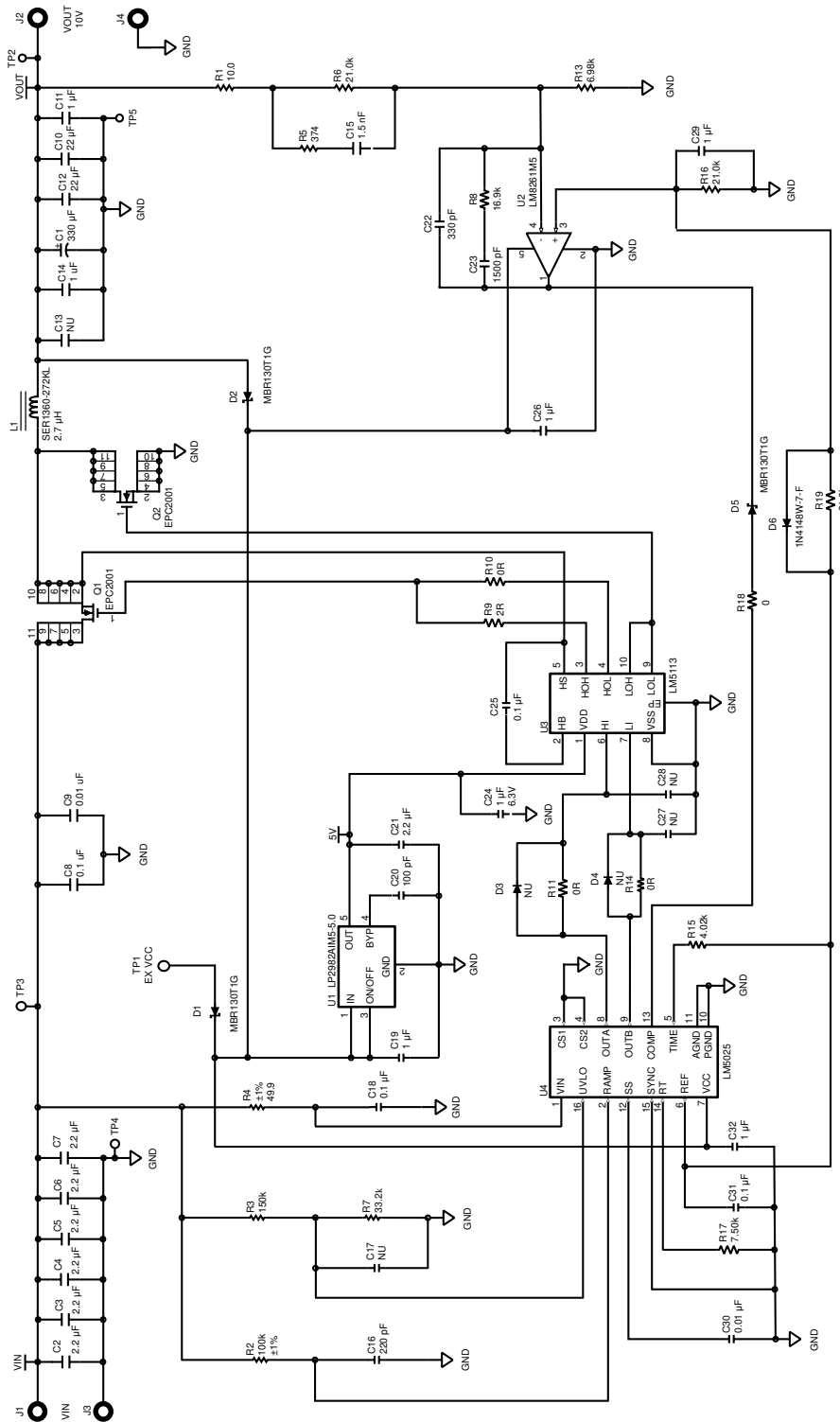

Input 15 V to 60 V, output 10 V, 800 kHz

Figure 18. Application Circuit

Typical Application (continued)

8.2.1 Design Requirements

Table 4 lists the design requirements for the typical application.

Table 4. Design Parameters

PARAMETER	SPECIFICATION
Input operating range	15 – 60 V
Output voltage	10 V
Output current, 48-V input	10 A
Output current, 60-V input	7 A
Efficiency at 48 V, 10 A	>90%
Frequency	800 kHz

8.2.2 Detailed Design Procedure

This procedure outlines the design considerations of LM5113 in a synchronous buck converter with enhancement mode Gallium Nitride (GaN) FET. Refer to Figure 18 for component names and network locations. For additional design help, see [Related Documentation](#).

8.2.2.1 VDD Bypass Capacitor

The VDD bypass capacitor provides the gate charge for the low-side and high-side transistors and to absorb the reverse recovery charge of the bootstrap diode. The required bypass capacitance can be calculated with Equation 1.

$$C_{VDD} > \frac{Q_{gH} + Q_{gL} + Q_{rr}}{\Delta V} \quad (1)$$

Q_{gH} and Q_{gL} are gate charge of the high-side and low-side transistors respectively. Q_{rr} is the reverse recovery charge of the bootstrap diode, which is typically around 4 nC. ΔV is the maximum allowable voltage drop across the bypass capacitor. A 0.1- μ F or larger value, good-quality, ceramic capacitor is recommended. The bypass capacitor should be placed as close to the pins of the IC as possible to minimize the parasitic inductance.

8.2.2.2 Bootstrap Capacitor

The bootstrap capacitor provides the gate charge for the high-side switch, DC bias power for HB undervoltage lockout circuit, and the reverse recovery charge of the bootstrap diode. The required bypass capacitance can be calculated with Equation 2.

$$C_{BST} > \frac{Q_{gH} + I_{HB} \times t_{ON} + Q_{rr}}{\Delta V} \quad (2)$$

I_{HB} is the quiescent current of the high-side driver. t_{on} is the maximum on-time period of the high-side transistor. A good-quality, ceramic capacitor should be used for the bootstrap capacitor. TI recommends placing the bootstrap capacitor as close to the HB and HS pins as possible.

8.2.2.3 Power Dissipation

The power consumption of the driver is an important measure that determines the maximum achievable operating frequency of the driver. It should be kept below the maximum power dissipation limit of the package at the operating temperature. The total power dissipation of the LM5113 is the sum of the gate driver losses and the bootstrap diode power loss.

The gate driver losses are incurred by charge and discharge of the capacitive load. It can be approximated as:

$$P = (C_{LoadH} + C_{LoadL}) \times V_{DD}^2 \times f_{SW} \quad (3)$$

C_{LoadH} and C_{LoadL} are the high-side and the low-side capacitive loads, respectively. It can also be calculated with the total input gate charge of the high-side and the low-side transistors as:

$$P = (Q_{gH} + Q_{gL}) \times V_{DD} \times f_{SW} \quad (4)$$

There are some additional losses in the gate drivers due to the internal CMOS stages used to buffer the LO and HO outputs. The following plot shows the measured gate driver power dissipation versus frequency and load capacitance. At higher frequencies and load capacitance values, the power dissipation is dominated by the power losses driving the output loads and agrees well with the above equations. This plot can be used to approximate the power losses due to the gate drivers.

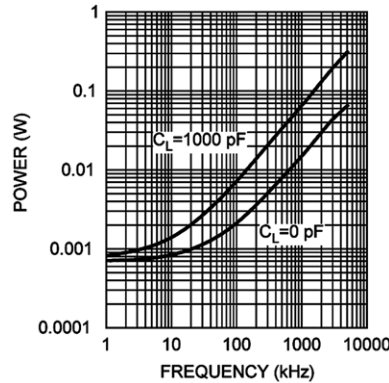

Gate Driver Power Dissipation (LO+HO), VDD = +5 V

Figure 19. Neglecting Bootstrap Diode Losses

The bootstrap diode power loss is the sum of the forward bias power loss that occurs while charging the bootstrap capacitor and the reverse bias power loss that occurs during reverse recovery. Because each of these events happens once per cycle, the diode power loss is proportional to the operating frequency. Larger capacitive loads require more energy to recharge the bootstrap capacitor resulting in more losses. Higher input voltages (V_{IN}) to the half bridge also result in higher reverse recovery losses.

The following two plots illustrate the forward bias power loss and the reverse bias power loss of the bootstrap diode respectively. The plots are generated based on calculations and lab measurements of the diode reverse time and current under several operating conditions. The plots can be used to predict the bootstrap diode power loss under different operating conditions.

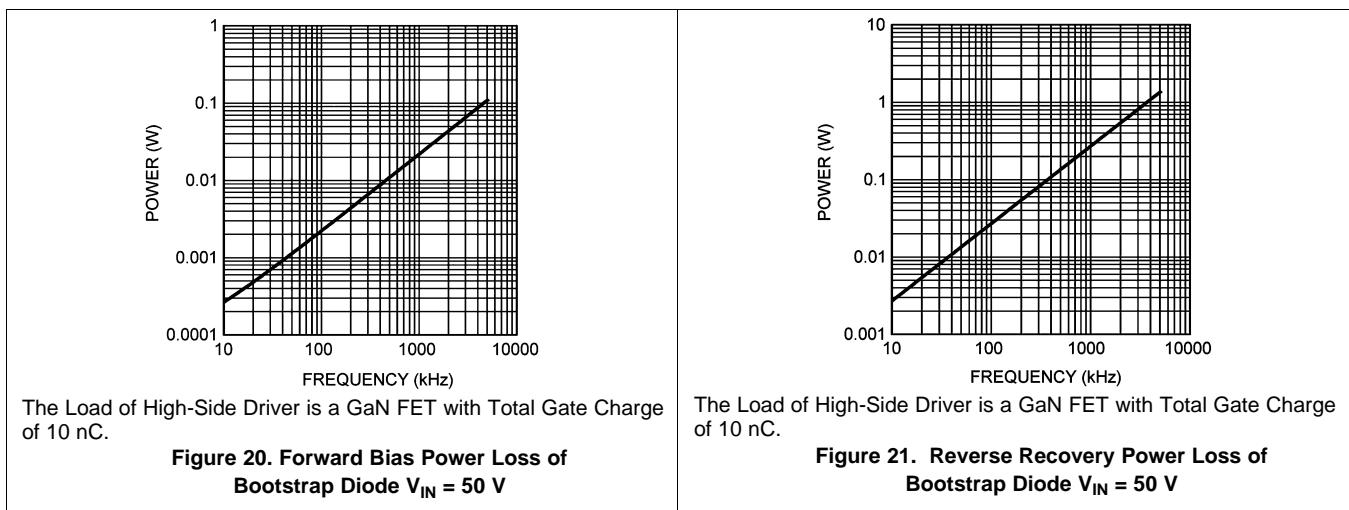

The sum of the driver loss and the bootstrap diode loss is the total power loss of the IC. For a given ambient temperature, the maximum allowable power loss of the IC can be defined as [Equation 5](#).

$$P = \frac{(T_J - T_A)}{\theta_{JA}} \tag{5}$$

8.2.3 Application Curves

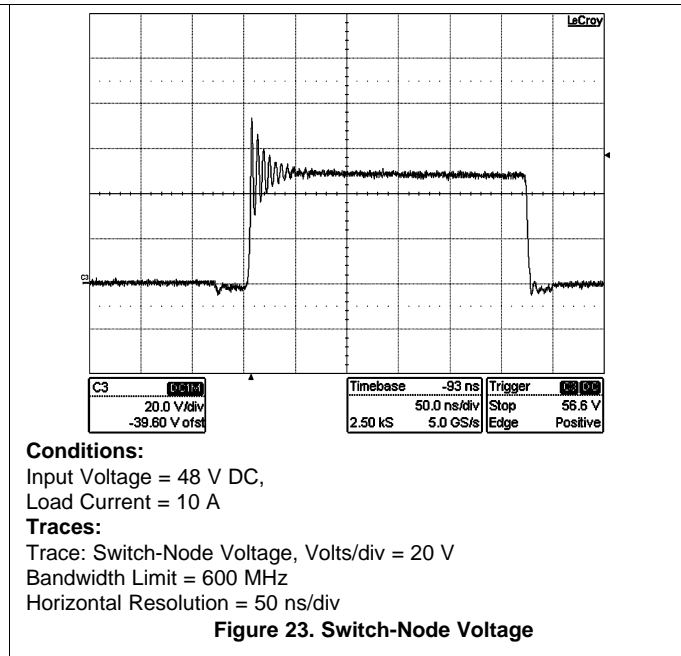
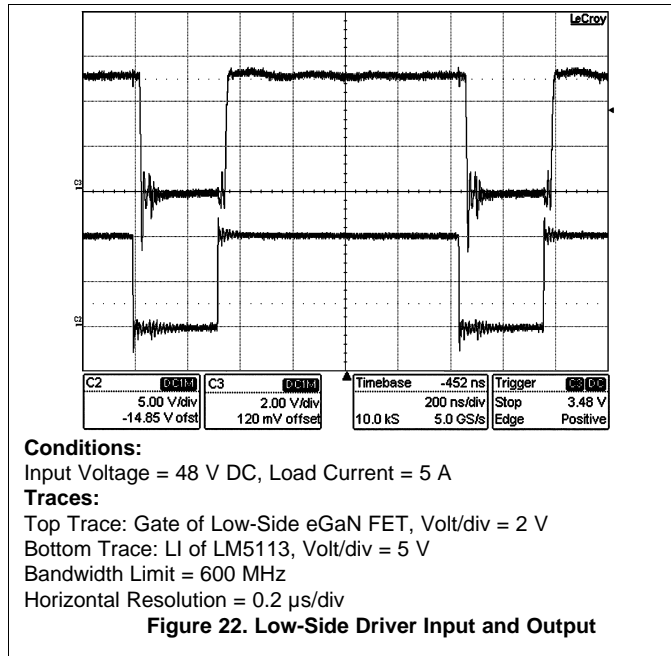

9 Power Supply Recommendations

The recommended bias supply voltage range for LM5113 is from 4.5 V to 5.5 V. The lower end of this range is governed by the internal undervoltage lockout (UVLO) protection feature of the VDD supply circuit. The upper end of this range is driven by the 7-V absolute maximum voltage rating of the VDD or the GaN transistor gate breakdown voltage limit, whichever is lower. TI recommends keeping a proper margin to allow for transient voltage spikes.

The UVLO protection feature also involves a hysteresis function. This means that once the device is operating in normal mode, if the VDD voltage drops, the device continues to operate in normal mode as far as the voltage drop do not exceeds the hysteresis specification, VDDH. If the voltage drop is more than hysteresis specification, the device shuts down. Therefore, while operating at or near the 4.5-V range, the voltage ripple on the auxiliary power supply output should be smaller than the hysteresis specification of LM5113 to avoid triggering device shutdown.

A local bypass capacitor should be placed between the VDD and VSS pins. And this capacitor should be located as close to the device as possible. A low-ESR, ceramic surface mount capacitor is recommended. TI recommends using 2 capacitors across VDD and GND: a 100-nF ceramic surface-mount capacitor for high frequency filtering placed very close to VDD and GND pin, and another surface-mount capacitor, 220-nF to 10- μ F, for IC bias requirements.

10 Layout

10.1 Layout Guidelines

Small gate capacitance and miller capacitance enable enhancement mode GaN FETs to operate with fast switching speed. The induced high dv/dt and di/dt , coupled with a low gate threshold voltage and limited headroom of enhancement mode GaN FETs gate voltage, make the circuit layout crucial to the optimum performance. Following are some hints.

1. The first priority in designing the layout of the driver is to confine the high peak currents that charge and discharge the GaN FETs gate into a minimal physical area. This will decrease the loop inductance and minimize noise issues on the gate terminal of the GaN FETs. The GaN FETs should be placed close to the driver.
2. The second high current path includes the bootstrap capacitor, the local ground referenced VDD bypass capacitor and low-side GaN FET. The bootstrap capacitor is recharged on a cycle-by-cycle basis through the bootstrap diode from the ground referenced VDD capacitor. The recharging occurs in a short time interval and involves high peak current. Minimizing this loop length and area on the circuit board is important to ensure reliable operation.
3. The parasitic inductance in series with the source of the high-side FET and the low-side FET can impose excessive negative voltage transients on the driver. TI recommends connecting the HS pin and VSS pin to the respective source of the high-side and low-side transistors with a short and low-inductance path.
4. The parasitic source inductance, along with the gate capacitor and the driver pulldown path, can form a LCR resonant tank, resulting in gate voltage oscillations. An optional resistor or ferrite bead can be used to damp the ringing.
5. Low ESR/ESL capacitors must be connected close to the IC, between VDD and VSS pins and between the HB and HS pins to support the high peak current being drawn from VDD during turnon of the FETs. Keeping bullet #1 (minimized GaN FETs gate driver loop) as the first priority, it is also desirable to place the VDD decoupling capacitor and the HB to HS bootstrap capacitor on the same side of the printed-circuit board as the driver. The inductance of vias can impose excessive ringing on the IC pins.
6. To prevent excessive ringing on the input power bus, good decoupling practices are required by placing low-ESR ceramic capacitors adjacent to the GaN FETs.

The following figures show recommended layout patterns for WSON-10 package and DSBGA package, respectively. Two cases are considered: (1) Without any gate resistors; (2) With an optional turnon gate resistor. It should be noted that 0402 DSBGA package is assumed for the passive components in the drawings. For information on DSBGA package assembly, refer to [Related Documentation](#).

10.2 Layout Examples

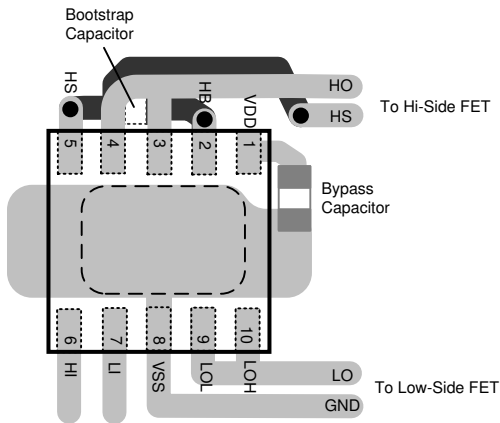

Figure 24. WSON-10 Without Gate Resistors

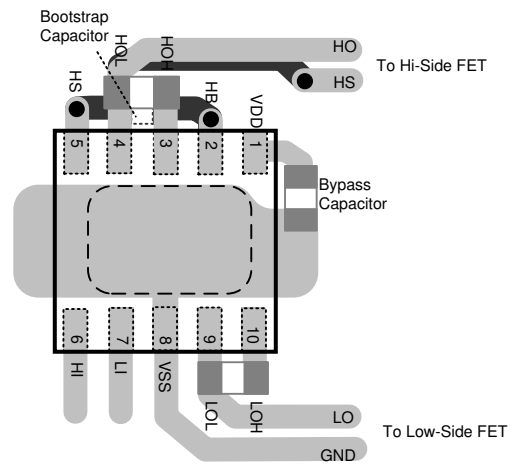

Figure 25. WSON-10 With HOH and LOH Gate Resistors

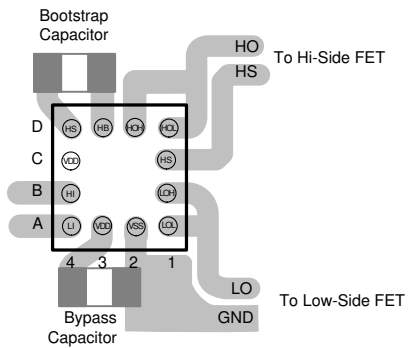

Figure 26. DSBGA Without Gate Resistors

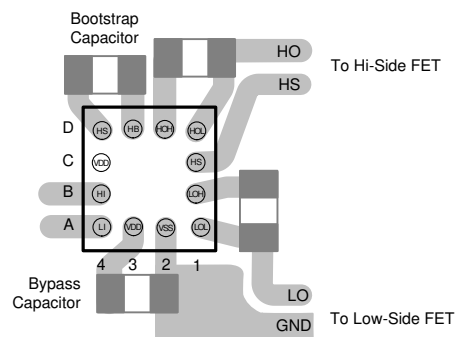

Figure 27. DSBGA With HOH and LOH Gate Resistors

11 Device and Documentation Support

11.1 Documentation Support

11.1.1 Related Documentation

For related documentation see the following:

- Texas Instruments, [AN-1112 DSBGA Wafer Level Chip Scale Package Application Report](#)
- Texas Instruments, [AN-2149 LM5113 Evaluation Board Application Report](#)

11.2 Support Resources

TI E2E™ [support forums](#) are an engineer's go-to source for fast, verified answers and design help — straight from the experts. Search existing answers or ask your own question to get the quick design help you need.

Linked content is provided "AS IS" by the respective contributors. They do not constitute TI specifications and do not necessarily reflect TI's views; see TI's [Terms of Use](#).

11.3 Trademarks

E2E is a trademark of Texas Instruments.

All other trademarks are the property of their respective owners.

11.4 Electrostatic Discharge Caution



These devices have limited built-in ESD protection. The leads should be shorted together or the device placed in conductive foam during storage or handling to prevent electrostatic damage to the MOS gates.

11.5 Glossary

[SLYZ022](#) — *TI Glossary*.

This glossary lists and explains terms, acronyms, and definitions.

12 Mechanical, Packaging, and Orderable Information

The following pages include mechanical, packaging, and orderable information. This information is the most current data available for the designated devices. This data is subject to change without notice and revision of this document. For browser-based versions of this datasheet, refer to the left-hand navigation.

PACKAGING INFORMATION

Orderable Device	Status (1)	Package Type	Package Drawing	Pins	Package Qty	Eco Plan (2)	Lead finish/ Ball material (6)	MSL Peak Temp (3)	Op Temp (°C)	Device Marking (4/5)	Samples
LM5113SD/NOPB	NRND	WSON	DPR	10	1000	RoHS & Green	SN	Level-1-260C-UNLIM	-40 to 125	L5113	
LM5113SDE/NOPB	NRND	WSON	DPR	10	250	RoHS & Green	SN	Level-1-260C-UNLIM	-40 to 125	L5113	
LM5113SDX/NOPB	NRND	WSON	DPR	10	4500	RoHS & Green	SN	Level-1-260C-UNLIM	-40 to 125	L5113	
LM5113TME/NOPB	NRND	DSBGA	YFX	12	250	RoHS & Green	SNAGCU	Level-1-260C-UNLIM		5113	
LM5113TMX/NOPB	NRND	DSBGA	YFX	12	3000	RoHS & Green	SNAGCU	Level-1-260C-UNLIM		5113	

(1) The marketing status values are defined as follows:

ACTIVE: Product device recommended for new designs.

LIFEBUY: TI has announced that the device will be discontinued, and a lifetime-buy period is in effect.

NRND: Not recommended for new designs. Device is in production to support existing customers, but TI does not recommend using this part in a new design.

PREVIEW: Device has been announced but is not in production. Samples may or may not be available.

OBSOLETE: TI has discontinued the production of the device.

(2) **RoHS:** TI defines "RoHS" to mean semiconductor products that are compliant with the current EU RoHS requirements for all 10 RoHS substances, including the requirement that RoHS substance do not exceed 0.1% by weight in homogeneous materials. Where designed to be soldered at high temperatures, "RoHS" products are suitable for use in specified lead-free processes. TI may reference these types of products as "Pb-Free".

RoHS Exempt: TI defines "RoHS Exempt" to mean products that contain lead but are compliant with EU RoHS pursuant to a specific EU RoHS exemption.

Green: TI defines "Green" to mean the content of Chlorine (Cl) and Bromine (Br) based flame retardants meet JS709B low halogen requirements of <=1000ppm threshold. Antimony trioxide based flame retardants must also meet the <=1000ppm threshold requirement.

(3) MSL, Peak Temp. - The Moisture Sensitivity Level rating according to the JEDEC industry standard classifications, and peak solder temperature.

(4) There may be additional marking, which relates to the logo, the lot trace code information, or the environmental category on the device.

(5) Multiple Device Markings will be inside parentheses. Only one Device Marking contained in parentheses and separated by a "~" will appear on a device. If a line is indented then it is a continuation of the previous line and the two combined represent the entire Device Marking for that device.

(6) Lead finish/Ball material - Orderable Devices may have multiple material finish options. Finish options are separated by a vertical ruled line. Lead finish/Ball material values may wrap to two lines if the finish value exceeds the maximum column width.

Important Information and Disclaimer: The information provided on this page represents TI's knowledge and belief as of the date that it is provided. TI bases its knowledge and belief on information provided by third parties, and makes no representation or warranty as to the accuracy of such information. Efforts are underway to better integrate information from third parties. TI has taken and continues to take reasonable steps to provide representative and accurate information but may not have conducted destructive testing or chemical analysis on incoming materials and chemicals. TI and TI suppliers consider certain information to be proprietary, and thus CAS numbers and other limited information may not be available for release.

In no event shall TI's liability arising out of such information exceed the total purchase price of the TI part(s) at issue in this document sold by TI to Customer on an annual basis.

OTHER QUALIFIED VERSIONS OF LM5113 :

- Automotive: [LM5113-Q1](#)

NOTE: Qualified Version Definitions:

- Automotive - Q100 devices qualified for high-reliability automotive applications targeting zero defects

TAPE AND REEL INFORMATION

QUADRANT ASSIGNMENTS FOR PIN 1 ORIENTATION IN TAPE



*All dimensions are nominal

Device	Package Type	Package Drawing	Pins	SPQ	Reel Diameter (mm)	Reel Width W1 (mm)	A0 (mm)	B0 (mm)	K0 (mm)	P1 (mm)	W (mm)	Pin1 Quadrant
LM5113SD/NOPB	WSON	DPR	10	1000	178.0	12.4	4.3	4.3	1.3	8.0	12.0	Q1
LM5113SDE/NOPB	WSON	DPR	10	250	178.0	12.4	4.3	4.3	1.3	8.0	12.0	Q1
LM5113SDX/NOPB	WSON	DPR	10	4500	330.0	12.4	4.3	4.3	1.3	8.0	12.0	Q1
LM5113TME/NOPB	DSBGA	YFX	12	250	178.0	8.4	1.85	2.01	0.76	4.0	8.0	Q1
LM5113TMX/NOPB	DSBGA	YFX	12	3000	178.0	8.4	1.85	2.01	0.76	4.0	8.0	Q1

TAPE AND REEL BOX DIMENSIONS

*All dimensions are nominal

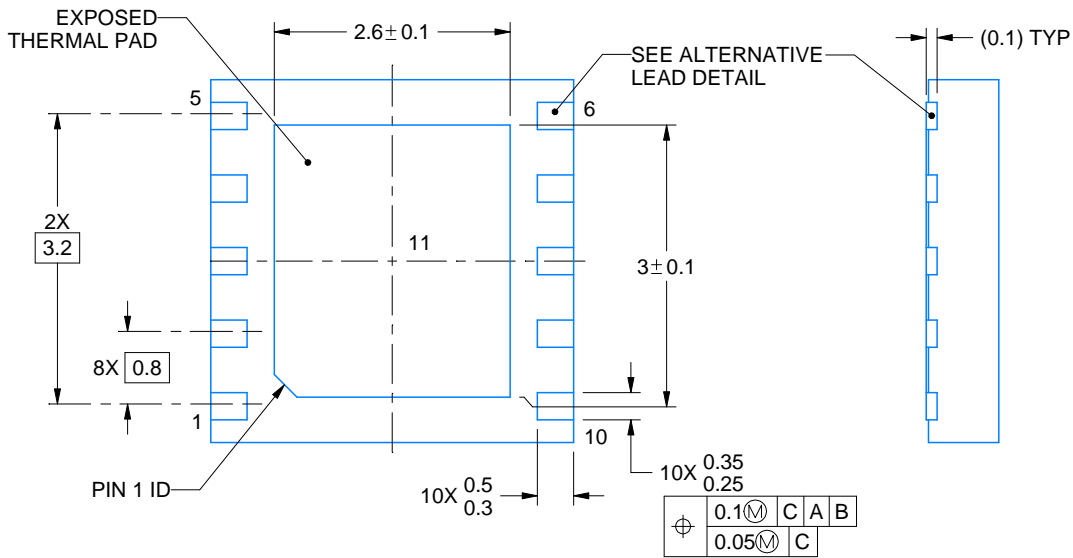
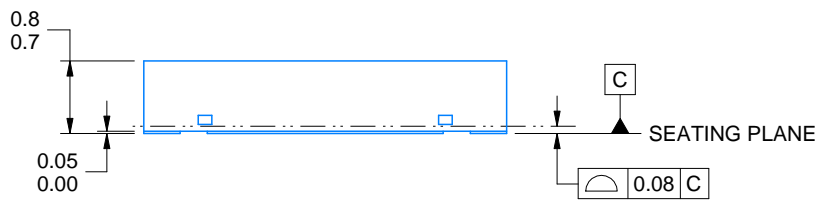
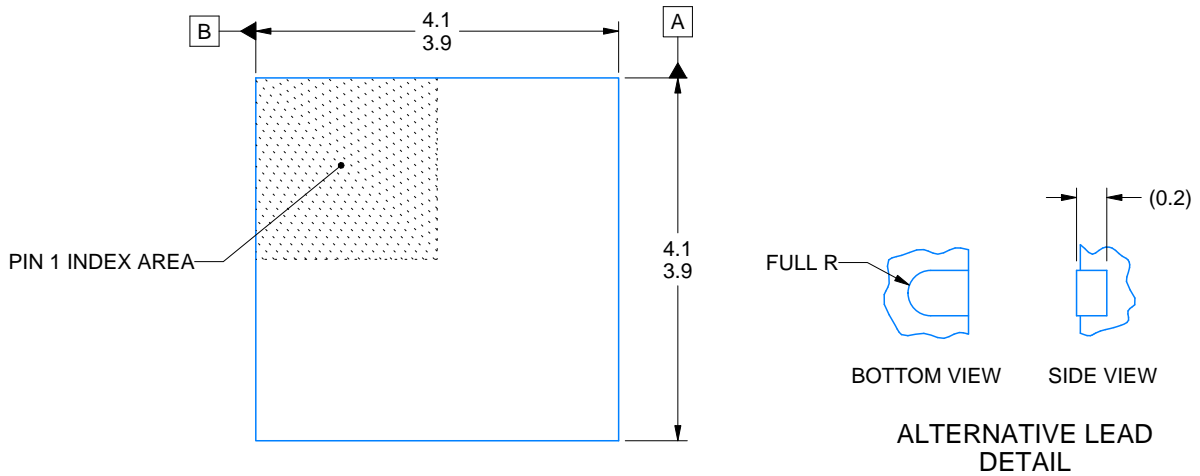
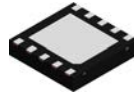
Device	Package Type	Package Drawing	Pins	SPQ	Length (mm)	Width (mm)	Height (mm)
LM5113SD/NOPB	WSON	DPR	10	1000	208.0	191.0	35.0
LM5113SDE/NOPB	WSON	DPR	10	250	208.0	191.0	35.0
LM5113SDX/NOPB	WSON	DPR	10	4500	367.0	367.0	35.0
LM5113TME/NOPB	DSBGA	YFX	12	250	208.0	191.0	35.0
LM5113TMX/NOPB	DSBGA	YFX	12	3000	208.0	191.0	35.0



4218856/B 01/2021

NOTES:

1. All linear dimensions are in millimeters. Any dimensions in parenthesis are for reference only. Dimensioning and tolerancing per ASME Y14.5M.
2. This drawing is subject to change without notice.
3. The package thermal pad must be soldered to the printed circuit board for thermal and mechanical performance.

EXAMPLE BOARD LAYOUT

DPR0010A

WSON - 0.8 mm max height

PLASTIC SMALL OUTLINE - NO LEAD

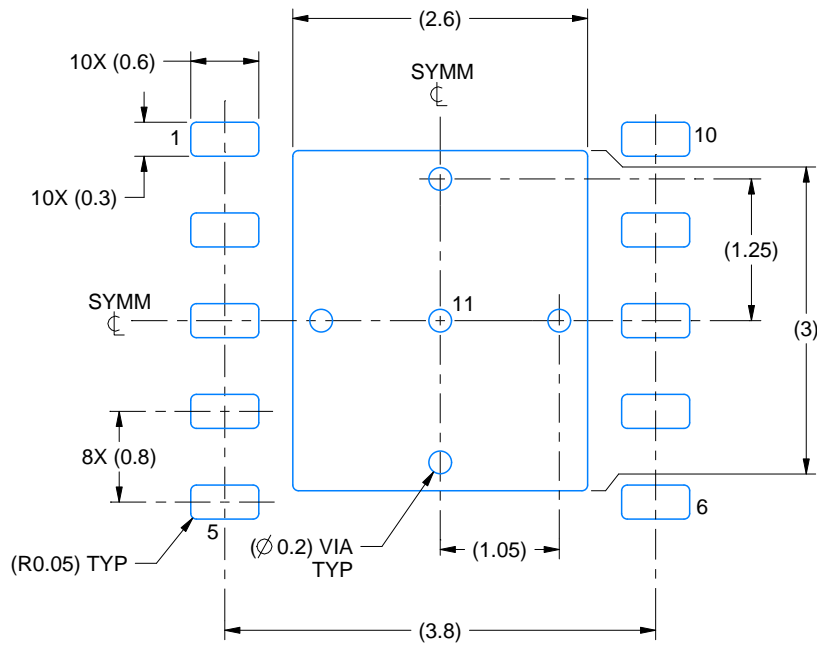

LAND PATTERN EXAMPLE
EXPOSED METAL SHOWN
SCALE:15X

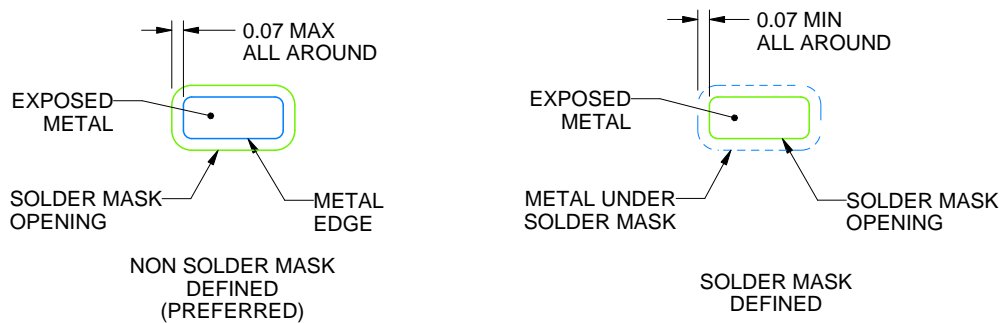

SOLDER MASK DETAILS

4218856/B 01/2021

NOTES: (continued)

4. This package is designed to be soldered to a thermal pad on the board. For more information, see Texas Instruments literature number SLUA271 (www.ti.com/lit/slua271).

EXAMPLE STENCIL DESIGN

DPR0010A

WSN - 0.8 mm max height

PLASTIC SMALL OUTLINE - NO LEAD

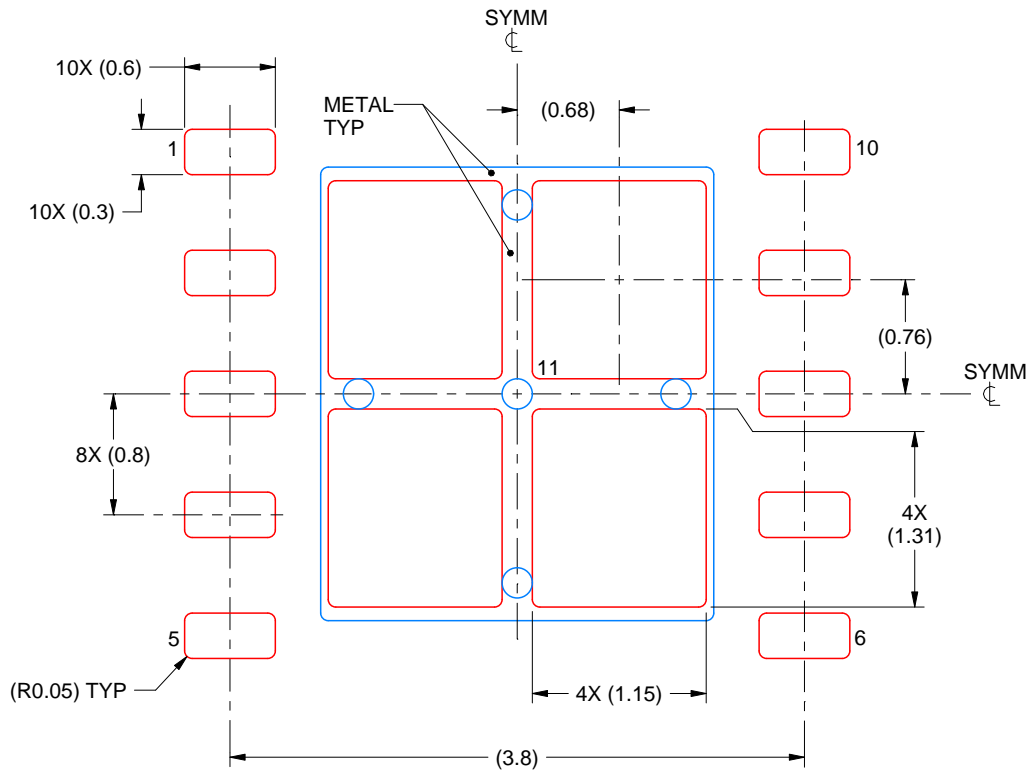

SOLDER PASTE EXAMPLE
BASED ON 0.125 mm THICK STENCIL

EXPOSED PAD 11:
77% PRINTED SOLDER COVERAGE BY AREA
SCALE:20X

4218856/B 01/2021

NOTES: (continued)

5. Laser cutting apertures with trapezoidal walls and rounded corners may offer better paste release. IPC-7525 may have alternate design recommendations.

EXAMPLE BOARD LAYOUT

YFX0012

DSBGA - 0.675 mm max height

DIE SIZE BALL GRID ARRAY

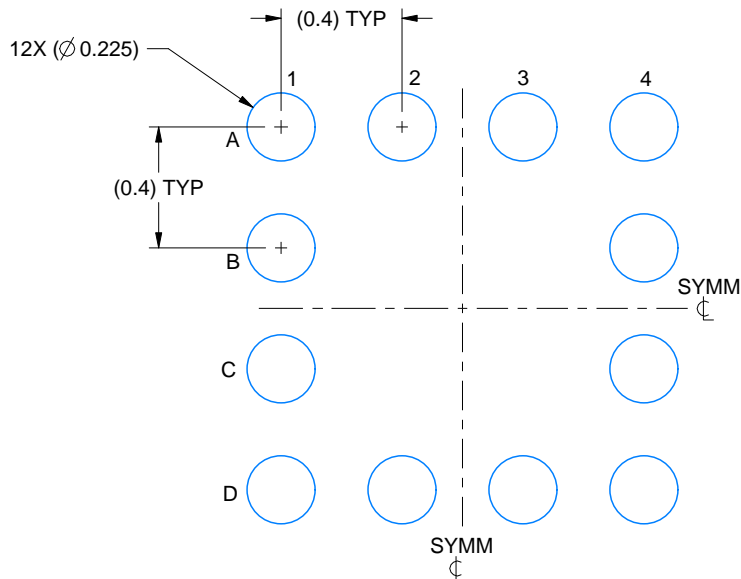

LAND PATTERN EXAMPLE
EXPOSED METAL SHOWN
SCALE: 40X

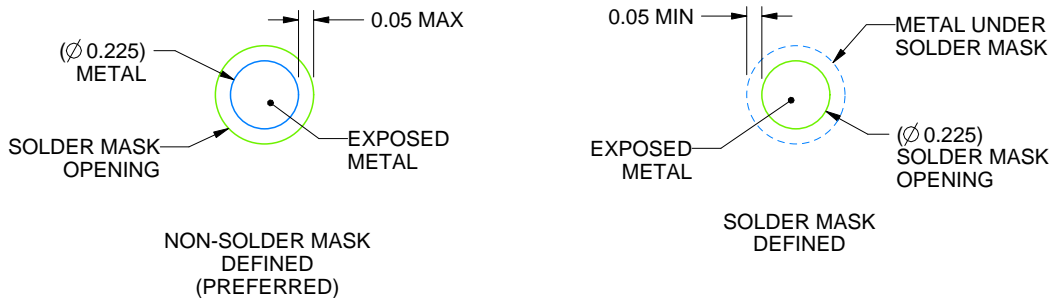

SOLDER MASK DETAILS
NOT TO SCALE

4215094/B 08/2022

NOTES: (continued)

- 3. Final dimensions may vary due to manufacturing tolerance considerations and also routing constraints. See Texas Instruments Literature No. SNVA009 (www.ti.com/lit/snva009).

EXAMPLE STENCIL DESIGN

YFX0012

DSBGA - 0.675 mm max height

DIE SIZE BALL GRID ARRAY

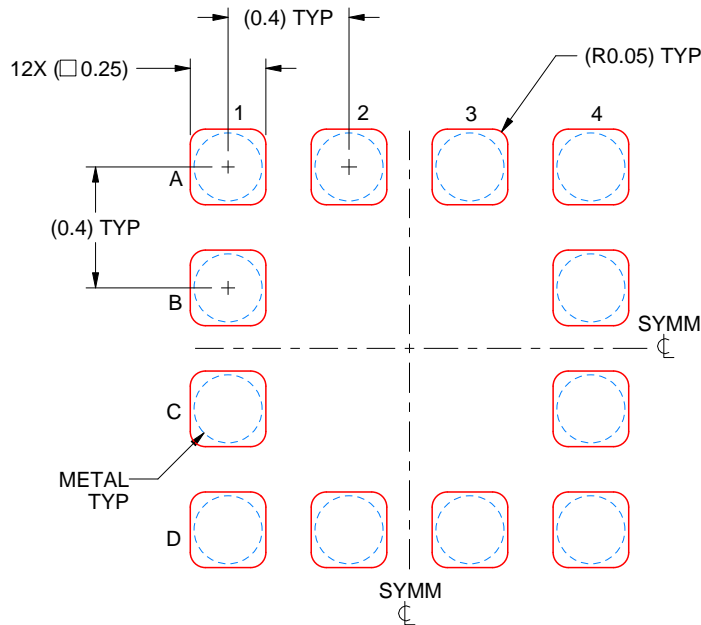

SOLDER PASTE EXAMPLE
BASED ON 0.1 mm THICK STENCIL
SCALE: 40X

4215094/B 08/2022

NOTES: (continued)

4. Laser cutting apertures with trapezoidal walls and rounded corners may offer better paste release.

IMPORTANT NOTICE AND DISCLAIMER

TI PROVIDES TECHNICAL AND RELIABILITY DATA (INCLUDING DATA SHEETS), DESIGN RESOURCES (INCLUDING REFERENCE DESIGNS), APPLICATION OR OTHER DESIGN ADVICE, WEB TOOLS, SAFETY INFORMATION, AND OTHER RESOURCES "AS IS" AND WITH ALL FAULTS, AND DISCLAIMS ALL WARRANTIES, EXPRESS AND IMPLIED, INCLUDING WITHOUT LIMITATION ANY IMPLIED WARRANTIES OF MERCHANTABILITY, FITNESS FOR A PARTICULAR PURPOSE OR NON-INFRINGEMENT OF THIRD PARTY INTELLECTUAL PROPERTY RIGHTS.

These resources are intended for skilled developers designing with TI products. You are solely responsible for (1) selecting the appropriate TI products for your application, (2) designing, validating and testing your application, and (3) ensuring your application meets applicable standards, and any other safety, security, regulatory or other requirements.

These resources are subject to change without notice. TI grants you permission to use these resources only for development of an application that uses the TI products described in the resource. Other reproduction and display of these resources is prohibited. No license is granted to any other TI intellectual property right or to any third party intellectual property right. TI disclaims responsibility for, and you will fully indemnify TI and its representatives against, any claims, damages, costs, losses, and liabilities arising out of your use of these resources.



TI's products are provided subject to [TI's Terms of Sale](#) or other applicable terms available either on [ti.com](https://www.ti.com) or provided in conjunction with such TI products. TI's provision of these resources does not expand or otherwise alter TI's applicable warranties or warranty disclaimers for TI products.

TI objects to and rejects any additional or different terms you may have proposed.

Mailing Address: Texas Instruments, Post Office Box 655303, Dallas, Texas 75265
Copyright © 2023, Texas Instruments Incorporated

Looking for pricing, stock, or lifecycle information?

Click below to explore more details on WIN SOURCE:

-  [View LM5113TME/NOPB on WIN SOURCE](#)
-  [Texas Instruments](#) Information

Optimize Your Supply Chain with WIN SOURCE Solutions

-  Global Sourcing Solution
-  Obsolete Management
-  Cost Control Management
-  Shortage Management
-  Alternative Solution
-  Excess Inventory Management