





# +3V, Quad, 12-Bit Voltage-Output DAC with Serial Interface

MAX5253

## General Description

The MAX5253 combines four low-power, voltage-output, 12-bit digital-to-analog converters (DACs) and four precision output amplifiers in a space-saving, 20-pin package. In addition to the four voltage outputs, each amplifier's negative input is also available to the user. This facilitates specific gain configurations, remote sensing, and high output drive capacity, making the MAX5253 ideal for industrial-process-control applications. Other features include software shutdown, hardware shutdown lockout, an active-low reset which clears all registers and DACs to zero, a user-programmable logic output, and a serial-data output.

Each DAC has a double-buffered input organized as an input register followed by a DAC register. A 16-bit serial word loads data into each input/DAC register. The serial interface is compatible with SPI™/QSPI™ and MICROWIRE™. It allows the input and DAC registers to be updated independently or simultaneously with a single software command. The DAC registers can be simultaneously updated through the 3-wire serial interface. All logic inputs are TTL/CMOS-logic compatible.

## Applications

- Industrial Process Controls
- Automatic Test Equipment
- Digital Offset and Gain Adjustment
- Motion Control
- Remote Industrial Controls
- Microprocessor-Controlled Systems

## Features

- ◆ Four 12-Bit DACs with Configurable Output Amplifiers
- ◆ +3.0V to +3.6V Single-Supply Operation
- ◆ Low Supply Current: 0.82mA Normal Operation  
3µA Shutdown Mode
- ◆ Reference Inputs are High Impedance in Shutdown
- ◆ Available in 20-Pin SSOP
- ◆ Power-On Reset Clears all Registers and DACs to Zero
- ◆ SPI/QSPI and MICROWIRE Compatible
- ◆ Simultaneous or Independent Control of DACs Through 3-Wire Serial Interface
- ◆ User-Programmable Digital Output

## Ordering Information

PART	TEMP RANGE	PIN-PACKAGE	INL (LSB)
MAX5253ACPP	0°C to +70°C	20 Plastic DIP	±1/2
MAX5253BCPP	0°C to +70°C	20 Plastic DIP	±1
MAX5253ACAP	0°C to +70°C	20 SSOP	±1/2
MAX5253BCAP	0°C to +70°C	20 SSOP	±1

Ordering Information continued at end of data sheet.

Pin Configuration appears at end of data sheet.

## Functional Diagram

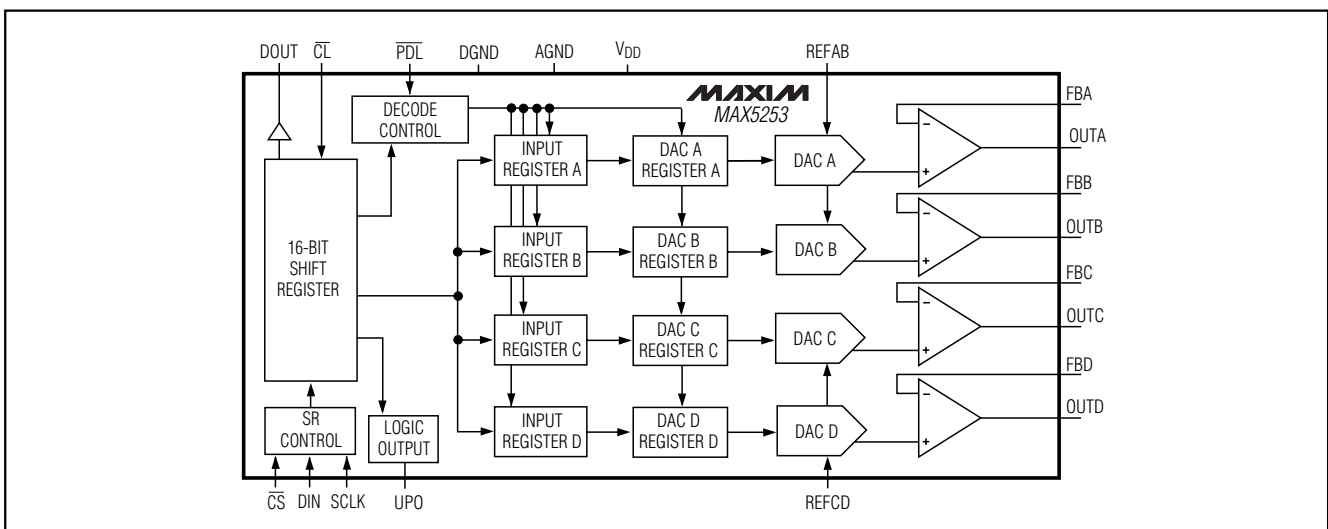

SPI and QSPI are trademarks of Motorola, Inc. MICROWIRE is a trademark of National Semiconductor Corp.



For pricing delivery, and ordering information please contact Maxim/Dallas Direct! at 1-888-629-4642, or visit Maxim's website at [www.maxim-ic.com](http://www.maxim-ic.com).

# +3V, Quad, 12-Bit Voltage-Output DAC with Serial Interface

## ABSOLUTE MAXIMUM RATINGS

V <sub>DD</sub> to AGND	-0.3V, +6V
V <sub>DD</sub> to DGND	-0.3V, +6V
AGND to DGND	±0.3V
REFAB, REFCD to AGND	-0.3V to (V <sub>DD</sub> + 0.3V)
OUT <sub>-</sub> , FB <sub>-</sub> to AGND	-0.3V to (V <sub>DD</sub> + 0.3V)
Digital Inputs to DGND	-0.3V to +6V
DOUT, UPO to DGND	-0.3V to (V <sub>DD</sub> + 0.3V)
Continuous Current into Any Pin	±20mA
Continuous Power Dissipation (T <sub>A</sub> = +70°C)	
Plastic DIP (derate 8.00mW/°C above +70°C)	640mW
SSOP (derate 8.00mW/°C above +70°C)	640mW
CERDIP (derate 11.11mW/°C above +70°C)	889mW

Operating Temperature Ranges	
MAX5253_C_P	0°C to +70°C
MAX5253_E_P	-40°C to +85°C
MAX5253BMJP	-55°C to +125°C
Storage Temperature Range	-65°C to +150°C
Lead Temperature (soldering, 10s)	+300°C

Stresses beyond those listed under "Absolute Maximum Ratings" may cause permanent damage to the device. These are stress ratings only, and functional operation of the device at these or any other conditions beyond those indicated in the operational sections of the specifications is not implied. Exposure to absolute maximum rating conditions for extended periods may affect device reliability.

## ELECTRICAL CHARACTERISTICS

(V<sub>DD</sub> = +3.0V to +3.6V, AGND = DGND = 0V, REFAB = REFCD = 1.25V, R<sub>L</sub> = 5kΩ, C<sub>L</sub> = 100pF, T<sub>A</sub> = T<sub>MIN</sub> to T<sub>MAX</sub>, unless otherwise noted. Typical values are at T<sub>A</sub> = +25°C. Output buffer connected in unity-gain configuration (Figure 9).)

PARAMETER	SYMBOL	CONDITIONS	MIN	TYP	MAX	UNITS
<b>STATIC PERFORMANCE—ANALOG SECTION</b>						
Resolution	N		12			Bits
Integral Nonlinearity (Note 1)	INL	MAX5253AC/E		±0.25	±0.5	LSB
		MAX5253BC/E			±1.0	
		MAX5253BMJP			±2.0	
Differential Nonlinearity	DNL	Guaranteed monotonic			±1.0	LSB
Offset Error	V <sub>OS</sub>				±6.0	mV
Offset-Error Tempco				6		ppm/°C
Gain Error	GE	(Note 1)			±4.0	LSB
Gain-Error Tempco				1		ppm/°C
Power-Supply Rejection Ratio	PSRR	V <sub>DD</sub> = +3.0V to +3.6V			300	μV/V
<b>MATCHING PERFORMANCE (T<sub>A</sub> = +25°C)</b>						
Gain Error	GE				±4.0	LSB
Offset Error				±1.0	±6.0	mV
Integral Nonlinearity	INL			±0.35	±1.0	LSB
<b>REFERENCE INPUT</b>						
Reference Input Range	V <sub>REF</sub>		0	V <sub>DD</sub> - 1.4		V
Reference Input Resistance	R <sub>REF</sub>	Code-dependent, minimum at code 555 hex	8			kΩ

# +3V, Quad, 12-Bit Voltage-Output DAC with Serial Interface

**MAX5253**

## ELECTRICAL CHARACTERISTICS (continued)

( $V_{DD} = +3.0V$  to  $+3.6V$ ,  $AGND = DGND = 0V$ ,  $REFAB = REFCD = 1.25V$ ,  $R_L = 5k\Omega$ ,  $C_L = 100pF$ ,  $T_A = T_{MIN}$  to  $T_{MAX}$ , unless otherwise noted. Typical values are at  $T_A = +25^\circ C$ . Output buffer connected in unity-gain configuration (Figure 9).)

PARAMETER	SYMBOL	CONDITIONS	MIN	TYP	MAX	UNITS
<b>MULTIPLYING-MODE PERFORMANCE</b>						
Reference -3dB Bandwidth		$V_{REF} = 0.67V_{P-P}$		650		kHz
Reference Feedthrough		Input code = all 0s, $V_{REF} = 1.6V_{P-P}$ at 1kHz		-84		dB
Signal-to-Noise Plus Distortion Ratio	SINAD	$V_{REF} = 1V_{P-P}$ at 25kHz		72		dB
<b>DIGITAL INPUTS</b>						
Input High Voltage	$V_{IH}$		2.0			V
Input Low Voltage	$V_{IL}$				0.8	V
Input Leakage Current	$I_{IN}$	$V_{IN} = 0V$ or $V_{DD}$		0.01	$\pm 0.1$	$\mu A$
Input Capacitance	$C_{IN}$			8		pF
<b>DIGITAL OUTPUTS</b>						
Output High Voltage	$V_{OH}$	$I_{SOURCE} = 2mA$	$V_{DD} - 0.5$			V
Output Low Voltage	$V_{OL}$	$I_{SINK} = 2mA$		0.13	0.4	V
<b>DYNAMIC PERFORMANCE</b>						
Voltage Output Slew Rate	SR			0.6		V/ $\mu s$
Output Settling Time		$T_O \pm 1/2LSB$ , $V_{STEP} = 1.25V$		16		$\mu s$
Output Voltage Swing		Rail-to-Rail® (Note 2)		0 to $V_{DD}$		V
Current into FB <sub>-</sub>				0	0.1	$\mu A$
OUT <sub>-</sub> Leakage Current in Shutdown		$R_L = \infty$		0.01	$\pm 1$	$\mu A$
Start-Up Time Exiting Shutdown Mode				20		$\mu s$
Digital Feedthrough		$\overline{CS} = V_{DD}$ , $DIN = 100kHz$		5		nV-s
Digital Crosstalk				5		nV-s
<b>POWER SUPPLIES</b>						
Supply Voltage	$V_{DD}$	(Note 3)	3.0		3.6	V
Supply Current	$I_{DD}$	(Note 4)		0.82	0.98	mA
Supply Current in Shutdown		(Note 4)		3	20	$\mu A$
Reference Current in Shutdown				0.01	$\pm 1$	$\mu A$

**Note 1:** Guaranteed from code 11 to code 4095 in unity-gain configuration.

**Note 2:** Accuracy is better than 0.5LSB for  $V_{OUT} = 6mV$  to  $V_{DD} - 80mV$ , guaranteed by PSR test on endpoints.

**Note 3:** Remains operational with supply voltage as low as +2.7V.

**Note 4:**  $R_L = \infty$ , digital inputs at DGND or  $V_{DD}$ .

*Rail-to-Rail is a registered trademark of Nippon Motorola, Ltd.*

# +3V, Quad, 12-Bit Voltage-Output DAC with Serial Interface

## TIMING CHARACTERISTICS

( $V_{DD} = +3.0V$  to  $+3.6V$ ,  $AGND = DGND = 0V$ ,  $REFAB = REFCD = 1.25V$ ,  $R_L = 5k\Omega$ ,  $C_L = 100pF$ ,  $T_A = T_{MIN}$  to  $T_{MAX}$ , unless otherwise noted. Typical values are at  $T_A = +25^\circ C$ . Output buffer connected in unity-gain configuration (Figure 9).)

PARAMETER	SYMBOL	CONDITIONS	MIN	TYP	MAX	UNITS
SCLK Clock Period	$t_{CP}$		100			ns
SCLK Pulse Width High	$t_{CH}$		40			ns
SCLK Pulse Width Low	$t_{CL}$		40			ns
$\overline{CS}$ Fall to SCLK Rise Setup Time	$t_{CSS}$		40			ns
SCLK Rise to $\overline{CS}$ Rise Hold Time	$t_{CSH}$		0			ns
DIN Setup Time	$t_{DS}$		40			ns
DIN Hold Time	$t_{DH}$		0			ns
SCLK Rise to DOUT Valid Propagation Delay	$t_{D01}$	$C_L = 200pF$			120	ns
SCLK Fall to DOUT Valid Propagation Delay	$t_{D02}$	$C_L = 200pF$			120	ns
SCLK Rise to $\overline{CS}$ Fall Delay	$t_{CS0}$		40			ns
$\overline{CS}$ Rise to SCLK Rise Hold Time	$t_{CS1}$		40			ns
$\overline{CS}$ Pulse Width High	$t_{CSW}$		100			ns

## Typical Operating Characteristics

( $V_{DD} = +3.3V$ ,  $T_A = +25^\circ C$ , unless otherwise noted.)

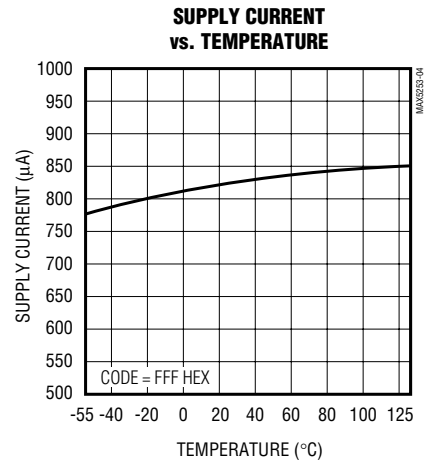
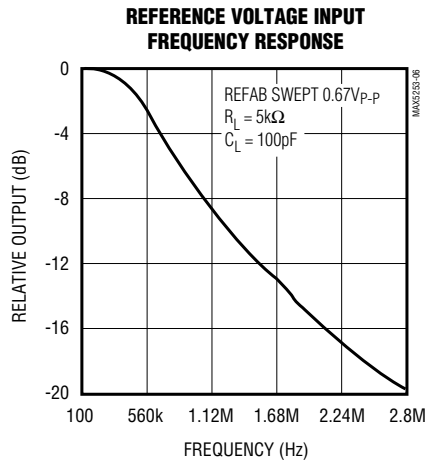
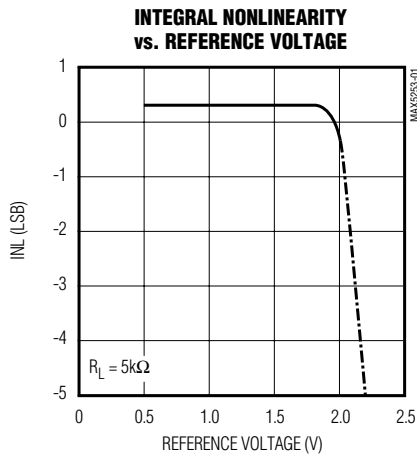

# +3V, Quad, 12-Bit Voltage-Output DAC with Serial Interface

## Typical Operating Characteristics (continued)

( $V_{DD} = +3.3V$ ,  $T_A = +25^\circ C$ , unless otherwise noted.)

MAX5253

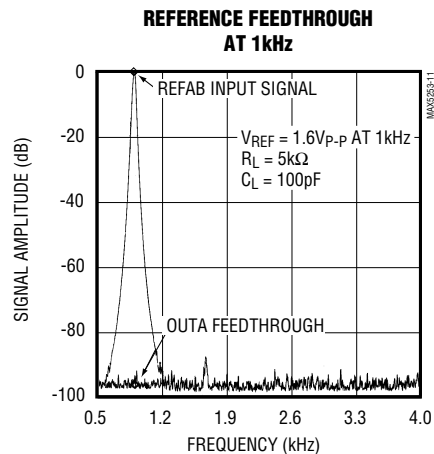
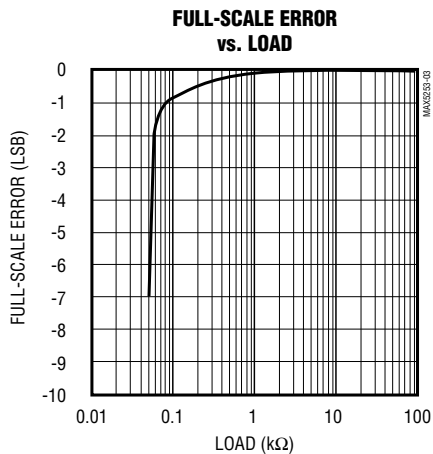
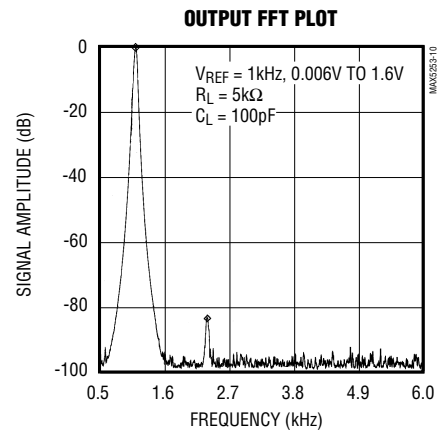
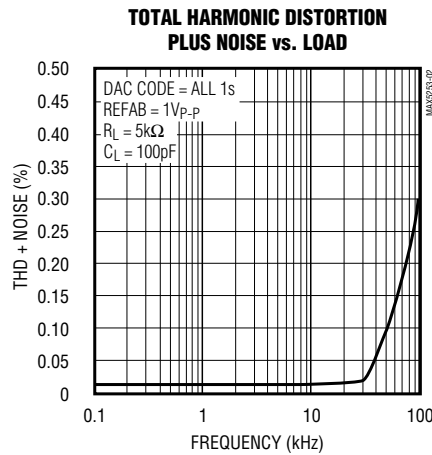
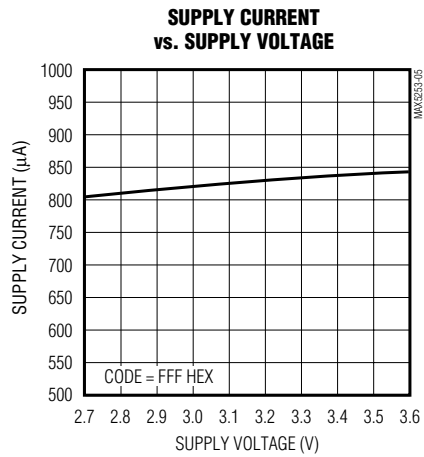

# +3V, Quad, 12-Bit Voltage-Output DAC with Serial Interface

## Typical Operating Characteristics (continued)

( $V_{DD} = +3.3V$ ,  $T_A = +25^\circ C$ , unless otherwise noted.)

MAJOR-CARRY TRANSITION

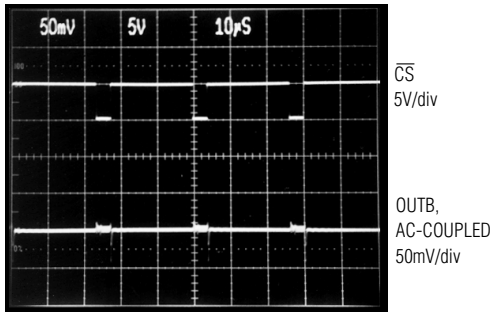

10µs/div

$V_{REF} = 1.25V$ ,  $R_L = 5k\Omega$ ,  $C_L = 100pF$

DIGITAL FEEDTHROUGH (SCLK = 100kHz)

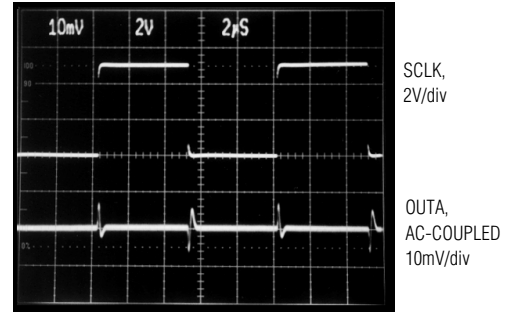

2µs/div

$V_{REF} = 1.25V$ ,  $R_L = 5k\Omega$ ,  $C_L = 100pF$   
 $\overline{CS} = \overline{PDL} = \overline{CL} = 3.3V$ ,  $DIN = 0V$   
 DAC A CODE SET TO 800 HEX

ANALOG CROSSTALK

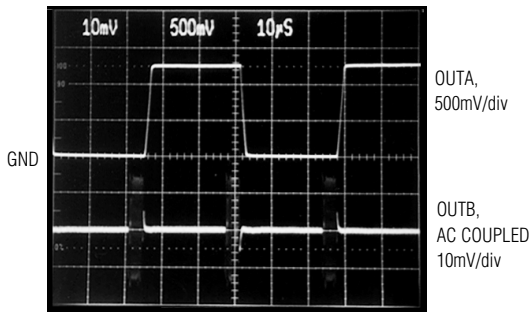

10µs/div

$V_{REF} = 1.25V$ ,  $R_L = 5k\Omega$ ,  $C_L = 100pF$   
 DAC A CODE SWITCHING FROM 00B HEX TO FFF HEX  
 DAC B CODE SET TO 800 HEX

DYNAMIC RESPONSE

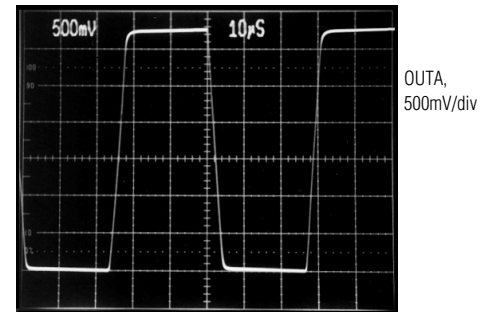

10µs/div

$V_{REF} = 1.25V$ ,  $R_L = 5k\Omega$ ,  $C_L = 100pF$   
 SWITCHING FROM CODE 000 HEX TO FB4 HEX  
 OUTPUT AMPLIFIER GAIN = +2.6

# **+3V, Quad, 12-Bit Voltage-Output DAC with Serial Interface**

## **Pin Description**

**MAX5253**

<b>PIN</b>	<b>NAME</b>	<b>FUNCTION</b>
1	AGND	Analog Ground
2	FBA	DAC A Output Amplifier Feedback
3	OUTA	DAC A Output Voltage
4	OUTB	DAC B Output Voltage
5	FBB	DAC B Output Amplifier Feedback
6	REFAB	Reference Voltage Input for DAC A and DAC B
7	$\overline{CL}$	Clears All DACs and Registers. Resets all outputs (OUT_, UPO, DOUT) to 0, active low.
8	$\overline{CS}$	Chip-Select Input. Active low.
9	DIN	Serial-Data Input
10	SCLK	Serial Clock Input
11	DGND	Digital Ground
12	DOUT	Serial-Data Output
13	UPO	User-Programmable Logic Output
14	$\overline{PDL}$	Power-Down Lockout. Active low. Locks out software shutdown if low.
15	REFCD	Reference Voltage Input for DAC C and DAC D
16	FBC	DAC C Output Amplifier Feedback
17	OUTC	DAC C Output Voltage
18	OUTD	DAC D Output Voltage
19	FBD	DAC D Output Amplifier Feedback
20	VDD	Positive Power Supply

# +3V, Quad, 12-Bit Voltage-Output DAC with Serial Interface

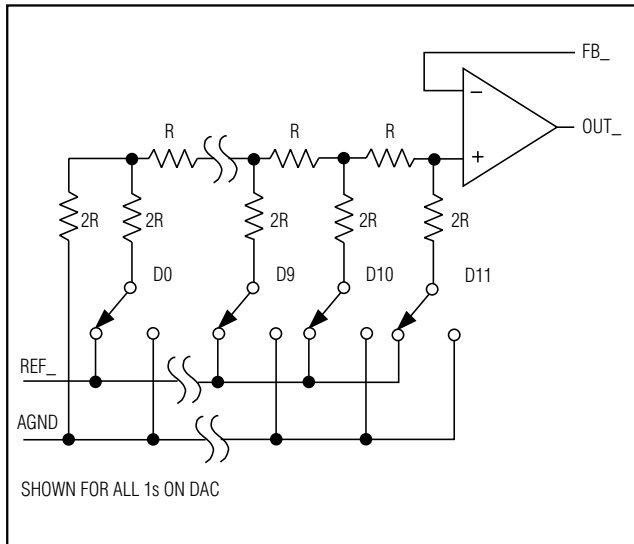

Figure 1. Simplified DAC Circuit Diagram

## Detailed Description

The MAX5253 contains four 12-bit, voltage-output digital-to-analog converters (DACs) that are easily addressed using a simple 3-wire serial interface. It includes a 16-bit data-in/data-out shift register, and each DAC has a doubled-buffered input composed of an input register and a DAC register (see *Functional Diagram*). In addition to the four voltage outputs, each amplifier's negative input is available to the user.

The DACs are inverted R-2R ladder networks that convert 12-bit digital inputs into equivalent analog output voltages in proportion to the applied reference voltage inputs. DACs A and B share the REFAB reference input, while DACs C and D share the REFCD reference input. The two reference inputs allow different full-scale output voltage ranges for each pair of DACs. Figure 1 shows a simplified circuit diagram of one of the four DACs.

### Reference Inputs

The two reference inputs accept positive DC and AC signals. The voltage at each reference input sets the full-scale output voltage for its two corresponding DACs. The reference input voltage range is 0V to ( $V_{DD} - 1.4V$ ). The output voltages ( $V_{OUT\_}$ ) are represented by a digitally programmable voltage source as:

$$V_{OUT\_} = (V_{REF} \times NB / 4096) \times \text{Gain}$$

where NB is the numeric value of the DAC's binary input code (0 to 4095),  $V_{REF}$  is the reference voltage, and Gain is the externally set voltage gain.

The impedance at each reference input is code-dependent, ranging from a low value of  $10k\Omega$  when both DACs connected to the reference have an input code of 555 hex, to a high value exceeding several gigohms (leakage current) with an input code of 000 hex. Because the input impedance at the reference pins is code-dependent, load regulation of the reference source is important.

The REFAB and REFCD reference inputs have a  $10k\Omega$  guaranteed minimum input impedance. When the two reference inputs are driven from the same source, the effective minimum impedance is  $5k\Omega$ . Driving the REFAB and REFCD pins separately improves reference accuracy.

In shutdown mode, the MAX5253's REFAB and REFCD inputs enter a high-impedance state with a typical input leakage current of  $0.01\mu A$ .

The reference input capacitance is also code dependent and typically ranges from 20pF with an input code of all 0s to 100pF with an input code of all 1s.

### Output Amplifiers

All MAX5253 DAC outputs are internally buffered by precision amplifiers with a typical slew rate of  $0.6V/\mu s$ . Access to the inverting input of each output amplifier provides the user greater flexibility in output gain setting/signal conditioning (see the *Applications Information* section).

With a full-scale transition at the MAX5253 output, the typical settling time to  $\pm 1/2LSB$  is  $16\mu s$  when loaded with  $5k\Omega$  in parallel with 100pF (loads less than  $2k\Omega$  degrade performance).

The MAX5253 output amplifier's output dynamic responses and settling performances are shown in the *Typical Operating Characteristics*.

### Shutdown Mode

The MAX5253 features a software-programmable shutdown that reduces supply current to a typical value of  $3\mu A$ . The power-down lockout (PDL) pin must be high to enable the shutdown mode. Writing 1100XXXXXXXXXXXX as the input-control word puts the MAX5253 in shutdown mode (Table 1).

# +3V, Quad, 12-Bit Voltage-Output DAC with Serial Interface

**MAX5253**

In shutdown mode, the MAX5253 output amplifiers and the reference inputs enter a high-impedance state. The serial interface remains active. Data in the input registers is retained in shutdown, allowing the MAX5253 to recall the output states prior to entering shutdown. Exit shutdown mode by either recalling the previous configuration or by updating the DACs with new data. When powering up the device or bringing it out of shutdown, allow 20µs for the outputs to stabilize.

### Serial-Interface Configurations

The MAX5253's 3-wire serial interface is compatible with both MICROWIRE (Figure 2) and SPI/QSPI (Figure 3). The serial input word consists of two address bits and two control bits followed by 12 data bits (MSB first), as shown in Figure 4. The 4-bit address/control code determines the MAX5253's response outlined in Table 1. The connection between DOUT and the serial-interface port is not necessary, but may be used for data echo. Data held in the MAX5253's shift register can be shifted out of DOUT and returned to the microprocessor (µP) for data verification.

The MAX5253's digital inputs are double buffered. Depending on the command issued through the serial interface, the input register(s) can be loaded without affecting the DAC register(s), the DAC register(s) can be loaded directly, or all four DAC registers can be updated simultaneously from the input registers (Table 1).

### Serial-Interface Description

The MAX5253 requires 16 bits of serial data. Table 1 lists the serial-interface programming commands. For certain commands, the 12 data bits are "don't cares." Data is sent MSB first and can be sent in two 8-bit packets or one 16-bit word ( $\overline{CS}$  must remain low until 16 bits are transferred). The serial data is composed of two DAC address bits (A1, A0) and two control bits (C1, C0), followed by the 12 data bits D11...D0 (Figure 4). The 4-bit address/control code determines:

- The register(s) to be updated
- The clock edge on which data is to be clocked out through the serial-data output (DOUT)
- The state of the user-programmable logic output (UPO)
- If the part is to go into shutdown mode (assuming  $\overline{PDL}$  is high)
- How the part is configured when exiting shutdown mode

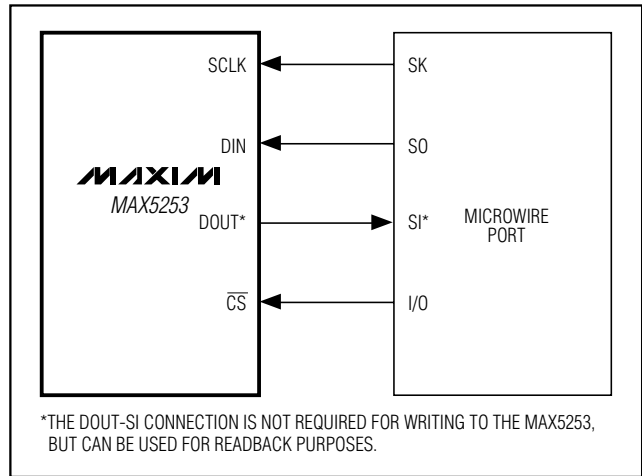

Figure 2. Connections for MICROWIRE

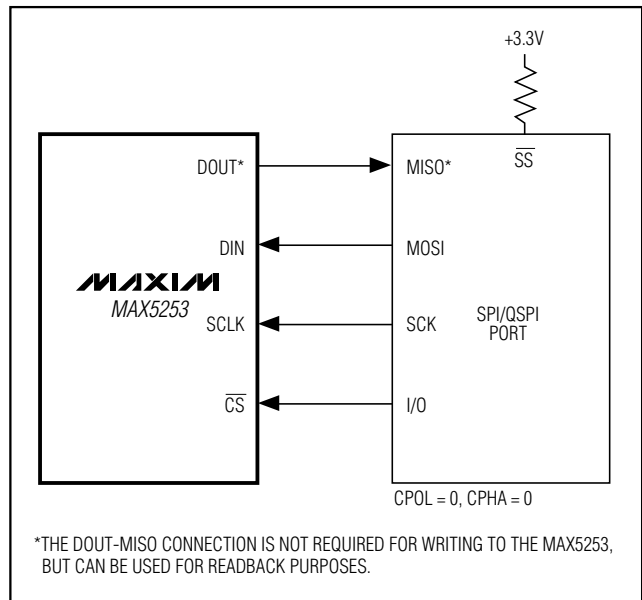

Figure 3. Connections for SPI/QSPI

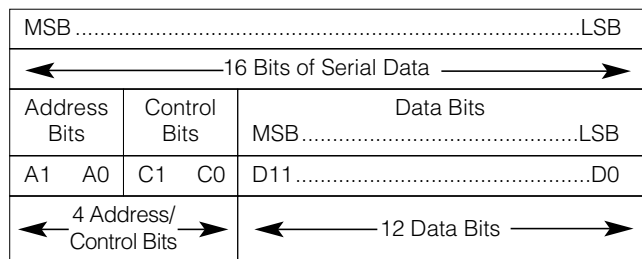

Figure 4. Serial-Data Format

# +3V, Quad, 12-Bit Voltage-Output DAC with Serial Interface

**Table 1. Serial-Interface Programming Commands**

16-BIT SERIAL WORD					FUNCTION
A1	A0	C1	C0	D11.....D0 MSB                  LSB	
0	0	0	1	12-bit DAC data	Load input register A; DAC registers unchanged.
0	1	0	1	12-bit DAC data	Load input register B; DAC registers unchanged.
1	0	0	1	12-bit DAC data	Load input register C; DAC registers unchanged.
1	1	0	1	12-bit DAC data	Load input register D; DAC registers unchanged.
0	0	1	1	12-bit DAC data	Load input register A; all DAC registers updated.
0	1	1	1	12-bit DAC data	Load input register B; all DAC registers updated.
1	0	1	1	12-bit DAC data	Load input register C; all DAC registers updated.
1	1	1	1	12-bit DAC data	Load input register D; all DAC registers updated.
0	1	0	0	XXXXXXXXXXXX	Update all DAC registers from their respective input registers (exit shutdown mode).
1	0	0	0	12-bit DAC data	Load all DAC registers from shift register (exit shutdown mode).
1	1	0	0	XXXXXXXXXXXX	Enter shutdown mode (provided $\overline{\text{PDL}} = 1$ )
0	0	1	0	XXXXXXXXXXXX	UPO goes low (default)
0	1	1	0	XXXXXXXXXXXX	UPO goes high
0	0	0	0	XXXXXXXXXXXX	No operation (NOP) to DAC registers
1	1	1	0	XXXXXXXXXXXX	Mode 1, DOUT clocked out on SCLK's rising edge. All DAC registers updated.
1	0	1	0	XXXXXXXXXXXX	Mode 0, DOUT clocked out on SCLK's falling edge. All DAC registers updated (default).

"X" = Don't care

Figure 5 shows the serial-interface timing requirements. The chip-select pin ( $\overline{\text{CS}}$ ) must be low to enable the DAC's serial interface. When  $\overline{\text{CS}}$  is high, the interface control circuitry is disabled.  $\overline{\text{CS}}$  must go low at least  $t_{\text{CSS}}$  before the rising serial clock (SCLK) edge to properly clock in the first bit. When  $\overline{\text{CS}}$  is low, data is clocked into the internal shift register through the serial-data input pin (DIN) on SCLK's rising edge. The maximum guaranteed clock frequency is 10MHz. Data is latched into the appropriate MAX5253 input/DAC registers on  $\overline{\text{CS}}$ 's rising edge.

The programming command Load-All-DACs-From-Shift-Register allows all input and DAC registers to be simultaneously loaded with the same digital code from the input shift register. The no operation (NOP) command leaves the register contents unaffected and is useful when the MAX5253 is configured in a daisy chain (see the *Daisy Chaining Devices* section). The command to

change the clock edge on which serial data is shifted out of DOUT also loads data from all input registers to their respective DAC registers.

### Serial-Data Output (DOUT)

The serial-data output, DOUT, is the internal shift register's output. The MAX5253 can be programmed so that data is clocked out of DOUT on SCLK's rising edge (Mode 1) or falling edge (Mode 0). In Mode 0, output data at DOUT lags input data at DIN by 16.5 clock cycles, maintaining compatibility with Microwire, SPI/QSPI, and other serial interfaces. In Mode 1, output data lags input data by 16 clock cycles. On power-up, DOUT defaults to Mode 0 timing.

### User-Programmable Logic Output (UPO)

The user-programmable logic output, UPO, allows an external device to be controlled through the MAX5253 serial interface (Table 1).

# +3V, Quad, 12-Bit Voltage-Output DAC with Serial Interface

MAX5253

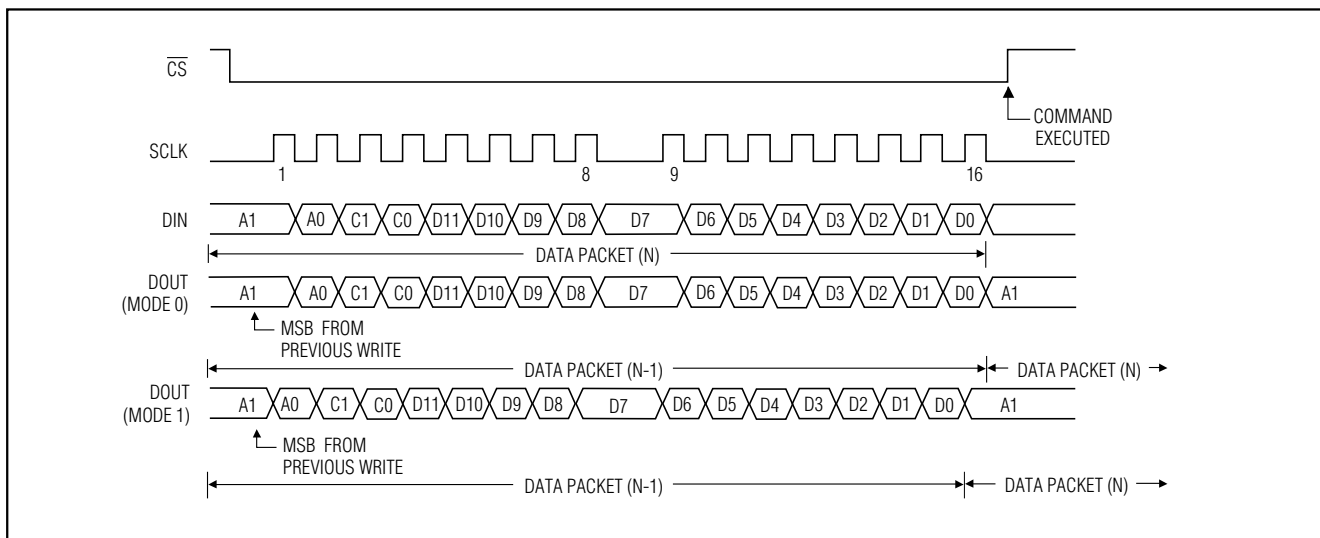

Figure 5. Serial-Interface Timing Diagram

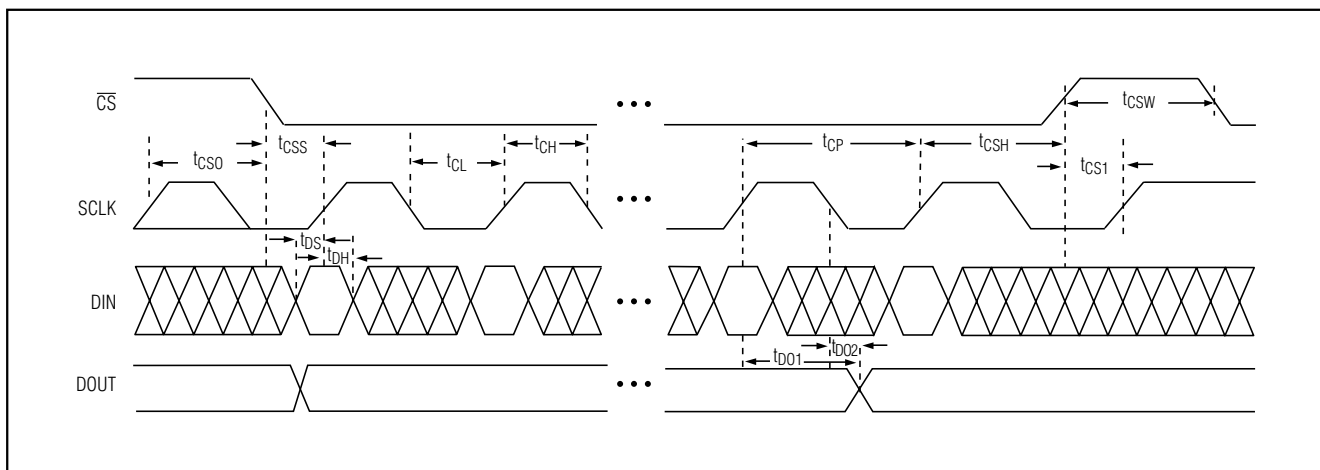

Figure 6. Detailed Serial-Interface Timing Diagram

## Power-Down Lockout (PDL)

The power-down lockout pin  $\overline{\text{PDL}}$  disables software shutdown when low. When in shutdown, transitioning  $\overline{\text{PDL}}$  from high to low wakes up the part with the output set to the state prior to shutdown.  $\overline{\text{PDL}}$  could also be used to asynchronously wake up the device.

## Daisy-Chaining Devices

Any number of MAX5253s can be daisy chained by connecting the DOUT pin of one device to the DIN pin of the following device in the chain (Figure 7).

Since the MAX5253's DOUT pin has an internal active pull-up, the DOUT sink/source capability determines the time required to discharge/charge a capacitive load. Refer to the serial-data-out  $\text{VOH}$  and  $\text{VOL}$  specifications in the *Electrical Characteristics*.

Figure 8 shows an alternate method of connecting several MAX5253s. In this configuration, the data bus is common to all devices; data is not shifted through a daisy chain. More I/O lines are required in this configuration because a dedicated chip-select input (CS) is required for each IC.

# **+3V, Quad, 12-Bit Voltage-Output DAC with Serial Interface**

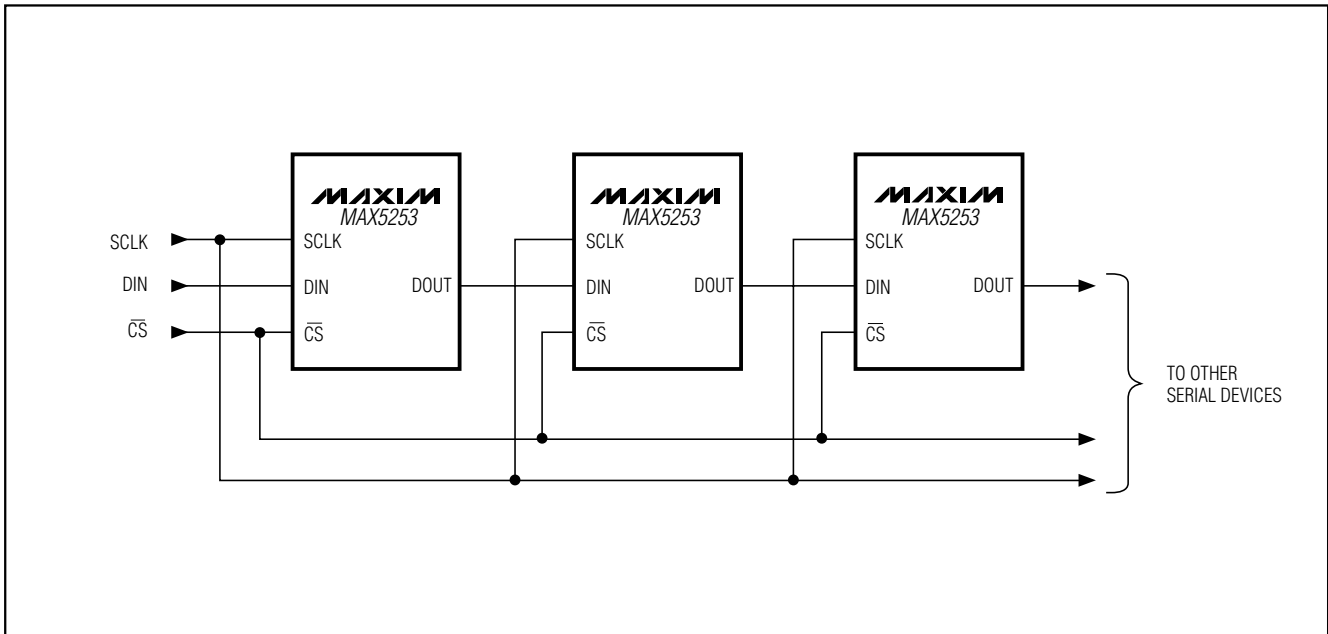

Figure 7. Daisy-Chaining MAX5253s

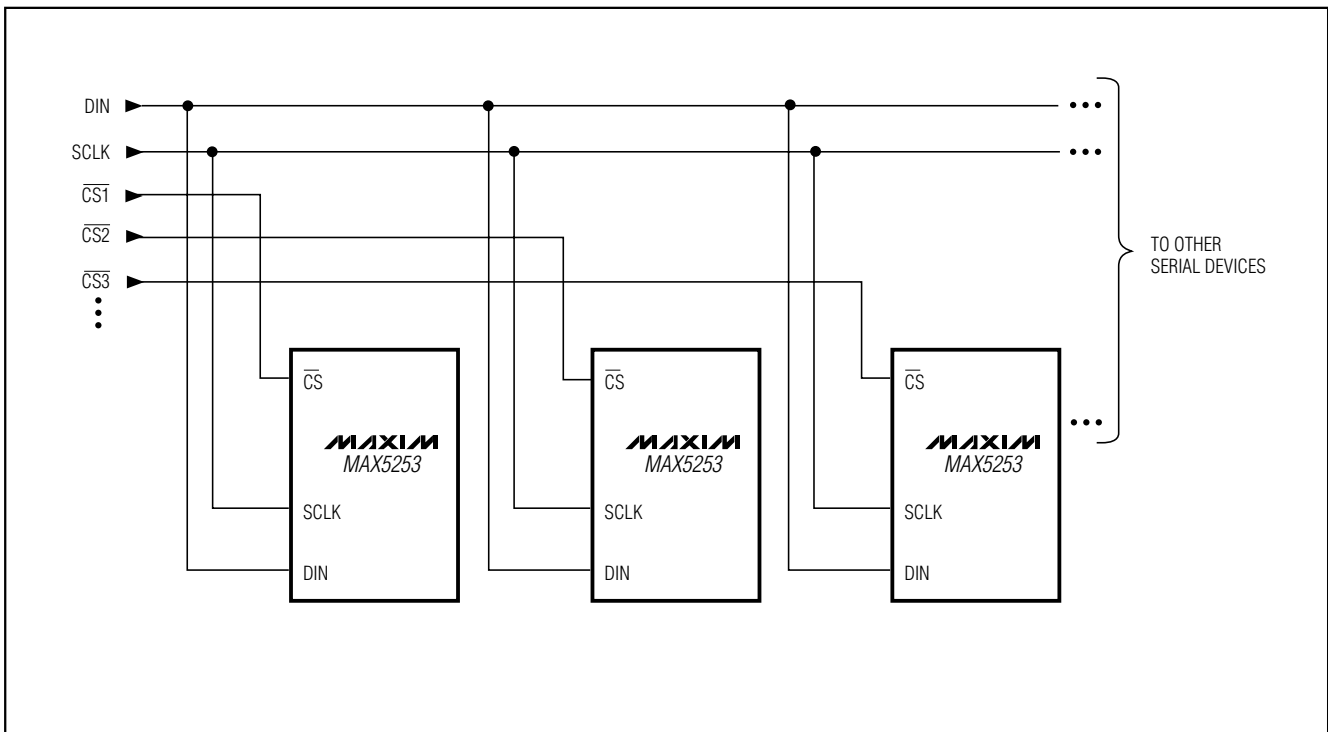

Figure 8. Multiple MAX5253s Sharing a Common DIN Line

# +3V, Quad, 12-Bit Voltage-Output DAC with Serial Interface

## Applications Information

### Unipolar Output

For a unipolar output, the output voltages and the reference inputs have the same polarity. Figure 9 shows the MAX5253 unipolar output circuit, which is also the typical operating circuit. Table 2 lists the unipolar output codes.

For rail-to-rail outputs, see Figure 10. This circuit shows the MAX5253 with the output amplifiers configured with a closed-loop gain of +2.6 to provide 0V to 3.25V full-scale range when a 1.25V reference is used.

**Table 2. Unipolar Code Table**

DAC CONTENTS		ANALOG OUTPUT
MSB	LSB	
1111	1111 1111	$+V_{REF} \left( \frac{4095}{4096} \right)$
1000	0000 0001	$+V_{REF} \left( \frac{2049}{4096} \right)$
1000	0000 0000	$+V_{REF} \left( \frac{2048}{4096} \right) = \frac{+V_{REF}}{2}$
0111	1111 1111	$+V_{REF} \left( \frac{2047}{4096} \right)$
0000	0000 0001	$+V_{REF} \left( \frac{1}{4096} \right)$
0000	0000 0000	0V

**Table 3. Bipolar Code Table**

DAC CONTENTS		ANALOG OUTPUT
MSB	LSB	
1111	1111 1111	$+V_{REF} \left( \frac{2047}{2048} \right)$
1000	0000 0001	$+V_{REF} \left( \frac{1}{2048} \right)$
1000	0000 0000	0V
0111	1111 1111	$-V_{REF} \left( \frac{1}{2048} \right)$
0000	0000 0001	$-V_{REF} \left( \frac{2047}{2048} \right)$
0000	0000 0000	$-V_{REF} \left( \frac{2048}{2048} \right) = -V_{REF}$

### Bipolar Output

The MAX5253 outputs can be configured for bipolar operation using Figure 11's circuit.

$$V_{OUT} = V_{REF} [(2NB / 4096) - 1]$$

where NB is the numeric value of the DAC's binary input code. Table 3 shows digital codes (offset binary) and corresponding output voltages for Figure 11's circuit.

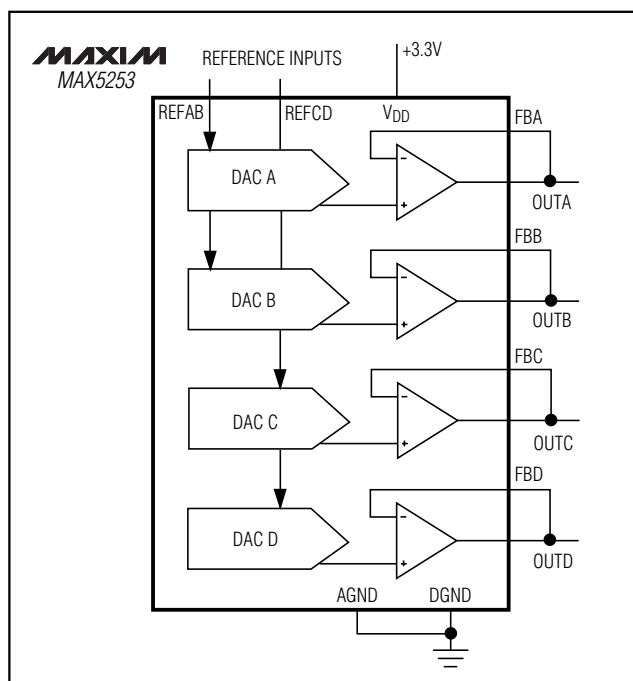

Figure 9. Unipolar Output Circuit

# +3V, Quad, 12-Bit Voltage-Output DAC with Serial Interface

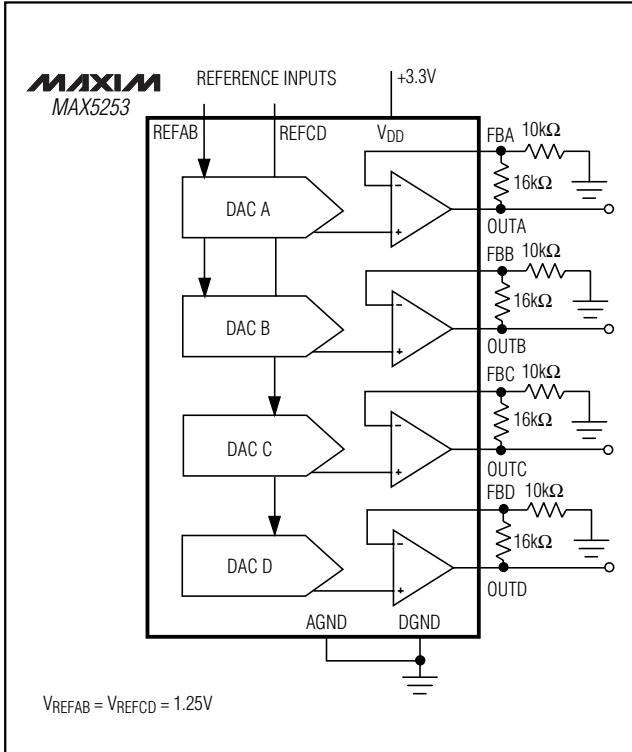

Figure 10. Unipolar Rail-to-Rail Output Circuit

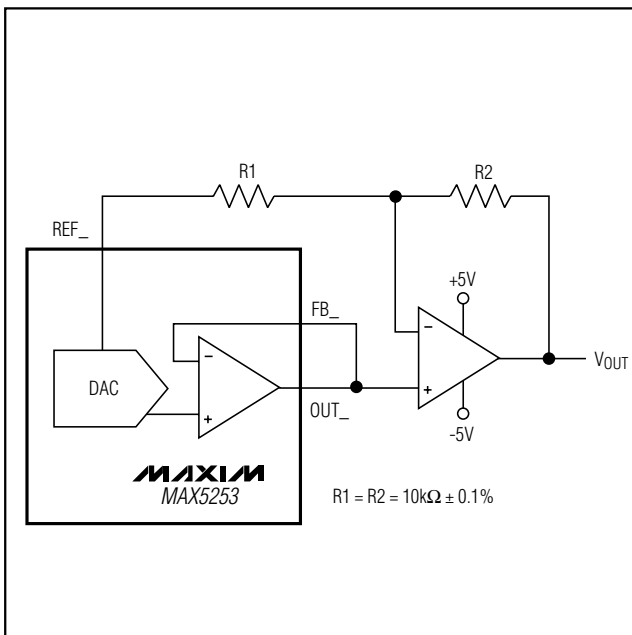

Figure 11. Bipolar Output Circuit

## Using an AC Reference

In applications where the reference has AC signal components, the MAX5253 has multiplying capability within the reference input range specifications. Figure 12 shows a technique for applying a sine-wave signal to the reference input where the AC signal is offset before being applied to REFAB/REFCD. The reference voltage must never be more negative than DGND.

The MAX5253's total harmonic distortion plus noise (THD + N) is typically less than -72dB, given a 1V signal swing and input frequencies up to 25kHz. The typical -3dB frequency is 650kHz, as shown in the *Typical Operating Characteristics* graphs.

## Digitally Programmable Current Source

The circuit of Figure 13 places an NPN transistor (2N3904 or similar) within the op-amp feedback loop to implement a digitally programmable, unidirectional current source. This circuit can be used to drive 4mA to 20mA current loops, which are commonly used in industrial-control applications. The output current is calculated with the following equation:

$$I_{OUT} = (V_{REF} / R) \times (NB / 4096)$$

where NB is the numeric value of the DAC's binary input code and R is the sense resistor shown in Figure 13.

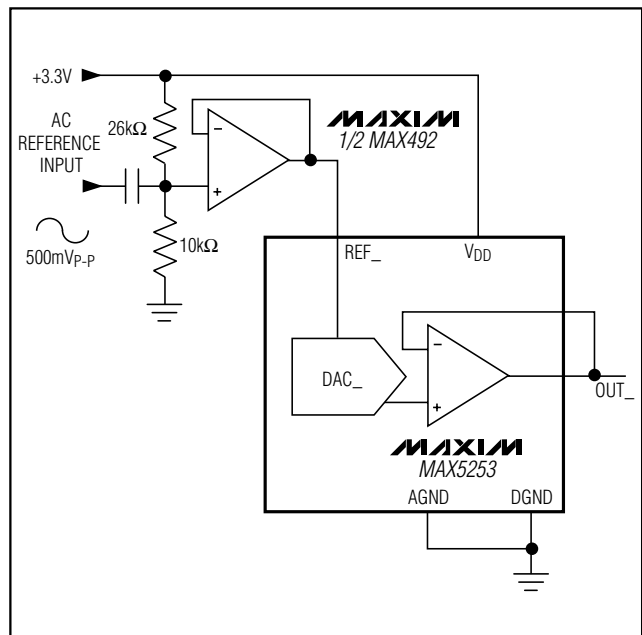

Figure 12. AC Reference Input Circuit

# +3V, Quad, 12-Bit Voltage-Output DAC with Serial Interface

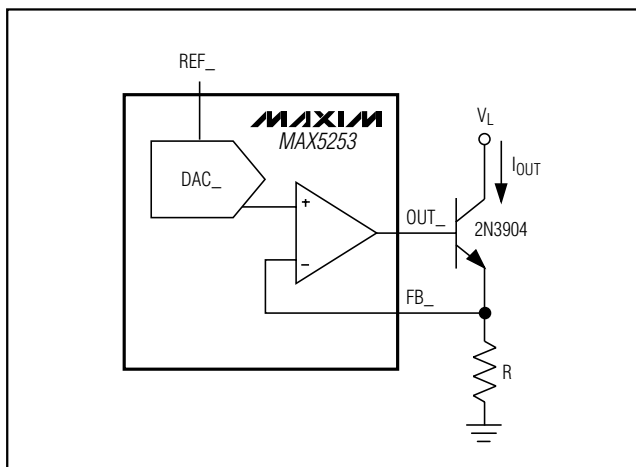

Figure 13. Digitally Programmable Current Source

## Power-Supply Considerations

On power-up, all input and DAC registers are cleared (set to zero code) and DOUT is in Mode 0 (serial data is shifted out of DOUT on the clock's falling edge).

For rated MAX5253 performance, limit REFAB/REFCD to less than 1.4V below V<sub>DD</sub>. Bypass V<sub>DD</sub> with a 4.7μF capacitor in parallel with a 0.1μF capacitor to AGND. Use short lead lengths and place the bypass capacitors as close to the supply pins as possible.

## Grounding and Layout Considerations

Digital or AC transient signals between AGND and DGND can create noise at the analog outputs. Tie AGND and DGND together at the DAC, then tie this point to the highest-quality ground available.

Good printed circuit board ground layout minimizes crosstalk between DAC outputs, reference inputs, and digital inputs. Reduce crosstalk by keeping analog lines away from digital lines. Wire-wrapped boards are not recommended.

## Pin Configuration

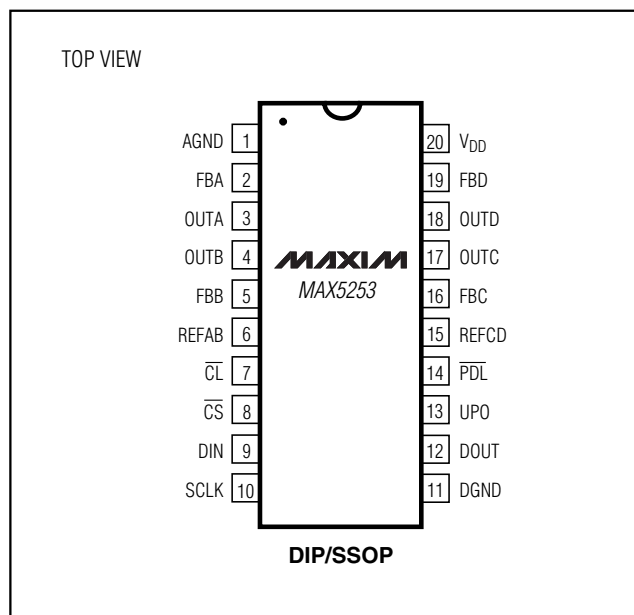

**MAX5253**

# +3V, Quad, 12-Bit Voltage-Output DAC with Serial Interface

## Ordering Information (continued)

PART	TEMP RANGE	PIN-PACKAGE	INL (LSBs)
MAX5253BC/D	0°C to +70°C	Dice*	±1
MAX5253AEPP	-40°C to +85°C	20 Plastic DIP	±1/2
MAX5253BEPP	-40°C to +85°C	20 Plastic DIP	±1
MAX5253AEAP	-40°C to +85°C	20 SSOP	±1/2
MAX5253BEAP	-40°C to +85°C	20 SSOP	±1
MAX5253BMJP	-55°C to +125°C	20 CERDIP**	±2

\* Dice are specified at  $T_A = +25^\circ\text{C}$ , DC parameters only.  
 \*\*Contact factory for availability and processing to MIL-STD-883.

## Chip Information

TRANSISTOR COUNT: 4337

## Package Information

(The package drawing(s) in this data sheet may not reflect the most current specifications. For the latest package outline information go to [www.maxim-ic.com/packages](http://www.maxim-ic.com/packages).)

DIM	INCHES		MILLIMETERS	
	MIN	MAX	MIN	MAX
A	0.068	0.078	1.73	1.99
A1	0.002	0.008	0.05	0.21
B	0.010	0.015	0.25	0.38
C	0.004	0.008	0.09	0.20
D	SEE VARIATIONS			
E	0.205	0.209	5.20	5.38
e	0.0256 BSC		0.65 BSC	
H	0.301	0.311	7.65	7.90
L	0.025	0.037	0.63	0.95
$\alpha$	0°	8°	0°	8°

DIM	PINS	INCHES		MILLIMETERS	
		MIN	MAX	MIN	MAX
D	14	0.239	0.249	6.07	6.33
D	16	0.239	0.249	6.07	6.33
D	20	0.278	0.289	7.07	7.33
D	24	0.317	0.328	8.07	8.33
D	28	0.397	0.407	10.07	10.33

**SSOP SHRINK SMALL-OUTLINE PACKAGE**

21-0056A

Maxim cannot assume responsibility for use of any circuitry other than circuitry entirely embodied in a Maxim product. No circuit patent licenses are implied. Maxim reserves the right to change the circuitry and specifications without notice at any time.

16 **Maxim Integrated Products, 120 San Gabriel Drive, Sunnyvale, CA 94086 408-737-7600**

## Looking for pricing, stock, or lifecycle information?

Click below to explore more details on WIN SOURCE:

 [View MAX5253BCPP on WIN SOURCE](#)

 [Maxim Integrated](#) Information

## Optimize Your Supply Chain with WIN SOURCE Solutions

-  Global Sourcing Solution
-  Obsolete Management
-  Cost Control Management
-  Shortage Management
-  Alternative Solution
-  Excess Inventory Management