



**THE DATASHEET OF
CYV15G0203TB-BGC**





Features

- Second-generation HOTLink® technology
- Compliant to SMPTE 292M and SMPTE 259M video standards
- Dual-channel video serializer
 - 195- to 1500-Mbps serial data signaling rate
 - Simultaneous operation at different signaling rates
- Supports half-rate and full-rate clocking
- Internal phase-locked loops (PLLs) with no external PLL components
- Redundant differential PECL-compatible serial outputs per channel
 - No external bias resistors required
 - Signaling-rate controlled edge-rates
 - Internal source termination
- Synchronous LVTTTL parallel interface
- JTAG boundary scan
- Built-In Self-Test (BIST) for at-speed link testing
- Low-power 1.4W @ 3.3V typical
- Single 3.3V supply
- Thermally enhanced BGA
- Pb-Free package option available
- 0.25µ BiCMOS technology

Functional Description

The CYV15G0203TB Independent Clock Dual HOTLink II™ Serializer is a point-to-point or point-to-multipoint communications building block enabling transfer of data over a variety of high-speed serial links including SMPTE 292M and SMPTE 259M video applications. It supports signaling rates in the range of 195 to 1500 Mbps per serial link. The two channels are independent and can simultaneously operate at different rates. Each channel accepts 10-bit parallel characters in an Input Register and converts them to serial data. *Figure 1* illustrates typical connections between independent video coprocessors and corresponding CYV15G0203TB Serializer and CYV15G0204RB Reclocking Deserializer chips.

The CYV15G0203TB satisfies the SMPTE-259M and SMPTE-292M compliance as per SMPTE EG34-1999 Pathological Test Requirements.

As a second-generation HOTLink device, the CYV15G0203TB extends the HOTLink family with enhanced levels of integration and faster data rates, while maintaining serial-link compatibility (data, and BIST) with other HOTLink devices. Each channel of the CYV15G0203TB Dual HOTLink II device accepts scrambled 10-bit transmission characters. These characters are serialized and output from dual Positive ECL (PECL) compatible differential transmission-line drivers at a bit-rate of either 10- or 20-times the input reference clock for that channel.

Each channel contains an independent BIST pattern generator. This BIST hardware allows at-speed testing of the high-speed serial data paths in each transmit section of this device, each receive section of a connected HOTLink II device, and across the interconnecting links.

The CYV15G0203TB is ideal for SMPTE applications where different data rates and serial interface standards are necessary for each channel. Some applications include multi-format routers, switchers, format converters, and cameras.

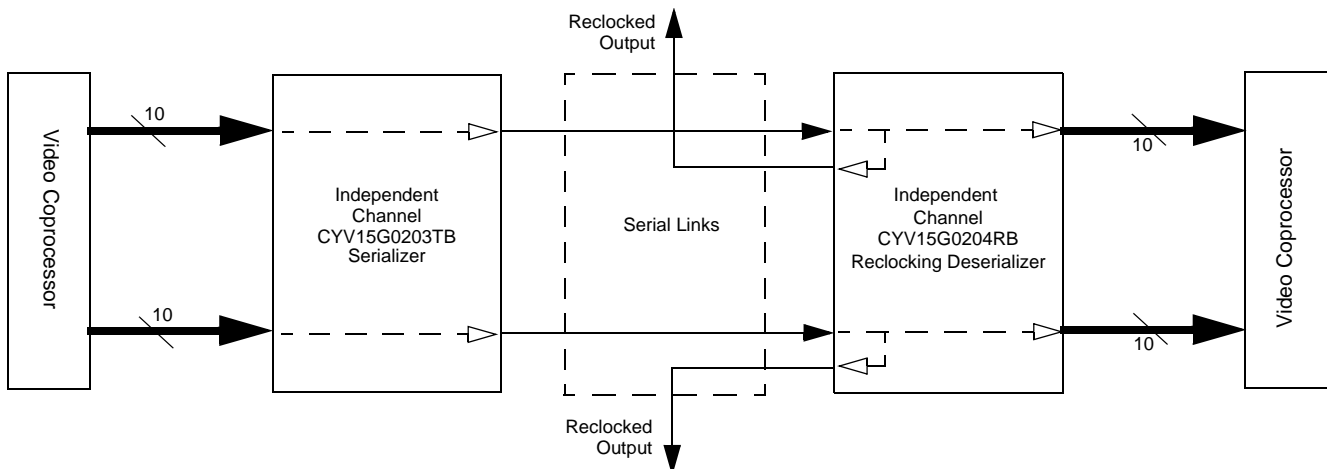
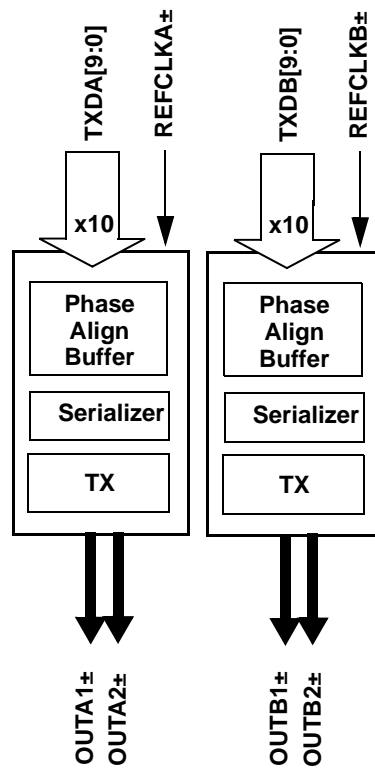
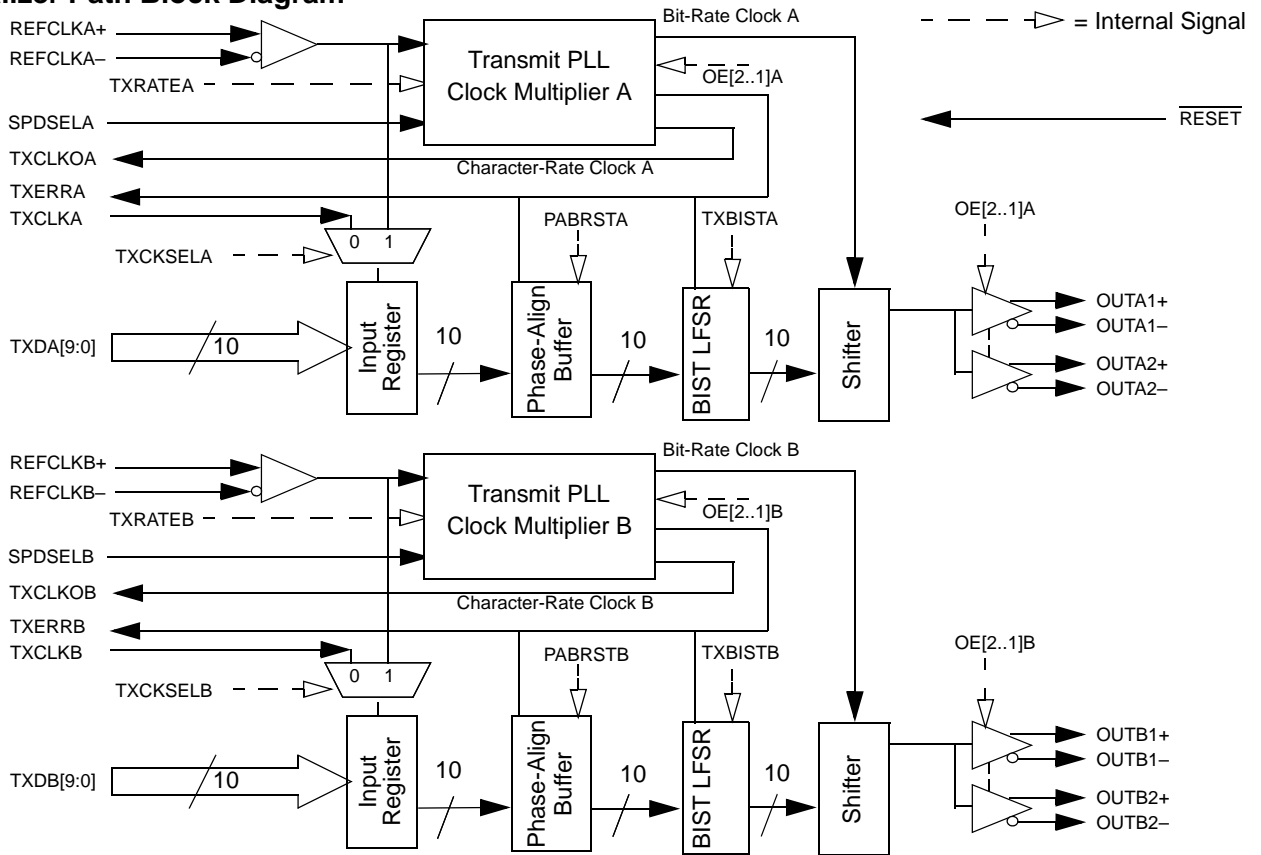
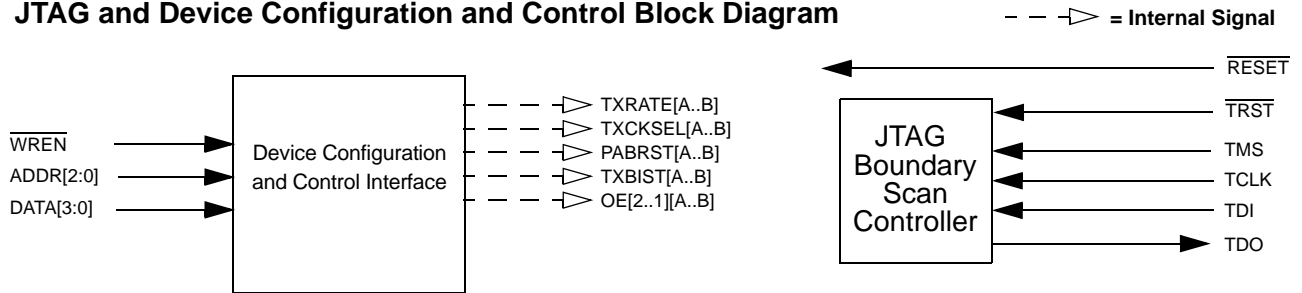

Figure 1. HOTLink II™ System Connections

CYV15G0203TB Serializer Logic Block Diagram



Serializer Path Block Diagram

JTAG and Device Configuration and Control Block Diagram

Pin Configuration (Top View)^[1]

	1	2	3	4	5	6	7	8	9	10	11	12	13	14	15	16	17	18	19	20
A	NC	NC	NC	NC	V _{CC}	NC	OUT B1-	GND	GND	OUT B2-	GND	OUT A1-	GND	GND	OUT A2-	V _{CC}	V _{CC}	NC	V _{CC}	NC
B	V _{CC}	NC	V _{CC}	NC	V _{CC}	V _{CC}	OUT B1+	GND	NC	OUT B2+	NC	OUT A1+	GND	NC	OUT A2+	V _{CC}	NC	NC	NC	NC
C	TDI	TMS	V _{CC}	V _{CC}	V _{CC}	NC	NC	GND	NC	NC	DATA [2]	DATA [0]	GND	NC	SPD SELB	V _{CC}	NC	$\overline{\text{TRST}}$	GND	TDO
D	TCLK	$\overline{\text{RESET}}$	V _{CC}	V _{CC}	V _{CC}	V _{CC}	NC	GND	GND	DATA [3]	DATA [1]	GND	GND	GND	NC	V _{CC}	NC	NC	SCAN EN2	TMEN3
E	V _{CC}	V _{CC}	V _{CC}	V _{CC}													V _{CC}	V _{CC}	V _{CC}	V _{CC}
F	NC	NC	V _{CC}	NC													NC	NC	NC	NC
G	GND	$\overline{\text{WREN}}$	GND	GND													NC	NC	SPD SELA	NC
H	GND	GND	GND	GND													GND	GND	GND	GND
J	GND	GND	GND	GND													NC	NC	NC	NC
K	NC	NC	GND	GND													NC	NC	NC	NC
L	NC	NC	NC	GND													NC	NC	NC	GND
M	NC	NC	NC	NC													NC	NC	NC	GND
N	GND	GND	GND	GND													GND	GND	GND	GND
P	NC	NC	NC	NC													GND	GND	GND	GND
R	NC	NC	NC	NC													V _{CC}	V _{CC}	V _{CC}	V _{CC}
T	V _{CC}	V _{CC}	V _{CC}	V _{CC}													V _{CC}	V _{CC}	V _{CC}	V _{CC}
U	TX DB[0]	TX DB[1]	TX DB[2]	TX DB[9]	V _{CC}	NC	NC	GND	TX DA[9]	ADDR [0]	REF CLKB-	TX DA[1]	GND	TX DA[4]	TX DA[8]	V _{CC}	NC	V _{CC}	NC	NC
V	TX DB[3]	TX DB[4]	TX DB[8]	NC	V _{CC}	NC	NC	GND	NC	GND	REF CLKB+	TX CLKOA	GND	TX DA[3]	TX DA[7]	V _{CC}	NC	NC	NC	NC
W	TX DB[5]	TX DB[7]	NC	NC	V _{CC}	NC	NC	GND	ADDR [2]	ADDR [1]	NC	TX ERRA	GND	TX DA[2]	TX DA[6]	V _{CC}	NC	REF CLKA+	NC	NC
Y	TX DB[6]	TX CLKB	NC	NC	V _{CC}	NC	NC	GND	TX CLKOB	NC	TX CLKA	NC	GND	TX DA[0]	TX DA[5]	V _{CC}	TX ERRA	REF CLKA-	NC	NC

Note:

1. NC = Do not connect.

Pin Configuration (Bottom View)^[1]

	20	19	18	17	16	15	14	13	12	11	10	9	8	7	6	5	4	3	2	1
A	NC	V _{CC}	NC	V _{CC}	V _{CC}	OUT A2-	GND	GND	OUT A1-	GND	OUT B2-	GND	GND	OUT B1-	NC	V _{CC}	NC	NC	NC	NC
B	NC	NC	NC	NC	V _{CC}	OUT A2+	NC	GND	OUT A1+	NC	OUT B2+	NC	GND	OUT B1+	V _{CC}	V _{CC}	NC	V _{CC}	NC	V _{CC}
C	TDO	GND	$\overline{\text{TRST}}$	NC	V _{CC}	SPD SELB	NC	GND	DATA [0]	DATA [2]	NC	NC	GND	NC	NC	V _{CC}	V _{CC}	V _{CC}	TMS	TDI
D	TMEN3	SCAN EN2	NC	NC	V _{CC}	NC	GND	GND	GND	DATA [1]	DATA [3]	GND	GND	NC	V _{CC}	V _{CC}	V _{CC}	V _{CC}	$\overline{\text{RESET}}$	TCLK
E	V _{CC}	V _{CC}	V _{CC}	V _{CC}													V _{CC}	V _{CC}	V _{CC}	V _{CC}
F	NC	NC	NC	NC													NC	V _{CC}	NC	NC
G	NC	SPD SELA	NC	NC													GND	GND	$\overline{\text{WREN}}$	GND
H	GND	GND	GND	GND													GND	GND	GND	GND
J	NC	NC	NC	NC													GND	GND	GND	GND
K	NC	NC	NC	NC													GND	GND	NC	NC
L	GND	NC	NC	NC													GND	NC	NC	NC
M	GND	NC	NC	NC													NC	NC	NC	NC
N	GND	GND	GND	GND													GND	GND	GND	GND
P	GND	GND	GND	GND													NC	NC	NC	NC
R	V _{CC}	V _{CC}	V _{CC}	V _{CC}													NC	NC	NC	NC
T	V _{CC}	V _{CC}	V _{CC}	V _{CC}													V _{CC}	V _{CC}	V _{CC}	V _{CC}
U	NC	NC	V _{CC}	NC	V _{CC}	TX DA[8]	TX DA[4]	GND	TX DA[1]	REF CLKB-	ADDR [0]	TX DA[9]	GND	NC	NC	V _{CC}	TX DB[9]	TX DB[2]	TX DB[1]	TX DB[0]
V	NC	NC	NC	NC	V _{CC}	TX DA[7]	TX DA[3]	GND	TX CLKOA	REF CLKB+	GND	NC	GND	NC	NC	V _{CC}	NC	TX DB[8]	TX DB[4]	TX DB[3]
W	NC	NC	REF CLKA+	NC	V _{CC}	TX DA[6]	TX DA[2]	GND	TX ERRA	NC	ADDR [1]	ADDR [2]	GND	NC	NC	V _{CC}	NC	NC	TX DB[7]	TX DB[5]
Y	NC	NC	REF CLKA-	TX ERRB	V _{CC}	TX DA[5]	TX DA[0]	GND	NC	TX CLKA	NC	TX CLKOB	GND	NC	NC	V _{CC}	NC	NC	TX CLKB	TX DB[6]

Pin Definitions
CYV15G0203TB Dual HOTLink II Serializer

Name	I/O Characteristics	Signal Description
Transmit Path Data and Status Signals		
TXDA[9:0] TXDB[9:0]	LVTTL Input, synchronous, sampled by the associated TXCLKx [↑] or REFCLKx [↑] [2]	Transmit Data Inputs. TXDx[9:0] data inputs are captured on the rising edge of the transmit interface clock. The transmit interface clock is selected by the TXCKSELx latch via the device configuration interface.
TXERRA TXERRB	LVTTL Output, synchronous to REFCLKx [↑] [3], asynchronous to transmit channel enable / disable, asynchronous to loss or return of REFCLKx [±]	Transmit Path Error. TXERRx is asserted HIGH to indicate detection of a transmit Phase-Align Buffer underflow or overflow. If an underflow or overflow condition is detected, TXERRx, for the channel in error, is asserted HIGH and remains asserted until the transmit Phase-Align Buffer is re-centered with the PABRSTx latch via the device configuration interface. When TXBISTx = 0, the BIST progress is presented on the associated TXERRx output. The TXERRx signal pulses HIGH for one transmit-character clock period to indicate a pass through the BIST sequence once every 511 character times. TXERRx is also asserted HIGH, when any of the following conditions is true: <ul style="list-style-type: none"> • The TXPLL for the associated channel is powered down. This occurs when OE2x and OE1x for a given channel are both disabled by setting OE2x = 0 and OE1x = 0. • The absence of the REFCLKx[±] signal.
Transmit Path Clock Signals		
REFCLKA [±] REFCLKB [±]	Differential LVPECL or single-ended LVTTL input clock	Reference Clock. REFCLKx [±] clock inputs are used as the timing references for the associated transmit PLL. These input clocks may also be selected to clock the transmit parallel interface. When driven by a single-ended LVCMOS or LVTTL clock source, connect the clock source to either the true or complement REFCLKx input, and leave the alternate REFCLKx input open (floating). When driven by an LVPECL clock source, the clock must be a differential clock, using both inputs.
TXCLKA TXCLKB	LVTTL Clock Input, internal pull-down	Transmit Path Input Clock. When configuration latch TXCKSELx = 0, the associated TXCLKx input is selected as the character-rate input clock for the TXDB[9:0] input. In this mode, the TXCLKx input must be frequency-coherent to its associated TXCLKOx output clock, but may be offset in phase by any amount. Once initialized, TXCLKx is allowed to drift in phase as much as ±180 degrees. If the input phase of TXCLKx drifts beyond the handling capacity of the Phase Align Buffer, TXERRx is asserted to indicate the loss of data, and remains asserted until the Phase Align Buffer is initialized. The phase of the TXCLKx input clock relative to its associated REFCLKx [±] is initialized when the configuration latch PABRSTx is written as 0. When the associated TXERRx is deasserted, the Phase Align Buffer is initialized and input characters are correctly captured.
TXCLKOA TXCLKOB	LVTTL Output	Transmit Clock Output. TXCLKOx output clock is synthesized by each channel's transmit PLL and operates synchronous to the internal transmit character clock. TXCLKOx operates at either the same frequency as REFCLKx [±] (TXRATEx = 0), or at twice the frequency of REFCLKx [±] (TXRATEx = 1). The transmit clock outputs have no fixed phase relationship to REFCLKx [±] .
Device Control Signals		
RESET	LVTTL Input, asynchronous, internal pull-up	Asynchronous Device Reset. RESET initializes all state machines, counters, and configuration latches in the device to a known state. RESET must be asserted LOW for a minimum pulse width. When the reset is removed, all state machines, counters and configuration latches are at an initial state. See <i>Table 2</i> for the initialize values of the device configuration latches.

Notes:

2. When REFCLKx[±] is configured for half-rate operation, these inputs are sampled relative to both the rising and falling edges of the associated REFCLKx[±].
3. When REFCLKx[±] is configured for half-rate operation, these outputs are presented relative to both the rising and falling edges of the associated REFCLKx[±].

Pin Definitions (continued)
CYV15G0203TB Dual HOTLink II Serializer

Name	I/O Characteristics	Signal Description
SPDSELA SPDSELB	3-Level Select ^[4] static control input	Serial Rate Select. The SPDSELx inputs specify the operating signaling-rate range of each channel's PLL. LOW = 195–400 MBd MID = 400–800 MBd HIGH = 800–1500 MBd.
Device Configuration and Control Bus Signals		
WREN	LVTTL input, asynchronous, internal pull-up	Control Write Enable. The WREN input writes the values of the DATA[3:0] bus into the latch specified by the address location on the ADDR[2:0] bus. ^[5]
ADDR[2:0]	LVTTL input asynchronous, internal pull-up	Control Addressing Bus. The ADDR[2:0] bus is the input address bus used to configure the device. The WREN input writes the values of the DATA[3:0] bus into the latch specified by the address location on the ADDR[2:0] bus. ^[5] <i>Table 2</i> lists the configuration latches within the device, and the initialization value of the latches upon the assertion of RESET. <i>Table 3</i> shows how the latches are mapped in the device.
DATA[3:0]	LVTTL input asynchronous, internal pull-up	Control Data Bus. The DATA[3:0] bus is the input data bus used to configure the device. The WREN input writes the values of the DATA[3:0] bus into the latch specified by address location on the ADDR[2:0] bus. ^[5] <i>Table 2</i> lists the configuration latches within the device, and the initialization value of the latches upon the assertion of RESET. <i>Table 3</i> shows how the latches are mapped in the device.
Internal Device Configuration Latches		
TXCKSEL[A..B]	Internal Latch ^[6]	Transmit Clock Select.
TXRATE[A..B]	Internal Latch ^[6]	Transmit PLL Clock Rate Select.
TXBIST[A..B]	Internal Latch ^[6]	Transmit Bist Disabled.
OE2[A..B]	Internal Latch ^[6]	Differential Serial Output Driver 2 Enable.
OE1[A..B]	Internal Latch ^[6]	Differential Serial Output Driver 1 Enable.
PABRST[A..B]	Internal Latch ^[6]	Transmit Clock Phase Alignment Buffer Reset.
Factory Test Modes		
SCANEN2	LVTTL input, internal pull-down	Factory Test 2. SCANEN2 input is for factory testing only. This input may be left as a NO CONNECT, or GND only.
TMEN3	LVTTL input, internal pull-down	Factory Test 3. TMEN3 input is for factory testing only. This input may be left as a NO CONNECT, or GND only.
Analog I/O		
OUTA1± OUTB1±	CML Differential Output	Primary Differential Serial Data Output. The OUTx1± PECL-compatible CML outputs (+3.3V referenced) are capable of driving terminated transmission lines or standard fiber-optic transmitter modules, and must be AC-coupled for PECL-compatible connections.
OUTA2± OUTB2±	CML Differential Output	Secondary Differential Serial Data Output. The OUTx2± PECL-compatible CML outputs (+3.3V referenced) are capable of driving terminated transmission lines or standard fiber-optic transmitter modules, and must be AC-coupled for PECL-compatible connections.

Notes:

- 3-Level Select inputs are used for static configuration. These are ternary inputs that make use of logic levels of LOW, MID, and HIGH. The LOW level is usually implemented by direct connection to V_{SS} (ground). The HIGH level is usually implemented by direct connection to V_{CC} (power). The MID level is usually implemented by not connecting the input (left floating), which allows it to self bias to the proper level.
- See *Device Configuration and Control Interface* for detailed information on the operation of the Configuration Interface.
- See *Device Configuration and Control Interface* for detailed information on the internal latches.

Pin Definitions (continued)

CYV15G0203TB Dual HOTLink II Serializer

Name	I/O Characteristics	Signal Description
JTAG Interface		
TMS	LVTTL Input, internal pull-up	Test Mode Select. Used to control access to the JTAG Test Modes. If maintained high for ≥ 5 TCLK cycles, the JTAG test controller is reset.
TCLK	LVTTL Input, internal pull-down	JTAG Test Clock.
TDO	3-State LVTTL Output	Test Data Out. JTAG data output buffer. High-Z while JTAG test mode is not selected.
TDI	LVTTL Input, internal pull-up	Test Data In. JTAG data input port.
TRST	LVTTL Input, internal pull-up	JTAG reset signal. When asserted (LOW), this input asynchronously resets the JTAG test access port controller.
Power		
V _{CC}		+3.3V Power.
GND		Signal and Power Ground for all internal circuits.

CYV15G0203TB HOTLink II Operation

The CYV15G0203TB is a highly configurable, independent clocking, dual-channel serializer, designed to support reliable transfer of large quantities of digital video data, using high-speed serial links from multiple sources to multiple destinations. This device supports two 10-bit channels.

CYV15G0203TB Transmit Data Path
Input Register

The parallel input bus TXDx[9:0] can be clocked in using TXCLKx (TXCKSELx = 0) or REFCLKx (TXCKSELx = 1).

Phase-Align Buffer

Data from each Input Register is passed to the associated Phase-Align Buffer, when the TXDx[9:0] input registers are clocked using TXCLKx (TXCKSELx = 0 and TXRATEx = 0). When the TXDx[9:0] input registers are clocked using REFCLKx± (TXCKSELx = 1) and REFCLKx± is a full-rate clock, the associated Phase Alignment Buffer in the transmit path is bypassed. These buffers are used to absorb clock phase differences between the TXCLKx input clock and the internal character clock for that channel.

Once initialized, TXCLKx is allowed to drift in phase as much as ± 180 degrees. If the input phase of TXCLKx drifts beyond the handling capacity of the Phase Align Buffer, TXERRx is asserted to indicate the loss of data, and remains asserted until the Phase Align Buffer is initialized. The phase of the TXCLKx relative to its associated internal character rate clock is initialized when the configuration latch PABRSTx is written as 0. When the associated TXERRx is deasserted, the Phase Align Buffer is initialized and input characters are correctly captured.

If the phase offset, between the initialized location of the input clock and REFCLKx, exceeds the skew handling capabilities of the Phase-Align Buffer, an error is reported on that channel's TXERRx output. This output indicates an error continuously until the Phase-Align Buffer for that channel is

reset. While the error remains active, the transmitter for that channel outputs a continuous "1001111000" character (LSB first) to indicate to the remote receiver that an error condition is present in the link.

Transmit BIST

Each channel contains an internal pattern generator that can be used to validate both the link and device operation. These generators are enabled by the associated TXBISTx latch via the device configuration interface. When enabled, a register in the associated channel becomes a signature pattern generator by logically converting to a Linear Feedback Shift Register (LFSR). This LFSR generates a 511-character sequence. This provides a predictable yet pseudo-random sequence that can be matched to an identical LFSR in the attached Receiver(s).

A device reset ($\overline{\text{RESET}}$ sampled LOW) presets the BIST Enable Latches to disable BIST on both channels.

All data present at the associated TXDx[9:0] inputs are ignored when BIST is active on that channel.

Transmit PLL Clock Multiplier

Each Transmit PLL Clock Multiplier accepts a character-rate or half-character-rate external clock at the associated REFCLKx± input, and that clock is multiplied by 10 or 20 (as selected by TXRATEx) to generate a bit-rate clock for use by the transmit shifter. It also provides a character-rate clock used by the transmit paths, and outputs this character rate clock as TXCLKOx.

Each clock multiplier PLL can accept a REFCLKx± input between 19.5 MHz and 150 MHz, however, this clock range is limited by the operating mode of the CYV15G0203TB clock multiplier (TXRATEx) and by the level on the associated SPDSELx input.

SPDSELx are 3-level select^[4] inputs that select one of three operating ranges for the serial data outputs and inputs of the associated channel. The serial signaling-rate and allowable range of REFCLKx± frequencies are listed in *Table 1*.

Table 1. Operating Speed Settings

SPDSELx	TXRATEx	REFCLKx± Frequency (MHz)	Signaling Rate (Mbps)
LOW	1	reserved	195–400
	0	19.5–40	
MID (Open)	1	20–40	400–800
	0	40–80	
HIGH	1	40–75	800–1500
	0	80–150	

The REFCLKx± inputs are differential inputs with each input internally biased to 1.4V. If the REFCLKx+ input is connected to a TTL, LVTTTL, or LVCMOS clock source, the input signal is recognized when it passes through the internally biased reference point. When driven by a single-ended TTL, LVTTTL, or LVCMOS clock source, connect the clock source to either the true or complement REFCLKx input, and leave the alternate REFCLKx input open (floating).

When both the REFCLKx+ and REFCLKx– inputs are connected, the clock source must be a differential clock. This can either be a differential LVPECL clock that is DC-or AC-coupled or a differential LVTTTL or LVCMOS clock.

By connecting the REFCLKx– input to an external voltage source, it is possible to adjust the reference point of the REFCLKx+ input for alternate logic levels. When doing so, it is necessary to ensure that the input differential crossing point remains within the parametric range supported by the input.

Serial Output Drivers

The serial output interface drivers use differential Current Mode Logic (CML) drivers to provide source-matched drivers for 50Ω transmission lines. These drivers accept data from the Transmit Shifter, which shifts the data out LSB first. These drivers have signal swings equivalent to that of standard PECL drivers, and are capable of driving AC-coupled optical modules or transmission lines.

Transmit Channels Enabled

Each driver can be enabled or disabled separately via the device configuration interface.

When a driver is disabled via the configuration interface, it is internally powered down to reduce device power. If both serial

drivers for a channel are in this disabled state, the associated internal logic for that channel is also powered down. A device reset (RESET sampled LOW) disables all output drivers.

Note. When a disabled channel (i.e., both outputs disabled) is re-enabled:

- data on the serial outputs may not meet all timing specifications for up to 250 μs
- the state of the phase-align buffer cannot be guaranteed, and a phase-align reset is required if the phase-align buffer is used

Device Configuration and Control Interface

The CYV15G0203TB is highly configurable via the configuration interface. The configuration interface allows each channel to be configured independently. *Table 2* lists the configuration latches within the device including the initialization value of the latches upon the assertion of RESET. *Table 3* shows how the latches are mapped in the device. Each row in the *Table 3* maps to a 4-bit latch bank. There are 6 such write-only latch banks. When WREN = 0, the logic value in the DATA[3:0] is latched to the latch bank specified by the values in ADDR[2:0]. The second column of *Table 3* specifies the channels associated with the corresponding latch bank. For example, the first three latch banks (0,1 and 2) consist of configuration bits for channel A.

Latch Types

There are two types of latch banks: static (S) and dynamic (D). Each channel is configured by 2 static and 1 dynamic latch banks. The S type contain those settings that normally do not change for a given application, whereas the D type controls the settings that could change during the application's lifetime. The first and second rows of each channel (address numbers 0, 1, 5, and 6) are the static control latches. The third row of latches for each channel (address numbers 2 and 7) are the dynamic control latches. Address numbers 3 and 4 are internal test registers.

Static Latch Values

There are some latches in the table that have a static value (i.e. 1, 0, or X). The latches that have a '1' or '0' must be configured with their corresponding value each time that their associated latch bank is configured. The latches that have an 'X' are don't cares and can be configured with any value.

Table 2. Device Configuration and Control Latch Descriptions

Name	Signal Description
TXCKSELA TXCKSELB	Transmit Clock Select. The initialization value of the TXCKSELx latch = 1. TXCKSELx selects the clock source used to write data into the Transmit Input Register. When TXCKSELx = 1, the associated input register TXDx[9:0] is clocked by REFCLKx↑. In this mode, the phase alignment buffer is bypassed. When TXCKSELx = 0, the associated TXCLKx↑ is used to clock in the input register TXDx[9:0].
TXRATEA TXRATEB	Transmit PLL Clock Rate Select. The initialization value of the TXRATEx latch = 0. TXRATEx is used to select the clock multiplier for the Transmit PLL. When TXRATEx = 0, each transmit PLL multiplies the associated REFCLKx± input by 10 to generate the serial bit-rate clock. When TXRATEx = 0, the TXCLKOx output clocks are full-rate clocks and follow the frequency and duty cycle of the associated REFCLKx± input. When TXRATEx = 1, each Transmit PLL multiplies the associated REFCLKx± input by 20 to generate the serial bit-rate clock. When TXRATEx = 1, the TXCLKOx output clocks are twice the frequency rate of the REFCLKx± input. When TXCLKSELx = 1 and TXRATEx = 1, the Transmit Data Inputs are captured using both the rising and falling edges of REFCLKx. TXRATEx = 1 and SPDSELx = LOW, is an invalid state and this combination is reserved.

Table 2. Device Configuration and Control Latch Descriptions (continued)

Name	Signal Description
TXBISTA TXBISTB	Transmit Bist Disabled. The initialization value of the TXBISTx latch = 1. TXBISTx selects if the transmit BIST is disabled or enabled. When TXBISTx = 1, the transmit BIST function is disabled. When TXBISTx = 0, the transmit BIST function is enabled.
OE2A OE2B	Secondary Differential Serial Data Output Driver Enable. The initialization value of the OE2x latch = 0. OE2x selects if the OUT2x± secondary differential output drivers are enabled or disabled. When OE2x = 1, the associated serial data output driver is enabled allowing data to be transmitted from the transmit shifter. When OE2x = 0, the associated serial data output driver is disabled. When a driver is disabled via the configuration interface, it is internally powered down to reduce device power. If both serial drivers for a channel are in this disabled state, the associated internal logic for that channel is also powered down. A device reset (RESET sampled LOW) disables all output drivers.
OE1A OE1B	Primary Differential Serial Data Output Driver Enable. The initialization value of the OE1x latch = 0. OE1x selects if the OUT1x± primary differential output drivers are enabled or disabled. When OE1x = 1, the associated serial data output driver is enabled allowing data to be transmitted from the transmit shifter. When OE1x = 0, the associated serial data output driver is disabled. When a driver is disabled via the configuration interface, it is internally powered down to reduce device power. If both serial drivers for a channel are in this disabled state, the associated internal logic for that channel is also powered down. A device reset (RESET sampled LOW) disables all output drivers.
PABRSTA PABRSTB	Transmit Clock Phase Alignment Buffer Reset. The initialization value of the PABRSTx latch = 1. The PABRSTx is used to re-center the Transmit Phase Align Buffer. When the configuration latch PABRSTx is written as a 0, the phase of the TXCLKx input clock relative to its associated REFCLKx± is initialized. PABRST is an asynchronous input, but is sampled by each TXCLKx↑ to synchronize it to the internal clock domain. PABRSTx is a self clearing latch. This eliminates the requirement of writing a 1 to complete the initialization of the Phase Alignment Buffer.

Device Configuration Strategy

The following is a series of ordered events needed to load the configuration latches on a per channel basis:

1. Pulse $\overline{\text{RESET}}$ Low after device power-up. This operation resets both channels.
2. Set the static latch banks for the target channel.
3. Set the dynamic bank of latches for the target channel.
Enable the output drivers. [Required step.]
4. Reset the Phase Alignment Buffer for the target channel.
[Optional if phase align buffer is bypassed.]

JTAG Support

The CYV15G0203TB contains a JTAG port to allow system level diagnosis of device interconnect. Of the available JTAG modes, boundary scan, and bypass are supported. This capability is present only on the LVTTL inputs and outputs and the REFCLKx± clock input. The high-speed serial inputs and outputs are not part of the JTAG test chain.

3-Level Select Inputs

Each 3-Level select inputs reports as two bits in the scan register. These bits report the LOW, MID, and HIGH state of the associated input as 00, 10, and 11 respectively

JTAG ID

The JTAG device ID for the CYV15G0203TB is '0C810069'x.

Table 3. Device Control Latch Configuration Table

ADDR	Channel	Type	DATA3	DATA2	DATA1	DATA0	Reset Value
0 (000b)	A	S	X	X	0	X	1111
1 (001b)	A	S	X	0	TXCKSELA	TXRATEA	0110
2 (010b)	A	D	TXBISTA	OE2A	OE1A	PABRSTA	1001
9 (101b)	B	S	X	X	0	X	1111
10 (110b)	B	S	X	0	TXCKSELB	TXRATEB	0110
11 (111b)	B	D	TXBISTB	OE2B	OE1B	PABRSTB	1001

Maximum Ratings

Above which the useful life may be impaired. User guidelines only, not tested

Storage Temperature	-65°C to +150°C
Ambient Temperature with Power Applied.....	-55°C to +125°C
Supply Voltage to Ground Potential	-0.5V to +3.8V
DC Voltage Applied to LVTTTL Outputs in High-Z State	-0.5V to $V_{CC} + 0.5V$
Output Current into LVTTTL Outputs (LOW).....	60 mA
DC Input Voltage.....	-0.5V to $V_{CC} + 0.5V$

Static Discharge Voltage..... > 2000 V
(per MIL-STD-883, Method 3015)

Latch-up Current..... > 200 mA

Power-up Requirements

The CYV15G0203TB requires one power-supply. The Voltage on any input or I/O pin cannot exceed the power pin during power-up.

Operating Range

Range	Ambient Temperature	V_{CC}
Commercial	0°C to +70°C	+3.3V ±5%

CYV15G0203TB DC Electrical Characteristics

Parameter	Description	Test Conditions	Min.	Max.	Unit
LVTTTL-compatible Outputs					
V_{OHT}	Output HIGH Voltage	$I_{OH} = -4 \text{ mA}$, $V_{CC} = \text{Min.}$	2.4		V
V_{OLT}	Output LOW Voltage	$I_{OL} = 4 \text{ mA}$, $V_{CC} = \text{Min.}$		0.4	V
I_{OST}	Output Short Circuit Current	$V_{OUT} = 0V^{[7]}$, $V_{CC} = 3.3V$	-20	-100	mA
I_{OZL}	High-Z Output Leakage Current	$V_{OUT} = 0V$, V_{CC}	-20	20	µA
LVTTTL-compatible Inputs					
V_{IHT}	Input HIGH Voltage		2.0	$V_{CC} + 0.3$	V
V_{ILT}	Input LOW Voltage		-0.5	0.8	V
I_{IHT}	Input HIGH Current	REFCLKx Input, $V_{IN} = V_{CC}$		1.5	mA
		Other Inputs, $V_{IN} = V_{CC}$		+40	µA
I_{ILT}	Input LOW Current	REFCLKx Input, $V_{IN} = 0.0V$		-1.5	mA
		Other Inputs, $V_{IN} = 0.0V$		-40	µA
I_{IHPDT}	Input HIGH Current with internal pull-down	$V_{IN} = V_{CC}$		+200	µA
I_{ILPUT}	Input LOW Current with internal pull-up	$V_{IN} = 0.0V$		-200	µA
LVDIFF Inputs: REFCLKx±					
$V_{DIFF}^{[8]}$	Input Differential Voltage		400	V_{CC}	mV
V_{IHHP}	Highest Input HIGH Voltage		1.2	V_{CC}	V
V_{ILLP}	Lowest Input LOW voltage		0.0	$V_{CC}/2$	V
$V_{COMREF}^{[9]}$	Common Mode Range		1.0	$V_{CC} - 1.2V$	V
3-Level Inputs					
V_{IHH}	Three-Level Input HIGH Voltage	$\text{Min.} \leq V_{CC} \leq \text{Max.}$	$0.87 * V_{CC}$	V_{CC}	V
V_{IMM}	Three-Level Input MID Voltage	$\text{Min.} \leq V_{CC} \leq \text{Max.}$	$0.47 * V_{CC}$	$0.53 * V_{CC}$	V
V_{ILL}	Three-Level Input LOW Voltage	$\text{Min.} \leq V_{CC} \leq \text{Max.}$	0.0	$0.13 * V_{CC}$	V
I_{IHH}	Input HIGH Current	$V_{IN} = V_{CC}$		200	µA
I_{IMM}	Input MID current	$V_{IN} = V_{CC}/2$	-50	50	µA
I_{ILL}	Input LOW current	$V_{IN} = \text{GND}$		-200	µA
Differential CML Serial Outputs: OUTA1±, OUTA2±, OUTB1±, OUTB2±, OUTC1±, OUTC2±, OUTD1±, OUTD2±					
V_{OHC}	Output HIGH Voltage (V_{CC} Referenced)	100Ω differential load	$V_{CC} - 0.5$	$V_{CC} - 0.2$	V
		150Ω differential load	$V_{CC} - 0.5$	$V_{CC} - 0.2$	V
V_{OLC}	Output LOW Voltage (V_{CC} Referenced)	100Ω differential load	$V_{CC} - 1.4$	$V_{CC} - 0.7$	V
		150Ω differential load	$V_{CC} - 1.4$	$V_{CC} - 0.7$	V

Notes:

- Tested one output at a time, output shorted for less than one second, less than 10% duty cycle.
- This is the minimum difference in voltage between the true and complement inputs required to ensure detection of a logic-1 or logic-0. A logic-1 exists when the true (+) input is more positive than the complement (-) input. A logic-0 exists when the complement (-) input is more positive than true (+) input.
- The common mode range defines the allowable range of REFCLKx+ and REFCLKx- when REFCLKx+ = REFCLKx-. This marks the zero-crossing between the true and complement inputs as the signal switches between a logic-1 and a logic-0.

CYV15G0203TB DC Electrical Characteristics (continued)

Parameter	Description	Test Conditions	Min.	Max.	Unit
V _{ODIF}	Output Differential Voltage (OUT+) - (OUT-)	100Ω differential load	450	900	mV
		150Ω differential load	560	1000	mV
Power Supply			Typ.	Max.	
I _{CC} ^[10,11]	Max Power Supply Current	REFCLKx = MAX Commercial	435	530	mA
I _{CC} ^[10,11]	Typical Power Supply Current	REFCLKx = 125 MHz Commercial	425	520	mA

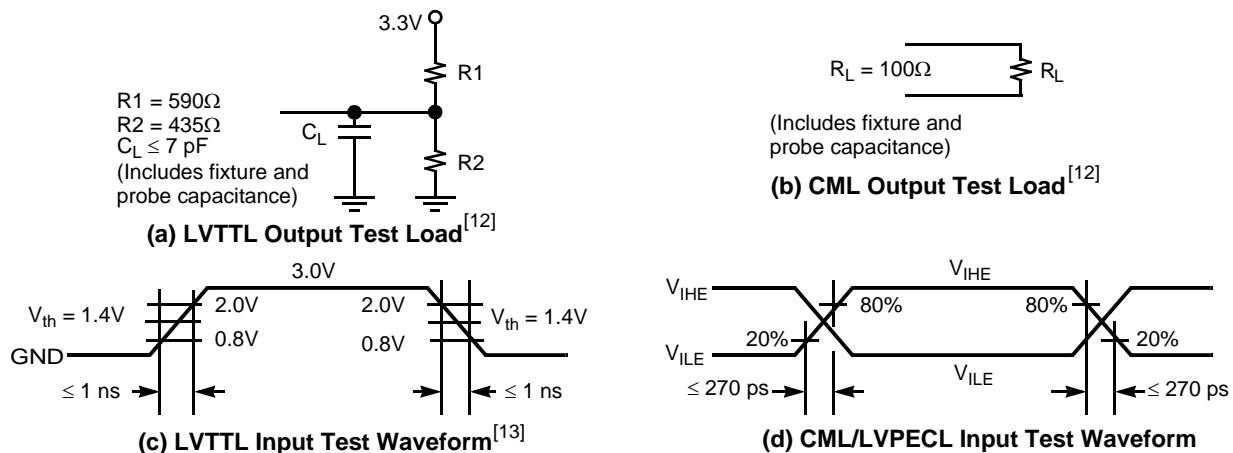
AC Test Loads and Waveforms

CYV15G0203TB AC Electrical Characteristics

Parameter	Description	Min.	Max.	Unit
CYV15G0203TB Transmitter LVTTTL Switching Characteristics Over the Operating Range				
f _{TS}	TXCLKx Clock Cycle Frequency	19.5	150	MHz
t _{TXCLK}	TXCLKx Period = 1/f _{TS}	6.66	51.28	ns
t _{TXCLKH} ^[14]	TXCLKx HIGH Time	2.2		ns
t _{TXCLKL} ^[14]	TXCLKx LOW Time	2.2		ns
t _{TXCLKR} ^[14, 15, 16, 17]	TXCLKx Rise Time	0.2	1.7	ns
t _{TXCLKF} ^[14, 15, 16, 17]	TXCLKx Fall Time	0.2	1.7	ns
t _{TXDS}	Transmit Data Set-up Time to TXCLKx↑ (TXCKSELx = 0)	2.2		ns
t _{TXDH}	Transmit Data Hold Time from TXCLKx↑ (TXCKSELx = 0)	1.0		ns
f _{TOS}	TXCLKOx Clock Frequency = 1x or 2x REFCLKx Frequency	19.5	150	MHz
t _{TXCLKO}	TXCLKOx Period = 1/f _{TOS}	6.66	51.28	ns
t _{TXCLKOD}	TXCLKO Duty Cycle centered at 60% HIGH time	-1.9	0	ns
CYV15G0203TB REFCLKx Switching Characteristics Over the Operating Range				
f _{REF}	REFCLKx Clock Frequency	19.5	150	MHz
t _{REFCLK}	REFCLKx Period = 1/f _{REF}	6.6	51.28	ns

Notes:

- Maximum I_{CC} is measured with V_{CC} = MAX, T_A = 25°C, with both channels and Serial Line Drivers enabled, sending a continuous alternating 01 pattern, and outputs unloaded.
- Typical I_{CC} is measured under similar conditions except with V_{CC} = 3.3V, T_A = 25°C, with both channels enabled and one Serial Line Driver per channel sending a continuous alternating 01 pattern. The redundant outputs on each channel are powered down.
- Cypress uses constant current (ATE) load configurations and forcing functions. This figure is for reference only.
- The LVTTTL switching threshold is 1.4V. All timing references are made relative to where the signal edges cross the threshold voltage.
- Tested initially and after any design or process changes that may affect these parameters, but not 100% tested.
- The ratio of rise time to falling time must not vary by greater than 2:1.
- For a given operating frequency, neither rise or fall specification can be greater than 20% of the clock-cycle period or the data sheet maximum time.
- All transmit AC timing parameters measured with 1 ns typical rise time and fall time.

CYV15G0203TB AC Electrical Characteristics (continued)

Parameter	Description	Min.	Max.	Unit	
t _{REFH}	REFCLKx HIGH Time (TXRATEx = 1)(Half Rate)	5.9		ns	
	REFCLKx HIGH Time (TXRATEx = 0)(Full Rate)	2.9 ^[14]		ns	
t _{REFL}	REFCLKx LOW Time (TXRATEx = 1)(Half Rate)	5.9		ns	
	REFCLKx LOW Time (TXRATEx = 0)(Full Rate)	2.9 ^[14]		ns	
t _{REFD} ^[18]	REFCLKx Duty Cycle	30	70	%	
t _{REFR} ^[14, 15, 16, 17]	REFCLKx Rise Time (20%–80%)		2	ns	
t _{REFF} ^[14, 15, 16, 17]	REFCLKx Fall Time (20%–80%)		2	ns	
t _{TREFDS}	Transmit Data Set-up Time to REFCLKx - Full Rate (TXRATEx = 0, TXCKSELx = 1)	2.4		ns	
	Transmit Data Set-up Time to REFCLKx - Half Rate (TXRATEx = 1, TXCKSELx = 1)	2.3		ns	
t _{TREFDH}	Transmit Data Hold Time from REFCLKx - Full Rate (TXRATEx = 0, TXCKSELx = 1)	1.0		ns	
	Transmit Data Hold Time from REFCLKx - Half Rate (TXRATEx = 1, TXCKSELx = 1)	1.6		ns	
CYV15G0203TB Bus Configuration Write Timing Characteristics Over the Operating Range					
t _{DATAH}	Bus Configuration Data Hold	0		ns	
t _{DATAS}	Bus Configuration Data Setup	10		ns	
t _{WRENp}	Bus Configuration WREN Pulse Width	10		ns	
CYV15G0203TB JTAG Test Clock Characteristics Over the Operating Range					
f _{TCLK}	JTAG Test Clock Frequency		20	MHz	
t _{TCLK}	JTAG Test Clock Period	50		ns	
CYV15G0203TB Device RESET Characteristics Over the Operating Range					
t _{RST}	Device RESET Pulse Width	30		ns	
CYV15G0203TB Transmit Serial Outputs and TX PLL Characteristics Over the Operating Range					
Parameter	Description	Condition	Min.	Max.	Unit
t _B	Bit Time		5128	660	ps
t _{RISE} ^[14]	CML Output Rise Time 20–80% (CML Test Load)	SPDSELx = HIGH	50	270	ps
		SPDSELx = MID	100	500	ps
		SPDSELx =LOW	180	1000	ps
t _{FALL} ^[14]	CML Output Fall Time 80–20% (CML Test Load)	SPDSELx = HIGH	50	270	ps
		SPDSELx = MID	100	500	ps
		SPDSELx =LOW	180	1000	ps

PLL Characteristics

Parameter	Description	Condition	Min.	Typ.	Max.	Unit
CYV15G0203TB Transmitter PLL Characteristics						
t _{JTGENSD} ^[14, 19]	Transmit Jitter Generation - SD Data Rate	REFCLKx = 27 MHz		200		ps
t _{JTGENHD} ^[14, 19]	Transmit Jitter Generation - HD Data Rate	REFCLKx = 148.5 MHz		76		ps
t _{TXLOCK}	Transmit PLL lock to REFCLKx±				200	µs

Notes:

18. The duty cycle specification is a simultaneous condition with the t_{REFH} and t_{REFL} parameters. This means that at faster character rates the REFCLKx± duty cycle cannot be as large as 30%–70%.

19. While sending BIST data at the corresponding data rate, after 10,000 histogram hits on a digital sampling oscilloscope, time referenced to REFCLKx± input.

Capacitance^[14]

Parameter	Description	Test Conditions	Max.	Unit
C _{INTTL}	TTL Input Capacitance	T _A = 25°C, f ₀ = 1 MHz, V _{CC} = 3.3V	7	pF
C _{INPECL}	PECL input Capacitance	T _A = 25°C, f ₀ = 1 MHz, V _{CC} = 3.3V	4	pF

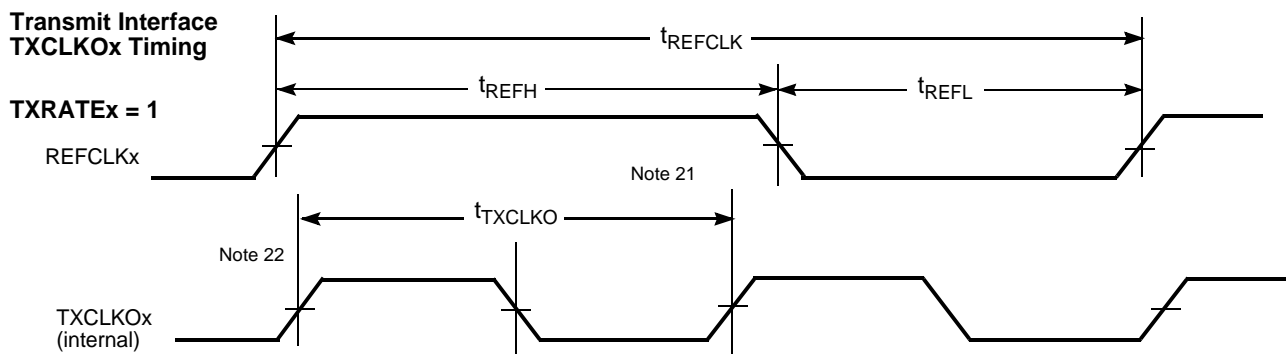
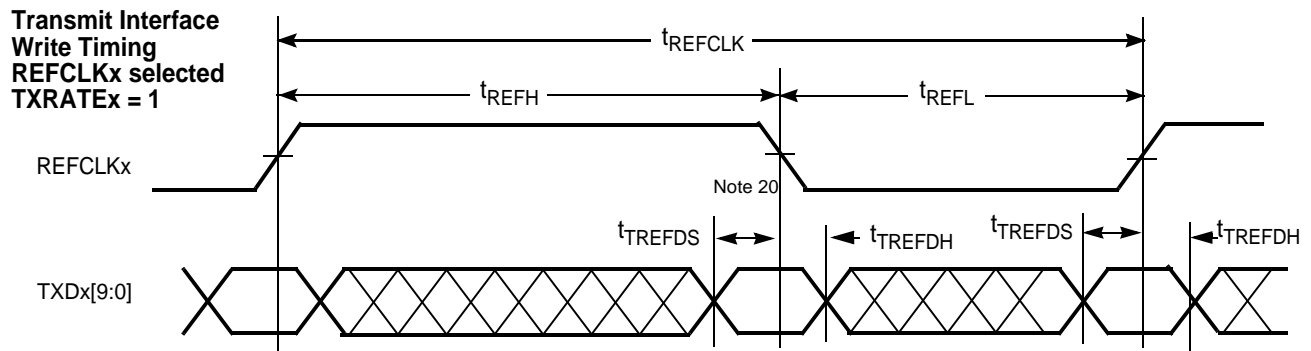
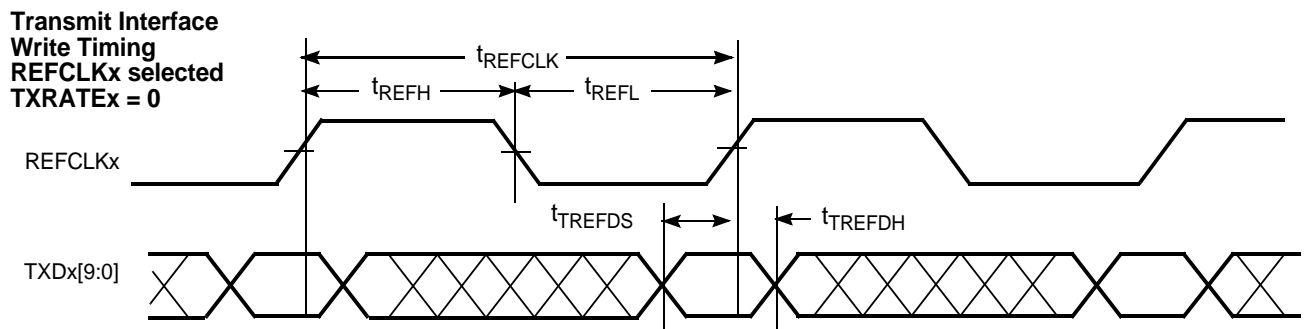
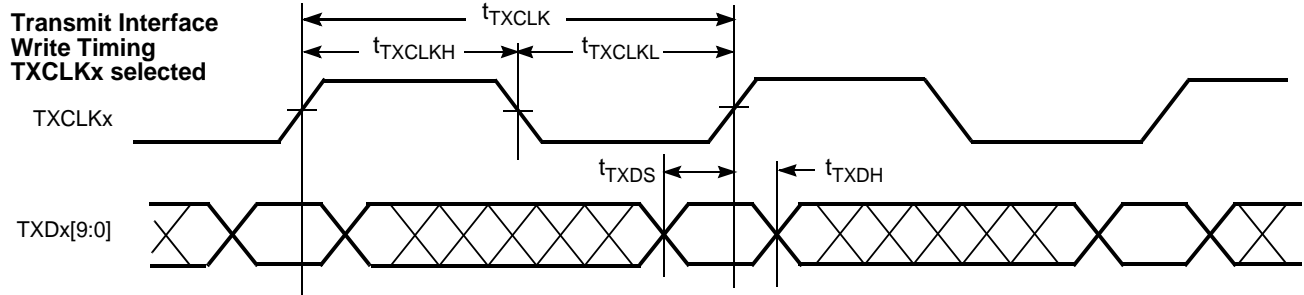
CYV15G0203TB HOTLink II Transmitter Switching Waveforms

Notes:

- 20. When REFCLKx± is configured for half-rate operation (TXRATEx = 1) and data is captured using REFCLKx instead of a TXCLKx clock. Data is captured using both the rising and falling edges of REFCLKx.
- 21. The TXCLKOx output remains at the character rate regardless of the state of TXRATEx and does not follow the duty cycle of REFCLKx±.
- 22. The rising edge of TXCLKOx output has no direct phase relationship to the REFCLKx± input.

CYV15G0203TB HOTLink II Transmitter Switching Waveforms (continued)

CYV15G0203TB HOTLink II Bus Configuration Switching Waveforms
Bus Configuration Write Timing

Table 4. Package Coordinate Signal Allocation

Ball ID	Signal Name	Signal Type	Ball ID	Signal Name	Signal Type	Ball ID	Signal Name	Signal Type
A01	NC	NO CONNECT	C07	NC	NO CONNECT	F17	NC	NO CONNECT
A02	NC	NO CONNECT	C08	GND	GROUND	F18	NC	NO CONNECT
A03	NC	NO CONNECT	C09	NC	NO CONNECT	F19	NC	NO CONNECT
A04	NC	NO CONNECT	C10	NC	NO CONNECT	F20	NC	NO CONNECT
A05	VCC	POWER	C11	DATA[2]	LVTTTL IN PU	G01	GND	GROUND
A06	NC	NO CONNECT	C12	DATA[0]	LVTTTL IN PU	G02	WREN	LVTTTL IN PU
A07	OUTB1-	CML OUT	C13	GND	GROUND	G03	GND	GROUND
A08	GND	GROUND	C14	NC	NO CONNECT	G04	GND	GROUND
A09	GND	GROUND	C15	SPDSELB	3-LEVEL SEL	G17	NC	NO CONNECT
A10	OUTB2-	CML OUT	C16	VCC	POWER	G18	NC	NO CONNECT
A11	GND	GROUND	C17	NC	NO CONNECT	G19	SPDSELA	3-LEVEL SEL
A12	OUTA1-	CML OUT	C18	TRST	LVTTTL IN PU	G20	NC	NO CONNECT
A13	GND	GROUND	C19	GND	GROUND	H01	GND	GROUND
A14	GND	GROUND	C20	TDO	LVTTTL 3-S OUT	H02	GND	GROUND
A15	OUTA2-	CML OUT	D01	TCLK	LVTTTL IN PD	H03	GND	GROUND
A16	VCC	POWER	D02	RESET	LVTTTL IN PU	H04	GND	GROUND
A17	VCC	POWER	D03	VCC	POWER	H17	GND	GROUND
A18	NC	NO CONNECT	D04	VCC	POWER	H18	GND	GROUND
A19	VCC	POWER	D05	VCC	POWER	H19	GND	GROUND
A20	NC	NO CONNECT	D06	VCC	POWER	H20	GND	GROUND
B01	VCC	POWER	D07	NC	NO CONNECT	J01	GND	GROUND
B02	NC	NO CONNECT	D08	GND	GROUND	J02	GND	GROUND
B03	VCC	POWER	D09	GND	GROUND	J03	GND	GROUND
B04	NC	NO CONNECT	D10	DATA[3]	LVTTTL IN PU	J04	GND	GROUND
B05	VCC	POWER	D11	DATA[1]	LVTTTL IN PU	J17	NC	NO CONNECT
B06	VCC	POWER	D12	GND	GROUND	J18	NC	NO CONNECT
B07	OUTB1+	CML OUT	D13	GND	GROUND	J19	NC	NO CONNECT
B08	GND	GROUND	D14	GND	GROUND	J20	NC	NO CONNECT
B09	NC	NO CONNECT	D15	NC	NO CONNECT	K01	NC	NO CONNECT
B10	OUTB2+	CML OUT	D16	VCC	POWER	K02	NC	NO CONNECT
B11	NC	NO CONNECT	D17	NC	NO CONNECT	K03	GND	GROUND
B12	OUTA1+	CML OUT	D18	NC	NO CONNECT	K04	GND	GROUND
B13	GND	GROUND	D19	SCANEN2	LVTTTL IN PD	K17	NC	NO CONNECT
B14	NC	NO CONNECT	D20	TMEN3	LVTTTL IN PD	K18	NC	NO CONNECT
B15	OUTA2+	CML OUT	E01	VCC	POWER	K19	NC	NO CONNECT
B16	VCC	POWER	E02	VCC	POWER	K20	NC	NO CONNECT
B17	NC	NO CONNECT	E03	VCC	POWER	L01	NC	NO CONNECT
B18	NC	NO CONNECT	E04	VCC	POWER	L02	NC	NO CONNECT
B19	NC	NO CONNECT	E17	VCC	POWER	L03	NC	NO CONNECT
B20	NC	NO CONNECT	E18	VCC	POWER	L04	GND	GROUND
C01	TDI	LVTTTL IN PU	E19	VCC	POWER	L17	NC	NO CONNECT
C02	TMS	LVTTTL IN PU	E20	VCC	POWER	L18	NC	NO CONNECT
C03	VCC	POWER	F01	NC	NO CONNECT	L19	NC	NO CONNECT

Table 4. Package Coordinate Signal Allocation (continued)

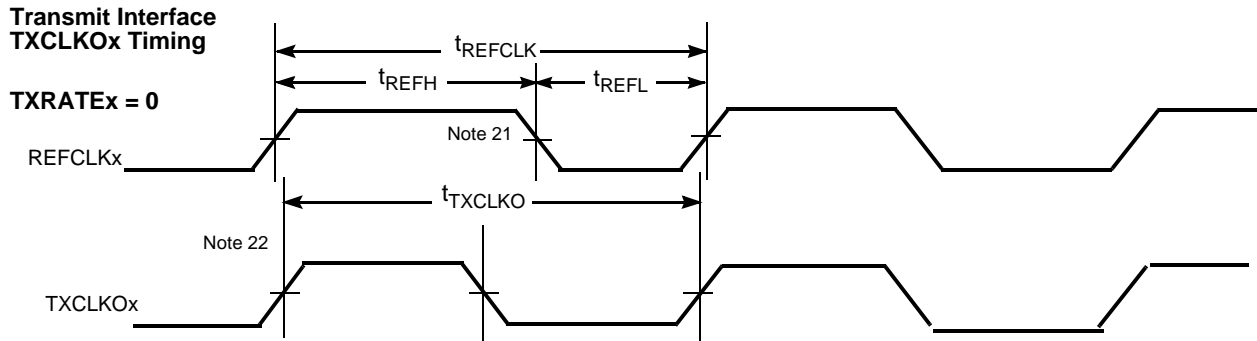
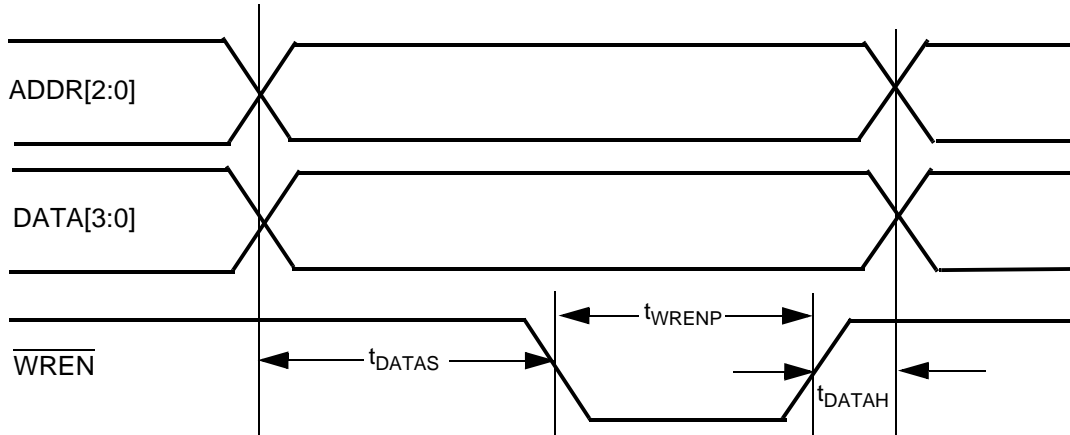
Ball ID	Signal Name	Signal Type	Ball ID	Signal Name	Signal Type	Ball ID	Signal Name	Signal Type
C04	VCC	POWER	F02	NC	NO CONNECT	L20	GND	GROUND
C05	VCC	POWER	F03	VCC	POWER	M01	NC	NO CONNECT
C06	NC	NO CONNECT	F04	NC	NO CONNECT	M02	NC	NO CONNECT
M03	NC	NO CONNECT	U03	TXDB[2]	LVTTTL IN	W03	NC	NO CONNECT
M04	NC	NO CONNECT	U04	TXDB[9]	LVTTTL IN	W04	NC	NO CONNECT
M17	NC	NO CONNECT	U05	VCC	POWER	W05	VCC	POWER
M18	NC	NO CONNECT	U06	NC	NO CONNECT	W06	NC	NO CONNECT
M19	NC	NO CONNECT	U07	NC	NO CONNECT	W07	NC	NO CONNECT
M20	GND	GROUND	U08	GND	GROUND	W08	GND	GROUND
N01	GND	GROUND	U09	TXDA[9]	LVTTTL IN	W09	ADDR [2]	LVTTTL IN PU
N02	GND	GROUND	U10	ADDR [0]	LVTTTL IN PU	W10	ADDR [1]	LVTTTL IN PU
N03	GND	GROUND	U11	REFCLKB-	PECL IN	W11	NC	NO CONNECT
N04	GND	GROUND	U12	TXDA[1]	LVTTTL IN	W12	TXERRA	LVTTTL OUT
N17	GND	GROUND	U13	GND	GROUND	W13	GND	GROUND
N18	GND	GROUND	U14	TXDA[4]	LVTTTL IN	W14	TXDA[2]	LVTTTL IN
N19	GND	GROUND	U15	TXDA[8]	LVTTTL IN	W15	TXDA[6]	LVTTTL IN
N20	GND	GROUND	U16	VCC	POWER	W16	VCC	POWER
P01	NC	NO CONNECT	U17	NC	NO CONNECT	W17	NC	NO CONNECT
P02	NC	NO CONNECT	U18	VCC	POWER	W18	REFCLKA+	PECL IN
P03	NC	NO CONNECT	U19	NC	NO CONNECT	W19	NC	NO CONNECT
P04	NC	NO CONNECT	U20	NC	NO CONNECT	W20	NC	NO CONNECT
P17	GND	GROUND	V01	TXDB[3]	LVTTTL IN	Y01	TXDB[6]	LVTTTL IN
P18	GND	GROUND	V02	TXDB[4]	LVTTTL IN	Y02	TXCLKB	LVTTTL IN PD
P19	GND	GROUND	V03	TXDB[8]	LVTTTL IN	Y03	NC	NO CONNECT
P20	GND	GROUND	V04	NC	NO CONNECT	Y04	NC	NO CONNECT
R01	NC	NO CONNECT	V05	VCC	POWER	Y05	VCC	POWER
R02	NC	NO CONNECT	V06	NC	NO CONNECT	Y06	NC	NO CONNECT
R03	NC	NO CONNECT	V07	NC	NO CONNECT	Y07	NC	NO CONNECT
R04	NC	NO CONNECT	V08	GND	GROUND	Y08	GND	GROUND
R17	VCC	POWER	V09	NC	NO CONNECT	Y09	TXCLKOB	LVTTTL OUT
R18	VCC	POWER	V10	GND	GROUND	Y10	NC	NO CONNECT
R19	VCC	POWER	V11	REFCLKB+	PECL IN	Y11	TXCLKA	LVTTTL IN PD
R20	VCC	POWER	V12	TXCLKOA	LVTTTL OUT	Y12	NC	NO CONNECT
T01	VCC	POWER	V13	GND	GROUND	Y13	GND	GROUND
T02	VCC	POWER	V14	TXDA[3]	LVTTTL IN	Y14	TXDA[0]	LVTTTL IN
T03	VCC	POWER	V15	TXDA[7]	LVTTTL IN	Y15	TXDA[5]	LVTTTL IN
T04	VCC	POWER	V16	VCC	POWER	Y16	VCC	POWER
T17	VCC	POWER	V17	NC	NO CONNECT	Y17	TXERRB	LVTTTL OUT
T18	VCC	POWER	V18	NC	NO CONNECT	Y18	REFCLKA-	PECL IN
T19	VCC	POWER	V19	NC	NO CONNECT	Y19	NC	NO CONNECT
T20	VCC	POWER	V20	NC	NO CONNECT	Y20	NC	NO CONNECT
U01	TXDB[0]	LVTTTL IN	W01	TXDB[5]	LVTTTL IN			
U02	TXDB[1]	LVTTTL IN	W02	TXDB[7]	LVTTTL IN			

Ordering Information

Speed	Ordering Code	Package Name	Package Type	Operating Range
Standard	CYV15G0203TB-BGC	BL256	256-Ball Thermally Enhanced Ball Grid Array	Commercial
Standard	CYV15G0203TB-BGXC	BL256	Pb-Free 256-Ball Thermally Enhanced Ball Grid Array	Commercial

Package Diagram

256-Lead L2 Ball Grid Array (27 x 27 x 1.57 mm) BL256

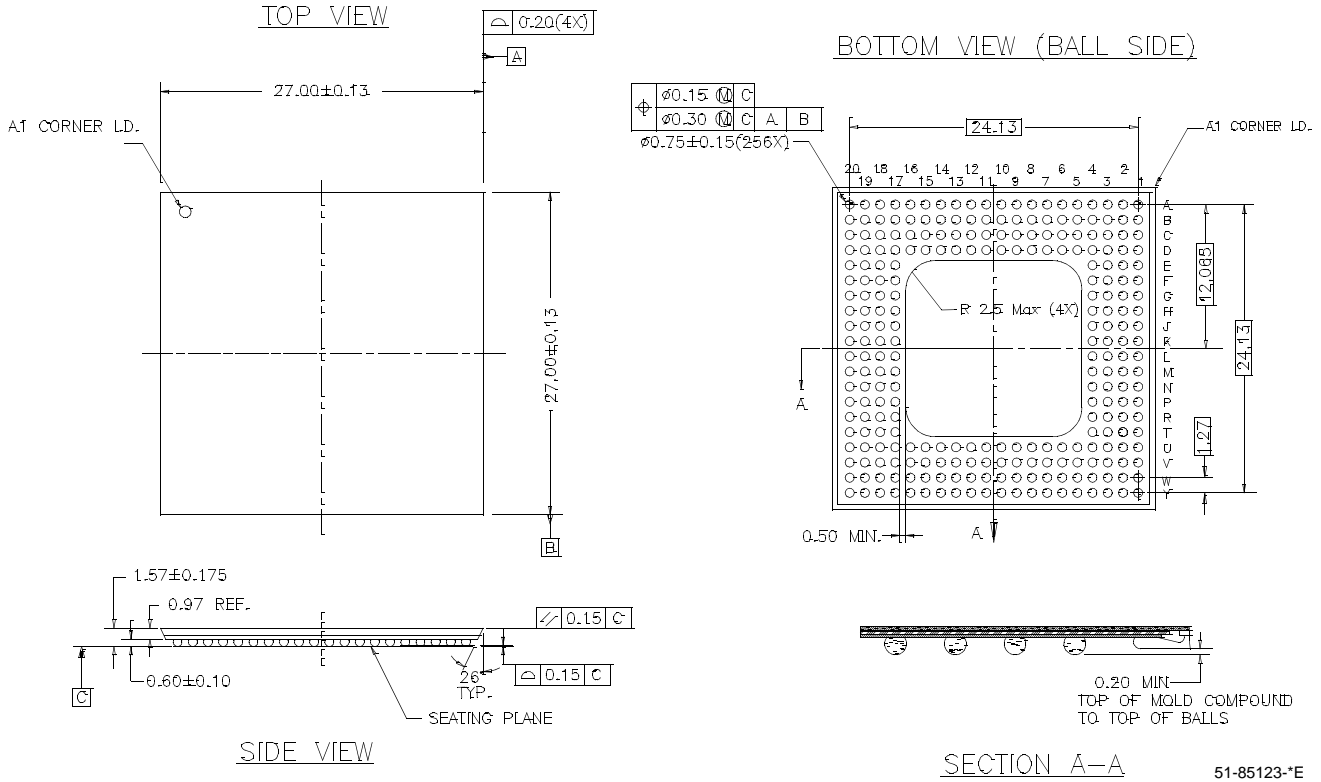

HOTLink is a registered trademark and HOTLink II is a trademark of Cypress Semiconductor. All product and company names mentioned in this document may be the trademarks of their respective holders.

Document History Page

Document Title: CYV15G0203TB Independent Clock Dual HOTLink II™ Serializer Document Number: 38-02105				
REV.	ECN NO.	ISSUE DATE	ORIG. OF CHANGE	DESCRIPTION OF CHANGE
**	246850	See ECN	FRE	New Data Sheet
*A	338721	See ECN	SUA	Added Pb-Free package option availability
*B	384307	See ECN	AGT	Revised setup and hold times (t_{TXDH} , t_{TREFDS} , t_{TREFDH})

Looking for pricing, stock, or lifecycle information?

Click below to explore more details on WIN SOURCE:

 [View CYV15G0203TB-BGC on WIN SOURCE](#)

 [Infineon Technologies](#) Information

Optimize Your Supply Chain with WIN SOURCE Solutions

-  Global Sourcing Solution
-  Obsolete Management
-  Cost Control Management
-  Shortage Management
-  Alternative Solution
-  Excess Inventory Management