



**THE DATASHEET OF
CY62148DV30LL-70ZSXA**



4-Mbit (512K x 8) MoBL[®] Static RAM

Features

- Temperature Ranges
 - Industrial: -40°C to 85°C
 - Automotive-A: -40°C to 85°C
- Very high speed: 55 ns
 - Wide voltage range: 2.20V – 3.60V
- Pin-compatible with CY62148CV25, CY62148CV30 and CY62148CV33
- Ultra low active power
 - Typical active current: 1.5 mA @ f = 1 MHz
 - Typical active current: 8 mA @ f = f_{max}(55-ns speed)
- Ultra low standby power
- Easy memory expansion with \overline{CE} , and \overline{OE} features
- Automatic power-down when deselected
- CMOS for optimum speed/power
- Available in Pb-free and non Pb-free 36-ball VFBGA, Pb-free 32-pin TSOPII and 32-pin SOIC packages

Functional Description^[1]

The CY62148DV30 is a high-performance CMOS static RAM organized as 512K words by 8 bits. This device features advanced circuit design to provide ultra-low active current. This is ideal for providing More Battery Life™ (MoBL[®]) in portable applications such as cellular telephones. The device also has an automatic power-down feature that significantly reduces power consumption. The device can be put into standby mode reducing power consumption when deselected (\overline{CE} HIGH). The eight input and output pins (IO₀ through IO₇) are placed in a high-impedance state when:

- Deselected (\overline{CE} HIGH)
- Outputs are disabled (\overline{OE} HIGH)
- When the write operation is active (\overline{CE} LOW and \overline{WE} LOW)

Write to the device by taking Chip Enable (\overline{CE}) and Write Enable (\overline{WE}) inputs LOW. Data on the eight IO pins (IO₀ through IO₇) is then written into the location specified on the address pins (A₀ through A₁₈).

Read from the device by taking Chip Enable (\overline{CE}) and Output Enable (\overline{OE}) LOW while forcing Write Enable (\overline{WE}) HIGH. Under these conditions, the contents of the memory location specified by the address pins will appear on the IO pins.

Logic Block Diagram

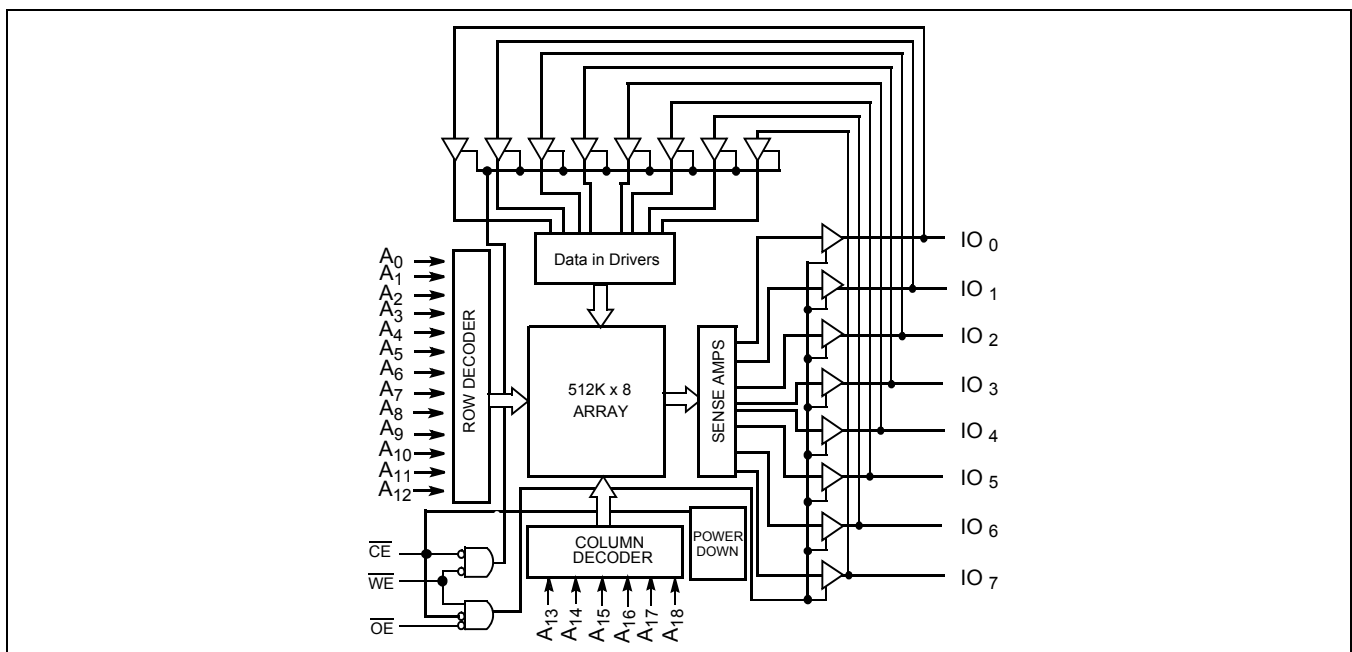

Note:

1. For best practice recommendations, refer to the Cypress application note "System Design Guidelines" on <http://www.cypress.com>.

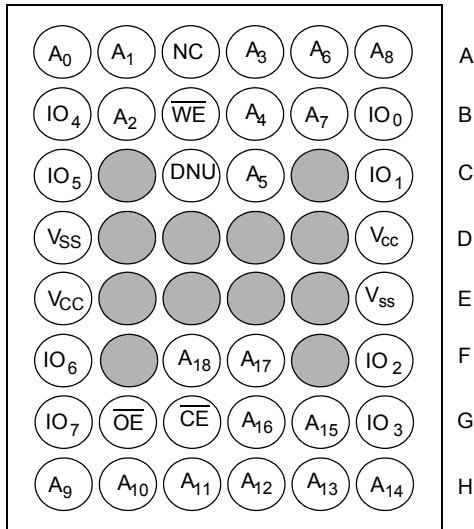
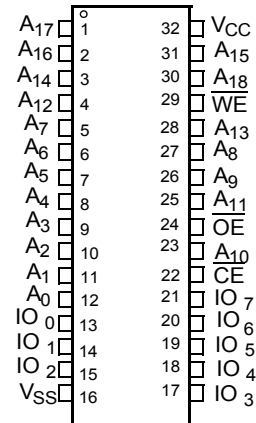
Pin Configuration^[2, 3]
36-ball VFBGA Pinout
Top View

32-pin SOIC / TSOP II Pinout
Top View

Product Portfolio

Product	Range	V _{CC} Range (V)			Speed (ns)	Power Dissipation					
						Operating I _{CC} (mA)				Standby I _{SB2} (μA)	
		Min	Typ ^[4]	Max		f = 1 MHz		f = f _{max}			
						Typ ^[4]	Max	Typ ^[4]	Max	Typ ^[4]	Max
CY62148DV30L	Industrial	2.2	3.0	3.6	55	1.5	3	8	15	2	12
CY62148DV30LL	Industrial				55	1.5	3	8	10	2	8
CY62148DV30LL	Industrial				70	1.5	3	8	10	2	8
CY62148DV30LL	Automotive-A				70	1.5	3	8	10	2	8

Notes:

- NC pins are not connected on the die.
- DNU pins have to be left floating or tied to V_{SS} to ensure proper application.
- Typical values are included for reference only and are not guaranteed or tested. Typical values are measured at V_{CC} = V_{CC(typ)}, T_A = 25°C.

Maximum Ratings

(Exceeding maximum ratings may impair the useful life of the device. For user guidelines, not tested.)

Storage Temperature	-65°C to +150°C
Ambient Temperature with Power Applied	55°C to +125°C
Supply Voltage to Ground Potential	-0.3V to $V_{CC(max)} + 0.3V$
DC Voltage Applied to Outputs in High-Z State ^[5, 6]	-0.3V to $V_{CC(max)} + 0.3V$
DC Input Voltage ^[5, 6]	-0.3V to $V_{CC(max)} + 0.3V$

Output Current into Outputs (LOW)	20 mA
Static Discharge Voltage	> 2001V (per MIL-STD-883, Method 3015)
Latch-up Current	> 200 mA

Operating Range

Product	Range	Ambient Temperature	$V_{CC}^{[7]}$
CY62148DV30L	Industrial	-40°C to +85°C	2.2V to 3.6V
CY62148DV30LL			
CY62148DV30LL	Automotive-A	-40°C to +85°C	

Electrical Characteristics Over the Operating Range

Parameter	Description	Test Conditions		55 ns			70 ns			Unit	
				Min	Typ ^[4]	Max	Min	Typ ^[4]	Max		
V_{OH}	Output HIGH Voltage	$I_{OH} = -0.1 \text{ mA}$	$V_{CC} = 2.20V$	2.0			2.0			V	
		$I_{OH} = -1.0 \text{ mA}$	$V_{CC} = 2.70V$	2.4			2.4			V	
V_{OL}	Output LOW Voltage	$I_{OL} = 0.1 \text{ mA}$	$V_{CC} = 2.20V$			0.4			0.4	V	
		$I_{OL} = 2.1 \text{ mA}$	$V_{CC} = 2.70V$			0.4			0.4	V	
V_{IH}	Input HIGH Voltage	$V_{CC} = 2.2V \text{ to } 2.7V$		1.8		$V_{CC} + 0.3V$	1.8		$V_{CC} + 0.3V$	V	
		$V_{CC} = 2.7V \text{ to } 3.6V$		2.2		$V_{CC} + 0.3V$	2.2		$V_{CC} + 0.3V$	V	
V_{IL}	Input LOW Voltage	$V_{CC} = 2.2V \text{ to } 2.7V$		-0.3		0.6	-0.3		0.6	V	
		$V_{CC} = 2.7V \text{ to } 3.6V$		-0.3		0.8	-0.3		0.8	V	
I_{IX}	Input Leakage Current	$GND \leq V_I \leq V_{CC}$		-1		+1	-1		+1	μA	
I_{OZ}	Output Leakage Current	$GND \leq V_O \leq V_{CC}$, Output Disabled		-1		+1	-1		+1	μA	
I_{CC}	V_{CC} Operating Supply Current	$f = f_{max} = 1/t_{RC}$	$V_{CC} = V_{CC(max)}$ $I_{OUT} = 0 \text{ mA}$ CMOS levels	Ind'l	L	8	15				mA
				Ind'l	LL	8	10		8	10	mA
				Auto-A	LL				8	10	mA
		$f = 1 \text{ MHz}$		Ind'l	L	1.5	3				mA
				Ind'l	LL	1.5	3		1.5	3	mA
				Auto-A	LL				1.5	3	mA
I_{SB1}	Automatic CE Power-down Current — CMOS Inputs	$\overline{CE} \geq V_{CC} - 0.2V$, $V_{IN} \geq V_{CC} - 0.2V$, $V_{IN} \leq 0.2V$ $f = f_{max}$ (Address and Data Only), $f = 0$ (\overline{OE} , and \overline{WE}), $V_{CC} = 3.60V$		Ind'l	L	2	12				μA
				Ind'l	LL	2	8		2	8	
				Auto-A	LL				2	8	
I_{SB2}	Automatic CE Power-down Current — CMOS Inputs	$\overline{CE} \geq V_{CC} - 0.2V$, $V_{IN} \geq V_{CC} - 0.2V$ or $V_{IN} \leq 0.2V$, $f = 0$, $V_{CC} = 3.60V$		Ind'l	L	2	12				μA
				Ind'l	LL	2	8		2	8	
				Auto-A	LL				2	8	

Notes:

5. $V_{IL(min)}$ = -2.0V for pulse durations less than 20 ns.
6. $V_{IH(max)}$ = $V_{CC} + 0.75V$ for pulse durations less than 20 ns.
7. Full device AC operation assumes a 100 μs ramp time from 0 to $V_{CC(min)}$ and 200 μs wait time after V_{CC} stabilization.

Capacitance (for all packages)^[8]

Parameter	Description	Test Conditions	Max	Unit
C _{IN}	Input Capacitance	T _A = 25°C, f = 1 MHz, V _{CC} = V _{CC(typ)}	10	pF
C _{OUT}	Output Capacitance		10	pF

Thermal Resistance

Parameter	Description	Test Conditions	VFBGA	TSOP II	SOIC	Unit
θ _{JA}	Thermal Resistance (Junction to Ambient)	Still Air, soldered on a 3 x 4.5 inch, four-layer printed circuit board	72	75.13	55	°C/W
θ _{JC}	Thermal Resistance (Junction to Case)		8.86	8.95	22	°C/W

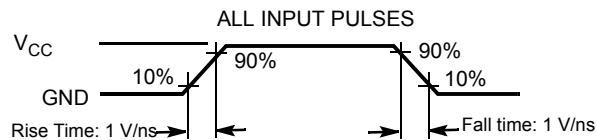
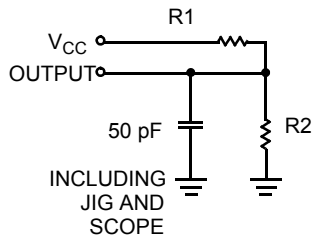
AC Test Loads and Waveforms

Equivalent to: THÉVENIN EQUIVALENT

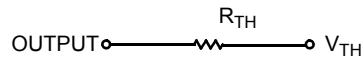

Parameters	2.5V (2.2V – 2.7V)	3.0V (2.7V – 3.6V)	Unit
R1	16667	1103	Ω
R2	15385	1554	Ω
R _{TH}	8000	645	Ω
V _{TH}	1.20	1.75	V

Data Retention Characteristics (Over the Operating Range)

Parameter	Description	Conditions	Min	Typ ^[4]	Max	Unit
V _{DR}	V _{CC} for Data Retention		1.5			V
I _{CCDR}	Data Retention Current	V _{CC} = 1.5V, $\overline{CE} \geq V_{CC} - 0.2V$, V _{IN} ≥ V _{CC} - 0.2V or V _{IN} ≤ 0.2V			9	μA
					Ind'I/Auto-A	LL
t _{CDR} ^[8]	Chip Deselect to Data Retention Time		0			ns
t _R ^[9]	Operation Recovery Time		t _{RC}			ns

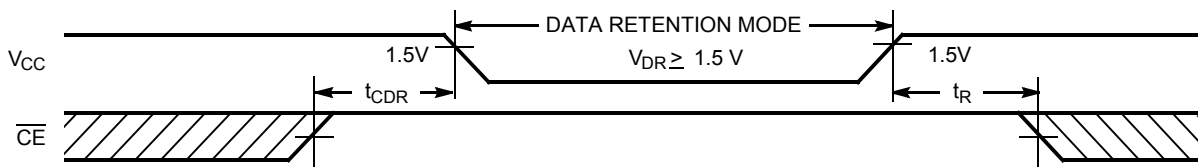
Data Retention Waveform

Notes:

8. Tested initially and after any design or process changes that may affect these parameters.
9. Full Device AC operation requires linear V_{CC} ramp from V_{DR} to V_{CC(min)} ≥ 100 μs or stable at V_{CC(min)} ≥ 100 μs.

Switching Characteristics (Over the Operating Range)^[10]

Parameter	Description	55 ns		70 ns		Unit
		Min	Max	Min	Max	
Read Cycle						
t _{RC}	Read Cycle Time	55		70		ns
t _{AA}	Address to Data Valid		55		70	ns
t _{OHA}	Data Hold from Address Change	10		10		ns
t _{ACE}	\overline{CE} LOW to Data Valid		55		70	ns
t _{DOE}	\overline{OE} LOW to Data Valid		25		35	ns
t _{LZOE}	\overline{OE} LOW to Low Z ^[11]	5		5		ns
t _{HZOE}	\overline{OE} HIGH to High Z ^[11,12]		20		25	ns
t _{LZCE}	\overline{CE} LOW to Low Z ^[11]	10		10		ns
t _{HZCE}	\overline{CE} HIGH to High Z ^[11, 12]		20		25	ns
t _{PU}	\overline{CE} LOW to Power-up	0		0		ns
t _{PD}	\overline{CE} HIGH to Power-up		55		70	ns
Write Cycle^[13]						
t _{WC}	Write Cycle Time	55		70		ns
t _{SCE}	\overline{CE} LOW to Write End	40		45		ns
t _{AW}	Address Set-up to Write End	40		45		ns
t _{HA}	Address Hold from Write End	0		0		ns
t _{SA}	Address Set-up to Write Start	0		0		ns
t _{PWE}	\overline{WE} Pulse Width	40		45		ns
t _{SD}	Data Set-up to Write End	25		30		ns
t _{HD}	Data Hold from Write End	0		0		ns
t _{HZWE}	\overline{WE} LOW to High Z ^[11, 12]		20		25	ns
t _{LZWE}	\overline{WE} HIGH to Low Z ^[11]	10		10		ns

Switching Waveforms

Read Cycle No. 1 (Address Transition Controlled)^[14, 15]

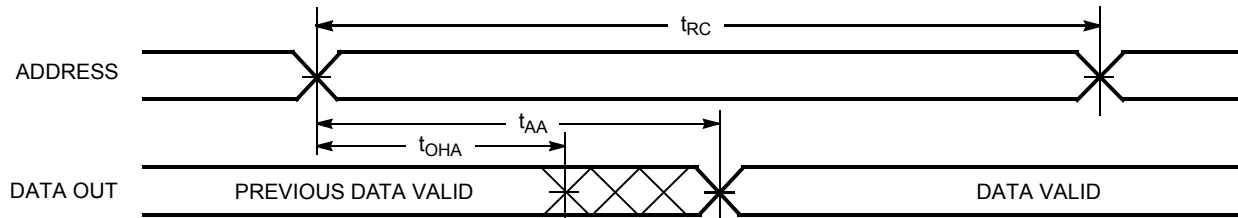

Notes:

10. Test Conditions for all parameters other than three-state parameters assume signal transition time of 3 ns or less (1 V/ns), timing reference levels of $V_{CC(typ)}/2$, input pulse levels of 0 to $V_{CC(typ)}$, and output loading of the specified I_{OL}/I_{OH} as shown in the "AC Test Loads and Waveforms" on page 4.
11. At any given temperature and voltage condition, t_{HZCE} is less than t_{LZCE} , t_{HZOE} is less than t_{LZOE} , and t_{HZWE} is less than t_{LZWE} for any given device.
12. t_{HZOE} , t_{HZCE} , and t_{HZWE} transitions are measured when the output enter a high impedance state.
13. The internal write time of the memory is defined by the overlap of \overline{WE} , $\overline{CE} = V_{IL}$. All signals must be ACTIVE to initiate a write and any of these signals can terminate a write by going INACTIVE. The data input set-up and hold timing should be referenced to the edge of the signal that terminates the write.
14. Device is continuously selected. \overline{OE} , $\overline{CE} = V_{IL}$.
15. \overline{WE} is HIGH for read cycle.

Switching Waveforms (continued)

Read Cycle No. 2 (\overline{OE} Controlled)^[15, 16]

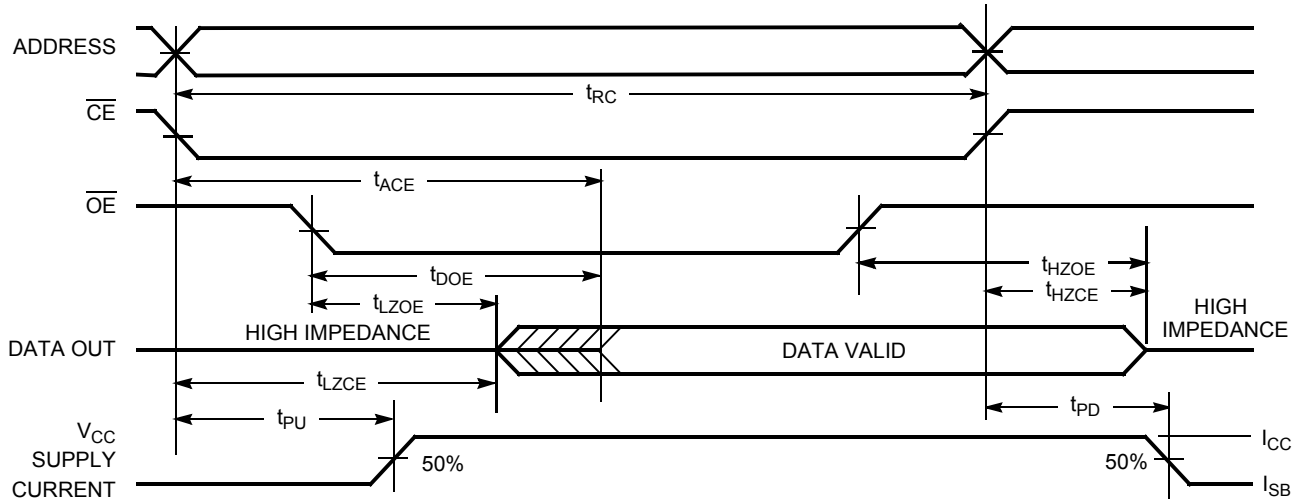

Write Cycle No. 1 (\overline{WE} Controlled)^[17, 18]

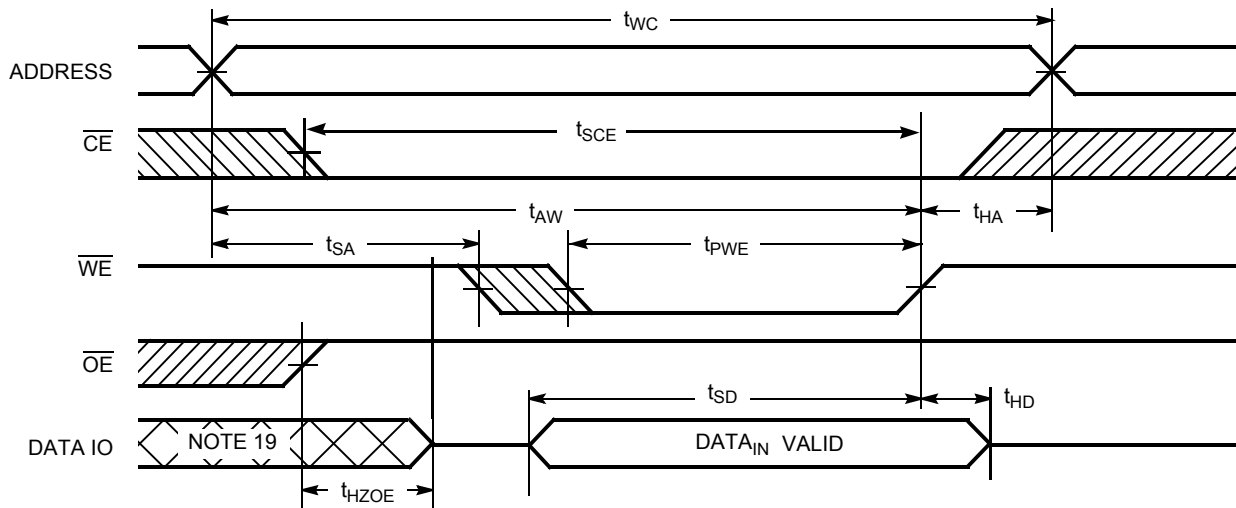

Notes:

- 16. Address valid prior to or coincident with \overline{CE} transition LOW.
- 17. Data IO is high impedance if $\overline{OE} = V_{IH}$.
- 18. If \overline{CE} goes HIGH simultaneously with \overline{WE} HIGH, the output remains in high-impedance state.
- 19. During this period, the IOs are in output state and input signals should not be applied.

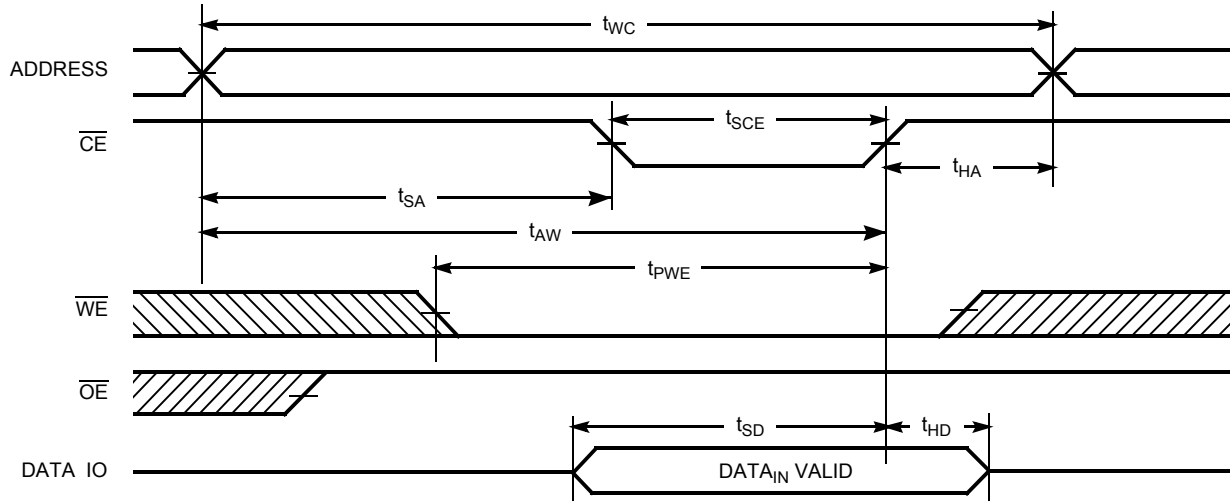
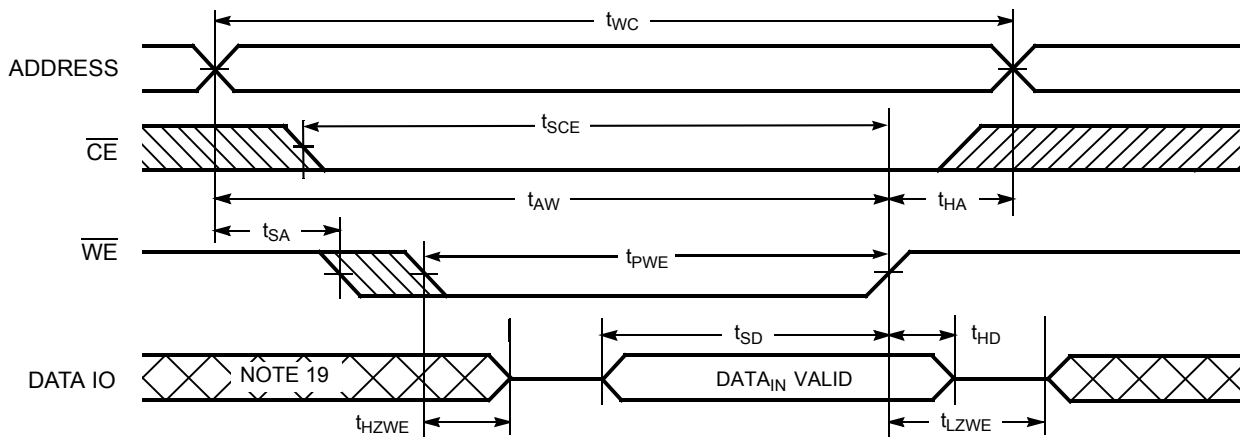
Switching Waveforms (continued)
Write Cycle No. 2 ($\overline{\text{CE}}$ Controlled)^[17, 18]

Write Cycle No. 3 ($\overline{\text{WE}}$ Controlled, $\overline{\text{OE}}$ LOW)^[18]

Truth Table

$\overline{\text{CE}}$	$\overline{\text{WE}}$	$\overline{\text{OE}}$	Inputs/Outputs	Mode	Power
H	X	X	High Z	Deselect/Power-down	Standby (I_{SB})
L	H	L	Data Out ($\text{IO}_0\text{-IO}_7$)	Read	Active (I_{CC})
L	H	H	High Z	Output Disabled	Active (I_{CC})
L	L	X	Data in ($\text{IO}_0\text{-IO}_7$)	Write	Active (I_{CC})

Ordering Information

Speed (ns)	Ordering Code	Package Diagram	Package Type	Operating Range
55	CY62148DV30LL-55BVI	51-85149	36-ball VFBGA (6 × 8 × 1 mm)	Industrial
	CY62148DV30LL-55BVXI		36-ball VFBGA (6 × 8 × 1 mm) (Pb-free)	
	CY62148DV30L-55ZSXI	51-85095	32-pin TSOP II (Pb-free)	
	CY62148DV30LL-55ZSXI			
	CY62148DV30LL-55SXI	51-85081	32-pin SOIC (Pb-free)	
70	CY62148DV30LL-70ZSXI	51-85095	32-pin TSOP II (Pb-free)	Industrial
	CY62148DV30LL-70ZSXA	51-85095	32-pin TSOP II (Pb-free)	Automotive-A

Contact your local Cypress sales representative for availability of these parts

Package Diagrams

Figure 1. 36-ball VFBGA (6 x 8 x 1 mm), 51-85149

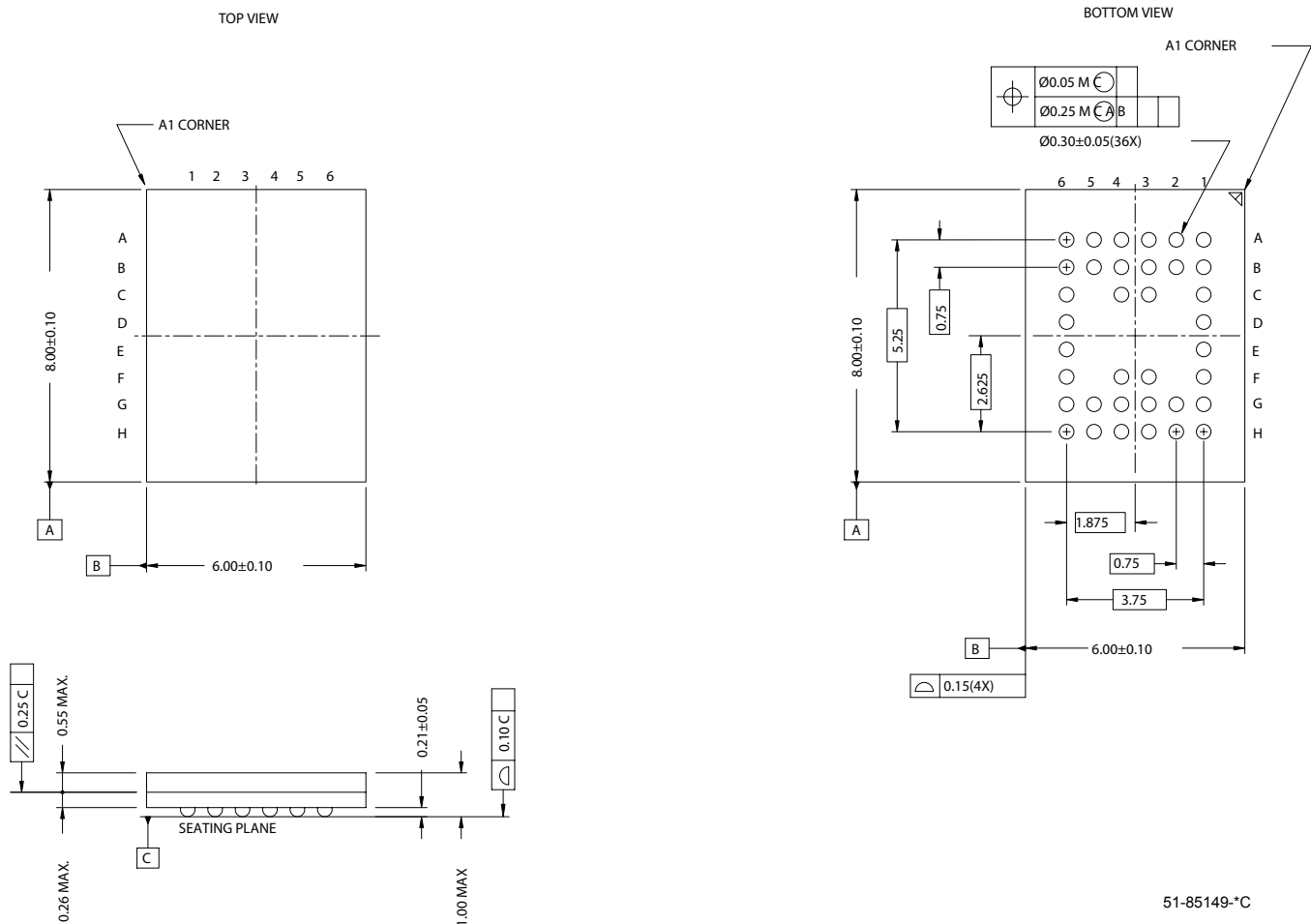

51-85149-^oC

Package Diagrams (continued)

Figure 2. 32-pin TSOP II, 51-85095

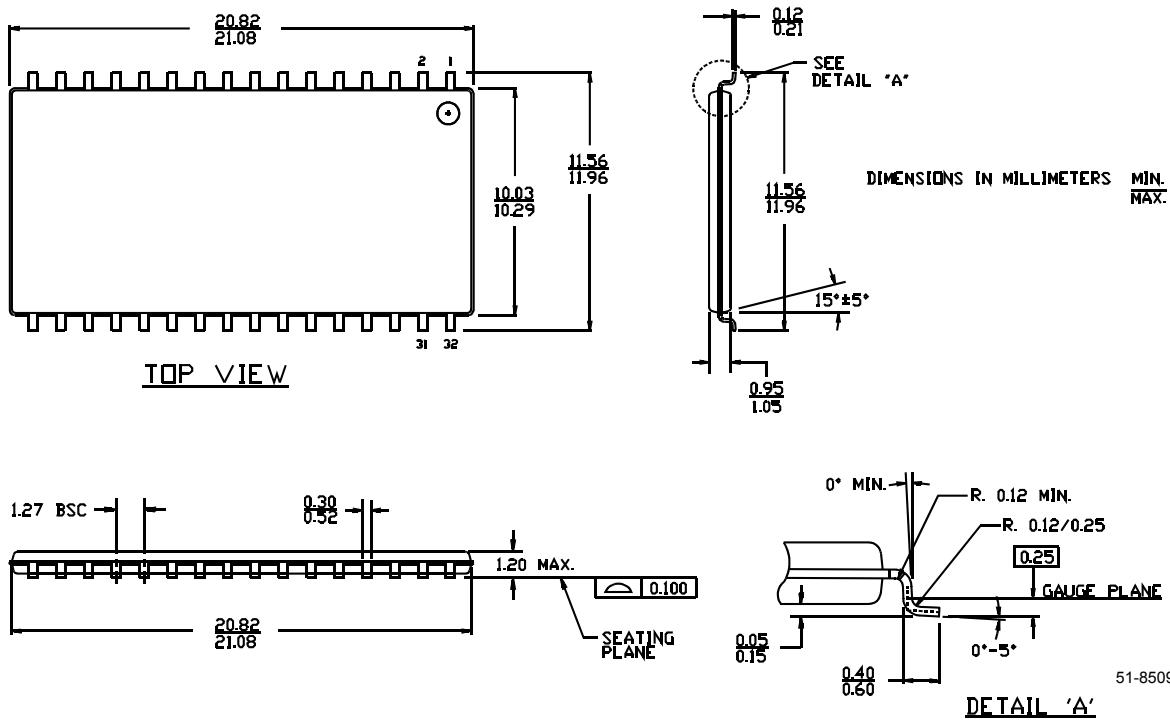
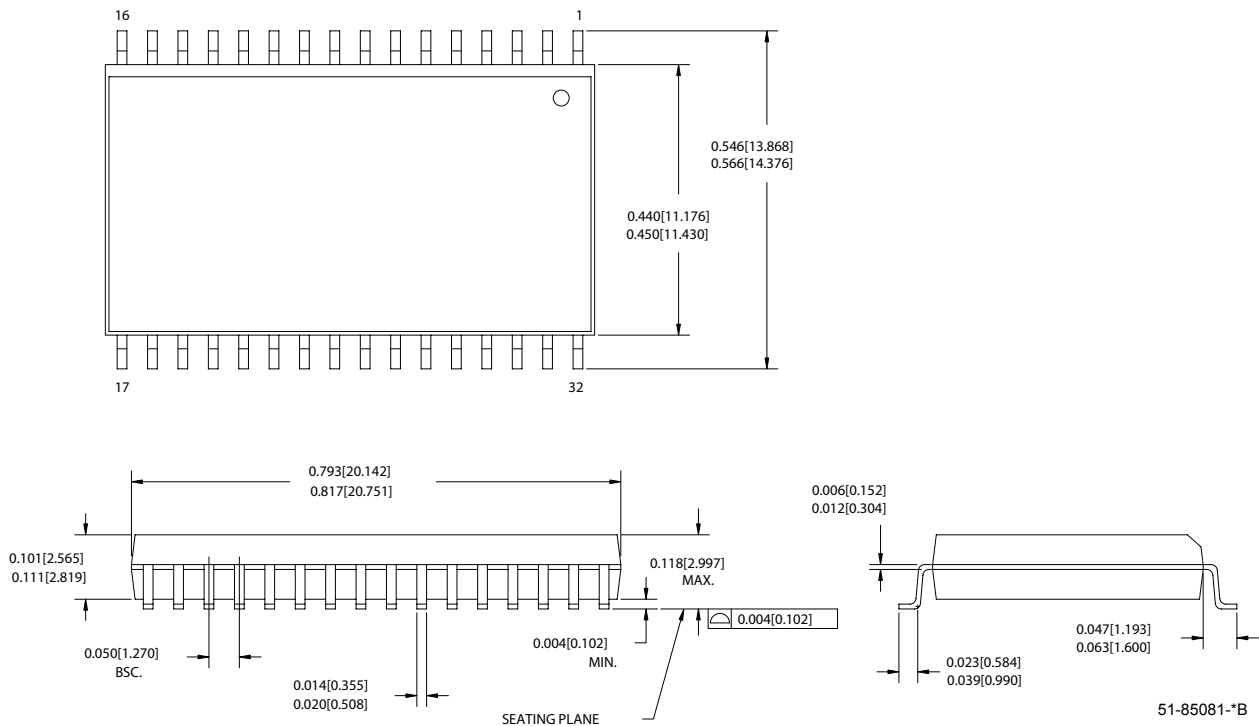

Figure 3. 32-pin (450 MIL) Molded SOIC, 51-85081



MoBL is a registered trademark, and More Battery Life is a trademark, of Cypress Semiconductor. All product and company names mentioned in this document may be the trademarks of their respective holders.

Document History Page

Document Title: CY62148DV30, 4-Mbit (512K x 8) MoBL [®] Static RAM				
Document Number: 38-05341				
REV.	ECN NO.	Issue Date	Orig. of Change	Description of Change
**	127480	06/17/03	HRT	Created new data sheet
*A	131041	01/23/04	CBD	Changed from Advance to Preliminary
*B	222180	See ECN	AJU	Changed from Preliminary to Final Added 70 ns speed bin Modified footnote #6 and #12 Removed MAX value for V _{DR} on "Data Retention Characteristics" table Modified input and output capacitance values Added Pb-free ordering information Removed 32-pin STSOP package
*C	498575	See ECN	NXR	Added Automotive-A Operating Range Removed SOIC package from Product Offering Updated Ordering Information Table
*D	729917	See ECN	VKN	Added SOIC package and its related information Updated Ordering Information Table

Looking for pricing, stock, or lifecycle information?

Click below to explore more details on WIN SOURCE:

 [View CY62148DV30LL-70ZSXA on WIN SOURCE](#)

 [Infineon Technologies](#) Information

Optimize Your Supply Chain with WIN SOURCE Solutions

-  Global Sourcing Solution
-  Obsolete Management
-  Cost Control Management
-  Shortage Management
-  Alternative Solution
-  Excess Inventory Management