



**THE DATASHEET OF  
ADS1298CZXGT**



# ADS129x Low-Power, 8-Channel, 24-Bit Analog Front-End for Biopotential Measurements

## 1 Features

- Eight Low-Noise PGAs and Eight High-Resolution ADCs (ADS1298, ADS1298R)
- Low Power: 0.75 mW/channel
- Input-Referred Noise: 4  $\mu\text{V}_{\text{PP}}$  (150 Hz BW, G = 6)
- Input Bias Current: 200 pA
- Data Rate: 250 SPS to 32 kSPS
- CMRR:  $-115$  dB
- Programmable Gain: 1, 2, 3, 4, 6, 8, or 12
- Supports systems meeting AAMI EC11, EC13, IEC60601-1, IEC60601-2-27, and IEC60601-2-51 Standards
- Unipolar or Bipolar Supplies:
  - AVDD = 2.7 V to 5.25 V
  - DVDD = 1.65 V to 3.6 V
- Built-In Right Leg Drive Amplifier, Lead-Off Detection, Wilson Center Terminal, Pace Detection, Test Signals
- Integrated Respiration Impedance Measurement
- Digital Pace Detection Capability
- Built-In Oscillator and Reference
- SPI™-Compatible Serial Interface

## 2 Applications

- Medical Instrumentation (ECG, EMG, and EEG): Patient Monitoring; Holter, Event, Stress, and Vital Signs Including ECG, AED, Telemedicine Bispectral Index (BIS), Evoked Audio Potential (EAP), Sleep Study Monitor

## 3 Description

The ADS1294, ADS1296, ADS1298 (ADS129x) and ADS1294R, ADS1296R, ADS1298R (ADS129xR) are a family of multichannel, simultaneous sampling, 24-bit, delta-sigma ( $\Delta\Sigma$ ) analog-to-digital converters (ADCs) with built-in programmable gain amplifiers (PGAs), internal reference, and an onboard oscillator. The ADS129x and ADS129xR incorporate all of the features that are commonly required in medical electrocardiogram (ECG) and electroencephalogram (EEG) applications. With high levels of integration and exceptional performance, the ADS129x and ADS129xR enables the development of scalable medical instrumentation systems at significantly reduced size, power, and overall cost.

The ADS129x and ADS129xR have a flexible input multiplexer (mux) per channel that can be independently connected to the internally-generated signals for test, temperature, and lead-off detection. Additionally, any configuration of input channels can be selected for derivation of the right leg drive (RLD) output signal. The ADS129x and ADS129xR operate at data rates as high as 32 kSPS, thereby allowing the implementation of software pace detection. Lead-off detection can be implemented internal to the device, either with a pullup or pulldown resistor, or an excitation current sink or source. Three integrated amplifiers generate the Wilson central terminal (WCT) and the Goldberger central terminals (GCT) required for a standard 12-lead ECG. The ADS129xR versions include a fully integrated, respiration impedance measurement function. Multiple ADS129x and ADS129xR devices can be cascaded in high channel count systems in a daisy-chain configuration.

Package options include a tiny 8-mm  $\times$  8-mm, 64-ball BGA, and a TQFP-64. The ADS129x BGA version is specified over the commercial temperature range of 0°C to 70°C. The ADS129xR BGA and ADS129x TQFP versions are specified over the industrial temperature range of  $-40^\circ\text{C}$  to  $+85^\circ\text{C}$ .

**Simplified Schematic**

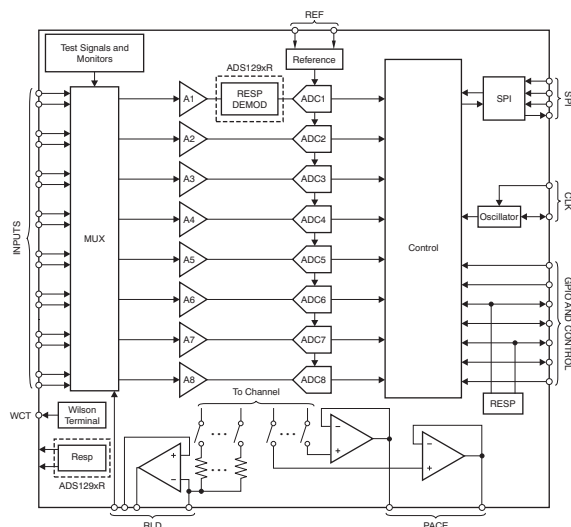

**Device Information<sup>(1)</sup>**

PART NUMBER	PACKAGE	BODY SIZE (NOM)
ADS129x, ADS129xR	NFBGA (64)	8.00 mm $\times$ 8.00 mm
	TQFP (64)	10.00 mm $\times$ 10.00 mm

(1) For all available packages, see the package option addendum at the end of the data sheet.



## Table of Contents

<b>1 Features</b> .....	<b>1</b>	9.4 Device Functional Modes .....	<b>51</b>
<b>2 Applications</b> .....	<b>1</b>	9.5 Programming .....	<b>59</b>
<b>3 Description</b> .....	<b>1</b>	9.6 Register Maps .....	<b>65</b>
<b>4 Revision History</b> .....	<b>2</b>	<b>10 Application and Implementation</b> .....	<b>84</b>
<b>5 Device Comparison</b> .....	<b>5</b>	10.1 Application Information .....	<b>84</b>
<b>6 Pin Configuration and Functions</b> .....	<b>6</b>	10.2 Typical Applications .....	<b>89</b>
<b>7 Specifications</b> .....	<b>12</b>	<b>11 Power Supply Recommendations</b> .....	<b>96</b>
7.1 Absolute Maximum Ratings .....	<b>12</b>	11.1 Power-Up Sequencing .....	<b>96</b>
7.2 ESD Ratings .....	<b>12</b>	11.2 Connecting to Unipolar (3 V or 1.8 V) Supplies .....	<b>97</b>
7.3 Recommended Operating Conditions .....	<b>12</b>	11.3 Connecting to Bipolar ( $\pm 1.5$ V or $\pm 1.8$ V) Supplies .....	<b>97</b>
7.4 Thermal Information .....	<b>13</b>	<b>12 Layout</b> .....	<b>98</b>
7.5 Electrical Characteristics .....	<b>13</b>	12.1 Layout Guidelines .....	<b>98</b>
7.6 Timing Requirements: Serial Interface .....	<b>17</b>	12.2 Layout Example .....	<b>99</b>
7.7 Switching Characteristics: Serial Interface .....	<b>17</b>	<b>13 Device and Documentation Support</b> .....	<b>100</b>
7.8 Typical Characteristics .....	<b>18</b>	13.1 Related Links .....	<b>100</b>
<b>8 Parameter Measurement Information</b> .....	<b>22</b>	13.2 Community Resources .....	<b>100</b>
8.1 Noise Measurements .....	<b>22</b>	13.3 Trademarks .....	<b>100</b>
<b>9 Detailed Description</b> .....	<b>24</b>	13.4 Electrostatic Discharge Caution .....	<b>100</b>
9.1 Overview .....	<b>24</b>	13.5 Glossary .....	<b>100</b>
9.2 Functional Block Diagram .....	<b>25</b>	<b>14 Mechanical, Packaging, and Orderable Information</b> .....	<b>100</b>
9.3 Feature Description .....	<b>26</b>		

## 4 Revision History

NOTE: Page numbers for previous revisions may differ from page numbers in the current version.

Changes from Revision J (January 2014) to Revision K	Page
• Added ESD Ratings table, Feature Description section, Device Functional Modes, Application and Implementation section, Power Supply Recommendations section, Layout section, Device and Documentation Support section, and Mechanical, Packaging, and Orderable Information section .....	<b>1</b>
• Changed text throughout data sheet for clarity .....	<b>1</b>
• Added note to DAISY_IN pin .....	<b>8</b>
• Added note to DAISY_IN pin .....	<b>10</b>
• Changed Equation 3 .....	<b>32</b>

Changes from Revision I (January 2012) to Revision J	Page
• Changed NC pin discription in Pin Assignments table .....	<b>10</b>
• Changed NC pin discription in Pin Assignments table .....	<b>10</b>
• Added graph of INTERNAL $V_{REF}$ DRIFT vs TEMPERATURE .....	<b>21</b>
• Changed order of subsections in the Theory of Operation section .....	<b>26</b>
• Changed single-ended input description to correct input range values .....	<b>30</b>
• Changed Figure 27 to show correct input range for single-ended inputs .....	<b>30</b>
• Changed Figure 28 to show correct input range for single-ended inputs .....	<b>30</b>
• Deleted text regarding large scale signal .....	<b>31</b>
• Changed Figure 32 to provide a more stable external reference driver circuit .....	<b>33</b>
• Updated Figure 57 .....	<b>51</b>
• Added Figure 58 .....	<b>52</b>
• Added discussion of SCLK/DRDY bus behavior to Data Ready (DRDY) section .....	<b>53</b>
• Added Figure 60 .....	<b>53</b>

• Added <i>status Word</i> section and <a href="#">Figure 61</a> to discuss the status word .....	53
• Added <i>Readback Length</i> section.....	53
• Added <i>SCLK Clocking Methods</i> section.....	60
• Changed units in TEST_AMP bit description in CONFIG2 register .....	68
• Changed <a href="#">Figure 93</a> to clarify Initial Flow at Power-Up .....	85
• Changed <i>Power-Up Sequencing</i> section text to clarify start-up timing .....	96
• Changed <a href="#">Figure 105</a> .....	96
• Changed power-up reset wait time in <a href="#">Table 38</a> .....	96

**Changes from Revision H (October 2011) to Revision I**
**Page**

• Added eighth Features bullet (list of standards supported).....	1
• Updated BGA pin out.....	6
• Deleted duplicate <i>Digital input voltage</i> and <i>Digital output voltage</i> rows from Absolute Maximum Ratings table.....	12
• Changed parameter name of Channel Performance, <i>Common-mode rejection ratio</i> and <i>Power-supply rejection ratio</i> parameters in Electrical Characteristics table .....	14
• Updated <a href="#">Functional Block Diagram</a> .....	25
• Updated description of <i>Analog Input</i> section.....	30
• Updated <a href="#">Figure 30</a> .....	32
• Updated <a href="#">Figure 33</a> .....	34
• Updated <a href="#">Figure 34</a> .....	35
• Changed description of START pin in <i>START</i> section.....	51
• Changed description of <i>Data Ready (<math>\overline{DRDY}</math>)</i> section .....	52
• Changed conversion description in <i>Single-Shot Mode</i> section .....	54
• Changed conversion description in <i>Continuous Mode</i> section.....	55
• Changed Unit column in <a href="#">Table 14</a> .....	55
• Added power-down recommendation to bit 7 description of <i>CHnSET: Individual Channel Settings</i> section.....	71
• Changed description of bit 5 in <i>RESP: Respiration Control Register</i> section .....	80
• Corrected name of bit 6 in <i>WCT2: Wilson Central Terminal Control Register</i> section.....	83

**Changes from Revision G (February 2011) to Revision H**
**Page**

• Changed footnote 1 of BGA Pin Assignments table .....	7
• Added footnote 1 cross-reference to <i>RLDIN</i> , <i>TESTP_PACE_OUT1</i> , and <i>TESTP_PACE_OUT</i> in BGA Pin Assignments table .....	7
• Changed footnote 1 of PAG Pin Assignments table .....	10
• Added footnote 1 cross-reference to <i>TESTP_PACE_OUT1</i> , <i>TESTP_PACE_OUT2</i> , and <i>RLDIN</i> in PAG Pin Assignments table .....	10
• Changed description of <i>AVSS</i> and <i>AVDD</i> in PAG Pin Assignments table .....	11
• Added ( <i>ADS1298</i> ) to <i>High-Resolution mode</i> and <i>Low-Power mode</i> test conditions of Supply Current section in Electrical Characteristics table .....	16
• Changed 3-V Power Dissipation, <i>Quiescent channel power</i> test conditions in <i>Electrical Characteristics</i> table .....	16
• Changed 5-V Power Dissipation, <i>Quiescent channel power</i> test conditions in <i>Electrical Characteristics</i> table .....	16
• Changed title of <a href="#">Figure 20</a> .....	20
• Updated <a href="#">Figure 42</a> .....	41
• Added new paragraph to <i>Respiration</i> section .....	46
• Updated <a href="#">Equation 5</a> .....	49
• Changed title of <a href="#">Table 13</a> .....	54

---

• Updated <a href="#">Figure 66</a> .....	57
• Changed description of <i>STANDBY: Enter STANDBY Mode</i> section .....	61
• Changed bit name for bits 5, 6, and 7 in ID register of <a href="#">Table 16</a> .....	65
• Changed bit name for bits 5, 6, and 7 in <i>ID: ID Control Register</i> section .....	66
• Added footnote to <a href="#">Figure 97</a> .....	89
• Changed description of solid ceramic capacitor in <i>Power Supplies and Grounding</i> section .....	96
• Changed description of <i>Connecting the Device to Bipolar (<math>\pm 1.5</math> V/1.8 V) Supplies</i> section .....	97

































































---

## 5 Device Comparison

PRODUCT	PACKAGE OPTIONS	OPERATING TEMPERATURE RANGE	RESPIRATION CIRCUITRY	CHANNELS	ADC RESOLUTION	MAXIMUM SAMPLING RATE
ADS1194	TQFP-64	0°C to 70°C	No	4	16	8 kSPS
	NFBGA-64	0°C to 70°C				
ADS1196	TQFP-64	0°C to 70°C	No	6	16	8 kSPS
	NFBGA-64	0°C to 70°C				
ADS1198	TQFP-64	0°C to 70°C	No	8	16	8 kSPS
	NFBGA-64	0°C to 70°C				
ADS1294	TQFP-64	–40°C to +85°C	External	4	24	32 kSPS
	NFBGA-64	0°C to 70°C				
ADS1294R	NFBGA-64	–40°C to +85°C	Yes			
ADS1296	TQFP-64	–40°C to +85°C	External	6	24	32 kSPS
	NFBGA-64	0°C to 70°C				
ADS1296R	NFBGA-64	–40°C to +85°C	Yes			
ADS1298	TQFP-64	–40°C to +85°C	External	8	24	32 kSPS
	NFBGA-64	0°C to 70°C				
ADS1298R	NFBGA-64	–40°C to +85°C	Yes			

## 6 Pin Configuration and Functions

**ZXG Package  
64-Pin NFBGA  
Top View, Solder Bumps on Bottom Side**

H	G	F	E	D	C	B	A	
IN1P 	IN2P 	IN3P 	IN4P 	IN5P 	IN6P 	IN7P 	IN8P 	1
IN1N 	IN2N 	IN3N 	IN4N 	IN5N 	IN6N 	IN7N 	IN8N 	2
VREFP 	VCAP4 	TESTN_ PACE_OUT2 	TESTP_ PACE_OUT1 	WCT 	RLDINV 	RLDOUT 	RLDIN 	3
VREFN 	RESP_ MODP 	RESP_ MODN 	RESV1 	AVSS 	RLDREF 	AVDD 	AVDD 	4
VCAP1 	$\overline{\text{PWDN}}$ 	GPIO1 	GPIO4 	AVSS 	AVSS 	AVSS 	AVSS 	5
VCAP2 	$\overline{\text{RESET}}$ 	DAISY_IN 	GPIO3 	$\overline{\text{DRDY}}$ 	AVDD 	AVDD 	AVDD 	6
DGND 	START 	$\overline{\text{CS}}$ 	GPIO2 	DGND 	DGND 	VCAP3 	AVDD1 	7
DIN 	CLK 	SCLK 	DOUT 	DVDD 	DVDD 	CLKSEL 	AVSS1 	8

**Pin Function: NFBGA Package**

PIN		TYPE	DESCRIPTION
NO.	NAME		
1A	IN8P <sup>(1)</sup>	Analog input	Differential analog positive input 8 (ADS1298 and ADS1298R)
1B	IN7P <sup>(1)</sup>	Analog input	Differential analog positive input 7 (ADS1298 and ADS1298R)
1C	IN6P <sup>(1)</sup>	Analog input	Differential analog positive input 6 (ADS1296, ADS1298, ADS1296R, ADS1298R)
1D	IN5P <sup>(1)</sup>	Analog input	Differential analog positive input 5 (ADS1296, ADS1298, ADS1296R, ADS1298R)
1E	IN4P <sup>(1)</sup>	Analog input	Differential analog positive input 4
1F	IN3P <sup>(1)</sup>	Analog input	Differential analog positive input 3
1G	IN2P <sup>(1)</sup>	Analog input	Differential analog positive input 2
1H	IN1P <sup>(1)</sup>	Analog input	Differential analog positive input 1
2A	IN8N <sup>(1)</sup>	Analog input	Differential analog negative input 8 (ADS1298, ADS1298R)
2B	IN7N <sup>(1)</sup>	Analog input	Differential analog negative input (ADS1298, ADS1298R)
2C	IN6N <sup>(1)</sup>	Analog input	Differential analog negative input 6 (ADS1296, ADS1298, ADS1296R, ADS1298R)
2D	IN5N <sup>(1)</sup>	Analog input	Differential analog negative input 5 (ADS1296, ADS1298, ADS1296R, ADS1298R)
2E	IN4N <sup>(1)</sup>	Analog input	Differential analog negative input 4
2F	IN3N <sup>(1)</sup>	Analog input	Differential analog negative input 3
2G	IN2N <sup>(1)</sup>	Analog input	Differential analog negative input 2
2H	IN1N <sup>(1)</sup>	Analog input	Differential analog negative input 1
3A	RLDIN <sup>(1)</sup>	Analog input	Right leg drive input to mux
3B	RLDOUT	Analog output	Right leg drive output
3C	RLDINV	Analog input/output	Right leg drive inverting input
3D	WCT	Analog output	Wilson central terminal output
3E	TESTP_PACE_OUT1 <sup>(1)</sup>	Analog input/buffer output	Internal test signal or single-ended buffer output based on register settings
3F	TESTN_PACE_OUT2 <sup>(1)</sup>	Analog input/output	Internal test signal or single-ended buffer output based on register settings
3G	VCAP4	—	Analog bypass capacitor; connect 1- $\mu$ F capacitor to AVSS
3H	VREFP	Analog input/output	Positive reference input/output voltage
4A	AVDD	Supply	Analog supply
4B	AVDD	Supply	Analog supply
4C	RLDREF	Analog input	Right leg drive noninverting input
4D	AVSS	Supply	Analog ground
4E	RESV1	Digital input	Reserved for future use; must tie to logic low (DGND).
4F	RESP_MODN	Analog output	ADS129xR: modulation clock for respiration measurement, negative side. ADS129x: leave floating.
4G	RESP_MODP	Analog output	ADS129xR: modulation clock for respiration measurement, positive side. ADS129x: leave floating.
4H	VREFN	Analog input	Negative reference voltage
5A	AVSS	Supply	Analog ground
5B	AVSS	Supply	Analog ground
5C	AVSS	Supply	Analog ground
5D	AVSS	Supply	Analog ground
5E	GPIO4	Digital input/output	General-purpose input/output pin 4
5F	GPIO1	Digital input/output	General-purpose input/output pin 1
5G	PWDN	Digital input	Power-down pin; active low

(1) Connect unused pins to AVDD.

**Pin Function: NFBGA Package (continued)**

PIN		TYPE	DESCRIPTION
NO.	NAME		
5H	VCAP1	—	Analog bypass capacitor; connect 22- $\mu$ F capacitor to AVSS
6A	AVDD	Supply	Analog supply
6B	AVDD	Supply	Analog supply
6C	AVDD	Supply	Analog supply
6D	$\overline{\text{DRDY}}$	Digital output	Data ready; active low
6E	GPIO3	Digital input/output	General purpose input/output pin 3
6F	DAISY_IN <sup>(2)</sup>	Digital input	Daisy-chain input; if not used, short to DGND.
6G	$\overline{\text{RESET}}$	Digital input	System-reset pin; active low
6H	VCAP2	—	Analog bypass capacitor; connect 1- $\mu$ F capacitor to AVSS
7A	AVDD1	Supply	Analog supply for charge pump
7B	VCAP3	—	Analog bypass capacitor; internally generated AVDD + 1.9 V; connect 1- $\mu$ F capacitor to AVSS
7C	DGND	Supply	Digital ground
7D	DGND	Supply	Digital ground
7E	GPIO2	Digital input/output	General-purpose input/output pin 2
7F	$\overline{\text{CS}}$	Digital input	SPI chip select; active low
7G	START	Digital input	Start conversion
7H	DGND	Supply	Digital ground
8A	AVSS1	Supply	Analog ground for charge pump
8B	CLKSEL	Digital input	Master clock select
8C	DVDD	Supply	Digital power supply
8D	DVDD	Supply	Digital power supply
8E	DOUT	Digital output	SPI data output
8F	SCLK	Digital input	SPI clock
8G	CLK	Digital input/output	External Master clock input or internal clock output.
8H	DIN	Digital input	SPI data input

(2) When DAISY\_IN is not used, tie to logic 0.

**PAG PACKAGE  
64-Pin TQFP  
Top View**

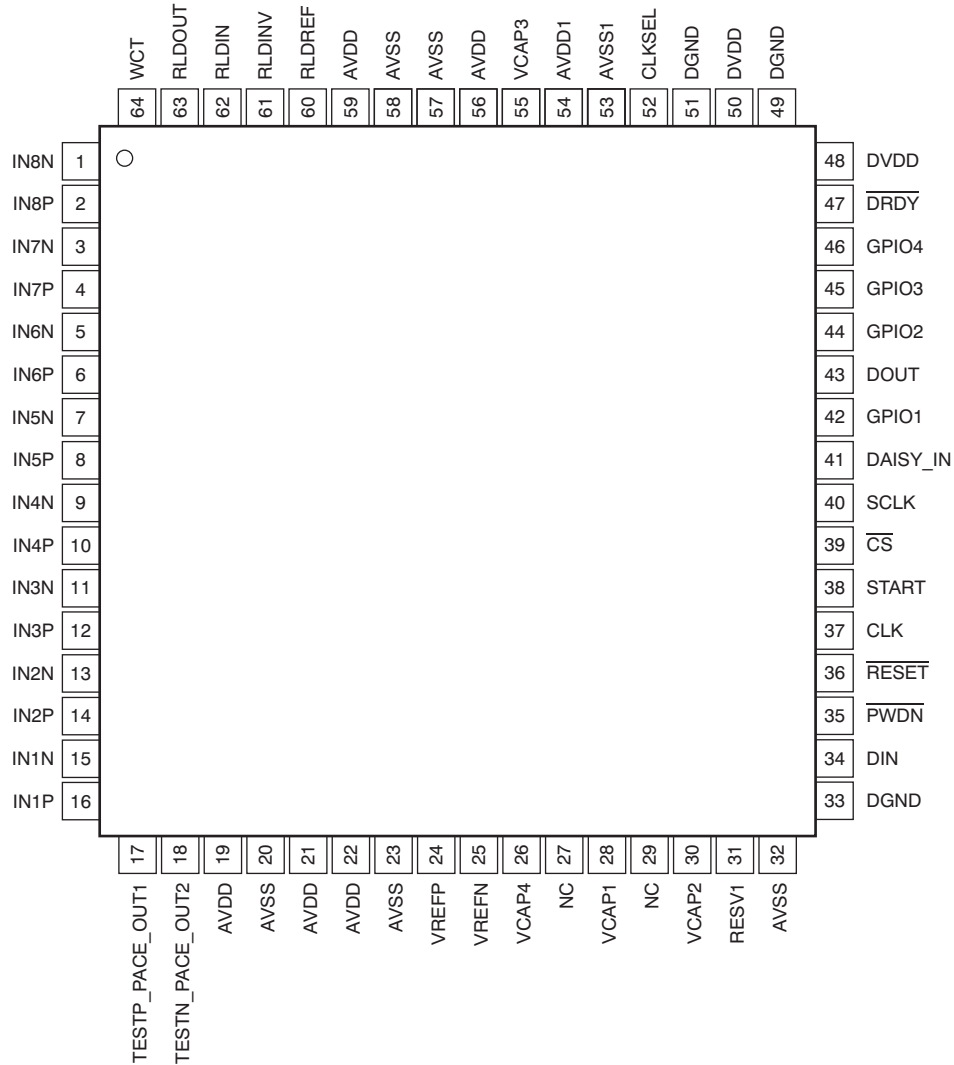

**Pin Functions: TQFP Package**

PIN		TYPE	DESCRIPTION
NO.	NAME		
1	IN8N <sup>(1)</sup>	Analog input	Differential analog negative input 8 (ADS1298)
2	IN8P <sup>(1)</sup>	Analog input	Differential analog positive input 8 (ADS1298)
3	IN7N <sup>(1)</sup>	Analog input	Differential analog negative input 7 (ADS1298)
4	IN7P <sup>(1)</sup>	Analog input	Differential analog positive input 7 (ADS1298)
5	IN6N <sup>(1)</sup>	Analog input	Differential analog negative input 6 (ADS1296, ADS1298)
6	IN6P <sup>(1)</sup>	Analog input	Differential analog positive input 6 (ADS1296, ADS1298)
7	IN5N <sup>(1)</sup>	Analog input	Differential analog negative input 5 (ADS1296, ADS1298)
8	IN5P <sup>(1)</sup>	Analog input	Differential analog positive input 5 (ADS1296, ADS1298)
9	IN4N <sup>(1)</sup>	Analog input	Differential analog negative input 4
10	IN4P <sup>(1)</sup>	Analog input	Differential analog positive input 4
11	IN3N <sup>(1)</sup>	Analog input	Differential analog negative input 3
12	IN3P <sup>(1)</sup>	Analog input	Differential analog positive input 3
13	IN2N <sup>(1)</sup>	Analog input	Differential analog negative input 2
14	IN2P <sup>(1)</sup>	Analog input	Differential analog positive input 2
15	IN1N <sup>(1)</sup>	Analog input	Differential analog negative input 1
16	IN1P <sup>(1)</sup>	Analog input	Differential analog positive input 1
17	TESTP_PACE_OUT1 <sup>(1)</sup>	Analog input/buffer output	Internal test signal/single-ended buffer output based on register settings
18	TESTN_PACE_OUT2 <sup>(1)</sup>	Analog input/output	Internal test signal/single-ended buffer output based on register settings
19	AVDD	Supply	Analog supply
20	AVSS	Supply	Analog ground
21	AVDD	Supply	Analog supply
22	AVDD	Supply	Analog supply
23	AVSS	Supply	Analog ground
24	VREFP	Analog input/output	Positive reference input/output voltage
25	VREFN	Analog input	Negative reference voltage
26	VCAP4	—	Analog bypass capacitor; connect 1- $\mu$ F capacitor to AVSS
27	NC	—	No connection, can be connected to AVDD or AVSS with a 10-k $\Omega$ resistor
28	VCAP1	—	Analog bypass capacitor; connect 22- $\mu$ F capacitor to AVSS
29	NC	—	No connection, can be connected to AVDD or AVSS with a 10-k $\Omega$ resistor
30	VCAP2	—	Analog bypass capacitor; connect 1- $\mu$ F capacitor to AVSS
31	RESV1	Digital input	Reserved for future use; must tie to logic low (DGND).
32	AVSS	Supply	Analog ground
33	DGND	Supply	Digital ground
34	DIN	Digital input	SPI data input
35	$\overline{\text{PWDN}}$	Digital input	Power-down pin; active low
36	$\overline{\text{RESET}}$	Digital input	System-reset pin; active low
37	CLK	Digital input/output	External Master clock input or internal clock output.
38	START	Digital input	Start conversion
39	$\overline{\text{CS}}$	Digital input	SPI chip select; active low
40	SCLK	Digital input	SPI clock
41	DAISY_IN <sup>(2)</sup>	Digital input	Daisy-chain input; if not used, short to DGND.

(1) Connect unused pins to AVDD.

(2) When DAISY\_IN is not used, tie to logic 0.

**Pin Functions: TQFP Package (continued)**

PIN		TYPE	DESCRIPTION
NO.	NAME		
42	GPIO1	Digital input/output	General-purpose input/output pin 1
43	DOUT	Digital output	SPI data output
44	GPIO2	Digital input/output	General-purpose input/output pin 2
45	GPIO3	Digital input/output	General-purpose input/output pin 3
46	GPIO4	Digital input/output	General-purpose input/output pin 4
47	$\overline{\text{DRDY}}$	Digital output	Data ready; active low
48	DVDD	Supply	Digital power supply
49	DGND	Supply	Digital ground
50	DVDD	Supply	Digital power supply
51	DGND	Supply	Digital ground
52	CLKSEL	Digital input	Master clock select
53	AVSS1	Supply	Analog ground
54	AVDD1	Supply	Analog supply
55	VCAP3	—	Analog bypass capacitor; internally generated AVDD + 1.9 V; connect 1- $\mu\text{F}$ capacitor to AVSS
56	AVDD	Supply	Analog supply
57	AVSS	Supply	Analog ground
58	AVSS	Supply	Analog ground
59	AVDD	Supply	Analog supply
60	RLDREF	Analog input	Right leg drive noninverting input
61	RLDINV	Analog input/output	Right leg drive inverting input
62	RLDIN <sup>(1)</sup>	Analog input	Right leg drive input to mux
63	RLDOUT	Analog output	Right leg drive output
64	WCT	Analog output	Wilson Central Terminal output

## 7 Specifications

### 7.1 Absolute Maximum Ratings

over operating free-air temperature range (unless otherwise noted)<sup>(1)</sup>

	MIN	MAX	UNIT
AVDD to AVSS	-0.3	5.5	V
DVDD to DGND	-0.3	3.9	V
AVSS to DGND	-3	0.2	V
VREFP input to AVSS	AVSS - 0.3	AVDD + 0.3	V
Analog input voltage	AVSS - 0.3	AVDD + 0.3	V
Digital input voltage	DGND - 0.3	DVDD + 0.3	V
Digital output voltage	DGND - 0.3	DVDD + 0.3	V
Input current (momentary)		100	mA
Input current (continuous)		10	mA
Junction temperature, T <sub>J</sub>	-40	150	°C
Storage temperature, T <sub>stg</sub>	-60	150	°C

- (1) Stresses beyond those listed under *Absolute Maximum Ratings* may cause permanent damage to the device. These are stress ratings only, which do not imply functional operation of the device at these or any other conditions beyond those indicated under *Recommended Operating Conditions*. Exposure to absolute-maximum-rated conditions for extended periods may affect device reliability.

### 7.2 ESD Ratings

		VALUE	UNIT
V <sub>(ESD)</sub>	Electrostatic discharge	Human body model (HBM), per ANSI/ESDA/JEDEC JS-001, all pins <sup>(1)</sup>	±2000
		Charged device model (CDM), per JEDEC specification JESD22-C101, all pins <sup>(2)</sup>	±500

- (1) JEDEC document JEP155 states that 500-V HBM allows safe manufacturing with a standard ESD control process.  
 (2) JEDEC document JEP157 states that 250-V CDM allows safe manufacturing with a standard ESD control process.

### 7.3 Recommended Operating Conditions

over operating ambient temperature range (unless otherwise noted)

		MIN	NOM	MAX	UNIT	
<b>POWER SUPPLY</b>						
Analog power supply (AVDD - AVSS)		2.7	3	5.25	V	
Digital power supply (DVDD)		1.65	1.8	3.6	V	
AVDD - DVDD		-2.1		3.6	V	
<b>ANALOG INPUTS</b>						
Full-scale differential input voltage range (AINP - AINN)		±V <sub>REF</sub> / Gain			V	
Common-mode input voltage		See the <a href="#">Input Common-Mode Range</a> subsection of the <a href="#">PGA Settings and Input Range</a> section				
<b>VOLTAGE REFERENCE INPUTS</b>						
Differential reference voltage	3-V supply V <sub>REF</sub> = (VREFP - VREFN)	2.5			V	
	5-V supply V <sub>REF</sub> = (VREFP - VREFN)	4			V	
Negative input (VREFN)		AVSS			V	
Positive input (VREFP)		AVSS + 2.5			V	
<b>CLOCK INPUT</b>						
External clock input frequency	CLKSEL pin = 0	1.94	2.048	2.25	MHz	
<b>DIGITAL INPUTS</b>						
Input Voltage		DGND		DVDD	V	
<b>TEMPERATURE RANGE</b>						
Operating temperature range	Commercial grade	0			70	°C
	Industrial grade	-40			85	°C

## 7.4 Thermal Information

THERMAL METRIC <sup>(1)</sup>		ADS129x, ADS129xR		UNIT
		PAG (TQFP)	ZXG (NFBGA)	
		64 PINS	64 PINS	
R <sub>θJA</sub>	Junction-to-ambient thermal resistance	35	48	°C/W
R <sub>θJC(top)</sub>	Junction-to-case (top) thermal resistance	31	8	°C/W
R <sub>θJB</sub>	Junction-to-board thermal resistance	26	25	°C/W
ψ <sub>JT</sub>	Junction-to-top characterization parameter	0.1	0.5	°C/W
ψ <sub>JB</sub>	Junction-to-board characterization parameter	N/A	22	°C/W

- (1) For more information about traditional and new thermal metrics, see the *Semiconductor and IC Package Thermal Metrics* application report, [SPRA953](#).

## 7.5 Electrical Characteristics

Min and max specifications apply for all commercial grade (T<sub>A</sub> = 0°C to 70°C) devices, and from T<sub>A</sub> = –40°C to +85°C for industrial-grade devices. Typical specifications at T<sub>A</sub> = 25°C. All specifications at DVDD = 1.8 V, AVDD – AVSS = 3 V<sup>(1)</sup>, V<sub>REF</sub> = 2.4 V, external f<sub>CLK</sub> = 2.048 MHz, data rate = 500 SPS, HR mode<sup>(2)</sup>, and gain = 6 (unless otherwise noted).

PARAMETER	TEST CONDITIONS	MIN	TYP	MAX	UNIT
<b>ANALOG INPUTS</b>					
Input capacitance			20		pF
Input bias current	T <sub>A</sub> = 25°C, input = 1.5 V			±200	pA
	T <sub>A</sub> = 0°C to 70°C, input = 1.5 V		±1		nA
	T <sub>A</sub> = –40°C to +85°C, input = 1.5 V		±1.2		nA
DC input impedance	No lead-off	1000			MΩ
	Current source lead-off detection		500		MΩ
	Pullup resistor lead-off detection		10		MΩ
<b>PGA PERFORMANCE</b>					
Gain settings		1, 2, 3, 4, 6, 8, 12			
Bandwidth		See <a href="#">Table 5</a>			
<b>ADC PERFORMANCE</b>					
Resolution	Data rates up to 8 kSPS, no missing codes	24			Bits
	16-kSPS data rate	19			Bits
	32-kSPS data rate	17			Bits
Data rate	f <sub>CLK</sub> = 2.048 MHz, HR mode	500		32000	SPS
	f <sub>CLK</sub> = 2.048 MHz, LP mode	250		16000	SPS
<b>DC CHANNEL PERFORMANCE</b>					
Input-referred noise	Gain = 6 <sup>(3)</sup> , 10 seconds of data		5		μV <sub>PP</sub>
	Gain = 6, 256 points, 0.5 seconds of data		4	7	μV <sub>PP</sub>
	Gain settings ≠ 6, data rates ≠ 500 SPS	See <a href="#">Noise Measurements</a> section			
Integral nonlinearity <sup>(4)</sup>	Full-scale with gain = 6, best fit		8		ppm
	Full-scale with gain = 6, best fit, ADS129xR channel 1		40		ppm
	–20 dBFS with gain = 6, best fit, ADS129xR channel 1		8		ppm
Offset error			±500		μV
Offset error drift			2		μV/°C
Gain error	Excluding voltage reference error		±0.2	±0.5	% of FS
Gain drift	Excluding voltage reference drift		5		ppm/°C
Gain match between channels			0.3		% of FS

- (1) Performance is applicable for 5-V operation as well. Production testing for limits is performed at 3 V.  
 (2) LP mode = low-power mode.  
 (3) Noise data measured in a 10-second interval. Test not performed in production. Input-referred noise is calculated with input shorted (without electrode resistance) over a 10-second interval.  
 (4) The presence of internal demodulation circuitry on channel 1 causes degradation of INL and THD. The effect is pronounced for full-scale signals and is less for small ECG-type signals.

## Electrical Characteristics (continued)

Min and max specifications apply for all commercial grade ( $T_A = 0^\circ\text{C}$  to  $70^\circ\text{C}$ ) devices, and from  $T_A = -40^\circ\text{C}$  to  $+85^\circ\text{C}$  for industrial-grade devices. Typical specifications at  $T_A = 25^\circ\text{C}$ . All specifications at  $DVDD = 1.8\text{ V}$ ,  $AVDD - AVSS = 3\text{ V}^{(1)}$ ,  $V_{REF} = 2.4\text{ V}$ , external  $f_{CLK} = 2.048\text{ MHz}$ , data rate = 500 SPS, HR mode<sup>(2)</sup>, and gain = 6 (unless otherwise noted).

PARAMETER		TEST CONDITIONS	MIN	TYP	MAX	UNIT
<b>AC CHANNEL PERFORMANCE</b>						
CMRR	Common-mode rejection ratio	$f_{CM} = 50\text{ Hz}, 60\text{ Hz}^{(5)}$	-105	-115		dB
PSRR	Power-supply rejection ratio	$f_{PS} = 50\text{ Hz}, 60\text{ Hz}$		90		dB
	Crosstalk	$f_{IN} = 50\text{ Hz}, 60\text{ Hz}$		-126		dB
SNR	Signal-to-noise ratio	$f_{IN} = 10\text{ Hz}$ input, gain = 6		112		dB
THD	Total harmonic distortion <sup>(4)</sup>	10 Hz, -0.5 dBFs		-98		dB
		ADS129xR channel 1, 10 Hz, -0.5 dBFs		-70		dB
		100 Hz, -0.5 dBFs <sup>(6)</sup>		-100		dB
		ADS129xR channel 1, 100 Hz, -0.5 dBFs <sup>(6)</sup>		-68		dB
		ADS129xR channel 1, 100 Hz, -20 dBFs <sup>(6)</sup>		-86		dB
<b>DIGITAL FILTER</b>						
	-3-dB bandwidth			$0.262 f_{DR}$		Hz
	Digital filter settling	Full setting		4		Conversions
<b>RIGHT LEG DRIVE (RLD) AMPLIFIER AND PACE AMPLIFIERS</b>						
	RLD integrated noise	$BW = 150\text{ Hz}$		7		$\mu\text{V}_{RMS}$
	Pace integrated noise	$BW = 8\text{ kHz}$		20		$\mu\text{V}_{RMS}$
	Pace-amplifier crosstalk	Crosstalk between pace amplifiers		60		dB
	Gain bandwidth product	$50\text{ k}\Omega \parallel 10\text{ pF}$ load, gain = 1		100		kHz
	Slew rate	$50\text{ k}\Omega \parallel 10\text{ pF}$ load, gain = 1		0.25		$\text{V}/\mu\text{s}$
	Pace and RLD amplifier drive strength	Short circuit to GND ( $AVDD = 3\text{ V}$ )		270		$\mu\text{A}$
		Short circuit to supply ( $AVDD = 3\text{ V}$ )		550		$\mu\text{A}$
		Short circuit to GND ( $AVDD = 5\text{ V}$ )		490		$\mu\text{A}$
		Short circuit to supply ( $AVDD = 5\text{ V}$ )		810		$\mu\text{A}$
	Pace and RLD current	Peak swing ( $AVSS + 0.3\text{ V}$ to $AVDD + 0.3\text{ V}$ ) at $AVDD = 3\text{ V}$		50		$\mu\text{A}$
		Peak swing ( $AVSS + 0.3\text{ V}$ to $AVDD + 0.3\text{ V}$ ) at $AVDD = 5\text{ V}$		75		$\mu\text{A}$
	Pace-amplifier output resistance			100		$\Omega$
	Total harmonic distortion	$f_{IN} = 100\text{ Hz}$ , gain = 1		-70		dB
	Common-mode input range		$AVSS + 0.7$		$AVDD - 0.3$	V
	Common-mode resistor matching	Internal 200-k $\Omega$ resistor matching		0.1%		
	Short-circuit current			$\pm 0.25$		mA
	Quiescent power consumption	Either RLD or pace amplifier		20		$\mu\text{A}$
<b>WILSON CENTRAL TERMINAL (WCT) AMPLIFIER</b>						
	Integrated noise	$BW = 150\text{ Hz}$		See Table 6		$\text{nV}/\sqrt{\text{Hz}}$
	Gain bandwidth product			See Table 6		kHz
	Slew rate			See Table 6		$\text{V}/\text{s}$
	Total harmonic distortion	$f_{IN} = 100\text{ Hz}$		90		dB
	Common-mode input range		$AVSS + 0.3$		$AVDD - 0.3$	V
	Short-circuit current	Through internal 30-k $\Omega$ resistor		$\pm 0.25$		mA
	Quiescent power consumption			See Table 6		$\mu\text{A}$

(5) CMRR is measured with a common-mode signal of  $AVSS + 0.3\text{ V}$  to  $AVDD - 0.3\text{ V}$ . The values indicated are the maximum of the eight channels.

(6) Harmonics above the second harmonic are attenuated by the digital filter.

## Electrical Characteristics (continued)

Min and max specifications apply for all commercial grade ( $T_A = 0^\circ\text{C}$  to  $70^\circ\text{C}$ ) devices, and from  $T_A = -40^\circ\text{C}$  to  $+85^\circ\text{C}$  for industrial-grade devices. Typical specifications at  $T_A = 25^\circ\text{C}$ . All specifications at  $DVDD = 1.8\text{ V}$ ,  $AVDD - AVSS = 3\text{ V}^{(1)}$ ,  $V_{REF} = 2.4\text{ V}$ , external  $f_{CLK} = 2.048\text{ MHz}$ , data rate = 500 SPS, HR mode<sup>(2)</sup>, and gain = 6 (unless otherwise noted).

PARAMETER	TEST CONDITIONS	MIN	TYP	MAX	UNIT
<b>LEAD-OFF DETECT</b>					
Frequency	See Table 16 for settings	0, $f_{DR}/4$			kHz
Current	See Table 16 for settings	6, 12, 18, 24			nA
Current accuracy		$\pm 20\%$			
Comparator threshold accuracy		$\pm 30$			mV
<b>RESPIRATION (ADS129xR ONLY)</b>					
Frequency	Internal source	32, 64			kHz
	External source	32		64	kHz
Phase shift	See Table 16 for settings	22.5	90	157.5	Degrees
Impedance range	$I_{RESP} = 30\ \mu\text{A}$			10	k $\Omega$
Impedance measurement noise	0.05-Hz to 2-Hz brick wall filter, 32-kHz modulation clock, phase = 112.5, $I_{RESP} = 30\ \mu\text{A}$ with 2-k $\Omega$ baseline load, gain = 4	20			m $\Omega_{PP}$
Modulator current	internal reference, signal path = 82 k $\Omega$ , baseline = 2.21 k $\Omega$	29			$\mu\text{A}$
<b>EXTERNAL REFERENCE</b>					
Input impedance		10			k $\Omega$
<b>INTERNAL REFERENCE</b>					
Output voltage	Register bit CONFIG3.VREF_4V = 0, $AVDD \geq 2.7\text{ V}$	2.4			V
	Register bit CONFIG3.VREF_4V = 1, $AVDD \geq 4.4\text{ V}$	4			V
$V_{REF}$ accuracy		$\pm 0.2\%$			
Internal reference drift	$T_A = 25^\circ\text{C}$	35			ppm/ $^\circ\text{C}$
	Commercial grade, $0^\circ\text{C}$ to $70^\circ\text{C}$	35			ppm
	Industrial grade, $-40^\circ\text{C}$ to $85^\circ\text{C}$	45			ppm
Start-up time		150			ms
<b>SYSTEM MONITORS</b>					
Analog-supply reading error		2%			
Digital-supply reading error		2%			
Device wakeup	From power up to $\overline{\text{DRDY}}$ low	150			ms
	STANDBY mode	9			ms
Temperature-sensor reading, voltage	$T_A = 25^\circ\text{C}$	145			mV
Temperature-sensor reading, coefficient		490			$\mu\text{V}/^\circ\text{C}$
Test-signal frequency	See Table 16 for settings	$f_{CLK} / 2^{21}$ , $f_{CLK} / 2^{20}$			Hz
Test-signal voltage	See Table 16 for settings	$\pm 1$ , $\pm 2$			mV
Test-signal accuracy		$\pm 2\%$			
<b>CLOCK</b>					
Internal-oscillator clock frequency	Nominal frequency	2.048			MHz
Internal clock accuracy	$T_A = 25^\circ\text{C}$			$\pm 0.5\%$	
	$0^\circ\text{C} \leq T_A \leq 70^\circ\text{C}$			$\pm 2\%$	
	$-40^\circ\text{C} \leq T_A \leq 85^\circ\text{C}$ , industrial grade versions only			$\pm 2.5\%$	
Internal-oscillator start-up time				20	$\mu\text{s}$
Internal-oscillator power consumption		120			$\mu\text{W}$

## Electrical Characteristics (continued)

Min and max specifications apply for all commercial grade ( $T_A = 0^\circ\text{C}$  to  $70^\circ\text{C}$ ) devices, and from  $T_A = -40^\circ\text{C}$  to  $+85^\circ\text{C}$  for industrial-grade devices. Typical specifications at  $T_A = 25^\circ\text{C}$ . All specifications at  $DVDD = 1.8\text{ V}$ ,  $AVDD - AVSS = 3\text{ V}^{(1)}$ ,  $V_{REF} = 2.4\text{ V}$ , external  $f_{CLK} = 2.048\text{ MHz}$ , data rate = 500 SPS, HR mode<sup>(2)</sup>, and gain = 6 (unless otherwise noted).

PARAMETER		TEST CONDITIONS		MIN	TYP	MAX	UNIT
<b>DIGITAL INPUT/OUTPUT (DVDD = 1.65 V to 3.6 V)</b>							
$V_{IH}$	High-level input voltage			0.8 DVDD		DVDD + 0.1	V
$V_{IL}$	Low-level input voltage			-0.1		0.2 DVDD	V
$V_{OH}$	High-level output voltage	$I_{OH} = -500\ \mu\text{A}$		DVDD - 0.4			V
$V_{OL}$	Low-level output voltage	$I_{OL} = 500\ \mu\text{A}$				0.4	V
$I_{IN}$	Input current	$0\text{ V} < V_{\text{DigitalInput}} < DVDD$		-10		10	$\mu\text{A}$
<b>POWER SUPPLY (RLD, WCT, AND PACE AMPLIFIERS TURNED OFF)</b>							
$I_{AVDD}$	AVDD current	AVDD - AVSS = 3 V	HR mode (ADS1298)		2.75		mA
			LP mode <sup>(2)</sup> (ADS1298)		1.8		mA
		AVDD - AVSS = 5 V	HR mode (ADS1298)		3.1		mA
			LP mode (ADS1298)		2.1		mA
$I_{DVDD}$	DVDD current	DVDD = 1.8 V	HR mode (ADS1298)		0.3		mA
			LP mode (ADS1298)		0.3		mA
		DVDD = 3 V	HR mode (ADS1298)		0.5		mA
			LP mode (ADS1298)		0.5		mA
Power dissipation		ADS1298, ADS1298R, AVDD - AVSS = 3 V	HR mode		8.8	9.5	mW
			LP mode (250 SPS)		6.0	7.0	mW
		ADS1296, ADS1296R, AVDD - AVSS = 3 V	HR mode		7.2	7.9	mW
			LP mode (250 SPS)		5.3	6.6	mW
		ADS1294, ADS1294R, AVDD - AVSS = 3 V	HR mode		5.4	6	mW
			LP mode (250 SPS)		4.1	4.4	mW
		ADS1298, ADS1298R, AVDD - AVSS = 5 V	HR mode		17.5		mW
			LP mode (250 SPS)		12.5		mW
		ADS1296, ADS1296R, AVDD - AVSS = 5 V	HR mode		14.1		mW
			LP mode (250 SPS)		10		mW
		ADS1294, ADS1294R, AVDD - AVSS = 5 V	HR mode		10.1		mW
			LP mode (250 SPS)		8.3		mW
Power-down		AVDD - AVSS = 3 V			10		$\mu\text{W}$
		AVDD - AVSS = 5 V			20		$\mu\text{W}$
Standby mode		AVDD - AVSS = 3 V			2		mW
		AVDD - AVSS = 5 V			4		mW
Quiescent channel power		AVDD - AVSS = 3 V, PGA + ADC			818		$\mu\text{W}$
		AVDD - AVSS = 5 V, PGA + ADC			1.5		mW

### 7.6 Timing Requirements: Serial Interface

specifications apply from  $T_A = -40^{\circ}\text{C}$  to  $+85^{\circ}\text{C}$  (unless otherwise noted); load on  $D_{OUT} = 20\text{ pF} \parallel 100\text{ k}\Omega$

		2.7 V ≤ DVDD ≤ 3.6 V		1.65 V ≤ DVDD ≤ 2 V		UNIT
		MIN	MAX	MIN	MAX	
$t_{CLK}$	Master clock period	414	514	414	514	ns
$t_{CSSC}$	$\overline{CS}$ low to first SCLK, setup time	6		17		ns
$t_{SCLK}$	SCLK period	50		66.6		ns
$t_{SPWH, L}$	SCLK pulse width, high and low	15		25		ns
$t_{DIST}$	DIN valid to SCLK falling edge: setup time	10		10		ns
$t_{DIHD}$	Valid DIN after SCLK falling edge: hold time	10		11		ns
$t_{CSH}$	$\overline{CS}$ high pulse	2		2		$t_{CLK}$
$t_{SCCS}$	Eighth SCLK falling edge to $\overline{CS}$ high	4		4		$t_{CLK}$
$t_{SDECODE}$	Command decode time	4		4		$t_{CLK}$
$t_{DISCK2ST}$	DAISY_IN valid to SCLK rising edge: setup time	10		10		ns
$t_{DISCK2HT}$	DAISY_IN valid after SCLK rising edge: hold time	10		10		ns

### 7.7 Switching Characteristics: Serial Interface

specifications apply from  $T_A = -40^{\circ}\text{C}$  to  $+85^{\circ}\text{C}$  (unless otherwise noted). Load on  $D_{OUT} = 20\text{ pF} \parallel 100\text{ k}\Omega$ .

PARAMETER		2.7 V ≤ DVDD ≤ 3.6 V		1.65 V ≤ DVDD ≤ 2 V		UNIT
		MIN	MAX	MIN	MAX	
$t_{DOHD}$	SCLK falling edge to invalid DOUT: hold time	10		10		ns
$t_{DOPD}$	SCLK rising edge to DOUT valid: setup time		17		32	ns
$t_{CSDOD}$	$\overline{CS}$ low to DOUT driven	10		20		ns
$t_{CSDOZ}$	$\overline{CS}$ high to DOUT Hi-Z		10		20	ns

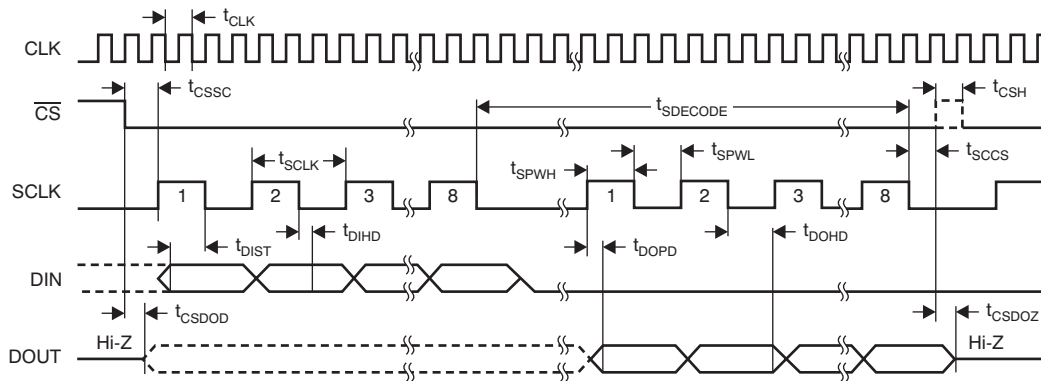

NOTE: SPI settings are CPOL = 0 and CPHA = 1.

Figure 1. Serial Interface Timing

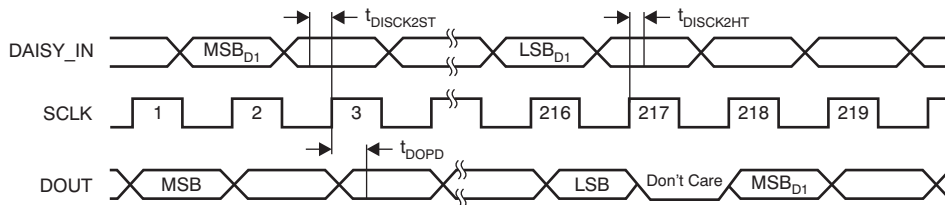

NOTE: Daisy-chain timing shown for eight-channel ADS1298 and ADS1298R.

Figure 2. Daisy-Chain Interface Timing

## 7.8 Typical Characteristics

at  $T_A = 25^\circ\text{C}$ ,  $AVDD = 3\text{ V}$ ,  $AVSS = 0\text{ V}$ ,  $DVDD = 1.8\text{ V}$ , internal  $VREFP = 2.4\text{ V}$ ,  $VREFN = AVSS$ , external clock = 2.048 MHz, data rate = 500 SPS, high-resolution mode, and gain = 6 (unless otherwise noted)

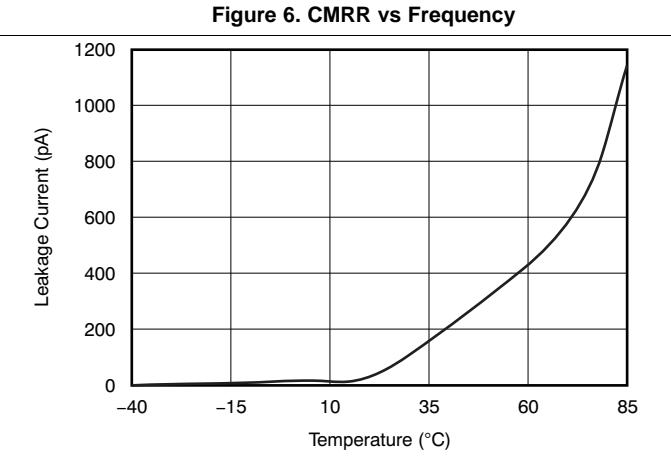
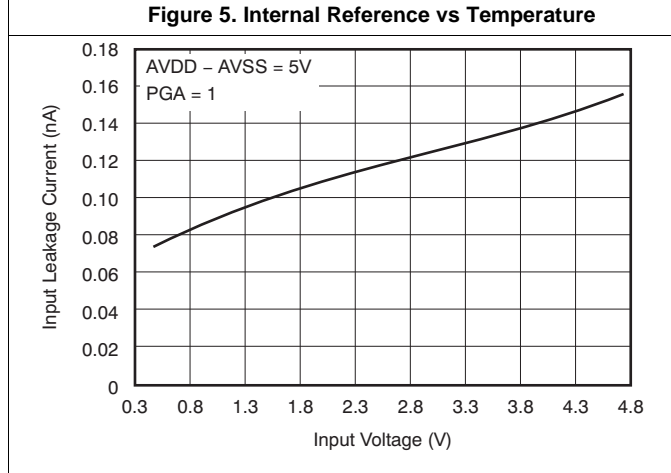
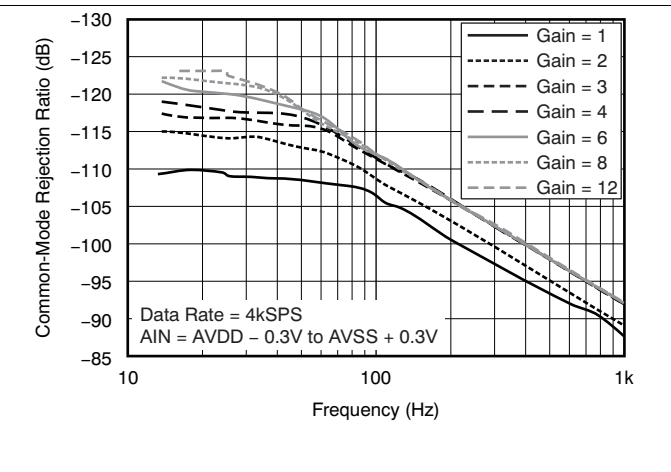
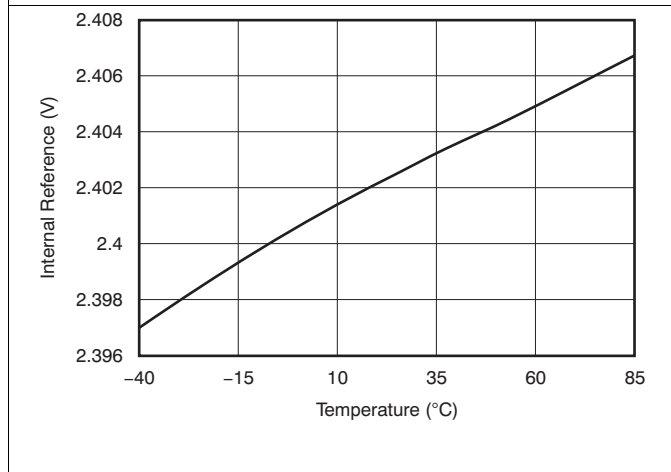
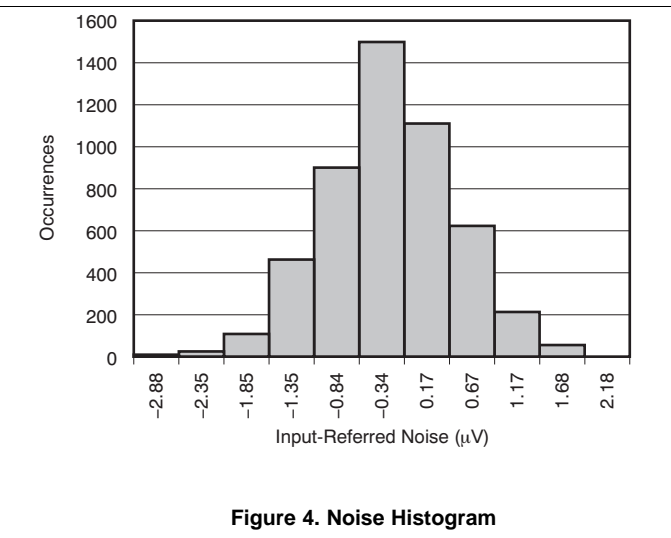
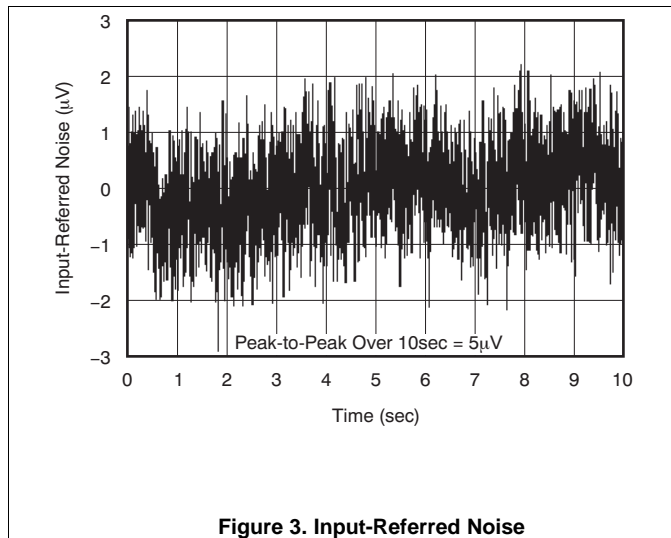

Typical Characteristics (continued)

at  $T_A = 25^\circ\text{C}$ ,  $AVDD = 3\text{ V}$ ,  $AVSS = 0\text{ V}$ ,  $DVDD = 1.8\text{ V}$ , internal  $VREFP = 2.4\text{ V}$ ,  $VREFN = AVSS$ , external clock = 2.048 MHz, data rate = 500 SPS, high-resolution mode, and gain = 6 (unless otherwise noted)

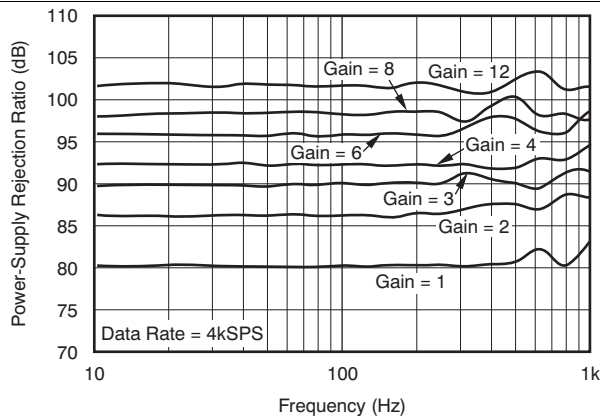

Figure 9. PSRR vs Frequency

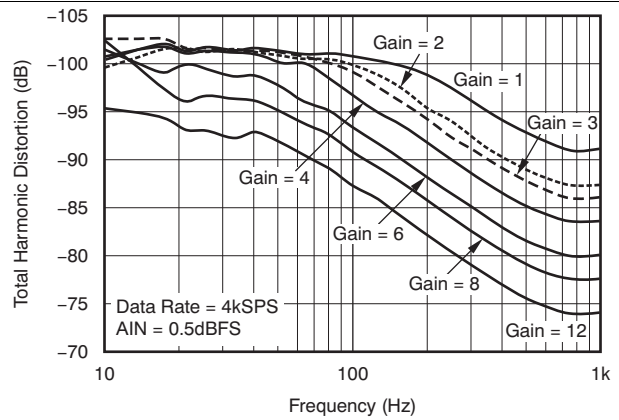

Figure 10. THD vs Frequency

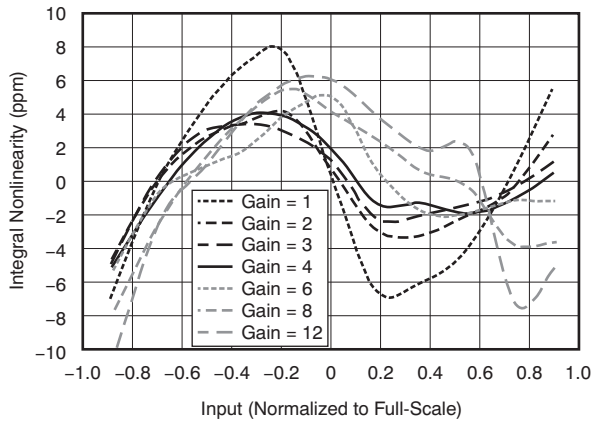

Figure 11. INL vs PGA Gain

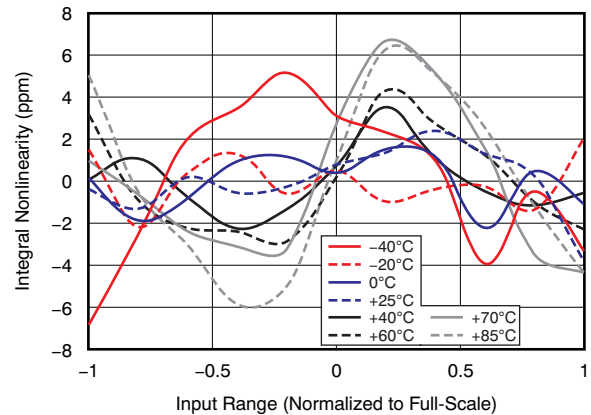

Figure 12. INL vs Temperature

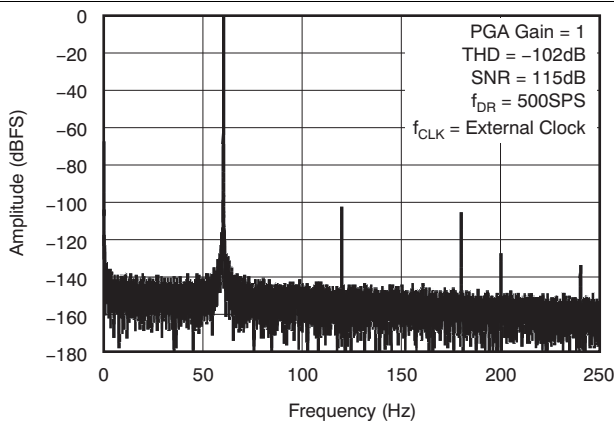

Figure 13. THD FFT Plot (60-Hz Signal)

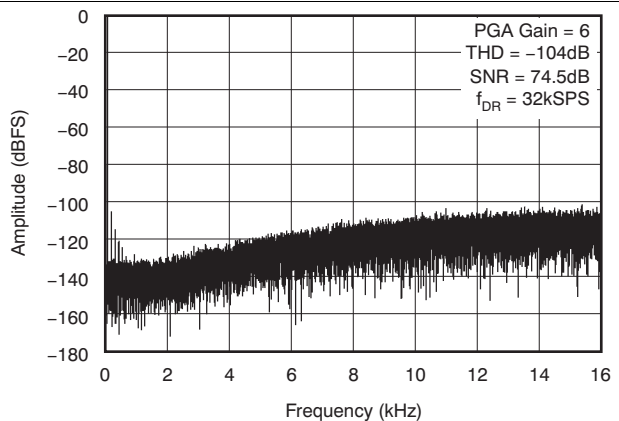

Figure 14. FFT Plot (60-Hz Signal)

### Typical Characteristics (continued)

at  $T_A = 25^\circ\text{C}$ ,  $AVDD = 3\text{ V}$ ,  $AVSS = 0\text{ V}$ ,  $DVDD = 1.8\text{ V}$ , internal  $VREFP = 2.4\text{ V}$ ,  $VREFN = AVSS$ , external clock = 2.048 MHz, data rate = 500 SPS, high-resolution mode, and gain = 6 (unless otherwise noted)

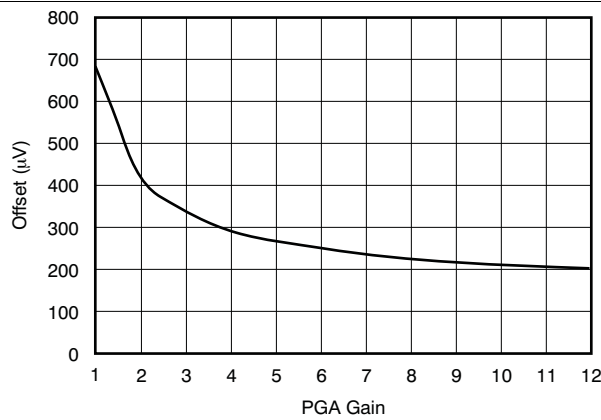

Figure 15. Offset vs PGA Gain (Absolute Value)

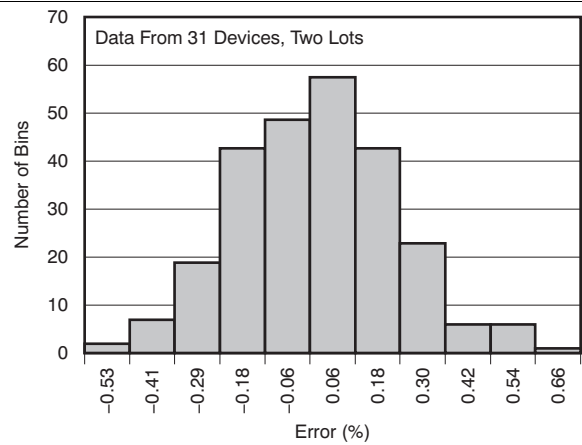

Figure 16. Test-Signal Amplitude Accuracy

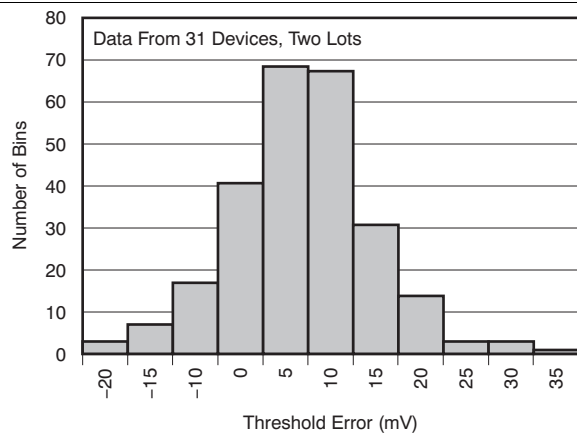

Figure 17. Lead-Off Comparator Threshold Accuracy

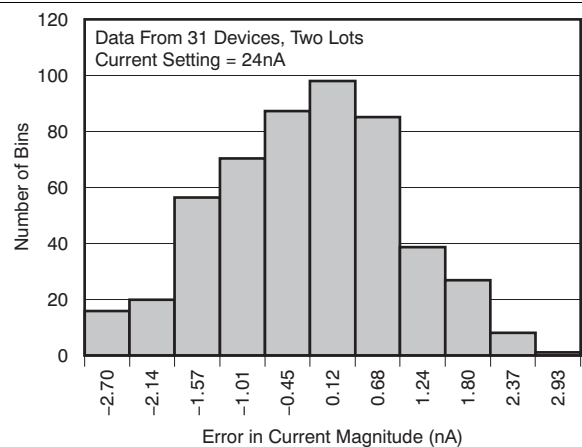

Figure 18. Lead-Off Current-Source Accuracy Distribution

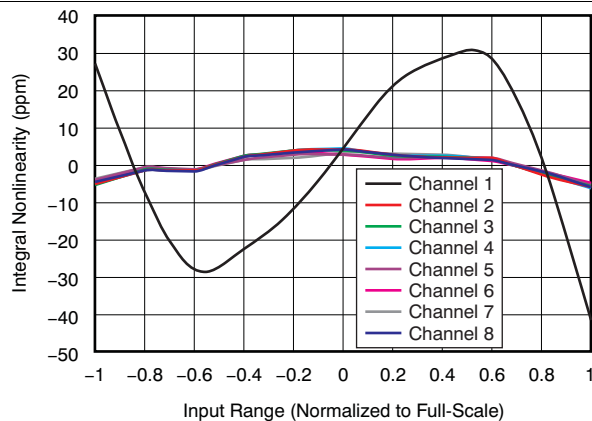

Figure 19. ADS129xR Nonlinearity

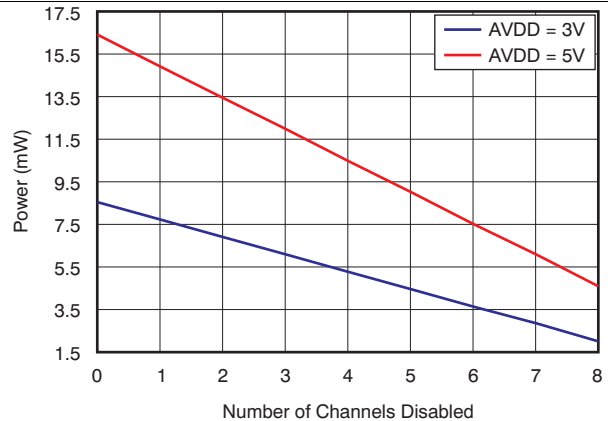
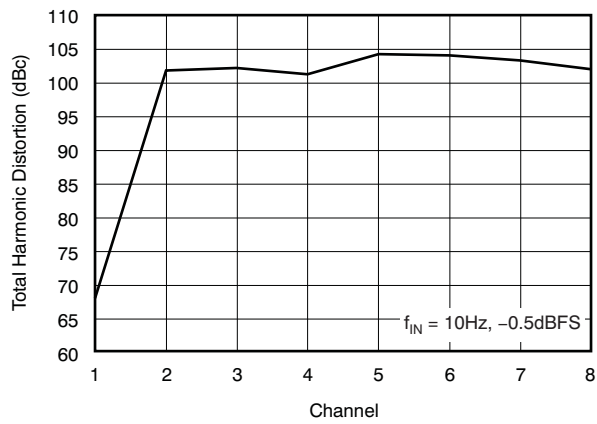

Figure 20. ADS1298 and ADS1298R Channel Power

**Typical Characteristics (continued)**

at  $T_A = 25^\circ\text{C}$ ,  $AVDD = 3\text{ V}$ ,  $AVSS = 0\text{ V}$ ,  $DVDD = 1.8\text{ V}$ , internal  $VREFP = 2.4\text{ V}$ ,  $VREFN = AVSS$ , external clock = 2.048 MHz, data rate = 500 SPS, high-resolution mode, and gain = 6 (unless otherwise noted)



**Figure 21. ADS129xR THD**

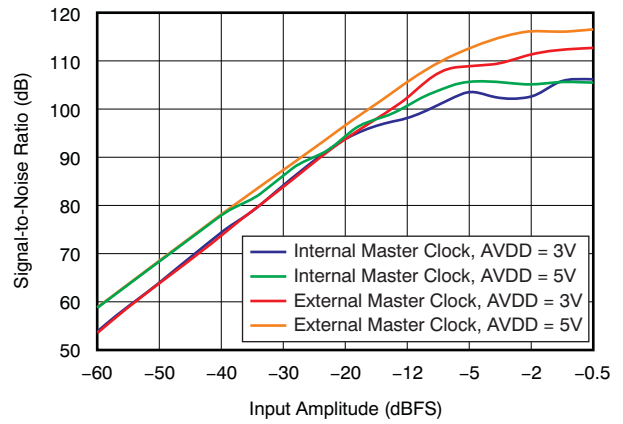

**Figure 22. SNR vs Input Amplitude (10-Hz Sine Wave)**

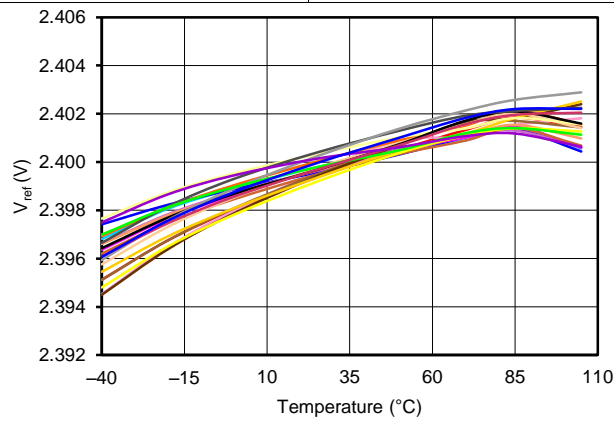

**Figure 23. Internal  $V_{REF}$  Drift vs Temperature**

## 8 Parameter Measurement Information

### 8.1 Noise Measurements

#### NOTE

The ADS129xR channel performance differs from the ADS129x in regards to respiration circuitry found on channel one. Unless otherwise noted, ADS129x refers to all specifications and functional descriptions of the ADS1294, ADS1296, ADS1298, ADS1294R, ADS1296R, and ADS1298R. ADS129xR refers to all specifications and functional descriptions of only the ADS1294R, ADS1296R, and ADS1298R.

Optimize the ADS129x noise performance by adjusting the data rate and PGA setting. Reduce the data rate to increase the averaging, and the noise drops correspondingly. Increase the PGA value to reduce the input-referred noise. This lowered noise level is particularly useful when measuring low-level biopotential signals. [Table 1](#) and [Table 2](#) summarize the noise performance of the ADS129x in high-resolution (HR) mode and low-power (LP) mode, respectively, with a 3-V analog power supply. [Table 3](#) and [Table 4](#) summarize the noise performance of the ADS129x in HR and LP modes, respectively, with a 5-V analog power supply. The data are representative of typical noise performance at  $T_A = 25^\circ\text{C}$ . The data shown are the result of averaging the readings from multiple devices and are measured with the inputs shorted together. A minimum of 1000 consecutive readings are used to calculate the RMS and peak-to-peak noise for each reading. For the two highest data rates, the noise is limited by quantization noise of the ADC and does not have a gaussian distribution. Thus, the ratio between rms noise and peak-to-peak noise is approximately 10. For the lower data rates, the ratio is approximately 6.6.

[Table 1](#) to [Table 4](#) show measurements taken with an internal reference. The data are also representative of the ADS129x noise performance when using a low-noise external reference such as the [REF5025](#).

**Table 1. Input-Referred Noise  $\mu\text{V}_{\text{RMS}}$  ( $\mu\text{V}_{\text{PP}}$ ) in High-Resolution Mode  
3-V Analog Supply and 2.4-V Reference<sup>(1)</sup>**

DR BITS OF CONFIG1 REGISTER	OUTPUT DATA RATE (SPS)	-3-dB BANDWIDTH (Hz)	PGA GAIN = 1	PGA GAIN = 2	PGA GAIN = 3	PGA GAIN = 4	PGA GAIN = 6	PGA GAIN = 8	PGA GAIN = 12
000	32000	8398	335 (3553)	168 (1701)	112 (1100)	85 (823)	58 (529)	42.5 (378)	28.6 (248)
001	16000	4193	56 (613)	28 (295)	18.8 (188)	14.3 (143)	9.7 (94)	7.4 (69)	5.2 (44.3)
010	8000	2096	12.4 (111)	6.5 (54)	4.5 (37.9)	3.5 (29.7)	2.6 (21.7)	2.2 (17.8)	1.8 (13.8)
011	4000	1048	6.1 (44.8)	3.2 (23.3)	2.4 (17.1)	1.9 (14)	1.5 (11.1)	1.3 (9.7)	1.2 (8.5)
100	2000	524	4.1 (27.8)	2.2 (15.4)	1.6 (11)	1.3 (9.1)	1.1 (7.3)	1 (6.5)	0.9 (6)
101	1000	262	2.9 (19)	1.6 (10.1)	1.2 (7.5)	1 (6.2)	0.8 (5)	0.7 (4.6)	0.6 (4.1)
110	500	131	2.1 (12.5)	1.1 (6.8)	0.9 (5.1)	0.7 (4.3)	0.6 (3.5)	0.5 (3.1)	0.5 (2.9)

(1) At least 1000 consecutive readings used to calculate the RMS and peak-to-peak noise values in this table.

**Table 2. Input-Referred Noise  $\mu\text{V}_{\text{RMS}}$  ( $\mu\text{V}_{\text{PP}}$ ) in Low-Power Mode  
3-V Analog Supply and 2.4-V Reference<sup>(1)</sup>**

DR BITS OF CONFIG1 REGISTER	OUTPUT DATA RATE (SPS)	-3-dB BANDWIDTH (Hz)	PGA GAIN = 1	PGA GAIN = 2	PGA GAIN = 3	PGA GAIN = 4	PGA GAIN = 6	PGA GAIN = 8	PGA GAIN = 12
000	16000	4193	333 (3481)	166 (1836)	111 (1168)	84 (834)	56 (576)	42 (450)	28 (284)
001	8000	2096	56 (554)	28 (272)	19 (177)	14.3 (133)	9.7 (85)	7.4 (64)	5 (42.4)
010	4000	1048	12.5 (99)	6.5 (51)	4.5 (35)	3.4 (25.9)	2.4 (18.8)	2 (14.5)	1.5 (11.3)
011	2000	524	6.1 (41.8)	3.2 (22.2)	2.3 (15.9)	1.8 (12.1)	1.4 (9.3)	1.2 (7.8)	1 (6.7)
100	1000	262	4.1 (26.3)	2.2 (14.6)	1.6 (9.9)	1.3 (8.1)	1 (6.2)	0.8 (5.4)	0.7 (4.7)
101	500	131	3 (17.9)	1.6 (9.8)	1.1 (6.8)	0.9 (5.7)	0.7 (4.2)	0.6 (3.6)	0.5 (3.4)
110	250	65	2.1 (11.9)	1.1 (6.3)	0.8 (4.6)	0.7 (4)	0.5 (3)	0.5 (2.6)	0.4 (2.4)

(1) At least 1000 consecutive readings used to calculate the RMS and peak-to-peak noise values in this table.

**Table 3. Input-Referred Noise  $\mu V_{RMS}$  ( $\mu V_{PP}$ ) in High-Resolution Mode  
5-V Analog Supply and 4-V Reference<sup>(1)</sup>**

DR BITS OF CONFIG1 REGISTER	OUTPUT DATA RATE (SPS)	-3-dB BANDWIDTH (Hz)	PGA GAIN = 1	PGA GAIN = 2	PGA GAIN = 3	PGA GAIN = 4	PGA GAIN = 6	PGA GAIN = 8	PGA GAIN = 12
000	32000	8398	521 (5388)	260 (2900)	173 (1946)	130 (1403)	87 (917)	65 (692)	44 (483)
001	16000	4193	86 (1252)	43 (633)	29 (402)	22 (298)	15 (206)	11 (141)	7 (91)
010	8000	2096	17 (207)	9 (112)	6 (71)	4 (57)	3 (36)	3 (29)	2 (18)
011	4000	1048	6.4 (48.2)	3.4 (25.9)	2.4 (17.7)	1.9 (15.4)	1.5 (11.2)	1.3 (9.6)	1.1 (8.2)
100	2000	524	4.2 (29.9)	2.3 (15.9)	1.6 (11.1)	1.3 (9.3)	1 (7.5)	0.9 (6.6)	0.8 (5.8)
101	1000	262	2.9 (18.8)	1.6 (10.4)	1.1 (7.8)	0.9 (6.1)	0.7 (4.9)	0.6 (4.7)	0.6 (3.9)
110	500	131	2 (12.8)	1.1 (7.2)	0.8 (5.2)	0.7 (4)	0.5 (3.3)	0.5 (3.3)	0.4 (2.7)

(1) At least 1000 consecutive readings used to calculate the RMS and peak-to-peak noise values in this table.

**Table 4. Input-Referred Noise  $\mu V_{RMS}$  ( $\mu V_{PP}$ ) in Low-Power Mode  
5-V Analog Supply and 4-V Reference<sup>(1)</sup>**

DR BITS OF CONFIG1 REGISTER	OUTPUT DATA RATE (SPS)	-3-dB BANDWIDTH (Hz)	PGA GAIN = 1	PGA GAIN = 2	PGA GAIN = 3	PGA GAIN = 4	PGA GAIN = 6	PGA GAIN = 8	PGA GAIN = 12
000	16000	4193	526 (5985)	263 (2953)	175 (1918)	132 (1410)	88 (896)	66 (681)	44 (458)
001	8000	2096	88 (1201)	44 (619)	29 (411)	22 (280)	15 (191)	11 (139)	7 (83)
010	4000	1048	17 (208)	9 (103)	6 (62)	4 (52)	3 (37)	2 (25)	2 (16)
011	2000	524	6 (41.1)	3.3 (23.3)	2.2 (15.5)	1.8 (12.3)	1.3 (9.8)	1.1 (7.8)	0.9 (6.5)
100	1000	262	4.1 (27.1)	2.3 (14.8)	1.5 (10.1)	1.2 (8.1)	0.9 (6)	0.8 (5.4)	0.7 (4.4)
101	500	131	2.9 (17.4)	1.6 (9.6)	1.1 (6.6)	0.9 (5.9)	0.7 (4.3)	0.6 (3.4)	0.5 (3.2)
110	250	65	2.1 (11.9)	1.1 (6.6)	0.8 (4.6)	0.6 (3.7)	0.5 (3)	0.4 (2.5)	0.4 (2.2)

(1) At least 1000 consecutive readings used to calculate the RMS and peak-to-peak noise values in this table.

## 9 Detailed Description

### 9.1 Overview

---

#### NOTE

The ADS129xR channel performance differs from the ADS129x in regards to respiration circuitry found on channel one. Unless otherwise noted, ADS129x refers to all specifications and functional descriptions of the ADS1294, ADS1296, ADS1298, ADS1294R, ADS1296R, and ADS1298R. ADS129xR refers to all specifications and functional descriptions of only the ADS1294R, ADS1296R, and ADS1298R.

---

The ADS129x are low-power, multichannel, simultaneously-sampling, 24-bit delta-sigma ( $\Delta\Sigma$ ) analog-to-digital converters (ADCs) with integrated programmable gain amplifiers (PGAs). These devices incorporate various ECG-specific functions that make them well-suited for scalable electrocardiogram (ECG), electroencephalography (EEG), and electromyography (EMG) applications. These devices are also used in high-performance, multichannel data acquisition systems by powering down the ECG-specific circuitry.

The ADS129x have a highly-programmable multiplexer (mux) that allows for temperature, supply, input short, and RLD measurements. Additionally, the mux allows any of the input electrodes to be programmed as the patient reference drive. The PGA gain is chosen from one of seven settings: 1, 2, 3, 4, 6, 8, or 12. The ADCs in the device offer data rates from 250 SPS to 32 kSPS. Communicate with the device by using an SPI-compatible interface. The device provides four GPIO pins for general use. Synchronize multiple devices by using the START pin.

Program the internal reference to either 2.4 V or 4 V. The internal oscillator generates a 2.048-MHz clock. The versatile right-leg drive (RLD) block allows for choosing the average of any combination of electrodes to generate the patient drive signal. Lead-off detection is accomplished either by using a pullup or pulldown resistor, or a current source or sink. An internal ac lead-off detection feature is also available. These devices support both hardware pace detection and software pace detection. Use the Wilson central terminal (WCT) block to generate the WCT point of the standard 12-lead ECG.

Additionally, the ADS129xR provide options for an internal respiration modulator and a demodulator circuit in the signal path of channel 1.

## 9.2 Functional Block Diagram

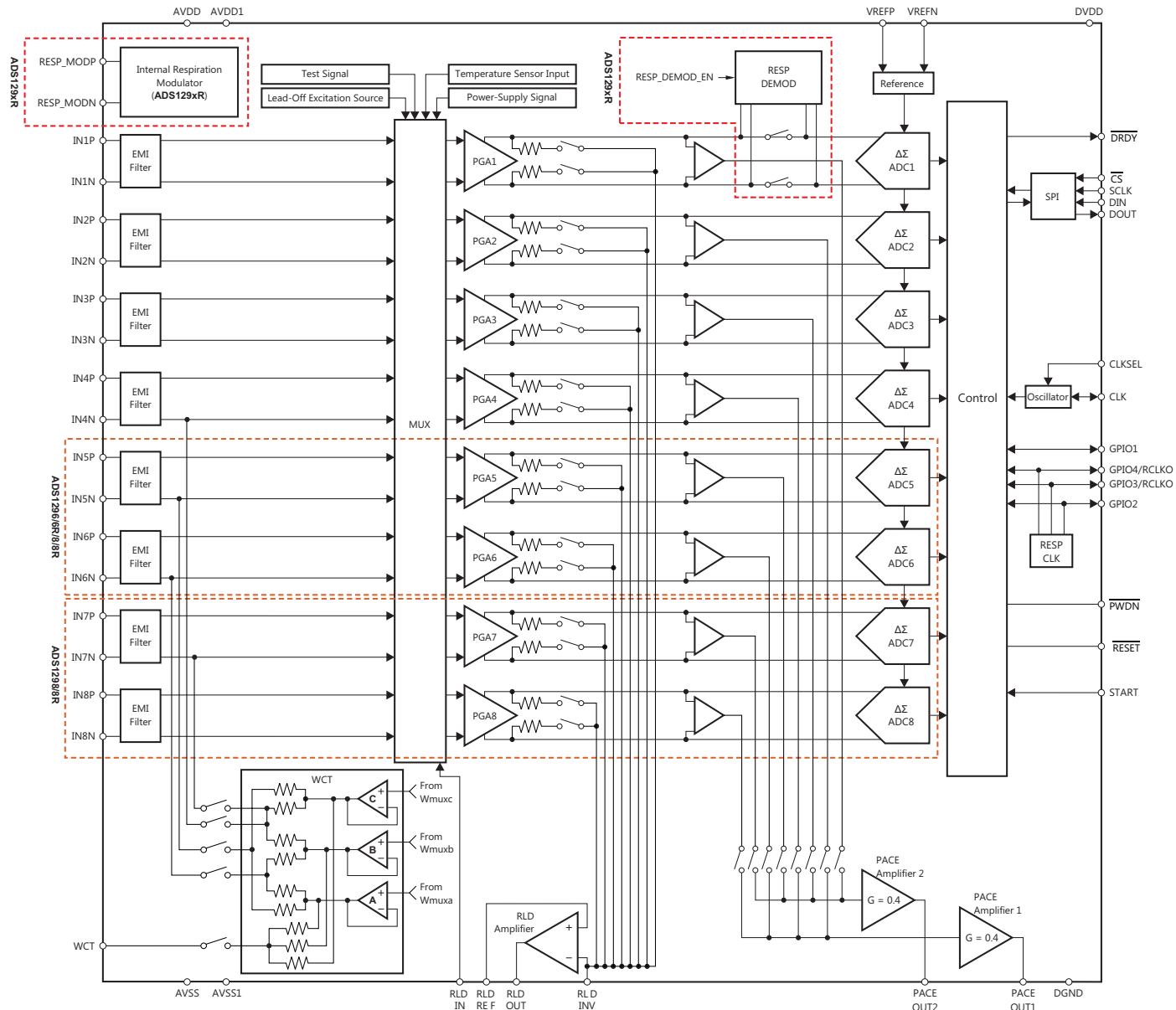

## 9.3 Feature Description

This section discusses the details of the ADS129x internal functional elements. The analog blocks are reviewed first, followed by the digital interface. Blocks implementing ECG-specific functions are covered at the end.

Throughout this document,  $f_{CLK}$  denotes the frequency of the signal at the CLK pin,  $t_{CLK}$  denotes the period of the signal at the CLK pin,  $f_{DR}$  denotes the output data rate,  $t_{DR}$  denotes the time period of the output data, and  $f_{MOD}$  denotes the modulator input sampling frequency.

### 9.3.1 Analog Functionality

#### 9.3.1.1 EMI Filter

An RC filter at the input acts as an EMI filter on all channels. The  $-3$ -dB filter bandwidth is approximately 3 MHz.

#### 9.3.1.2 Analog Input Structure

The analog input of the ADS129x is shown in [Figure 24](#).

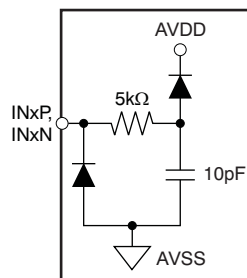
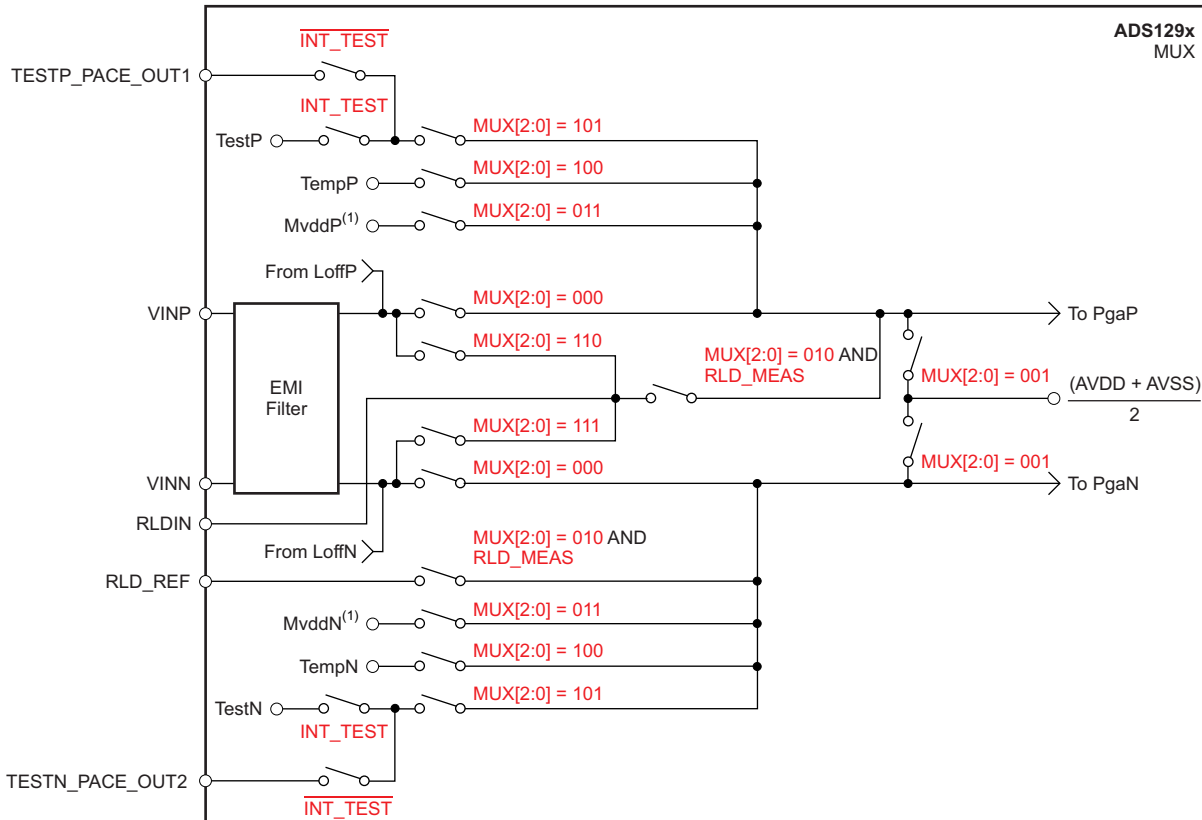

**Figure 24. Analog Input Protection Circuit**

## Feature Description (continued)

### 9.3.1.3 Input Multiplexer

The ADS129x input multiplexers are very flexible and provide many configurable signal-switching options. Figure 25 shows the multiplexer on a single channel of the device. The device has eight blocks, one for each channel. TEST\_PACE\_OUT1, TEST\_PACE\_OUT2, and RLD\_IN are common to all eight blocks. VINP and VINN are separate for each of the eight blocks. This flexibility allows for significant device and subsystem diagnostics, calibration, and configuration. Select the switch settings for each channel by writing 1 to the appropriate values to the CHnSET[2:0] register (see the CHnSET register for details) and the RLD\_MEAS bit in the CONFIG3 register (see the CONFIG3 register for details). More details of the ECG-specific features of the multiplexer are presented in the *Input Multiplexer (Rerouting The Right Leg Drive Signal)* subsection of the *ECG-Specific Functions* section.



(1) MVDD monitor voltage supply depends on channel number; see the *Supply Measurements (MVDDP, MVDDN)* section.

Figure 25. Input Multiplexer Block for One Channel

## Feature Description (continued)

### 9.3.1.3.1 Device Noise Measurements

Setting CH $n$ SET[2:0] = 001 sets the common-mode voltage of (AVDD – AVSS) / 2 to both inputs of the channel. Use this setting to test the inherent noise of the device.

### 9.3.1.3.2 Test Signals (TestP and TestN)

Setting CH $n$ SET[2:0] = 101 provides internally-generated test signals for use in subsystem verification at power up. This functionality allows the entire signal chain to be tested. Although the test signals are similar to the CAL signals described in the IEC60601-2-51 specification, this feature is not intended for use in compliance testing.

Use register settings to control the test signals (see the [CONFIG2: Configuration Register 2 \(address = 02h\) \(reset = 40h\)](#) section for details). The TEST\_AMP bit controls the signal amplitude, and the TEST\_FREQ bits control switching at the required frequency.

The test signals are multiplexed and transmitted out of the device at the TESTP\_PACE\_OUT1 and TESTN\_PACE\_OUT2 pins. A bit register (CONFIG2.INT\_TEST = 0) deactivates the internal test signals so that the test signal can be driven externally. This feature allows the calibration of multiple devices with the same signal. The test signal feature cannot be used in conjunction with the external hardware pace feature (see the [External Hardware Approach](#) section for details).

### 9.3.1.3.3 Auxiliary Differential Input (TESTP\_PACE\_OUT1, TESTN\_PACE\_OUT2)

When hardware pace detection is not used, the TESTP\_PACE\_OUT1 and TESTN\_PACE\_OUT2 signals can be used as a multiplexed differential input channel. These inputs can be multiplexed to any of the eight channels. The performance of the differential input signal fed through these pins is identical to the normal channel performance.

### 9.3.1.3.4 Temperature Sensor (TempP, TempN)

The ADS129x contain an on-chip temperature sensor. This sensor uses two internal diodes with one diode having a current density 16x that of the other, as shown in [Figure 26](#). The difference in current densities of the diodes yields a difference in voltage that is proportional to absolute temperature.

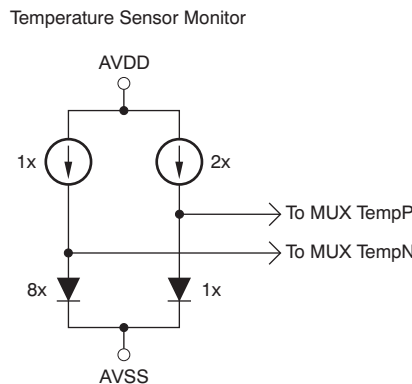

**Figure 26. Measurement of the Temperature Sensor in the Input**

As a result of the low thermal resistance of the package to the printed circuit board (PCB), the internal sensor tracks the PCB temperature closely. Self-heating of the ADS129x causes a higher reading than the temperature of the surrounding PCB.

The scale factor of [Equation 1](#) converts the temperature reading to °C. Before using this equation, scale the the temperature reading code to  $\mu\text{V}$ .

$$\text{Temperature (}^\circ\text{C)} = \left[ \frac{\text{Temperature Reading (}\mu\text{V)} - 145,300 \mu\text{V}}{490 \mu\text{V}/^\circ\text{C}} \right] + 25^\circ\text{C} \quad (1)$$

## Feature Description (continued)

### 9.3.1.3.5 Supply Measurements (MVDDP, MVDDN)

Setting CHnSET[2:0] = 011 sets the channel inputs to different supply voltages of the device.

For channels 1, 2, 5, 6, 7, and 8,  $(MVDDP - MVDDN) = [0.5 \times (AVDD - AVSS)]$

For channels 3 and 4,  $(MVDDP - MVDDN) = DVDD / 4$ .

To avoid saturating the PGA while measuring power supplies, set the gain to 1.

For example, if AVDD = 2.5 V and AVSS = -2.5 V, then the measurement result is 2.5 V.

### 9.3.1.3.6 Lead-Off Excitation Signals (LoffP, LoffN)

The lead-off excitation signals are fed into the multiplexer before the switches. The comparators that detect the lead-off condition are also connected to the multiplexer block before the switches. For a detailed description of the lead-off block, refer to the [Lead-Off Detection](#) section.

### 9.3.1.3.7 Auxiliary Single-Ended Input

The RLD\_IN pin is primarily used for routing the right leg drive (RLD) signal to any of the electrodes in case the RLD electrode falls off. However, the RLD\_IN pin can be used as a multiple single-ended input channel. The signal at the RLD\_IN pin can be measured with respect to the voltage at the RLD\_REF pin using any of the eight channels. This measurement is done by setting the channel multiplexer setting to 010, and the RLD\_MEAS bit of the CONFIG3 register to 1.

## Feature Description (continued)

### 9.3.1.4 Analog Input

The analog input to the ADS129x is fully differential. Assuming  $PGA = 1$ , the differential input ( $INP - INN$ ) can span between  $-V_{REF}$  to  $V_{REF}$ . The absolute range for  $INP$  and  $INN$  must be between  $AVSS - 0.3 V$  and  $AVDD + 0.3 V$ . See [Table 13](#) for an explanation of the correlation between the analog input and the digital codes. As shown in [Figure 27](#) and [Figure 28](#), there are two general methods of driving the analog input of the ADS129x: single-ended or differential.  $INP$  and  $INN$  are  $180^\circ$  out-of-phase in the differential input method. When the input is single-ended, the  $INN$  input is held at the common-mode voltage (CM), preferably at midsupply. The  $INP$  input swings around the same common-mode voltage and the peak-to-peak amplitude swings from  $CM - V_{REF}$  to  $CM + V_{REF}$ . When the input is differential, the common-mode is given by  $(INP + INN) / 2$ . Both the  $INP$  and  $INN$  inputs swing from  $CM + \frac{1}{2} V_{REF}$  to  $CM - \frac{1}{2} V_{REF}$ . For optimal performance, use the ADS129x devices in a differential configuration.

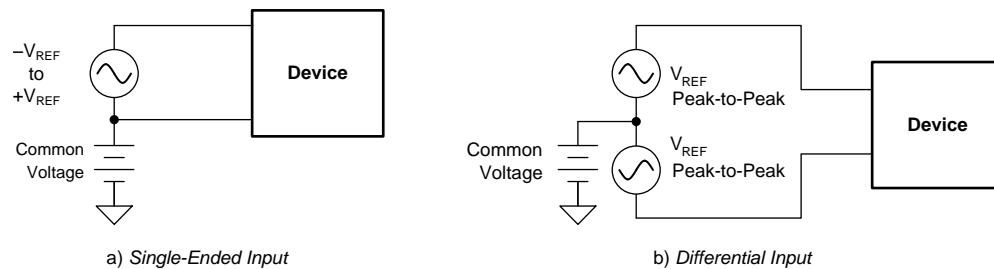

**Figure 27. Methods of Driving the ADS129x: Single-Ended or Differential**

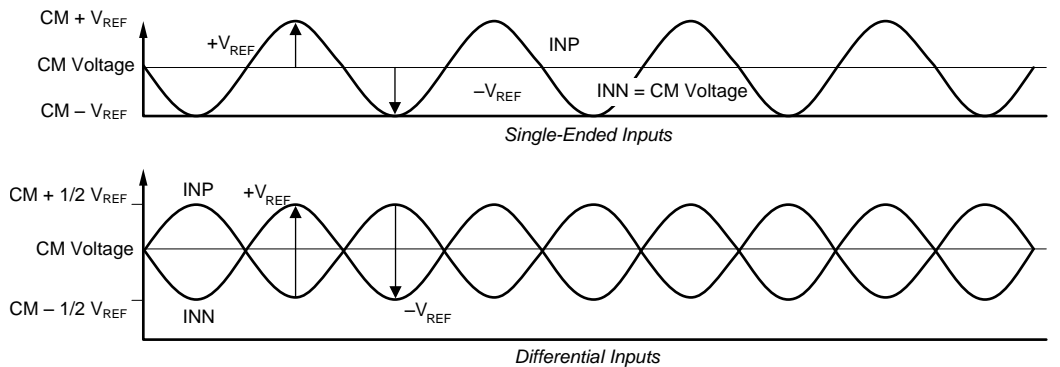

$$\text{Common-Mode Voltage (Differential Mode)} = \frac{(INP) + (INN)}{2}, \text{ Common-Mode Voltage (Single-Ended Mode)} = INN$$

$$\text{Input Range (Differential Mode)} = (AINP - AINN) = 2 V_{REF}$$

**Figure 28. Using the ADS129x in Single-Ended and Differential Input Modes**

### 9.3.1.5 PGA Settings and Input Range

The PGA is a differential input and differential output amplifier, as shown in Figure 29. The PGA has seven gain settings (1, 2, 3, 4, 6, 8, and 12) that are set by writing to the CHnSET register (see the *CHnSET: Individual Channel Settings (n = 1 to 8) (address = 05h to 0Ch) (reset = 00h)* section). The ADS129x have CMOS inputs, and therefore have negligible current noise. Table 5 shows the typical values of bandwidths for various gain settings. Table 5 shows the small-signal bandwidth.

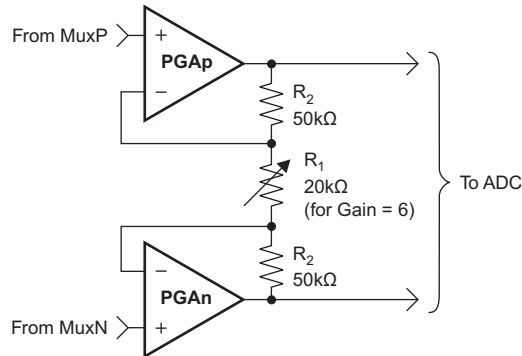

Figure 29. PGA Implementation

Table 5. PGA Gain versus Small-Signal Bandwidth

GAIN	NOMINAL BANDWIDTH AT ROOM TEMPERATURE (kHz)
1	237
2	146
3	127
4	96
6	64
8	48
12	32

The resistor string of the PGA that implements the gain has 120 kΩ of resistance for a gain of 6. This resistance provides a current path across the outputs of the PGA in the presence of a differential input signal. This current is in addition to the quiescent current specified for the device in the presence of a differential signal at the input.

### 9.3.1.5.1 Input Common-Mode Range

The usable input common-mode range of the front end depends on various parameters, including the maximum differential input signal, supply voltage, PGA gain, and more. This range is described in [Equation 2](#):

$$AVDD - 0.2 \text{ V} - \left( \frac{\text{Gain} \times V_{\text{MAX\_DIFF}}}{2} \right) > \text{CM} > AVSS + 0.2 \text{ V} + \left( \frac{\text{Gain} \times V_{\text{MAX\_DIFF}}}{2} \right)$$

where

- $V_{\text{MAX\_DIFF}}$  = maximum differential signal at the input of the PGA
- CM = common-mode range

For example, if  $V_{\text{DD}} = 3 \text{ V}$ , gain = 6, and  $V_{\text{MAX\_DIFF}} = 350 \text{ mV}$ , then  $1.25 \text{ V} < \text{CM} < 1.75 \text{ V}$ .

### 9.3.1.5.2 Input Differential Dynamic Range

The differential (INP – INN) signal range depends on the analog supply and reference used in the system. This range is shown in [Equation 3](#).

$$\text{Full-Scale Range} = \frac{\pm V_{\text{REF}}}{\text{Gain}} = \frac{2V_{\text{REF}}}{\text{Gain}} \quad (3)$$

The 3-V supply, with a reference of 2.4 V and a gain of 6 for ECGs, is optimized for power with a differential input signal of approximately 300 mV. For higher dynamic range, use a 5-V supply with a reference of 4 V (set by the VREF\_4V bit of the CONFIG3 register) to increase the differential dynamic range.

### 9.3.1.5.3 ADC Delta-Sigma Modulator

Each channel of the ADS129x has a 24-bit, delta-sigma ADC. This converter uses a second-order modulator optimized for low-power applications. The modulator samples the input signal at the rate of  $f_{\text{MOD}} = f_{\text{CLK}} / 4$  for high-resolution (HR) mode and  $f_{\text{MOD}} = f_{\text{CLK}} / 8$  for low-power (LP) mode. As in the case of any delta-sigma modulator, the noise of the ADS129x is shaped until  $f_{\text{MOD}} / 2$ , as shown in [Figure 30](#). Use the on-chip digital decimation filters, explained in the [Digital Decimation Filter](#) section, to filter out the noise at higher frequencies. These on-chip decimation filters also provide antialias filtering. This feature of the delta-sigma converters drastically reduces the complexity of the analog antialiasing filters that are typically needed with Nyquist ADCs.

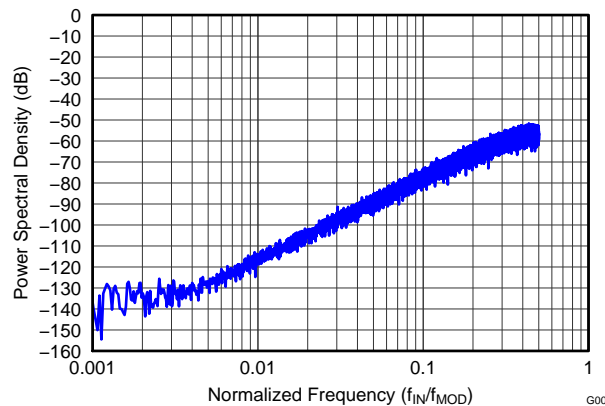

**Figure 30. Modulator Noise Spectrum up to  $0.5 \times f_{\text{MOD}}$**

### 9.3.1.6 Reference

Figure 31 shows a simplified block diagram of the ADS129x internal reference. The reference voltage is generated with respect to AVSS. When using the internal voltage reference, connect VREFN to AVSS.

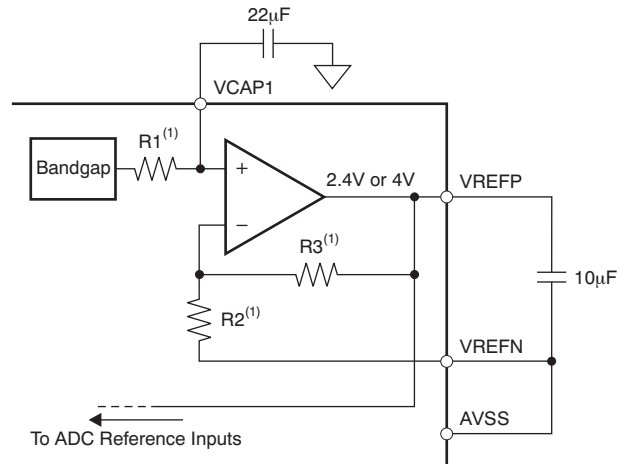

- (1) For  $V_{REF} = 2.4\text{ V}$ :  $R1 = 12.5\text{ k}\Omega$ ,  $R2 = 25\text{ k}\Omega$ , and  $R3 = 25\text{ k}\Omega$ . For  $V_{REF} = 4\text{ V}$ :  $R1 = 10.5\text{ k}\Omega$ ,  $R2 = 15\text{ k}\Omega$ , and  $R3 = 35\text{ k}\Omega$ .

**Figure 31. Internal Reference**

The external band-limiting capacitors determine the amount of reference noise contribution. For high-end ECG systems, choose capacitor values with a bandwidth that is limited to less than 10Hz, so that the reference noise does not dominate the system noise. When using a 3-V analog supply, set the internal reference to 2.4 V. For a 5-V analog supply, set the internal reference to 4 V by setting the VREF\_4V bit in the CONFIG2 register.

Alternatively, the internal reference buffer can be powered down and VREFP can be applied externally. Figure 32 shows a typical external reference drive circuitry. Power down is controlled by the PD\_REFBUF bit in the CONFIG3 register. By default, the device wakes up in external reference mode.

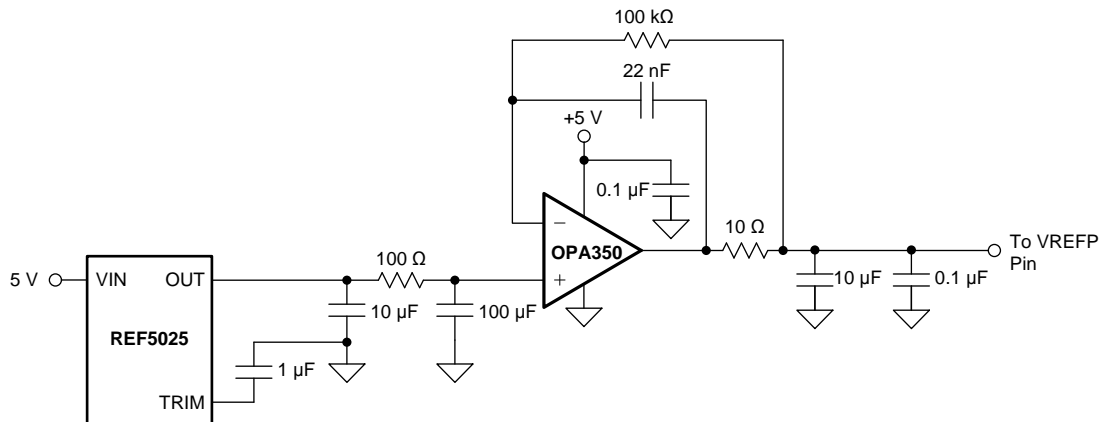
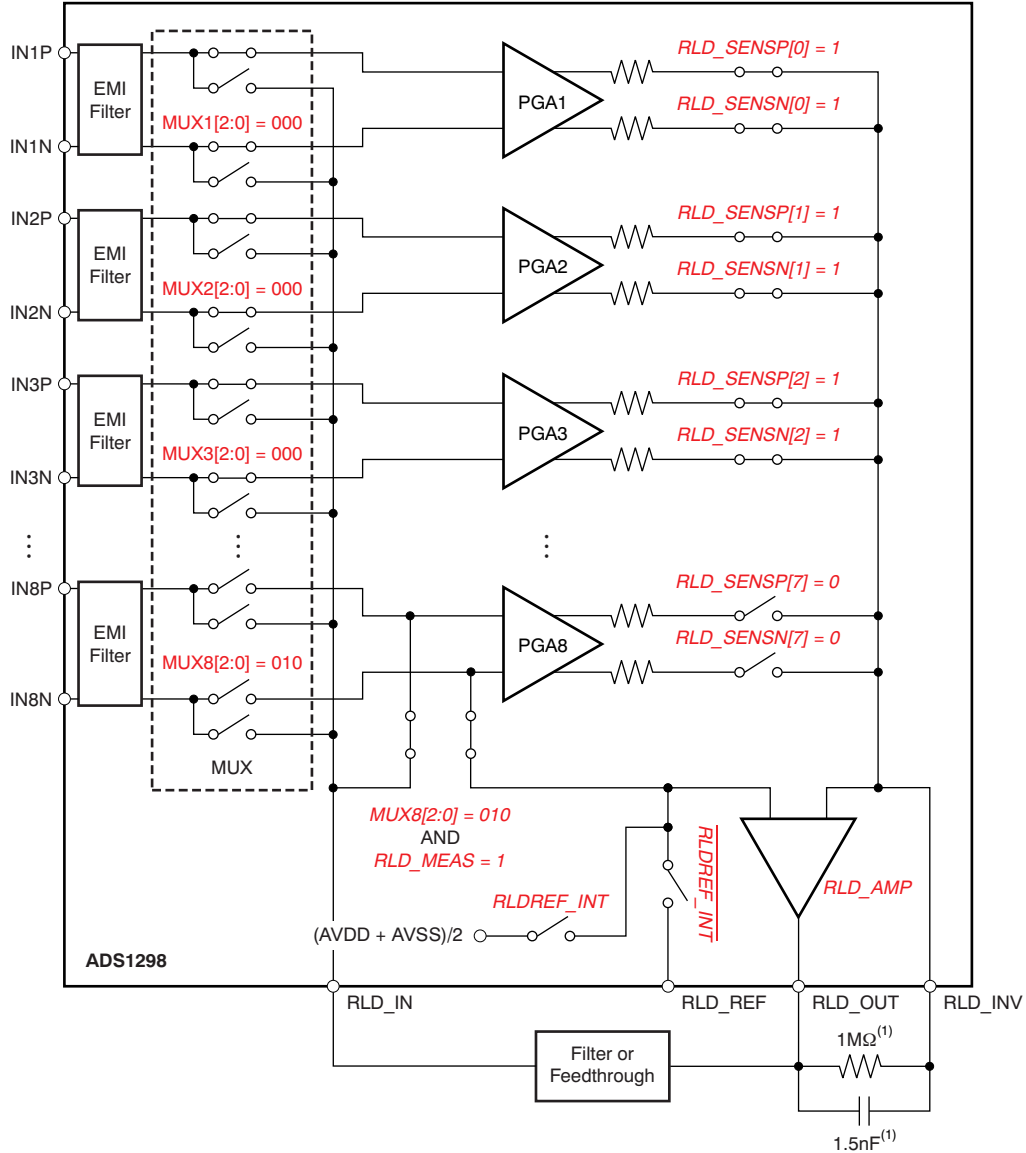

**Figure 32. External Reference Driver**



9.3.1.7.2 Input Multiplexer (Measuring The Right Leg Drive Signal)

The RLDOUT signal can also be routed to a channel (that is not used for the calculation of RLD) for measurement. Figure 34 shows the register settings to route the RLDIN signal to channel 8. The measurement is done with respect to the voltage on the RLDREF pin. If RLDREF is set to internal, it is at  $(AVDD + AVSS) / 2$ . This feature is useful for debugging purposes during product development.



(1) Typical values for example only.

Figure 34. RLDOUT Signal Configured to be Read Back by Channel 8

### 9.3.1.7.3 Wilson Central Terminal (WCT) and Chest Leads

In the standard 12-lead ECG, WCT voltage is defined as the average of right arm (RA), left arm (LA), and left leg (LL) electrodes. This voltage is used as the reference voltage for the measurement of the chest leads. The ADS129x has three integrated low-noise amplifiers that generate the WCT voltage. Figure 35 shows the block diagram of the implementation.

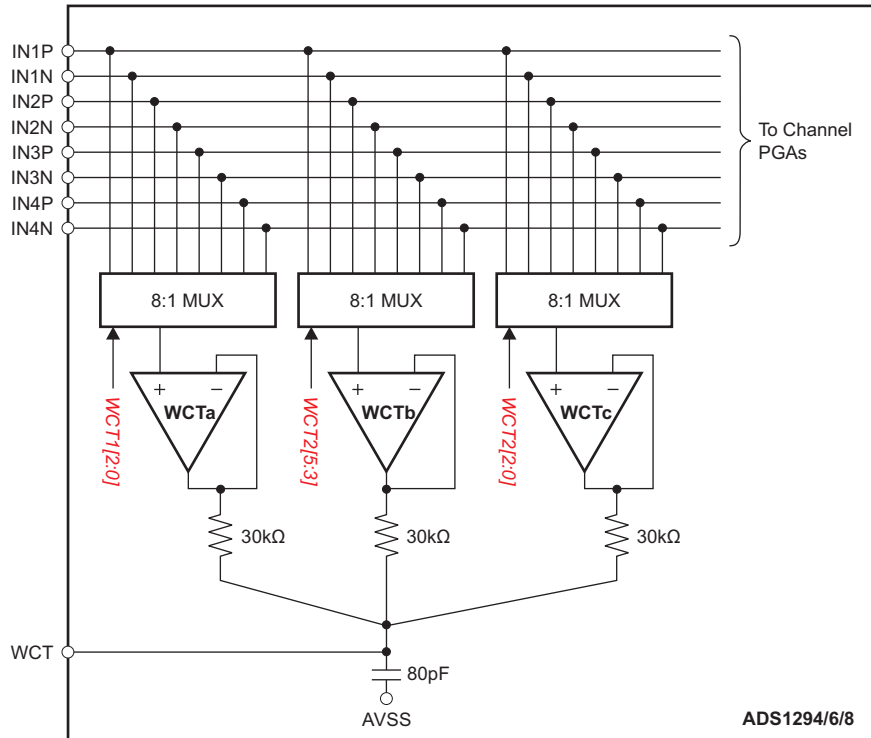

**Figure 35. WCT Voltage**

These devices provide the flexibility to route any one of the eight signals (IN1P to IN4N) to each of the amplifiers to generate the average. This flexibility allows the RA, LA, and LL electrodes to be connected to any input of the first four channels, depending on the lead configuration.

Each of the three amplifiers in the WCT circuitry can be powered down individually with register settings. By powering up two amplifiers, the average of any two electrodes is generated at the WCT pin. Powering up one amplifier provides the buffered electrode voltage at the WCT pin. The WCT amplifiers have limited drive strength, and thus, should be buffered if used to drive a low-impedance load.

Table 6 shows the typical WCT performance when using any 1, 2, or 3 of the WCT buffers.

**Table 6. Typical WCT Performance**

PARAMETER	ANY ONE (A, B, or C)	ANY TWO (A+B, A+C, or B+C)	ALL THREE (A+B+C)	UNIT
Integrated noise	540	382	312	nV <sub>RMS</sub>
Power	53	59	65	μW
–3-dB BW	30	59	89	kHz
Slew rate	BW limited	BW limited	BW limited	V/μs

As shown in Table 6, the overall noise reduces when more than one WCT amplifier is powered up. This noise reduction is a result of the fact that noise is averaged by the passive summing network at the output of the amplifiers. Powering down individual buffers gives negligible power savings because a significant portion of the circuitry is shared between the three amplifiers. The bandwidth of the WCT node is limited by the RC network. The internal summing network consists of three 30-kΩ resistors and a 80-pF capacitor. For optimal performance, add an external 100-pF capacitor. The effective bandwidth depends on the number of amplifiers that are powered up, as shown in Table 6.

Only use the WCT node to drive very high input impedances (typically greater than 500 MΩ). A typical application connects this WCT signal to the negative inputs of a ADS129x for use as a reference signal for the chest leads.

As mentioned, all three WCT amplifiers can be connected to one of eight analog input pins. The inputs of the amplifiers are chopped, and the chop frequency varies with the data rates of the ADS129x. The chop frequency for the three highest data rates scale 1:1. For example, at a 32-kSPS data rate, the chop frequency is 32 kHz in HR mode with WCT\_CHOP = 0. The chop frequency of the four lower data rates is fixed at 4 kHz. When WCT\_CHOP = 1, the chop frequency is fixed to highest data rate frequency (that is,  $f_{MOD} / 16$ ), as shown in Table 7. The chop frequency appears at the output of the WCT amplifiers as a small square wave riding on dc. The amplitude of the square wave is the offset of the amplifier and is typically 5 mV<sub>pp</sub>. As a result of out-of-band chopping, this artifact does not interfere with ECG-related measurements. As a result of the chopping function, the input current leakage on the pins with the connected WCT amplifiers increases at higher data rates and as the input common voltage swings closer to 0 V (AVSS), as described in Figure 36.

If the output of a channel connected to the WCT amplifier (for example, the V-lead channels) is connected to one of the pace amplifiers for external pace detection, the chopping artifact appears at the pace amplifier output.

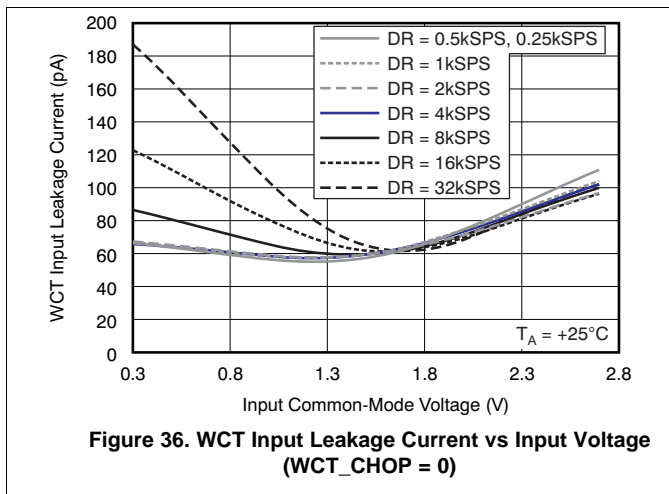

Figure 36. WCT Input Leakage Current vs Input Voltage (WCT\_CHOP = 0)

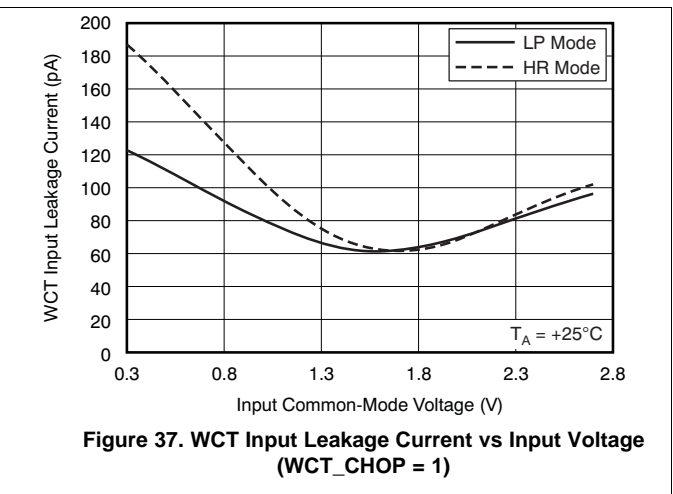

Figure 37. WCT Input Leakage Current vs Input Voltage (WCT\_CHOP = 1)

Table 7. WCT Amplifiers Chop Frequency

CONFIG1.DR[2:0] BIT	CONFIG2.WCT_CHOP = 0	CONFIG2.WCT_CHOP = 1
000	$f_{MOD}/16$	$f_{MOD}/16$
001	$f_{MOD} / 32$	$f_{MOD} / 16$
010	$f_{MOD} / 64$	$f_{MOD} / 16$
011	$f_{MOD} / 128$	$f_{MOD} / 16$
100	$f_{MOD} / 128$	$f_{MOD} / 16$
101	$f_{MOD} / 128$	$f_{MOD} / 16$
110	$f_{MOD} / 128$	$f_{MOD} / 16$

### 9.3.1.7.3.1 Augmented Leads

In a typical implementation of the 12-lead ECG with eight channels, the augmented leads are calculated digitally. In certain applications, it may be required that all leads are derived in analog rather than digital. The ADS1298 and ADS1298R provide the option to generate the augmented leads by routing appropriate averages to channels 5, 6, and 7. The same three amplifiers that are used to generate the WCT signal are also used to generate the Goldberger central terminal (GCT) signals. [Figure 38](#) shows an example of generating the augmented leads in analog domain. In this implementation, more than eight channels are used to generate the standard 12 leads. This feature is not available in the ADS1294, ADS1294R, ADS1296 and ADS1296R.

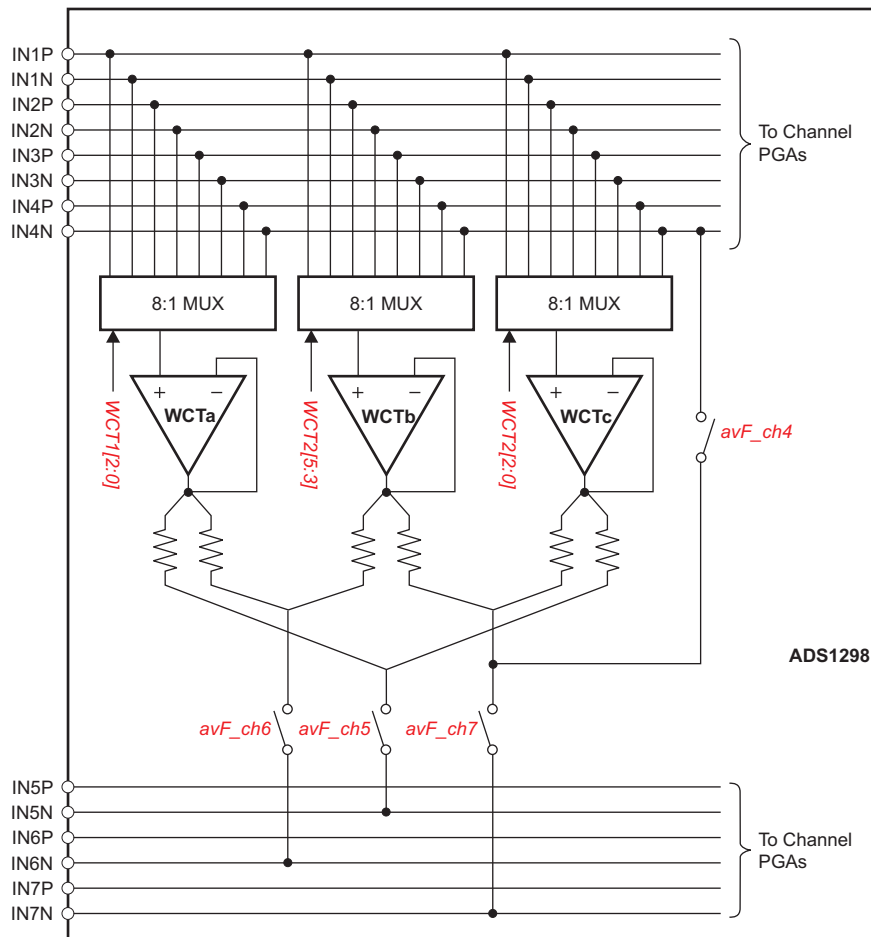

**Figure 38. Analog Domain Augmented Leads**

### 9.3.1.7.3.2 Right Leg Drive with the WCT Point

In certain applications, the out-of-phase version of the WCT is used as the RLD reference. The ADS1298 provides the option to have a buffered version of the WCT terminal at the RLD\_OUT pin. This signal can be inverted in phase using an external amplifier and then used as the right leg drive. Refer to the [Right Leg Drive \(RLD DC Bias Circuit\)](#) section for more details.

9.3.1.7.4 Lead-Off Detection

Patient electrode impedances decay over time; therefore, these electrode connections must be continuously monitored to verify that a suitable connection is present. The ADS129x lead-off detection functional block provides significant flexibility to choose from various lead-off detection strategies. Although called lead-off detection, this feature is in fact *electrode-off* detection.

The basic principle is to inject an excitation signal and measure the response to determine if the electrode is off. As shown in the lead-off detection functional block diagram in Figure 39, this circuit provides two different methods of determining the state of the patient electrode. The methods differ in the frequency content of the excitation signal. Lead-off can be selectively done on a per channel basis using the LOFF\_SENSP and LOFF\_SENSN registers. The internal excitation circuitry can be disabled while the sensing circuitry is enabled.

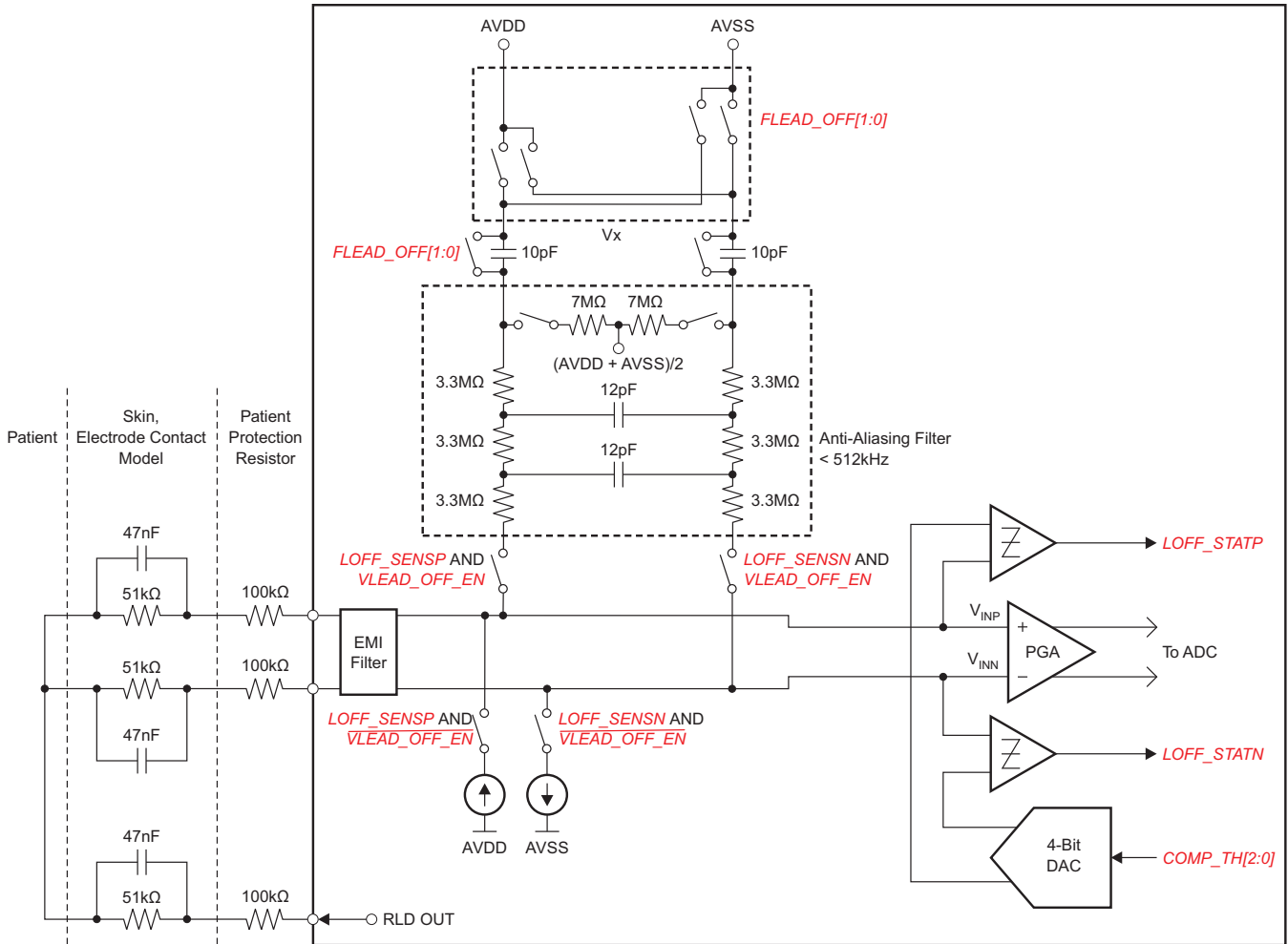
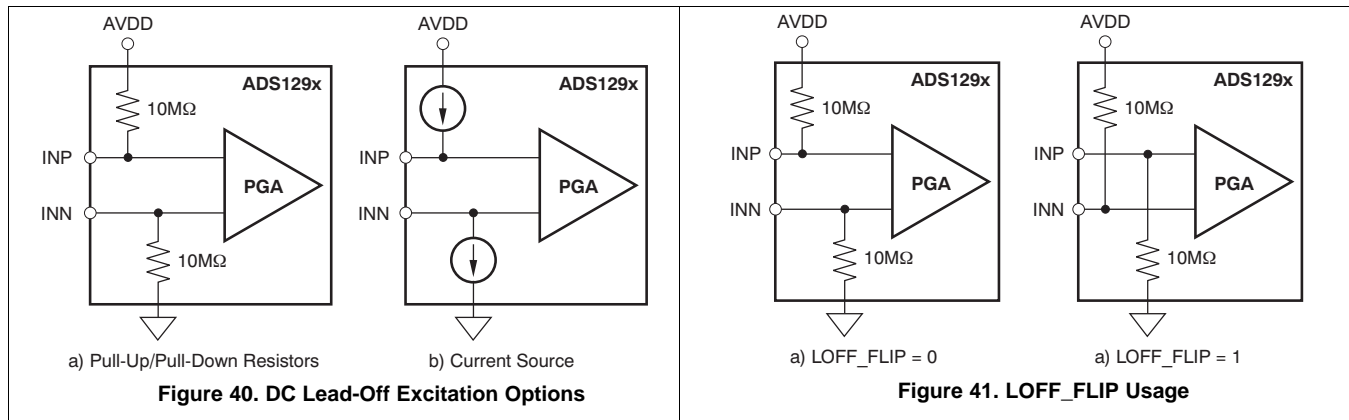

Figure 39. Lead-Off Detection

### 9.3.1.7.4.1 DC Lead-Off

In this approach, the lead-off excitation is accomplished with a dc signal. Choose a dc excitation signal from either a pullup or pulldown resistor, or from a current source or sink system, as shown in [Figure 40](#). Select by setting the VLEAD\_OFF\_EN bit in the LOFF register. One side of the channel is pulled to supply, and the other side is pulled to ground. Swap the pullup resistor and pulldown resistor by setting the bits in the LOFF\_FLIP register, as shown in [Figure 41](#). If using a current source or sink, set the magnitude of the current by using the ILEAD\_OFF[1:0] bits in the LOFF register. The current source or sink gives larger input impedance compared to the 10-M $\Omega$  pullup or pulldown resistor.



Response sensing is achieved either by looking at the digital output code from the device, or by monitoring the input voltages with on-chip comparators. If either of the electrodes is off, the pullup or pulldown resistors saturate the channel. Look at the output code to determine if either the P-side or the N-side is off. To pinpoint which side is off, check the comparator outputs. During conversion, the input voltage is simultaneously monitored by using a comparator and a 4-bit DAC with levels that are set by the COMP\_TH[2:0] bits in the LOFF register. The comparator outputs are stored in the LOFF\_STATP and LOFF\_STATN registers. These two registers are available as a part of the output data stream (see the [Data Output Pin \(DOUT\)](#) section). If dc lead-off is not used, the lead-off comparators can be powered down by setting the PD\_LOFF\_COMP bit in the CONFIG4 register.

An example procedure to turn on dc lead-off is given in the [Lead-Off](#) section.

### 9.3.1.7.4.2 AC Lead-Off

This method uses an out-of-band ac signal for excitation. The ac signal is generated by providing pullup and pulldown resistors at the input with a fixed frequency. The ac signal is passed through an antialiasing filter to prevent aliasing. Select the frequency with the FLEAD\_OFF[1:0] bits in the LOFF register. The excitation frequency is a function of the output data rate and is  $f_{DR} / 4$ . This out-of-band excitation signal is passed through the channel and measured at the output.

AC signal sensing is achieved by passing the signal through the channel to digitize the signal, and measuring the output. The ac excitation signals are introduced at a frequency that is above the band of interest, generating an out-of-band differential signal that can be filtered out separately and processed. By measuring the magnitude of the excitation signal at the output spectrum, the lead-off status is calculated. Therefore, the ac lead-off detection is accomplished simultaneously with the ECG signal acquisition.

### 9.3.1.7.5 RLD Lead-Off

Determine if the RLD electrode is connected in the ADS129x by powering down the RLD amplifier. After power down, there are two measurement procedures to determine the RLD electrode connect status: a pullup or pulldown resistor, or a sink or source current source, as shown in Figure 42. Set the reference level of the comparator to determine the acceptable RLD impedance threshold.

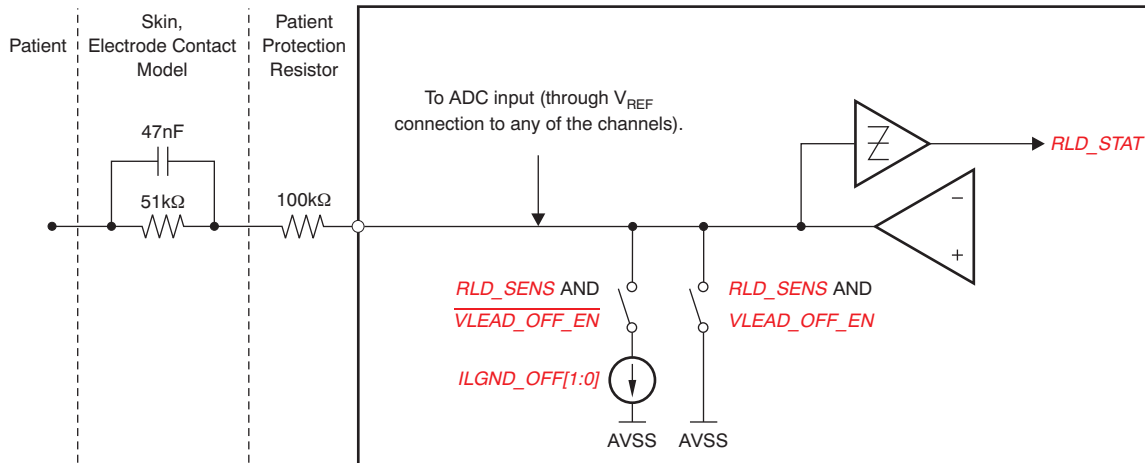

Figure 42. RLD Lead-Off Detection at Power Up

The current source, or pullup or pulldown resistor method has no function when the RLD amplifier is powered on. Use the comparator to sense the voltage at the output of the RLD amplifier. The comparator threshold is set by the same LOFF[7:5] bits that are used to set the thresholds for the other negative inputs.

### 9.3.1.7.6 Right Leg Drive (RLD) DC Bias Circuit

Use the right leg drive (RLD) circuitry to counter the common-mode interference in a ECG system as a result of power lines and other sources, including fluorescent lights. The RLD circuit senses the common-mode voltage of a selected set of electrodes and creates a negative feedback loop by driving the body with an inverted common-mode signal. The negative feedback loop restricts the common-mode movement to a narrow range, depending on the loop gain. Stabilizing the entire loop is specific to the individual system, based on the various poles in the loop. The ADS129x incorporate muxes that are used to select the channel to the operational amplifier. All the amplifier terminals are available at the pins, allowing selection of the components for the feedback loop. The circuit shown in Figure 43 shows the overall functional connectivity for the RLD bias circuit.

Set the reference voltage for the RLD to be generated internally ( $[AVDD + AVSS] / 2$ ), or provided externally with a resistive divider. The selection of an internal versus external reference voltage for the RLD loop is defined by writing the appropriate value to the RLDREF\_INT bit in the CONFIG3 register.

If the RLD function is not used, power down the amplifier using the PD\_RLD bit (see the [CONFIG3: Configuration Register 3 \(address = 03h\) \(reset = 40h\)](#) section for details). This bit is also used in daisy-chain mode to power down all but one of the RLD amplifiers.

The functionality of the RLDIN pin is explained in the [Input Multiplexer](#) section. An example procedure to use the RLD amplifier is shown in the [Right Leg Drive](#) section of the *Power-Supply Recommendations*.

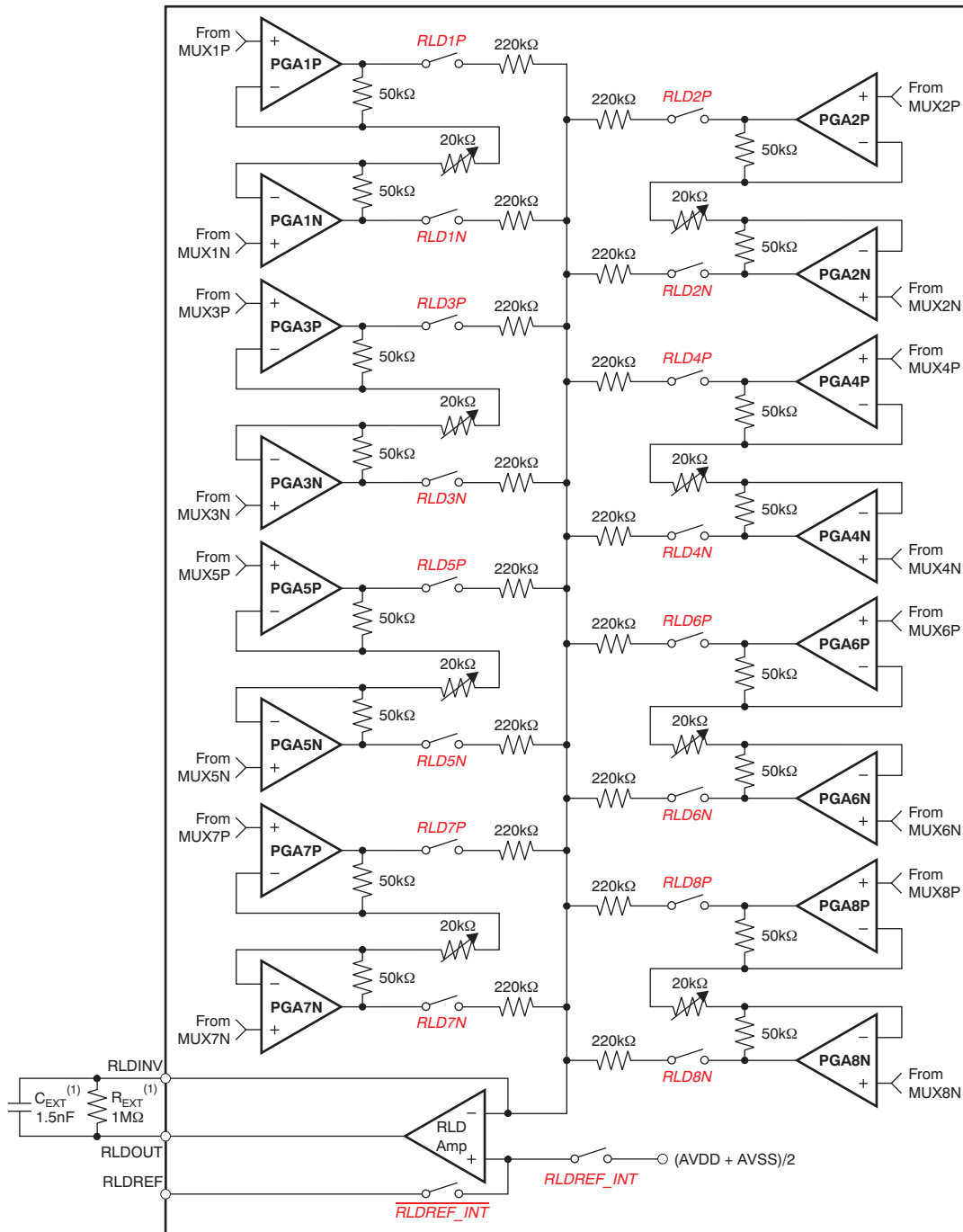

- (1) Typical values.
- (2) When CONFIG3 bit RLDREF\_INT = 0, the  $\overline{\text{RLDREF\_INT}}$  switch is closed and the RLDREF\_INT switch is open. When CONFIG3 bit RLDREF\_INT = 1, the  $\overline{\text{RLDREF\_INT}}$  switch is open and the RLDREF\_INT switch is closed.

Figure 43. RLD Channel Selection <sup>(2)</sup>



### 9.3.1.7.7 Pace Detect

The ADS129x provide flexibility for pace detection by using either software or external hardware. The software approach is made possible by providing sampling rates up to 32 kSPS. The external hardware approach is made possible by bringing out the output of the PGA at two pins: TESTP\_PACE\_OUT1 and TESTN\_PACE\_OUT2. If the WCT amplifier is connected to the signal path, switching noise occurs as a result of chopping; see the [Wilson Central Terminal \(WCT\) and Chest Leads](#) section for details.

#### 9.3.1.7.7.1 Software Approach

To use the software approach, operate the device at 8 kSPS or more to capture the fastest pulse. Afterwards, digital signal processing is used to identify the presence of the pacemaker pulse. The software approach gives the utmost flexibility to program the pace detect threshold *on-the-fly* (dynamically) using software. This flexibility is increasingly important as pacemakers evolve over time. Two parameters must be considered while measuring fast pace pulses:

1. PGA bandwidth: determines the gain setting that can be used; shown in [Table 5](#).
2. Settling time: determines the operating data rate for the device. For a step change in input, the digital decimation filter takes  $3 \times t_{DR}$  to settle.

#### 9.3.1.7.7.2 External Hardware Approach

One of the drawbacks of using the software approach is that all channels on a single device must operate at higher data rates. For systems where high data rates are a problem, the ADS129x provide the option of connecting external hardware to the output of the PGA to detect the presence of the pulse. The output of the pace detection logic is then fed into the device through one of the GPIO pins. The GPIO data are transmitted through the SPI port and loaded  $2 t_{CLKS}$  before  $\overline{DRDY}$  goes low. Two of the eight channels are selected using register bits in the PACE register: one from the odd-numbered channels, and the other from the even-numbered channels. During the differential to single-ended conversion, there is an attenuation of 0.4; therefore, the total gain in the pace path is equal to  $(0.4 \times \text{PGA\_GAIN})$ . The pace output signals are multiplexed with the TESTP and TESTN signals through the TESTP\_PACE\_OUT1 and TESTN\_PACE\_OUT2 pins, respectively. Channel selection is achieved by setting bits[4:1] of the PACE register. If the pace circuitry is not used, turn off the pace amplifiers by using the PD\_PACE bit in the PACE register.

If the output of a channel connected to the WCT amplifier (for example, the V-lead channels) is connected to one of the pace amplifiers for external pace detection, chopping artifacts appear at the pace amplifier output. See the [Wilson Central Terminal \(WCT\) and Chest Leads](#) section for more details.

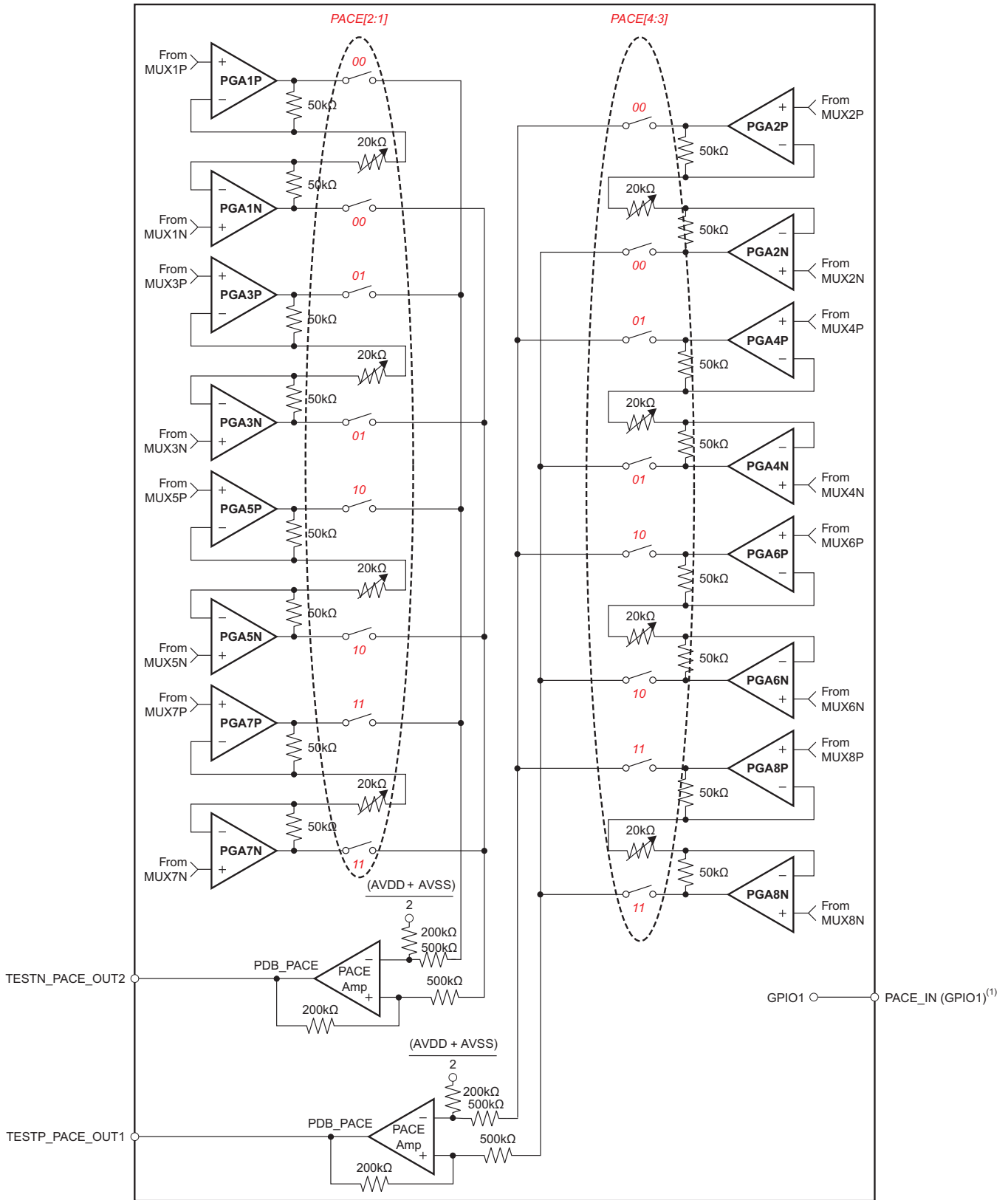

(1) GPIO1 can be used as the PACE\_IN signal.

**Figure 46. Hardware Pace Detection Option**

### 9.3.1.7.8 Respiration

As shown in [Table 8](#), the ADS129xR provide three options for respiration impedance measurement: external respiration, internal respiration using on-chip modulation signals, and internal respiration using user-generated modulation signals. The ADS129x provides only external respiration impedance measurement.

**Table 8. Respiration Control**

RESP.RESP_CTRL[1]	RESP.RESP_CTRL[0]	DESCRIPTION	MODE AVAILABLE
0	0	Respiration disabled	ADS129x, ADS129xR
0	1	Generates modulation and demodulation signals for external respiration circuitry. RESP_CLK signals on GPIO2, GPIO3, and GPIO4.	ADS129x, ADS129xR
1	0	Respiration measurement using internally-generated RESP_MOD signals.	ADS129xR
1	1	Respiration measurement using user-generated modulation and blocking signal.	ADS129xR <sup>(1)</sup>

(1) Do not set RESP\_CTRL[1:0] = 11 if CLKSEL = 1 (internal master clock).

For more information on respiration impedance measurement, see *Respiration Rate Measurement Using Impedance Pneumography*, [SBAA181](#).

#### 9.3.1.7.8.1 External Respiration Circuitry (RESP\_CTRL = 01b)

With this option, GPIO2, GPIO3, and GPIO4 are automatically configured as outputs. The phase relationship between the signals is shown in [Figure 47](#). GPIO2 is the exclusive-OR of GPIO3 and GPIO4, as shown in [Figure 48](#). GPIO3 is the modulation signal, and GPIO4 is the demodulation signal. While using this option, the general-purpose pin functions of GPIO2, GPIO3, and GPIO4 are not available. The modulation frequency is set to either 64 kHz or 32 kHz by using the RESP\_FREQ[2:0] bits in the CONFIG4 register. The remaining bit options of RESP\_FREQ[2:0] generate square waves on GPIO3 and GPIO4. The exclusive-OR out on GPIO2 is only available in 64-kHz or 32-kHz. The phase of GPIO4, relative to GPIO3, is set by RESP\_PH[2:0] bits in the RESP register.

Use this option to implement custom respiration impedance circuitry external to the ADS129x.

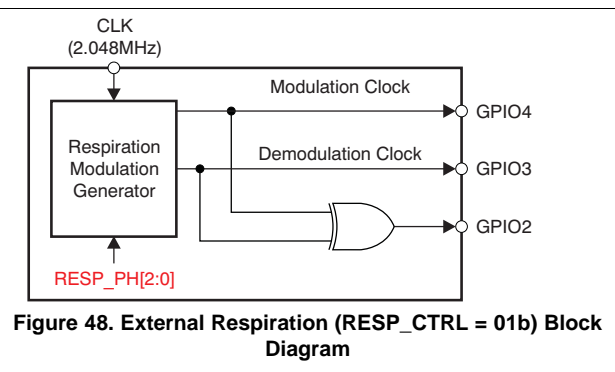
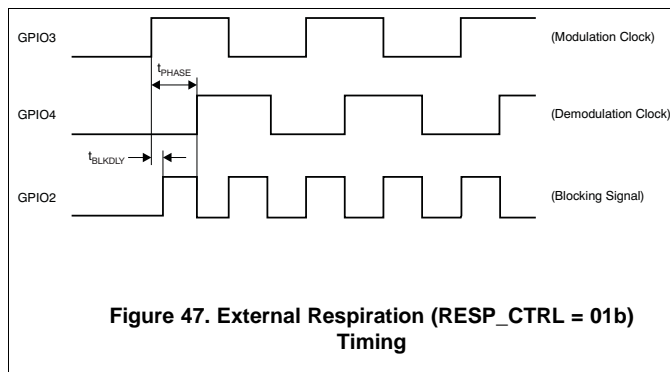

**Table 9. Switching Characteristics for [Figure 47](#)<sup>(1)</sup>**

PARAMETER	2.7 V ≤ DVDD ≤ 3.6 V			1.65 V ≤ DVDD ≤ 2 V			UNIT
	MIN	TYP	MAX	MIN	TYP	MAX	
t <sub>PHASE</sub>	Respiration phase delay, set by RESP.RESP_PH[2:0]		22.5	157.5	22.5	157.5	Degrees
t <sub>BLKDLY</sub>	Modulation clock rising edge to XOR signal		1		5		ns

(1) Specifications apply from –40°C to 85°C.

9.3.1.7.8.2 Internal Respiration Circuitry with Internal Clock (RESP\_CTRL = 10b, ADS129xR Only)

Figure 49 shows a block diagram of the internal respiration circuitry. The internal modulation and demodulator circuitry can be selectively used.

The modulation block is controlled by the RESP\_MOD\_EN bit and the demodulation block is controlled by the RESP\_DEMOD\_EN bit. The modulation signal is a square wave of magnitude VREFP – AVSS. Using this option, the output of the modulation circuitry is available at the RESP\_MODP and RESP\_MODN pins of the device. This availability allows custom filtering to be added to the square-wave modulation signal. Using this option, GPIO2, GPIO3, and GPIO4 can be used for other purposes. The modulation frequency is either 64 kHz or 32 kHz, as set by the RESP\_FREQ[2:0] bits in the CONFIG4 register. The phase of the internal demodulation signal is set by the RESP\_PH[2:0] bits in the RESP register.

When this respiration option is enabled, ADS129xR channel 1 cannot be used to acquire ECG signals. If the RA and LA leads are intended to measure respiration and ECG signals, wire the two leads into channel 1 for respiration and channel 2 for ECG signals.

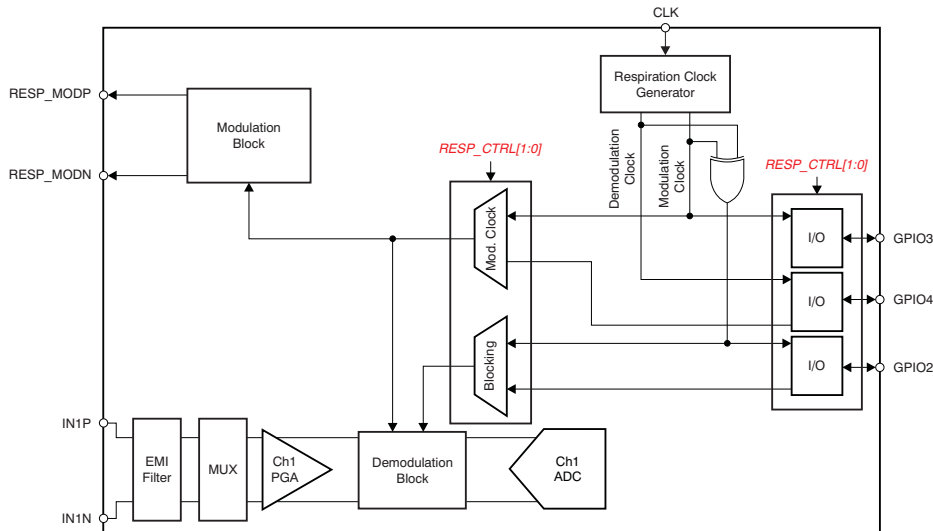

Figure 49. Internal Respiration Block Diagram

9.3.1.7.8.3 Internal Respiration Circuitry With User-Generated Signals (RESP\_CTRL = 11b, ADS129xR Only)

In this mode GPIO2, GPIO3, and GPIO4 are automatically configured as inputs and cannot be used for other purposes. The signals must be provided as described in Figure 50. Do not use the internal master clock in this mode.

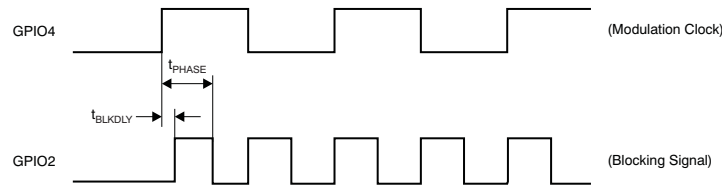

Figure 50. Internal Respiration (RESP\_CTRL = 11b) Timing Diagram

Table 10. Switching Characteristics for Figure 50 (1)

PARAMETER		1.65 V ≤ DVDD ≤ 3.6V			UNIT
		MIN	TYP	MAX	
t <sub>PHASE</sub>	Respiration phase delay	0		157.5	Degrees
t <sub>BLKDLY</sub>	Modulation clock rising edge to XOR signal		0	5	ns

(1) Specifications apply from –40°C to 85°C.

## 9.3.2 Digital Functionality

### 9.3.2.1 GPIO Pins (GPIO[4:1])

The ADS129x have a total of four general-purpose digital input/output (GPIO) pins available in normal operation. The digital I/O pins are individually configurable as either inputs or as outputs through the GPIOC bits of the GPIO register. The GPIOD bits in the GPIO register control the level of the pins. When reading the GPIOD bits, the data returned are the logic level of the pins, whether they are programmed as inputs or outputs. When the GPIO pin is configured as an input, a write to the corresponding GPIOD bit has no effect. When configured as an output, a write to the GPIOD bit sets the output value.

If configured as inputs, these pins must be driven; do not float these pins. The GPIO pins are set as inputs after power-on or after a reset. [Figure 51](#) shows the GPIO port structure. If not used, short these pins to DGND.

For example, one configuration is to use GPIO1 as the PACEIN signal, multiplex GPIO2 with RESP\_BLK signal, multiplex GPIO3 with the RESP signal, and multiplex GPIO4 with the RESP\_PH signal.

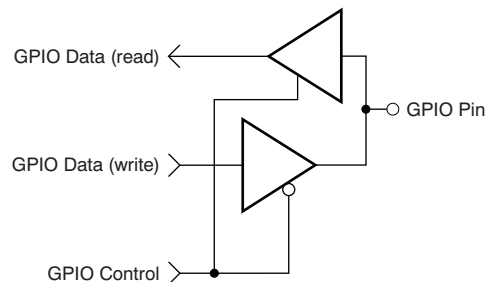

**Figure 51. GPIO Port Pin**

### 9.3.2.2 Power-Down Pin ( $\overline{PWDN}$ )

When  $\overline{PWDN}$  is pulled low, all on-chip circuitry is powered down. To exit power-down mode, take the  $\overline{PWDN}$  pin high. Upon exiting from power-down mode, the internal oscillator and the reference require time to wakeup. During power down, shut down the external clock to save power.

### 9.3.2.3 Reset ( $\overline{RESET}$ Pin and Reset Command)

There are two methods to reset the ADS129x: pull the  $\overline{RESET}$  pin low, or send the RESET opcode command (see the [RESET: Reset Registers to Default Values](#) section). Take the  $\overline{RESET}$  pin low to force a reset. Make sure to follow the minimum pulse width timing specifications before taking the  $\overline{RESET}$  pin back high. The RESET command takes effect on the eighth SCLK falling edge of the opcode command. At reset, 18  $t_{CLK}$  cycles are required to complete initialization of the configuration registers to the default states and start the conversion cycle. For more information, see the [RESET: Reset Registers to Default Values](#) section. An internal reset is automatically issued to the digital filter whenever registers CONFIG1 and RESP are set to new values with a WREG command.

### 9.3.2.4 Digital Decimation Filter

The digital filter receives the modulator output and decimates the data stream. By adjusting the amount of filtering, tradeoffs are made between resolution and data rate: filter more for higher resolution, filter less for higher data rates. Higher data rates are typically used in ECG applications to implement software pace detection and ac lead-off detection.

The digital filter on each channel consists of a third-order sinc filter. The decimation ratio on the sinc filters is adjusted by the DR bits in the CONFIG1 register (see Table 16 for details). This setting is a global setting that affects all channels; therefore, in these devices, all channels operate at the same data rate.

#### 9.3.2.4.1 Sinc Filter Stage (sinc / x)

The sinc filter is a variable-decimation rate, third-order, low-pass filter. Data are supplied to this section of the filter from the modulator at the rate of  $f_{MOD}$ . The sinc filter attenuates the high-frequency noise of the modulator, then decimates the data stream into parallel data. The decimation rate affects the overall data rate of the converter.

Equation 4 shows the scaled Z-domain transfer function of the sinc filter.

$$|H(z)| = \left| \frac{1 - Z^{-N}}{1 - Z^{-1}} \right|^3 \quad (4)$$

The frequency-domain transfer function of the sinc filter is shown in Equation 5.

$$|H(f)| = \left| \frac{\sin \left[ \frac{N\pi f}{f_{MOD}} \right]}{N \times \sin \left[ \frac{\pi f}{f_{MOD}} \right]} \right|^3$$

where

- N = decimation ratio (5)

The sinc filter has notches (or zeroes) that occur at the output data rate multiples. At these frequencies, the filter has infinite attenuation. Figure 52 shows the frequency response of the sinc filter and Figure 53 shows the rolloff of the sinc filter. With a step change at input, the filter requires  $3 \times t_{DR}$  conversion cycles to settle. After a rising edge of the START pin or completion of the START command, the filter takes  $t_{SETTLE}$  periods to give the first data output. The settling time of the filters at various data rates are discussed in the Start Mode subsection of the SPI Interface section. Figure 54 and Figure 55 show the filter transfer function to  $f_{MOD} / 2$  and  $f_{MOD} / 16$ , respectively, at different data rates. Figure 56 shows the transfer function extended out to  $4 \times f_{MOD}$ . As shown in the figures, the passband of the ADS129x repeats itself at every  $f_{MOD}$  multiple. Choose input R-C antialiasing filters for the system that sufficiently attenuate any interference in frequencies around multiples of  $f_{MOD}$ .

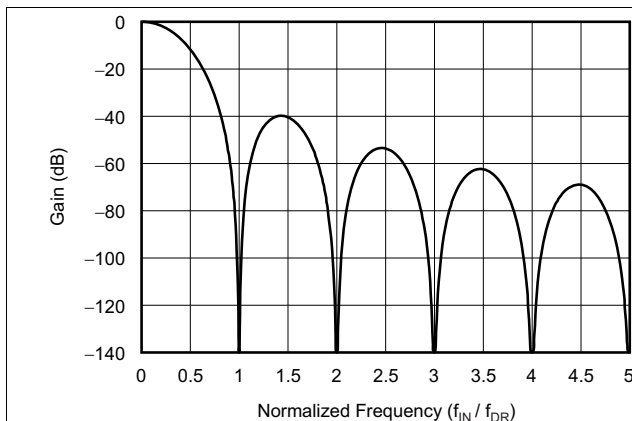

Figure 52. Sinc Filter Frequency Response

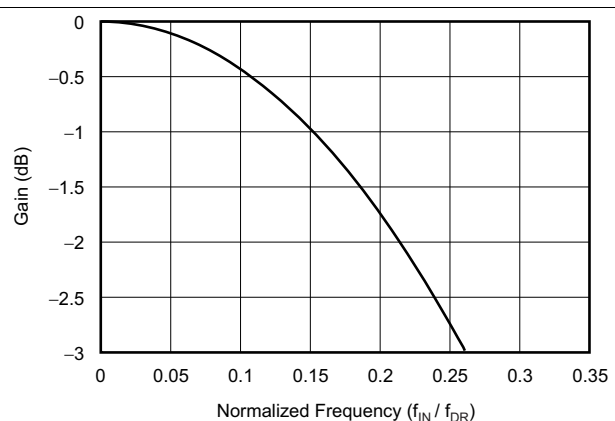

Figure 53. Sinc Filter Roll-Off

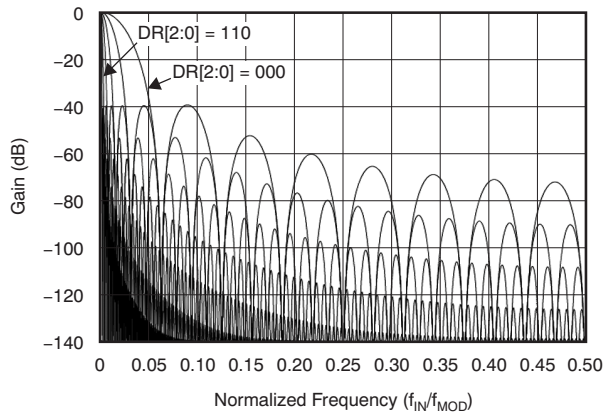

Figure 54. Transfer Function of On-Chip Decimation Filters to  $f_{MOD} / 2$

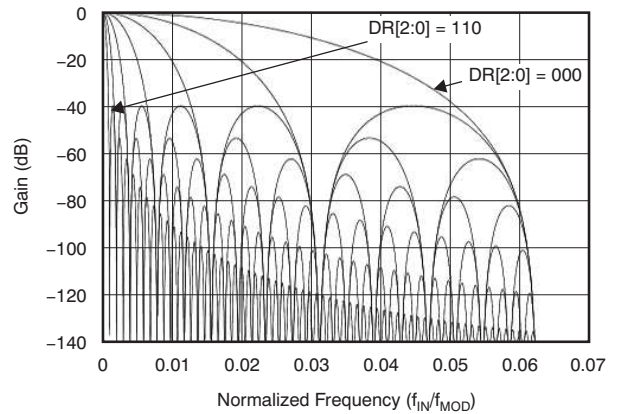

Figure 55. Transfer Function of On-Chip Decimation Filters to  $f_{MOD} / 16$

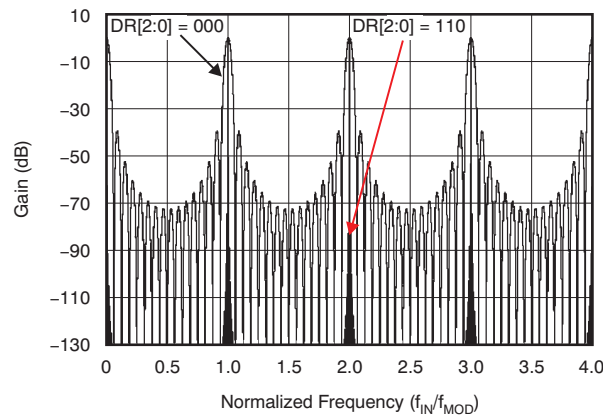

Figure 56. Transfer Function of On-Chip Decimation Filters to  $4 \times f_{MOD}$  for DR[2:0] = 000 and DR[2:0] = 110

### 9.3.2.5 Clock

The ADS129x provide two different methods for device clocking: internal and external. Internal clocking is ideally suited for low-power, battery-powered systems. The internal oscillator is trimmed for accuracy at room temperature. The accuracy varies over the specified temperature range; see the [Electrical Characteristics](#). Clock selection is controlled by the CLKSEL pin and the CLK\_EN register bit.

Use the CLKSEL pin to select either the internal or external clock. The CLK\_EN bit in the CONFIG1 register enables and disables the oscillator clock to be output in the CLK pin. A truth table for these two pins is shown in [Table 11](#). Use the CLK\_EN bit is when multiple devices are connected in a daisy-chain configuration. During power down, shut down the external clock to save power.

Table 11. CLKSEL Pin and CLK\_EN Bit

CLKSEL PIN	CONFIG1.CLK_EN BIT	CLOCK SOURCE	CLK PIN STATUS
0	X	External clock	Input: external clock
1	0	Internal clock oscillator	Tri-state
1	1	Internal clock oscillator	Output: internal clock oscillator

## 9.4 Device Functional Modes

### 9.4.1 Data Acquisition

This section describes the data acquisition process in relation to the START and  $\overline{\text{DRDY}}$  pins, settled data, and data readback.

#### 9.4.1.1 Start Mode

Pull the START pin high for at least 2  $t_{\text{CLK}}$  periods, or send the START command to begin conversions. When the START pin is low, or if the START command has not been sent, the device does not issue a DRDY signal (conversions are halted).

When using the START opcode to begin conversions, hold the START pin low. The ADS129x feature two modes to control conversion: continuous and single-shot. The mode is selected by SINGLE\_SHOT (bit 3 of the CONFIG4 register). In multiple device configurations, the START pin is used to synchronize devices (see the [Multiple-Device Configuration](#) section for more details).

##### 9.4.1.1.1 Settling Time

The settling time ( $t_{\text{SETTLE}}$ ) is the time it takes for the converter to output fully-settled data when the START signal is pulled high.

When the START pin is pulled high, or when the START command is sent, the device ADCs convert the input signals and DRDY is pulled high. The next falling edge of DRDY indicates that data are ready. [Figure 57](#) shows the timing diagram and [Table 12](#) shows the settling time for different data rates as a function of  $t_{\text{CLK}}$ . The settling time depends on  $f_{\text{CLK}}$  and the decimation ratio (controlled by the DR[2:0] bits in the CONFIG1 register).

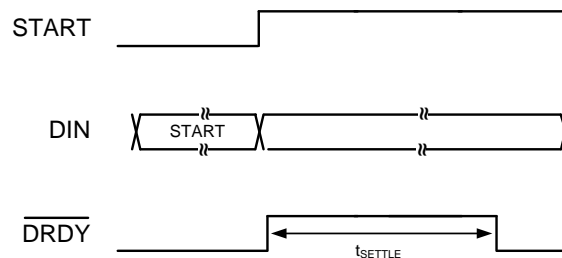
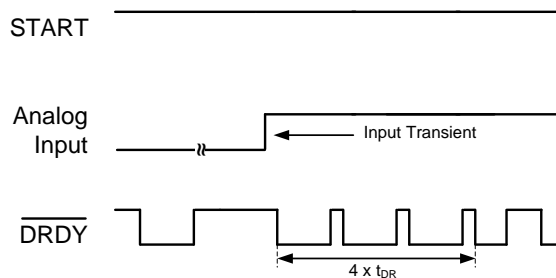

Figure 57. Settling Time for Initial Conversion

Table 12. Settling Times for Different Data Rates ( $t_{\text{SETTLE}}$ )

DR[2:0]	SETTLING TIME ( $t_{\text{CLK}}$ Periods)	
	HIGH-RESOLUTION MODE	LOW-POWER MODE
000	296	584
001	584	1160
010	1160	2312
011	2312	4616
100	4616	9224
101	9224	18440
110	18440	36872

When the START pin is held high and there is a step change in the input signal,  $3 \times t_{DR}$  conversion cycles are required for the filter to settle to the new value, as shown in Figure 58. Settled data are available on the fourth DRDY pulse. This settling time must be considered when trying to measure narrow pace pulses for pace detection. Data are available to read at each DRDY high-to-low transition, but can be ignored.



**Figure 58. Settling Time for Input Transient**

#### 9.4.1.2 Data Ready Pin ( $\overline{DRDY}$ )

$\overline{DRDY}$  is an output. When  $\overline{DRDY}$  transitions low, new conversion data are ready. The  $\overline{CS}$  signal has no effect on the data ready signal. Regardless of the status of the  $\overline{CS}$  signal, a rising edge on SCLK pulls  $\overline{DRDY}$  high. Thus, when using multiple devices in the SPI bus, gate SCLK with CS. The behavior of  $\overline{DRDY}$  depends on if the device is in RDATA mode or if the RDATA command is being used to read data on demand. See the [RDATA: Read Data Continuous](#) and [RDATA: Read Data](#) sections for further details.

When reading data with the RDATA command, the read operation can overlap the occurrence of the next  $\overline{DRDY}$  without data corruption.

Use the START pin or the START command to place the device either in normal data capture mode or pulse data capture mode.

Figure 59 shows the relationship among  $\overline{DRDY}$ , DOUT, and SCLK during data retrieval (in the case of an ADS129x with a selected data rate that gives 24-bit resolution). DOUT latches at the rising edge of SCLK. The device pulls  $\overline{DRDY}$  high at the first falling edge of SCLK, regardless of whether data are being retrieved from the device or a command is being sent through the DIN pin. The data starts from the MSB of the status word and then proceeds to the ADC channel data in sequential order (that is, channel 1, channel 2, ..., channel x). Channels that are powered down still have a position in the data stream; however, the data are not valid and can be ignored.

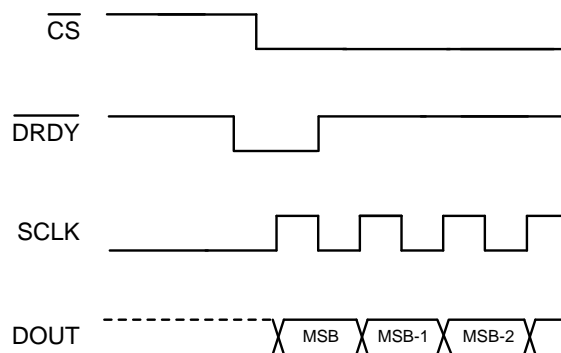

**Figure 59.  $\overline{DRDY}$  with Data Retrieval ( $\overline{CS} = 0$ )**

The  $\overline{\text{DRDY}}$  signal is cleared on the first SCLK falling edge, regardless of the state of  $\overline{\text{CS}}$ . Even if no data are clocked out, the  $\overline{\text{DRDY}}$  signal is still cleared. Take this condition into consideration if the SPI bus is used to communicate with other devices on the same bus. Figure 60 shows a timing diagram for this multiplexing.

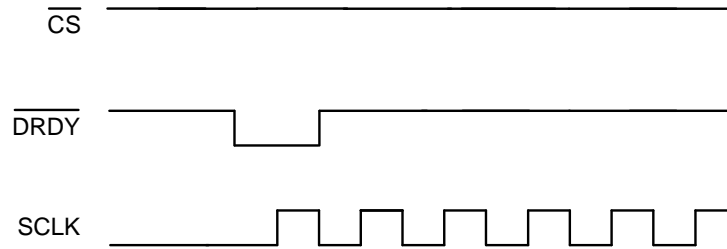

Figure 60.  $\overline{\text{DRDY}}$  and SCLK Behavior for SPI Bus Multiplexing

### 9.4.1.3 Data Retrieval

Data retrieval is accomplished in one of two methods:

1. RDATA: the read data continuous command sets the device mode that reads data continuously without sending opcodes. See the [RDATA: Read Data Continuous](#) section for more details.
2. RDATA: the read data command reads just one data output from the device. See the [RDATA: Read Data](#) section for more details.

See the [SPI Command Definitions](#) section for more details.

The conversion data are read by shifting the data out on DOUT. The MSB of the data on DOUT is clocked out on the first SCLK rising edge.  $\overline{\text{DRDY}}$  returns to high on the first SCLK falling edge. Keep DIN low for the entire read operation.

#### 9.4.1.3.1 Status Word

The ADS129x data readback is preceded by a status word that provides information on the state of the ADC. The status word is 24 bits long and contains the values for LOFF\_STATP, LOFF\_STATN, and part of the GPIO registers. The content alignment is shown in Figure 61.

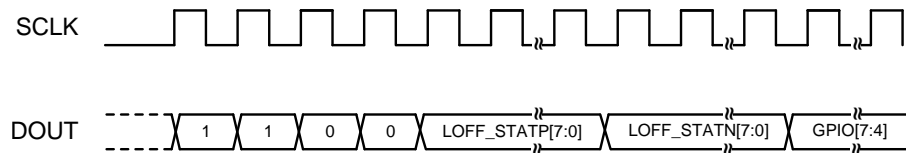

Figure 61. Status Word Content

#### 9.4.1.3.2 Readback Length

The number of bits in the data output depends on the number of channels and the number of bits per channel. The data format for each channel data is two's complement and MSB first. For the ADS129x with 32-kSPS and 64-kSPS data rates, the number of data bits is 24 status bits + 16 bits per channel × 8 channels = 152 bits. For all other data rates, the number of data bits is 24 status bits + 24 bits per channel × 8 channels = 216 bits. When channels are powered down using the user-register setting, the corresponding channel output is set to 0. However, the sequence of channel outputs remains the same. The ADS1294 outputs four channels of data and the ADS1296 outputs six channels of data.

The ADS129x also provide a multiple-readback feature. Set the DAISY\_IN bit in the CONFIG1 register to 1 for multiple readbacks. Simply provide additional SCLKs to read data multiple times; the MSB data byte repeats after reading the last byte.

### 9.4.1.3.3 Data Format

The ADS129x output 24 bits of data per channel in binary two's complement format, MSB first. The LSB has a weight of  $V_{REF} / (2^{23} - 1)$ . A positive full-scale input produces an output code of 7FFFFFFh and the negative full-scale input produces an output code of 800000h. The output clips at these codes for signals exceeding full-scale. [Table 13](#) summarizes the ideal output codes for different input signals. For DR[2:0] = 000 and 001, the device has only 17 and 19 bits of resolution, respectively. The last seven (in 17-bit mode) or five (in 19-bit mode) bits can be ignored.

**Table 13. Ideal Output Code versus Input Signal<sup>(1)</sup>**

INPUT SIGNAL, $V_{IN}$ ( $IN_{xP} - IN_{xN}$ )	IDEAL OUTPUT CODE <sup>(2)</sup>
$\geq V_{REF}$	7FFFFFFh
$V_{REF} / (2^{23} - 1)$	000001h
0	000000h
$-V_{REF} / (2^{23} - 1)$	FFFFFFFh
$\leq -V_{REF} (2^{23} / (2^{23} - 1))$	800000h

(1) Only valid for 24-bit resolution data rates, with gain = 1.

(2) Excludes effects of noise, linearity, offset, and gain error.

### 9.4.1.4 Single-Shot Mode

Enable single-shot mode by setting the SINGLE\_SHOT bit in CONFIG4 register to 1. In single-shot mode, the ADS129x perform a single conversion when the START pin is taken high, or when the START opcode command is sent. As seen in [Figure 62](#), when a conversion completes,  $\overline{DRDY}$  goes low and further conversions are stopped. Regardless of whether the conversion data are read or not,  $\overline{DRDY}$  remains low. To begin a new conversion, take the START pin low and then back high for at least two  $t_{CLKS}$ , or transmit the START opcode again. When switching from continuous conversion mode to single-shot mode, make sure the START signal is pulsed, or issue a STOP command followed by a START command.

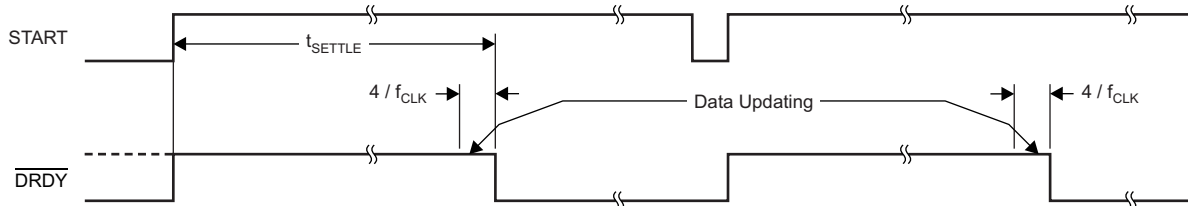
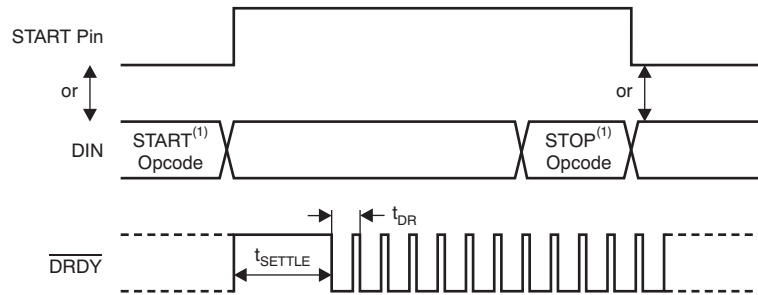

**Figure 62.  $\overline{DRDY}$  With No Data Retrieval in Single-Shot Mode**

Single-shot conversion mode is provided for applications that require nonstandard or noncontinuous data rates. Issue a START command or toggle the START pin high to reset the digital filter, effectively dropping the data rate by a factor of four. This mode leaves the system more susceptible to aliasing effects, thus requiring more complex analog or digital filtering. Loading on the host processor increases because it must toggle the START pin or send a START command to initiate a new conversion cycle.

### 9.4.1.5 Continuous Conversion Mode

Conversions begin when the START pin is taken high for at least two  $t_{CLKS}$ , or when the START opcode command is sent. As seen in Figure 63, the  $\overline{DRDY}$  output goes high when conversions are started and goes low when data are ready. Conversions continue indefinitely until the START pin is taken low or the STOP opcode command is transmitted. When the START pin is pulled low or the stop command is issued, the conversion in progress is allowed to complete. Figure 64 and Table 14 show the required timing of  $\overline{DRDY}$  to the START pin and the START and STOP opcode commands when controlling conversions in this mode. To keep the converter running continuously, permanently tie the START pin high. When switching from single-shot mode to continuous-conversion mode, pulse the START signal or a issue a STOP command followed by a START command. This conversion mode is ideal for applications that require a continuous stream of conversions results.



- (1) START and STOP opcode commands take effect on the seventh SCLK falling edge.

**Figure 63. Continuous Conversion Mode**

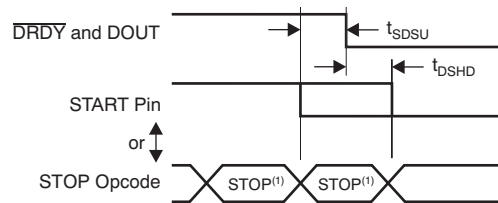

- (1) START and STOP commands take effect on the seventh SCLK falling edge at the end of the opcode transmission.

**Figure 64. START to  $\overline{DRDY}$  Timing**

**Table 14. Timing Requirements for Figure 64 <sup>(1)</sup>**

		MIN	MAX	UNIT
$t_{SDSU}$	START pin low or STOP opcode to $\overline{DRDY}$ setup time to halt further conversions	16		$t_{CLK}$
$t_{DSHD}$	START pin low or STOP opcode to complete current conversion	16		$t_{CLK}$

- (1) START and STOP commands take effect on the seventh SCLK falling edge at the end of the opcode transmission.

### 9.4.2 Multiple-Device Configuration

The ADS129x provide configuration flexibility when multiple devices are connected in a system. The serial interface typically requires four signals: DIN, DOUT, SCLK, and CS. With one additional chip select signal per device, multiple devices can be connected together. The number of signals required to interface  $n$  devices is  $3 + n$ .

Daisy-chain the RLD amplifiers as explained in the [RLD Configuration with Multiple Devices](#) section. To use the internal oscillator in a daisy-chain configuration, set one of the devices as the master for the clock source with the internal oscillator enabled (CLKSEL pin = 1) and the internal oscillator clock brought out of the device by setting the CLK\_EN register bit to 1. Use this master device clock as the external clock source for the other devices.

When using multiple devices, synchronize the devices with the START signal. The delay from the START signal to the  $\overline{\text{DRDY}}$  signal is fixed for a fixed data rate (see the [Start Mode](#) section for more details on the settling times). As an example, [Figure 65](#) shows the behavior of two devices when synchronized with the START signal.

There are two configurations used to connect multiple devices with a optimal number of interface pins: cascade or daisy-chain.

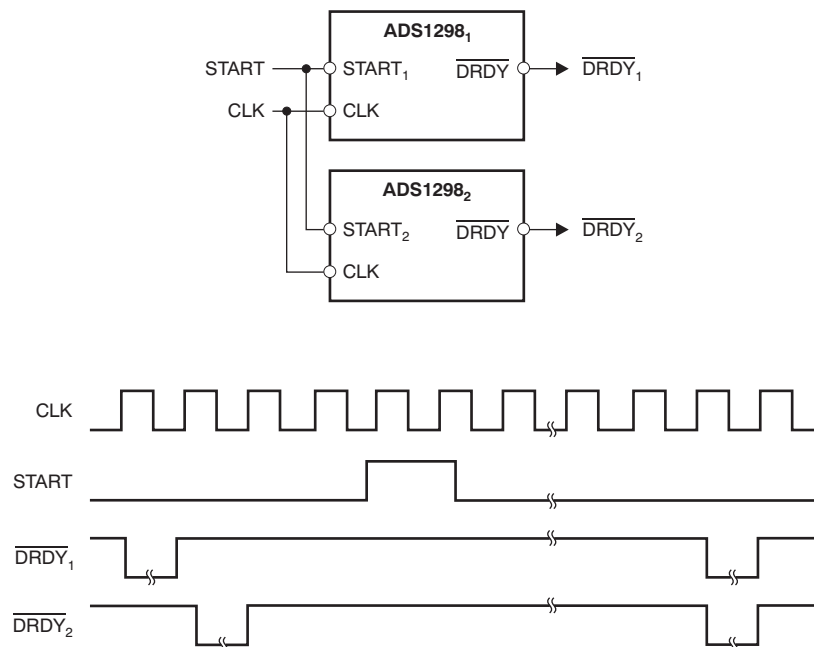

**Figure 65. Synchronizing Multiple Converters**

### 9.4.2.1 Cascade Configuration

Figure 66(a) shows a configuration with two devices cascaded together. One of the devices is an ADS1298 (eight channels) and the other is an ADS1294 (four channels). Together, they create a system with 12 channels. DOUT, SCLK, and DIN are shared. Each device has its own chip select. When a device is not selected by the corresponding  $\overline{CS}$  being driven to logic 1, the DOUT of this device is high-impedance. This structure allows the other device to take control of the DOUT bus. This configuration method is suitable for the majority of applications.

### 9.4.2.2 Daisy-Chain Configuration

Enable daisy-chain mode by setting the  $\overline{DAISY\_EN}$  bit in the CONFIG1 register. Figure 66(b) shows the daisy-chain configuration. In this configuration, SCLK, DIN, and  $\overline{CS}$  are shared across multiple devices. Connect the DOUT pin of the first device to the DAISY\_IN pin of the next device, thereby creating a chain. Issue one extra SCLK between each data set. Note that when using daisy-chain mode, the multiple readback feature is not available. Short the DAISY\_IN pin to digital ground if not used. Figure 2 describes the required timing for the ADS1298 shown in Figure 67. Data from the ADS1298 appear first on DOUT, followed by a *don't care* bit, and finally by the status and data words from the ADS1294.

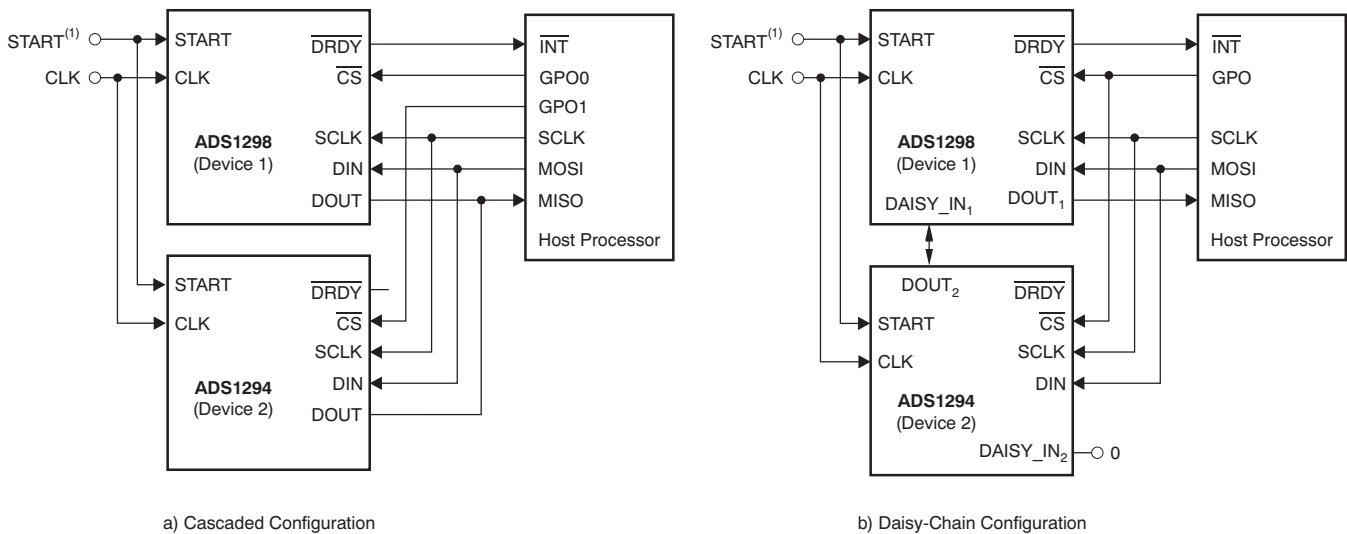

- (1) To reduce pin count, set the START pin low and use the START opcode command to synchronize and start conversions.

Figure 66. Multiple Device Configurations

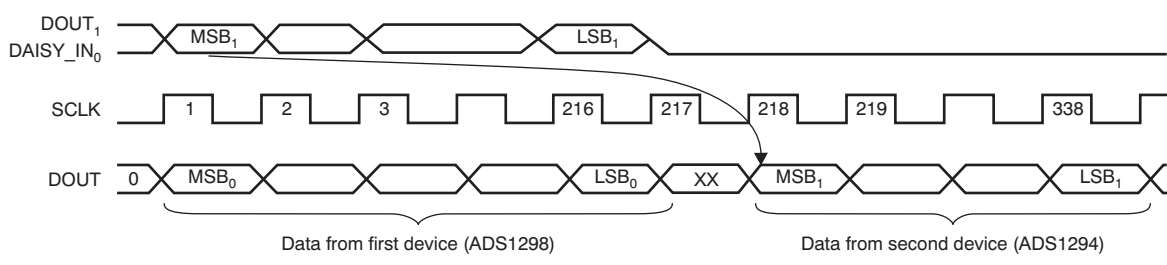

Figure 67. Daisy-Chain Timing for Figure 66(b)

Important reminders when using daisy-chain mode:

1. Issue one extra SCLK between each data set (see Figure 67).
2. All devices are configured to the same register values because  $\overline{CS}$  is shared.
3. Device register readback (RREG) is only valid for device 0 in the daisy chain. Only conversion data can be read from device 1 to device N, where N is the last device in the chain; register data cannot be read.

If all devices in the chain operate in the same register setting, DIN can be shared, thereby reducing the SPI communication signals to four, regardless of the number of devices. However, the individual devices cannot be programmed; therefore, the RLD driver cannot be shared among the multiple devices. Furthermore, an external clock must be used.

As shown in [Figure 2](#), the SCLK rising edge shifts data out of the ADS129x on DOUT. The SCLK rising edge is also used to latch data into the device DAISY\_IN pin down the chain. This architecture allows for a faster SCLK rate speed, but it also makes the interface sensitive to board-level signal delays. The more devices in the chain, the more challenging it becomes to adhere to setup and hold times. A star-pattern connection of SCLK to all devices, minimizing length of DOUT, and other PCB layout techniques help. Placing delay circuits such as buffers between DOUT and DAISY\_IN is another way to mitigate this challenge. One other option is to insert a *D* flip-flop between DOUT and DAISY\_IN clocked on an inverted SCLK. In addition, note that daisy-chain mode requires some software overhead to recombine data bits spread across byte boundaries.

The maximum number of daisy-chained devices depends on the data rate at which the device is operated. The maximum number of devices can be estimated with [Equation 6](#):

$$N_{\text{DEVICES}} = \frac{f_{\text{SCLK}}}{f_{\text{DR}} (N_{\text{BITS}})(N_{\text{CHANNELS}}) + 24}$$

where

- $N_{\text{BITS}}$  = device resolution (depends on data rate)
- $N_{\text{CHANNELS}}$  = number of channels in the device (4, 6, or 8) (6)

For example, when the ADS1298 (eight-channel, 24-bit version) is operated at a 2-kSPS data rate with a 4-MHz  $f_{\text{SCLK}}$ , up to ten devices can be daisy-chained.

## 9.5 Programming

### 9.5.1 SPI Interface

The SPI-compatible serial interface consists of four signals:  $\overline{CS}$ , SCLK, DIN, and DOUT. The interface reads conversion data, reads and writes registers, and controls the ADS129x operation. The  $\overline{DRDY}$  output is used as a status signal to indicate when data are ready.  $\overline{DRDY}$  goes low when new data are available.

#### 9.5.1.1 Chip Select Pin ( $\overline{CS}$ )

Chip select ( $\overline{CS}$ ) selects the ADS129x devices for SPI communication. While  $\overline{CS}$  is low, the serial interface is active.  $\overline{CS}$  must remain low for the entire duration of the serial communication. After the serial communication is finished, always wait four or more  $t_{CLK}$  periods before taking  $\overline{CS}$  high. When  $\overline{CS}$  is taken high, the serial interface resets, SCLK and DIN are ignored, and DOUT enters a high-impedance state.  $\overline{DRDY}$  asserts when data conversion is complete, regardless of whether  $\overline{CS}$  is high or low.

While ADS129x is selected, the device attempts to decode and execute commands every eight serial clocks. If the device ceases to execute serial commands, it is possible extra clock pulses were presented that placed the serial interface into an unknown state. To reset the serial interface to a known state, take  $\overline{CS}$  high and back low again.

#### 9.5.1.2 Serial Clock (SCLK)

SCLK is the serial peripheral interface (SPI) serial clock. It is used to shift in commands and shift out data from the device. The serial clock (SCLK) features a Schmitt-triggered input, and clocks data on the DIN and DOUT pins into and out of the ADS129x. Even though the input has hysteresis, keep SCLK as clean as possible to prevent glitches from accidentally forcing a clock event. The absolute maximum limit for SCLK is specified in the [Timing Requirements: Serial Interface](#) table.

While ADS129x is selected ( $\overline{CS} = \text{low}$ ), the device attempts to decode and execute commands every eight serial clocks. Therefore, present multiples of eight SCLKs every serial transfer to keep the interface in a normal operating mode. If the interface ceases to function because of extra serial clocks, reset by toggling  $\overline{CS}$  high and back low.

For a single device, the minimum speed required for SCLK depends on the number of channels, number of bits of resolution, and output data rate. For multiple cascaded devices, see the [Cascade Configuration](#) section. [Equation 7](#) shows the calculation for minimum SCLK speed.

$$t_{SCLK} < (t_{DR} - 4t_{CLK}) / (N_{BITS} \times N_{CHANNELS} + 24) \quad (7)$$

For example, if the ADS1298 is used at 500-SPS (eight channels, 24-bit resolution), the minimum SCLK speed is 110 kHz.

Retrieve data either by putting the device in RDATA mode or by issuing a RDATA command for data on demand. The SCLK rate limitation of [Equation 7](#) also applies to RDATA. For the RDATA command, the limitation applies if data must be read between two consecutive  $\overline{DRDY}$  signals. [Equation 7](#) assumes that there are no other commands issued between data captures.

## Programming (continued)

### 9.5.1.2.1 SCLK Clocking Methods

As shown in Figure 68, there are two different SCLK clocking methods to satisfy the decode timing specification shown in Figure 1 for multiple-byte commands.

For SCLK speeds that meet the  $t_{SDECODE}$  timing requirement shown in Figure 1, transmit SCLK in a continuous stream when  $\overline{CS}$  is low. This method is not to be confused with a free-running SCLK, where SCLK operates when  $\overline{CS}$  is high. Free-running SCLK operation is not supported by this device.

For faster SCLK speeds that do not meet the  $t_{SDECODE}$  timing requirement, SCLK is transmitted in 8-bit bursts with a delay between bursts. The absolute maximum SCLK limit is specified in the *Timing Requirements: Serial Interface* table. Figure 68 shows the difference between the two SCLK clocking methods for this device.

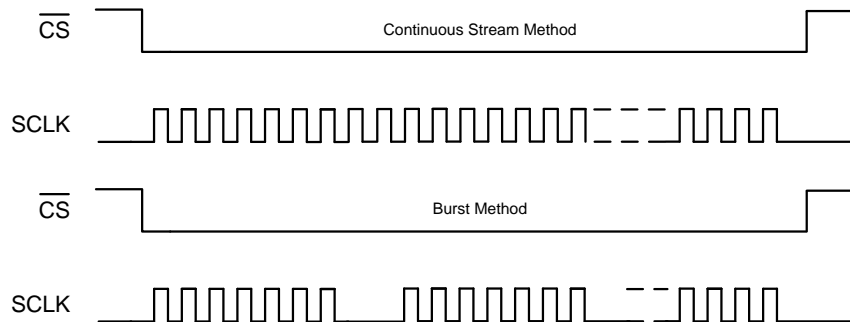

Figure 68. SCLK Clocking Methods

### 9.5.1.3 Data Input Pin (DIN)

The data input pin (DIN) is used along with SCLK to communicate with the ADS129x (opcode commands and register data). The device latches data on DIN on the falling edge of SCLK.

### 9.5.1.4 Data Output Pin (DOUT)

The data output pin (DOUT) is used with SCLK to read conversion and register data from the ADS129x. Data on DOUT are shifted out on the rising edge of SCLK. DOUT goes to a high-impedance state when  $\overline{CS}$  is high. In read data continuous mode (see the *SPI Command Definitions* section for more details), the DOUT output line also indicates when new data are available. Use this feature to minimize the number of connections between the device and the system controller.

Figure 69 shows the data output protocol for ADS1298.

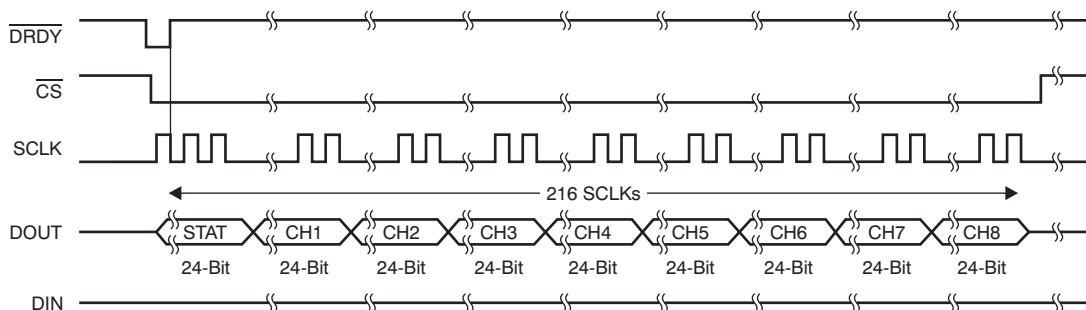

Figure 69. SPI Bus Data Output for the ADS1298 (Eight Channels)

## Programming (continued)

### 9.5.2 SPI Command Definitions

The ADS129x provide flexible configuration control. The opcode commands, summarized in [Table 15](#), control and configure the operation of the ADS129x. The opcode commands are stand-alone, except for the register read and register write operations that require a second command byte plus data.  $\overline{CS}$  can be taken high or held low between opcode commands, but must stay low for the entire command operation (especially for multibyte commands). System opcode commands and the RDATA command are decoded by the ADS129x on the seventh falling edge of SCLK. The register read and write opcodes are decoded on the eighth SCLK falling edge. Be sure to follow SPI timing requirements when pulling  $\overline{CS}$  high after issuing a command.

**Table 15. Opcode Command Definitions**

COMMAND	DESCRIPTION	FIRST BYTE	SECOND BYTE
<b>SYSTEM COMMANDS</b>			
WAKEUP	Wakeup from standby mode	0000 0010 (02h)	—
STANDBY	Enter standby mode	0000 0100 (04h)	—
RESET	Reset the device	0000 0110 (06h)	—
START	Start/restart (synchronize) conversions	0000 1000 (08h)	—
STOP	Stop conversion	0000 1010 (0Ah)	—
<b>DATA READ COMMANDS</b>			
RDATA C	Enable Read Data Continuous mode. This mode is the default mode at power up. <sup>(1)</sup>	0001 0000 (10h)	—
SDATA C	Stop Read Data Continuously mode	0001 0001 (11h)	—
RDATA	Read data by command; supports multiple read back.	0001 0010 (12h)	—
<b>REGISTER READ COMMANDS</b>			
RREG	Read $n$ $nnnn$ registers starting at address $r$ $rrrr$	001 $r$ $rrrr$ (2xh) <sup>(2)</sup>	000 $n$ $nnnn$ <sup>(2)</sup>
WREG	Write $n$ $nnnn$ registers starting at address $r$ $rrrr$	010 $r$ $rrrr$ (4xh) <sup>(2)</sup>	000 $n$ $nnnn$ <sup>(2)</sup>

(1) When in RDATA C mode, the RREG command is ignored.

(2)  $n$   $nnnn$  = number of registers to be read/written – 1. For example, to read/write three registers, set  $n$   $nnnn$  = 0 (0010).  $r$   $rrrr$  = starting register address for read/write opcodes.

#### 9.5.2.1 WAKEUP: Exit Standby Mode

The WAKEUP opcode exits low-power standby mode; see the [STANDBY: Enter Standby Mode](#) section. Time is required when exiting standby mode (see the [Electrical Characteristics](#) for details). *There are no restrictions on the SCLK rate for this command; issue this command at any time. Any subsequent command must be sent after 4  $t_{CLK}$  cycles.*

#### 9.5.2.2 STANDBY: Enter Standby Mode

The STANDBY opcode command enters low-power standby mode. All parts of the circuit are shut down except for the reference section. Standby mode power consumption is specified in the [Electrical Characteristics](#). *There are no restrictions on the SCLK rate for this command; issue this command at any time. Send a WAKEUP command to return device to normal operation. Serial interface is active; therefore, register read and write commands are permitted while in this mode.*

### 9.5.2.3 RESET: Reset Registers to Default Values

The RESET command resets the digital filter cycle and returns all register settings to the respective default values. See the [Reset \(RESET Pin and Reset Command\)](#) section for more details. *There are no restrictions on the SCLK rate for this command; issue this command at any time.* 18  $t_{CLK}$  cycles are required to execute the RESET command. Do not send any commands during this time.

### 9.5.2.4 START: Start Conversions

This opcode starts data conversions. Tie the START pin low to control conversions by command. If conversions are in progress this command has no effect. The STOP opcode command is used to stop conversions. If the START command is immediately followed by a STOP command, there must be a gap of 4  $t_{CLK}$  cycles between the two commands. When the START opcode is sent to the device, keep the START pin low until the STOP command is issued. (See the [Start Mode](#) subsection of the [SPI Interface](#) section for more details.) *There are no restrictions on the SCLK rate for this command and it can be issued any time.*

### 9.5.2.5 STOP: Stop Conversions

The STOP opcode stops conversions. Tie the START pin low to control conversions by command. When the STOP command is sent, the conversion in progress completes and further conversions are stopped. If conversions are already stopped, this command has no effect. *There are no restrictions on the SCLK rate for this command; issue this command at any time.*

### 9.5.2.6 RDATA: Read Data Continuous

The RDATA opcode enables the output of conversion data on each  $\overline{DRDY}$  without the need to issue subsequent read data opcodes. This opcode places the conversion data in the output register where it may be shifted out directly. The read data continuous mode is the default mode of the device and the device defaults to this mode on power up and reset.

RDATA mode is cancelled by the stop read data continuous command (SDATA). If the device is in RDATA mode, an SDATA command must be issued before any other commands can be sent to the device. There is no restriction on the SCLK rate for this command. However, subsequent data retrieval SCLKs or the SDATA opcode command must wait at least 4  $t_{CLK}$  cycles. As shown in [Figure 70](#), the timing for RDATA illustrates the keep-out zone of 4  $t_{CLK}$  periods around the  $\overline{DRDY}$  pulse when this command cannot be issued. If no data are retrieved from the device, DOUT and  $\overline{DRDY}$  behave similarly in this mode. To retrieve data from the device after RDATA command is issued, make sure that either the START pin is high or the START command is issued. [Figure 70](#) shows the recommended way to use the RDATA command. RDATA is ideally suited for applications such as data loggers or recorders, where registers are set once and do not need to be reconfigured.

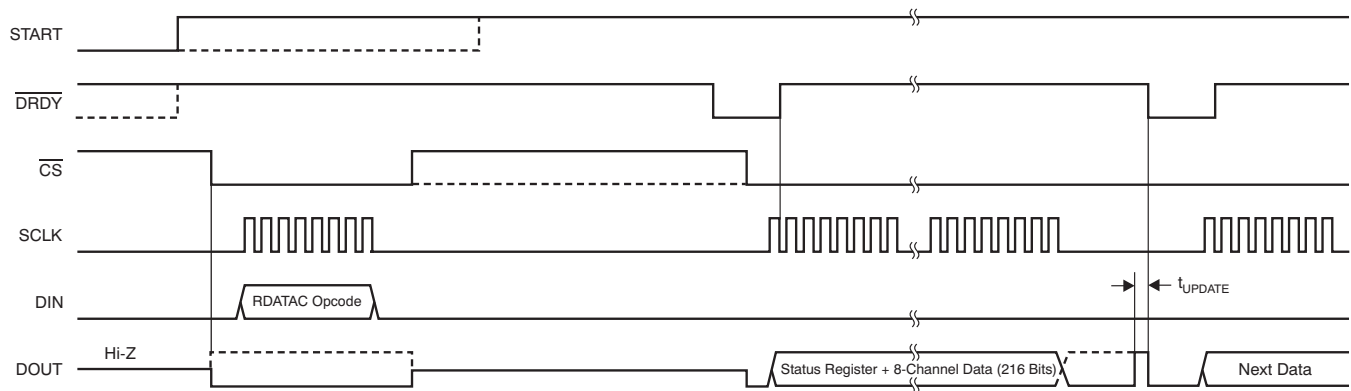

(1)  $t_{UPDATE} = 4 / f_{CLK}$  (where  $f_{CLK} = 1 / t_{CLK}$ ). Do not read data during this time.

**Figure 70. RDATA Usage**

### 9.5.2.7 SDATAC: Stop Read Data Continuous

This SDATAC opcode command cancels read data continuous (RDATAAC) mode. There is no restriction on the SCLK rate for this command, but the next command must wait for 4  $t_{CLK}$  cycles.

### 9.5.2.8 RDATA: Read Data

Issue the RDATA command after  $\overline{DRDY}$  goes low to read the conversion result (in SDATAC mode). There is no restriction on the SCLK rate for this command, and there is no wait time needed for the subsequent commands or data retrieval SCLKs. To retrieve data from the device after RDATA command is issued, make sure that either the START pin is high or the START command is issued. When reading data with the RDATA command, the read operation can overlap the occurrence of the next  $\overline{DRDY}$  without data corruption. Figure 71 shows the recommended way to use the RDATA command. RDATA is best suited for ECG- and EEG-type systems, where register settings must be read or changed often between conversion cycles.

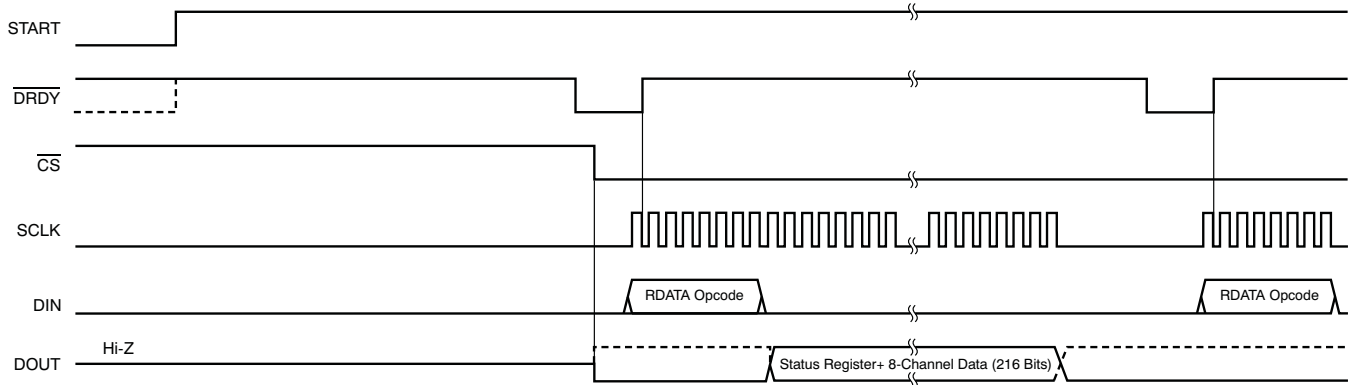

Figure 71. RDATA Usage

### 9.5.2.9 Sending Multibyte Commands

The ADS129x serial interface decodes commands in bytes, and requires 4  $t_{CLK}$  periods to decode and execute. Therefore, when sending multibyte commands, a 4  $t_{CLK}$  period must separate the end of one byte (or opcode) and the next.

For example, if CLK is 2.048 MHz, then  $t_{SDECODE}$  ( $4 \times t_{CLK}$ ) is 1.96  $\mu$ s. When SCLK is 16 MHz, the maximum transfer speed for one byte is 500 ns. This byte transfer time does not meet the  $t_{SDECODE}$  specification; therefore, a delay must be inserted so that the end of the second byte arrives 1.46  $\mu$ s later. However, if SCLK is 4 MHz, one byte is transferred in 2  $\mu$ s. Because this transfer time exceeds the  $t_{SDECODE}$  specification, the processor can send subsequent bytes without delay. In the second scenario, the serial port can be programmed to use multiple-byte transfers instead of the single-byte transfers required to meet the timing of the first scenario.

### 9.5.2.10 RREG: Read From Register

The RREG opcode command reads register data. The RREG command is a two-byte opcode followed by the output of the register data. The first byte contains the command opcode and the register address. The second byte of the opcode specifies the number of registers to read – 1.

First opcode byte: 001r rrrr, where r rrrr is the starting register address.

Second opcode byte: 000n nnnn, where n nnnn is the number of registers to read – 1.

The 17th SCLK rising edge of the operation clocks out the MSB of the first register, as shown in Figure 72. When the device is in read data continuous mode, it is necessary to issue a SDATAC command before a RREG command can be issued. An RREG command can be issued any time. However, because this command is a multibyte command, there are restrictions on the SCLK rate depending on the way the SCLKs are issued. See the [Serial Clock \(SCLK\)](#) section for more details.  $\overline{CS}$  must be low for the entire command.

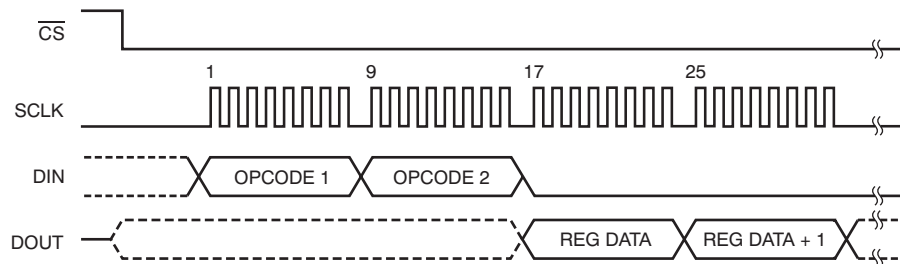

**Figure 72. RREG Command Example: Read Two Registers Starting from Register 00h (ID Register)  
(OPCODE 1 = 0010 0000, OPCODE 2 = 0000 0001)**

### 9.5.2.11 WREG: Write to Register

The WREG opcode command writes register data. The WREG command is a two-byte opcode followed by the input of the register data. The first byte contains the command opcode and the register address. The second byte of the opcode specifies the number of registers to write – 1.

First opcode byte: 010r rrrr, where r rrrr is the starting register address.

Second opcode byte: 000n nnnn, where n nnnn is the number of registers to write – 1.

After the opcode bytes, the register data follows (in MSB-first format), as shown in Figure 73. The WREG command can be issued any time. However, because this command is a multibyte command, there are restrictions on the SCLK rate depending on the way the SCLKs are issued. See the [Serial Clock \(SCLK\)](#) section for more details.  $\overline{CS}$  must be low for the entire command.

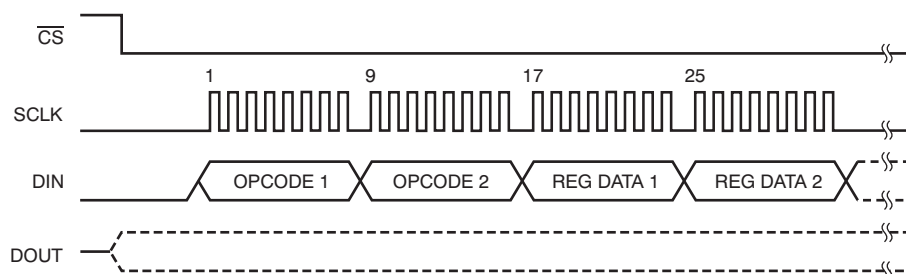

**Figure 73. WREG Command Example: Write Two Registers Starting from 00h (ID Register)  
(OPCODE 1 = 0100 0000, OPCODE 2 = 0000 0001)**

## 9.6 Register Maps

Table 16 lists the various ADS129x registers.

**Table 16. Register Assignments**

ADDRESS	REGISTER	RESET VALUE (Hex)	BIT 7	BIT 6	BIT 5	BIT 4	BIT 3	BIT 2	BIT 1	BIT 0
<b>DEVICE SETTINGS (READ-ONLY REGISTERS)</b>										
00h	ID	xx	DEV_ID7	DEV_ID6	DEV_ID5	1	0	DEV_ID2	DEV_ID1	DEV_ID0
<b>GLOBAL SETTINGS ACROSS CHANNELS</b>										
01h	CONFIG1	06	HR	DAISY_EN	CLK_EN	0	0	DR2	DR1	DR0
02h	CONFIG2	40	0	0	WCT_CHOP	INT_TEST	0	TEST_AMP	TEST_FREQ1	TEST_FREQ0
03h	CONFIG3	40	PD_REFBUF	1	VREF_4V	RLD_MEAS	RLDREF_INT	PD_RLD	RLD_LOFF_SENS	RLD_STAT
04h	LOFF	00	COMP_TH2	COMP_TH1	COMP_TH0	VLEAD_OFF_EN	Ilead_OFF1	Ilead_OFF0	FLEAD_OFF1	FLEAD_OFF0
<b>CHANNEL-SPECIFIC SETTINGS</b>										
05h	CH1SET	00	PD1	GAIN12	GAIN11	GAIN10	0	MUX12	MUX11	MUX10
06h	CH2SET	00	PD2	GAIN22	GAIN21	GAIN20	0	MUX22	MUX21	MUX20
07h	CH3SET	00	PD3	GAIN32	GAIN31	GAIN30	0	MUX32	MUX31	MUX30
08h	CH4SET	00	PD4	GAIN42	GAIN41	GAIN40	0	MUX42	MUX41	MUX40
09h	CH5SET <sup>(1)</sup>	00	PD5	GAIN52	GAIN51	GAIN50	0	MUX52	MUX51	MUX50
0Ah	CH6SET <sup>(1)</sup>	00	PD6	GAIN62	GAIN61	GAIN60	0	MUX62	MUX61	MUX60
0Bh	CH7SET <sup>(1)</sup>	00	PD7	GAIN72	GAIN71	GAIN70	0	MUX72	MUX71	MUX70
0Ch	CH8SET <sup>(1)</sup>	00	PD8	GAIN82	GAIN81	GAIN80	0	MUX82	MUX81	MUX80
0Dh	RLD_SENSP <sup>(2)</sup>	00	RLD8P <sup>(1)</sup>	RLD7P <sup>(1)</sup>	RLD6P <sup>(1)</sup>	RLD5P <sup>(1)</sup>	RLD4P	RLD3P	RLD2P	RLD1P
0Eh	RLD_SENSN <sup>(2)</sup>	00	RLD8N <sup>(1)</sup>	RLD7N <sup>(1)</sup>	RLD6N <sup>(1)</sup>	RLD5N <sup>(1)</sup>	RLD4N	RLD3N	RLD2N	RLD1N
0Fh	LOFF_SENSP <sup>(2)</sup>	00	LOFF8P	LOFF7P	LOFF6P	LOFF5P	LOFF4P	LOFF3P	LOFF2P	LOFF1P
10h	LOFF_SENSN <sup>(2)</sup>	00	LOFF8N	LOFF7N	LOFF6N	LOFF5N	LOFF4N	LOFF3N	LOFF2N	LOFF1N
11h	LOFF_FLIP	00	LOFF_FLIP8	LOFF_FLIP7	LOFF_FLIP6	LOFF_FLIP5	LOFF_FLIP4	LOFF_FLIP3	LOFF_FLIP2	LOFF_FLIP1
<b>LEAD-OFF STATUS REGISTERS (READ-ONLY REGISTERS)</b>										
12h	LOFF_STATP	00	IN8P_OFF	IN7P_OFF	IN6P_OFF	IN5P_OFF	IN4P_OFF	IN3P_OFF	IN2P_OFF	IN1P_OFF
13h	LOFF_STATN	00	IN8N_OFF	IN7N_OFF	IN6N_OFF	IN5N_OFF	IN4N_OFF	IN3N_OFF	IN2N_OFF	IN1N_OFF
<b>GPIO AND OTHER REGISTERS</b>										
14h	GPIO	0F	GPIOD4	GPIOD3	GPIOD2	GPIOD1	GPIOC4	GPIOC3	GPIOC2	GPIOC1
15h	PACE	00	0	0	0	PACEE1	PACEE0	PACEO1	PACEO0	PD_PACE
16h	RESP	00	RESP_DEMOD_EN1	RESP_MOD_EN1	1	RESP_PH2	RESP_PH1	RESP_PH0	RESP_CTRL1	RESP_CTRL0
17h	CONFIG4	00	RESP_FREQ2	RESP_FREQ1	RESP_FREQ0	0	SINGLE_SHOT	WCT_TO_RLD	PD_LOFF_COMP	0
18h	WCT1	00	aVF_CH6	aVL_CH5	aVR_CH7	avR_CH4	PD_WCTA	WCTA2	WCTA1	WCTA0
19h	WCT2	00	PD_WCTC	PD_WCTB	WCTB2	WCTB1	WCTB0	WCTC2	WCTC1	WCTC0

- (1) CH5SET and CH6SET are not available for the ADS1294 and ADS1294R. CH7SET and CH8SET registers are not available for the ADS1294, ADS1294R, ADS1296, and ADS1296R.
- (2) The RLD\_SENSP, PACE\_SENSP, LOFF\_SENSP, LOFF\_SENSN, and LOFF\_FLIP registers bits[5:4] are not available for the ADS1294 and ADS1294R. Bits[7:6] are not available for the ADS1294, ADS1296, ADS1294R, and ADS1296R.

## 9.6.1 Register Descriptions

The read-only ID control register is programmed during device manufacture to indicate device characteristics.

### 9.6.1.1 ID: ID Control Register (address = 00h) (reset = xxh)

**Figure 74. ID Control Register**

7	6	5	4	3	2	1	0
DEV_ID[7:5]			1	0	DEV_ID[2:0]		
R-x			R-2h		R-x		

LEGEND: R/W = Read/Write; R = Read only; -n = value after reset

**Table 17. ID Control Register Field Descriptions**

Bit	Field	Type	Reset	Description
7:5	DEV_ID[7:5]	R	xh	<b>Device ID</b> These bits indicate the device family. 000 = Reserved 011 = Reserved 100 = ADS129x device family 101 = Reserved 110 = ADS129xR device family 111 = Reserved
4:3	RESERVED	R	2h	<b>Reserved</b> Always read back 2h
2:0	DEV_ID[2:0]	R	xh	<b>Channel ID</b> These bits indicates number of channels. 000 = 4-channel ADS1294 or ADS1294R 001 = 6-channel ADS1296 or ADS1296R 010 = 8-channel ADS1298 or ADS1298R 011 = Reserved 111 = Reserved

**9.6.1.2 CONFIG1: Configuration Register 1 (address = 01h) (reset = 06h)**
**Figure 75. CONFIG1: Configuration Register 1**

7	6	5	4	3	2	1	0
HR	$\overline{\text{DAISY\_EN}}$	CLK_EN	0	0	DR[2:0]		
R/W-0h	R/W-0h	R/W-0h	R/W-0h		R/W-6h		

LEGEND: R/W = Read/Write; R = Read only; -n = value after reset

**Table 18. Configuration Register 1 Field Descriptions**

Bit	Field	Type	Reset	Description
7	HR	R/W	0h	<b>High-resolution or low-power mode</b> This bit determines whether the device runs in low-power or high-resolution mode. 0 = LP mode 1 = HR mode
6	$\overline{\text{DAISY\_EN}}$	R/W	0h	<b>Daisy-chain or multiple readback mode</b> This bit determines which mode is enabled. 0 = Daisy-chain mode 1 = Multiple readback mode
5	CLK_EN	R/W	0h	<b>CLK connection<sup>(1)</sup></b> This bit determines if the internal oscillator signal is connected to the CLK pin when the CLKSEL pin = 1. 0 = Oscillator clock output disabled 1 = Oscillator clock output enabled
4:3	RESERVED	R/W	0h	<b>Reserved</b> Always write 0h
2:0	DR[2:0]	R/W	6h	<b>Output data rate</b> For High-Resolution mode, $f_{\text{MOD}} = f_{\text{CLK}} / 4$ . For low power mode, $f_{\text{MOD}} = f_{\text{CLK}} / 8$ . These bits determine the output data rate of the device. 000: $f_{\text{MOD}} / 16$ (HR Mode: 32 kSPS, LP Mode: 16 kSPS) 001: $f_{\text{MOD}} / 32$ (HR Mode: 16 kSPS, LP Mode: 8 kSPS) 010: $f_{\text{MOD}} / 64$ (HR Mode: 8 kSPS, LP Mode: 4 kSPS) 011: $f_{\text{MOD}} / 128$ (HR Mode: 4 kSPS, LP Mode: 2 kSPS) 100: $f_{\text{MOD}} / 256$ (HR Mode: 2 kSPS, LP Mode: 1 kSPS) 101: $f_{\text{MOD}} / 512$ (HR Mode: 1 kSPS, LP Mode: 500 SPS) 110: $f_{\text{MOD}} / 1024$ (HR Mode: 500 SPS, LP Mode: 250 SPS) 111: Reserved (do not use)

(1) Additional power is consumed when driving external devices.

### 9.6.1.3 CONFIG2: Configuration Register 2 (address = 02h) (reset = 40h)

Configuration register 2 configures the test signal generation. See the [Input Multiplexer](#) section for more details.

**Figure 76. CONFIG2: Configuration Register 2**

7	6	5	4	3	2	1	0
0	0	WCT_CHOP	INT_TEST	0	TEST_AMP	TEST_FREQ[1:0]	
R/W-1h		R/W-0h	R/W-0h	R/W-0h	R/W-0h	R/W-0h	

LEGEND: R/W = Read/Write; R = Read only; -n = value after reset

**Table 19. Configuration Register 2 Field Descriptions**

Bit	Field	Type	Reset	Description
7:6	RESERVED	R/W	1h	<b>Reserved</b> Always write 0h
5	WCT_CHOP	R/W	0h	<b>WCT chopping scheme</b> This bit determines whether the chopping frequency of WCT amplifiers is variable or fixed. 0 = Chopping frequency varies, see <a href="#">Table 7</a> 1 = Chopping frequency constant at $f_{MOD} / 16$
4	INT_TEST	R/W	0h	<b>TEST source</b> This bit determines the source for the test signal. 0 = Test signals are driven externally 1 = Test signals are generated internally
3	RESERVED	R/W	0h	<b>Reserved</b> Always write 0h
2	TEST_AMP	R/W	0h	<b>Test signal amplitude</b> These bits determine the calibration signal amplitude. 0 = $1 \times -(V_{REFP} - V_{REFN}) / 2400 \text{ V}$ 1 = $2 \times -(V_{REFP} - V_{REFN}) / 2400 \text{ V}$
1:0	TEST_FREQ[1:0]	R/W	0h	<b>Test signal frequency</b> These bits determine the calibration signal frequency. 00 = Pulsed at $f_{CLK} / 2^{21}$ 01 = Pulsed at $f_{CLK} / 2^{20}$ 10 = Not used 11 = At dc

**9.6.1.4 CONFIG3: Configuration Register 3 (address = 03h) (reset = 40h)**

Configuration register 3 configures multireference and RLD operation.

**Figure 77. CONFIG3: Configuration Register 3**

7	6	5	4	3	2	1	0
PD_REFBUF	1	VREF_4V	RLD_MEAS	RLDREF_INT	PD_RLD	RLD_LOFF_SE NS	RLD_STAT
R/W-0h	R/W-1h	R/W-0h	R/W-0h	R/W-0h	R/W-0h	R/W-0h	R-0h

LEGEND: R/W = Read/Write; R = Read only; -n = value after reset

**Table 20. Configuration Register 3 Field Descriptions**

Bit	Field	Type	Reset	Description
7	PD_REFBUF	R/W	0h	<b>Power-down reference buffer</b> This bit determines the power-down reference buffer state. 0 = Power-down internal reference buffer 1 = Enable internal reference buffer
6	RESERVED	R/W	1h	<b>Reserved</b> Always write 1h
5	VREF_4V	R/W	0h	<b>Reference voltage</b> This bit determines the reference voltage, VREFP. 0 = VREFP is set to 2.4 V 1 = VREFP is set to 4 V (use only with a 5-V analog supply)
4	RLD_MEAS	R/W	0h	<b>RLD measurement</b> This bit enables RLD measurement. The RLD signal may be measured with any channel. 0 = Open 1 = RLD_IN signal is routed to the channel that has the MUX_Setting 010 (V <sub>REF</sub> )
3	RLDREF_INT	R/W	0h	<b>RLDREF signal</b> This bit determines the RLDREF signal source. 0 = RLDREF signal fed externally 1 = RLDREF signal (AVDD – AVSS) / 2 generated internally
2	PD_RLD	R/W	0h	<b>RLD buffer power</b> This bit determines the RLD buffer power state. 0 = RLD buffer is powered down 1 = RLD buffer is enabled
1	RLD_LOFF_SENS	R/W	0h	<b>RLD sense function</b> This bit enables the RLD sense function. 0 = RLD sense is disabled 1 = RLD sense is enabled
0	RLD_STAT	R	0h	<b>RLD lead-off status</b> This bit determines the RLD status. 0 = RLD is connected 1 = RLD is not connected

**9.6.1.5 LOFF: Lead-Off Control Register (address = 04h) (reset = 00h)**

The lead-off control register configures the lead-off detection operation.

**Figure 78. LOFF: Lead-Off Control Register**

7	6	5	4	3	2	1	0
COMP_TH2[2:0]			VLEAD_OFF_EN	ILEAD_OFF[1:0]		FLEAD_OFF[1:0]	
R/W-0h			R/W-0h	R/W-0h		R/W-0h	

LEGEND: R/W = Read/Write; R = Read only; -n = value after reset

**Table 21. Lead-Off Control Register Field Descriptions**

Bit	Field	Type	Reset	Description
7:5	COMP_TH[2:0]	R/W	0h	<b>Lead-off comparator threshold</b> Comparator positive side 000 = 95% 001 = 92.5% 010 = 90% 011 = 87.5% 100 = 85% 101 = 80% 110 = 75% 111 = 70% Comparator negative side 000 = 5% 001 = 7.5% 010 = 10% 011 = 12.5% 100 = 15% 101 = 20% 110 = 25% 111 = 30%
4	VLEAD_OFF_EN	R/W	0h	<b>Lead-off detection mode</b> This bit determines the lead-off detection mode. 0 = Current source mode lead-off 1 = pullup or pulldown resistor mode lead-off
3:2	ILEAD_OFF[1:0]	R/W	0h	<b>Lead-off current magnitude</b> These bits determine the magnitude of current for the current lead-off mode. 00 = 6 nA 01 = 12 nA 10 = 18 nA 11 = 24 nA
1:0	FLEAD_OFF[1:0]	R/W	0h	<b>Lead-off frequency</b> These bits determine the frequency of lead-off detect for each channel. 00 = When any bits of the LOFF_SENSP or LOFF_SENSN registers are turned on, make sure that FLEAD[1:0] are either set to 01 or 11 01 = AC lead-off detection at $f_{DR} / 4$ 10 = Do not use 11 = DC lead-off detection turned on

**9.6.1.6 CHnSET: Individual Channel Settings (n = 1 to 8) (address = 05h to 0Ch) (reset = 00h)**

The CH[1:8]SET control register configures the power mode, PGA gain, and multiplexer settings channels. See the [Input Multiplexer](#) section for details. CH[2:8]SET are similar to CH1SET, corresponding to the respective channels.

**Figure 79. CHnSET: Individual Channel Settings Register**

7	6	5	4	3	2	1	0
PD <sub>n</sub>	GAIN <sub>n</sub> [2:0]			0	MUX <sub>n</sub> [2:0]		
R/W-0h	R/W-0h			R/W-0h	R/W-0h		

LEGEND: R/W = Read/Write; R = Read only; -n = value after reset

**Table 22. Individual Channel Settings (n = 1 to 8) Field Descriptions**

Bit	Field	Type	Reset	Description
7	PD <sub>n</sub>	R/W	0h	<b>Power-down</b> This bit determines the channel power mode for the corresponding channel. 0 = Normal operation 1 = Channel power-down. When powering down a channel, TI recommends that the channel be set to input short by setting the appropriate MUX <sub>n</sub> [2:0] = 001 of the CH <sub>n</sub> SET register.
6:4	GAIN <sub>n</sub> [2:0]	R/W	0h	<b>PGA gain</b> These bits determine the PGA gain setting. 000 = 6 001 = 1 010 = 2 011 = 3 100 = 4 101 = 8 110 = 12
3	RESERVED	R/W	0h	<b>Reserved</b> Always write 0h
2:0	MUX <sub>n</sub> [2:0]	R/W	0h	<b>Channel input</b> These bits determine the channel input selection. 000 = Normal electrode input 001 = Input shorted (for offset or noise measurements) 010 = Used in conjunction with RLD_MEAS bit for RLD measurements. See the <a href="#">Right Leg Drive (RLD) DC Bias Circuit</a> subsection of the <a href="#">ECG-Specific Functions</a> section for more details. 011 = MVDD for supply measurement 100 = Temperature sensor 101 = Test signal 110 = RLD_DRP (positive electrode is the driver) 111 = RLD_DRN (negative electrode is the driver)

**9.6.1.7 RLD\_SENSP: RLD Positive Signal Derivation Register (address = 0Dh) (reset = 00h)**

This register controls the selection of the positive signals from each channel for right leg drive (RLD) derivation. See the [Right Leg Drive \(RLD\) DC Bias Circuit](#) section for details.

Registers bits[5:4] are not available for the ADS1294 or ADS1294R. Bits[7:6] are not available for the ADS1294, ADS1294R, ADS1296, or ADS1296R.

**Figure 80. RLD\_SENSP: RLD Positive Signal Derivation Register**

7	6	5	4	3	2	1	0
RLD8P	RLD7P	RLD6P	RLD5P	RLD4P	RLD3P	RLD2P	RLD1P
R/W-0h	R/W-0h	R/W-0h	R/W-0h	R/W-0h	R/W-0h	R/W-0h	R/W-0h

LEGEND: R/W = Read/Write; R = Read only; -n = value after reset

**Table 23. RLD Positive Signal Derivation Field Descriptions**

Bit	Field	Type	Reset	Description
7	RLD8P	R/W	0h	<b>IN8P to RLD</b> Route channel 8 positive signal into RLD derivation 0: Disabled 1: Enabled
6	RLD7P	R/W	0h	<b>IN7P to RLD</b> Route channel 7 positive signal into RLD derivation 0: Disabled 1: Enabled
5	RLD6P	R/W	0h	<b>IN6P to RLD</b> Route channel 6 positive signal into RLD derivation 0: Disabled 1: Enabled
4	RLD5P	R/W	0h	<b>IN5P to RLD</b> Route channel 5 positive signal into RLD derivation 0: Disabled 1: Enabled
3	RLD4P	R/W	0h	<b>IN4P to RLD</b> Route channel 4 positive signal into RLD derivation 0: Disabled 1: Enabled
2	RLD3P	R/W	0h	<b>IN3P to RLD</b> Route channel 3 positive signal into RLD derivation 0: Disabled 1: Enabled
1	RLD2P	R/W	0h	<b>IN2P to RLD</b> Route channel 2 positive signal into RLD channel 0: Disabled 1: Enabled
0	RLD1P	R/W	0h	<b>IN1P to RLD</b> Route channel 1 positive signal into RLD channel 0: Disabled 1: Enabled

**9.6.1.8 RLD\_SENSN: RLD Negative Signal Derivation Register (address = 0Eh) (reset = 00h)**

This register controls the selection of the negative signals from each channel for right leg drive derivation. See the [Right Leg Drive \(RLD\) DC Bias Circuit](#) section for details.

Registers bits[5:4] are not available for the ADS1294 and ADS1294R. Bits[7:6] are not available for the ADS1294, ADS1294R, ADS1296, or ADS1296R.

**Figure 81. RLD\_SENSN: RLD Negative Signal Derivation Register**

7	6	5	4	3	2	1	0
RLD8N	RLD7N	RLD6N	RLD5N	RLD4N	RLD3N	RLD2N	RLD1N
R/W-0h	R/W-0h	R/W-0h	R/W-0h	R/W-0h	R/W-0h	R/W-0h	R/W-0h

LEGEND: R/W = Read/Write; R = Read only; -n = value after reset

**Table 24. RLD Negative Signal Derivation Field Descriptions**

Bit	Field	Type	Reset	Description
7	RLD8N	R/W	0h	<b>IN8N to RLD</b> Route channel 8 negative signal into RLD derivation 0: Disabled 1: Enabled
6	RLD7N	R/W	0h	<b>IN7N to RLD</b> Route channel 7 negative signal into RLD derivation 0: Disabled 1: Enabled
5	RLD6N	R/W	0h	<b>IN6N to RLD</b> Route channel 6 negative signal into RLD derivation 0: Disabled 1: Enabled
4	RLD5N	R/W	0h	<b>IN5N to RLD</b> Route channel 5 negative signal into RLD derivation 0: Disabled 1: Enabled
3	RLD4N	R/W	0h	<b>IN4N to RLD</b> Route channel 4 negative signal into RLD derivation 0: Disabled 1: Enabled
2	RLD3N	R/W	0h	<b>IN3N to RLD</b> Route channel 3 negative signal into RLD derivation 0: Disabled 1: Enabled
1	RLD2N	R/W	0h	<b>IN2N to RLD</b> Route channel 2 negative signal into RLD derivation 0: Disabled 1: Enabled
0	RLD1N	R/W	0h	<b>IN1N to RLD</b> Route channel 1 negative signal into RLD derivation 0: Disabled 1: Enabled

**9.6.1.9 LOFF\_SENSP: Positive Signal Lead-Off Detection Register (address = 0Fh) (reset = 00h)**

This register selects the positive side from each channel for lead-off detection. See the [Lead-Off Detection](#) section for details. The LOFF\_STATP register bits are only valid if the corresponding LOFF\_SENSP bits are set to 1.

Registers bits[5:4] are not available for the ADS1294 or ADS1294R. Bits[7:6] are not available for the ADS1294, ADS1294R, ADS1296, or ADS1296R.

**Figure 82. LOFF\_SENSP: Positive Signal Lead-Off Detection Register**

7	6	5	4	3	2	1	0
LOFF8P	LOFF7P	LOFF6P	LOFF5P	LOFF4P	LOFF3P	LOFF2P	LOFF1P
R/W-0h	R/W-0h	R/W-0h	R/W-0h	R/W-0h	R/W-0h	R/W-0h	R/W-0h

LEGEND: R/W = Read/Write; R = Read only; -n = value after reset

**Table 25. Positive Signal Lead-Off Detection Field Descriptions**

Bit	Field	Type	Reset	Description
7	LOFF8P	R/W	0h	<b>IN8P lead off</b> Enable lead-off detection on IN8P 0: Disabled 1: Enabled
6	LOFF7P	R/W	0h	<b>IN7P lead off</b> Enable lead-off detection on IN7P 0: Disabled 1: Enabled
5	LOFF6P	R/W	0h	<b>IN6P lead off</b> Enable lead-off detection on IN6P 0: Disabled 1: Enabled
4	LOFF5P	R/W	0h	<b>IN5P lead off</b> Enable lead-off detection on IN5P 0: Disabled 1: Enabled
3	LOFF4P	R/W	0h	<b>IN4P lead off</b> Enable lead-off detection on IN4P 0: Disabled 1: Enabled
2	LOFF3P	R/W	0h	<b>IN3P lead off</b> Enable lead-off detection on IN3P 0: Disabled 1: Enabled
1	LOFF2P	R/W	0h	<b>IN2P lead off</b> Enable lead-off detection on IN2P 0: Disabled 1: Enabled
0	LOFF1P	R/W	0h	<b>IN1P lead off</b> Enable lead-off detection on IN1P 0: Disabled 1: Enabled

**9.6.1.10 LOFF\_SENSN: Negative Signal Lead-Off Detection Register (address = 10h) (reset = 00h)**

This register selects the negative side from each channel for lead-off detection. See the [Lead-Off Detection](#) section for details. The LOFF\_STATN register bits are only valid if the corresponding LOFF\_SENSN bits are set to 1.

Registers bits[5:4] are not available for the ADS1294 or ADS1294R. Bits[7:6] are not available for the ADS1294, ADS1294R, ADS1296, or ADS1296R.

**Figure 83. LOFF\_SENSN: Negative Signal Lead-Off Detection Register**

7	6	5	4	3	2	1	0
LOFF8N	LOFF7N	LOFF6N	LOFF5N	LOFF4N	LOFF3N	LOFF2N	LOFF1N
R/W-0h	R/W-0h	R/W-0h	R/W-0h	R/W-0h	R/W-0h	R/W-0h	R/W-0h

LEGEND: R/W = Read/Write; R = Read only; -n = value after reset

**Table 26. Negative Signal Lead-Off Detection Field Descriptions**

Bit	Field	Type	Reset	Description
7	LOFF8N	R/W	0h	<b>IN8N lead off</b> Enable lead-off detection on IN8N 0: Disabled 1: Enabled
6	LOFF7N	R/W	0h	<b>IN7N lead off</b> Enable lead-off detection on IN7N 0: Disabled 1: Enabled
5	LOFF6N	R/W	0h	<b>IN6N lead off</b> Enable lead-off detection on IN6N 0: Disabled 1: Enabled
4	LOFF5N	R/W	0h	<b>IN5N lead off</b> Enable lead-off detection on IN5N 0: Disabled 1: Enabled
3	LOFF4N	R/W	0h	<b>IN4N lead off</b> Enable lead-off detection on IN4N 0: Disabled 1: Enabled
2	LOFF3N	R/W	0h	<b>IN3N lead off</b> Enable lead-off detection on IN3N 0: Disabled 1: Enabled
1	LOFF2N	R/W	0h	<b>IN2N lead off</b> Enable lead-off detection on IN2N 0: Disabled 1: Enabled
0	LOFF1N	R/W	0h	<b>IN1N lead off</b> Enable lead-off detection on IN1N 0: Disabled 1: Enabled

**9.6.1.11 LOFF\_FLIP: Lead-Off Flip Register (address = 11h) (reset = 00h)**

This register controls the direction of the current used for lead-off derivation. See the [Lead-Off Detection](#) section for details.

**Figure 84. LOFF\_FLIP: Lead-Off Flip Register**

7	6	5	4	3	2	1	0
LOFF_FLIP8	LOFF_FLIP7	LOFF_FLIP6	LOFF_FLIP5	LOFF_FLIP4	LOFF_FLIP3	LOFF_FLIP2	LOFF_FLIP1
R/W-0h	R/W-0h	R/W-0h	R/W-0h	R/W-0h	R/W-0h	R/W-0h	R/W-0h

LEGEND: R/W = Read/Write; R = Read only; -n = value after reset

**Table 27. Lead-Off Flip Register Field Descriptions**

Bit	Field	Type	Reset	Description
7	LOFF_FLIP8	R/W	0h	<b>Channel 8 LOFF polarity flip</b> Flip the pullup/pulldown polarity of the current source or resistor on channel 8 for lead-off derivation. 0: No Flip: IN8P is pulled to AVDD and IN8N pulled to AVSS 1: Flipped: IN8P is pulled to AVSS and IN8N pulled to AVDD
6	LOFF_FLIP7	R/W	0h	<b>Channel 7 LOFF polarity flip</b> Flip the pullup/pulldown polarity of the current source or resistor on channel 7 for lead-off derivation. 0: No Flip: IN7P is pulled to AVDD and IN7N pulled to AVSS 1: Flipped: IN7P is pulled to AVSS and IN7N pulled to AVDD
5	LOFF_FLIP6	R/W	0h	<b>Channel 6 LOFF polarity flip</b> Flip the pullup/pulldown polarity of the current source or resistor on channel 6 for lead-off derivation. 0: No Flip: IN6P is pulled to AVDD and IN6N pulled to AVSS 1: Flipped: IN6P is pulled to AVSS and IN6N pulled to AVDD
4	LOFF_FLIP5	R/W	0h	<b>Channel 5 LOFF polarity flip</b> Flip the pullup/pulldown polarity of the current source or resistor on channel 5 for lead-off derivation. 0: No Flip: IN5P is pulled to AVDD and IN5N pulled to AVSS 1: Flipped: IN5P is pulled to AVSS and IN5N pulled to AVDD
3	LOFF_FLIP4	R/W	0h	<b>Channel 4 LOFF polarity flip</b> Flip the pullup/pulldown polarity of the current source or resistor on channel 4 for lead-off derivation. 0: No Flip: IN4P is pulled to AVDD and IN4N pulled to AVSS 1: Flipped: IN4P is pulled to AVSS and IN4N pulled to AVDD
2	LOFF_FLIP3	R/W	0h	<b>Channel 3 LOFF polarity flip</b> Flip the pullup/pulldown polarity of the current source or resistor on channel 3 for lead-off derivation. 0: No Flip: IN3P is pulled to AVDD and IN3N pulled to AVSS 1: Flipped: IN3P is pulled to AVSS and IN3N pulled to AVDD
1	LOFF_FLIP2	R/W	0h	<b>Channel 2 LOFF Polarity Flip</b> Flip the pullup/pulldown polarity of the current source or resistor on channel 2 for lead-off derivation. 0: No Flip: IN2P is pulled to AVDD and IN2N pulled to AVSS 1: Flipped: IN2P is pulled to AVSS and IN2N pulled to AVDD
0	LOFF_FLIP1	R/W	0h	<b>Channel 1 LOFF Polarity Flip</b> Flip the pullup/pulldown polarity of the current source or resistor on channel 1 for lead-off derivation. 0: No Flip: IN1P is pulled to AVDD and IN1N pulled to AVSS 1: Flipped: IN1P is pulled to AVSS and IN1N pulled to AVDD

**9.6.1.12 LOFF\_STATP: Lead-Off Positive Signal Status Register (address = 12h) (reset = 00h)**

This register stores the status of whether the positive electrode on each channel is on or off. See the [Lead-Off Detection](#) section for details. Ignore the LOFF\_STATP values if the corresponding LOFF\_SENSP bits are not set to 1.

When the LOFF\_SENSEP bits are 0, the LOFF\_STATP bits should be ignored.

**Figure 85. LOFF\_STATP: Lead-Off Positive Signal Status Register (Read-Only)**

7	6	5	4	3	2	1	0
IN8P_OFF	IN7P_OFF	IN6P_OFF	IN5P_OFF	IN4P_OFF	IN3P_OFF	IN2P_OFF	IN1P_OFF
R-0h	R-0h	R-0h	R-0h	R-0h	R-0h	R-0h	R-0h

LEGEND: R/W = Read/Write; R = Read only; -n = value after reset

**Table 28. Lead-Off Positive Signal Status Field Descriptions**

Bit	Field	Type	Reset	Description
7	IN8P_OFF	R	0h	<b>Channel 8 positive channel lead-off status</b> Status of whether IN8P electrode is on or off 0: Electrode is on 1: Electrode is off
6	IN7P_OFF	R	0h	<b>Channel 7 positive channel lead-off status</b> Status of whether IN7P electrode is on or off 0: Electrode is on 1: Electrode is off
5	IN6P_OFF	R	0h	<b>Channel 6 positive channel lead-off status</b> Status of whether IN6P electrode is on or off 0: Electrode is on 1: Electrode is off
4	IN5P_OFF	R	0h	<b>Channel 5 positive channel lead-off status</b> Status of whether IN5P electrode is on or off 0: Electrode is on 1: Electrode is off
3	IN4P_OFF	R	0h	<b>Channel 4 positive channel lead-off status</b> Status of whether IN4P electrode is on or off 0: Electrode is on 1: Electrode is off
2	IN3P_OFF	R	0h	<b>Channel 3 positive channel lead-off status</b> Status of whether IN3P electrode is on or off 0: Electrode is on 1: Electrode is off
1	IN2P_OFF	R	0h	<b>Channel 2 positive channel lead-off status</b> Status of whether IN2P electrode is on or off 0: Electrode is on 1: Electrode is off
0	IN1P_OFF	R	0h	<b>Channel 1 positive channel lead-off status</b> Status of whether IN1P electrode is on or off 0: Electrode is on 1: Electrode is off

**9.6.1.13 LOFF\_STATN: Lead-Off Negative Signal Status Register (address = 13h) (reset = 00h)**

This register stores the status of whether the negative electrode on each channel is on or off. See the [Lead-Off Detection](#) section for details. Ignore the LOFF\_STATN values if the corresponding LOFF\_SENSN bits are not set to 1.

When the LOFF\_SENSEN bits are 0, the LOFF\_STATP bits should be ignored.

**Figure 86. LOFF\_STATN: Lead-Off Negative Signal Status Register (Read-Only)**

7	6	5	4	3	2	1	0
IN8N_OFF	IN7N_OFF	IN6N_OFF	IN5N_OFF	IN4N_OFF	IN3N_OFF	IN2N_OFF	IN1N_OFF
R-0h	R-0h	R-0h	R-0h	R-0h	R-0h	R-0h	R-0h

LEGEND: R/W = Read/Write; R = Read only; -n = value after reset

**Table 29. Lead-Off Negative Signal Status Field Descriptions**

Bit	Field	Type	Reset	Description
7	IN8N_OFF	R	0h	<b>Channel 8 negative channel lead-off status</b> Status of whether IN8N electrode is on or off 0: Electrode is on 1: Electrode is off
6	IN7N_OFF	R	0h	<b>Channel 7 negative channel lead-off status</b> Status of whether IN7N electrode is on or off 0: Electrode is on 1: Electrode is off
5	IN6N_OFF	R	0h	<b>Channel 6 negative channel lead-off status</b> Status of whether IN6N electrode is on or off 0: Electrode is on 1: Electrode is off
4	IN5N_OFF	R	0h	<b>Channel 5 negative channel lead-off status</b> Status of whether IN5N electrode is on or off 0: Electrode is on 1: Electrode is off
3	IN4N_OFF	R	0h	<b>Channel 4 negative channel lead-off status</b> Status of whether IN4N electrode is on or off 0: Electrode is on 1: Electrode is off
2	IN3N_OFF	R	0h	<b>Channel 3 negative channel lead-off status</b> Status of whether IN3N electrode is on or off 0: Electrode is on 1: Electrode is off
1	IN2N_OFF	R	0h	<b>Channel 2 negative channel lead-off status</b> Status of whether IN2N electrode is on or off 0: Electrode is on 1: Electrode is off
0	IN1N_OFF	R	0h	<b>Channel 1 negative channel lead-off status</b> Status of whether IN1N electrode is on or off 0: Electrode is on 1: Electrode is off

### 9.6.1.14 GPIO: General-Purpose I/O Register (address = 14h) (reset = 0Fh)

The general-purpose I/O register controls the action of the three GPIO pins. When RESP\_CTRL[1:0] is in mode 01 and 11, the GPIO2, GPIO3, and GPIO4 pins are not available for use.

**Figure 87. GPIO: General-Purpose I/O Register**

7	6	5	4	3	2	1	0
GPIOD[4:1]				GPIOC[4:1]			
R/W-0h				R/W-Fh			

LEGEND: R/W = Read/Write; R = Read only; -n = value after reset

**Table 30. General-Purpose I/O Field Descriptions**

Bit	Field	Type	Reset	Description
7:4	GPIOD[4:1]	R/W	0h	<b>GPIO data</b> These bits are used to read and write data to the GPIO ports. When reading the register, the data returned correspond to the state of the GPIO external pins, whether they are programmed as inputs or as outputs. As outputs, a write to the GPIOD sets the output value. As inputs, a write to the GPIOD has no effect. GPIO is not available in certain respiration modes.
3:0	GPIOC[4:1]	R/W	Fh	<b>GPIO control (corresponding GPIOD)</b> These bits determine if the corresponding GPIOD pin is an input or output. 0 = Output 1 = Input

### 9.6.1.15 PACE: Pace Detect Register (address = 15h) (reset = 00h)

This register provides the pace controls that configure the channel signal used to feed the external pace detect circuitry. See the [Pace Detect](#) section for details.

**Figure 88. PACE: Pace Detect Register**

7	6	5	4	3	2	1	0
0	0	0	PACEE[1:0]		PACEO[1:0]		PD_PACE
R/W-0h	R/W-0h	R/W-0h	R/W-0h		R/W-0h		R/W-0h

LEGEND: R/W = Read/Write; R = Read only; -n = value after reset

**Table 31. (For example, CONTROL\_REVISION Register) Field Descriptions**

Bit	Field	Type	Reset	Description
7:5	RESERVED	R/W	0h	<b>Reserved</b> Always write 0h
4:3	PACEE[1:0]	R/W	0h	<b>Pace even channels</b> These bits control the selection of the even number channels available on TEST_PACE_OUT1. Only one channel may be selected at any time. 00 = Channel 2 01 = Channel 4 10 = Channel 6 (ADS1296, ADS1296R, ADS1298, ADS1298R) 11 = Channel 8 (ADS1298 and ADS1298R)
2:1	PACEO[1:0]	R/W	0h	<b>Pace odd channels</b> These bits control the selection of the odd number channels available on TEST_PACE_OUT2. Only one channel may be selected at any time. 00 = Channel 1 01 = Channel 3 10 = Channel 5 (ADS1296, ADS1296R, ADS1298, ADS1298R) 11 = Channel 7 (ADS1298, ADS1298R)
0	PD_PACE	R/W	0h	<b>Pace detect buffer</b> This bit is used to enable/disable the pace detect buffer. 0 = Pace detect buffer turned off 1 = Pace detect buffer turned on

**9.6.1.16 RESP: Respiration Control Register (address = 16h) (reset = 00h)**

This register provides the controls for the respiration circuitry; see the [Respiration](#) section for details.

**Figure 89. RESP: Respiration Control Register**

7	6	5	4	3	2	1	0
RESP_DEMOD_EN1	RESP_MOD_EN1	1	RESP_PH[2:0]		RESP_CTRL[1:0]		
R/W-0h	R/W-0h	R/W-0h	R/W-0h		R/W-0h		

LEGEND: R/W = Read/Write; R = Read only; -n = value after reset

**Table 32. Respiration Control Register Field Descriptions**

Bit	Field	Type	Reset	Description
7	RESP_DEMOD_EN1	R/W	0h	<b>Enables respiration demodulation circuitry (ADS129xR only; for ADS129x always write 0)</b> This bit enables and disables the demodulation circuitry on channel 1. 0 = RESP demodulation circuitry turned off 1 = RESP demodulation circuitry turned on
6	RESP_MOD_EN1	R/W	0h	<b>RESP_MOD_EN1: Enables respiration modulation circuitry (ADS129xR only; for ADS129x always write 0)</b> This bit enables and disables the modulation circuitry on channel 1. 0 = RESP modulation circuitry turned off 1 = RESP modulation circuitry turned on
5	RESERVED	R/W	0h	<b>Reserved</b> Always write 1h
4:2	RESP_PH[2:0]	R/W	0h	<b>Respiration phase<sup>(1)</sup></b> 000 = 22.5° 001 = 45° 010 = 67.5° 011 = 90° 100 = 112.5° 101 = 135° 110 = 157.5° 111 = N/A
1:0	RESP_CTRL[1:0]	R/W	0h	<b>Respiration control</b> These bits set the mode of the respiration circuitry. 00 = No respiration 01 = External respiration 10 = Internal respiration with internal signals 11 = Internal respiration with user-generated signals

(1) RESP\_PH[2:0] phase control bits only for internal respiration (RESP\_CTRL = 10) and external respiration (RESP\_CTRL = 01) modes when the CONFIG4.RESP\_FREQ[2:0] register bits are 000b or 001b.

**9.6.1.17 CONFIG4: Configuration Register 4 (address = 17h) (reset = 00h)**
**Figure 90. CONFIG4: Configuration Register 4**

7	6	5	4	3	2	1	0
RESP_FREQ[2:0]			0	SINGLE_SHOT	WCT_TO_RLD	PD_LOFF_CO MP	0
R/W-0h			R/W-0h	R/W-0h	R/W-0h	R/W-0h	R/W-0h

LEGEND: R/W = Read/Write; R = Read only; -n = value after reset

**Table 33. Configuration Register 4 Field Descriptions**

Bit	Field	Type	Reset	Description
7:5	RESP_FREQ[2:0]	R/W	0h	<b>Respiration modulation frequency</b> These bits control the respiration control frequency when RESP_CTRL[1:0] = 10 or RESP_CTRL[1:0] = 10 <sup>(1)</sup> . 000 = 64 kHz modulation clock 001 = 32 kHz modulation clock 010 = 16kHz square wave on GPIO3 and GPIO04. Output on GPIO4 is 180 degree out of phase with GPIO3. 011 = 8kHz square wave on GPIO3 and GPIO04. Output on GPIO4 is 180 degree out of phase with GPIO3. 100 = 4kHz square wave on GPIO3 and GPIO04. Output on GPIO4 is 180 degree out of phase with GPIO3. 101 = 2kHz square wave on GPIO3 and GPIO04. Output on GPIO4 is 180 degree out of phase with GPIO3. 110 = 1kHz square wave on GPIO3 and GPIO04. Output on GPIO4 is 180 degree out of phase with GPIO3. 111 = 500Hz square wave on GPIO3 and GPIO04. Output on GPIO4 is 180 degree out of phase with GPIO3. Modes 000 and 001 are modulation frequencies in internal and external respiration modes. In internal respiration mode, the control signals appear at the RESP_MODP and RESP_MODN terminals. All other bit settings generate square waves as described above on GPIO4 and GPIO3.
4	RESERVED	R/W	0h	<b>Reserved</b> Always write 0h
3	SINGLE_SHOT	R/W	0h	<b>Single-shot conversion</b> This bit sets the conversion mode. 0 = Continuous conversion mode 1 = Single-shot mode
2	WCT_TO_RLD	R/W	0h	<b>Connects the WCT to the RLD</b> This bit connects WCT to RLD. 0 = WCT to RLD connection off 1 = WCT to RLD connection on
1	PD_LOFF_COMP	R/W	0h	<b>Lead-off comparator power-down</b> This bit powers down the lead-off comparators. 0 = Lead-off comparators disabled 1 = Lead-off comparators enabled
0	RESERVED	R/W	0h	<b>Reserved</b> Always write 0h

(1) These frequencies assume  $f_{CLK} = 2.048$  MHz.

**9.6.1.18 WCT1: Wilson Central Terminal and Augmented Lead Control Register (address = 18h) (reset = 00h)**

The WCT1 control register configures the device WCT circuit channel selection and the augmented leads.

**Figure 91. WCT1: Wilson Central Terminal and Augmented Lead Control Register**

7	6	5	4	3	2	1	0
aVF_CH6	aVL_CH5	aVR_CH7	aVR_CH4	PD_WCTA	WCTA[2:0]		
R/W-0h	R/W-0h	R/W-0h	R/W-0h	R/W-0h	R/W-0h		

LEGEND: R/W = Read/Write; R = Read only; -n = value after reset

**Table 34. Wilson Central Terminal and Augmented Lead Control Field Descriptions**

Bit	Field	Type	Reset	Description
7	aVF_CH6	R/W	0h	<b>Enable (WCTA + WCTB)/2 to the negative input of channel 6 (ADS1296, ADS1296R, ADS1298, and ADS1298R)</b> 0 = Disabled 1 = Enabled
6	aVL_CH5	R/W	0h	<b>Enable (WCTA + WCTC)/2 to the negative input of channel 5 (ADS1296, ADS1296R, ADS1298, and ADS1298R)</b> 0 = Disabled 1 = Enabled
5	aVR_CH7	R/W	0h	<b>Enable (WCTB + WCTC)/2 to the negative input of channel 7 (ADS1298 and ADS1298R)</b> 0 = Disabled 1 = Enabled
4	aVR_CH4	R/W	0h	<b>Enable (WCTB + WCTC)/2 to the negative input of channel 4</b> 0 = Disabled 1 = Enabled
3	PD_WCTA	R/W	0h	<b>Power-down WCTA</b> 0 = Powered down 1 = Powered on
2:0	WCTA[2:0]	R/W	0h	<b>WCT Amplifier A channel selection, typically connected to RA electrode</b> These bits select one of the eight electrode inputs of channels 1 to 4. 000 = Channel 1 positive input connected to WCTA amplifier 001 = Channel 1 negative input connected to WCTA amplifier 010 = Channel 2 positive input connected to WCTA amplifier 011 = Channel 2 negative input connected to WCTA amplifier 100 = Channel 3 positive input connected to WCTA amplifier 101 = Channel 3 negative input connected to WCTA amplifier 110 = Channel 4 positive input connected to WCTA amplifier 111 = Channel 4 negative input connected to WCTA amplifier

**9.6.1.19 WCT2: Wilson Central Terminal Control Register (address = 18h) (reset = 00h)**

The WCT2 configuration register configures the device WCT circuit channel selection.

**Figure 92. WCT2: Wilson Central Terminal Control Register**

7	6	5	4	3	2	1	0
PD_WCTC	PD_WCTB	WCTB[2:0]		WCTC[2:0]			
R/W-0h	R/W-0h	R/W-0h		R/W-0h			

LEGEND: R/W = Read/Write; R = Read only; -n = value after reset

**Table 35. Wilson Central Terminal Control Field Descriptions**

Bit	Field	Type	Reset	Description
7	PD_WCTC	R/W	0h	<b>Power-down WCTC</b> 0 = Powered down 1 = Powered on
6	PD_WCTB	R/W	0h	<b>Power-down WCTB</b> 0 = Powered down 1 = Powered on
5:3	WCTB[2:0]	R/W	0h	<b>WCT amplifier B channel selection, typically connected to LA electrode.</b> These bits select one of the eight electrode inputs of channels 1 to 4. 000 = Channel 1 positive input connected to WCTB amplifier 001 = Channel 1 negative input connected to WCTB amplifier 010 = Channel 2 positive input connected to WCTB amplifier 011 = Channel 2 negative input connected to WCTB amplifier 100 = Channel 3 positive input connected to WCTB amplifier 101 = Channel 3 negative input connected to WCTB amplifier 110 = Channel 4 positive input connected to WCTB amplifier 111 = Channel 4 negative input connected to WCTB amplifier
2:0	WCTC[2:0]	R/W	0h	<b>WCT amplifier C channel selection, typically connected to LL electrode.</b> These bits select one of the eight electrode inputs of channels 1 to 4. 000 = Channel 1 positive input connected to WCTC amplifier 001 = Channel 1 negative input connected to WCTC amplifier 010 = Channel 2 positive input connected to WCTC amplifier 011 = Channel 2 negative input connected to WCTC amplifier 100 = Channel 3 positive input connected to WCTC amplifier 101 = Channel 3 negative input connected to WCTC amplifier 110 = Channel 4 positive input connected to WCTC amplifier 111 = Channel 4 negative input connected to WCTC amplifier

## 10 Application and Implementation

---

### NOTE

Information in the following applications sections is not part of the TI component specification, and TI does not warrant its accuracy or completeness. TI's customers are responsible for determining suitability of components for their purposes. Customers should validate and test their design implementation to confirm system functionality.

---

### 10.1 Application Information

#### 10.1.1 Setting the Device for Basic Data Capture

[Figure 93](#) outlines the procedure to configure the device in a basic state and capture data. This procedure puts the device into a configuration that matches the parameters listed in the [Specifications](#) section, in order to check if the device is working properly in the user system. Follow this procedure initially until familiar with the device settings. After this procedure has been verified, the device can be configured as needed. For details on the timings for commands, refer to the appropriate sections in the data sheet. Sample programming codes are added for the ECG-specific functions.

**Application Information (continued)**

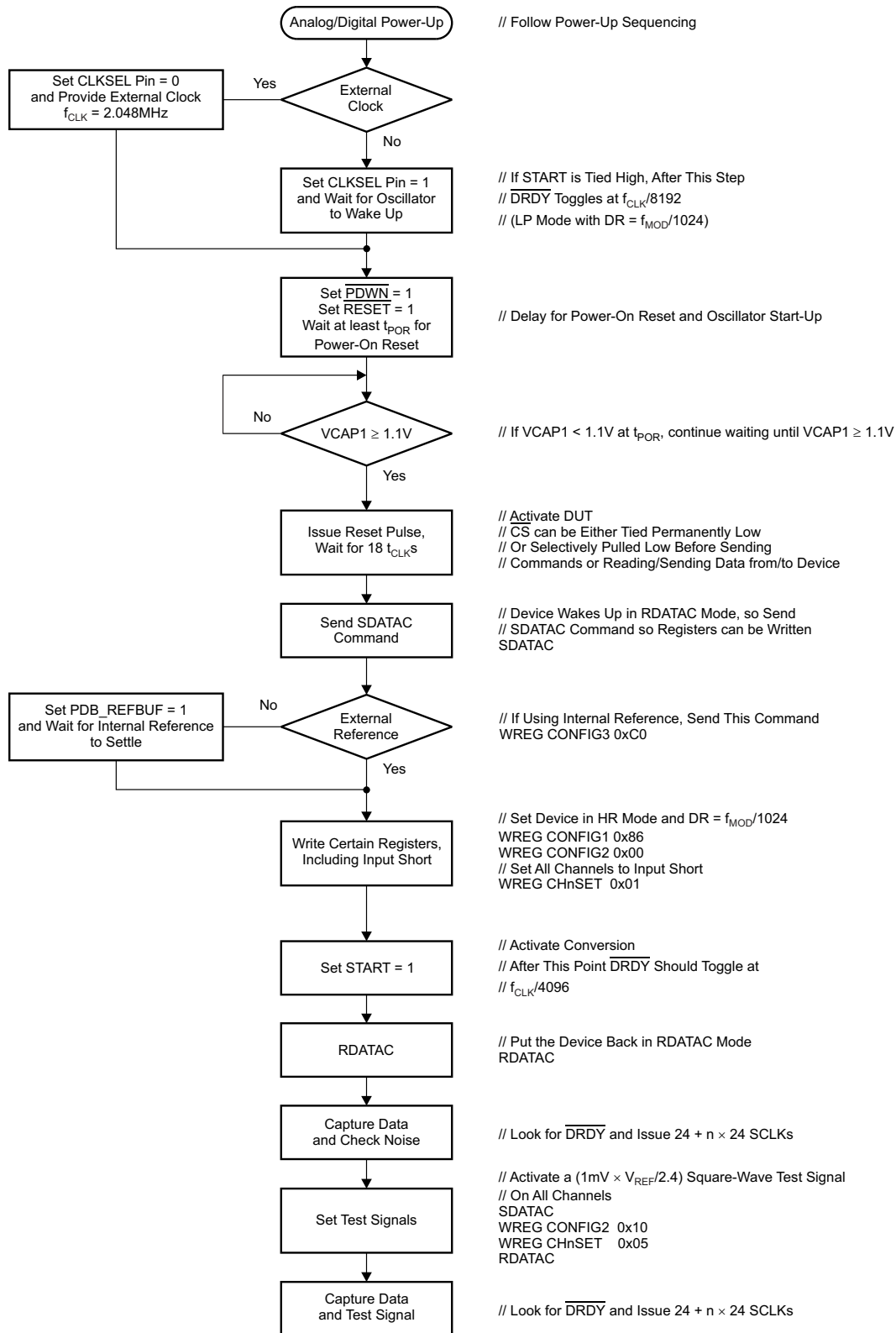

**Figure 93. Initial Flow at Power Up**

## Application Information (continued)

### 10.1.1.1 Lead-Off

Sample code to set dc lead-off with pullup or pulldown resistors on all channels:

```
WREG LOFF 0x13          // Comparator threshold at 95% and 5%, pullup or pulldown resistor
                        // dc lead-off
WREG CONFIG4 0x02      // Turn on dc lead-off comparators
WREG LOFF_SENSP 0xFF   // Turn on the P-side of all channels for lead-off sensing
WREG LOFF_SENSN 0xFF   // Turn on the N-side of all channels for lead-off sensing
```

Observe the status bits of the output data stream to monitor lead-off status.

### 10.1.1.2 Right Leg Drive

Sample code to choose RLD as an average of the first three channels.

```
WREG RLD_SENSP 0x07    // Select channel 1-3 P-side for RLD sensing
WREG RLD_SENSN 0x07    // Select channel 1-3 N-side for RLD sensing
WREG CONFIG3 b'xlxx 1100 // Turn on RLD amplifier, set internal RLDREF voltage
```

Sample code to route the RLD\_OUT signal through channel 4 N-side and measure RLD with channel 5. Make sure the external side to the chip RLDOUT is connected to RLDIN.

```
WREG CONFIG3 b'xxxx1 1100 // Turn on RLD amp, set internal RLDREF voltage, set RLD measurement bit
WREG CH4SET b'lxxx 0111 // Route RLDIN to channel 4 N-side
WREG CH5SET b'lxxx 0010 // Route RLDIN to be measured at channel 5 w.r.t RLDREF
```

### 10.1.1.3 Pace Detection

Sample code to select channel 5 and 6 outputs for pace:

```
WREG PACE b'0001 0101 // Power-up pace amplifier and select channel 5 and 6 for pace out
```

## 10.1.2 Establishing the Input Common-Mode

The ADS129x measures fully-differential signals where the common-mode voltage point is the midpoint of the positive and negative analog input. The internal PGA restricts the common-mode input range because of the headroom required for operation. The human body is prone to common-mode drifts because noise easily couples onto the human body, similar to an antenna. These common-mode drifts may push the ADS129x input common-mode voltage out of the measurable range of the ADC.

If a patient-drive electrode is used by the system, the ADS129x includes an on-chip right leg drive (RLD) amplifier that connects to the patient drive electrode. The RLD amplifier function is to bias the patient to maintain the other electrode common-mode voltages within the valid range. When powered on, the amplifier uses either the analog midsupply voltage, or the voltage present at the RLDREF pin, as a reference input to stabilize the output near that voltage.

### Application Information (continued)

The ADS129x provide the option to use input electrode voltages as feedback to the amplifier to more effectively stabilize the output to the amplifier reference voltage by setting corresponding bits in the RLD\_SENSP and RLD\_SENSN registers. See to [Figure 94](#) for an example of a three-electrode system that leverages this technique.

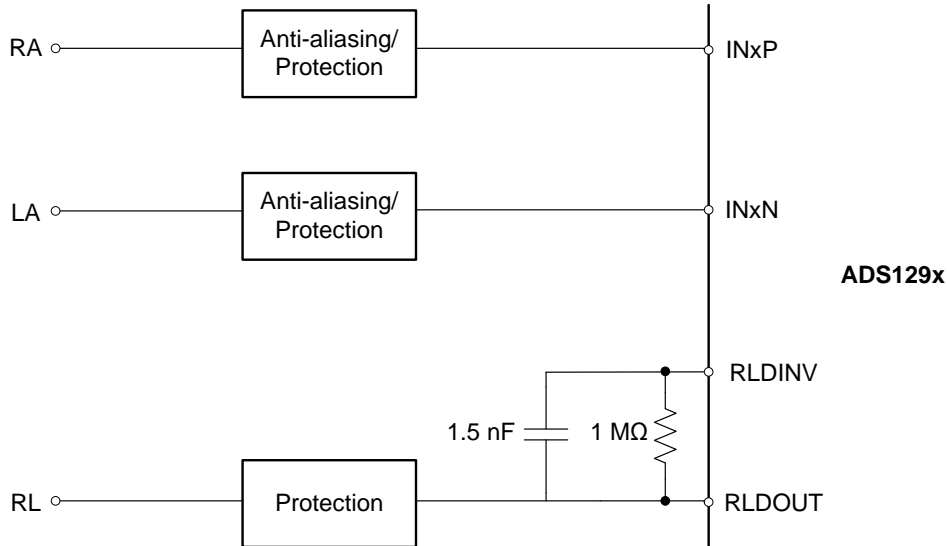

**Figure 94. Setting Common-Mode Using RLD Electrode**

A second strategy for maintaining a valid common-mode voltage is to ac-couple the analog inputs, which is especially useful when a patient-drive electrode is not in use. A dc blocking capacitor combined with a voltage divider between the analog power supplies, or a pullup resistor to set the DC bias to a known point, effectively makes sure that the dc common-mode voltage never drifts. Applications that do not use a patient-drive electrode may still use the RLD amplifier on the ADS129x as a buffered midsupply voltage to bias the inputs. Take care when choosing the passive components because the capacitor and the resistors form an RC high-pass filter. If passive components are chosen poorly, the filter undesirably attenuates frequencies at the lower end of the signal band. [Figure 95](#) shows an example of this configuration.

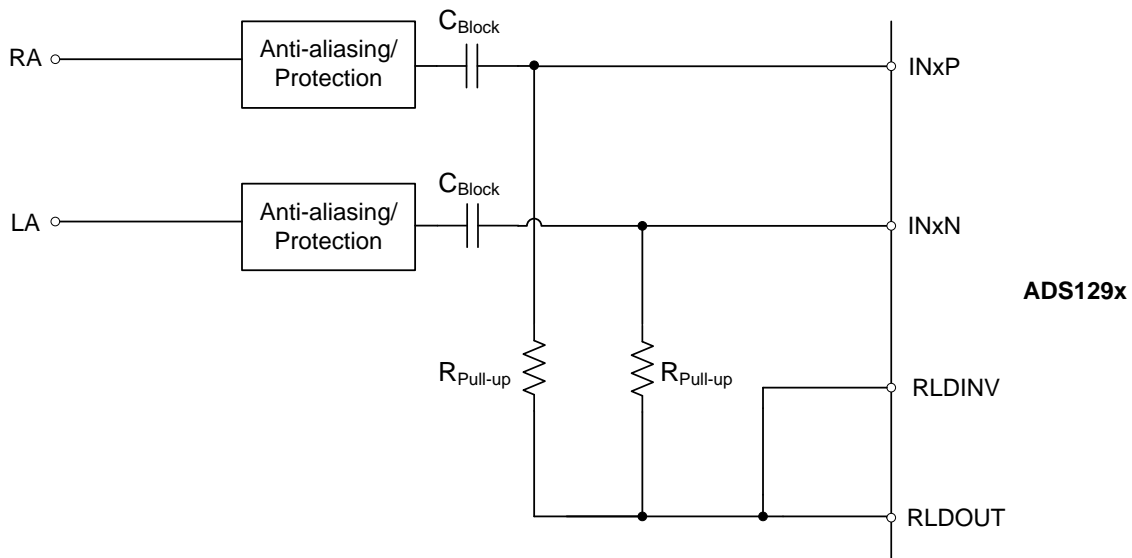

**Figure 95. Setting Common-Mode Without Using RLD Electrode**

## Application Information (continued)

### 10.1.3 Antialiasing

As with all analog-to-digital systems, take care to prevent undesired aliasing effects. The ADS129x modulator samples the input at either 256 kHz or 512 kHz, depending on whether the device is in low-power (LP) mode or high-resolution (HR) mode, respectively. As is the case with all digital filters, the response of the on-chip digital decimation filter on the ADS129x repeats at integer multiples of the modulator frequency. A benefit to using the delta-sigma architecture is that the digital decimation filter significantly attenuates frequencies between the signal band and the alias of the signal band near the modulator frequency. This attenuation, combined with the limited bandwidth of the PGA (see [Table 5](#)), makes the requirement on the steepness of the response of the analog antialiasing filter much less stringent. In many cases, acceptable attenuation at the modulator frequency is provided by either a single or double-pole RC low pass filter.

Also take care when choosing components for antialiasing. Common-mode to differential-mode conversion as a result of component mismatch, including antialiasing components, causes common-mode rejection degradation. [Figure 96](#) shows a typical front-end configuration.

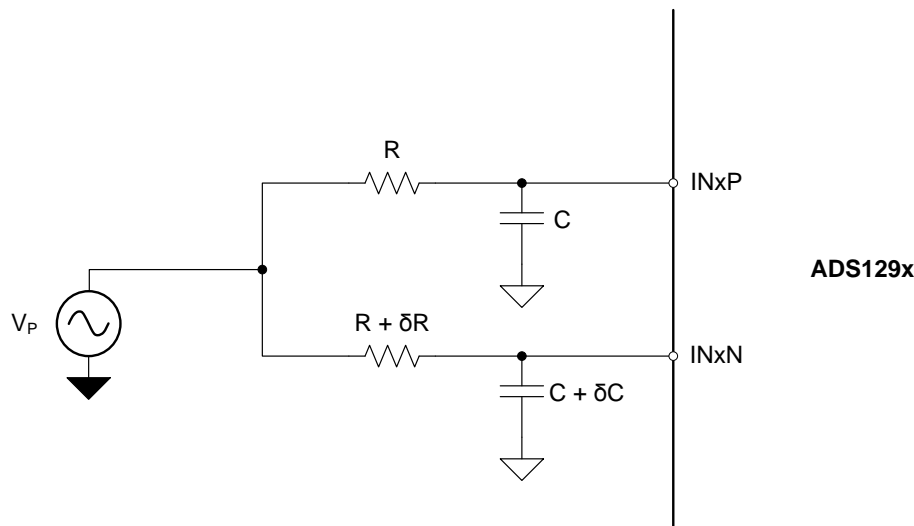

**Figure 96. Typical Front-End Configuration**

$V_p$  is the common-mode signal to the system. If the values of  $R$  and  $C$  modeled in the differential signal are perfectly matched, then the system exhibits a very large CMR. If  $\delta R$  and  $\delta C$  in resistor  $R$  and capacitor  $C$ , respectively, are mismatched, the CMR of the entire system is approximated to [Equation 8](#).

$$\text{CMR} = 20 \log \left( \frac{\delta R}{R} + \frac{\delta C}{C} \right) + 20 \log \left( \frac{f}{f_c} \right)$$

where

- $f_c$  is the  $-3$ -dB frequency of the RC filter. (8)

If 1%-precision external components are used and the bandwidth of the RC filter is approximately 6 kHz, the system then has only 74 dB of CMR at 60 Hz. In the real world, the front-end of the ECG does not contain only first-order RC filters; electrodes, cables, and second- or third-order RC filters are also included. Considering all of these components, mismatch can easily accumulate, and thus contribute up to 20% or more of the signal. This degree of mismatch degrades the CMR of the system to less than 60 dB at 60 Hz. Therefore, it is necessary to consider different techniques to improve CMR.

There is a tradeoff when placing the bandwidth of the antialiasing filter in front of the modulator. Considering the mismatch between the discrete components, it is better to select the large bandwidth; the upper limit of the bandwidth is determined by the sampling frequency of the modulator. For more information on ways to prevent common-mode rejection, see *Improving Common-Mode Rejection Using the Right-Leg Drive Amplifier*, [SBAA188](#).

## 10.2 Typical Applications

### 10.2.1 ADS129xR Respiration Measurement Using Internal Modulation Circuitry

The respiration measurement circuitry on the ADS129xR employs out-of-band amplitude modulation and demodulation to measure changes in thoracic impedance that correspond to breathing. When respiration mode is enabled, channel 1 cannot be used to acquire ECG signals because the internal demodulation circuitry is unique to that channel. ECG signals can still be acquired with the same electrodes used for respiration measurement if they are also connected to another channel. Note the configuration shown in [Figure 97](#).

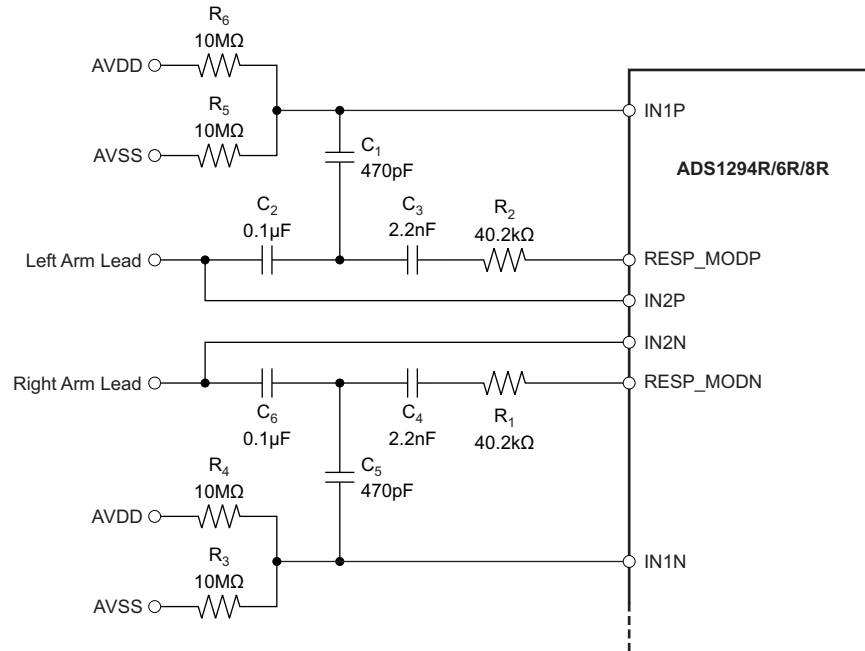

NOTE: Patient and input protection circuitry not shown.

**Figure 97. Typical Respiration Circuitry**

#### 10.2.1.1 Design Requirements

[Table 36](#) shows the design requirements for the components shown in [Figure 97](#).

**Table 36. Respiration Design Requirements**

DESIGN PARAMETER	VALUE
Modulation frequency	32 kHz or 64 kHz
Input high-pass filter cutoff	≈ 68 Hz
ADC reference voltage	2.4 V
Maximum ac body current	100 μA
Minimum resistance $R_1 + R_2$	24 kΩ

#### 10.2.1.2 Detailed Design Procedure

To configure the ADS129xR to use its internal modulation circuitry, set RESP register bits[6:7] to enable both the internal modulation and demodulation circuitry. RESP register bits[4:2] determine the phase of the demodulation blocking signal. To configure the device to use the internally generated signals for internal respiration measurement, configure RESP register bits[1:0] to 10b.

The RESP\_MODP and RESP\_MODN pins produce a 32 kHz or 64 kHz square wave depending on the CONFIG4 register bits[7:5] when configured to use the internal circuitry. The RESP\_MODP and RESP\_MODN pin voltages toggle between VREFP and VREFN at opposite phases at the specified frequency.

Choosing  $R_1$  and  $R_2$  involves first recognizing the ideal behavior of this circuit. Ideally, all of the series capacitors appear as short-circuits to the high-frequency modulation signal, and there is no nonideal shunt capacitance anywhere in the circuit. [Figure 98](#) shows an equivalent circuit representing these assumptions.

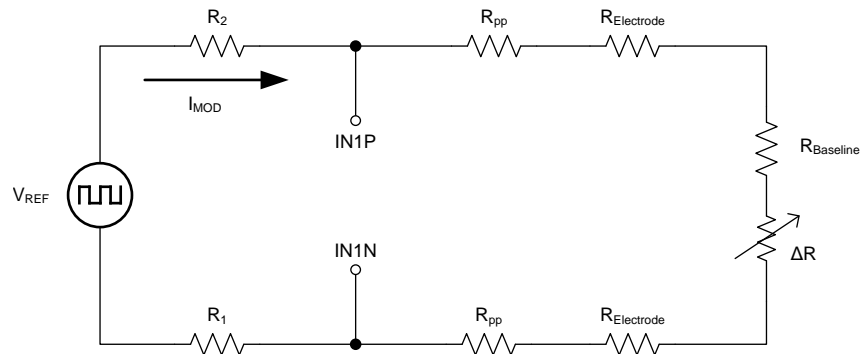

**Figure 98. Ideal Behavior of the Respiration Modulation Circuit.**

The voltage appearing at the channel 1 input is set by the voltage divider formed by the resistors in the circuit. Resistor  $R_{PP}$  represents any patient protection resistance in the cable;  $R_{Electrode}$  represents the electrode-to-body interface resistance;  $R_{Baseline}$  represents the baseline body impedance; and  $\Delta R$  is the change in thoracic impedance due to respiration. Assume that  $R_1$  and  $R_2$  are significantly larger than all the other resistors in the circuit, and then approximate the RESP\_MOD pins as the terminals of an ac current source with magnitude  $I_{MOD}$  according to [Equation 9](#):

$$I_{MOD} \approx \frac{V_{REF}}{R_1 + R_2}$$

where

- $V_{REF}$  is the square wave with the amplitude  $V_{REFP} - V_{REFN}$  that is produced at the RESP\_MOD pins. (9)

According to IEC60601, patient current at a frequency of 32 kHz must be limited to less than 100  $\mu A$ ; this limitation places a minimum value on the combination of  $R_1$  and  $R_2$ .

For best performance, the inputs to the ADS129xR must be ac coupled and biased to midsupply. The components that perform this function correspond to C1, C5, R3, R4, R5, and R6 in [Figure 97](#). It is possible for ECG interference to couple into channel 1. As a result of this possibility, it is advisable to make the high-pass filter cutoff of those components large enough to attenuate the ECG bandwidth significantly. Conversely, if the cutoff is set to high, the carrier signal may attenuate.

The signal that appears at the channel 1 input is amplified by the PGA, and then fed to the internal demodulation block. The demodulation block removes the square wave from the input leaving only the very low-frequency waveform corresponding to the  $\Delta R$  due to respiration, and the offset due to  $R_{PP}$ ,  $R_{Electrode}$ , and  $R_{Baseline}$ . [Equation 10](#) describes the modulator output voltage corresponding to the change in body impedance.

$$V_{RESP} = I_{MOD} \times \Delta R \times G_{PGA} \quad (10)$$

Measure the rate of respiration by using the period at which  $V_{RESP}$  oscillates as a result of  $\Delta R$ . Make sure that the magnitude of  $V_{RESP}$  remains greater than the noise-free resolution of the ADS129x. This magnitude imposes upper limits on the sizes of  $R_1$  and  $R_2$ , as well as the cable impedance  $R_{PP}$ , and demands that the quality of the electrode-to-body connection is high.

Parasitic shunt capacitance tends to attenuate high frequencies and the outputs from the PGA are limited by the bandwidth of the amplifiers. The result is that the square edges of the carrier are rounded. To account for this error, the ADS129xR allows configuration of the RESP\_PH[2:0] bits in the RESP register. Those bits control the demodulation phase that introduces a phase delay between the modulation and demodulation clocks to account for the delay introduced by low-pass elements in the circuit.

Choosing the optimal phase depends on the system characteristics. The time constant introduced by the resistance in the path of the input and the cable capacitance is an example of a system level characteristic that influences the amount of phase required for optimal respiration rate measurement.

Figure 99 shows a respiration test circuit. Figure 100 and Figure 101 plot noise on channel 1 for the ADS129xR as baseline impedance, gain, and phase are swept. The x-axis is the baseline impedance, normalized to a 29- $\mu$ A modulation current (see Equation 11).

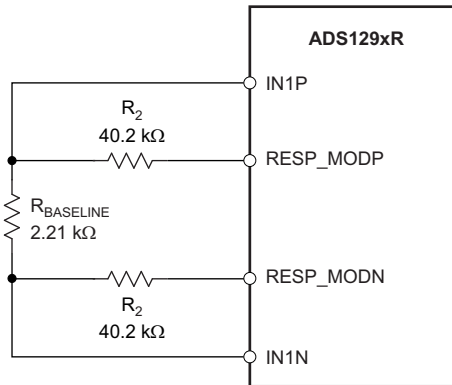
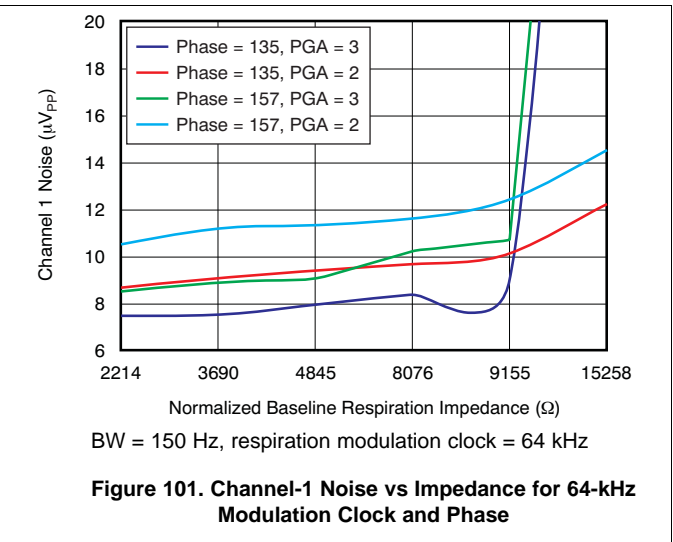
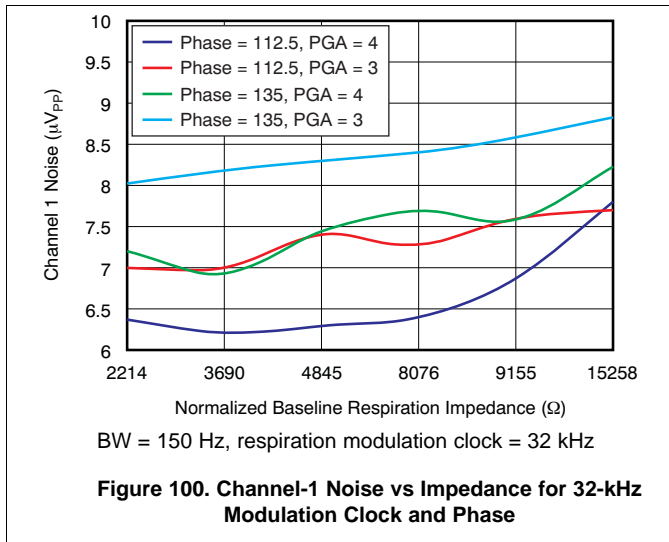

Figure 99. Respiration-Noise Test Circuit



$$R_{\text{NORMALIZED}} = \frac{R_{\text{ACTUAL}} \times I_{\text{ACTUAL}}}{29\mu\text{A}}$$

where

- $R_{\text{ACTUAL}}$  is the baseline body impedance.
- $I_{\text{ACTUAL}}$  is the modulation current, as calculated by  $(V_{\text{REFP}} - V_{\text{REFN}})$  divided by the impedance of the modulation circuit.

(11)

For example, assume that:

- Modulation frequency = 32 kHz
- $R_{\text{ACTUAL}} = 3 \text{ k}\Omega$
- $I_{\text{ACTUAL}} = 50 \mu\text{A}$
- $R_{\text{NORMALIZED}} = (3 \text{ k}\Omega \times 50 \mu\text{A}) / 29 \mu\text{A} = 5.1 \text{ k}\Omega$

Referring to Figure 100 and Figure 101, gain = 4 and phase = 112.5° yield the best performance at 6.4  $\mu\text{V}_{\text{PP}}$ . Low-pass filtering this signal with a high-order, 2-Hz cutoff reduces the noise to less than 600  $\text{nV}_{\text{PP}}$ . The impedance resolution is 600  $\text{nV}_{\text{PP}} / 29 \mu\text{A} = 20 \text{ m}\Omega$ . When the modulation frequency is 32 kHz, use gains of 3 and 4, and a phase of 112.5° and 135° for best performance. When the modulation frequency is 64 kHz, use gains of 2 and 3 and phase of 135° and 157° for best performance.

### 10.2.1.3 Application Curve

Figure 102 shows respiration data taken with the ADS1298RECGFE-PDK using the Fluke medSim 300b. The data was then low-pass filtered to attenuate noise outside of the band of interest. A modulation frequency of 32 kHz was used along with a PGA gain of 3 and a RESP\_PH setting of 112.5°.

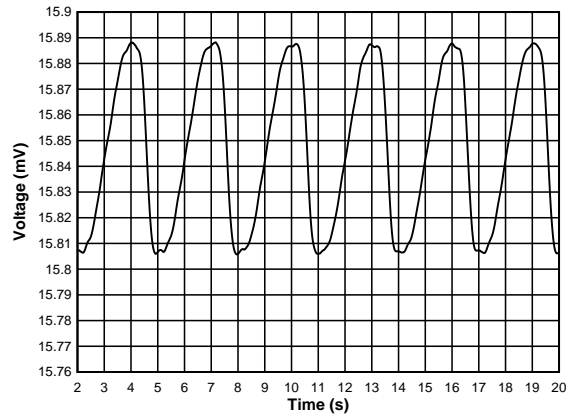

Figure 102. Respiration Impedance Taken With ADS1298R

### 10.2.2 Software-Based Artificial Pacemaker Detection Using the PACEOUT Pins on the ADS129x

The electrical pulses produced by an artificial pacemaker are used to regulate the beating of the heart, and have a very small duration (width) when measured on the scale of other biopotential signals. According to the standard listed in AAMI EC11, medical instrumentation must be capable of capturing pacemaker pulses with durations as narrow as 0.5 ms. The ADS129x is capable of capturing data at 32 kSPS; ideally, fast enough to capture even the narrowest pulse. However, the data rate setting on the ADS129x is global for all channels. Using the ADS129x to digitize an input channel fast enough for robust pacemaker detection dictates that all channels must be converted as quickly; a condition that may be undesirable.

An alternative topology is to use the ADS129x internal pace buffers to route a single-ended version of any particular channel input out to a fast-sampling SAR ADC to digitize the detection channel signal separately. Detection of a pacemaker pulse is then performed in the digital domain. Refer to [Figure 103](#) for the basic block diagram for this architecture. The example features the combination of the [OPA320](#) and the [ADS7042](#). The OPA320 is used to drive the input sampling structure of the ADS7042, but provides corollary flexibility to add another gain stage and active antialias filtering before the pace output is digitized.

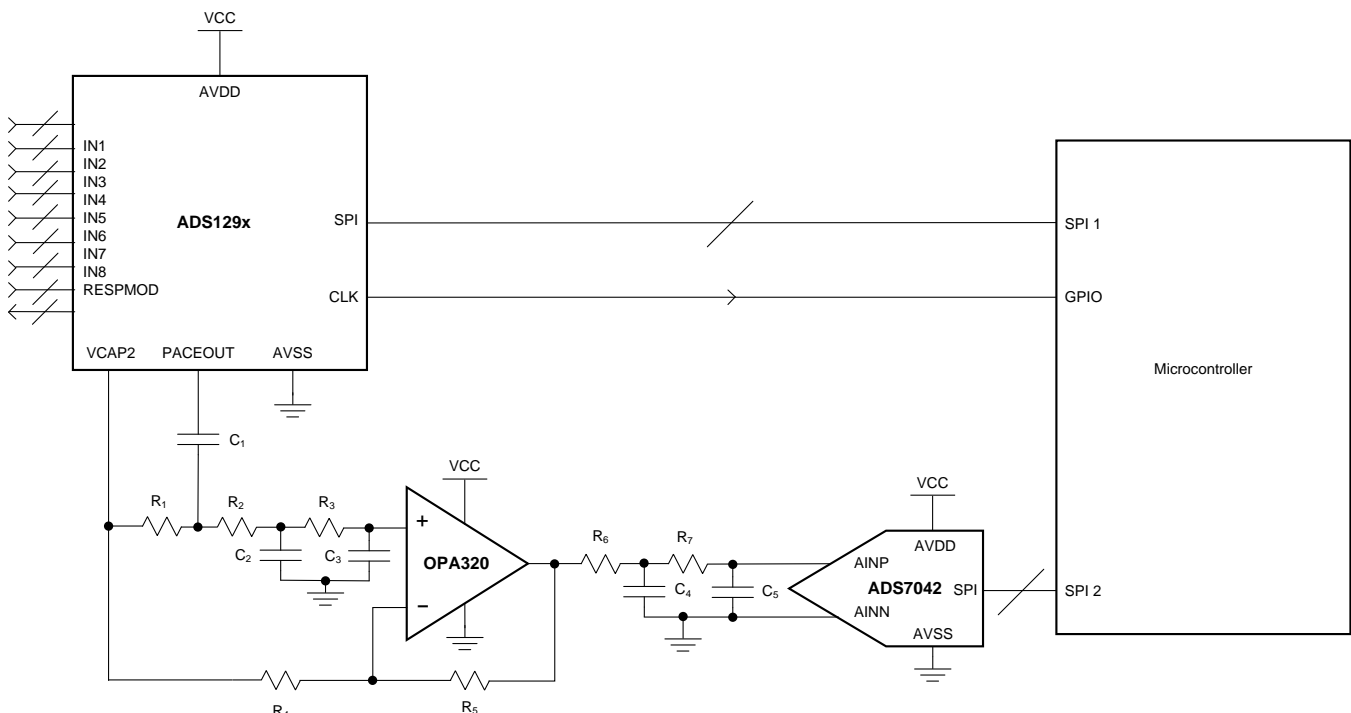

Figure 103. Block Diagram of the Software Pacemaker Detection Topology

#### 10.2.2.1 Design Requirements

Table 37 shows the design requirements for the components shown in [Figure 103](#).

Table 37. Software Pace Design Requirements

DESIGN PARAMETER	VALUE
Analog supply voltage	3.3 V
Minimum pacemaker signal bandwidth	0.5 ms
Minimum pacemaker signal amplitude	2 mV
Feedback network $R_4 + R_5$ (nonunity gain)	$\approx 100 \text{ k}\Omega$

### 10.2.2.2 Detailed Design Procedure

The pace amplifiers on the ADS129x provides differential to single-ended conversion and amplification of 0.4 V/V to whatever voltage appears at the output of the PGA of the channel from which the pace amplifier is routed. Selecting which channels are routed to the pace amplifiers is performed in the pace detect register of the ADS129x. The voltage that appears at the output of the pace amplifier is to be taken with respect to analog midsupply.

Before the signal is converted by the ADS7042, the signal must be buffered by a high-speed op amp because the inputs of the ADS7042 represent a switch-capacitor type load. The OPA320 is ideal to perform this function because of the low input bias current and 20-MHz unity gain bandwidth. The op amp also provides the flexibility to provide an extra gain stage before the SAR ADC, isolate filter stages, or to provide simple buffering. The purpose of  $C_1$  and  $R_1$  are to provide ac coupling to the pacemaker detection signal. This coupling may be necessary because electrode offset and the pacemaker pulse can both be, in some cases, up to a few hundred millivolts.

An actively-driven signal ground is required to set the dc bias of the op amp at midsupply. It is possible to use the voltage provided at VCAP2 on the ADS129x as a buffered midsupply voltage. The voltage at the VCAP2 pin may be noisy, but using it to drive the common-mode voltage for both inverting and noninverting inputs to the op amp causes the op amp to cancel that noise significantly because it is common to both inputs.

Op amp feedback resistors  $R_4$  and  $R_5$  set the gain for the OPA320. The transfer function for this configuration is that of the noninverting op amp configuration shown in [Equation 12](#).

$$v_o = v_i \left( 1 + \frac{R_3}{R_2} \right) \quad (12)$$

Resistors  $R_4$  and  $R_5$  are chosen to set the desired gain. The series combination is approximately 100 k $\Omega$ , so that both the feedback current is limited to within the ADS129x VCAP2 internal regulator drive strength, and the Johnson-Nyquist noise of the resistors remains negligible.

If the OPA320 is to be used only as a buffer, remove  $R_4$  removed to provide unity gain. If ac coupling is not desired, for best performance, replace  $C_1$  with a 0- $\Omega$  resistor and depopulate  $R_1$ .

The RC network of  $R_2$ ,  $C_2$ ,  $R_3$ ,  $C_3$ ,  $R_6$ ,  $C_4$ ,  $R_7$ , and  $C_5$  form isolated two-pole RC antialiasing filters for the SAR ADC. The component values of the filter are set to provide significant attenuation at the ADC sampling frequency, but still provide enough bandwidth to detect a pacemaker pulse. A bandwidth of greater than 2 kHz is enough to capture a narrow 0.5-ms pacemaker pulse.

In a real-time system, data must be collected and analyzed for a pacemaker with each incoming sample. Digitally filter data that are collected from the ADS7042 to remove out-of-band noise. Unlike a delta-sigma converter, a SAR converter does not apply a filter to the data before it is sent to the host. There are a number of factors that drive a decision on digital-filter implementation. Some of those factors include steepness of the response, phase linearity, and the number of taps. When using this topology with an ADS129xR device simultaneously with the respiration measurement circuitry, take special care to remove noise generated by the respiration modulation circuitry.

The key to detecting a pacemaker pulse is the detection of a steep transition in the input voltage. To measure the magnitude of the transitions in input voltages, apply a digital differentiator algorithm. The algorithm measures the change in voltage magnitude over the span of a few samples and compares the change to a threshold required to trigger detection. The following pseudocode exemplifies some of the processing steps required to use this topology:

```

newDataPoint = collectFromADS7042( );           // Collect data from the ADS7042
                                                // Apply combined low-pass filter and differentiator
inputRateOfChange = LPFandDifferentiator( newDataPoint );
if( abs( inputRateOfChange ) > thresholdValue ) // Check if a quick edge occurred
{
    pacemakerFlag = true;                       // Edge detected
}

```

**10.2.2.3 Application Curve**

Figure 104 shows data that was collected from the PACEOUT pin of the ADS1298R (using the OPA320 and the ADS7042), and then filtered. The pacemaker pulse can be clearly identified.

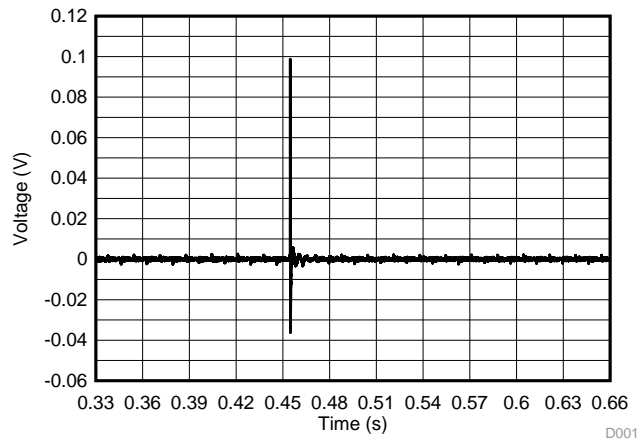

NOTE: For illustration purposes, plot data were not processed in real time. As a result of the lack of shielding in this particular configuration, data were also high-pass filtered to attenuate the utility noise.

**Figure 104. Filtered ADS7042 Output Data With Pacemaker Pulse**

## 11 Power Supply Recommendations

The ADS129x have three power supplies: AVDD, AVDD1, and DVDD. For best performance, both AVDD and AVDD1 must be as quiet as possible. AVDD1 provides the supply to the charge pump block and has transients at  $f_{CLK}$ . Therefore, star connect AVDD1 and AVSS1 to AVDD and AVSS. It is important to eliminate noise from AVDD and AVDD1 that is nonsynchronous with ADS129x operation. Bypass each ADS129x supply with 1- $\mu$ F and 0.1- $\mu$ F solid ceramic capacitors. For best performance, place the digital circuits (DSP, microcontrollers, FPGAs, and so forth) in the system so that the return currents on those devices do not cross the analog return path of the ADS129x. Power the ADS129x from unipolar or bipolar supplies.

Use surface-mount, low-cost, low-profile, multilayer ceramic-type capacitors for decoupling. In most cases, the VCAP1 capacitor is also a multilayer ceramic; however, in systems where the board is subjected to high- or low-frequency vibration, install a nonferroelectric capacitor, such as a tantalum or class 1 capacitor (C0G or NPO). EIA class 2 and class 3 dielectrics such as (X7R, X5R, X8R, and so forth) are ferroelectric. The piezoelectric property of these capacitors can appear as electrical noise coming from the capacitor. When using internal reference, noise on the VCAP1 node results in performance degradation.

### 11.1 Power-Up Sequencing

Before device power up, all digital and analog inputs must be low. At the time of power up, keep all of these signals low until the power supplies have stabilized, as shown in [Figure 105](#).

Allow time for the supply voltages to reach their final value, and then begin supplying the master clock signal to the CLK pin. Wait for time  $t_{POR}$ , then transmit a reset pulse using either the RESET pin or RESET command to initialize the digital portion of the chip. Issue the reset after  $t_{POR}$  or after the VCAP1 voltage is greater than 1.1 V, whichever time is longer. Note that:

- $t_{POR}$  is described in [Table 38](#).
- The VCAP1 pin charge time is set by the RC time constant; see [Figure 31](#).

After releasing the  $\overline{\text{RESET}}$  pin, program the configuration registers; see the [CONFIG1: Configuration Register 1 \(address = 01h\) \(reset = 06h\)](#) section for details. The power-up sequence timing is shown in [Table 38](#).

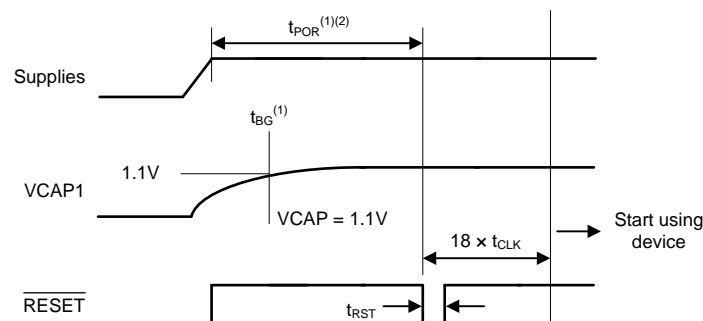

- (1) Timing to reset pulse is  $t_{POR}$  or after  $t_{BG}$ , whichever is longer.
- (2) When using an external clock,  $t_{POR}$  timing does not start until CLK is valid.

**Figure 105. Power-Up Timing Diagram**

**Table 38. Timing Requirements for [Figure 105](#)**

		MIN	MAX	UNIT
$t_{POR}$	Wait after power up until reset	$2^{18}$		$t_{CLK}$
$t_{RST}$	Reset low duration	2		$t_{CLK}$

### 11.2 Connecting to Unipolar (3 V or 1.8 V) Supplies

Figure 106 illustrates the ADS129x connected to a unipolar supply. In this example, analog supply (AVDD) is referenced to analog ground (AVSS) and digital supplies (DVDD) are referenced to digital ground (DGND).

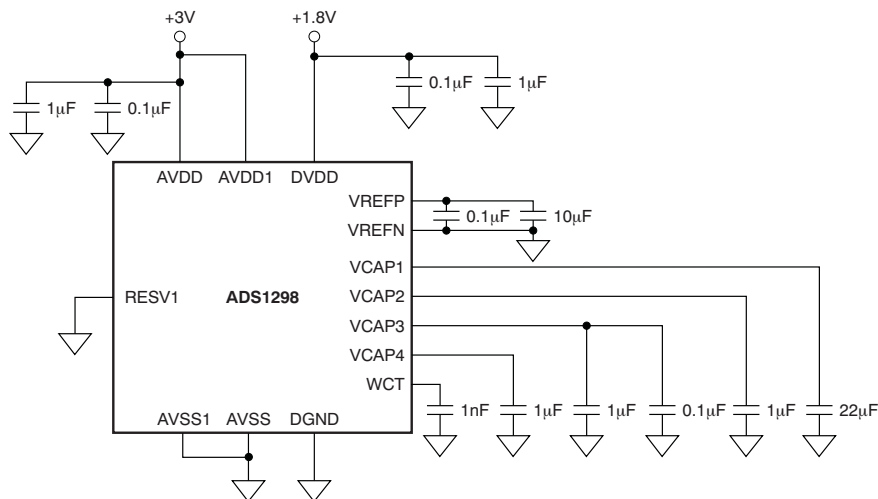

NOTE: Place the capacitors for supply, reference, WCT, and VCAP1 to VCAP4 as close to the package as possible.

Figure 106. Single-Supply Operation

### 11.3 Connecting to Bipolar ( $\pm 1.5$ V or $\pm 1.8$ V) Supplies

Figure 107 illustrates the ADS129x connected to a bipolar supply. In this example, the analog supplies connect to the device analog supply (AVDD). This supply is referenced to the device analog return (AVSS), and the digital supply (DVDD) is referenced to the device digital ground return (DGND).

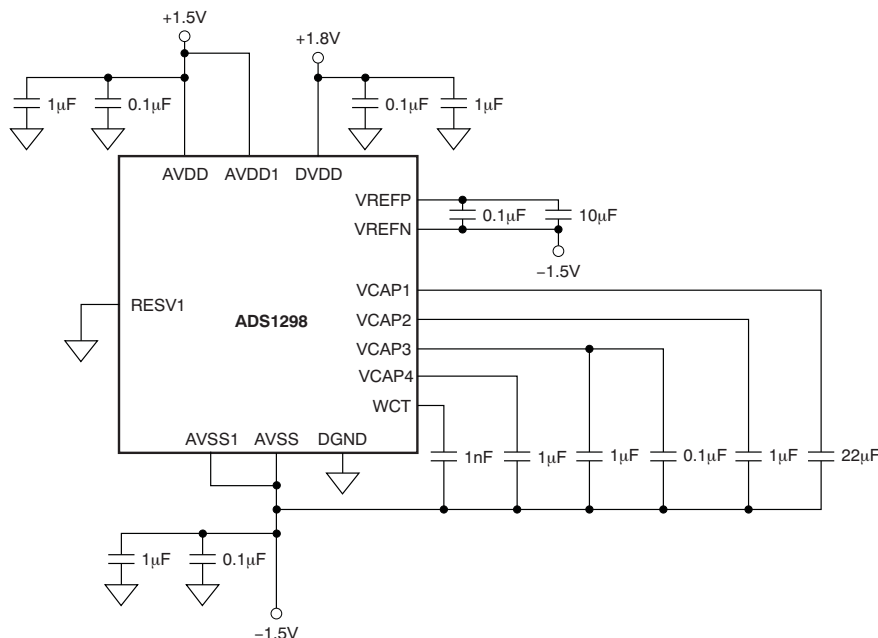

NOTE: Place the capacitors for supply, reference, WCT, and VCAP1 to VCAP4 as close to the package as possible.

Figure 107. Bipolar Supply Operation

## 12 Layout

### 12.1 Layout Guidelines

Use a low-impedance connection for ground, so that return currents flow undisturbed back to their respective sources. For best performance, dedicate an entire PCB layer to a ground plane and route no other signal traces on this layer. Keep connections to the ground plane as short and direct as possible. When using vias to connect to the ground layer, use multiple vias in parallel to reduce impedance to ground.

A mixed signal layout sometimes incorporates separate analog and digital ground planes that are tied together at one location; however, separating the ground planes is not necessary when analog, digital and power supply components are properly placed. Proper placement of components partitions the analog, digital and power supply circuitry into different PCB regions to prevent digital return currents from coupling into sensitive analog circuitry. If ground plane separation is necessary, then make the connection at the ADC. Connecting individual ground planes at multiple locations creates ground loops, and is not recommended. A single ground plane for analog and digital avoids ground loops.

Bypass supply pins with a low-ESR ceramic capacitor. The placement of the bypass capacitors must be as close as possible to the supply pins using short, direct traces. For optimum performance, the ground-side connections of the bypass capacitors must also be low-impedance connections. The supply current flows through the bypass capacitor pin first and then to the supply pin to make the bypassing most effective (also known as a Kelvin connection). If multiple ADCs are on the same PCB, use wide power-supply traces or dedicated power-supply planes to minimize the potential of crosstalk between ADCs.

If external filtering is used for the analog inputs, use COG-type ceramic capacitors when possible. COG capacitors have stable properties and low-noise characteristics. Ideally, route differential signals as pairs to minimize the loop area between the traces. Route digital circuit traces (such as clock signals) away from all analog pins. Note the internal reference output return shares the same pin as the AVSS power supply. To minimize coupling between the power-supply trace and reference return trace, route the two traces separately; ideally, as a star connection at the AVSS pin.

It is essential to make short, direct interconnections on analog input lines and avoid stray wiring capacitance, particularly between the analog input pins and AVSS. These analog input pins are high-impedance and extremely sensitive to extraneous noise. Treat the AVSS pin as a sensitive analog signal and connect directly to the supply ground with proper shielding. Leakage currents between the PCB traces can exceed the input bias current of the ADS129x if shielding is not implemented. Keep digital signals as far as possible from the analog input signals on the PCB.

It is important the SCLK input of the serial interface is free from noise and glitches. Even with relatively slow SCLK frequencies, short digital signal rise and fall times may cause excessive ringing and noise. For best performance, keep the digital signal traces short, using termination resistors as needed, and make sure all digital signals are routed directly above the ground plane with minimal use of vias.

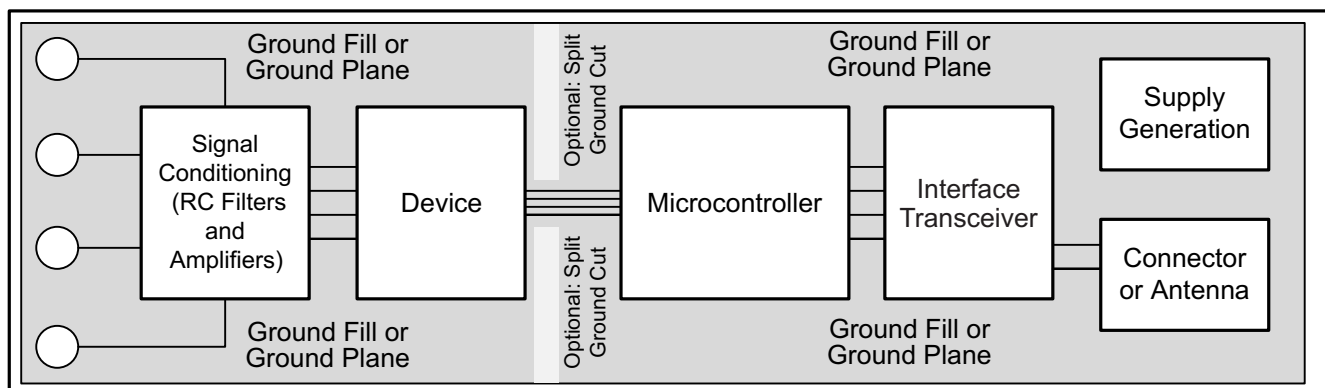

**Figure 108. System Component Placement**

## 12.2 Layout Example

Figure 109 is an example layout of the ADS129x requiring a minimum of two PCB layers. The example circuit is shown for either a single analog supply or a bipolar-supply connection. In this example, polygon pours are used as supply connections around the device. If a three- or four-layer PCB is used, the additional inner layers can be dedicated to route power traces. The PCB is partitioned with analog signals routed from the left, digital signals routed to the right, and power routed above and below the device.

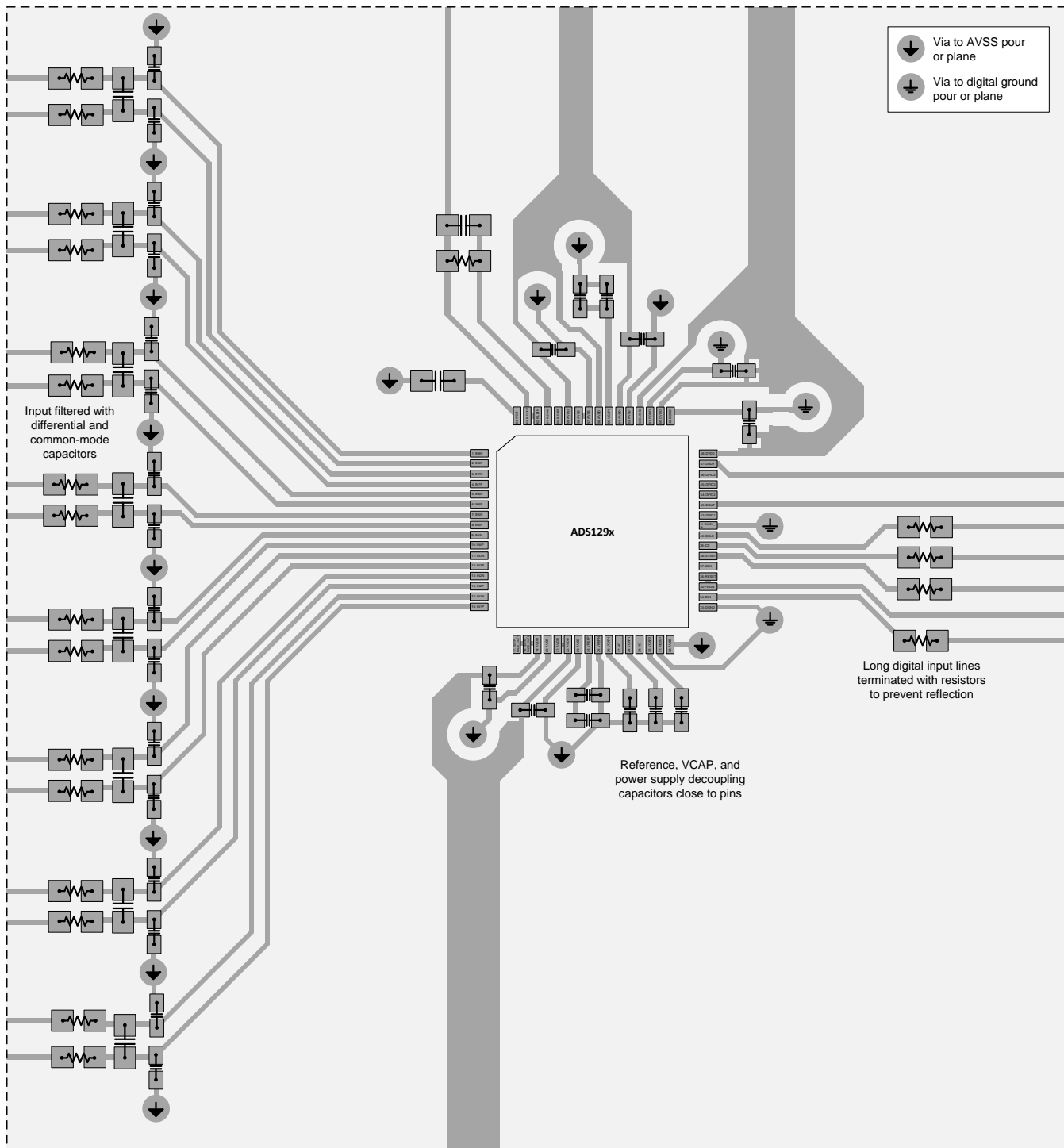

Figure 109. ADS129x Layout Example

## 13 Device and Documentation Support

### 13.1 Related Links

[Table 39](#) lists quick access links. Categories include technical documents, support and community resources, tools and software, and quick access to sample or buy.

**Table 39. Related Links**

PARTS	PRODUCT FOLDER	SAMPLE & BUY	TECHNICAL DOCUMENTS	TOOLS & SOFTWARE	SUPPORT & COMMUNITY
ADS1294	<a href="#">Click here</a>	<a href="#">Click here</a>	<a href="#">Click here</a>	<a href="#">Click here</a>	<a href="#">Click here</a>
ADS1294R	<a href="#">Click here</a>	<a href="#">Click here</a>	<a href="#">Click here</a>	<a href="#">Click here</a>	<a href="#">Click here</a>
ADS1296	<a href="#">Click here</a>	<a href="#">Click here</a>	<a href="#">Click here</a>	<a href="#">Click here</a>	<a href="#">Click here</a>
ADS1296R	<a href="#">Click here</a>	<a href="#">Click here</a>	<a href="#">Click here</a>	<a href="#">Click here</a>	<a href="#">Click here</a>
ADS1298	<a href="#">Click here</a>	<a href="#">Click here</a>	<a href="#">Click here</a>	<a href="#">Click here</a>	<a href="#">Click here</a>
ADS1298R	<a href="#">Click here</a>	<a href="#">Click here</a>	<a href="#">Click here</a>	<a href="#">Click here</a>	<a href="#">Click here</a>

### 13.2 Community Resources

The following links connect to TI community resources. Linked contents are provided "AS IS" by the respective contributors. They do not constitute TI specifications and do not necessarily reflect TI's views; see TI's [Terms of Use](#).

**TI E2E™ Online Community** *TI's Engineer-to-Engineer (E2E) Community*. Created to foster collaboration among engineers. At [e2e.ti.com](http://e2e.ti.com), you can ask questions, share knowledge, explore ideas and help solve problems with fellow engineers.

**Design Support** *TI's Design Support* Quickly find helpful E2E forums along with design support tools and contact information for technical support.

### 13.3 Trademarks

E2E is a trademark of Texas Instruments.

SPI is a trademark of Motorola Inc.

All other trademarks are the property of their respective owners.

### 13.4 Electrostatic Discharge Caution



These devices have limited built-in ESD protection. The leads should be shorted together or the device placed in conductive foam during storage or handling to prevent electrostatic damage to the MOS gates.

### 13.5 Glossary

[SLYZ022](#) — *TI Glossary*.

This glossary lists and explains terms, acronyms, and definitions.

## 14 Mechanical, Packaging, and Orderable Information

The following pages include mechanical, packaging, and orderable information. This information is the most current data available for the designated devices. This data is subject to change without notice and revision of this document. For browser-based versions of this data sheet, refer to the left-hand navigation.

**PACKAGING INFORMATION**

Orderable Device	Status (1)	Package Type	Package Drawing	Pins	Package Qty	Eco Plan (2)	Lead finish/ Ball material (6)	MSL Peak Temp (3)	Op Temp (°C)	Device Marking (4/5)	Samples
ADS1294CZXGR	ACTIVE	NFBGA	ZXG	64	1000	RoHS & Green	SNAGCU	Level-3-260C-168 HR	0 to 70	ADS1294	<a href="#">Samples</a>
ADS1294CZXGT	ACTIVE	NFBGA	ZXG	64	250	RoHS & Green	SNAGCU	Level-3-260C-168 HR	0 to 70	ADS1294	<a href="#">Samples</a>
ADS1294IPAG	ACTIVE	TQFP	PAG	64	160	RoHS & Green	NIPDAU	Level-3-260C-168 HR	-40 to 85	ADS1294	<a href="#">Samples</a>
ADS1294IPAGR	ACTIVE	TQFP	PAG	64	1500	RoHS & Green	NIPDAU	Level-3-260C-168 HR	-40 to 85	ADS1294	<a href="#">Samples</a>
ADS1294RIZXGR	ACTIVE	NFBGA	ZXG	64	1000	RoHS & Green	SNAGCU	Level-3-260C-168 HR	-40 to 85	ADS1294R	<a href="#">Samples</a>
ADS1294RIZXGT	ACTIVE	NFBGA	ZXG	64	250	RoHS & Green	SNAGCU	Level-3-260C-168 HR	-40 to 85	ADS1294R	<a href="#">Samples</a>
ADS1296CZXGR	ACTIVE	NFBGA	ZXG	64	1000	RoHS & Green	SNAGCU	Level-3-260C-168 HR	0 to 70	ADS1296	<a href="#">Samples</a>
ADS1296CZXGT	ACTIVE	NFBGA	ZXG	64	250	RoHS & Green	SNAGCU	Level-3-260C-168 HR	0 to 70	ADS1296	<a href="#">Samples</a>
ADS1296IPAG	ACTIVE	TQFP	PAG	64	160	RoHS & Green	NIPDAU	Level-3-260C-168 HR	-40 to 85	ADS1296	<a href="#">Samples</a>
ADS1296IPAGR	ACTIVE	TQFP	PAG	64	1500	RoHS & Green	NIPDAU	Level-3-260C-168 HR	-40 to 85	ADS1296	<a href="#">Samples</a>
ADS1296RIZXGR	ACTIVE	NFBGA	ZXG	64	1000	RoHS & Green	SNAGCU	Level-3-260C-168 HR	-40 to 85	ADS1296R	<a href="#">Samples</a>
ADS1296RIZXGT	ACTIVE	NFBGA	ZXG	64	250	RoHS & Green	SNAGCU	Level-3-260C-168 HR	-40 to 85	ADS1296R	<a href="#">Samples</a>
ADS1298CZXGR	ACTIVE	NFBGA	ZXG	64	1000	RoHS & Green	SNAGCU	Level-3-260C-168 HR	0 to 70	ADS1298	<a href="#">Samples</a>
ADS1298CZXGT	ACTIVE	NFBGA	ZXG	64	250	RoHS & Green	SNAGCU	Level-3-260C-168 HR	0 to 70	ADS1298	<a href="#">Samples</a>
ADS1298IPAG	ACTIVE	TQFP	PAG	64	160	RoHS & Green	NIPDAU	Level-3-260C-168 HR	-40 to 85	ADS1298	<a href="#">Samples</a>
ADS1298IPAGR	ACTIVE	TQFP	PAG	64	1500	RoHS & Green	NIPDAU	Level-3-260C-168 HR	-40 to 85	ADS1298	<a href="#">Samples</a>
ADS1298RIZXGR	ACTIVE	NFBGA	ZXG	64	1000	RoHS & Green	SNAGCU	Level-3-260C-168 HR	-40 to 85	ADS1298R	<a href="#">Samples</a>
ADS1298RIZXGT	ACTIVE	NFBGA	ZXG	64	250	RoHS & Green	SNAGCU	Level-3-260C-168 HR	-40 to 85	ADS1298R	<a href="#">Samples</a>

<sup>(1)</sup> The marketing status values are defined as follows:

**ACTIVE:** Product device recommended for new designs.

**LIFEBUY:** TI has announced that the device will be discontinued, and a lifetime-buy period is in effect.

---

**NRND:** Not recommended for new designs. Device is in production to support existing customers, but TI does not recommend using this part in a new design.

**PREVIEW:** Device has been announced but is not in production. Samples may or may not be available.

**OBSOLETE:** TI has discontinued the production of the device.

<sup>(2)</sup> **RoHS:** TI defines "RoHS" to mean semiconductor products that are compliant with the current EU RoHS requirements for all 10 RoHS substances, including the requirement that RoHS substance do not exceed 0.1% by weight in homogeneous materials. Where designed to be soldered at high temperatures, "RoHS" products are suitable for use in specified lead-free processes. TI may reference these types of products as "Pb-Free".

**RoHS Exempt:** TI defines "RoHS Exempt" to mean products that contain lead but are compliant with EU RoHS pursuant to a specific EU RoHS exemption.

**Green:** TI defines "Green" to mean the content of Chlorine (Cl) and Bromine (Br) based flame retardants meet JS709B low halogen requirements of  $\leq 1000$ ppm threshold. Antimony trioxide based flame retardants must also meet the  $\leq 1000$ ppm threshold requirement.

<sup>(3)</sup> **MSL, Peak Temp.** - The Moisture Sensitivity Level rating according to the JEDEC industry standard classifications, and peak solder temperature.

<sup>(4)</sup> There may be additional marking, which relates to the logo, the lot trace code information, or the environmental category on the device.

<sup>(5)</sup> Multiple Device Markings will be inside parentheses. Only one Device Marking contained in parentheses and separated by a "~" will appear on a device. If a line is indented then it is a continuation of the previous line and the two combined represent the entire Device Marking for that device.

<sup>(6)</sup> **Lead finish/Ball material** - Orderable Devices may have multiple material finish options. Finish options are separated by a vertical ruled line. Lead finish/Ball material values may wrap to two lines if the finish value exceeds the maximum column width.

**Important Information and Disclaimer:** The information provided on this page represents TI's knowledge and belief as of the date that it is provided. TI bases its knowledge and belief on information provided by third parties, and makes no representation or warranty as to the accuracy of such information. Efforts are underway to better integrate information from third parties. TI has taken and continues to take reasonable steps to provide representative and accurate information but may not have conducted destructive testing or chemical analysis on incoming materials and chemicals. TI and TI suppliers consider certain information to be proprietary, and thus CAS numbers and other limited information may not be available for release.

In no event shall TI's liability arising out of such information exceed the total purchase price of the TI part(s) at issue in this document sold by TI to Customer on an annual basis.

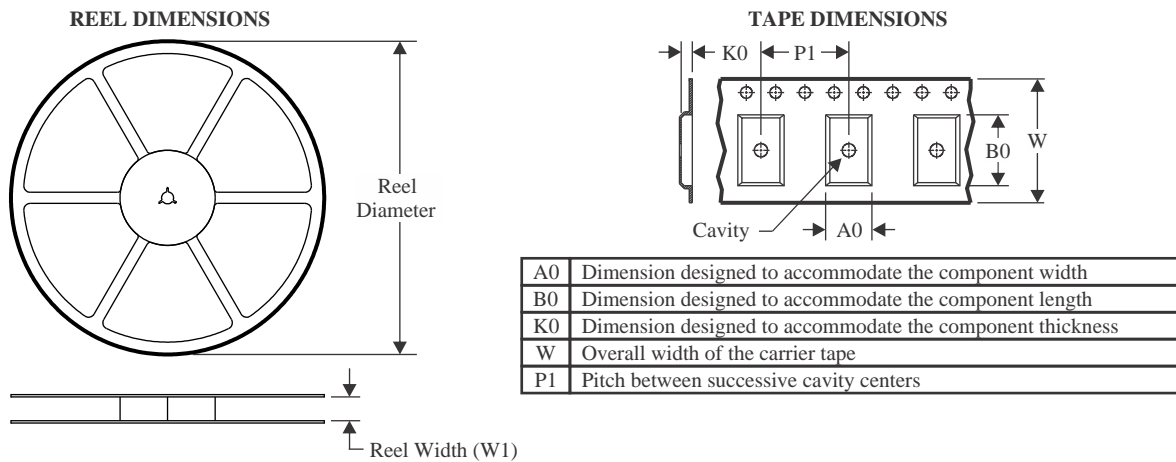
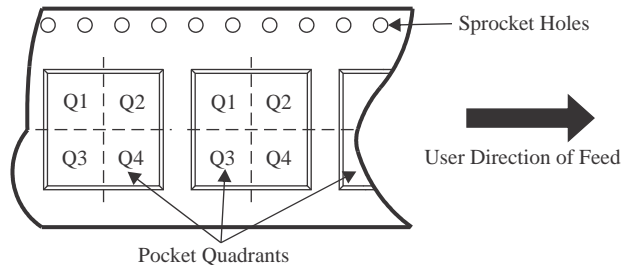
**TAPE AND REEL INFORMATION**

**QUADRANT ASSIGNMENTS FOR PIN 1 ORIENTATION IN TAPE**

\*All dimensions are nominal

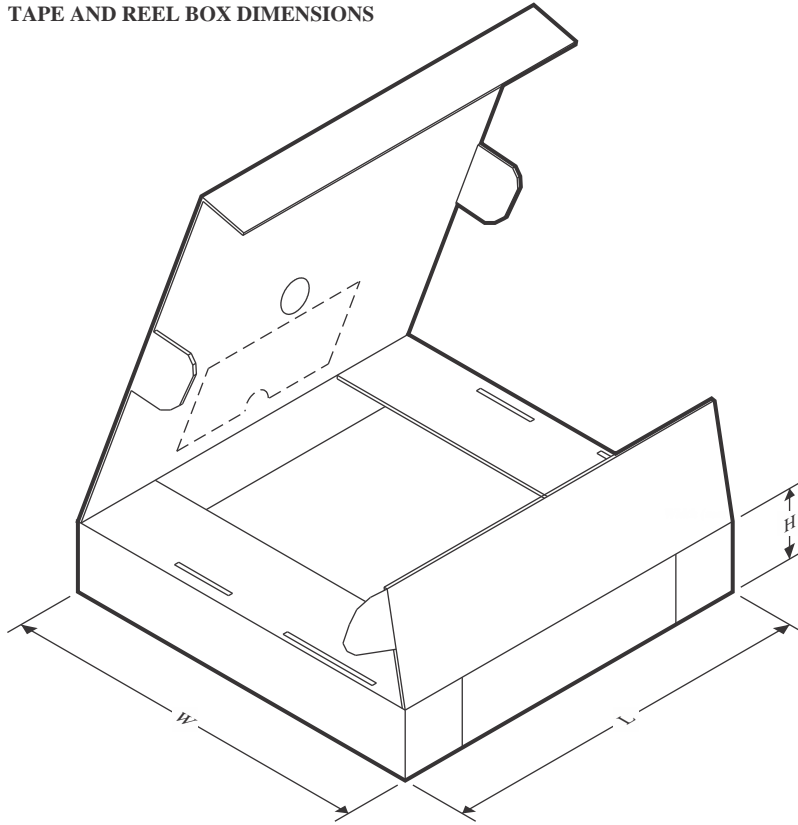
Device	Package Type	Package Drawing	Pins	SPQ	Reel Diameter (mm)	Reel Width W1 (mm)	A0 (mm)	B0 (mm)	K0 (mm)	P1 (mm)	W (mm)	Pin1 Quadrant
ADS1294CZXGR	NFBGA	ZXG	64	1000	330.0	16.4	8.3	8.3	2.25	12.0	16.0	Q1
ADS1294IPAGR	TQFP	PAG	64	1500	330.0	24.4	13.0	13.0	1.5	16.0	24.0	Q2
ADS1294RIZXGR	NFBGA	ZXG	64	1000	330.0	16.4	8.3	8.3	2.25	12.0	16.0	Q1
ADS1296CZXGR	NFBGA	ZXG	64	1000	330.0	16.4	8.3	8.3	2.25	12.0	16.0	Q1
ADS1296IPAGR	TQFP	PAG	64	1500	330.0	24.4	13.0	13.0	1.5	16.0	24.0	Q2
ADS1296RIZXGR	NFBGA	ZXG	64	1000	330.0	16.4	8.3	8.3	2.25	12.0	16.0	Q1
ADS1298CZXGR	NFBGA	ZXG	64	1000	330.0	16.4	8.3	8.3	2.25	12.0	16.0	Q1
ADS1298IPAGR	TQFP	PAG	64	1500	330.0	24.4	13.0	13.0	1.5	16.0	24.0	Q2
ADS1298RIZXGR	NFBGA	ZXG	64	1000	330.0	16.4	8.3	8.3	2.25	12.0	16.0	Q1

**TAPE AND REEL BOX DIMENSIONS**

\*All dimensions are nominal

Device	Package Type	Package Drawing	Pins	SPQ	Length (mm)	Width (mm)	Height (mm)
ADS1294CZXGR	NFBGA	ZXG	64	1000	350.0	350.0	43.0
ADS1294IPAGR	TQFP	PAG	64	1500	350.0	350.0	43.0
ADS1294RIZXGR	NFBGA	ZXG	64	1000	350.0	350.0	43.0
ADS1296CZXGR	NFBGA	ZXG	64	1000	350.0	350.0	43.0
ADS1296IPAGR	TQFP	PAG	64	1500	350.0	350.0	43.0
ADS1296RIZXGR	NFBGA	ZXG	64	1000	350.0	350.0	43.0
ADS1298CZXGR	NFBGA	ZXG	64	1000	350.0	350.0	43.0
ADS1298IPAGR	TQFP	PAG	64	1500	350.0	350.0	43.0
ADS1298RIZXGR	NFBGA	ZXG	64	1000	350.0	350.0	43.0

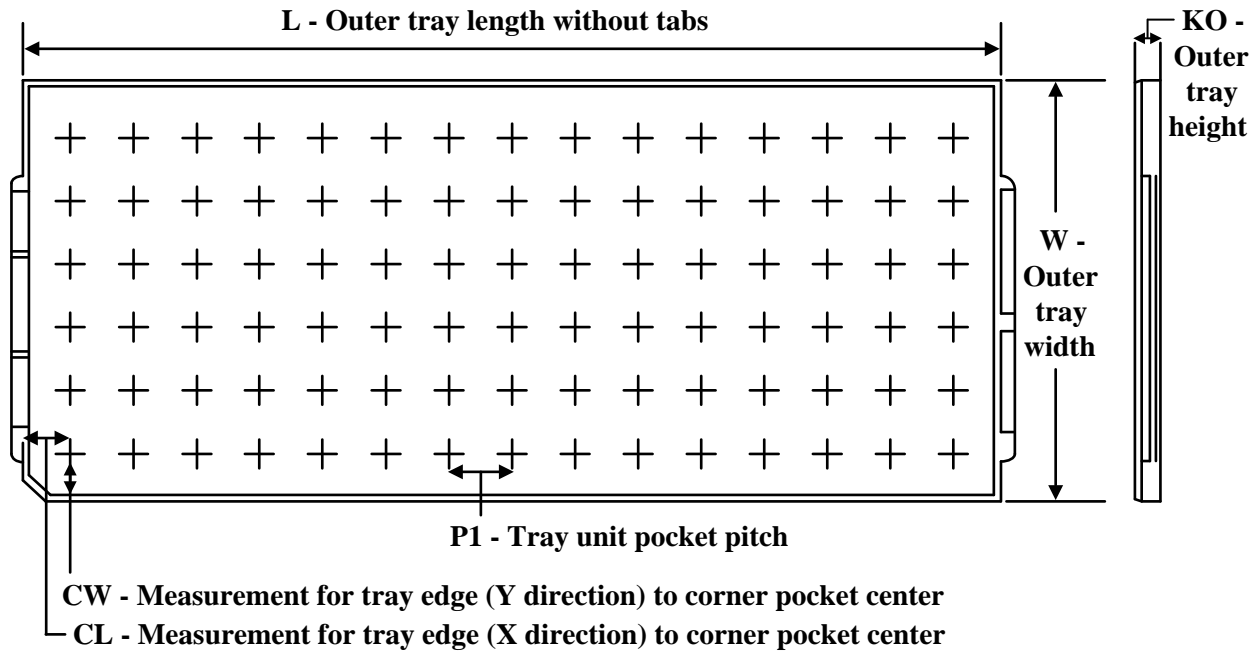
**TRAY**

Chamfer on Tray corner indicates Pin 1 orientation of packed units.

\*All dimensions are nominal

Device	Package Name	Package Type	Pins	SPQ	Unit array matrix	Max temperature (°C)	L (mm)	W (mm)	K0 (µm)	P1 (mm)	CL (mm)	CW (mm)
ADS1294IPAG	PAG	TQFP	64	160	8 x 20	150	315	135.9	7620	15.2	13.1	13
ADS1296IPAG	PAG	TQFP	64	160	8 x 20	150	315	135.9	7620	15.2	13.1	13
ADS1298IPAG	PAG	TQFP	64	160	8 x 20	150	315	135.9	7620	15.2	13.1	13

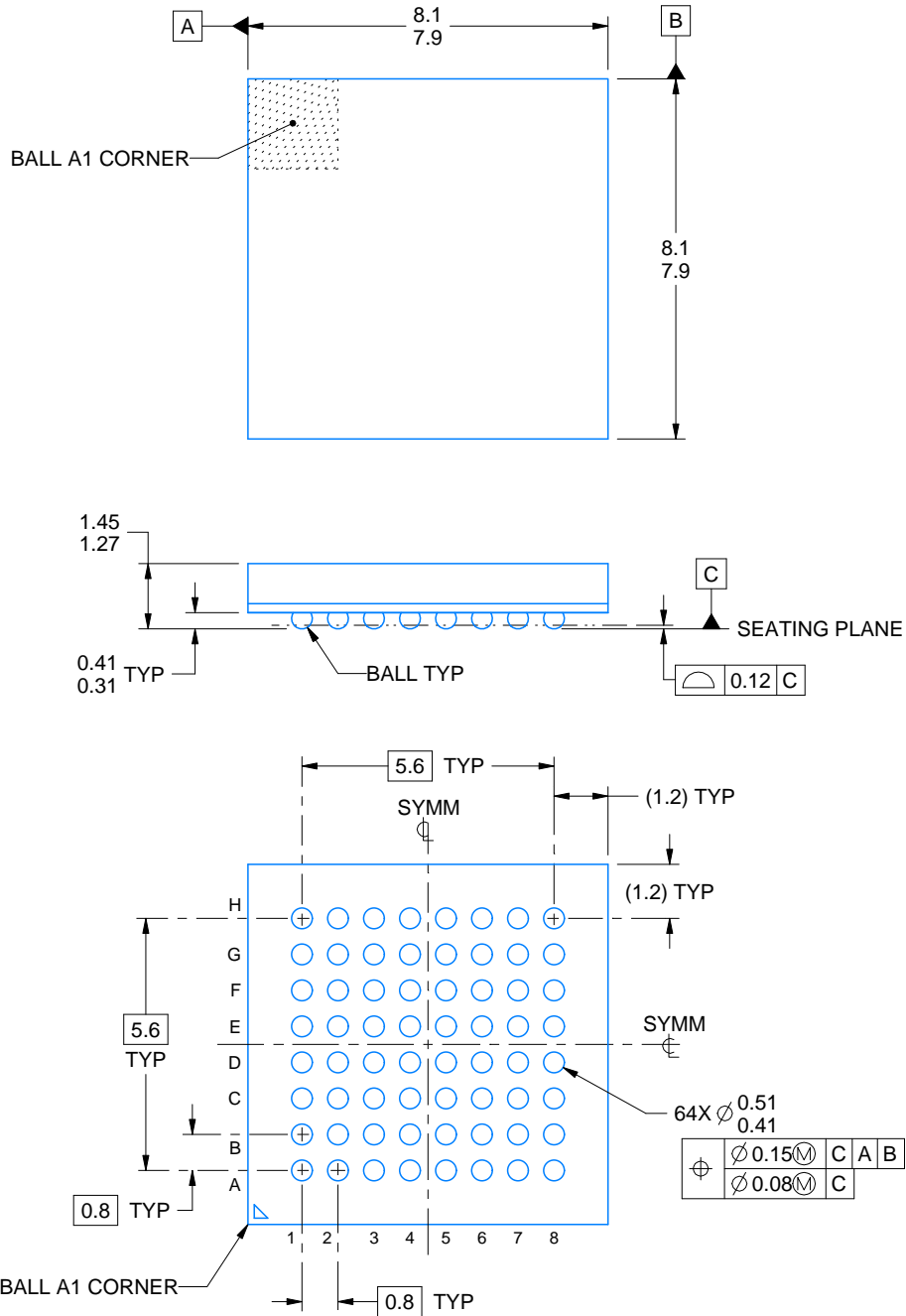
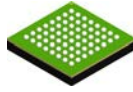

4220377/A 03/2023

NOTES:

1. All linear dimensions are in millimeters. Any dimensions in parenthesis are for reference only. Dimensioning and tolerancing per ASME Y14.5M.
2. This drawing is subject to change without notice.
3. This package is lead-free.

# EXAMPLE BOARD LAYOUT

ZXG0064A

NFBGA - 1.45 mm max height

PLASTIC BALL GRID ARRAY

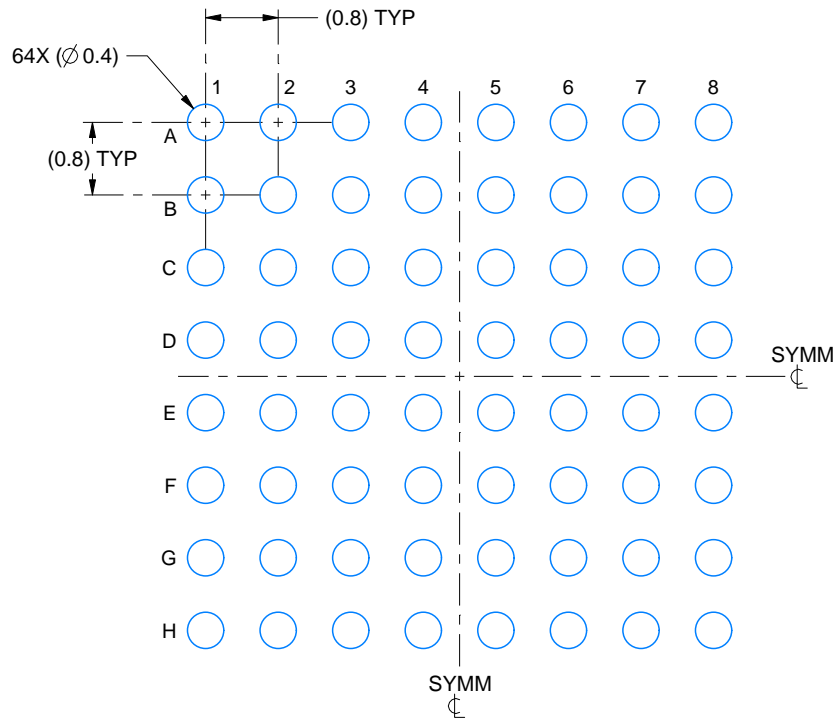

LAND PATTERN EXAMPLE  
EXPOSED METAL SHOWN  
SCALE:12X

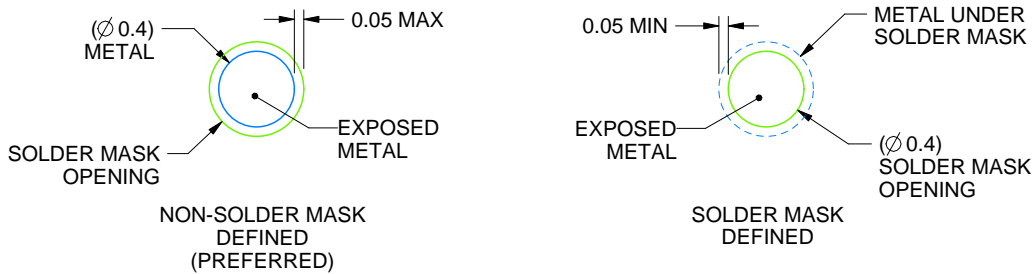

SOLDER MASK DETAILS  
NOT TO SCALE

4220377/A 03/2023

NOTES: (continued)

- Final dimensions may vary due to manufacturing tolerance considerations and also routing constraints. For information, see Texas Instruments literature number SPRAA99 ([www.ti.com/lit/spraa99](http://www.ti.com/lit/spraa99)).

# EXAMPLE STENCIL DESIGN

ZXG0064A

NFBGA - 1.45 mm max height

PLASTIC BALL GRID ARRAY

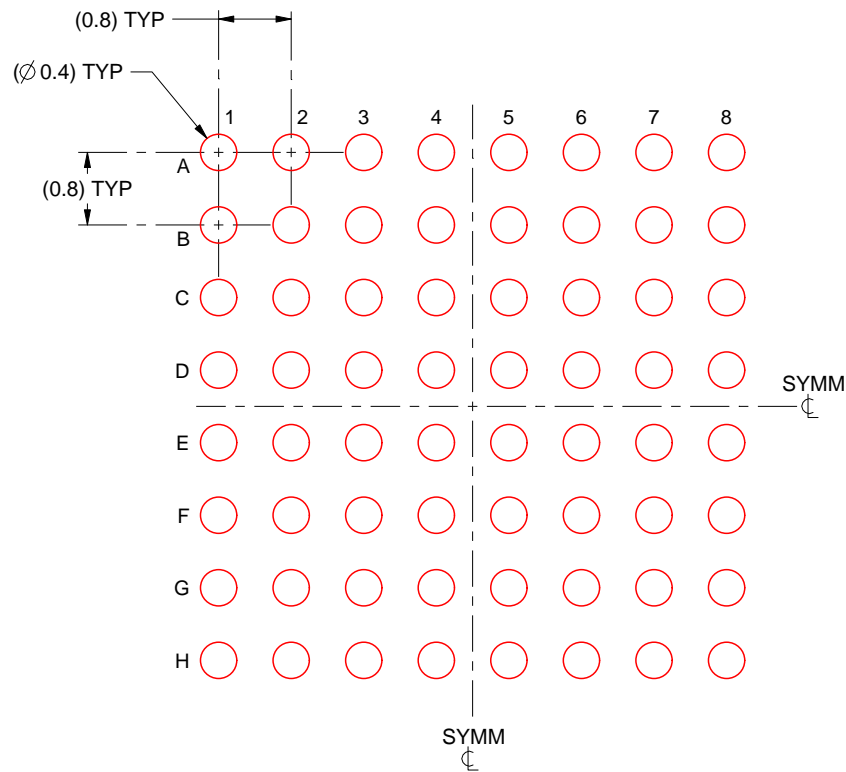

SOLDER PASTE EXAMPLE  
BASED ON 0.125 mm THICK STENCIL  
SCALE:12X

4220377/A 03/2023

NOTES: (continued)

5. Laser cutting apertures with trapezoidal walls and rounded corners may offer better paste release.

PAG (S-PQFP-G64)

PLASTIC QUAD FLATPACK

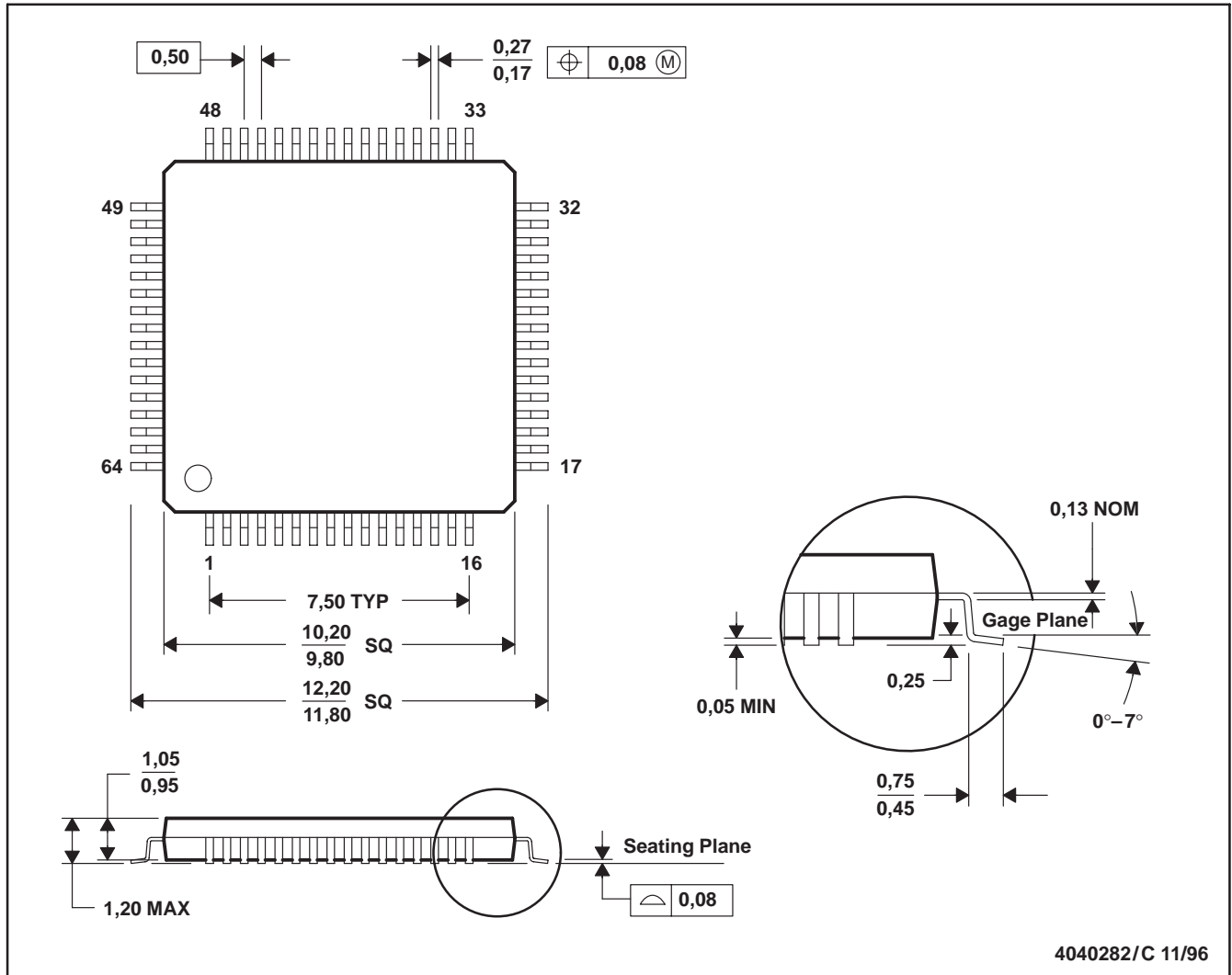

- NOTES: A. All linear dimensions are in millimeters.  
 B. This drawing is subject to change without notice.  
 C. Falls within JEDEC MS-026

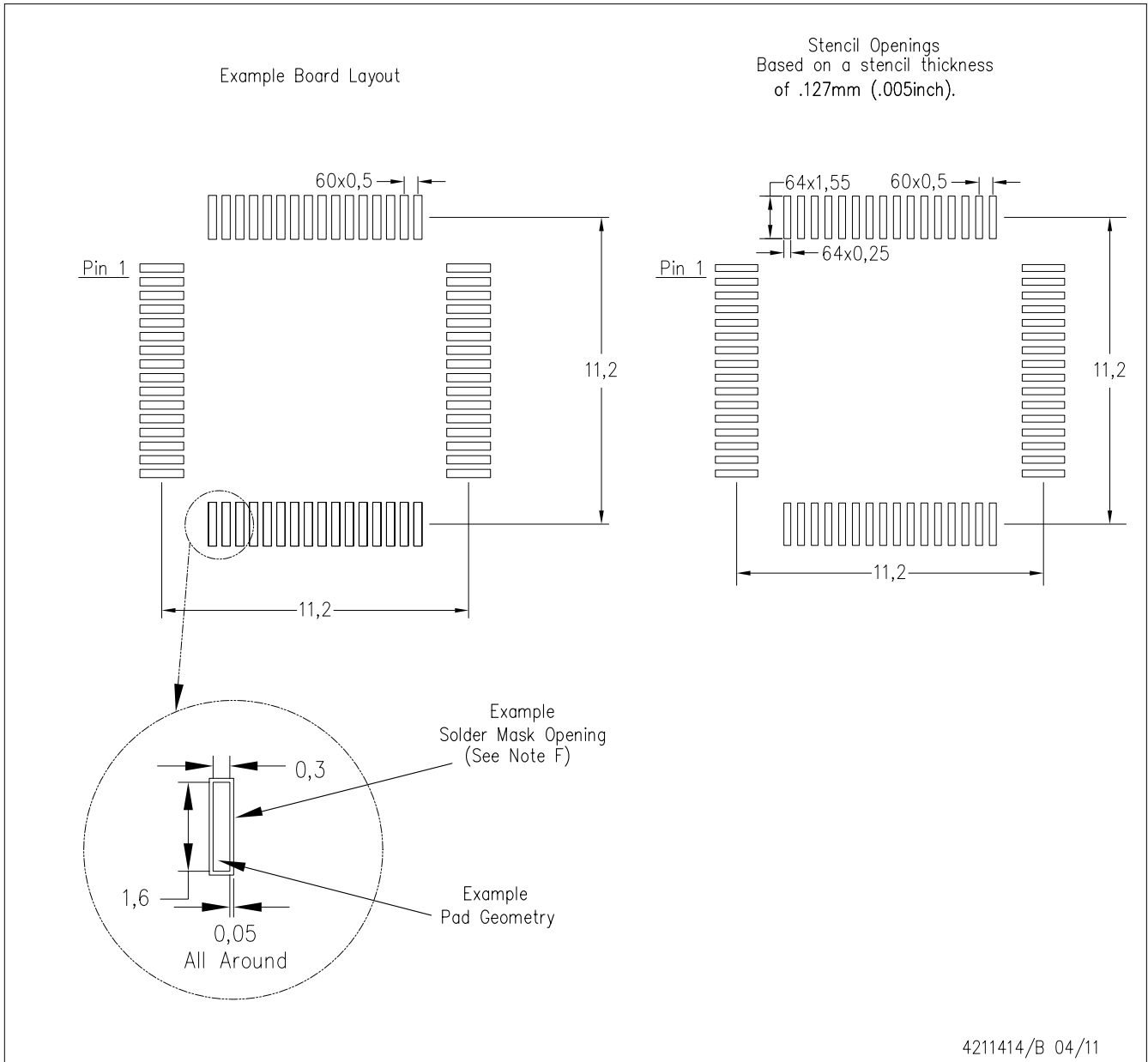

- NOTES:
- A. All linear dimensions are in millimeters.
  - B. This drawing is subject to change without notice.
  - C. Laser cutting apertures with trapezoidal walls and also rounding corners will offer better paste release. Customers should contact their board assembly site for stencil design recommendations. Example stencil design based on a 50% volumetric metal load solder paste. Refer to IPC-7525 for other stencil recommendations.
  - D. Customers should contact their board fabrication site for solder mask tolerances between and around signal pads.

PAG (S-PQFP-G64)

PLASTIC QUAD FLATPACK

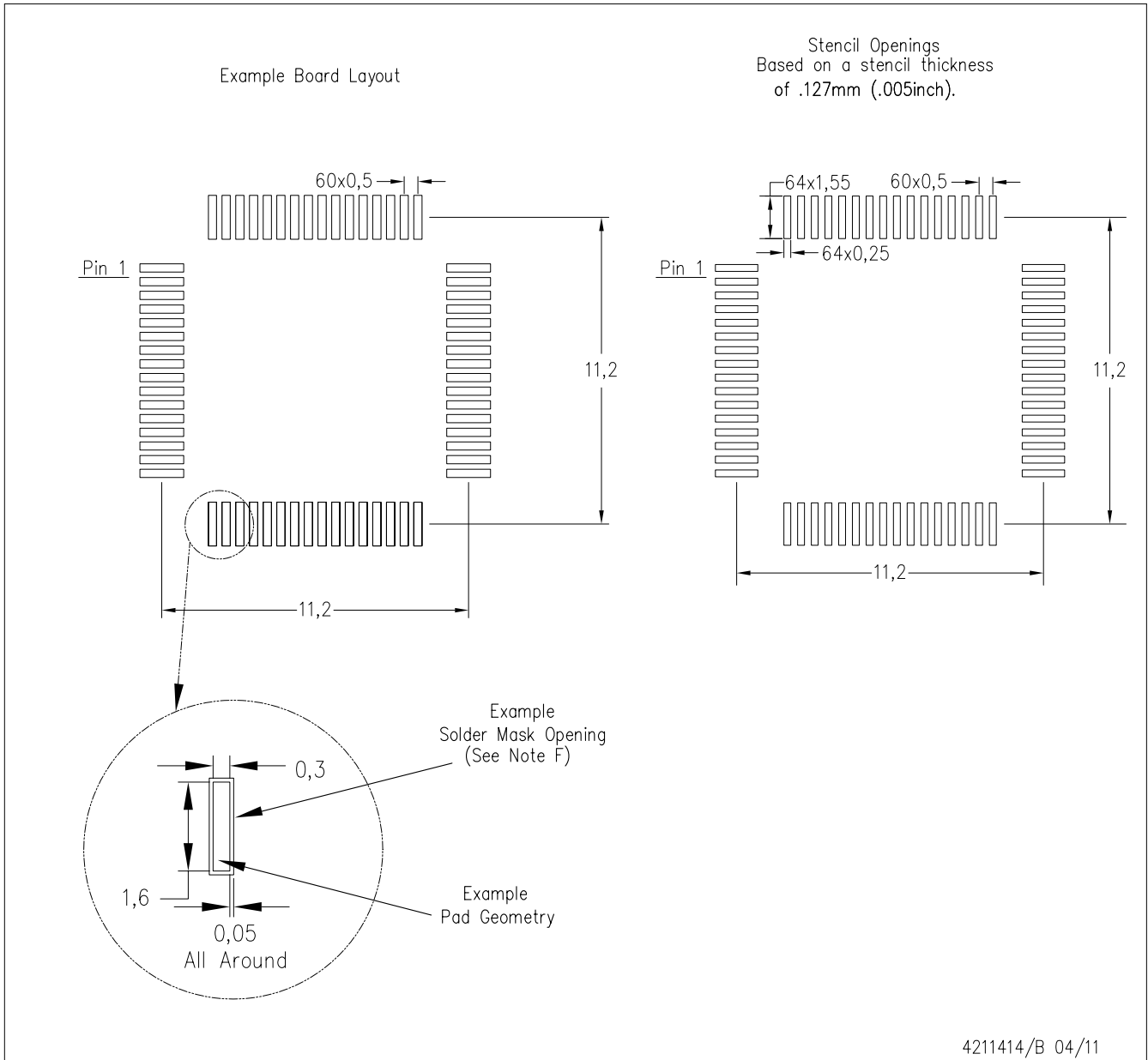

- NOTES:
- A. All linear dimensions are in millimeters.
  - B. This drawing is subject to change without notice.
  - C. Laser cutting apertures with trapezoidal walls and also rounding corners will offer better paste release. Customers should contact their board assembly site for stencil design recommendations. Example stencil design based on a 50% volumetric metal load solder paste. Refer to IPC-7525 for other stencil recommendations.
  - D. Customers should contact their board fabrication site for solder mask tolerances between and around signal pads.

## IMPORTANT NOTICE AND DISCLAIMER

TI PROVIDES TECHNICAL AND RELIABILITY DATA (INCLUDING DATA SHEETS), DESIGN RESOURCES (INCLUDING REFERENCE DESIGNS), APPLICATION OR OTHER DESIGN ADVICE, WEB TOOLS, SAFETY INFORMATION, AND OTHER RESOURCES "AS IS" AND WITH ALL FAULTS, AND DISCLAIMS ALL WARRANTIES, EXPRESS AND IMPLIED, INCLUDING WITHOUT LIMITATION ANY IMPLIED WARRANTIES OF MERCHANTABILITY, FITNESS FOR A PARTICULAR PURPOSE OR NON-INFRINGEMENT OF THIRD PARTY INTELLECTUAL PROPERTY RIGHTS.

These resources are intended for skilled developers designing with TI products. You are solely responsible for (1) selecting the appropriate TI products for your application, (2) designing, validating and testing your application, and (3) ensuring your application meets applicable standards, and any other safety, security, regulatory or other requirements.

These resources are subject to change without notice. TI grants you permission to use these resources only for development of an application that uses the TI products described in the resource. Other reproduction and display of these resources is prohibited. No license is granted to any other TI intellectual property right or to any third party intellectual property right. TI disclaims responsibility for, and you will fully indemnify TI and its representatives against, any claims, damages, costs, losses, and liabilities arising out of your use of these resources.

TI's products are provided subject to [TI's Terms of Sale](#) or other applicable terms available either on [ti.com](https://www.ti.com) or provided in conjunction with such TI products. TI's provision of these resources does not expand or otherwise alter TI's applicable warranties or warranty disclaimers for TI products.

TI objects to and rejects any additional or different terms you may have proposed.

Mailing Address: Texas Instruments, Post Office Box 655303, Dallas, Texas 75265  
Copyright © 2023, Texas Instruments Incorporated

## Looking for pricing, stock, or lifecycle information?

Click below to explore more details on WIN SOURCE:

 [View ADS1298CZXGT on WIN SOURCE](#)

 [Texas Instruments](#) Information

## Optimize Your Supply Chain with WIN SOURCE Solutions

-  Global Sourcing Solution
-  Obsolete Management
-  Cost Control Management
-  Shortage Management
-  Alternative Solution
-  Excess Inventory Management