



**THE DATASHEET OF  
AD5391BCPZ-3**



**FEATURES**
**AD5390:** 16-channel, 14-bit voltage output DAC

**AD5391:** 16-channel, 12-bit voltage output DAC

**AD5392:** 8-channel, 14-bit voltage output DAC

Guaranteed monotonic

INL

 $\pm 1$  LSB max (AD5391)

 $\pm 3$  LSB max (AD5390-5/AD5392-5)

 $\pm 4$  LSB max (AD5390-3/AD5392-3)

On-chip 1.25 V/2.5 V, 10 ppm/°C reference

Temperature range: -40°C to +85°C

Rail-to-rail output amplifier

Power-down mode

Package types

64-lead LFCSP (9 mm × 9 mm)

52-lead LQFP (10 mm × 10 mm)

User interfaces

Serial SPI-, QSPI-, MICROWIRE-, and DSP-compatible

(featuring data readback)

 I<sup>2</sup>C-compatible interface

Integrated functions

channel monitor

simultaneous output update via LDAC

clear function to user-programmable code

amplifier boost mode to optimize slew rate

user-programmable offset and gain adjust

toggle mode enables square wave generation

thermal monitor

Robust 6.5 kV HBM and 2 kV FICDM ESD rating

**APPLICATIONS**

Instrumentation and industrial control

Power amplifier control

Level setting (ATE)

Control systems

Microelectromechanical systems (MEMs)

Variable optical attenuators (VOAs)

Optical transceivers (MSA 300, XFP)

**FUNCTIONAL BLOCK DIAGRAM**

Figure 1.

Rev. F

[Document Feedback](#)

Information furnished by Analog Devices is believed to be accurate and reliable. However, no responsibility is assumed by Analog Devices for its use, nor for any infringements of patents or other rights of third parties that may result from its use. Specifications subject to change without notice. No license is granted by implication or otherwise under any patent or patent rights of Analog Devices. Trademarks and registered trademarks are the property of their respective owners.

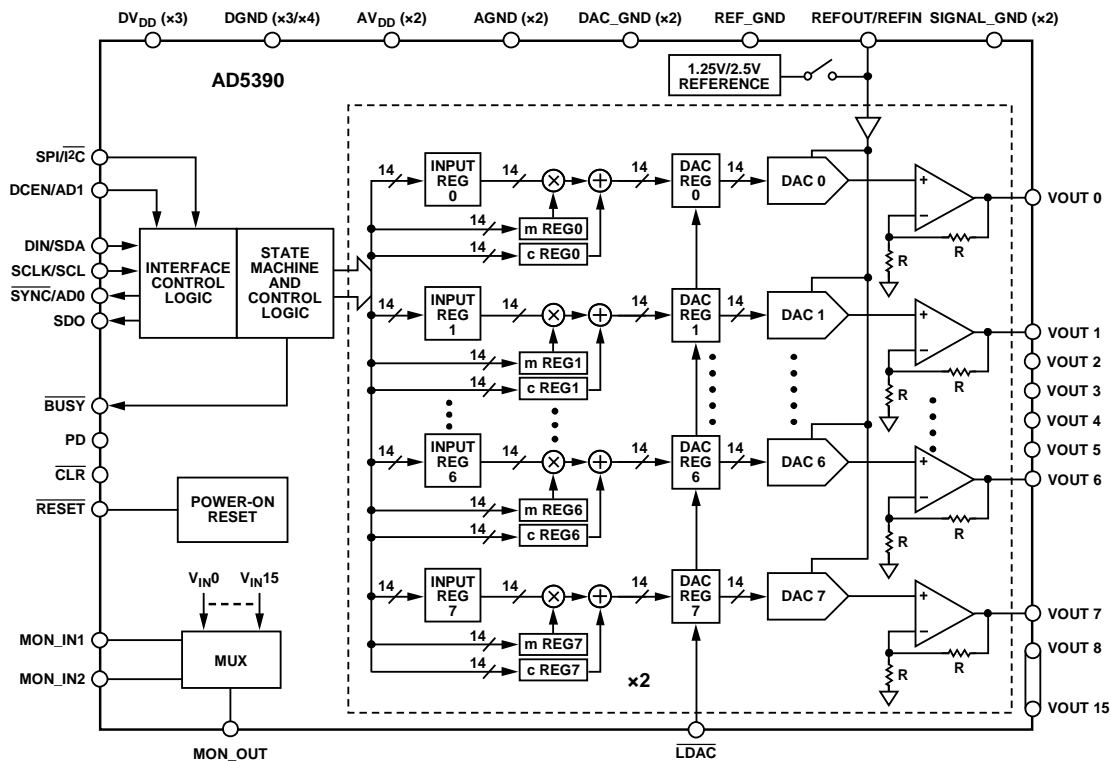
One Technology Way, P.O. Box 9106, Norwood, MA 02062-9106, U.S.A.

Tel: 781.329.4700

©2004–2014 Analog Devices, Inc. All rights reserved.

[Technical Support](#)
[www.analog.com](http://www.analog.com)

03775-001

## TABLE OF CONTENTS

Features .....	1	I <sup>2</sup> C Write Operation .....	28
Applications.....	1	4-Byte Mode.....	28
Functional Block Diagram .....	1	3-Byte Mode.....	29
Revision History .....	3	2-Byte Mode.....	30
General Description .....	4	AD5390/AD5391/AD5392 On-Chip Special Function	
Specifications.....	5	Registers.....	31
AD5390-5/AD5391-5/AD5392-5 Specifications .....	5	Control Register Write.....	33
AD5390-5/AD5391-5/AD5392-5 AC Characteristics.....	7	Hardware Functions.....	35
AD5390-3/AD5391-3/AD5392-3 Specifications .....	8	Reset Function .....	35
AD5390-3/AD5391-3/AD5392-3 AC Characteristics.....	10	Asynchronous Clear Function.....	35
Timing Characteristics.....	11	BUSY and LDAC Functions.....	35
Serial SPI-, QSPI-, MICROWIRE-, and DSP-Compatible		Power-On Reset .....	35
Interface .....	11	Power-Down .....	35
I <sup>2</sup> C Serial Interface.....	13	Microprocessor Interfacing.....	35
Absolute Maximum Ratings.....	14	Application Information.....	37
ESD Caution.....	14	Power Supply Decoupling .....	37
Pin Configuratons and Function Descriptions .....	15	Power Supply Sequencing .....	38
Terminology .....	18	Typical Configuration Circuit .....	39
Typical Performance Characteristics .....	19	AD5390/AD5391/AD5392 Monitor Function.....	40
Functional Description .....	23	Toggle Mode Function.....	40
DAC Architecture.....	23	Thermal Monitor Function.....	40
Data Decoding .....	24	Outline Dimensions .....	42
Interfaces.....	25	Ordering Guide .....	43
DSP-, SPI-, and MICROWIRE-Compatible Serial Interface.....	25		
I <sup>2</sup> C Serial Interface.....	27		

**REVISION HISTORY****6/14—Rev. E to Rev. F**

Deleted Table 1; Renumbered Sequentially .....	4
Changed AD5390-3/AD5391-3/AD5392-3 Input Current from $\pm 10 \mu\text{A}$ (max) to $\pm 1 \mu\text{A}$ (max); Table 3 .....	8
Changes to Table 5 .....	11
Changes to Soft Reset Section .....	31
Changes to Reset Function Section .....	35
Replaced ADSP2101 with ADSP-BF527 .....	36
Added Power Supply Sequencing Section .....	38
Changes to Ordering Guide.....	43

**6/12—Rev. D to Rev. E**

Changes to Table 1 .....	4
Change to Accuracy Parameter, Gain Error, Table 2.....	5
Change to Accuracy Parameter, Gain Error, Table 4.....	8
Added Exposed Pad Notation to Figure 7 and Figure 8 .....	15

**5/12—Rev. C to Rev. D**

Changes to Product Title and Features Section .....	1
Changes to Table 2 .....	4
Changes to Table 3 .....	6
Changes to Table 4 .....	7
Changes to Table 5 .....	9
Changes to Table 6 .....	10
Changes to Table 8 .....	13
Changes to Figure 8 and Figure 10 .....	14
Changes to Table 9 .....	16
Changes to Figure 17, Figure 18, Figure 19, And Figure 22 .....	19
Changes to Figure 23, Figure 24, Figure 25, and Figure 26 .....	20
Changes to Table 26 .....	32
Changes to Ordering Guide.....	40

**1/09—Rev. B to Rev. C**

Updated Format .....	Universal
Changes to Figure 33 .....	27
Added Figure 34 and Renumbered Sequentially .....	27
Changes to Figure 34 .....	28
Changes to Table 28 .....	33
Change order of Figure 41 and Figure 42 .....	36
Changes to Toggle Mode Function Section.....	37

**3/06—Rev. A to Rev. B**

Changes to Figure 1 .....	1
Changes to Table 9 .....	14
Changes to Table 12 and Table 15.....	23
Updated Outline Dimensions.....	39
Changes to Ordering Guide.....	40

**10/04—Rev. 0 to Rev. A**

Changes to Features .....	1
Changes to Table 1 .....	3
Changes to Table 2 .....	4
Changes to Table 3 .....	6
Changes to Table 4 .....	7
Changes to Figure 36 .....	35
Changes to Figure 37 .....	36
Changes to Figure 38 .....	36
Changes to Ordering Guide.....	41

**4/04—Revision 0: Initial Version**

## GENERAL DESCRIPTION

The [AD5390/AD5391](#) are complete single-supply, 16-channel, 14-bit and 12-bit DACs, respectively. The [AD5392](#) is a complete single-supply, 8-channel, 14-bit DAC. The devices are available in either a 64-lead LFCSP or a 52-lead LQFP. All channels have an on-chip output amplifier with rail-to-rail operation. All devices include an internal 1.25/2.5 V, 10 ppm/°C reference, an on-chip channel monitor function that multiplexes the analog outputs to a common MON\_OUT pin for external monitoring, and an output amplifier boost mode that optimizes the output amplifier slew rate.

The [AD5390/AD5391/AD5392](#) contain a 3-wire serial interface with interface speeds in excess of 30 MHz that are compatible with SPI®, QSPI™, MICROWIRE™, and DSP interface standards and an I<sup>2</sup>C-compatible interface supporting a 400 kHz data transfer rate.

An input register followed by a DAC register provides double-buffering, allowing DAC outputs to be updated independently or simultaneously using the LDAC input. Each channel has a programmable gain and offset adjust register, letting the user fully calibrate any DAC channel.

Power consumption is typically 0.25 mA per channel.

## SPECIFICATIONS

## AD5390-5/AD5391-5/AD5392-5 SPECIFICATIONS

$AV_{DD} = 4.5\text{ V to }5.5\text{ V}$ ;  $DV_{DD} = 2.7\text{ V to }5.5\text{ V}$ ;  $AGND = DGND = 0\text{ V}$ ;  $REFIN = 2.5\text{ V}$  external. All specifications  $T_{MIN}$  to  $T_{MAX}$ , unless otherwise noted.

Table 1.

Parameter	AD5390-5 <sup>1</sup> AD5392-5 <sup>1</sup>	AD5391-5 <sup>1</sup>	Unit	Test Conditions/Comments
<b>ACCURACY</b>				
Resolution	14	12	Bits	
Relative Accuracy	±3	±1	LSB max	
Differential Nonlinearity	-1/+2	±1	LSB max	Guaranteed monotonic over temperature
Zero-Scale Error	4	4	mV max	
Offset Error	±4	±4	mV max	Measured at Code 32 in the linear region (AD5390-5/AD5391-5); measured at Code 8 in the linear region (AD5391-5)
Offset Error TC	±5	±5	μV/°C typ	
Gain Error	±0.05	±0.05	% FSR max	At 25°C $T_{MIN}$ to $T_{MAX}$
Gain Temperature Coefficient <sup>2</sup>	±0.06	±0.06	% FSR max	
DC Crosstalk <sup>2</sup>	2	2	ppm FSR/°C typ	
	1	1	LSB max	
<b>REFERENCE INPUT/OUTPUT</b>				
Reference Input <sup>2</sup>				
Reference Input Voltage	2.5	2.5	V	±1% for specified performance, $AV_{DD} = 2 \times REFIN + 50\text{ mV}$
DC Input Impedance	1	1	MΩ min	Typically 100 MΩ
Input Current	±1	±1	μA max	Typically ±30 nA
Reference Range	1 V to $AV_{DD}/2$	1 V to $AV_{DD}/2$	V min/max	
Reference Output <sup>3</sup>				Enabled via internal/external bit in control register; REF select bit in control register selects the reference voltage
Output Voltage	2.495/2.505	2.495/2.505	V min/max	At ambient, optimized for 2.5 V operation
	1.22/1.28	1.22/1.28	V min/max	At ambient when 1.25 V reference is selected
Reference TC	±10	±10	ppm max	Temperature range: 25°C to 85°C
	±15	±15	ppm max	Temperature range: -40°C to +85°C
Output Impedance	800	800	Ω typ	
<b>OUTPUT CHARACTERISTICS<sup>2</sup></b>				
Output Voltage Range <sup>4</sup>	0/ $AV_{DD}$	0/ $AV_{DD}$	V min/max	
Short-Circuit Current	40	40	mA max	
Load Current	±1	±1	mA max	
Capacitive Load Stability				
$R_L = \infty$	200	200	pF max	
$R_L = 5\text{ k}\Omega$	1000	1000	pF max	
DC Output Impedance	0.6	0.6	Ω max	
<b>MONITOR OUTPUT PIN</b>				
Output Impedance	1000	1000	Ω typ	
Three-State Leakage Current	100	100	nA typ	
<b>LOGIC INPUTS<sup>2</sup></b>				
$V_{IH}$ , Input High Voltage	2	2	V min	$DV_{DD} = 2.7\text{ V to }5.5\text{ V}$
$V_{IL}$ , Input Low Voltage				
$DV_{DD} > 3.6\text{ V}$	0.8	0.8	V max	
$DV_{DD} \leq 3.6\text{ V}$	0.6	0.6	V max	
Input Current	±10	±10	μA max	Total for all pins, $T_A = T_{MIN}$ to $T_{MAX}$
Pin Capacitance	10	10	pF max	

Parameter	AD5390-5 <sup>1</sup> AD5392-5 <sup>1</sup>	AD5391-5 <sup>1</sup>	Unit	Test Conditions/Comments
LOGIC INPUTS (SCL, SDA Only)				
V <sub>IH</sub> , Input High Voltage	0.7 × DV <sub>DD</sub>	0.7 × DV <sub>DD</sub>	V min	SMBus-compatible at DV <sub>DD</sub> < 3.6 V
V <sub>IL</sub> , Input Low Voltage	0.3 × DV <sub>DD</sub>	0.3 × DV <sub>DD</sub>	V max	SMBus-compatible at DV <sub>DD</sub> < 3.6 V
I <sub>IN</sub> , Input Leakage Current	±1	±1	μA max	
V <sub>HYST</sub> , Input Hysteresis	0.05 × DV <sub>DD</sub>	0.05 × DV <sub>DD</sub>	V min	
C <sub>IN</sub> , Input Capacitance	8	8	pF typ	
Glitch Rejection	50	50	ns max	Input filtering suppresses noise spikes of <50 ns
LOGIC OUTPUTS (BUSY, SDO) <sup>2</sup>				
Output Low Voltage	0.4	0.4	V max	DV <sub>DD</sub> = 5 V ± 10%, sinking 200 μA
Output High Voltage	DV <sub>DD</sub> - 1	DV <sub>DD</sub> - 1	V min	DV <sub>DD</sub> = 5 V ± 10%, SDO only, sourcing 200 μA
Output Low Voltage	0.4	0.4	V max	DV <sub>DD</sub> = 2.7 V to 3.6 V, sinking 200 μA
Output High Voltage	DV <sub>DD</sub> - 0.5	DV <sub>DD</sub> - 0.5	V min	DV <sub>DD</sub> = 2.7 V to 3.6 V SDO only, sourcing 200 μA
High Impedance Leakage Current	±1	±1	μA max	
High Impedance Output Capacitance	5	5	pF typ	
LOGIC OUTPUT (SDA) <sup>2</sup>				
V <sub>OL</sub> , Output Low Voltage	0.4	0.4	V max	I <sub>SINK</sub> = 3 mA
	0.6	0.6	V max	I <sub>SINK</sub> = 6 mA
Three-State Leakage Current	±1	±1	μA max	
Three-State Output Capacitance	8	8	pF typ	
POWER REQUIREMENTS				
AV <sub>DD</sub>	4.5/5.5	4.5/5.5	V min/max	
DV <sub>DD</sub>	2.7/5.5	2.7/5.5	V min/max	
Power Supply Sensitivity <sup>2</sup>				
ΔMidscale/ΔAV <sub>DD</sub>	-85	-85	dB typ	
AI <sub>DD</sub>	0.375	0.375	mA/channel max	Outputs unloaded, boost off, 0.25 mA/channel typ
AI <sub>DD</sub>	0.475	0.475	mA/channel max	Outputs unloaded, boost on, 0.325 mA/channel typ
DI <sub>DD</sub>	1	1	mA max	V <sub>IH</sub> = DV <sub>DD</sub> , V <sub>IL</sub> = DGND
AI <sub>DD</sub> (Power-Down)	20	20	μA max	Typically 100 nA
DI <sub>DD</sub> (Power-Down)	20	20	μA max	Typically 1 μA
Power Dissipation	35	35	mW max	AD5390/AD5391 with outputs unloaded, AV <sub>DD</sub> = DV <sub>DD</sub> = 5 V, boost off
	20	20	mW max	AD5392 with outputs unloaded, AV <sub>DD</sub> = DV <sub>DD</sub> = 5 V, boost off

<sup>1</sup> The AD5390-5/AD5391-5/AD5392-5 are calibrated with a 2.5 V reference. Temperature range for all versions: -40°C to +85°C.

<sup>2</sup> Guaranteed by characterization, not production tested.

<sup>3</sup> Programmable either to 1.25 V typical or 2.5 V typical via the AD5390/AD5391/AD5392 control register. Operating the AD5390-5/AD5391-5/AD5392-5 with a reference of 1.25 V leads to a degradation in performance accuracy.

<sup>4</sup> Accuracy guaranteed from V<sub>OUT</sub> = 10 mV to AV<sub>DD</sub> - 50 mV.

**AD5390-5/AD5391-5/AD5392-5 AC CHARACTERISTICS**

$AV_{DD} = 4.5\text{ V to }5.5\text{ V}$ ;  $DV_{DD} = 2.7\text{ V to }5.5\text{ V}$ ;  $AGND = DGND = 0\text{ V}$ .

**Table 2.**

Parameter	All <sup>1</sup>	Unit	Test Conditions/Comments
<b>DYNAMIC PERFORMANCE</b>			
Output Voltage Settling Time			¼ scale to ¾ scale change settling to ±1 LSB
AD5390/AD5392	3	µs typ	Boost mode off, CR11 = 0
	8	µs max	Boost mode off, CR11 = 0
AD5391	3	µs typ	Boost mode off, CR11 = 0
	8	µs max	Boost mode off, CR11 = 0
Slew rate <sup>2</sup>	2.5	V/µs typ	Boost mode on
	1.5	V/µs typ	Boost mode off
Digital-to-Analog Glitch Energy	12	nV-s typ	
Glitch Impulse Peak Amplitude	15	mV typ	
Channel-to-Channel Isolation	100	dB typ	See the Terminology section
DAC-to-DAC Crosstalk	1	nV-s typ	See the Terminology section
Digital Crosstalk	0.8	nV-s typ	
Digital Feedthrough	0.1	nV-s typ	Effect of input bus activity on DAC output under test
Output Noise (0.1 Hz to 10 Hz)	15	µV p-p typ	External reference midscale loaded to DAC
	40	µV p-p typ	Internal reference midscale loaded to DAC
Output Noise Spectral Density			
@ 1 kHz	150	nV/(Hz) <sup>1/2</sup> typ	
@ 10 kHz	100	nV/(Hz) <sup>1/2</sup> typ	

<sup>1</sup> Guaranteed by characterization, not production tested.

<sup>2</sup> The slew rate can be adjusted via the current boost control bit in the DAC control register.

## AD5390-3/AD5391-3/AD5392-3 SPECIFICATIONS

$AV_{DD} = 2.7\text{ V to }3.6\text{ V}$ ;  $DV_{DD} = 2.7\text{ V to }5.5\text{ V}$ ;  $AGND = DGND = 0\text{ V}$ ;  $REFIN = 1.25\text{ V external}$ . All specifications  $T_{MIN}$  to  $T_{MAX}$ , unless otherwise noted.

Table 3.

Parameter	AD5390-3 <sup>1</sup> AD5392-3 <sup>1</sup>	AD5391-3 <sup>1</sup>	Unit	Test Conditions/Comments
<b>ACCURACY</b>				
Resolution	14	12	Bits	Guaranteed monotonic over temperature  Measured at code 64 in the linear region  At 25°C $T_{MIN}$ to $T_{MAX}$
Relative Accuracy	±4	±1	LSB max	
Differential Nonlinearity	-1/+2	±1	LSB max	
Zero-Scale Error	4	4	mV max	
Offset Error	±4	±4	mV max	
Offset Error TC	±5	±5	μV/°C typ	
Gain Error	±0.05	±0.05	% FSR max	
Gain Temperature Coefficient <sup>2</sup>	±0.1	±0.1	% FSR max	
DC Crosstalk	2	2	ppm FSR/°C typ	
	1	1	LSB max	
<b>REFERENCE INPUT/OUTPUT</b>				
Reference Input <sup>2</sup>				
Reference Input Voltage	1.25	1.25	V	±1% for specified performance
DC Input Impedance	1	1	MΩ min	Typically 100 MΩ
Input Current	±1	±1	μA max	Typically ±30 nA
Reference Range	1 V to $AV_{DD}/2$	1 V to $AV_{DD}/2$	V min/max	
Reference Output <sup>3</sup>				Enabled via internal/external bit in control register; REF select bit in control register selects the reference voltage
Output Voltage	1.245/1.255	1.245/1.255	V min/max	At ambient, optimized for 1.25 V operation
Reference TC	2.47/2.53	2.47/2.53	V min/max	At ambient when 2.5 V reference is selected
Output Impedance	±10	±10	ppm max	Temperature range: 25°C to 85°C
	±15	±15	ppm max	Temperature range: -40°C to +85°C
	800	800	Ω typ	
<b>OUTPUT CHARACTERISTICS<sup>2</sup></b>				
Output Voltage Range <sup>4</sup>	0/ $AV_{DD}$	0/ $AV_{DD}$	V min/max	
Short-Circuit Current	40	40	mA max	
Load Current	±1	±1	mA max	
Capacitive Load Stability				
$R_L = \infty$	200	200	pF max	
$R_L = 5\text{ k}\Omega$	1000	1000	pF max	
DC Output Impedance	0.6	0.6	Ω max	
<b>MONITOR OUTPUT PIN<sup>2</sup></b>				
Output Impedance	1000	1000	Ω typ	
Three-State Leakage Current	100	100	nA typ	
<b>LOGIC INPUTS<sup>2</sup></b>				
$V_{IH}$ , Input High Voltage	2	2	V min	$DV_{DD} = 2.7\text{ V to }5.5\text{ V}$
$V_{IL}$ , Input Low Voltage				
$DV_{DD} > 3.6\text{ V}$	0.8	0.8	V max	
$DV_{DD} \leq 3.6\text{ V}$	0.6	0.6	V max	
Input Current	±1	±1	μA max	Total for all pins. $T_A = T_{MIN}$ to $T_{MAX}$
Pin Capacitance	10	10	pF max	

Parameter	AD5390-3 <sup>1</sup> AD5392-3 <sup>1</sup>	AD5391-3 <sup>1</sup>	Unit	Test Conditions/Comments
Logic Inputs (SCL, SDA Only)				
V <sub>IH</sub> , Input High Voltage	0.7 × DV <sub>DD</sub>	0.7 × DV <sub>DD</sub>	V min	SMBus-compatible at DV <sub>DD</sub> < 3.6 V
V <sub>IL</sub> , Input Low Voltage	0.3 × DV <sub>DD</sub>	0.3 × DV <sub>DD</sub>	V max	SMBus-compatible at DV <sub>DD</sub> < 3.6 V
I <sub>IN</sub> , Input Leakage Current	±1	±1	μA max	
V <sub>HYST</sub> , Input Hysteresis	0.05 × DV <sub>DD</sub>	0.05 × DV <sub>DD</sub>	V min	
Glitch Rejection	50	50	ns max	Input filtering suppresses noise spikes <50 ns
Logic Outputs ( $\overline{\text{BUSY}}$ , SDO) <sup>2</sup>				
Output Low Voltage	0.4	0.4	V max	DV <sub>DD</sub> = 2.7 V to 5.5 V, sinking 200 μA
Output High Voltage	DV <sub>DD</sub> - 0.5	DV <sub>DD</sub> - 0.5	V min	DV <sub>DD</sub> = 2.7 V to 3.6 V, SDO only, sourcing 200 μA
	DV <sub>DD</sub> - 0.1	DV <sub>DD</sub> - 0.1	V min	DV <sub>DD</sub> = 4.5 V to 5.5 V, SDO only, sourcing 200 μA
High Impedance Leakage Current	±1	±1	μA max	
High Impedance Output Capacitance	5	5	pF typ	
Logic Output (SDA) <sup>2</sup>				
V <sub>OL</sub> , Output Low Voltage	0.4	0.4	V max	I <sub>SINK</sub> = 3 mA
	0.6	0.6	V max	I <sub>SINK</sub> = 6 mA
Three-State Leakage Current	±1	±1	μA max	
Three-State Output Capacitance	8	8	pF typ	
<b>POWER REQUIREMENTS</b>				
AV <sub>DD</sub>	2.7/3.6	2.7/3.6	V min/max	
DV <sub>DD</sub>	2.7/5.5	2.7/5.5	V min/max	
Power Supply Sensitivity <sup>2</sup>				
ΔMidscale/ΔAV <sub>DD</sub>	-85	-85	dB typ	
AI <sub>DD</sub>	0.375	0.375	mA/channel max	Outputs unloaded, boost off, 0.25 mA/channel typ
AI <sub>DD</sub>	0.475	0.475	mA/channel max	Outputs unloaded, boost on, 0.325 mA/channel typ
DI <sub>DD</sub>	1	1	mA max	V <sub>IH</sub> = DV <sub>DD</sub> , V <sub>IL</sub> = DGND
AI <sub>DD</sub> (Power-Down)	20	20	μA max	Typically 100 nA
DI <sub>DD</sub> (Power-Down)	20	20	μA max	Typically 1 μA
Power Dissipation	21	21	mW max	AD5390/AD5391 with outputs unloaded, AV <sub>DD</sub> = DV <sub>DD</sub> = 3 V, boost off
	12	12	mW max	AD5392 with outputs unloaded, AV <sub>DD</sub> = DV <sub>DD</sub> = 3 V, boost off

<sup>1</sup> The AD5390-3/AD5391-3/AD5392-3 are calibrated with a 1.25 V reference. Temperature range for all versions: -40°C to +85°C.

<sup>2</sup> Guaranteed by characterization, not production tested.

<sup>3</sup> Programmable either to 1.25 V typical or 2.5 V typical via the AD5390/AD5391/AD5392 control register. Operating the AD5390-3/AD5391-3/AD5392-3 with a reference of 2.5 V leads to a degradation in performance accuracy.

<sup>4</sup> Accuracy guaranteed from V<sub>OUT</sub> = 39 mV to AV<sub>DD</sub> - 50 mV.

**AD5390-3/AD5391-3/AD5392-3 AC CHARACTERISTICS**

$AV_{DD} = 2.7\text{ V to }3.6\text{ V}$ ;  $DV_{DD} = 2.7\text{ V to }5.5\text{ V}$ ;  $AGND = DGND = 0\text{ V}$ ;  $C_L = 200\text{ pF to AGND}$ .

**Table 4.**

Parameter	All <sup>1</sup>	Unit	Test Conditions/Comments
<b>DYNAMIC PERFORMANCE</b>			
Output Voltage Settling Time			¼ scale to ¾ scale change settling to ±1 LSB
AD5390/AD5392	3	µs typ	Boost mode off, CR11 = 0
	8	µs max	Boost mode off, CR11 = 0
AD5391	3	µs typ	Boost mode off, CR11 = 0
	8	µs max	Boost mode on, CR11 = 1
Slew Rate <sup>2</sup>	2.5	V/µs typ	Boost mode on
	1.5	V/µs typ	Boost mode off, CR11 = 0
Digital-to-Analog Glitch Energy	12	nV-s typ	
Glitch Impulse Peak Amplitude	15	mV typ	
Channel-to-Channel Isolation	100	dB typ	See the Terminology section
DAC-to-DAC Crosstalk	1	nV-s typ	See the Terminology section
Digital Crosstalk	0.8	nV-s typ	
Digital Feedthrough	0.1	nV-s typ	Effect of input bus activity on DAC output under test
<b>OUTPUT NOISE (0.1 Hz to 10 Hz)</b>			
	15	µV p-p typ	External reference midscale loaded to DAC
	40	µV p-p typ	Internal reference midscale loaded to DAC
Output Noise Spectral Density			
@ 1 kHz	150	nV/(Hz) <sup>1/2</sup> typ	
@ 10 kHz	100	nV/(Hz) <sup>1/2</sup> typ	

<sup>1</sup> Guaranteed by design and characterization, not production tested.

<sup>2</sup> The slew rate can be programmed via the current boost control bit in the [AD5390/AD5391/AD5392](#) control registers.

# TIMING CHARACTERISTICS

## SERIAL SPI-, QSPI-, MICROWIRE-, AND DSP-COMPATIBLE INTERFACE

DV<sub>DD</sub> = 2 V to 5.5 V; AV<sub>DD</sub> = 2.7 V to 5.5 V; AGND = DGND = 0 V. All specifications T<sub>MIN</sub> to T<sub>MAX</sub>, unless otherwise noted.

Table 5. 3-Wire Serial Interface<sup>1</sup>

Parameter <sup>2,3</sup>	Limit at T <sub>MIN</sub> , T <sub>MAX</sub>	Unit	Description
t <sub>1</sub>	33	ns min	SCLK cycle time
t <sub>2</sub>	13	ns min	SCLK high time
t <sub>3</sub>	13	ns min	SCLK low time
t <sub>4</sub>	13	ns min	$\overline{\text{SYNC}}$ falling edge to SCLK falling edge setup time
t <sub>5</sub> <sup>4</sup>	13	ns min	24 <sup>th</sup> SCLK falling edge to $\overline{\text{SYNC}}$ falling edge
t <sub>6</sub> <sup>4</sup>	33	ns min	Minimum $\overline{\text{SYNC}}$ low time
t <sub>7</sub>	10	ns min	Minimum $\overline{\text{SYNC}}$ high time
t <sub>7</sub>	140	ns min	Minimum $\overline{\text{SYNC}}$ high time in readback mode
t <sub>8</sub>	5	ns min	Data setup time
t <sub>9</sub>	4.5	ns min	Data hold time
t <sub>10</sub> <sup>4</sup>	36	ns max	24 <sup>th</sup> SCLK falling edge to $\overline{\text{BUSY}}$ falling edge
t <sub>11</sub>	670	ns max	$\overline{\text{BUSY}}$ pulse width low (single channel update)
t <sub>12</sub> <sup>4</sup>	20	ns min	24 <sup>th</sup> SCLK falling edge to $\overline{\text{LDAC}}$ falling edge
t <sub>13</sub>	20	ns min	$\overline{\text{LDAC}}$ pulse width low
t <sub>14</sub>	100/2000	ns min/max	$\overline{\text{BUSY}}$ rising edge to DAC output response time
t <sub>15</sub>	0	ns min	$\overline{\text{BUSY}}$ rising edge to $\overline{\text{LDAC}}$ falling edge
t <sub>16</sub>	100	ns min	$\overline{\text{LDAC}}$ falling edge to DAC output response time
t <sub>17</sub>	3	$\mu\text{s typ}$	DAC output settling time, AD5390/AD5391/AD5392; boost mode off
t <sub>18</sub>	20	ns min	$\overline{\text{CLR}}$ pulse width low
t <sub>19</sub>	40	$\mu\text{s max}$	$\overline{\text{CLR}}$ pulse activation time
t <sub>20</sub> <sup>5</sup>	20	ns max	SCLK rising edge to SDO valid
t <sub>21</sub> <sup>4</sup>	5	ns min	SCLK falling edge to $\overline{\text{SYNC}}$ rising edge
t <sub>22</sub> <sup>4</sup>	8	ns min	$\overline{\text{SYNC}}$ rising edge to SCLK rising edge
t <sub>23</sub> <sup>4</sup>	20	ns min	$\overline{\text{SYNC}}$ rising edge to $\overline{\text{LDAC}}$ falling edge

<sup>1</sup> Guaranteed by design and characterization, not production tested.

<sup>2</sup> All input signals are specified with tr = tf = 5 ns (10% to 90% of V<sub>CC</sub>) and timed from a voltage level of 1.2 V.

<sup>3</sup> See Figure 2, Figure 3, Figure 4, and Figure 5.

<sup>4</sup> Standalone mode only.

<sup>5</sup> Daisy-chain mode only.

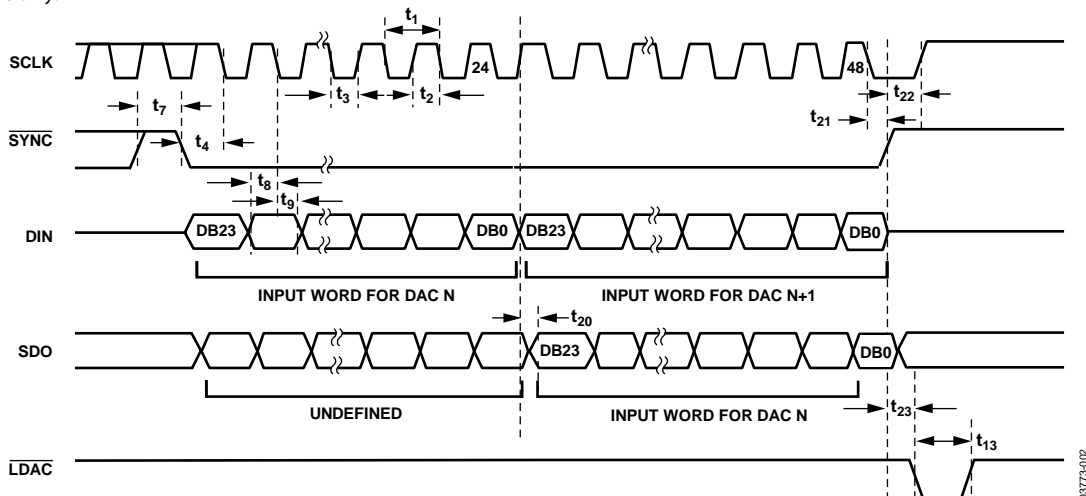

Figure 2. Serial Interface Timing Diagram (Daisy-Chain Mode)

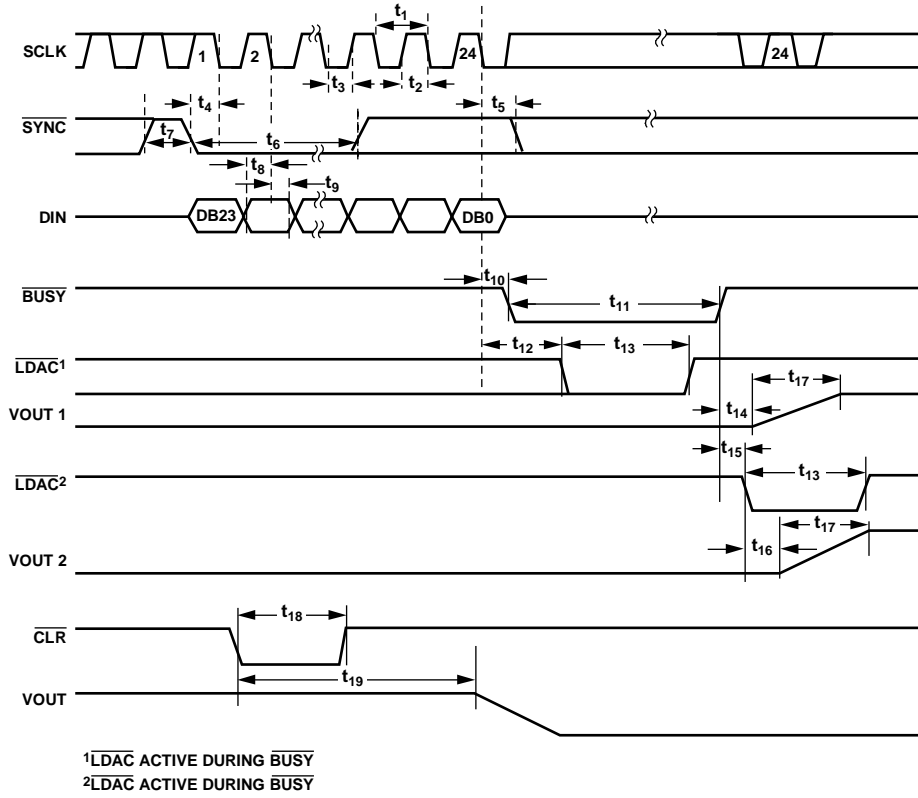

Figure 3. Serial Interface Timing Diagram (Standalone Mode)

03773-005

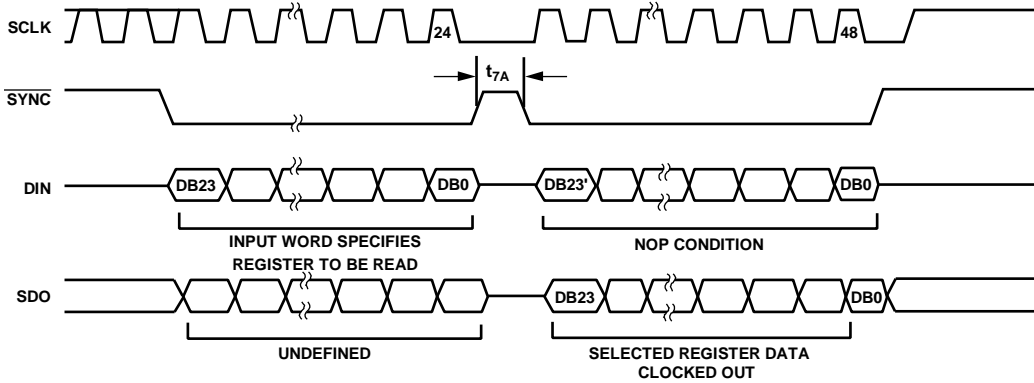

Figure 4. Serial Interface Timing Diagram (Data Readback Mode)

03773-008

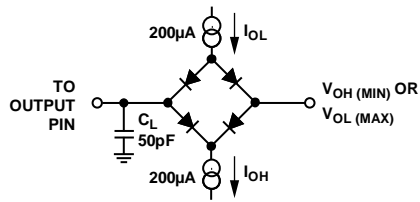

Figure 5. Load Circuit for Digital Output Timing

03773-003

I<sup>2</sup>C SERIAL INTERFACE

DV<sub>DD</sub> = 2.7 V to 5.5 V; AV<sub>DD</sub> = 2.7 V to 5.5 V; AGND = DGND = 0 V. All specifications T<sub>MIN</sub> to T<sub>MAX</sub>, unless otherwise noted.

Table 6. I<sup>2</sup>C Serial Interface<sup>1</sup>

Parameter <sup>2</sup>	Limit at T <sub>MIN</sub> , T <sub>MAX</sub>	Unit	Description
F <sub>SCL</sub>	400	kHz max	SCL clock frequency
t <sub>1</sub>	2.5	μs min	SCL cycle time
t <sub>2</sub>	0.6	μs min	t <sub>HIGH</sub> , SCL high time
t <sub>3</sub>	1.3	μs min	t <sub>LOW</sub> , SCL low time
t <sub>4</sub>	0.6	μs min	t <sub>HD, STA</sub> , start/repeated start condition hold time
t <sub>5</sub>	100	ns min	t <sub>SU, DAT</sub> , data setup time
t <sub>6</sub> <sup>3</sup>	0.9	μs max	t <sub>HD, DAT</sub> data hold time
	0	μs min	t <sub>HD, DAT</sub> data hold time
t <sub>7</sub>	0.6	μs min	t <sub>SU, STA</sub> setup time for repeated start
t <sub>8</sub>	0.6	μs min	t <sub>SU, STO</sub> stop condition setup time
t <sub>9</sub>	1.3	μs min	t <sub>BUF, F</sub> , bus free time between a stop and a start condition
t <sub>10</sub>	300	ns max	t <sub>F</sub> , fall time of SDA when transmitting
	0	ns min	t <sub>R</sub> , rise time of SCL and SDA when receiving (CMOS-compatible)
t <sub>11</sub>	300	ns max	t <sub>F</sub> , fall time of SDA when transmitting
	0	ns min	t <sub>F</sub> , fall time of SDA when receiving (CMOS-compatible)
	300	ns max	t <sub>F</sub> , fall time of SCL and SDA when receiving
	20 + 0.1 C <sub>B</sub>	ns min	t <sub>F</sub> , fall time of SCL and SDA when transmitting
C <sub>B</sub> <sup>4</sup>	400	pF max	Capacitive load for each bus line

<sup>1</sup> Guaranteed by design and characterization, not production tested.

<sup>2</sup> See Figure 6.

<sup>3</sup> A master device must provide a hold time of at least 300 ns for the SDA signal (referred to the V<sub>IH</sub> MIN of the SCL signal) to bridge the undefined region of SCL's falling edge.

<sup>4</sup> C<sub>B</sub> is the total capacitance of one bus line in pF; t<sub>r</sub> and t<sub>f</sub> measured between 0.3 DV<sub>DD</sub> and 0.7 DV<sub>DD</sub>.

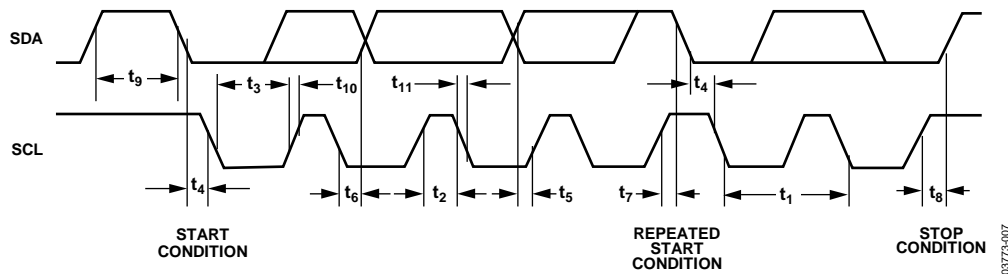

Figure 6. I<sup>2</sup>C Interface Timing Diagram

08773-087

## ABSOLUTE MAXIMUM RATINGS

Transient currents of up to 100 mA do not cause SCR latch-up.

$T_A = 25^\circ\text{C}$ , unless otherwise noted.

Table 7.

Parameter	Rating
$AV_{DD}$ to AGND	-0.3 V to +7 V
$DV_{DD}$ to DGND	-0.3 V to +7 V
Digital Inputs to DGND	-0.3 V to $DV_{DD} + 0.3$ V
Digital Outputs to DGND	-0.3 V to $DV_{DD} + 0.3$ V
VREF to AGND	-0.3 V to +7 V
REFOUT to AGND	-0.3 V to +7 V
AGND to DGND	-0.3 V to +0.3 V
VOUTX to AGND	-0.3 V to $AV_{DD} + 0.3$ V
ESD	
HBM	6.5 kV
FICSM	2 kV
Operating Temperature Range	
Commercial (B Version)	$-40^\circ\text{C}$ to $+85^\circ\text{C}$
Storage Temperature Range	$-65^\circ\text{C}$ to $+150^\circ\text{C}$
Junction Temperature ( $T_J$ max)	$150^\circ\text{C}$
64-Lead LFCSP, $\theta_{JA}$	$22^\circ\text{C}/\text{W}$
52-Lead LQFP, $\theta_{JA}$	$38^\circ\text{C}/\text{W}$
Reflow Soldering Peak Temperature	$230^\circ\text{C}$

Stresses above absolute maximum ratings may cause permanent damage to the device. This is a stress rating only; functional operation of the device at these or any other conditions above those listed in the operational sections of this specification is not implied. Exposure to absolute maximum rating conditions for extended periods may affect device reliability.

### ESD CAUTION



**ESD (electrostatic discharge) sensitive device.** Charged devices and circuit boards can discharge without detection. Although this product features patented or proprietary protection circuitry, damage may occur on devices subjected to high energy ESD. Therefore, proper ESD precautions should be taken to avoid performance degradation or loss of functionality.

# PIN CONFIGURATIONS AND FUNCTION DESCRIPTIONS

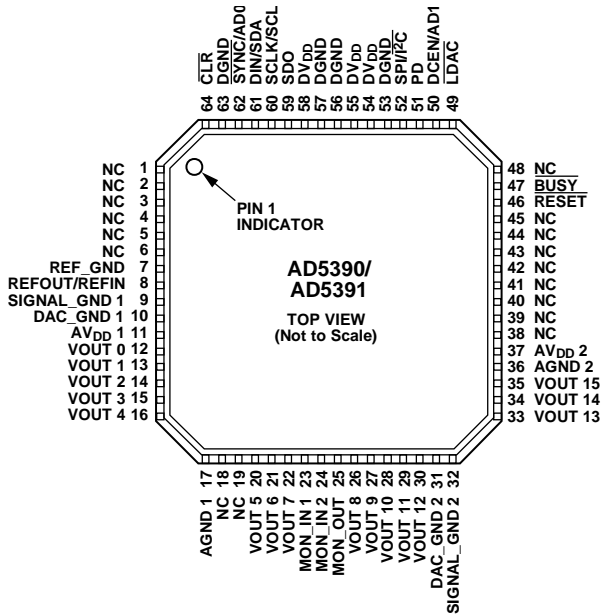

NOTES  
 1. NC = NO CONNECT.  
 2. THE EXPOSED PAD SHOULD BE CONNECTED TO THE GROUND PLANE.

Figure 7. AD5390/AD5391 LFCSP Pin Configuration

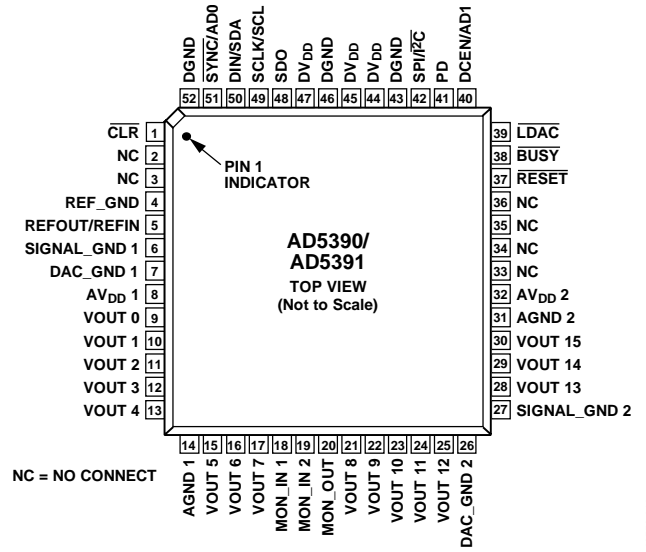
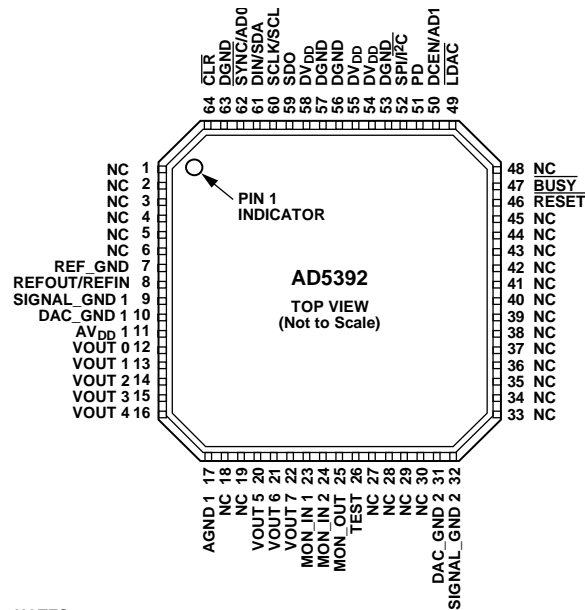

Figure 9. AD5390/AD5391 LQFP Pin Configuration



NOTES  
 1. NC = NO CONNECT.  
 2. THE EXPOSED PAD SHOULD BE CONNECTED TO THE GROUND PLANE.

Figure 8. AD5392 LFCSP Pin Configuration

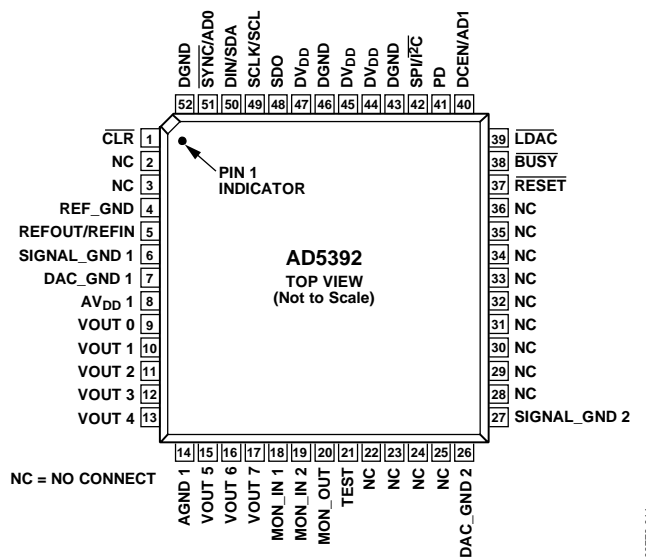

Figure 10. AD5392 LQFP Pin Configuration

03773-008

03773-009

03773-010

03773-011

Table 8. Pin Function Descriptions

Mnemonic	Function
VOUT X	Buffered Analog Outputs for Channel X. Each analog output is driven by a rail-to-rail output amplifier operating at a gain of 2. Each output is capable of driving an output load of 5 k $\Omega$ to ground. Typical output impedance is 0.5 $\Omega$ .
SIGNAL_GND 1, SIGNAL_GND 2	Analog Ground Reference Points for each group of eight output channels. All SIGNAL_GND pins are tied together internally and should be connected to the AGND plane as close as possible to the <a href="#">AD5390/AD5391/AD5392</a> .
DAC_GND 1, DAC_GND 2	Each group of eight channels contains a DAC_GND pin. This is the ground reference point for the internal 14-bit DACs. These pins should be connected to the AGND plane.
AGND 1, AGND 2	Analog Ground Reference Point. Each group of eight channels contains an AGND pin. All AGND pins should be connected externally to the AGND plane.
AV <sub>DD</sub> 1, AV <sub>DD</sub> 2	Analog Supply Pins. Each group of eight channels has a separate AV <sub>DD</sub> pin. These pins should be decoupled with 0.1 $\mu$ F ceramic capacitors and 10 $\mu$ F tantalum capacitors. Operating range is 5 V $\pm$ 10%.
DGND	Ground for All Digital Circuitry.
DV <sub>DD</sub>	Logic Power Supply. Guaranteed operating range is 2.7 V to 5.5 V. Recommended that these pins be decoupled with 0.1 $\mu$ F ceramic capacitors and 10 $\mu$ F tantalum capacitors to DGND.
REF_GND	Ground Reference Point for the Internal Reference. Connect to AGND.
REFOUT/REFIN	The <a href="#">AD5390/AD5391/AD5392</a> contains a common REFOUT/REFIN pin. When the internal reference is selected, this pin is the reference output. If the application necessitates the use of an external reference, it can be applied to this pin and the internal reference disabled via the control register. The default for this pin is a reference input.
MON_OUT	Analog Output Pin. When the monitor function is enabled on the <a href="#">AD5390/AD5391</a> , the MON_OUT acts as the output of a 16-to-1 channel multiplexer that can be programmed to multiplex any channel output to the MON_OUT pin. When the monitor function is enabled on the <a href="#">AD5392</a> , the MON_OUT acts as the output of an 8-to-1 channel multiplexer that can be programmed to multiplex any channel output to the MON_OUT pin. The MON_OUT pin output impedance is typically 500 $\Omega$ and is intended to drive a high input impedance such as that exhibited by SAR ADC inputs.
MON_IN 1, MON_IN 2	Monitor Input Pins. The <a href="#">AD5390/AD5391/AD5392</a> contains two monitor input pins to which the user can connect input signals (within the maximum ratings of the device) for monitoring purposes. Any of the signals applied to the MON_IN pins along with the output channels can be switched to the MON_OUT pin via software. An external ADC, for example, can be used to monitor these signals.
$\overline{\text{SYNC}}$ /AD0	Serial Interface Pin. This is the frame synchronization input signal for the serial interface. When taken low, the internal counter is enabled to count the required number of clocks before the addressed register is updated. In I <sup>2</sup> C mode, AD0 acts as a hardware address pin.
DCEN/AD1	Interface Control Pin. Operation is determined by the interface select bit SPI/I <sup>2</sup> C. Serial Interface Mode: Daisy-Chain Select Input (level-sensitive, active high). When high, this pin enables daisy-chain operation to allow a number of devices to be cascaded together. I <sup>2</sup> C Mode: This pin acts as a hardware address pin used in conjunction with AD0 to determine the software address for this device on the I <sup>2</sup> C bus.
SDO	Serial Data Output. Three-state CMOS output. SDO can be used for daisy-chaining a number of devices together. Data is clocked out on SDO on the rising edge of SCLK and is valid on the falling edge of SCLK.
$\overline{\text{BUSY}}$	Digital CMOS Output. $\overline{\text{BUSY}}$ goes low during internal calculations of the data (x2) loaded to the DAC data register. During this time, the user can continue writing new data to further the x1, c, and m registers (these are stored in a FIFO), but no further updates to the DAC registers and DAC outputs can take place. If $\overline{\text{LDAC}}$ is taken low while $\overline{\text{BUSY}}$ is low, this event is stored. $\overline{\text{BUSY}}$ also goes low during power-on reset and when the $\overline{\text{RESET}}$ pin is low. During this time the interface is disabled and any events on $\overline{\text{LDAC}}$ are ignored. A CLR operation also brings $\overline{\text{BUSY}}$ low.
$\overline{\text{LDAC}}$	Load DAC Logic Input (active low). If $\overline{\text{LDAC}}$ is taken low while $\overline{\text{BUSY}}$ is inactive (high), the contents of the input registers are transferred to the DAC registers and the DAC outputs are updated. If $\overline{\text{LDAC}}$ is taken low while $\overline{\text{BUSY}}$ is active and internal calculations are taking place, the $\overline{\text{LDAC}}$ event is stored and the DAC registers are updated when $\overline{\text{BUSY}}$ goes inactive. However, any events on $\overline{\text{LDAC}}$ during power-on reset or $\overline{\text{RESET}}$ are ignored.
$\overline{\text{CLR}}$	Asynchronous Clear Input. The $\overline{\text{CLR}}$ input is falling edge sensitive. While $\overline{\text{CLR}}$ is low, all $\overline{\text{LDAC}}$ pulses are ignored. When $\overline{\text{CLR}}$ is activated, all channels are updated with the data contained in the $\overline{\text{CLR}}$ code register. $\overline{\text{BUSY}}$ is low for a duration of 20 $\mu$ s ( <a href="#">AD5390/AD5391</a> ) and 15 $\mu$ s ( <a href="#">AD5392</a> ) while all channels are being updated with the $\overline{\text{CLR}}$ code.
$\overline{\text{RESET}}$	Asynchronous Digital Reset Input (falling edge sensitive). The function of this pin is equivalent to that of the power-on reset generator. When this pin is taken low, the state machine initiates a reset sequence to digitally reset the x1, m, c, and x2 registers to their default power-on values. This sequence takes 270 $\mu$ s maximum. This falling edge of $\overline{\text{RESET}}$ initiates the RESET process and $\overline{\text{BUSY}}$ goes low for the duration, returning high when $\overline{\text{RESET}}$ is complete. While $\overline{\text{BUSY}}$ is low, all interfaces are disabled and all $\overline{\text{LDAC}}$ pulses are ignored. When $\overline{\text{BUSY}}$ returns high, the part resumes normal operation and the status of the $\overline{\text{RESET}}$ pin is ignored until the next falling edge is detected.

Mnemonic	Function
PD	Power-Down (level-sensitive, active high). Used to place the device in low power mode, in which the device consumes 1 $\mu$ A analog current and 20 $\mu$ A digital current. In power-down mode, all internal analog circuitry is placed in low power mode; the analog output is configured as high impedance outputs or provides a 100 k $\Omega$ load to ground, depending on how the power-down mode is configured. The serial interface remains active during power-down.
SPI/ $\overline{\text{I}^2\text{C}}$	Interface Select Input Pin. When this input is low, I <sup>2</sup> C mode is selected. When this input is high, SPI mode is selected.
SCLK/SCL	Interface Clock Input Pin. In SPI-compatible serial interface mode, this pin acts as a serial clock input. It operates at clock speeds up to 50 MHz. I <sup>2</sup> C mode: In I <sup>2</sup> C mode, this pin performs the SCL function, clocking data into the device. Data transfer rate in I <sup>2</sup> C mode is compatible with both 100 kHz and 400 kHz operating modes.
DIN/SDA	Interface Data Input Pin. SPI/ $\overline{\text{I}^2\text{C}}$ = 1: This pin acts as the serial data input. Data must be valid on the falling edge of SCLK. SPI/ $\overline{\text{I}^2\text{C}}$ = 0, I <sup>2</sup> C mode: In I <sup>2</sup> C mode, this pin is the serial data pin (SDA) operating as an open drain input/output.
TEST	Test pin (AD5392 only). This pin is used for production testing. For normal operation, this pin should not be connected.
NC	No Connect. These pins have no internal connection.
Exposed Pad (LFCSF only)	This pad should be connected to the ground plane.

## TERMINOLOGY

### Relative Accuracy or Endpoint Linearity (INL)

A measure of the maximum deviation from a straight line passing through the endpoints of the DAC transfer function. It is measured after adjusting for zero-scale error and full-scale error and is expressed in least significant bits (LSBs).

### Differential Nonlinearity (DNL)

The difference between the measured change and the ideal 1 LSB change between any two adjacent codes. A specified differential nonlinearity of 1 LSB maximum ensures monotonicity.

### Zero-Scale Error

The error in the DAC output voltage when all 0s are loaded into the DAC register. Ideally, with all 0s loaded to the DAC and  $m = \text{all } 1\text{s}$ ,  $c = 2^{n-1}$ ,  $V_{\text{OUT}}(\text{Zero-Scale}) = 0 \text{ V}$ .

Zero-scale error is a measure of the difference between  $V_{\text{OUT}}$  (actual) and  $V_{\text{OUT}}$  (ideal) expressed in mV. It is mainly caused by offsets in the output amplifier.

### Offset Error

A measure of the difference between  $V_{\text{OUT}}$  (actual) and  $V_{\text{OUT}}$  (ideal) expressed in mV in the linear region of the transfer function. Offset error is measured on the [AD5390-5/AD5391-5/AD5392-5](#) with code 32 loaded in the DAC register and with code 64 loaded in the DAC register on the [AD5390-3/AD5391-3/AD5392-3](#).

### Gain Error

The deviation in slope of the DAC transfer characteristic from ideal and is expressed in % FSR with the DAC output unloaded. Gain error is specified in the linear region of the output range between  $V_{\text{OUT}} = 10 \text{ mV}$  and  $V_{\text{OUT}} = AV_{\text{DD}} - 50 \text{ mV}$ .

### DC Crosstalk

The dc change in the output level of one DAC at midscale in response to a full-scale code (all 0s to all 1s and vice versa) and the output change of all other DACs. It is expressed in LSBs.

### DC Output Impedance

The effective output source resistance. It is dominated by package lead resistance.

### Output Voltage Settling Time

The amount of time it takes for the output of a DAC to settle to a specified level for a  $\frac{1}{4}$  to  $\frac{3}{4}$  full-scale input change. It is measured from the rising edge of  $\overline{\text{BUSY}}$ .

### Digital-to-Analog Glitch Energy

The amount of energy injected into the analog output at the major code transition. It is specified as the area of the glitch in nV-s. It is measured by toggling the DAC register data between 0x1FFF and 0x2000.

### DAC-to-DAC Crosstalk

The glitch impulse that appears at the output of one DAC due to both the digital change and subsequent analog output change at another DAC. The victim channel is loaded with midscale, and DAC-to-DAC crosstalk is specified in nV-s.

### Digital Crosstalk

The glitch impulse transferred to the output of one converter due to a change in the DAC register code of another converter is defined as the digital crosstalk and is specified in nV-s.

### Digital Feedthrough

When the device is not selected, high frequency logic activity on the device's digital inputs can be capacitively coupled both across and through the device to show up as noise on the  $V_{\text{OUT}}$  pins. It can also be coupled along the supply and ground lines. This noise is digital feedthrough.

### Output Noise Spectral Density

This is a measure of internally generated random noise. Random noise is characterized as a spectral density (voltage per  $\sqrt{\text{Hz}}$ ). It is measured by loading all DACs to midscale and measuring noise at the output. It is measured in  $\text{nV}/(\text{Hz})^{1/2}$  in a 1 Hz bandwidth at 10 kHz.

TYPICAL PERFORMANCE CHARACTERISTICS

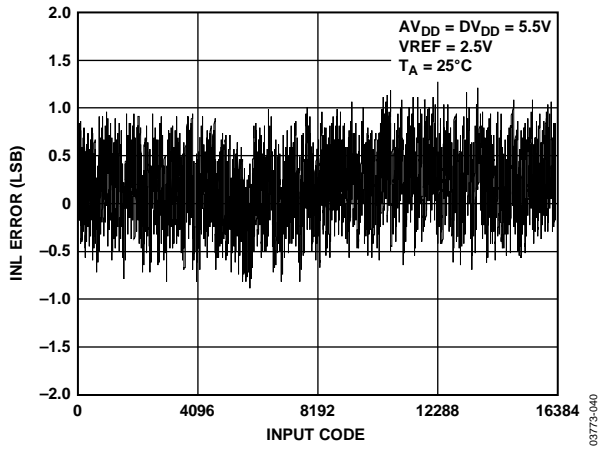

Figure 11. AD5390-5/AD5392-5 Typical INL Plot

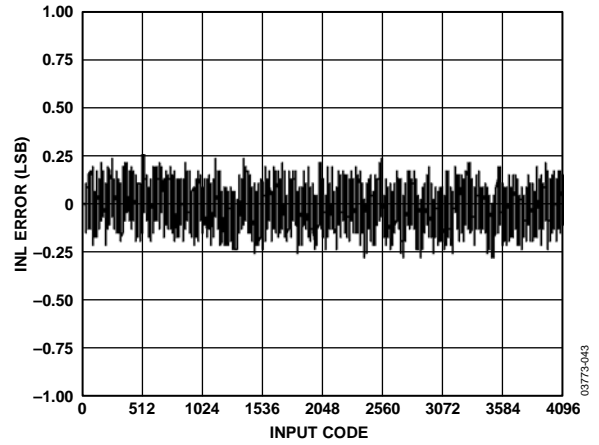

Figure 14. Typical AD5391-5 INL Plot

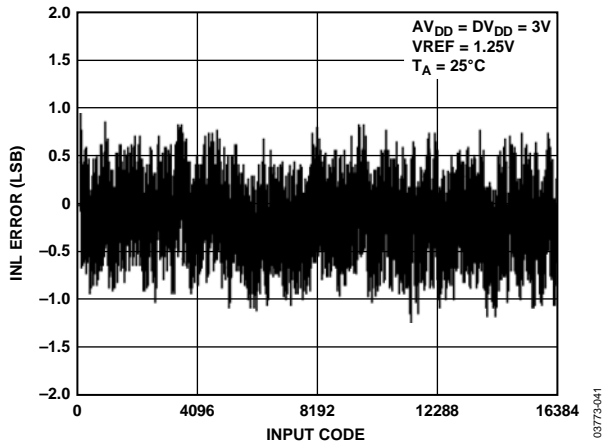

Figure 12. AD5390-3/AD5392-3 INL Plot

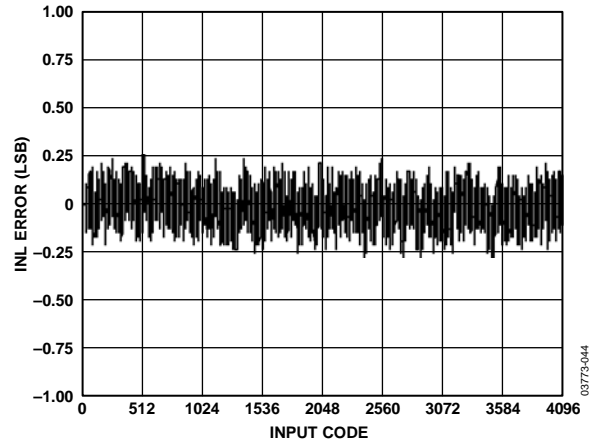

Figure 15. Typical AD5391-3 INL Plot

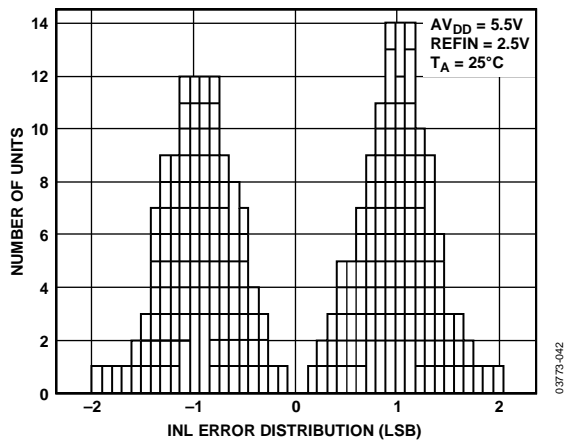

Figure 13. AD5390/AD5392 INL Histogram Plot

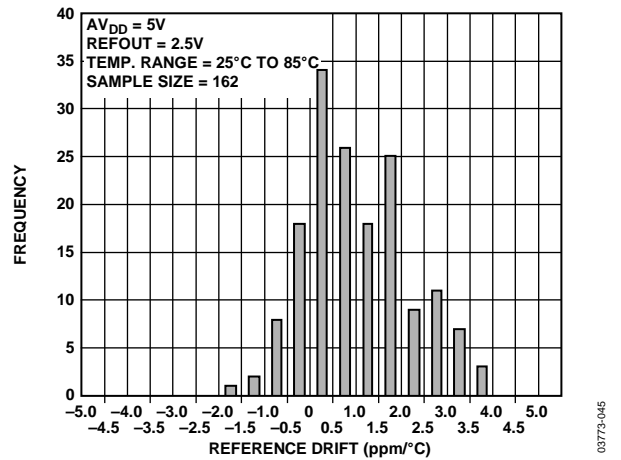

Figure 16. AD5390/AD5391/AD5392 REFOUT Temperature Coefficient

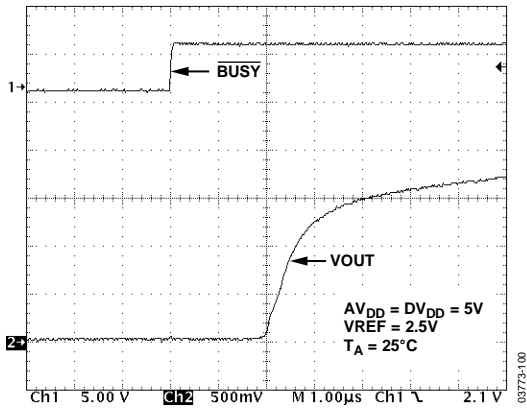

Figure 17. AD5390/AD5391/AD5392 Exiting Soft Power-Down

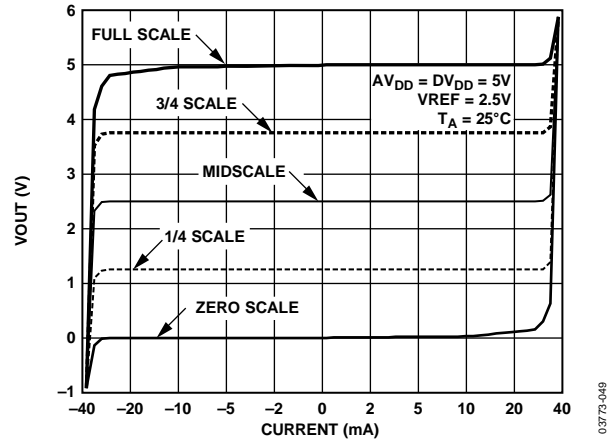

Figure 20. AD5390-5/AD5391-5/AD5392-5 Source and Sink Capability

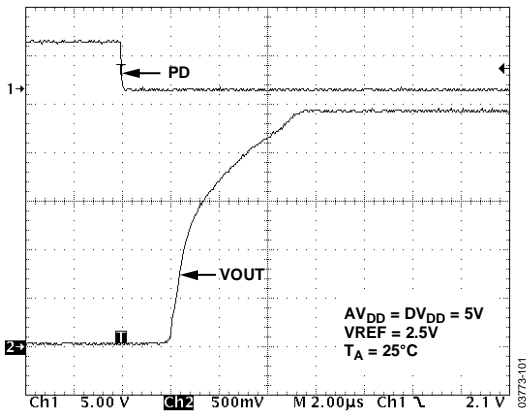

Figure 18. AD5390/AD5391/AD5392 Exiting Hardware Power-Down

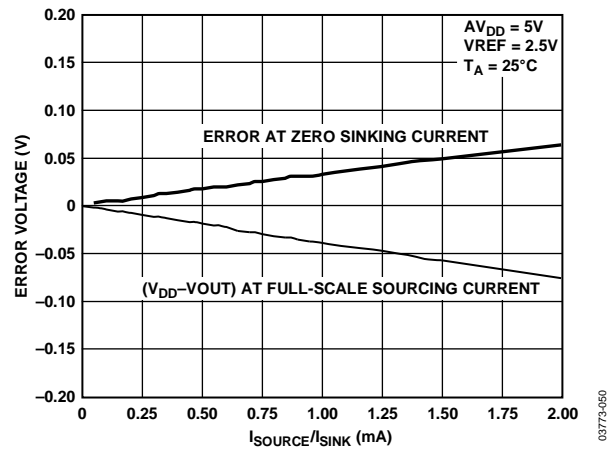

Figure 21. Headroom at Rails vs. Source/Sink Current

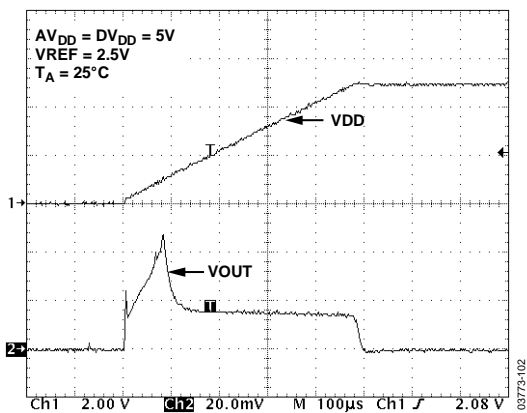

Figure 19. AD5390/AD5391/AD5392 Power-Up Transient

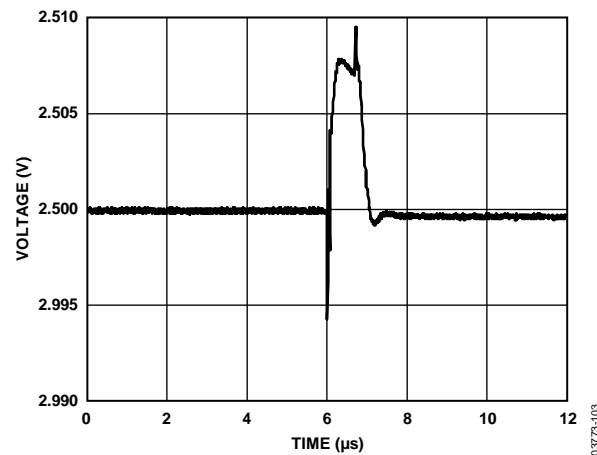

Figure 22. AD5390-5/AD5391-5/AD5392-5 Glitch Impulse Energy

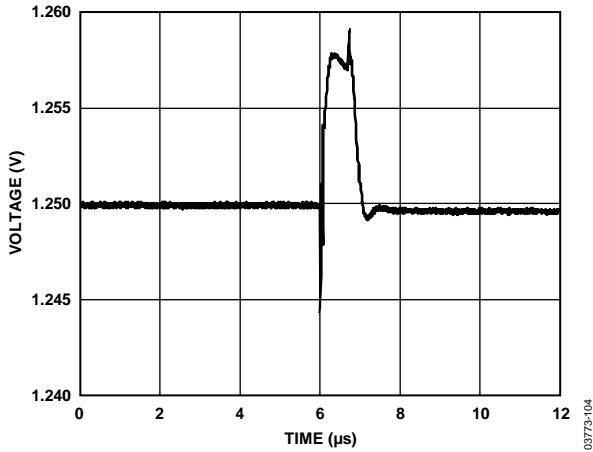

Figure 23. AD5390-3/AD5391-3/AD5392-3 Glitch Impulse

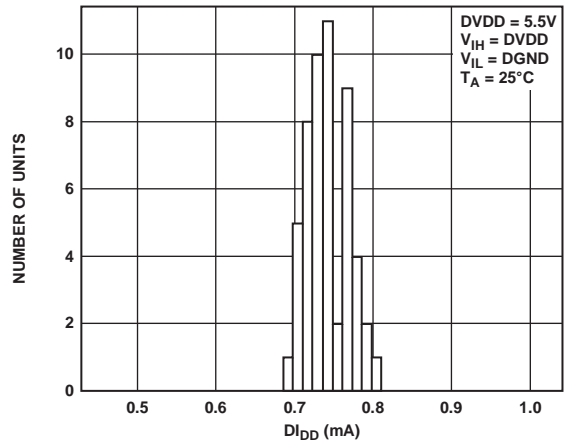

Figure 26. AD5390/AD5391/AD5392  $DI_{DD}$  Histogram

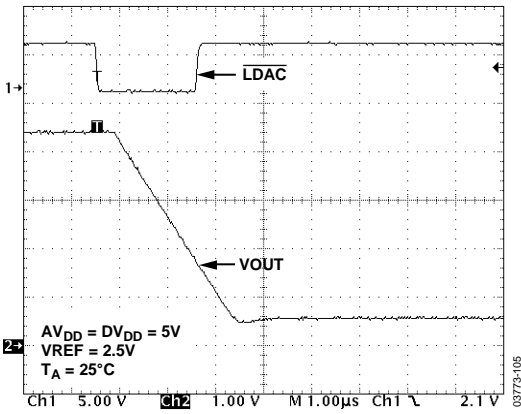

Figure 24. AD5390/AD5391/AD5392 Slew Rate Boost Off

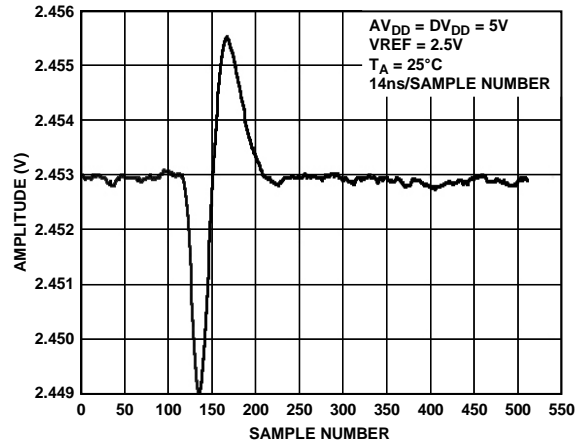

Figure 27. AD5390/AD5391/AD5392 Adjacent Channel Crosstalk

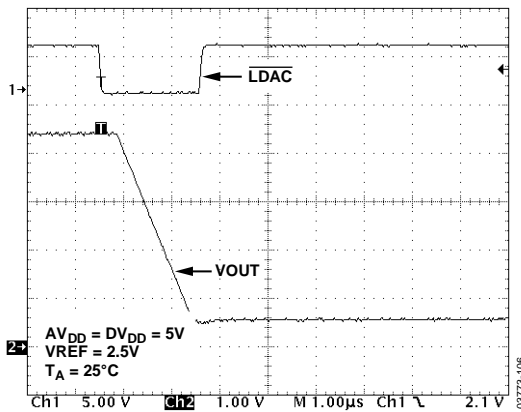

Figure 25. AD5390/AD5391/AD5392 Slew Rate Boost On

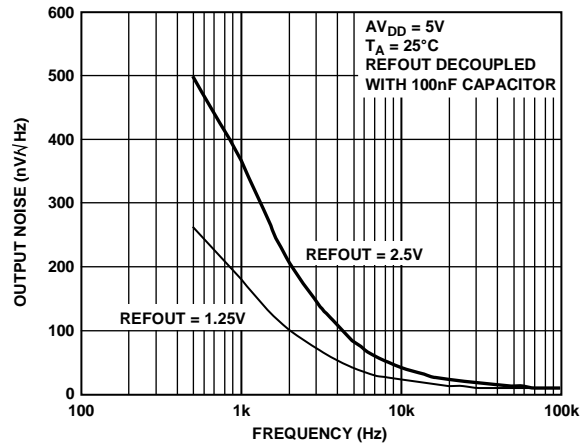

Figure 28. AD5390/AD5391/AD5392 REFOUT Noise Spectral Density

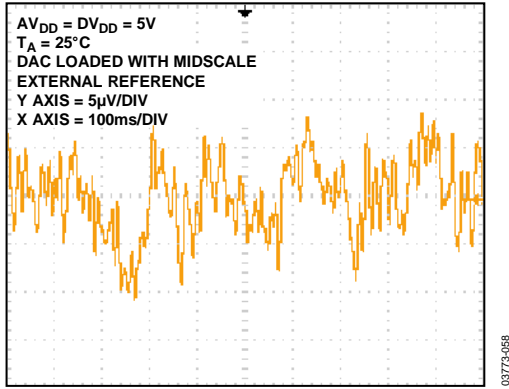

Figure 29. 0.1 Hz to 10 Hz Output Noise Plot

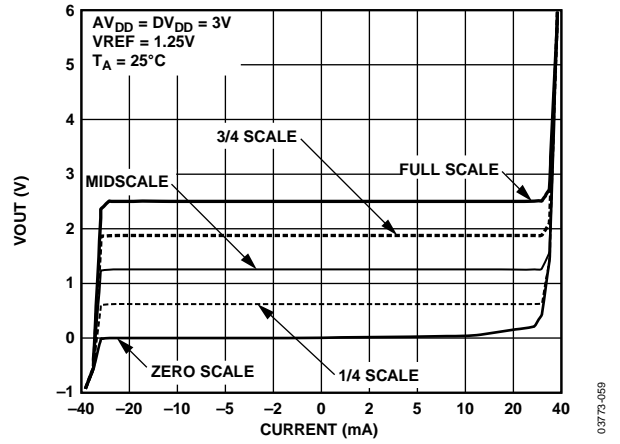

Figure 30. AD5390-3/AD5391-3/AD5392-3 Source and Sink Current Capability

## FUNCTIONAL DESCRIPTION

### DAC ARCHITECTURE

The [AD5390/AD5391](#) are complete single-supply, 16-channel, voltage output DACs offering a resolution of 14 bits and 12 bits, respectively. The [AD5392](#) is a complete single-supply, 8-channel, voltage output DAC offering 14-bit resolution. All devices are available in a 64-lead LFCSP and 52-lead LQFP, and feature serial interfaces. This family includes an internal select-able 1.25 V/2.5 V, 10 ppm/°C reference that can be used to drive the buffered reference inputs (alternatively, an external reference can be used to drive these inputs). All channels have an on-chip output amplifier with rail-to-rail output capable of driving a 5 kΩ load in parallel with a 200 pF capacitance.

The architecture of a single DAC channel consists of a 12-bit and 14-bit resistor-string DAC followed by an output buffer amplifier operating at a gain of 2. This resistor-string architecture guarantees DAC monotonicity. The 12-bit and 14-bit binary digital code loaded to the DAC register determines at what node on the string the voltage is tapped off before being fed to the output amplifier. Each channel on these devices contains independent offset and gain control registers, allowing the user to digitally trim offset and gain.

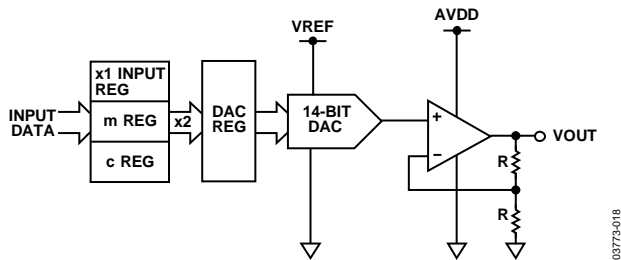

Figure 31. Single-Channel Architecture

These registers let the user calibrate out errors in the complete signal chain including the DAC using the internal *m* and *c* registers, which hold the correction factors. All channels are double-buffered, allowing synchronous updating of all channels using the  $\overline{\text{LDAC}}$  pin. Figure 31 shows a block diagram of a single channel on the [AD5390/AD5391/AD5392](#).

The digital input transfer function for each DAC can be represented as

$$x_2 = \left( \frac{m+2}{2^n} \right) \times x_1 + \left( c - 2^{n-1} \right)$$

where:

*x*<sub>2</sub> is the data-word loaded to the resistor-string DAC.

*x*<sub>1</sub> is the 12-bit and 14-bit data-word written to the DAC input register.

*m* is the 12-bit and 14-bit gain coefficient (default is all 0x3FFE on the [AD5390/AD5392](#) and 0xFFE on the [AD5391](#)). The LSB of the gain coefficient is zero.

*n* = DAC resolution (*n* = 14 for the [AD5390/AD5392](#) and *n* = 12 for the [AD5391](#)).

*c* is the 12-bit and 14-bit offset coefficient (default is 0x2000 on the [AD5390/AD5392](#) and 0x800 on the [AD5391](#)).

The complete transfer function for these devices can be represented as

$$V_{OUT} = 2 \times V_{REF} \times x_2 / 2^n$$

where:

*x*<sub>2</sub> is the data-word loaded to the resistor-string DAC.

*V*<sub>REF</sub> is the reference voltage applied to the REFIN/REFOUT pin on the DAC when an external reference is used (2.5 V for specified performance on the [AD5390-5/AD5391-5/AD5392-5](#) and 1.25 V on the [AD5390-3/AD5391-3/AD5392-3](#)).

**DATA DECODING**

**AD5390/AD5392**

The AD5390/AD5392 contain an internal 14-bit data bus. The input data is decoded depending on the data loaded to the REG1 and REG0 bits of the input serial register. This is shown in Table 9.

Data from the serial input register is loaded into the addressed DAC input register, offset (c) register, or gain (m) register. The format data, and the offset (c) and gain (m) register contents are shown in Table 10 to Table 12.

**Table 9. Register Selection**

REG1	REG0	Register Selected
1	1	Input data register (x1)
1	0	Offset register (c)
0	1	Gain register (m)
0	0	Special function registers (SFRs)

**Table 10. AD5390/AD5392 DAC Data Format (REG1 = 1, REG0 = 1)**

DB13 to DB0	DAC Output (V)		
11 1111 1111 1111	2 V <sub>REF</sub> × (16383/16384)		
11 1111 1111 1110	2 V <sub>REF</sub> × (16382/16384)		
10 0000 0000 0001	2 V <sub>REF</sub> × (8193/16384)		
10 0000 0000 0000	2 V <sub>REF</sub> × (8192/16384)		
01 1111 1111 1111	2 V <sub>REF</sub> × (8191/16384)		
00 0000 0000 0001	2 V <sub>REF</sub> × (1/16384)		
00 0000 0000 0000	0		

**Table 11. AD5390/AD5392 Offset Data Format (REG1 = 1, REG0 = 0)**

DB13 to DB0	Offset (LSB)		
111111 1111 1111 1111	+8191		
111111 1111 1110 1110	+8190		
100000 0000 0001 0001	+1		
100000 0000 0000 0000	+0		
011111 1111 1111 1111	-1		
000000 0000 0001 0001	-8191		
000000 0000 0000 0000	-8192		

**Table 12. AD5390/AD5392 Gain Data Format (REG1 = 0, REG0 = 1)**

DB13 to DB0	Gain Factor		
11 1111 1111 1110	1		
10 1111 1111 1110	0.75		
01 1111 1111 1110	0.5		
00 1111 1111 1110	0.25		
00 0000 0000 0000	0		

**AD5391**

The AD5391 contains an internal 12-bit data bus. The input data is decoded depending on the value loaded to the REG1 and REG0 bits of the input serial register. The input data from the serial input register is loaded into the addressed DAC input register, offset (c) register, or gain (m) register. The format data and the offset (c) and gain (m) register contents are shown in Table 13 to Table 15.

**Table 13. AD5391 DAC Data Format (REG1 = 1, REG0 = 1)**

DB11 to DB0	DAC Output (V)		
1111 1111 1111 1111	2 V <sub>REF</sub> × (4095/4096)		
1111 1111 1110 1110	2 V <sub>REF</sub> × (4094/4096)		
1000 0000 0001 0001	2 V <sub>REF</sub> × (2049/4096)		
1000 0000 0000 0000	2 V <sub>REF</sub> × (2048/4096)		
0111 1111 1111 1111	2 V <sub>REF</sub> × (2047/4096)		
0000 0000 0001 0001	2 V <sub>REF</sub> × (1/4096)		
0000 0000 0000 0000	0		

**Table 14. AD5391 Offset Data Format (REG1 = 1, REG0 = 0)**

DB11 to DB0	Offset (LSB)		
1111 1111 1111 1111	+2047		
1111 1111 1110 1110	+2046		
1000 0000 0001 0001	+1		
1000 0000 0000 0000	+0		
0111 1111 1111 1111	-1		
0000 0000 0001 0001	-2047		
0000 0000 0000 0000	-2048		

**Table 15. AD5391 Gain Data Format (REG1 = 0, REG0 = 1)**

DB11 to DB0	Gain Factor		
1111 1111 1110 1110	1		
1011 1111 1110 1110	0.75		
0111 1111 1110 1110	0.5		
0011 1111 1110 1110	0.25		
0000 0000 0000 0000	0		

## INTERFACES

The [AD5390/AD5391/AD5392](#) contain a serial interface that can be programmed to be DSP-, SPI-, and MICROWIRE-compatible, or I<sup>2</sup>C-compatible. The SPI/I<sup>2</sup>C pin is used to select the interface mode.

To minimize both the power consumption of the device and the on-chip digital noise, the interface fully powers up only when the device is being written to, that is, on the falling edge of  $\overline{\text{SYNC}}$ .

### DSP-, SPI-, AND MICROWIRE-COMPATIBLE SERIAL INTERFACE

The serial interface can be operated with a minimum of three wires in standalone mode or four wires in daisy-chain mode. Daisy-chaining allows many devices to be cascaded together to increase system channel count. The SPI/I<sup>2</sup>C pin is tied to a

Logic 1 pin to configure this mode of operation. The serial interface control pins are described in Table 16.

**Table 16. Serial Interface Control Pins**

Pin	Description
$\overline{\text{SYNC}}$ , DIN, SCLK	Standard 3-wire interface pins.
DCEN	Selects standalone mode or daisy-chain mode.
SDO	Data out pin for daisy-chain mode.

Figure 2 to Figure 4 show timing diagrams for a serial write to the [AD5390/AD5391/AD5392](#) in both standalone and daisy-chain mode. The 24-bit data-word format for the serial interface is shown in Table 17 to Table 19. Descriptions of the bits follow in Table 20.

**Table 17. AD5390 16-Channel, 14-Bit DAC Serial Input Register Configuration**

MSB																							LSB	
$\overline{\text{A/B}}$	$\text{R}/\overline{\text{W}}$	0	0	A3	A2	A1	A0	REG1	REG0	DB13	DB12	DB11	DB10	DB9	DB8	DB7	DB6	DB5	DB4	DB3	DB2	DB1	DB0	

**Table 18. AD5391 16-Channel, 12-Bit DAC Serial Input Register Configuration**

MSB																						LSB	
$\overline{\text{A/B}}$	$\text{R}/\overline{\text{W}}$	0	0	A3	A2	A1	A0	REG1	REG0	DB11	DB10	DB9	DB8	DB7	DB6	DB5	DB4	DB3	DB2	DB1	DB0	X	X

**Table 19. AD5392 8-Channel, 14-Bit DAC Serial Input Register Configuration**

MSB																							LSB	
$\overline{\text{A/B}}$	$\text{R}/\overline{\text{W}}$	0	0	0	A2	A1	A0	REG1	REG0	DB13	DB12	DB11	DB10	DB9	DB8	DB7	DB6	DB5	DB4	DB3	DB2	DB1	DB0	

**Table 20. Serial Input Register Configuration Bit Descriptions**

Bit	Description
$\overline{\text{A/B}}$	When toggle mode is enabled, this bit selects whether the data write is to the A or B register. With toggle mode disabled, this bit should be set to zero to select the A data register.
$\text{R}/\overline{\text{W}}$	The read or write control bit.
A3 to A0	Used to address the input channels.
REG1 and REG0	Select the register to which data is written, as outlined in Table 9.
DB13 to DB0	Contain the input data-word.
X	Don't care condition.

**Standalone Mode**

By connecting the daisy-chain enable (DCEN) pin low, stand-alone mode is enabled. The serial interface works with both a continuous and a noncontinuous serial clock. The first falling edge of SYNC starts the write cycle and resets a counter that counts the number of serial clocks to ensure that the correct number of bits is shifted into the serial shift register. Any further edges on SYNC (except for a falling edge) are ignored until 24 bits are clocked in. Once 24 bits have been shifted in, the SCLK is ignored. For another serial transfer to take place, the counter must be reset by the falling edge of SYNC.

**Daisy-Chain Mode**

For systems that contain several devices, the SDO pin can be used to daisy-chain the devices together. This daisy-chain mode can be useful in system diagnostics and for reducing the number of serial interface lines.

By connecting the DCEN pin high, daisy-chain mode is enabled. The first falling edge of SYNC starts the write cycle. The SCLK is continuously applied to the input shift register when SYNC is low. If more than 24 clock pulses are applied, the data ripples out of the shift register and appears on the SDO line. This data is clocked out on the rising edge of SCLK and is valid on the falling edge. By connecting the SDO of the first device to the DIN input on the next device in the chain, a multidevice interface is constructed. For each device in the system, 24 clock pulses are required. Therefore, the total number of clock cycles must equal 24N where N is the total number of AD5390/AD5391/AD5392 devices in the chain.

When the serial transfer to all devices is complete, SYNC is taken high. This latches the input data in each device in the daisy chain and prevents any further data from being clocked into the input shift register.

If SYNC is taken high before 24 clocks are clocked into the part, it is considered a bad frame and the data is discarded.

The serial clock can be either a continuous or a gated clock. A continuous SCLK source can be used only if the SYNC can be held low for the correct number of clock cycles. In gated clock mode, a burst clock containing the exact number of clock cycles must be used and SYNC taken high after the final clock to latch the data.

**Readback Mode**

Readback mode is invoked by setting the R/W bit = 1 in the serial input register write sequence. With R/W = 1, Bit A3 to Bit A0 in association with Bits REG1 and REG0 select the register to be read. The remaining data bits in the write sequence are don't care bits. During the next SPI write, the data appearing on the SDO output contains the data from the previously addressed register. For a read of a single register, the NOP command can be used in clocking out the data from the selected register on SDO.

The readback diagram in Figure 32 shows the readback sequence. For example, to read back the m register of Channel 0 on the AD5390/AD5391/AD5392, the following sequence should be implemented:

First, write 0x404XXX to the AD5390/AD5391/AD5392 input register. This configures the AD5390/AD5391/AD5392 for read mode with the m register of Channel 0 selected. Note that all data bits, DB13 to DB0, are don't care bits.

Follow this with a second write, a NOP condition, and 0x000000. During this write, the data from the m register is clocked out on the DOUT line, that is, data clocked out contains the data from the m register in Bit DB13 to Bit DB0, and the top 10 bits contain the address information as previously written. In readback mode, the SYNC signal must frame the data. Data is clocked out on the rising edge of SCLK and is valid on the falling edge of the SCLK signal. If the SCLK idles high between the write and read operations of a readback, the first bit of data is clocked out on the falling edge of SYNC.

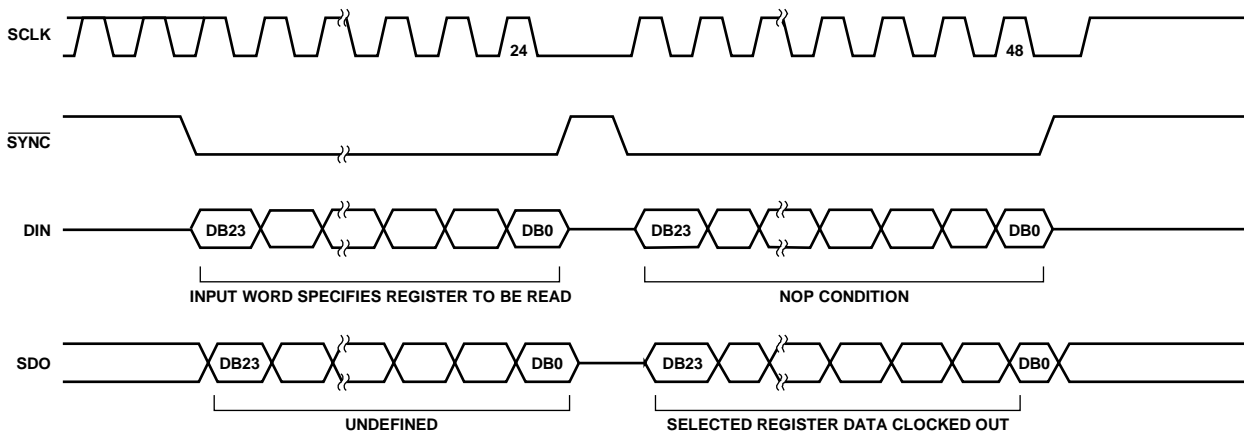

Figure 32. Readback Operation

03773-022

## I<sup>2</sup>C SERIAL INTERFACE

The [AD5390/AD5391/AD5392](#) feature an I<sup>2</sup>C-compatible 2-wire interface consisting of a serial data line (SDA) and a serial clock line (SCL). SDA and SCL facilitate communication between the DACs and the master at rates up to 400 kHz.

Figure 6 shows the 2-wire interface timing diagram.

When selecting the I<sup>2</sup>C operating mode by configuring the SPI/I<sup>2</sup>C pin to Logic 0, the device is connected to the I<sup>2</sup>C bus as a slave device, that is, no clock is generated by the device. The [AD5390/AD5391/AD5392](#) have a 7-bit slave address 1010 1 (AD1)(AD0). The five MSBs are hard-coded and the two LSBs are determined by the state of the AD1 and AD0 pins. The hardware configuration facility for the AD1 and AD0 pins allows four of these devices to be configured on the bus.

### I<sup>2</sup>C Data Transfer

One data bit is transferred during each SCL clock cycle. The data on SDA must remain stable during the high period of the SCL clock pulse. Changes in SDA while SCL is high are control signals that configure START and STOP conditions. Both SDA and SCL are pulled high by the external pull-up resistors when the I<sup>2</sup>C bus is not busy.

### START and STOP Conditions

A master device initiates communication by issuing a START condition. A START condition is a high-to-low transition on SDA with SCL high. A STOP condition is a low-to-high transition on SDA, while SCL is high. A START condition from the master signals the beginning of a transmission to the [AD5390/AD5391/AD5392](#). The STOP condition frees the bus. If a repeated START condition (Sr) is generated instead of a STOP condition, the bus remains active.

### Repeated START Condition

A repeated START (Sr) condition may indicate a change of data direction on the bus. Sr may be used when the bus master is writing to several I<sup>2</sup>C devices and does not want to relinquish control of the bus.

### Acknowledge Bit (ACK)

The acknowledge bit (ACK) is the ninth bit attached to any 8-bit data-word. An ACK is always generated by the receiving device. The [AD5390/AD5391/AD5392](#) devices generate an ACK when receiving an address or data by pulling SDA low during the ninth clock period.

Monitoring the ACK allows for detection of unsuccessful data transfers. An unsuccessful data transfer occurs if a receiving device is busy or if a system fault has occurred. In the event of an unsuccessful data transfer, the bus master should reattempt communication.

### AD5390/AD5391/AD5392 Slave Addresses

A bus master initiates communication with a slave device by issuing a START condition followed by the 7-bit slave address. When idle, the [AD5390/AD5391/AD5392](#) device waits for a START condition followed by its slave address. The LSB of the address word is the read/write (R/W) bit. The [AD5390/AD5391/AD5392](#) devices are receive devices only and  $R/\overline{W} = 0$  when communicating with them. After receiving the proper address 1010 1 (AD1) (AD0), the [AD5390/AD5391/AD5392](#) issues an ACK by pulling SDA low for one clock cycle. The [AD5390/AD5391/AD5392](#) has four user-programmable addresses determined by the AD1 and AD0 bits.

## I<sup>2</sup>C WRITE OPERATION

There are three specific modes in which data can be written to the [AD5390/AD5391/AD5392](#) DACs.

### 4-BYTE MODE

When writing to the [AD5390/AD5391/AD5392](#) DACs, begin with an address byte ( $R/\bar{W} = 0$ ), after which the DAC acknowledges that it is prepared to receive data by pulling SDA low. The address byte is followed by the pointer byte. This addresses the specific channel in the DAC to be addressed and

is also acknowledged by the DAC. Address Bits A3 to A0 address all channels on the [AD5390/AD5391](#). Address Bits A2 to A0 address all channels on the [AD5392](#). Address Bit A3 is a zero on the [AD5392](#). Two bytes of data are then written to the DAC, as shown in Figure 33. A STOP condition follows. This lets the user update a single channel within the [AD5390/AD5391/AD5392](#) at any time and requires four bytes of data to be transferred from the master.

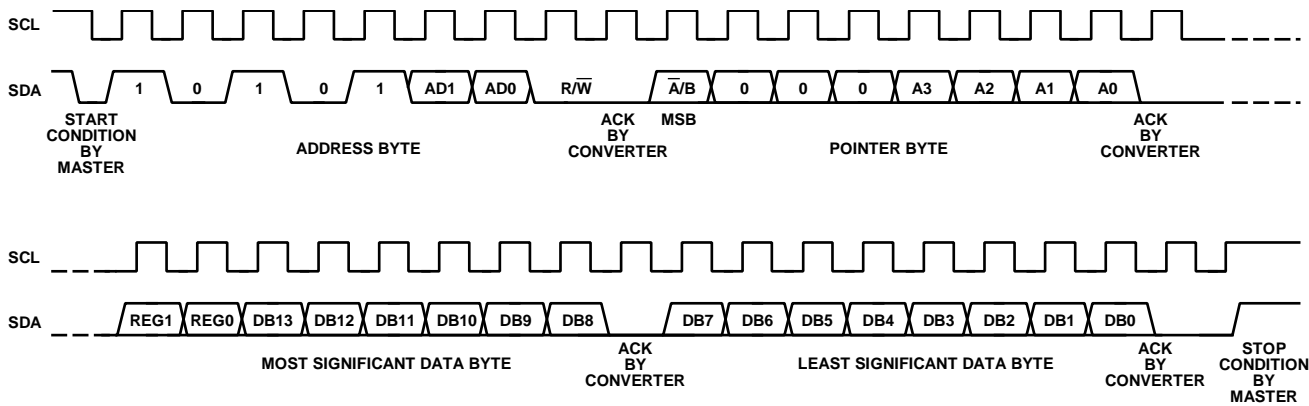

Figure 33. [AD5390/AD5392](#) 4-Byte Mode I<sup>2</sup>C Write Operation

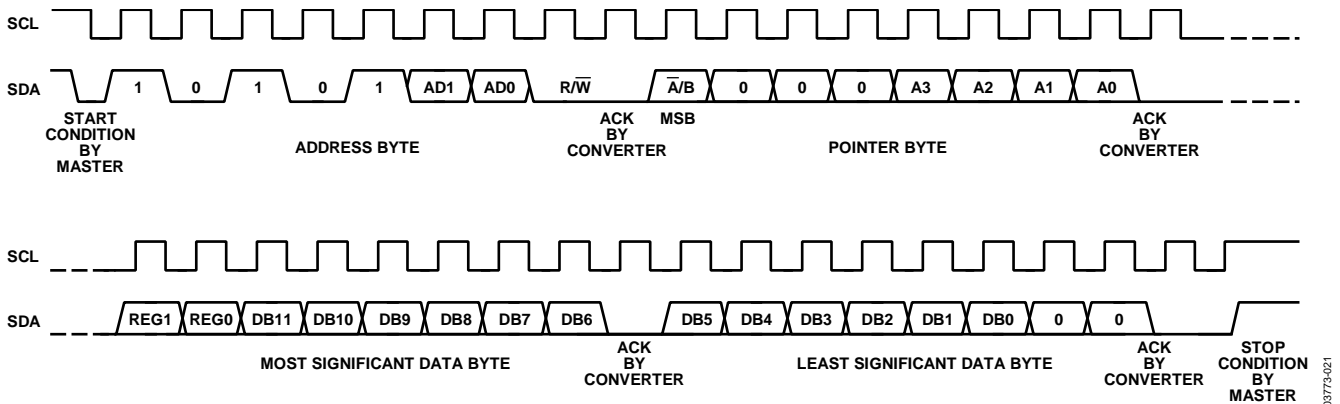

Figure 34. [AD5391](#) 4-Byte Mode I<sup>2</sup>C Write Operation

**3-BYTE MODE**

The 3-byte mode lets the user update more than one channel in a write sequence without having to write the device address byte each time. The device address byte is required only once and subsequent channel updates require the pointer byte and the data bytes. In 3-byte mode, the user begins with an address byte ( $R/\overline{W} = 0$ ) after which the DAC acknowledges that it is prepared to receive data by pulling SDA low. The address byte is followed by the pointer byte; this addresses the specific channel in the DAC to be addressed and is also acknowledged by the DAC. Address Bits A3 to A0 address all channels on the [AD5390/AD5391](#). Address Bits A2 to A0 address all channels on the

[AD5392](#). Address Bit A3 is a zero on the [AD5392](#). This is then followed by the two data bytes. REG1 and REG0 determine the register to be updated.

If a STOP condition is not sent following the data bytes, another channel can be updated by sending a new pointer byte followed by the data bytes. This mode requires only three bytes to be sent to update any channel once the device has been initially addressed and reduces the software overhead in updating the [AD5390/AD5391/AD5392](#) channels. A STOP condition at any time exits this mode. Figure 35 shows a typical configuration.

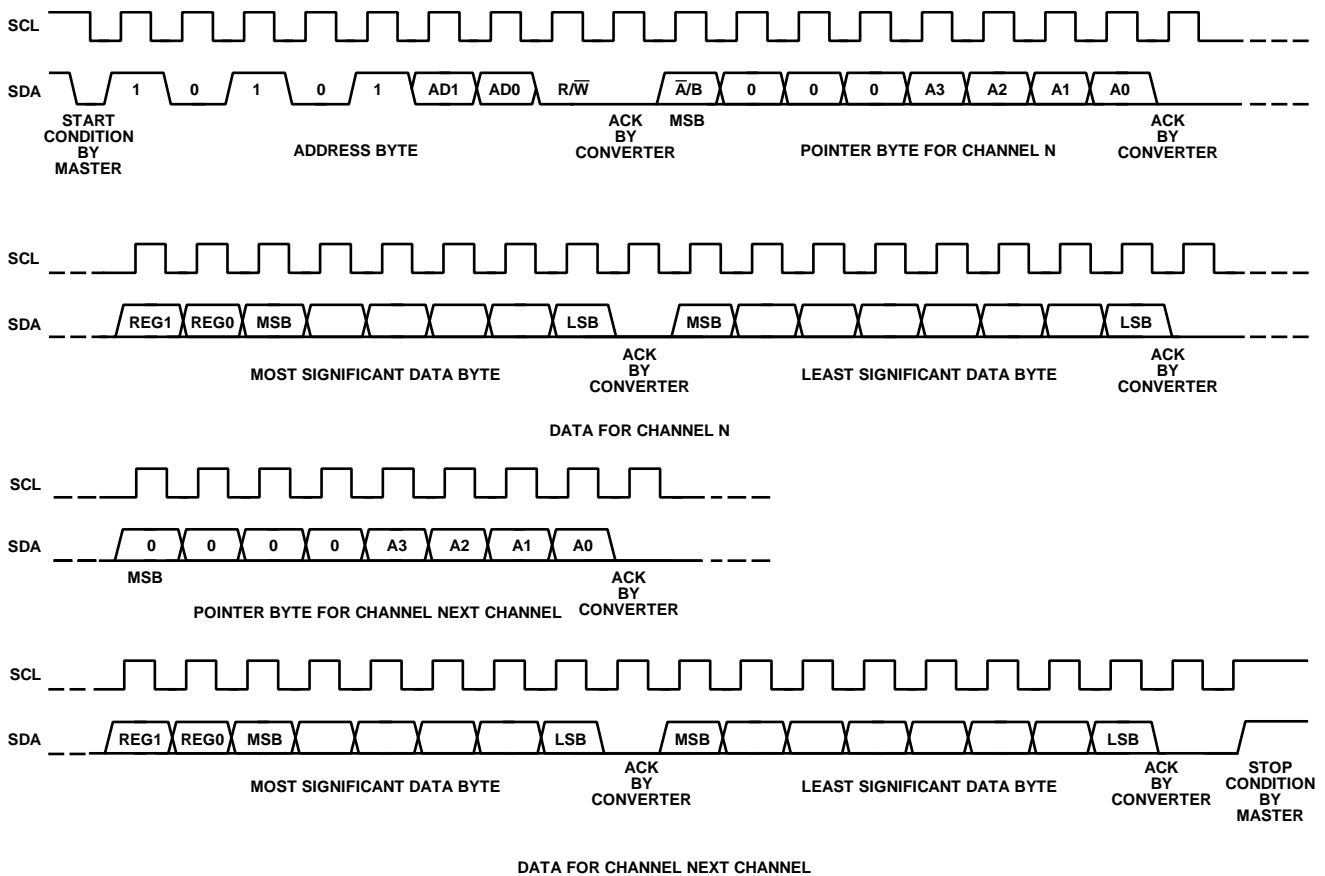

Figure 35. 3-Byte Mode PC Write Operation

037734024

**2-BYTE MODE**

The 2-byte mode lets the user update channels sequentially following initialization of this mode. The device address byte is required only once and the address pointer is configured for autoincrement or burst mode.

The user must begin with an address byte ( $R/\overline{W} = 0$ ), after which the DAC acknowledges that it is prepared to receive data by pulling SDA low. The address byte is followed by a specific pointer byte (0xFF), which initiates the burst mode of operation. The address pointer initializes to Channel 0 and the data following the pointer is loaded to Channel 0. The address pointer automatically increments to the next address.

The REG0 and REG1 bits in the data byte determine the register to be updated. In this mode, following the initialization, only the two data bytes are required to update a channel. The channel address automatically increments from Address 0 to the final address and then returns to the normal 3-byte mode of operation. This mode allows transmission of data to all channels in one block and reduces the software overhead in configuring all channels. A STOP condition at any time exits this mode. Toggle mode of operation is not supported in 2-byte mode. Figure 36 shows a typical configuration.

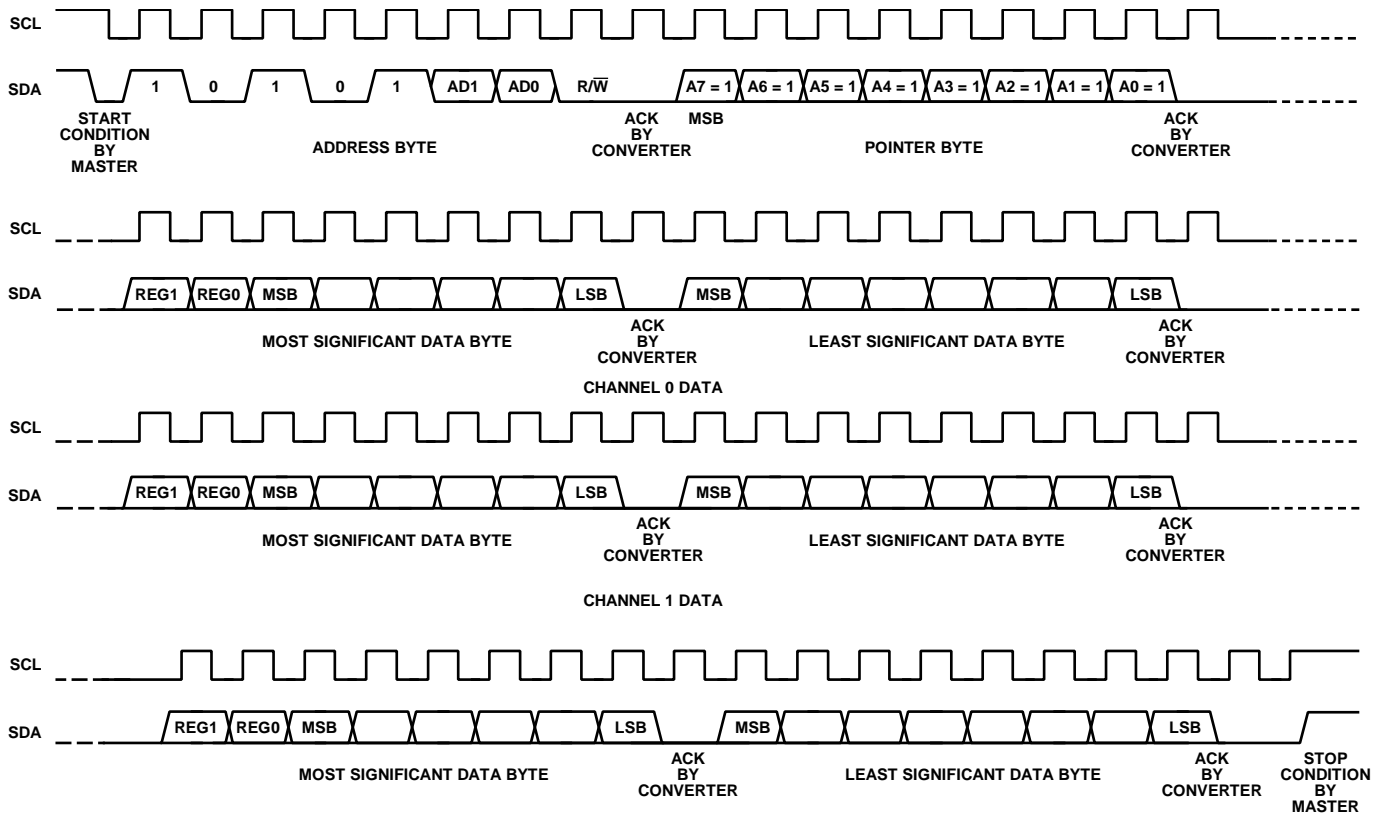

CHANNEL N DATA FOLLOWED BY STOP

Figure 36. 2-Byte Mode I<sup>2</sup>C Write Operation

08773-025

## AD5390/AD5391/AD5392 ON-CHIP SPECIAL FUNCTION REGISTERS

The [AD5390/AD5391/AD5392](#) contain a number of special function registers (SFRs) as shown in Table 21. SFRs are addressed with REG1 = 0 and REG0 = 0 and are decoded using Address Bit A3 to Bit A0.

**Table 21. SFR Register Functions (REG1 = 0, REG0 = 0)**

R/W	A3	A2	A1	A0	Function
X	0	0	0	0	NOP (no operation)
0	0	0	0	1	Write CLR code
0	0	0	1	0	Soft CLR
0	1	0	0	0	Soft power-down
0	1	0	0	1	Soft power-up
0	1	1	0	0	Control register write
1	1	1	0	0	Control register read
0	1	0	1	0	Monitor channel
0	1	1	1	1	Soft reset

### SFR Commands

#### NOP (No Operation)

REG1 = REG0 = 0, A3 to A0 = 0000

Performs no operation, but is useful in readback mode to clock out data on SDO for diagnostic purposes.  $\overline{\text{BUSY}}$  outputs a low during a NOP operation.

#### Write CLR Code

REG1 = REG0 = 0, A3 to A0 = 0001

DB13 to DB0 = Contain the CLR data

Bringing the  $\overline{\text{CLR}}$  line low or exercising the soft clear function loads the contents of the DAC registers with the data contained in the user-configurable CLR register and sets VOUT 0 to VOUT 15, accordingly. This can be very useful not only for setting up a specific output voltage in a clear condition but for calibration purposes. For calibration, the user can load full scale or zero scale to the clear code register and then issue a hardware or software clear to load this code to all DACs, removing the need for individual writes to all DACs. Default on power-up is all zeros.

#### Soft CLR

REG1 = REG0 = 0, A3 to A0 = 0010

DB13 to DB0 = Don't Care

Executing this instruction performs the CLR, which is functionally the same as that provided by the external CLR pin. The DAC outputs are loaded with the data in the CLR code register. The time taken to execute fully the SOFT CLR is 20  $\mu\text{s}$  on the [AD5390/AD5391](#) and 15  $\mu\text{s}$  on the [AD5392](#). It is indicated by the  $\overline{\text{BUSY}}$  low time.

#### Soft Power-Down

REG1 = REG0 = 0, A3 to A0 = 1000

DB13 to DB0 = Don't Care

Executing this instruction performs a global power-down, which puts all channels into a low power mode, reducing analog current to 1  $\mu\text{A}$  maximum and digital power consumption to 20  $\mu\text{A}$  maximum. In power-down mode, the output amplifier can be configured as a high impedance output or can provide a 100 k $\Omega$  load to ground. The contents of all internal registers are retained in power-down mode.

#### Soft Power-Up

REG1 = REG0 = 0, A3 to A0 = 1001

DB13 to DB0 = Don't Care

This instruction is used to power up the output amplifiers and the internal references. The time to exit power-down mode is 8  $\mu\text{s}$ . The hardware power-down and software functions are internally combined in a digital OR function.

#### Soft Reset

REG1 = REG0 = 0, A5 to A0 = 001111

DB13 to DB0 = Don't Care

This instruction is used to implement a software reset. All internal registers are reset to their default values, which correspond to m at full scale and c at zero scale. The contents of the DAC registers are cleared, setting all analog outputs to 0 V. The soft reset activation time is 135  $\mu\text{s}$  maximum. Only perform a soft reset when the [AD5390/AD5391/AD5392](#) is not in power-down mode.

#### Monitor Channel

REG1 = REG0 = 0, A3 to A0 = 01010

DB13 to DB8 = Contain data to address the channel to be monitored

A monitor function is provided on all devices. This feature, consisting of a multiplexer addressed via the interface, allows any channel output to be routed to the MON\_OUT pin for monitoring using an external ADC. In addition to monitoring all output channels, two external inputs are also provided, allowing the user to monitor signals external to the [AD5390/AD5391/AD5392](#). The channel monitor function must be enabled in the control register before any channels are routed to the MON\_OUT pin. On the [AD5390](#) and [AD5392](#) 14-bit parts, DB13 to DB8 contain the channel address for the monitored channel. On the [AD5391](#) 12-bit part, DB11 to DB6 contain the channel address for the channel to be monitored. Selecting Address 63 three-states the MON\_OUT pin.

The channel monitor decoding for the [AD5390/AD5392](#) is shown in Table 22 and the monitor decoding for the [AD5391](#) is shown in Table 23.

Table 22. AD5390/AD5392 Channel Monitor Decoding

REG1	REG0	A3	A2	A1	A0	DB13	DB12	DB11	DB10	DB9	DB8	DB7 to DB0	MON_OUT (AD5390)	MON_OUT (AD5392)
0	0	1	0	1	0	0	0	0	0	0	0	X	VOUT 0	VOUT 0
0	0	1	0	1	0	0	0	0	0	0	1	X	VOUT 1	VOUT 1
0	0	1	0	1	0	0	0	0	0	1	0	X	VOUT 2	VOUT 2
0	0	1	0	1	0	0	0	0	0	1	1	X	VOUT 3	VOUT 3
0	0	1	0	1	0	0	0	0	1	0	0	X	VOUT 4	VOUT 4
0	0	1	0	1	0	0	0	0	1	0	1	X	VOUT 5	VOUT 5
0	0	1	0	1	0	0	0	0	1	1	0	X	VOUT 6	VOUT 6
0	0	1	0	1	0	0	0	0	1	1	1	X	VOUT 7	VOUT 7
0	0	1	0	1	0	0	0	1	0	0	0	X	VOUT 8	
0	0	1	0	1	0	0	0	1	0	0	1	X	VOUT 9	
0	0	1	0	1	0	0	0	1	0	1	0	X	VOUT 10	
0	0	1	0	1	0	0	0	1	0	1	1	X	VOUT 11	
0	0	1	0	1	0	0	0	1	1	0	0	X	VOUT 12	
0	0	1	0	1	0	0	0	1	1	0	1	X	VOUT 13	
0	0	1	0	1	0	0	0	1	1	1	0	X	VOUT 14	
0	0	1	0	1	0	0	0	1	1	1	1	X	VOUT 15	
0	0	1	0	1	0	1	0	0	1	0	0	X	MON_IN 1	MON_IN 1
0	0	1	0	1	0	1	0	0	1	0	1	X	MON_IN 2	MON_IN 2
0	0	1	0	1	0	1	1	1	1	1	1	X	Three-state	Three-state

Table 23. AD5391 Channel Monitor Decoding

REG1	REG0	A3	A2	A1	A0	DB11	DB10	DB9	DB8	DB7	DB6	DB5 to DB0	MON_OUT (AD5391)
0	0	1	0	1	0	0	0	0	0	0	0	X	VOUT 0
0	0	1	0	1	0	0	0	0	0	0	1	X	VOUT 1
0	0	1	0	1	0	0	0	0	0	1	0	X	VOUT 2
0	0	1	0	1	0	0	0	0	0	1	1	X	VOUT 3
0	0	1	0	1	0	0	0	0	1	0	0	X	VOUT 4
0	0	1	0	1	0	0	0	0	1	0	1	X	VOUT 5
0	0	1	0	1	0	0	0	0	1	1	0	X	VOUT 6
0	0	1	0	1	0	0	0	0	1	1	1	X	VOUT 7
0	0	1	0	1	0	0	0	1	0	0	0	X	VOUT 8
0	0	1	0	1	0	0	0	1	0	0	1	X	VOUT 9
0	0	1	0	1	0	0	0	1	0	1	0	X	VOUT 10
0	0	1	0	1	0	0	0	1	0	1	1	X	VOUT 11
0	0	1	0	1	0	0	0	1	1	0	0	X	VOUT 12
0	0	1	0	1	0	0	0	1	1	0	1	X	VOUT 13
0	0	1	0	1	0	0	0	1	1	1	0	X	VOUT 14
0	0	1	0	1	0	0	0	1	1	1	1	X	VOUT 15
0	0	1	0	1	0	1	0	0	1	0	0	X	MON_IN 1
0	0	1	0	1	0	1	0	0	1	0	1	X	MON_IN 2
0	0	1	0	1	0	1	1	0	1	1	0	X	Undefined
0	0	1	0	1	0	1	1	.	.	.	.	X	Undefined
0	0	1	0	1	0	1	1	1	1	1	0	X	Undefined
0	0	1	0	1	0	1	1	1	1	1	1	X	Three-state

**CONTROL REGISTER WRITE**

Table 24 shows the control register contents for the [AD5390](#) and the [AD5392](#). Table 25 provides bit descriptions. Note that REG1 = REG0 = 0, A3 to A0 = 1100, and DB13 to DB0 contain the control register data.

**Table 24. AD5390/AD5392 Control Register Contents**

MSB												LSB	
CR13	CR12	CR11	CR10	CR9	CR8	CR7	CR6	CR5	CR4	CR3	CR2	CR1	CR0

**Table 25. AD5390 and AD5392 Bit Descriptions**

Bit	Description
CR13	Power-Down Status. This bit is used to configure the output amplifier state in power-down mode. CR13 = 1: Amplifier output is high impedance (default on power-up). CR13 = 0: Amplifier output is 100 kΩ to ground.
CR12	REF Select. This bit selects the operating internal reference for the <a href="#">AD5390/AD5391/AD5392</a> . CR12 is programmed as follows: CR12 = 1: Internal reference is 2.5 V ( <a href="#">AD5390-5/AD5392-5</a> default). Recommended operating reference for <a href="#">AD5390-5/AD5391-5/AD5392-5</a> . CR12 = 0: Internal reference is 1.25 V ( <a href="#">AD5390-3/AD5392-3</a> default). Recommended operating reference for <a href="#">AD5390-3 and AD5392-3</a> .
CR11	Current Boost Control. This bit is used to boost the current in the output amplifier, thus altering its slew rate and is configured as follows: CR11 = 1: Boost mode on. This maximizes the bias current in the output amplifier, optimizing its slew rate but increasing the power dissipation. CR11 = 0: Boost mode off (default on power-up). This reduces the bias current in the output amplifier and reduces the overall power consumption.
CR10	Internal/External Reference. This bit determines if the DAC uses its internal reference or an external reference. CR10 = 1: Internal reference enabled. Reference output depends on data loaded to CR12. CR10 = 0: External reference selected (default on power-up).
CR9	Channel Monitor Enable (see Table 22). CR9 = 1: Monitor enabled (default on power-up). This enables the channel monitor function. Following a write to the monitor channel in the SFR register, the selected channel output is routed to the MON_OUT pin. CR9 = 0: Monitor disabled. When monitor is disabled, the MON_OUT pin is three-stated.
CR8	Thermal Monitor Function. When enabled, this function is used to monitor the internal die temperature of the <a href="#">AD5390/AD5392</a> . The thermal monitor powers down the output amplifiers when the temperature exceeds 130°C. This function can be used to protect the device when the power dissipation of the device may be exceeded, if a number of output channels are simultaneously short circuited. A soft power-up re-enables the output amplifiers if the die temperature has dropped below 130°C. CR8 = 1: Thermal monitor enabled. CR8 = 0: Thermal monitor disabled (default on power-up).
CR7 to CR4	Don't Care.
CR3 to CR2	Toggle Function Enable. This function lets the user toggle the output between two codes loaded to the A and B register for each DAC. Control Register Bits CR3 and CR2 are used to enable individual groups of eight channels for operation in toggle mode on the <a href="#">AD5390</a> and <a href="#">AD5392</a> , as follows: CR3    Group 1    Channel 8 to Channel 15 CR2    Group 0    Channel 0 to Channel 7 CR2 is the only active bit on the <a href="#">AD5392</a> . Logic 1 written to any bit enables a group of channels and Logic 0 disables a group. LDAC is used to toggle between the two registers.
CR1 to CR0	Don't Care.

Table 26 shows the control register contents of the [AD5391](#). Table 27 provides bit descriptions. Note that REG1 = REG0 = 0, A3 to A0 = 1100, and DB13 to DB0 contain the control register data.

**Table 26. AD5391 Control Register Contents**

MSB										LSB	
CR11	CR10	CR9	CR8	CR7	CR6	CR5	CR4	CR3	CR2	CR1	CR0

**Table 27. AD5391 Bit Descriptions**

Bit	Description
CR11	Power-Down Status. This bit is used to configure the output amplifier state in power-down mode. CR11 = 1: Amplifier output is high impedance (default on power-up). CR11 = 0: Amplifier output is 100 kΩ to ground.
CR10	REF Select. This bit selects the operating internal reference for the <a href="#">AD5391</a> . CR10 is programmed as follows: CR10 = 1: Internal reference is 2.5 V ( <a href="#">AD5391-5</a> default). Recommended operating reference for <a href="#">AD5391-5</a> . CR10 = 0: Internal reference is 1.25 V ( <a href="#">AD5391-3</a> default). Recommended operating reference for <a href="#">AD5391-3</a> .
CR9	Current Boost Control. This bit is used to boost the current in the output amplifier, thus altering its slew rate. This bit is configured as follows: CR9 = 1: Boost mode on. This maximizes the bias current in the output amplifier, optimizing its slew rate but increasing the power dissipation. CR9 = 0: Boost mode off (default on power-up). This reduces the bias current in the output amplifier and reduces the overall power consumption.
CR8	Internal/External Reference. This bits determines if the DAC uses its internal reference or an external reference. CR8 = 1: Internal reference enabled. Reference output depends on data loaded to CR10. CR8 = 0: External reference selected (default on power-up).
CR7	Channel Monitor Enable (see Table 23). CR7 = 1: Monitor enabled. This enables the channel monitor function. Following a write to the monitor channel in the SFR register, the selected channel output is routed to the MON_OUT pin. CR7 = 0: Monitor disabled (default on power-up). When monitor is disabled, the MON_OUT pin is three-stated.
CR6	Thermal Monitor Function. When enabled, this function is used to monitor the internal die temperature of the <a href="#">AD5391</a> , when enabled. The thermal monitor powers down the output amplifiers when the temperature exceeds 130°C. This function can be used to protect the device in cases where the power dissipation of the device may be exceeded, if a number of output channels are simultaneously short circuited. A soft power-up re-enables the output amplifiers if the die temperature has dropped below 130°C. CR6 = 1: Thermal monitor enabled. CR6 = 0: Thermal monitor disabled (default on power-up).
CR5 to CR2	Don't Care.
CR1 to CR0	Toggle Function Enable. This function lets the user toggle the output between two codes loaded to the A and B register for each DAC. Control Register Bit CR1 and Bit CR0 are used to enable individual groups of eight channels for operation in toggle mode on the <a href="#">AD5391</a> , as follows: CR1   Group 1   Channel 8 to Channel 15 CR0   Group 0   Channel 0 to Channel 7 Logic 1 written to any bit enables a group of channels and Logic 0 disables a group. $\overline{\text{LDAC}}$ is used to toggle between the two registers.

## HARDWARE FUNCTIONS

### RESET FUNCTION

Bringing the  $\overline{\text{RESET}}$  line low resets the contents of all internal registers to their power-on reset state.  $\overline{\text{RESET}}$  is a negative edge-sensitive input. The default corresponds to  $m$  at full scale and  $c$  at zero scale. The contents of all DAC registers are cleared by setting the outputs to 0 V. This sequence takes 270  $\mu\text{s}$  maximum. The falling edge of  $\overline{\text{RESET}}$  initiates the reset process.  $\overline{\text{BUSY}}$  goes low for the duration, returning high when  $\overline{\text{RESET}}$  is complete. While  $\overline{\text{BUSY}}$  is low, all interfaces are disabled and all  $\overline{\text{LDAC}}$  pulses are ignored. When  $\overline{\text{BUSY}}$  returns high, the part resumes normal operation, and the status of the  $\overline{\text{RESET}}$  pin is ignored until the next falling edge is detected. Only perform a hardware reset when the AD5390/AD5391/AD5392 is not in power-down mode.

### ASYNCHRONOUS CLEAR FUNCTION

$\overline{\text{CLR}}$  is negative-edge-triggered and  $\overline{\text{BUSY}}$  goes low for the duration of the  $\overline{\text{CLR}}$  execution. Bringing the  $\overline{\text{CLR}}$  line low clears the contents of the DAC registers to the data contained in the user-configurable  $\overline{\text{CLR}}$  register and sets the analog outputs accordingly. This function can be used in system calibration to load zero scale and full scale to all channels together. The execution time for a  $\overline{\text{CLR}}$  is 20  $\mu\text{s}$  on the AD5390/AD5391 and 15  $\mu\text{s}$  on the AD5392.

### BUSY AND LDAC FUNCTIONS

$\overline{\text{BUSY}}$  is a digital CMOS output indicating the status of the AD5390/AD5391/AD5392 devices.  $\overline{\text{BUSY}}$  goes low during internal calculations of x2 data. If  $\overline{\text{LDAC}}$  is taken low while  $\overline{\text{BUSY}}$  is low, this event is stored. The user can hold the  $\overline{\text{LDAC}}$  input permanently low and, in this case, the DAC outputs update immediately after  $\overline{\text{BUSY}}$  goes high.  $\overline{\text{BUSY}}$  also goes low during a power-on reset and when a falling edge is detected on the  $\overline{\text{RESET}}$  pin. During this time, all interfaces are disabled and any events on  $\overline{\text{LDAC}}$  are ignored.

The AD5390/AD5391/AD5392 contain an extra feature whereby a DAC register is not updated unless its x2 register has been written to since the last time  $\overline{\text{LDAC}}$  was brought low. Normally, when  $\overline{\text{LDAC}}$  is brought low, the DAC registers are filled with the contents of the x2 registers. However, these devices update the DAC register only if the x2 data has changed, thereby removing unnecessary digital crosstalk.

### POWER-ON RESET

The AD5390/AD5391/AD5392 contain a power-on reset generator and state machine. The power-on reset resets all registers to a predefined state, and the analog outputs are configured as high impedance outputs. The  $\overline{\text{BUSY}}$  pin goes low during the power-on reset sequence, preventing data writes to the device.

### POWER-DOWN

The AD5390/AD5391/AD5392 contain a global power-down feature that puts all channels into a low power mode, reducing the analog power consumption to 1  $\mu\text{A}$  maximum and the digital power consumption to 20  $\mu\text{A}$  maximum. In power-down mode, the output amplifier can be configured as a high impedance output or to provide a 100 k $\Omega$  load to ground. The contents of all internal registers are retained in power-down mode. When exiting power-down, the settling time of the amplifier elapses before the outputs settle to their correct value.

### MICROPROCESSOR INTERFACING

#### AD5390/AD5391/AD5392 to MC68HC11

The serial peripheral interface (SPI) on the MC68HC11 is configured for master mode (MSTR = 1), clock polarity bit (CPOL) = 0, and the clock phase bit (CPHA) = 1. The SPI is configured by writing to the SPI control register (SPCR)—see the 68HC11 User Manual. SCK of the MC68HC11 drives the SCLK of the AD5390/AD5391/AD5392, the MOSI output drives the serial data line (DIN) of the AD5390/AD5391/AD5392, and the MISO input is driven from  $\overline{\text{DOUT}}$ . The  $\overline{\text{SYNC}}$  signal is derived from a port line (PC7). When data is being transmitted to the AD5390/AD5391/AD5392, the  $\overline{\text{SYNC}}$  line is taken low (PC7). Data appearing on the MOSI output is valid on the falling edge of SCK. Serial data from the MC68HC11 is transmitted in 8-bit bytes with only eight falling clock edges occurring in the transmit cycle.

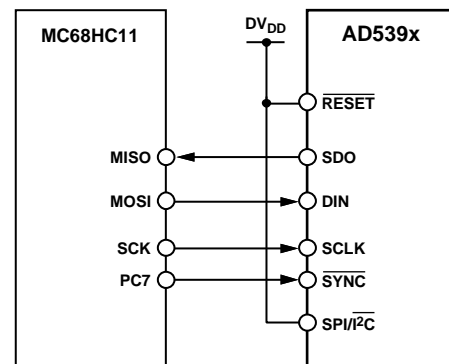

Figure 37. AD5390/AD5391/AD5392 to MC68HC11 Interface

**AD5390/AD5391/AD5392 to PIC16C6x/7x**

The PIC16C6x/7x synchronous serial port (SSP) is configured as an SPI master with the clock polarity bit = 0. This is done by writing to the synchronous serial port control register (SSPCON)—see the PIC16/17 Microcontroller User Manual. In Figure 38, I/O port RA1 is used to pulse SYNC and enable the serial port of the AD5390/AD5391/AD5392. This microcontroller transfers only eight bits of data during each serial transfer operation; therefore, three consecutive read/write operations are needed, depending on the mode. Figure 38 shows the connection diagram.

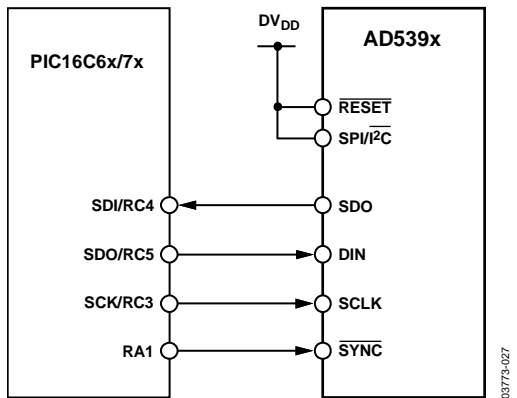

Figure 38. AD5390/AD5391/AD5392 to PIC16C6x/7x Interface

**AD5390/AD5391/AD5392 to 8051**

The AD5390/AD5391/AD5392 requires a clock synchronized to the serial data. The 8051 serial interface must, therefore, be operated in Mode 0. In this mode, serial data enters and exits through RxD and a shift clock is output on TxD. Figure 39 shows how the 8051 is connected to the AD5390/AD5391/AD5392. Because the AD5390/AD5391/AD5392 shifts data out on the rising edge of the shift clock and latches data in on the falling edge, the shift clock must be inverted. The AD5390/AD5391/AD5392 requires its data with the MSB first. Because the 8051 outputs the LSB first, the transmit routine must take this into account.

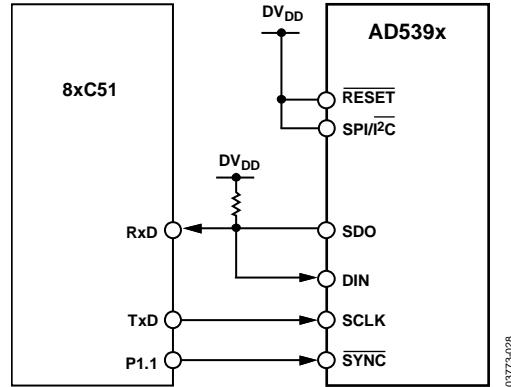

Figure 39. AD5390/AD5391/AD5392 to 8051 Interface

**AD5390/AD5391/AD5392 to ADSP-BF527**

Figure 40 shows a serial interface between the AD5390/AD5391/AD5392 and the ADSP-BF527. The ADSP-BF527 should be set up to operate in SPORT transmit alternate framing mode. The ADSP-BF527 SPORT is programmed through the SPORT control register and should be configured as follows: internal clock operation, active low framing, and 16-bit word length. Transmission is initiated by writing a word to the Tx register after the SPORT has been enabled.

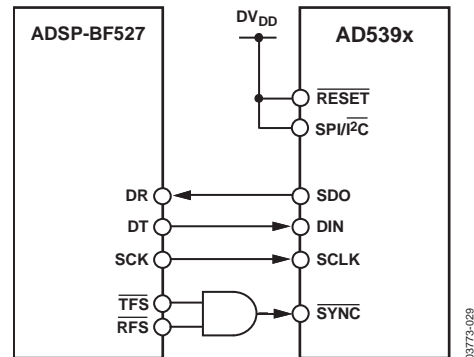

Figure 40. AD5390/AD5391/AD5392 to ADSP-BF527 Interface

## APPLICATION INFORMATION

### POWER SUPPLY DECOUPLING

In any circuit where accuracy is important, careful consideration of the power supply and ground return layout helps to ensure the rated performance. The printed circuit board on which the [AD5390/AD5391/AD5392](#) is mounted should be designed so that the analog and digital sections are separated and confined to certain areas of the board. If the [AD5390/AD5391/AD5392](#) is in a system where multiple devices require an AGND-to-DGND connection, the connection should be made at one point only. The star ground point should be established as close as possible to the device.

For supplies with multiple pins ( $AV_{DD}$ ,  $AV_{CC}$ ), it is recommended to tie those pins together. The [AD5390/AD5391/AD5392](#) should have ample supply bypassing of 10  $\mu\text{F}$  in parallel with 0.1  $\mu\text{F}$  on each supply located as close to the package as possible—ideally right up against the device. The 10  $\mu\text{F}$  capacitors are the tantalum bead type. The 0.1  $\mu\text{F}$  capacitor should have low effective series resistance (ESR) and effective series inductance (ESI), such as the common ceramic types that provide a low impedance path to ground at high frequencies, to handle transient currents due to internal logic switching.

The power supply lines of the [AD5390/AD5391/AD5392](#) should use as large a trace as possible to provide low impedance paths and reduce the effects of glitches on the power supply line. Fast switching signals such as clocks should be shielded with digital ground to avoid radiating noise to other parts of the board, and should never run near the reference inputs. A ground line routed between the DIN and SCLK lines helps reduce crosstalk between them (not required on a multilayer board, because there is a separate ground plane, but separating the lines helps).

Avoid crossover of digital and analog signals. Traces on opposite sides of the board should run at right angles to each other. This reduces the effects of feedthrough through the board. A micro-strip technique is by far the best, but not always possible with a double-sided board. In this technique, the component side of the board is dedicated to ground plane, while signal traces are placed on the soldered side.

## POWER SUPPLY SEQUENCING

For proper operation, apply  $DV_{DD}$  first and  $AV_{DD}$  simultaneously or within 10 ms of  $DV_{DD}$ . This ensures that the power on reset circuitry sets the registers to their default values and keeps the analog outputs at 0 V until a valid write operation takes place. When  $AV_{DD}$  cannot be applied within 10 ms of  $DV_{DD}$ , issue a hardware reset. This will trigger the power on reset circuitry and load the default register values. In cases where the initial power supply has the same or a lower voltage than the second power supply, a Schottky diode can be used to temporarily supply power until the second power supply turns on. Table 28 lists power supply sequences and the recommended diode connections. Alternatively, a load switch such as the [ADP196](#) can be used to delay the first power supply until the second power supply turns on. Figure 43 shows a typical configuration using the [ADP196](#). In this case, the  $AV_{DD}$  is applied first. This voltage does not appear at the  $AV_{DD}$  pin of the [AD5390/AD5391/AD5392](#) until the  $DV_{DD}$  is applied and brings the EN pin high. The result is that the  $AV_{DD}$  and  $DV_{DD}$  are both applied to the [AD5390/AD5391/AD5392](#) at the same time.

**Table 28. Power Supply Sequencing**

First Power Supply	Second Power Supply	Recommended Operation
$AV_{DD} = 3\text{ V}$	$DV_{DD} \geq 3\text{ V}$	See Figure 41.
$DV_{DD} = 3\text{ V}$	$AV_{DD} \geq 3\text{ V}$	See Figure 42.
$AV_{DD} = DV_{DD}$	$DV_{DD} = AV_{DD}$	See Figure 41; assumes separate analog and digital supplies.
$DV_{DD} = AV_{DD}$	$AV_{DD} = DV_{DD}$	See Figure 42; assumes separate analog and digital supplies
$AV_{DD} = 5\text{ V}$	$DV_{DD} = 3\text{ V}$	See Figure 43
$DV_{DD} = 5\text{ V}$	$AV_{DD} = 3\text{ V}$	Hardware reset or see Figure 44

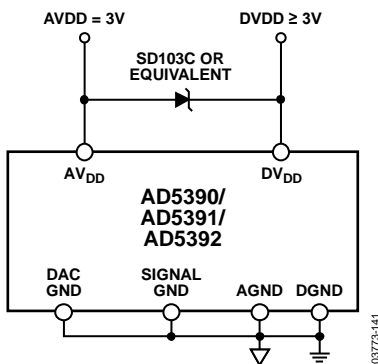

Figure 41.  $AV_{DD}$  first followed by  $DV_{DD}$

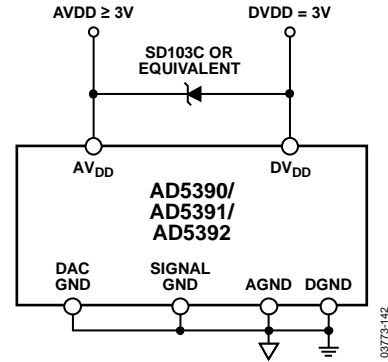

Figure 42.  $DV_{DD}$  first followed by  $AV_{DD}$

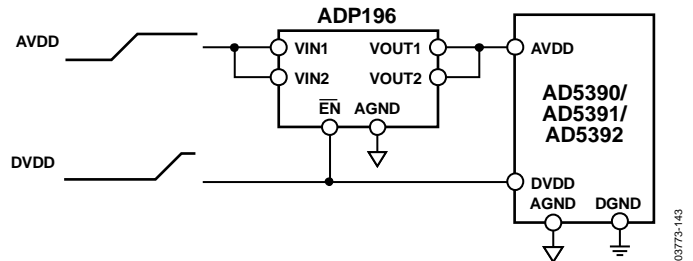

Figure 43.  $AV_{DD}$  Power Supply Controlled by a Load Switch

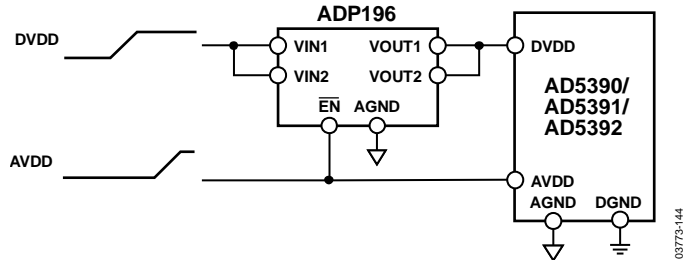

Figure 44.  $DV_{DD}$  Power Supply Controlled by a Load Switch

**TYPICAL CONFIGURATION CIRCUIT**

Figure 45 shows a typical configuration for the AD5390/AD5391/AD5392 when configured for use with an external reference. In the circuit shown, all AGND, SIGNAL\_GND, and DAC\_GND pins are tied together to a common AGND. AGND and DGND are connected together at the AD5390/AD5391/AD5392 device. On power-up, the AD5390/AD5391/AD5392 defaults to external reference operation. All AV<sub>DD</sub> lines are connected together and driven from the same 5 V source. It is recommended to decouple close to the device with a 0.1 μF ceramic and a 10 μF tantalum capacitor. In this application, the reference for the AD5390-5/AD5391-5/AD5392-5 is provided externally from either an ADR421 or ADR431 2.5 V reference.

Suitable external references for the AD5390-3/AD5391-3/AD5392-3 include the ADR280 1.2 V reference. The reference should be decoupled at the REFOUT/REFIN pin of the device with a 0.1 μF capacitor.

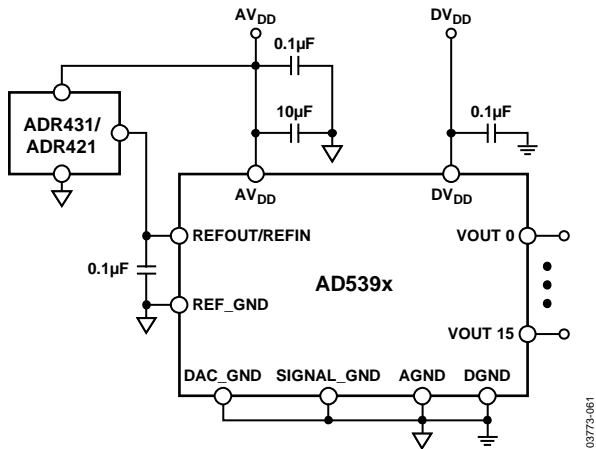

Figure 45. Typical Configuration with External Reference

Figure 46 shows a typical configuration when using the internal reference. On power-up, the AD5390/AD5391/AD5392 defaults to an external reference; therefore, the internal reference needs to be configured and turned on via a write to the AD5390/AD5391/AD5392 control register. On the AD5390/AD5392, Control Register Bit CR12 lets the user choose the reference voltage; Bit CR10 is used to select the internal reference. It is recommended to use the 2.5 V reference when AV<sub>DD</sub> = 5 V, and the 1.25 V reference when AV<sub>DD</sub> = 3 V. On the AD5391, Control Register Bit CR10 lets the user choose the reference voltage; Bit CR8 is used to select the internal reference.

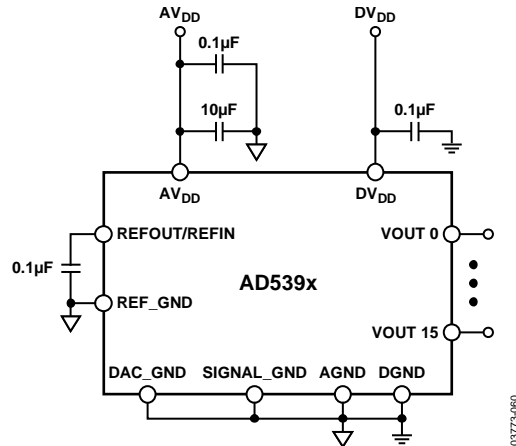

Figure 46. Typical Configuration with Internal Reference. (Digital Connections Omitted for Clarity)

The AD5390/AD5391/AD5392 contains an internal power-on reset circuit with a 10 ms brown-out time. If the power supply ramp rate exceeds 10 ms, the user should reset the AD5390/AD5391/AD5392 as part of the initialization process to ensure the calibration data is loaded correctly into the device.



**Power Amplifier Control**

Multistage power amplifier designs require a large number of setpoints in the operation and control of the output stage. The AD5390/AD5391/AD5392 are ideal for these applications because of their small size (LFCSP) and the integration of 8 and 16 channels, offering 12- and 14-bit resolution. Figure 49 shows a typical transmitter architecture, in which the AD5390/AD5391/AD5392 DACs can be used in the following control circuits:  $I_{BIAS}$  control, average power control (APC), peak power control (PPC), transmit gain control (TGC), and audio level control (ALC). DACs are also required for variable voltage attenuators, phase shifter control, and dc-setpoint control in the overall amplifier design.

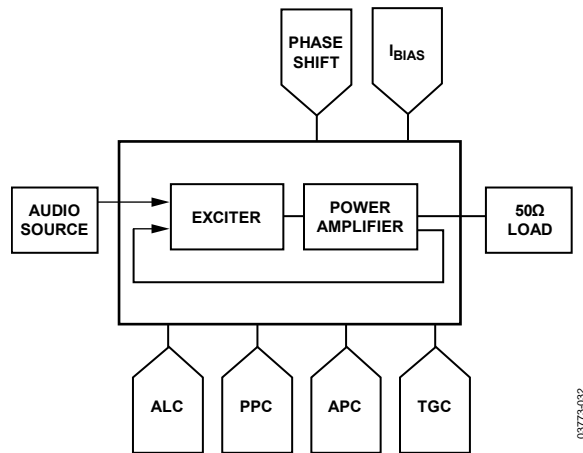

Figure 49. Multistage Power Amplifier Control

**Process Control Applications**

The AD5390-5/AD5391-5/AD5392-5 are ideal for process control applications because it offers a combination of 8 and 16 channels and 12-bit and 14-bit resolution. These applications generally require output voltage ranges of 0 V to 5 V ± 5 V, 0 V to 10 V ± 10 V, and current sink and source functions. The AD5390-5/AD5391-5/AD5392-5 operate from a single 5 V supply and, therefore, require external signal conditioning to achieve the output ranges described here. Figure 50 shows configurations to achieve these output ranges. The key advantages of using AD5390-5/AD5391-5/AD5392-5 in these applications are small package size, pin compatibility with the ability to upgrade from 12 to 14 bits, integrated on-chip 2.5 V reference with 10 ppm/°C maximum temperature coefficient, and excellent accuracy specifications. The AD5390-5/AD5391-5/AD5392-5 contain an offset and gain register for each channel, so users can perform system-level calibration on a per-channel basis.

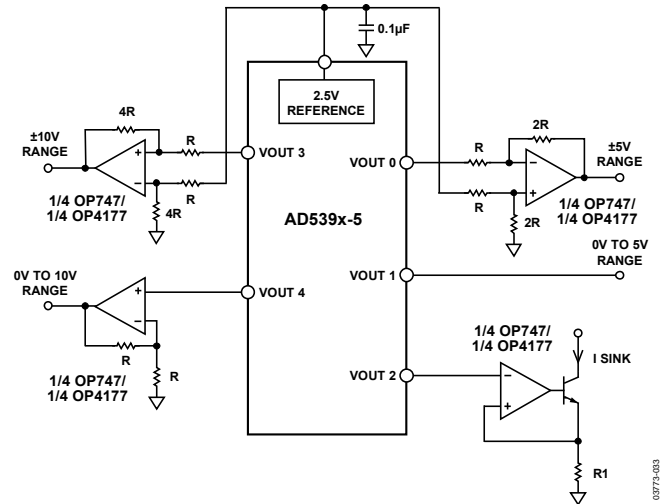

Figure 50. Output Configurations for Process Control Applications

**Optical Transceivers**

The AD5390-3/AD5391-3/AD5392-3 are ideally suited to optical transceiver applications. In 300-pin MSA applications, for example, digital-to-analog converters are required to control the laser power, APD bias, and modulator amplitude. Diagnostic information is required as analog outputs from the module. The AD5390-3/AD5391-3/AD5392-3 offer a combination of 8/16 channels, a resolution of 12/14 bits in a 64-lead LFCSP, and operate from a supply voltage of 2.7 V to 5.5 V supply with internal reference. The AD5390-3/AD5391-3/AD5392-3 also feature I<sup>2</sup>C-compatible and SPI inter-faces, making them ideal components for use in these applications. Figure 51 shows a typical configuration in an optical transceiver application.

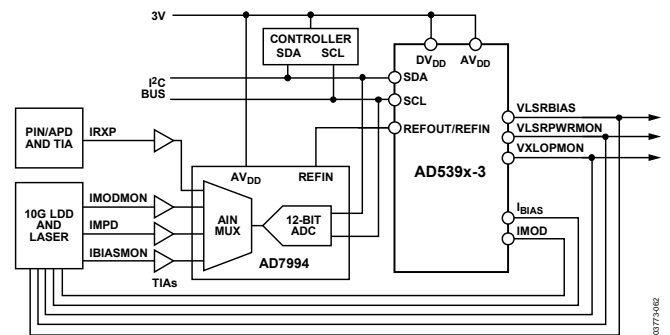
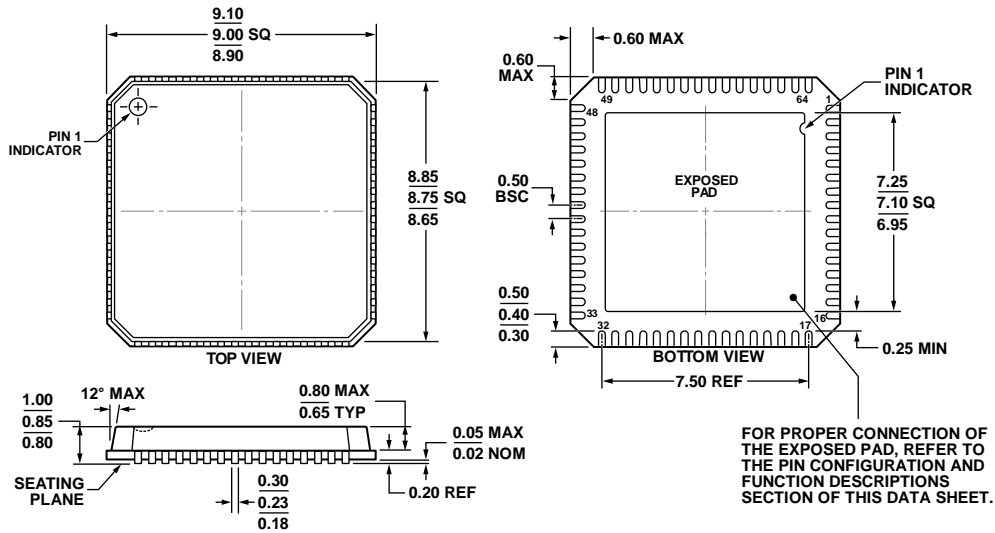

Figure 51. Optical Transceiver using the AD5390-3/AD5391-3/AD5392-3

OUTLINE DIMENSIONS



COMPLIANT TO JEDEC STANDARDS MO-220-VMM4-4

Figure 52. 64-Lead Lead Frame Chip Scale Package [LFCSP\_VQ]  
9 mm x 9 mm Body, Very Thin Quad  
(CP-64-3)

Dimensions shown in millimeters

06-13-2012-C

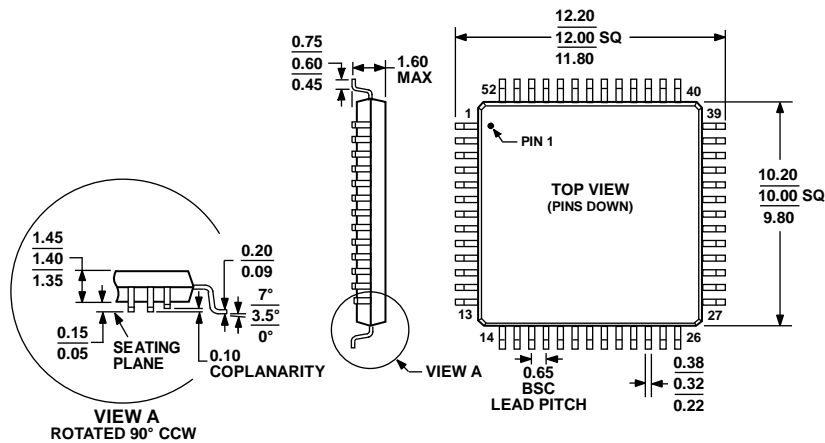

COMPLIANT TO JEDEC STANDARDS MS-026-BCC

Figure 53. 52-Lead Low Profile Quad Flat Package [LQFP]  
(ST-52)

Dimensions shown in millimeters

051706-A

## ORDERING GUIDE

Model <sup>1</sup>	Temperature Range	Resolution	AV <sub>DD</sub>	Output Channels	Linearity Error (LSBs)	Package Description	Package Option
AD5390BCPZ-3	−40°C to +85°C	14-bit	2.7 V to 3.6 V	16	±4	64-Lead LFCSP_VQ	CP-64-3
AD5390BCPZ-3-REEL	−40°C to +85°C	14-bit	2.7 V to 3.6 V	16	±4	64-Lead LFCSP_VQ	CP-64-3
AD5390BCPZ-3-REEL7	−40°C to +85°C	14-bit	2.7 V to 3.6 V	16	±4	64-Lead LFCSP_VQ	CP-64-3
AD5390BCPZ-5	−40°C to +85°C	14-bit	4.5 V to 5.5 V	16	±3	64-Lead LFCSP_VQ	CP-64-3
AD5390BCPZ-5-REEL	−40°C to +85°C	14-bit	4.5 V to 5.5 V	16	±3	64-Lead LFCSP_VQ	CP-64-3
AD5390BCPZ-5-REEL7	−40°C to +85°C	14-bit	4.5 V to 5.5 V	16	±3	64-Lead LFCSP_VQ	CP-64-3
AD5390BSTZ-3	−40°C to +85°C	14-bit	2.7 V to 3.6 V	16	±4	52-Lead LQFP	ST-52
AD5390BSTZ-5	−40°C to +85°C	14-bit	4.5 V to 5.5 V	16	±3	52-Lead LQFP	ST-52
AD5391BCPZ-3	−40°C to +85°C	12-bit	2.7 V to 3.6 V	16	±1	64-Lead LFCSP_VQ	CP-64-3
AD5391BCPZ-5	−40°C to +85°C	12-bit	4.5 V to 5.5 V	16	±1	64-Lead LFCSP_VQ	CP-64-3
AD5391BCPZ-5-REEL	−40°C to +85°C	12-bit	4.5 V to 5.5 V	16	±1	64-Lead LFCSP_VQ	CP-64-3
AD5391BCPZ-5-REEL7	−40°C to +85°C	12-bit	4.5 V to 5.5 V	16	±1	64-Lead LFCSP_VQ	CP-64-3
AD5391BSTZ-3	−40°C to +85°C	12-bit	2.7 V to 3.6 V	16	±1	52-Lead LQFP	ST-52
AD5391BSTZ-5	−40°C to +85°C	12-bit	4.5 V to 5.5 V	16	±1	52-Lead LQFP	ST-52
AD5392BCPZ-3	−40°C to +85°C	14-bit	2.7 V to 3.6 V	8	±4	64-Lead LFCSP_VQ	CP-64-3
AD5392BCPZ-5	−40°C to +85°C	14-bit	4.5 V to 5.5 V	8	±3	64-Lead LFCSP_VQ	CP-64-3
AD5392BSTZ-3	−40°C to +85°C	14-bit	2.7 V to 3.6 V	8	±4	52-Lead LQFP	ST-52
AD5392BSTZ-5	−40°C to +85°C	14-bit	4.5 V to 5.5 V	8	±3	52-Lead LQFP	ST-52
EVAL-AD5390SDZ						Evaluation Board	
EVAL-AD5392SDZ						Evaluation Board	

<sup>1</sup>Z = RoHS Compliant Part.

**NOTES**

Purchase of licensed I<sup>2</sup>C components of Analog Devices or one of its sublicensed Associated Companies conveys a license for the purchaser under the Philips I<sup>2</sup>C Patent Rights to use these components in an I<sup>2</sup>C system, provided that the system conforms to the I<sup>2</sup>C Standard Specification as defined by Philips.

## Looking for pricing, stock, or lifecycle information?

Click below to explore more details on WIN SOURCE:

 [View AD5391BCPZ-3 on WIN SOURCE](#)

 [Analog Devices Inc. Information](#)

## Optimize Your Supply Chain with WIN SOURCE Solutions

-  Global Sourcing Solution
-  Obsolete Management
-  Cost Control Management
-  Shortage Management
-  Alternative Solution
-  Excess Inventory Management