



**THE DATASHEET OF
CYV270M0101EQ-SXC**



Adaptive Video Cable Equalizer

Features

- Adaptive cable equalization
- SMPTE 259M compliant
- Supports DVB-ASI at 270 Mbps
- Multi standard operation from 143 Mbps to 360 Mbps
- Cable length indicator for SD-SDI data rates
- Maximum cable length adjustment for SD-SDI data rates
- Carrier detect and mute functionality for SD-SDI data rates
- Equalizer bypass mode
- Seamless connection with HOTLink II™ family and HOTLink® receiver
- Equalizes up to 350m of Canare L-5CFB and Belden 1694A coaxial cable at 270 Mbps
- Low power 160 mW at 3.3V
- Single 3.3V supply
- 16-pin SOIC
- 0.18 μm CMOS technology
- Pb-free and RoHS compliant
- Uses Cypress CLEANLink™ technology
- Pin compatible to existing equalizer devices

Functional Description

The CYV270M0101EQ is an adaptive video cable equalizer designed to equalize and restore signals received over 75Ω coaxial cable. The equalizer meets SMPTE 259M data rates and is optimized for performance at 270 Mbps. The CYV270M0101EQ is optimized to equalize up to 350m of Canare L-5CFB and Belden 1694A coaxial cable at 270 Mbps. The CYV270M0101EQ connects seamlessly to the HOTLink II family of transceivers and HOTLink receivers.

The CYV270M0101EQ has DC restoration for compensation of the DC content of the SMPTE pathological patterns. A cable length indicator (CLI) provides an indication of the cable length equalized at SD-SDI data rates. The maximum cable length adjust (MCLADJ) sets the approximate maximum cable length to equalize. The CYV270M0101EQ differential serial outputs (SDO, $\overline{\text{SDO}}$) mute when the approximate cable length set by MCLADJ is reached. CD/MUTE is a bidirectional pin that provides an indication of the signal present at the equalizer inputs. It also controls muting the outputs of the equalizer.

Power consumption is typically 160 mW at 3.3V.

Equalizer System Connection Diagram

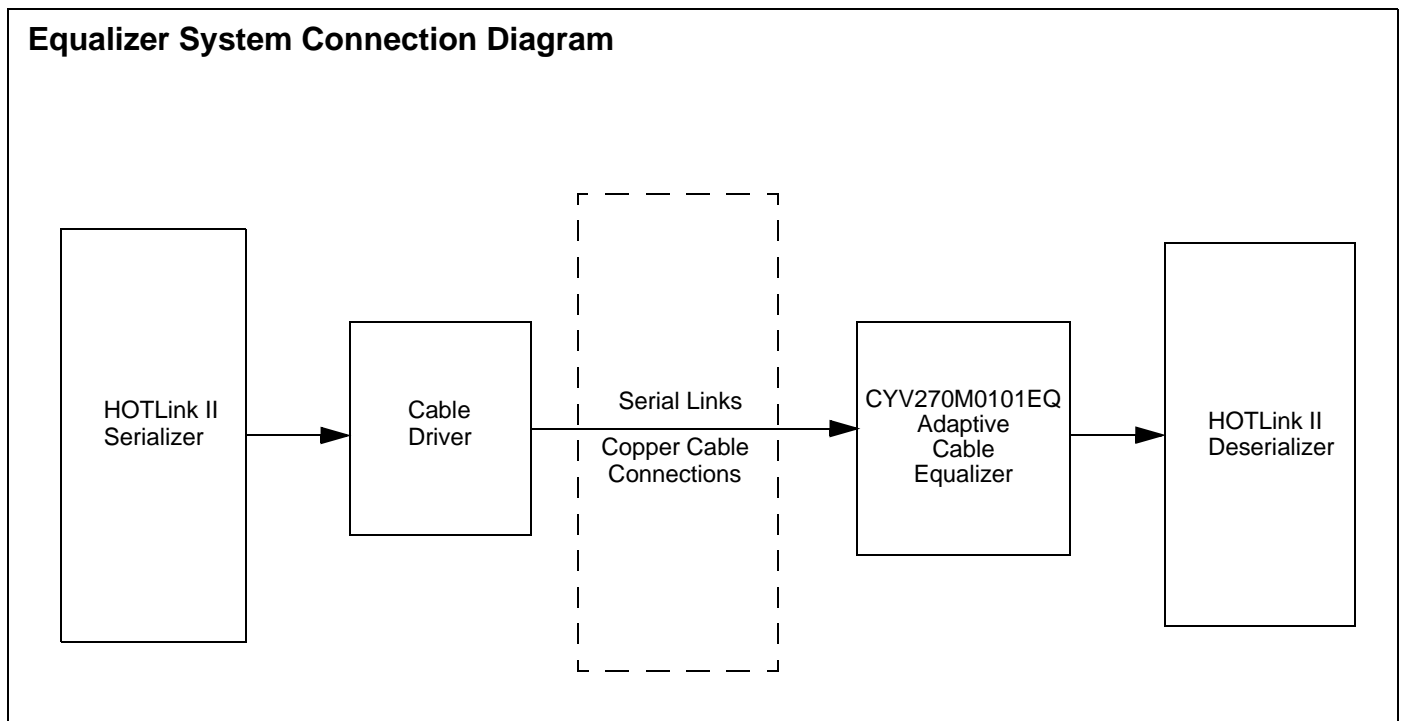

Equalizer Block Diagram

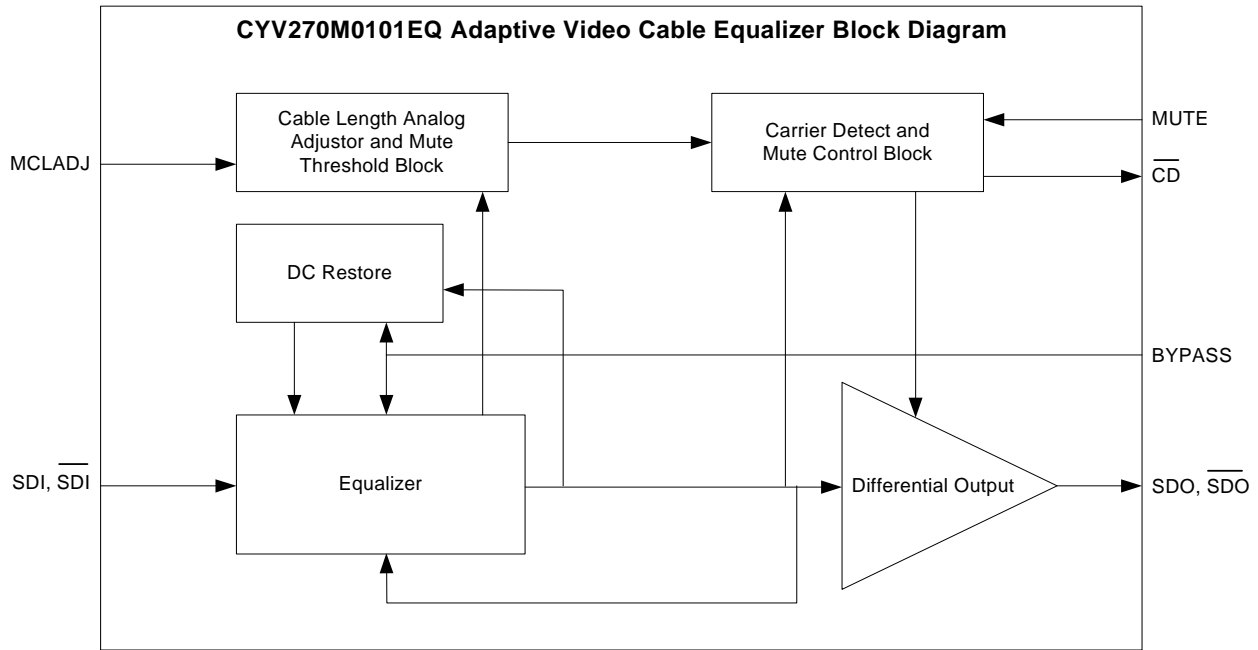

Pinouts

Figure 1. Pin Diagram - 16 Pin SOIC (Top View)

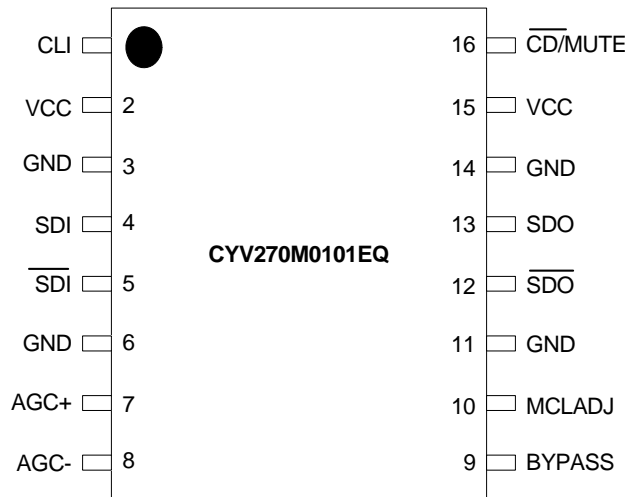

Table 1. Pin Descriptions - CYV270M0101EQ Single Channel Cable Equalizer

| Name | IO Characteristics | Signal Description |
|------------------------------------|---------------------|--|
| Control Signals | | |
| CLI | Analog Output | Cable Length Indicator. CLI provides an analog voltage proportional to the equalized cable length. |
| $\overline{\text{CD}}/\text{MUTE}$ | LVTTTL IO | <p>Carrier Detect/Mute Indicator.</p> <p>Output:</p> <p>When the incoming data stream is present and the cable length does not exceed that set by MCLADJ, the $\overline{\text{CD}}/\text{MUTE}$ outputs a voltage less than 0.8V.</p> <p>When the incoming data stream is not present or the cable length exceeds that set by MCLADJ, the $\overline{\text{CD}}/\text{MUTE}$ outputs a voltage greater than 2.8V.</p> <p>Input:</p> <p>When the $\overline{\text{CD}}/\text{MUTE}$ pin is set LOW, the equalizer's differential serial outputs are not muted.</p> <p>When the $\overline{\text{CD}}/\text{MUTE}$ pin is set HIGH, the equalizer's differential serial outputs are muted.</p> |
| MCLADJ | Analog Input | <p>Maximum Cable Length Adjust. The maximum equalized cable length is set by the voltage applied to the MCLADJ input. When the maximum cable length set by MCLADJ is reached, CD is driven high and the differential output is muted.</p> <p>If MCLADJ functionality is not needed, this pin should be left floating or tied to ground to allow maximum equalized cable length.</p> |
| BYPASS | LVTTTL Input | <p>Equalizer Bypass. When BYPASS is set HIGH, the signal presented at the equalizer's differential serial inputs (SDI, $\overline{\text{SDI}}$) is routed to the equalizer's differential serial outputs (SDO, $\overline{\text{SDO}}$) without equalizing.</p> <p>When BYPASS is set LOW, the incoming video data stream is equalized and presented at the equalizer's serial differential outputs (SDO, $\overline{\text{SDO}}$).</p> <p>In equalizer bypass mode, $\overline{\text{CD}}/\text{MUTE}$ is not functional.</p> |
| AGC \pm | Analog | Automatic Gain Control. Place a capacitor of 1 μF between the AGC \pm pins. |
| SDO, $\overline{\text{SDO}}$ | Differential Output | Differential Serial Outputs. The equalized serial video data stream is presented at the SDO/ $\overline{\text{SDO}}$ differential serial CML output. |
| SDI, $\overline{\text{SDI}}$ | Differential Input | Differential Serial Inputs. SDI/ $\overline{\text{SDI}}$ accepts either a single-ended or differential serial video data stream over 75 Ω coaxial cable. |
| Power | | |
| VCC | Power | +3.3V Power. |
| GND | Gnd | Connect to Ground. |

Equalizer Operation

The CYV270M0101EQ is an adaptive video cable equalizer designed to equalize standard definition (SD) serial digital interface (SDI) video data streams. The CYV270M0101EQ equalizer is optimized to equalize up to 350m of Canare L-5CFB and Belden 1694A cable at 270 Mbps. The device contains one power supply and typically consumes 160 mW power at 3.3V. The adaptive equalizer meets the SMPTE 259M and DVB-ASI video standards. It meets all pathological requirements for SMPTE 259M as defined by RP178. The CYV270M0101EQ Video Cable Equalizer is auto adaptive from 143 Mbps to 360 Mbps.

The CYV270M0101EQ equalizer has variable gain and multiple equalization stages that reverse the effects of the cable. This equalization is achieved by separate regulation of the lower and higher frequency components in the signal to give a clean output eye diagram. The CYV270M0101EQ has DC restoration to compensate the DC content of the SMPTE pathological patterns.

SDI, $\overline{\text{SDI}}$

The CYV270M0101EQ accepts single-ended or differential serial video data streams over 75Ω coaxial cable. It is recommended to AC couple the SDI and $\overline{\text{SDI}}$ inputs as they are internally biased to 1.2V.

SDO, $\overline{\text{SDO}}$

The CYV270M0101EQ has differential serial output interface drivers that use current mode logic [CML] drivers to provide source matching for the transmission line. These outputs are either AC coupled or DC coupled to the HOTLink II SerDes device.

CLI

Cable Length Indicator (CLI) is an analog output that gives an output voltage proportional to the equalized cable length. CLI gives an approximation of the length of cable at the differential serial inputs (SDI, $\overline{\text{SDI}}$). CLI works at standard definition (SD) data rates. The graph in [Figure 3](#) on page 7 illustrates the CLI output voltage at various Belden 1694A cable lengths. With an increase in cable length, CLI output voltage decreases.

MCLADJ

Maximum Cable Length Adjust (MCLADJ) sets the approximate maximum amount of cable to be equalized.

If the MCLADJ voltage is greater than the CLI output voltage, $\overline{\text{CD}}$ is driven high and the equalizer serial differential outputs (SDO, $\overline{\text{SDO}}$) are muted. If the MCLADJ voltage is less than CLI voltage, then the equalizer's differential serial outputs (SDO, $\overline{\text{SDO}}$) are not muted and the incoming data stream is equalized. The graph in [Figure 2](#) on page 7 illustrates the voltage required at MCLADJ input to equalize various Belden 1694A cable lengths for SD data rates. If MCLADJ functionality is not required, this pin should be left floating or tied to ground to allow maximum equalized cable length.

$\overline{\text{CD}}$ /MUTE

Carrier Detect/MUTE ($\overline{\text{CD}}$ /MUTE) is a bidirectional pin that provides an indication of the signal present at the equalizer's input, or it controls the muting of the equalizer's output.

If $\overline{\text{CD}}$ /MUTE is used as an output and the incoming data stream is not present or the cable length exceeds that set by MCLADJ, the voltage at the $\overline{\text{CD}}$ /MUTE output is greater than 2.8V. If $\overline{\text{CD}}$ /MUTE is used as an output, the incoming data stream is present and the cable length does not exceed that set by MCLADJ, then the voltage at the $\overline{\text{CD}}$ /MUTE output is less than 0.8V.

If $\overline{\text{CD}}$ /MUTE is used as an input, and set LOW, the equalizer serial outputs are not muted. If the $\overline{\text{CD}}$ /MUTE is used as an input and is set HIGH, then the equalizer serial outputs are muted.

When an invalid signal or a signal transmitted with a launch amplitude of less than 500 mV at SD data rates is received, the equalizer's serial outputs are muted and the MCLADJ setting is overwritten.

BYPASS

The CYV270M0101EQ has a bypass mode that allows the user to bypass the equalizer's equalization and DC restoration functions. When the Bypass mode is tied to V_{CC} , the signal presented at the equalizer's differential serial inputs (SDI, $\overline{\text{SDI}}$) is routed to the equalizer's differential serial outputs (SDO, $\overline{\text{SDO}}$) without performing equalization.

When BYPASS is tied to GND, the incoming video data stream is equalized and presented at the equalizer's differential serial outputs (SDO, $\overline{\text{SDO}}$).

In equalizer bypass mode, $\overline{\text{CD}}$ /MUTE is not functional.

AGC

Place a capacitor of 1 μF between the AGC \pm pins of the CYV270M0101EQ equalizer.

Maximum Ratings

Exceeding maximum ratings may shorten the useful life of the device. These user guidelines are not tested.

- Storage Temperature -65°C to +150°C
- Ambient Temperature with Power Applied -55°C to +125°C
- Supply Voltage to Ground Potential.....-0.5V to +3.8V
- DC Voltage Applied to Outputs in High Z State -0.5V to $V_{CC} + 0.5V$
- DC Input Voltage -0.5V to $V_{CC}+0.5V$
- Electro Static Discharge (ESD) HBM..... > 2000 V (JEDEC EIA/JESD-A114A)
- Latch Up Current > 200 mA

Power Up Requirements

The CYV270M0101EQ contains one power supply. The voltage on any input or IO pin must not exceed the power pin during power up.

Operating Range

| Range | Ambient Temperature | V_{CC} |
|------------|---------------------|-----------|
| Commercial | 0°C to +70°C | +3.3V ±5% |

DC Electrical Characteristics

| Parameter | Description | Test Conditions | Min | Typ | Max | Unit |
|------------------------------|---|---------------------|-------|-----------------------------------|-------|------|
| V_{CC} | Supply Voltage ^[1] | – | 3.135 | 3.3 | 3.465 | V |
| P_D | Power Consumption ^[2] | – | 125 | 160 | 190 | mW |
| I_S | Supply Current ^[1] | – | 38 | 48 | 60 | mA |
| V_{CMOUT} | Output Common Mode Voltage ^[1] | Load = 50Ω | – | $V_{CC} - \Delta V_{SDO}/2 = 2.9$ | – | V |
| V_{CMIN} | Input Common Mode Voltage ^[1] (Bypass = High) | – | 1 | | 1.4 | V |
| | Input Common Mode Voltage ^[1] (Bypass = Low) | – | 0 | | 2.9 | V |
| – | CLI DC Voltage (0m) ^[1] | – | 2.2 | 2.65 | 2.95 | V |
| – | CLI DC Voltage (No Signal) ^[1] | – | 1.5 | 1.9 | 2.3 | V |
| – | Floating MCLADJ DC Voltage ^[1] | – | | 1.3 | | V |
| – | MCLADJ Range ^[3] | – | 0.4 | 0.72 | 1.02 | V |
| $V_{\overline{CD}/MUTE(OH)}$ | $\overline{CD}/MUTE$ Output Voltage ^[1] | Carrier Not Present | 2.8 | – | – | V |
| $V_{\overline{CD}/MUTE(OL)}$ | | Carrier Present | – | – | 0.8 | V |
| $V_{\overline{CD}/MUTE}$ | $\overline{CD}/MUTE$ Input Voltage Required to Force Outputs to Mute ^[1] | Min to Mute | 2.5 | – | – | V |
| $V_{\overline{CD}/MUTE}$ | $\overline{CD}/MUTE$ Input Voltage Required to Force Active ^[1] | Max to Activate | – | – | 1 | V |

Notes

1. Production test.
2. Calculated results from production test.
3. Not tested. Based on characterization.

AC Electrical Characteristics

| Parameter | Description | Test Conditions | Min | Typ | Max | Unit |
|-------------------|--|--|--------------------|--------------------|------|------|
| – | Serial Input Data Rate ^[1] | – | 143 | – | 360 | Mbps |
| V _{SDI} | Input Voltage Swing | Single-ended, at the transmitter, SD data rate | 500 ^[5] | – | 1200 | mV |
| ΔV _{SDO} | Output Voltage Swing ^[1] | Differential _{p-p} , 50Ω load | 450 | 700 | 950 | mV |
| – | Output Jitter for Various Cable Lengths and Data Rates | 270 Mbps Belden 1694A: 0-350m Canare L-5CFB: 0-350m 800 mV transmit amplitude Equalizer pathological pattern | – | 0.2 ^[1] | – | UI |
| – | Output Rise/Fall Time ^[3, 4] | 20% - 80% | 80 | 120 | 350 | ps |
| – | Mismatch in Rise/Fall Time ^[3, 4] | – | – | – | 30 | ps |
| – | Duty Cycle Distortion ^[3, 4] | SD Color Bar Pattern | – | 0.03 | – | UI |
| – | Overshoot ^[3, 4] | – | – | – | 10 | % |
| – | Input Return Loss ^[3, 4] | – | -15 | – | – | dB |
| – | Input Resistance ^[3] | Single-ended | – | 2.5 | – | kΩ |
| – | Input Capacitance ^[3] | Single-ended | – | 1 | – | pF |
| – | Output Resistance ^[3] | Single-ended | – | 50 | – | Ω |

Notes

4. Not tested. Guaranteed by design simulations.
5. Based on characterization across temperature and voltage with 350m of Belden 1694A cable, transmitting SMPTE Equalizer Pathological Test Pattern.

Typical Performance Graphs

(Unless otherwise stated, $V_{CC} = 3.3V$, $T_A = 25^\circ C$)

Figure 2. MCLADJ Input Voltage vs. Belden 1694A Cable Length at SD-SDI Data Rate

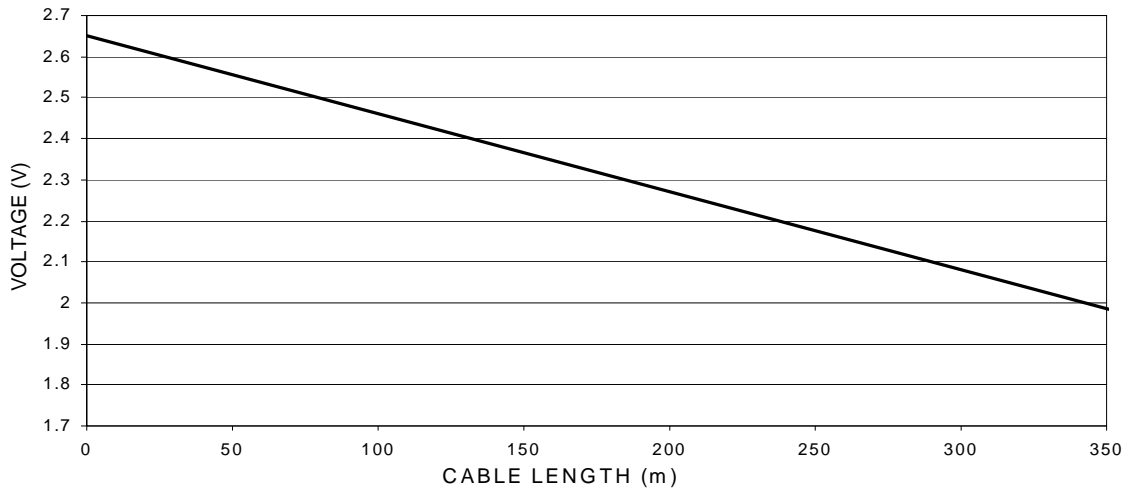
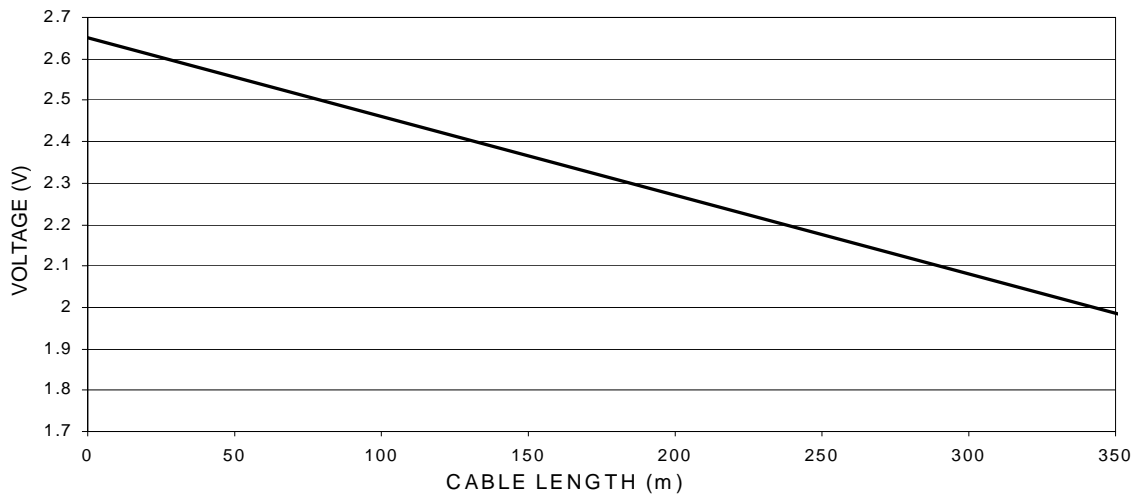
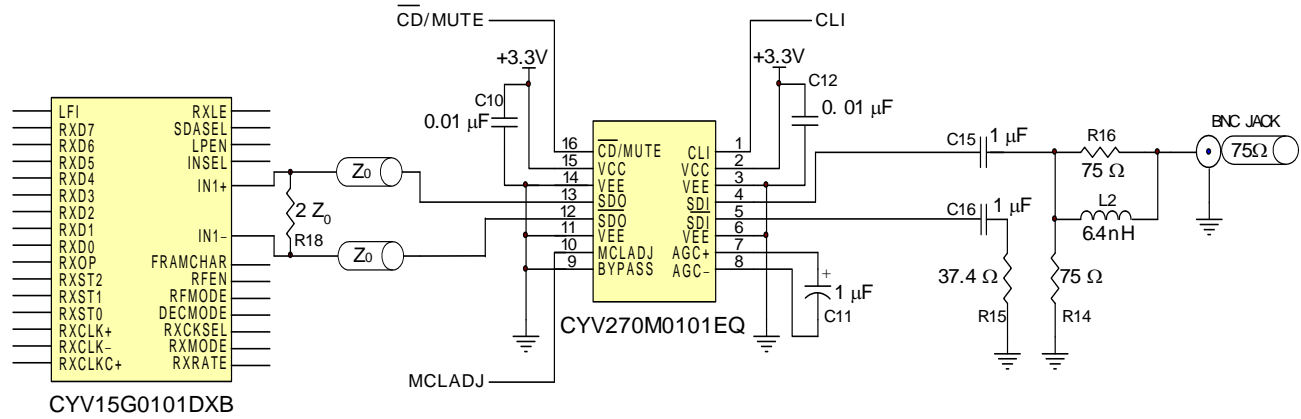

Figure 3. CLI Output Voltage vs. Belden 1694A Cable Length at SD-SDI Data Rate



Typical Application Circuit

Figure 4. Interfacing CYV270M0101EQ to the HOTLink II SerDes



Ordering Information

| Ordering Code | Package Name | Package Type | Operating Range |
|-------------------|--------------|-----------------------------|-----------------|
| CYV270M0101EQ-SXC | SZ16.15 | Pb-Free 16-Pin 150 Mil SOIC | 0 to 70°C |

Package Dimensions

Figure 5. 16-Pin (150 Mil) SOIC S16.15

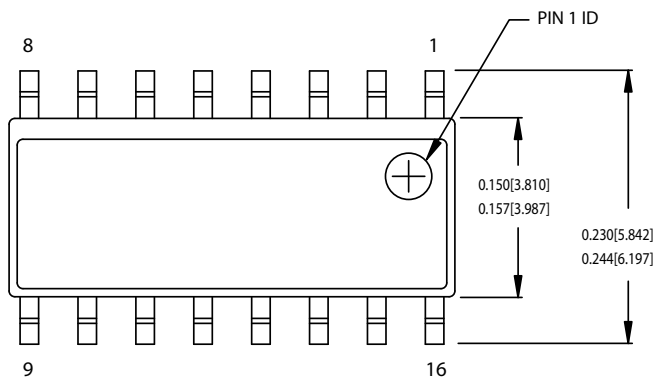

DIMENSIONS IN INCHES[MM] MIN.
MAX.

REFERENCE JEDEC MS-012

PACKAGE WEIGHT 0.15gms

| PART # | |
|---------|----------------|
| S16.15 | STANDARD PKG. |
| SZ16.15 | LEAD FREE PKG. |

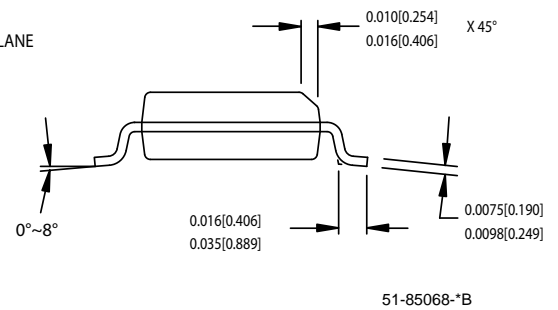
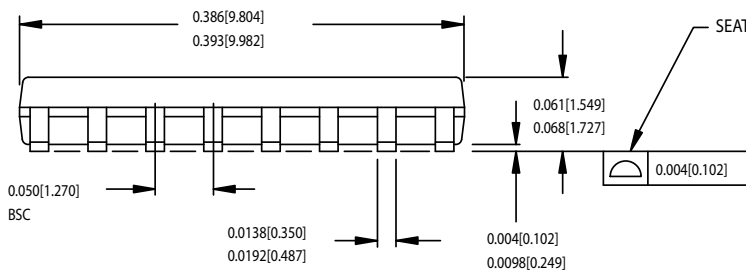

Document History Page

| Document Title: CYV270M0101EQ Adaptive Video Cable Equalizer Document Number: 001-06830 | | | | |
|--|---------|------------|-----------------|--|
| Rev. | Ecn No. | Issue Date | Orig. Of Change | Description Of Change |
| ** | 427547 | SEE ECN | BCD | New preliminary datasheet |
| *A | 663916 | SEE ECN | FRE | Updated AC and DC parameters. Changed datasheet status from preliminary to final |
| *B | 1396423 | SEE ECN | UKK/AESA | Updated AC and DC electrical characteristics and pin description of CD/MUTE and MCLADJ |

© Cypress Semiconductor Corporation, 2007. The information contained herein is subject to change without notice. Cypress Semiconductor Corporation assumes no responsibility for the use of any circuitry other than circuitry embodied in a Cypress product. Nor does it convey or imply any license under patent or other rights. Cypress products are not warranted nor intended to be used for medical, life support, life saving, critical control or safety applications, unless pursuant to an express written agreement with Cypress. Furthermore, Cypress does not authorize its products for use as critical components in life-support systems where a malfunction or failure may reasonably be expected to result in significant injury to the user. The inclusion of Cypress products in life-support systems application implies that the manufacturer assumes all risk of such use and in doing so indemnifies Cypress against all charges.

Any Source Code (software and/or firmware) is owned by Cypress Semiconductor Corporation (Cypress) and is protected by and subject to worldwide patent protection (United States and foreign), United States copyright laws and international treaty provisions. Cypress hereby grants to licensee a personal, non-exclusive, non-transferable license to copy, use, modify, create derivative works of, and compile the Cypress Source Code and derivative works for the sole purpose of creating custom software and or firmware in support of licensee product to be used only in conjunction with a Cypress integrated circuit as specified in the applicable agreement. Any reproduction, modification, translation, compilation, or representation of this Source Code except as specified above is prohibited without the express written permission of Cypress.

Disclaimer: CYPRESS MAKES NO WARRANTY OF ANY KIND, EXPRESS OR IMPLIED, WITH REGARD TO THIS MATERIAL, INCLUDING, BUT NOT LIMITED TO, THE IMPLIED WARRANTIES OF MERCHANTABILITY AND FITNESS FOR A PARTICULAR PURPOSE. Cypress reserves the right to make changes without further notice to the materials described herein. Cypress does not assume any liability arising out of the application or use of any product or circuit described herein. Cypress does not authorize its products for use as critical components in life-support systems where a malfunction or failure may reasonably be expected to result in significant injury to the user. The inclusion of Cypress' product in a life-support systems application implies that the manufacturer assumes all risk of such use and in doing so indemnifies Cypress against all charges.

Use may be limited by and subject to the applicable Cypress software license agreement.

Looking for pricing, stock, or lifecycle information?

Click below to explore more details on WIN SOURCE:

 [View CYV270M0101EQ-SXC on WIN SOURCE](#)

 [Cypress Semiconductor Corp](#) Information

Optimize Your Supply Chain with WIN SOURCE Solutions

-  Global Sourcing Solution
-  Obsolete Management
-  Cost Control Management
-  Shortage Management
-  Alternative Solution
-  Excess Inventory Management