



THE DATASHEET OF COP8SAC720N8



COP8SAA5,COP8SAA7,COP8SAB5,COP8SAB7, COP8SAC5,COP8SAC7

*COP8SA Family 8-Bit CMOS ROM Based and One-Time Programmable (OTP)
Microcontroller with 1k to 4k Memory, Power On Reset, and Very Small
Packaging*



Literature Number: SNOS878E

COP8SA Family

8-Bit CMOS ROM Based and One-Time Programmable (OTP) Microcontroller with 1k to 4k Memory, Power On Reset, and Very Small Packaging

General Description

Note: COP8SAx devices are instruction set and pin compatible supersets of the COP800 Family devices, and are replacements for these in new designs when possible.

The COP8SAx Rom based and OTP microcontrollers are highly integrated COP8™ feature core devices, with 1k to 4k memory and advanced features including low EMI. These single-chip CMOS devices are suited for low cost applications requiring a full featured controller, low EMI, and POR. 100% form-fit-function compatible OTP versions are available with 1k, 2k, and 4k memory, and in a variety of packages including 28-pin CSP. Erasable windowed versions are available for use with a range of COP8 software and hardware development tools.

Family features include an 8-bit memory mapped architecture, 10 MHz CKI with 1 μ s instruction cycle, one multi-function 16-bit timer/counter with PWM output, MICROWIRE/PLUS™ serial I/O, two power saving HALT/IDLE modes, MIWU, idle timer, on-chip R/C oscillator, 12 high current outputs, user selectable options (WATCHDOG™, 4 clock/oscillator modes, power-on-reset), low EMI 2.7V to 5.5V operation, and 16/20/28/40/44 pin packages.

Devices included in this datasheet are:

Device	Memory (bytes)	RAM (bytes)	I/O Pins	Packages	Temperature
COP8SAA5	1k ROM	64	12/16/24	16/20/28 DIP/SOIC, 28 CSP	0 to +70°C, -40 to +85°C, -40 to +125°C
COP8SAB5	2k ROM	128	16/24	20/28 DIP/SOIC, 28 CSP	0 to +70°C, -40 to +85°C, -40 to +125°C
COP8SAC5	4k ROM	128	16/24/36/40	20/28 DIP/SOIC, 28 CSP, 40 DIP, 44 PLCC/QFP	0 to +70°C, -40 to +85°C, -40 to +125°C
COP8SAA7	1k OTP EPROM	64	12/16/24	16/20/28 DIP/SOIC, 28 CSP	0 to +70°C, -40 to +85°C, -40 to +125°C
COP8SAB7	2k OTP EPROM	128	16/24	20/28 DIP/SOIC, 28 CSP	0 to +70°C, -40 to +85°C, -40 to +125°C
COP8SAC7	4k OTP EPROM	128	16/24	20/28 DIP/SOIC, 28 CSP, 40 DIP, 44 PLCC/QFP	0 to +70°C, -40 to +85°C, -40 to +125°C
COP8SAC7-Q3	4k EPROM	128	16/24/36	20/28/40 DIP	Room Temp. Only
COP8SAC7-J3	4k EPROM	128	40	44 PLCC	Room Temp. Only

Key Features

- Low cost 8-bit OTP microcontroller
- OTP program space with read/write protection (fully secured)
- Quiet Design (low radiated emissions)
- Multi-Input Wakeup pins with optional interrupts (4 to 8 pins)
- 8 bytes of user storage space in EPROM
- User selectable clock options
 - Crystal/Resonator options
 - Crystal/Resonator option with on-chip bias resistor
 - External oscillator
 - Internal R/C oscillator
- Internal Power-On Reset—user selectable
- WATCHDOG and Clock Monitor Logic—user selectable
- Up to 12 high current outputs

TRI-STATE® is a registered trademark of National Semiconductor Corporation.
 MICROWIRE/PLUS™, COP8™, MICROWIRE™ and WATCHDOG™ are trademarks of National Semiconductor Corporation.
 iceMASTER® is a registered trademark of MetaLink Corporation.

COP8SA Family, 8-Bit CMOS ROM Based and One-Time Programmable (OTP) Microcontroller with 1k to 4k Memory, Power On Reset, and Very Small Packaging

CPU Features

- Versatile easy to use instruction set
- 1 μ s instruction cycle time
- Eight multi-source vectored interrupts servicing
 - External interrupt
 - Idle Timer T0
 - One Timer (with 2 interrupts)
 - MICROWIRE/PLUS Serial Interface
 - Multi-Input Wake Up
 - Software Trap
 - Default VIS (default interrupt)
- 8-bit Stack Pointer SP (stack in RAM)
- Two 8-bit Register Indirect Data Memory Pointers
- True bit manipulation
- Memory mapped I/O
- BCD arithmetic instructions

Peripheral Features

- Multi-Input Wakeup Logic
- One 16-bit timer with two 16-bit registers supporting:
 - Processor Independent PWM mode
 - External Event counter mode
 - Input Capture mode
- Idle Timer
- MICROWIRE/PLUS Serial Interface (SPI Compatible)

I/O Features

- Software selectable I/O options
 - TRI-STATE[®] Output
 - Push-Pull Output
 - Weak Pull Up Input
 - High Impedance Input
- Schmitt trigger inputs on ports G and L
- Up to 12 high current outputs
- Pin efficient (i.e., 40 pins in 44-pin package are devoted to useful I/O)

Fully Static CMOS Design

- Low current drain (typically < 4 μ A)
- Single supply operation: 2.7V to 5.5V
- Two power saving modes: HALT and IDLE

Temperature Ranges

0°C to +70°C, -40°C to +85°C, and -40°C to +125°C

Development Support

- Windowed packages for DIP and PLCC
- Real time emulation and full program debug offered by MetaLink Development System

Block Diagram

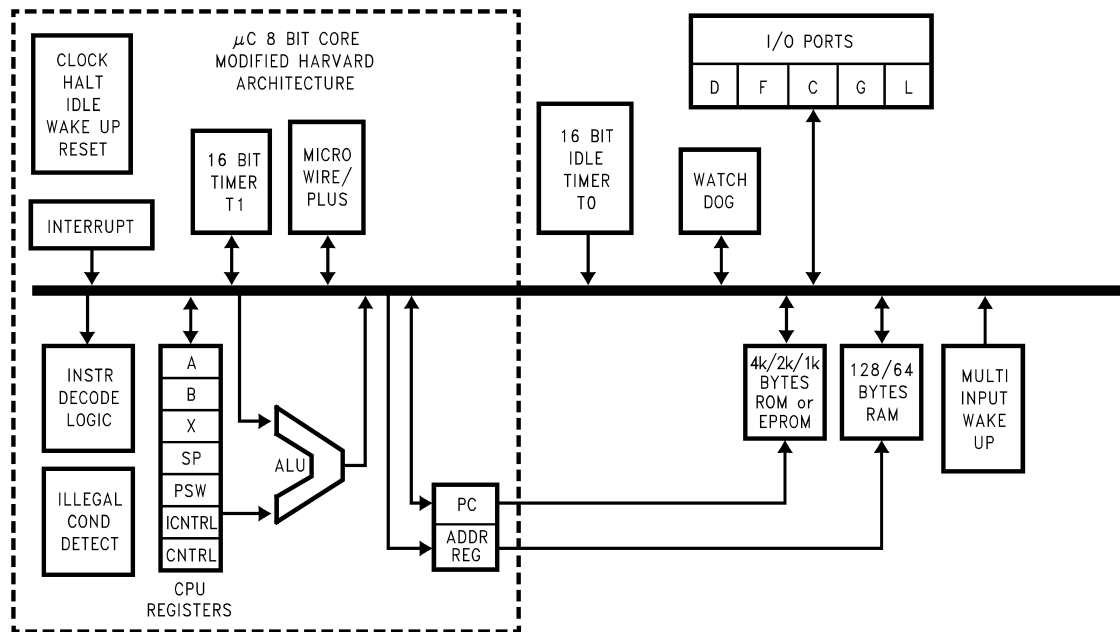

FIGURE 1. COP8SAx Block Diagram

DS012838-1

General Description (Continued)

Key features include an 8-bit memory mapped architecture, a 16-bit timer/counter with two associated 16-bit registers supporting three modes (Processor Independent PWM generation, External Event counter, and Input Capture capabilities), two power saving HALT/IDLE modes with a multi-sourced wakeup/interrupt capability, on-chip R/C oscillator, high current outputs, user selectable options such as WATCHDOG, Oscillator configuration, and power-on-reset.

1.1 EMI REDUCTION

The COP8SAx family of devices incorporates circuitry that guards against electromagnetic interference—an increasing problem in today's microcontroller board designs. National's patented EMI reduction technology offers low EMI clock circuitry, gradual turn-on output drivers (GTOs) and internal I_{CC} smoothing filters, to help circumvent many of the EMI issues influencing embedded control designs. National has achieved 15 dB–20 dB reduction in EMI transmissions when designs have incorporated its patented EMI reducing circuitry.

1.2 ARCHITECTURE

The COP8SAx family is based on a modified Harvard architecture, which allows data tables to be accessed directly from program memory. This is very important with modern microcontroller-based applications, since program memory is usually ROM or EPROM, while data memory is usually RAM. Consequently data tables usually need to be contained in ROM or EPROM, so they are not lost when the microcontroller is powered down. In a modified Harvard architecture, instruction fetch and memory data transfers can be overlapped with a two stage pipeline, which allows the next instruction to be fetched from program memory while the current instruction is being executed using data memory. This is not possible with a Von Neumann single-address bus architecture.

The COP8SAx family supports a software stack scheme that allows the user to incorporate many subroutine calls. This capability is important when using High Level Languages. With a hardware stack, the user is limited to a small fixed number of stack levels.

1.3 INSTRUCTION SET

In today's 8-bit microcontroller application arena cost/performance, flexibility and time to market are several of the key issues that system designers face in attempting to build well-engineered products that compete in the marketplace. Many of these issues can be addressed through the manner in which a microcontroller's instruction set handles processing tasks. And that's why COP8 family offers a unique and code-efficient instruction set—one that provides the flexibility, functionality, reduced costs and faster time to market that today's microcontroller based products require.

Code efficiency is important because it enables designers to pack more on-chip functionality into less program memory space (ROM/OTP). Selecting a microcontroller with less program memory size translates into lower system costs, and the added security of knowing that more code can be packed into the available program memory space.

1.3.1 Key Instruction Set Features

The COP8SAx family incorporates a unique combination of instruction set features, which provide designers with optimum code efficiency and program memory utilization.

Single Byte/Single Cycle Code Execution

The efficiency is due to the fact that the majority of instructions are of the single byte variety, resulting in minimum program space. Because compact code does not occupy a substantial amount of program memory space, designers can integrate additional features and functionality into the microcontroller program memory space. Also, the majority instructions executed by the device are single cycle, resulting in minimum program execution time. In fact, 77% of the instructions are single byte single cycle, providing greater code and I/O efficiency, and faster code execution.

1.3.2 Many Single-Byte, Multifunction Instructions

The COP8SAx instruction set utilizes many single-byte, multifunction instructions. This enables a single instruction to accomplish multiple functions, such as DRSZ, DCOR, JID, and LOAD/EXCHANGE instructions with post-incrementing and post-decrementing, to name just a few examples. In many cases, the instruction set can simultaneously execute as many as three functions with the same single-byte instruction.

JID: (Jump Indirect); Single byte instruction; decodes external events and jumps to corresponding service routines (analogous to "DO CASE" statements in higher level languages).

LAID: (Load Accumulator-Indirect); Single byte look up table instruction provides efficient data path from the program memory to the CPU. This instruction can be used for table lookup and to read the entire program memory for checksum calculations.

RETSK: (Return Skip); Single byte instruction allows return from subroutine and skips next instruction. Decision to branch can be made in the subroutine itself, saving code.

AUTOINC/DEC: (Auto-Increment/Auto-Decrement); These instructions use the two memory pointers B and X to efficiently process a block of data (analogous to "FOR NEXT" in higher level languages).

1.3.3 Bit-Level Control

Bit-level control over many of the microcontroller's I/O ports provides a flexible means to ease layout concerns and save board space. All members of the COP8 family provide the ability to set, reset and test any individual bit in the data memory address space, including memory-mapped I/O ports and associated registers. Three memory-mapped pointers handle register indirect addressing and software stack pointer functions. The memory data pointers allow the option of post-incrementing or post-decrementing with the data movement instructions (LOAD/EXCHANGE). And 15 memory-mapped registers allow designers to optimize the precise implementation of certain specific instructions.

1.4 PACKAGING/PIN EFFICIENCY

Real estate and board configuration considerations demand maximum space and pin efficiency, particularly given today's high integration and small product form factors. Microcontroller users try to avoid using large packages to get the I/O needed. Large packages take valuable board space and increases device cost, two trade-offs that microcontroller designs can ill afford.

The COP8 family offers a wide range of packages and do not waste pins: up to 90.9% (or 40 pins in the 44-pin package) are devoted to useful I/O.

Connection Diagrams

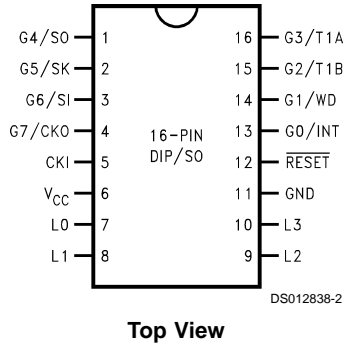

Top View

DS012838-2

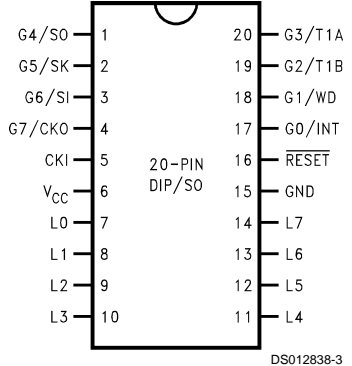

Top View

DS012838-3

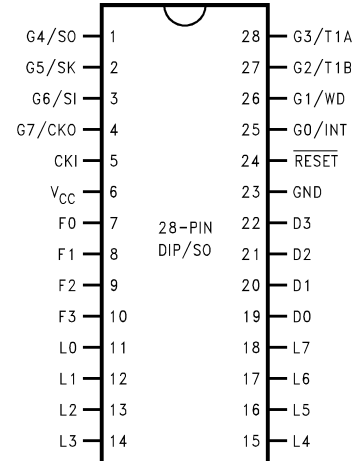

Top View

DS012838-4

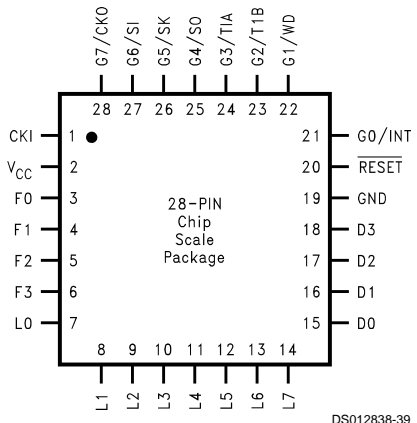

Top View

DS012838-39

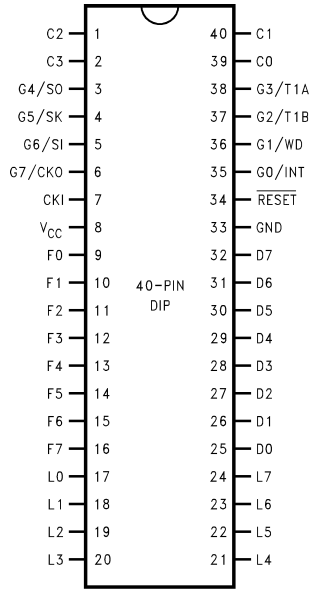

Top View

DS012838-5

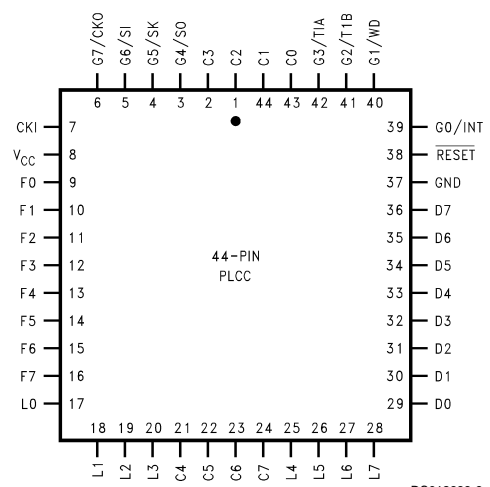

Top View

DS012838-6

FIGURE 2. Connection Diagrams

Ordering Information

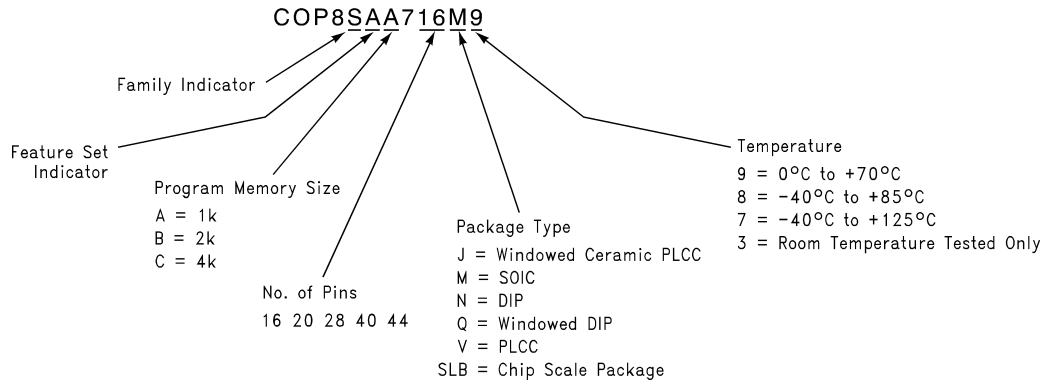

DS012838-8

FIGURE 3. Part Numbering Scheme

Temperature	1k EPROM		2k EPROM		4k EPROM		4k EPROM	
	Order Number	Package	Order Number	Package	Order Number	Package	Windowed Device Order Number	Package
0°C to +70°C	COP8SAA716M9	16M						
	COP8SAA720M9	20M	COP8SAB720M9	20M	COP8SAC720M9	20M		
	COP8SAA728M9	28M	COP8SAB728M9	28M	COP8SAC728M9	28M		
	COP8SAA716N9	16N						
	COP8SAA720N9	20N	COP8SAB720N9	20N	COP8SAC720N9	20N	COP8SAC720Q3	20Q
	COP8SAA728N9	28N	COP8SAB728N9	28N	COP8SAC728N9	28N	COP8SAC728Q3	28Q
					COP8SAC740N9	40N	COP8SAC740Q3	40Q
-40°C to +85°C					COP8SAC744V9	44V	COP8SAC744J3	44J
	COP8SAA716M8	16M						
	COP8SAA720M8	20M	COP8SAB720M8	20M	COP8SAC720M8	20M		
	COP8SAA728M8	28M	COP8SAB728M8	28M	COP8SAC728M8	28M		
	COP8SAA716N8	16N						
	COP8SAA720N8	20N	COP8SAB720N8	20N	COP8SAC720N8	20N		
	COP8SAA728N8	28N	COP8SAB728N8	28N	COP8SAC728N8	28N		
					COP8SAC740N8	40N		
				COP8SAC744V8	44V			
-40°C to +125°C	COP8SAA7SLB8	SLB	COP8SAB7SLB8	SLB	COP8SAC7SLB8	SLB		
					COP8SAC720M7	20M		
					COP8SAC728M7	28M		
					COP8SAC720N7	20N		
					COP8SAC728N7	28N		
					COP8SAC740N7	40N		
				COP8SAC744V7	44V			

Ordering Information (Continued)**4.0 Electrical Characteristics****Absolute Maximum Ratings** (Note 1)

If Military/Aerospace specified devices are required, please contact the National Semiconductor Sales Office/Distributors for availability and specifications.

Supply Voltage (V_{CC})

7V

Voltage at Any Pin

-0.6V to $V_{CC} + 0.6V$

ESD Protection Level

2 kV

(Human Body Model)

Total Current into V_{CC} Pin (Source)

80 mA

Total Current out of GND Pin (Sink)

100 mA

Storage Temperature Range

-65°C to +140°C

Note 1: Absolute maximum ratings indicate limits beyond which damage to the device may occur. DC and AC electrical specifications are not ensured when operating the device at absolute maximum ratings.

DC Electrical Characteristics

0°C ≤ T_A ≤ +70°C unless otherwise specified.

Parameter	Conditions	Min	Typ	Max	Units
Operating Voltage	(Note 8)	2.7		5.5	V
Power Supply Rise Time from 0.0V (On-Chip Power-On Reset Selected)		10 ns		50 ms	
V_{CC} Start Voltage to Guarantee POR				0.25	V
Power Supply Ripple (Note 3)	Peak-to-Peak			0.1 V_{CC}	V
Supply Current (Note 4)					
CKI = 10 MHz	$V_{CC} = 5.5V, t_C = 1 \mu s$			6	mA
CKI = 4 MHz	$V_{CC} = 4.5V, t_C = 2.5 \mu s$			2.1	mA
HALT Current (Note 5) —WATCHDOG Disabled	$V_{CC} = 5.5V, CKI = 0 \text{ MHz}$		<4	8	μA
IDLE Current (Note 4)					
CKI = 10 MHz	$V_{CC} = 5.5V, t_C = 1 \mu s$			1.5	mA
CKI = 4 MHz	$V_{CC} = 4.5V, t_C = 2.5 \mu s$			0.8	mA
Input Levels (V_{IH}, V_{IL})					
RESET					
Logic High		0.8 V_{CC}			V
Logic Low				0.2 V_{CC}	V
CKI, All Other Inputs					
Logic High		0.7 V_{CC}			V
Logic Low				0.2 V_{CC}	V
Value of the Internal Bias Resistor for the Crystal/Resonator Oscillator		0.5	1.0	2.0	$M\Omega$
CKI Resistance to V_{CC} or GND when R/C Oscillator is Selected	$V_{CC} = 5.5V$	5	8	11	k Ω
Hi-Z Input Leakage (same as TRI-STATE output)	$V_{CC} = 5.5V$	-2		+2	μA
Input Pullup Current	$V_{CC} = 5.5V, V_{IN} = 0V$	-40		-250	μA
G and L Port Input Hysteresis			0.25 V_{CC}		V

DC Electrical Characteristics (Continued)0°C ≤ T_A ≤ +70°C unless otherwise specified.

Parameter	Conditions	Min	Typ	Max	Units
Output Current Levels					
D Outputs					
Source	V _{CC} = 4.5V, V _{OH} = 3.3V	-0.4			mA
	V _{CC} = 2.7V, V _{OH} = 1.8V	-0.2			mA
Sink	V _{CC} = 4.5V, V _{OL} = 1.0V	10			mA
	V _{CC} = 2.7V, V _{OL} = 0.4V	2			mA
L Port					
Source (Weak Pull-Up)	V _{CC} = 4.5V, V _{OH} = 2.7V	-10		-110	μA
	V _{CC} = 2.7V, V _{OH} = 1.8V	-2.5		-33	μA
Source (Push-Pull Mode)	V _{CC} = 4.5V, V _{OH} = 3.3V	-0.4			mA
	V _{CC} = 2.7V, V _{OH} = 1.8V	-0.2			mA
Sink (L0–L3, Push-Pull Mode)	V _{CC} = 4.5V, V _{OL} = 1.0V	10			mA
	V _{CC} = 2.7V, V _{OL} = 0.4V	2			mA
Sink (L4–L7, Push-Pull Mode)	V _{CC} = 4.5V, V _{OL} = 0.4V	1.6			mA
	V _{CC} = 2.7V, V _{OL} = 0.4V	0.7			mA
All Others					
Source (Weak Pull-Up Mode)	V _{CC} = 4.5V, V _{OH} = 2.7V	-10		-110	μA
	V _{CC} = 2.7V, V _{OH} = 1.8V	-2.5		-33	μA
Source (Push-Pull Mode)	V _{CC} = 4.5V, V _{OH} = 3.3V	-0.4			mA
	V _{CC} = 2.7V, V _{OH} = 1.8V	-0.2			mA
Sink (Push-Pull Mode)	V _{CC} = 4.5V, V _{OL} = 0.4V	1.6			mA
	V _{CC} = 2.7V, V _{OL} = 0.4V	0.7			mA
Allowable Sink Current per Pin (Note 8)					
D Outputs and L0 to L3				15	mA
All Others				3	mA
Maximum Input Current without Latchup (Note 6)					
				±200	mA
RAM Retention Voltage, V _r					
V _{CC} Rise Time from a V _{CC} ≥ 2.0V	(Note 9)	2.0			V
		12			μs
Input Capacitance	(Note 8)			7	pF
Load Capacitance on D2	(Note 8)			1000	pF

AC Electrical Characteristics

0°C ≤ T_A ≤ +70°C unless otherwise specified.

Parameter	Conditions	Min	Typ	Max	Units
Instruction Cycle Time (t _C)					
Crystal/Resonator, External	4.5V ≤ V _{CC} ≤ 5.5V	1.0		DC	μs
	2.7V ≤ V _{CC} < 4.5V	2.0		DC	μs
Internal R/C Oscillator	4.5V ≤ V _{CC} ≤ 5.5V		1.667		μs
	2.7V ≤ V _{CC} < 4.5V		TBD		μs
R/C Oscillator Frequency Variation (Note 8)	4.5V ≤ V _{CC} ≤ 5.5V			±35	%
	2.7V ≤ V _{CC} < 4.5V			TBD	%
External CKI Clock Duty Cycle (Note 8)	fr = Max	45		55	%
Rise Time (Note 8)	fr = 10 MHz Ext Clock			12	ns
Fall Time (Note 8)	fr = 10 MHz Ext Clock			8	ns
Inputs					
t _{SETUP}	4.5V ≤ V _{CC} ≤ 5.5V	200			ns
	2.7V ≤ V _{CC} < 4.5V	500			ns
t _{HOLD}	4.5V ≤ V _{CC} ≤ 5.5V	60			ns
	2.7V ≤ V _{CC} < 4.5V	150			ns
Output Propagation Delay (Note 7)	R _L = 2.2k, C _L = 100 pF				
t _{PD1} , t _{PD0}					
SO, SK	4.5V ≤ V _{CC} ≤ 5.5V			0.7	μs
	2.7V ≤ V _{CC} < 4.5V			1.75	μs
All Others	4.5V ≤ V _{CC} ≤ 5.5V			1.0	μs
	2.7V ≤ V _{CC} < 4.5V			2.5	μs
MICROWIRE Setup Time (t _{UWS}) (Note 7)		20			ns
MICROWIRE Hold Time (t _{UWH}) (Note 7)		56			ns
MICROWIRE Output Propagation Delay (t _{UPD})				220	ns
MICROWIRE Maximum Shift Clock					
Master Mode				500	kHz
Slave Mode				1	MHz
Input Pulse Width (Note 7)					
Interrupt Input High Time		1			t _C
Interrupt Input Low Time		1			t _C
Timer 1 Input High Time		1			t _C
Timer 1 Input Low Time		1			t _C
Reset Pulse Width		1			μs

Note 2: t_C = Instruction cycle time (Clock input frequency divided by 10).

Note 3: Maximum rate of voltage change must be < 0.5 V/ms.

Note 4: Supply and IDLE currents are measured with CKI driven with a square wave Oscillator, CKO driven 180° out of phase with CKI, inputs connected to V_{CC} and outputs driven low but not connected to a load.

Note 5: The HALT mode will stop CKI from oscillating in the R/C and the Crystal configurations. In the R/C configuration, CKI is forced high internally. In the crystal or external configuration, CKI is TRI-STATE. Measurement of I_{DD} HALT is done with device neither sourcing nor sinking current; with L, F, C, G0, and G2–G5 programmed as low outputs and not driving a load; all outputs programmed low and not driving a load; all inputs tied to V_{CC}; WATCHDOG and clock monitor disabled. Parameter refers to HALT mode entered via setting bit 7 of the G Port data register.

Note 6: Pins G6 and RESET are designed with a high voltage input network. These pins allow input voltages > V_{CC} and the pins will have sink current to V_{CC} when biased at voltages > V_{CC} (the pins do not have source current when biased at a voltage below V_{CC}). The effective resistance to V_{CC} is 750Ω (typical). These two pins will not latch up. The voltage at the pins must be limited to < 14V. **WARNING: Voltages in excess of 14V will cause damage to the pins. This warning excludes ESD transients.**

Note 7: The output propagation delay is referenced to the end of the instruction cycle where the output change occurs.

Note 8: Parameter characterized but not tested.

Note 9: Rise times faster than this specification may reset the device if POR is enabled and may affect the value of Idle Timer T0 if POR is not enabled.

Absolute Maximum Ratings (Note 10)

If Military/Aerospace specified devices are required, please contact the National Semiconductor Sales Office/Distributors for availability and specifications.

Supply Voltage (V_{CC})	7V
Voltage at Any Pin	-0.6V to V_{CC} +0.6V
ESD Protection Level	2 kV (Human Body Model)

Total Current into V_{CC} Pin (Source)	80 mA
Total Current out of GND Pin (Sink)	100 mA
Storage Temperature Range	-65°C to +140°C

Note 10: Absolute maximum ratings indicate limits beyond which damage to the device may occur. DC and AC electrical specifications are not ensured when operating the device at absolute maximum ratings.

DC Electrical Characteristics

-40°C ≤ T_A ≤ +85°C unless otherwise specified.

Parameter	Conditions	Min	Typ	Max	Units
Operating Voltage		2.7		5.5	V
Power Supply Rise Time from 0.0V (On-Chip Power-On Reset Selected)	(Note 17)	10 ns		50 ms	
V_{CC} Start Voltage to Guarantee POR				0.25	V
Power Supply Ripple (Note 12)	Peak-to-Peak			0.1 V_{CC}	V
Supply Current (Note 13) CKI = 10 MHz	$V_{CC} = 5.5V$, $t_C = 1 \mu s$			6.0	mA
HALT Current (Note 14) — WATCHDOG Disabled	$V_{CC} = 5.5V$, CKI = 0 MHz		<4	10.0	μA
IDLE Current (Note 13) CKI = 10 MHz	$V_{CC} = 5.5V$, $t_C = 1 \mu s$			1.5	mA
Input Levels (V_{IH} , V_{IL}) \overline{RESET}					
Logic High		0.8 V_{CC}			V
Logic Low				0.2 V_{CC}	V
CKI, All Other Inputs					
Logic High		0.7 V_{CC}			V
Logic Low				0.2 V_{CC}	V
Value of the Internal Bias Resistor for the Crystal/Resonator Oscillator		0.5	1.0	2.0	$M\Omega$
CKI Resistance to V_{CC} or GND when R/C Oscillator is Selected	$V_{CC} = 5.5V$	5	8	11	$k\Omega$
Hi-Z Input Leakage (same as TRI-STATE output)	$V_{CC} = 5.5V$	-2		+2	μA
Input Pullup Current	$V_{CC} = 5.5V$, $V_{IN} = 0V$	-40		-250	μA
G and L Port Input Hysteresis		0.25 V_{CC}			V

DC Electrical Characteristics (Continued)-40°C ≤ T_A ≤ +85°C unless otherwise specified.

Parameter	Conditions	Min	Typ	Max	Units
Output Current Levels					
D Outputs					
Source	V _{CC} = 4.5V, V _{OH} = 3.3V	-0.4			mA
	V _{CC} = 2.7V, V _{OH} = 1.8V	-0.2			mA
Sink	V _{CC} = 4.5V, V _{OL} = 1.0V	10			mA
	V _{CC} = 2.7V, V _{OL} = 0.4V	2			mA
L Port					
Source (Weak Pull-Up)	V _{CC} = 4.5V, V _{OH} = 2.7V	-10.0		-110	μA
	V _{CC} = 2.7V, V _{OH} = 1.8V	-2.5		-33	μA
Source (Push-Pull Mode)	V _{CC} = 4.5V, V _{OH} = 3.3V	-0.4			mA
	V _{CC} = 2.7V, V _{OH} = 1.8V	-0.2			mA
Sink (L0–L3, Push-Pull Mode)	V _{CC} = 4.5V, V _{OL} = 1.0V	10.0			mA
	V _{CC} = 2.7V, V _{OL} = 0.4V	2			mA
Sink (L4–L7, Push-Pull Mode)	V _{CC} = 4.5V, V _{OL} = 0.4V	1.6			mA
	V _{CC} = 2.7V, V _{OL} = 0.4V	0.7			mA
All Others					
Source (Weak Pull-Up Mode)	V _{CC} = 4.5V, V _{OH} = 2.7V	-10.0		-110	μA
	V _{CC} = 2.7V, V _{OH} = 1.8V	-2.5		-33	μA
Source (Push-Pull Mode)	V _{CC} = 4.5V, V _{OH} = 3.3V	-0.4			mA
	V _{CC} = 2.7V, V _{OH} = 1.8V	-0.2			mA
Sink (Push-Pull Mode)	V _{CC} = 4.5V, V _{OL} = 0.4V	1.6			mA
	V _{CC} = 2.7V, V _{OL} = 0.4V	0.7			mA
Allowable Sink Current per Pin (Note 17)					
D Outputs and L0 to L3				15	mA
All Others				3	mA
Maximum Input Current without Latchup (Note 15)					
				±200	mA
RAM Retention Voltage, V _r					
		2.0			V
V _{CC} Rise Time from a V _{CC} ≥ 2.0V					
	(Note 18)	12			μs
Input Capacitance					
	(Note 17)			7	pF
Load Capacitance on D2					
	(Note 17)			1000	pF

AC Electrical Characteristics-40°C ≤ T_A ≤ +85°C unless otherwise specified.

Parameter	Conditions	Min	Typ	Max	Units
Instruction Cycle Time (t _C)					
Crystal/Resonator, External	4.5V ≤ V _{CC} ≤ 5.5V	1.0		DC	μs
	2.7V ≤ V _{CC} < 4.5V	2.0		DC	μs
Internal R/C Oscillator	4.5V ≤ V _{CC} ≤ 5.5V		1.667		μs
	2.7V ≤ V _{CC} < 4.5V		TBD		μs
R/C Oscillator Frequency Variation	4.5V ≤ V _{CC} ≤ 5.5V			±35	%
(Note 17)	2.7V ≤ V _{CC} < 4.5V			TBD	%
External CKI Clock Duty Cycle (Note 17)					
	fr = Max	45		55	%
Rise Time (Note 17)	fr = 10 MHz Ext Clock			12	ns
Fall Time (Note 17)	fr = 10 MHz Ext Clock			8	ns

AC Electrical Characteristics (Continued)

$-40^{\circ}\text{C} \leq T_A \leq +85^{\circ}\text{C}$ unless otherwise specified.

Parameter	Conditions	Min	Typ	Max	Units
Inputs					
t_{SETUP}	$4.5\text{V} \leq V_{\text{CC}} \leq 5.5\text{V}$	200			ns
	$2.7\text{V} \leq V_{\text{CC}} < 4.5\text{V}$	500			ns
t_{HOLD}	$4.5\text{V} \leq V_{\text{CC}} \leq 5.5\text{V}$	60			ns
	$2.7\text{V} \leq V_{\text{CC}} < 4.5\text{V}$	150			ns
Output Propagation Delay (Note 16)	$R_L = 2.2\text{k}, C_L = 100\text{ pF}$				
$t_{\text{PD1}}, t_{\text{PD0}}$ SO, SK	$4.5\text{V} \leq V_{\text{CC}} \leq 5.5\text{V}$			0.7	μs
	$2.7\text{V} \leq V_{\text{CC}} < 4.5\text{V}$			1.75	μs
All Others	$4.5\text{V} \leq V_{\text{CC}} \leq 5.5\text{V}$			1.0	μs
	$2.7\text{V} \leq V_{\text{CC}} < 4.5\text{V}$			2.5	μs
MICROWIRE Setup Time (t_{UWS}) (Note 16)		20			ns
MICROWIRE Hold Time (t_{UWH}) (Note 16)		56			ns
MICROWIRE Output Propagation Delay (t_{UPD})				220	ns
MICROWIRE Maximum Shift Clock					
Master Mode				500	kHz
Slave Mode				1	MHz
Input Pulse Width (Note 17)					
Interrupt Input High Time		1			t_C
Interrupt Input Low Time		1			t_C
Timer 1 Input High Time		1			t_C
Timer 1 Input Low Time		1			t_C
Reset Pulse Width		1			μs

Note 11: t_C = Instruction cycle time (Clock input frequency divided by 10).

Note 12: Maximum rate of voltage change must be $< 0.5\text{ V/ms}$.

Note 13: Supply and IDLE currents are measured with CKI driven with a square wave Oscillator, CKO driven 180° out of phase with CKI, inputs connected to V_{CC} and outputs driven low but not connected to a load.

Note 14: The HALT mode will stop CKI from oscillating in the R/C and the Crystal configurations. In the R/C configuration, CKI is forced high internally. In the crystal or external configuration, CKI is TRI-STATE. Measurement of $I_{\text{DD HALT}}$ is done with device neither sourcing nor sinking current; with L, F, C, G0, and G2–G5 programmed as low outputs and not driving a load; all outputs programmed low and not driving a load; all inputs tied to V_{CC} ; clock monitor disabled. Parameter refers to HALT mode entered via setting bit 7 of the G Port data register.

Note 15: Pins G6 and $\overline{\text{RESET}}$ are designed with a high voltage input network. These pins allow input voltages $> V_{\text{CC}}$ and the pins will have sink current to V_{CC} when biased at voltages $> V_{\text{CC}}$ (the pins do not have source current when biased at a voltage below V_{CC}). The effective resistance to V_{CC} is 750Ω (typical). These two pins will not latch up. The voltage at the pins must be limited to $< 14\text{V}$. WARNING: Voltages in excess of 14V will cause damage to the pins. This warning excludes ESD transients.

Note 16: The output propagation delay is referenced to the end of the instruction cycle where the output change occurs.

Note 17: Parameter characterized but not tested.

Note 18: Rise times faster than this specification may reset the device if POR is enabled and may affect the value of Idle Timer T0 if POR is not enabled.

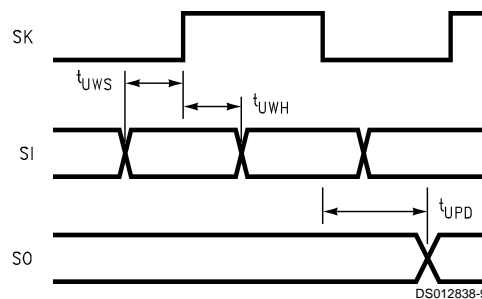

FIGURE 4. MICROWIRE/PLUS Timing

Absolute Maximum Ratings (Note 19)

If Military/Aerospace specified devices are required, please contact the National Semiconductor Sales Office/Distributors for availability and specifications.

Supply Voltage (V_{CC})	7V
Voltage at Any Pin	-0.6V to V_{CC} +0.6V
ESD Protection Level	2 kV (Human Body Model)

Total Current into V_{CC} Pin (Source)	80 mA
Total Current out of GND Pin (Sink)	100 mA
Storage Temperature Range	-65°C to +140°C

Note 19: Absolute maximum ratings indicate limits beyond which damage to the device may occur. DC and AC electrical specifications are not ensured when operating the device at absolute maximum ratings.

DC Electrical Characteristics

-40°C ≤ T_A ≤ +125°C unless otherwise specified.

Parameter	Conditions	Min	Typ	Max	Units
Operating Voltage		4.5		5.5	V
Power Supply Rise Time from 0.0V (On-Chip Power-On Reset Selected)	(Note 17)	10 ns		50 ms	
V_{CC} Start Voltage to Guarantee POR				0.25	V
Power Supply Ripple (Note 12)	Peak-to-Peak			0.1 V_{CC}	V
Supply Current (Note 13) CKI = 10 MHz	$V_{CC} = 5.5V$, $t_C = 1 \mu s$			6.0	mA
HALT Current (Note 14) — WATCHDOG Disabled	$V_{CC} = 5.5V$, CKI = 0 MHz		<10	30	μA
IDLE Current (Note 13) CKI = 10 MHz	$V_{CC} = 5.5V$, $t_C = 1 \mu s$			1.5	mA
Input Levels (V_{IH} , V_{IL}) RESET					
Logic High		0.8 V_{CC}			V
Logic Low				0.2 V_{CC}	V
CKI, All Other Inputs					
Logic High		0.7 V_{CC}			V
Logic Low				0.2 V_{CC}	V
Value of the Internal Bias Resistor for the Crystal/Resonator Oscillator		0.5	1.0	2.0	M Ω
CKI Resistance to V_{CC} or GND when R/C Oscillator is Selected	$V_{CC} = 5.5V$	5	8	11	k Ω
Hi-Z Input Leakage	$V_{CC} = 5.5V$	-5		+5	μA
Input Pullup Current	$V_{CC} = 5.5V$, $V_{IN} = 0V$	-35		-400	μA
G and L Port Input Hysteresis		0.25 V_{CC}			V
Output Current Levels					
D Outputs					
Source	$V_{CC} = 4.5V$, $V_{OH} = 3.3V$	-0.4			mA
Sink	$V_{CC} = 4.5V$, $V_{OL} = 1.0V$	9			mA
L Port					
Source (Weak Pull-Up)	$V_{CC} = 4.5V$, $V_{OH} = 2.7V$	-9		-140	μA
Source (Push-Pull Mode)	$V_{CC} = 4.5V$, $V_{OH} = 3.3V$	-0.4			mA
Sink (L0-L3, Push-Pull Mode)	$V_{CC} = 4.5V$, $V_{OL} = 1.0V$	9			mA
Sink (L4-L7, Push-Pull Mode)	$V_{CC} = 4.5V$, $V_{OL} = 0.4V$	1.4			mA
All Others					
Source (Weak Pull-Up Mode)	$V_{CC} = 4.5V$, $V_{OH} = 2.7V$	-9		-140	μA
Source (Push-Pull Mode)	$V_{CC} = 4.5V$, $V_{OH} = 3.3V$	-0.4			mA
Sink (Push-Pull Mode)	$V_{CC} = 4.5V$, $V_{OL} = 0.4V$	1.4			mA
TRI-STATE Leakage	$V_{CC} = 5.5V$	-5		+5	μA

DC Electrical Characteristics (Continued)-40°C ≤ T_A ≤ +125°C unless otherwise specified.

Parameter	Conditions	Min	Typ	Max	Units
Allowable Sink Current per Pin (Note 17)					
D Outputs and L0 to L3				15	mA
All Others				3	mA
Maximum Input Current without Latchup (Note 15)	Room Temp			±200	mA
RAM Retention Voltage, V _r		2.0			V
V _{CC} Rise Time from a V _{CC} ≥ 2.0V	(Note 18)	12			μs
Input Capacitance	(Note 17)			7	pF
Load Capacitance on D2	(Note 17)			1000	pF

AC Electrical Characteristics-40°C ≤ T_A ≤ +125°C unless otherwise specified.

Parameter	Conditions	Min	Typ	Max	Units
Instruction Cycle Time (t _C)					
Crystal/Resonator, External	4.5V ≤ V _{CC} ≤ 5.5V	1.0		DC	μs
Internal R/C Oscillator	4.5V ≤ V _{CC} ≤ 5.5V		1.667	DC	μs
R/C Oscillator Frequency Variation (Note 6)	4.5V ≤ V _{CC} ≤ 5.5V			TBD	%
External CKI Clock Duty Cycle (Note 6)	fr = Max	45		55	%
Rise Time (Note 6)	fr = 10 MHz Ext Clock			12	ns
Fall Time (Note 6)	fr = 10 MHz Ext Clock			8	ns
Inputs					
t _{SETUP}	4.5V ≤ V _{CC} ≤ 5.5V	200			ns
t _{HOLD}	4.5V ≤ V _{CC} ≤ 5.5V	60			ns
Output Propagation Delay (Note 5)	R _L = 2.2k, C _L = 100 pF				
t _{PD1} , t _{PD0}	4.5V ≤ V _{CC} ≤ 5.5V			0.7	μs
SO, SK	4.5V ≤ V _{CC} ≤ 5.5V			1.0	μs
All Others	4.5V ≤ V _{CC} ≤ 5.5V				
MICROWIRE Setup Time (t _{UWS}) (Note 5)		20			ns
MICROWIRE Hold Time (t _{UWH}) (Note 5)		56			ns
MICROWIRE Output Propagation Delay (t _{UPD})				220	ns
MICROWIRE Maximum Shift Clock					
Master Mode				500	kHz
Slave Mode				1	MHz
Input Pulse Width (Note 6)					
Interrupt Input High Time		1			t _C
Interrupt Input Low Time		1			t _C
Timer 1, 2, 3 Input High Time		1			t _C
Timer 1, 2, 3 Input Low Time		1			t _C
Reset Pulse Width		1			μs

5.0 Pin Descriptions

COP8SAx I/O structure minimizes external component requirements. Software-switchable I/O enables designers to reconfigure the microcontroller's I/O functions with a single instruction. Each individual I/O pin can be independently configured as an output pin low, an output high, an input with high impedance or an input with a weak pull-up device. A typical example is the use of I/O pins as the keyboard matrix input lines. The input lines can be programmed with internal weak pull-ups so that the input lines read logic high when the keys are all up. With a key closure, the corresponding input line will read a logic zero since the weak pull-up can easily be overdriven. When the key is released, the internal weak pullup will pull the input line back to logic high. This flexibility eliminates the need for external pull-up resistors. The High current options are available for driving LEDs, motors and speakers. This flexibility helps to ensure a cleaner design, with less external components and lower costs. Below is the general description of all available pins.

V_{CC} and GND are the power supply pins. All V_{CC} and GND pins must be connected.

CKI is the clock input. This can come from the Internal R/C oscillator, external, or a crystal oscillator (in conjunction with CKO). See Oscillator Description section.

RESET is the master reset input. See Reset description section.

The device contains four bidirectional 8-bit I/O ports (C, G, L and F), where each individual bit may be independently configured as an input (Schmitt trigger inputs on ports L and G), output or TRI-STATE under program control. Three data memory address locations are allocated for each of these I/O ports. Each I/O port has two associated 8-bit memory mapped registers, the CONFIGURATION register and the output DATA register. A memory mapped address is also reserved for the input pins of each I/O port. (See the memory map for the various addresses associated with the I/O ports.) *Figure 5* shows the I/O port configurations. The DATA and CONFIGURATION registers allow for each port bit to be individually configured under software control as shown below:

CONFIGURATION Register	DATA Register	Port Set-Up
0	0	Hi-Z Input (TRI-STATE Output)
0	1	Input with Weak Pull-Up
1	0	Push-Pull Zero Output
1	1	Push-Pull One Output

Port L is an 8-bit I/O port. All L-pins have Schmitt triggers on the inputs.

Port L supports the Multi-Input Wake Up feature on all eight pins. The 16-pin device does not have a full complement of Port L pins. The unavailable pins are not terminated. A read operation these unterminated pins are not terminated. A read operation these unterminated pins will return unpredictable values. To minimize current drain, the unavailable pins must be programmed as outputs.

Port G is an 8-bit port. Pin G0, G2–G5 are bi-directional I/O ports. Pin G6 is always a general purpose Hi-Z input. All pins have Schmitt Triggers on their inputs. **Pin G1 serves as the dedicated WDOUT WATCHDOG output with weak pullup if WATCHDOG feature is selected by the ECON register.**

The pin is a general purpose I/O if WATCHDOG feature is not selected. If WATCHDOG feature is selected, bit 1 of the Port G configuration and data register does not have any effect on Pin G1 setup. Pin G7 is either input or output depending on the oscillator option selected. With the crystal oscillator option selected, G7 serves as the dedicated output pin for the CKO clock output. With the internal R/C or the external oscillator option selected, G7 serves as a general purpose Hi-Z input pin and is also used to bring the device out of HALT mode with a low to high transition on G7. There are two registers associated with Port G, a data register and a configuration register. Using these registers, each of the 5 I/O pins (G0, G2–G5) can be individually configured under software control.

Since G6 is an input only pin and G7 is the dedicated CKO clock output pin (crystal clock option) or general purpose input (R/C or external clock option), the associated bits in the data and configuration registers for G6 and G7 are used for special purpose functions as outlined below. Reading the G6 and G7 data bits will return zeroes.

The device will be placed in the HALT mode by writing a "1" to bit 7 of the Port G Data Register. Similarly the device will be placed in the IDLE mode by writing a "1" to bit 6 of the Port G Data Register.

Writing a "1" to bit 6 of the Port G Configuration Register enables the MICROWIRE/PLUS to operate with the alternate phase of the SK clock. The G7 configuration bit, if set high, enables the clock start up delay after HALT when the R/C clock configuration is used.

	Config. Reg.	Data Reg.
G7	CLKDLY	HALT
G6	Alternate SK	IDLE

Port G has the following alternate features:

- G6 SI (MICROWIRE Serial Data Input)
- G5 SK (MICROWIRE Serial Clock)
- G4 SO (MICROWIRE Serial Data Output)
- G3 T1A (Timer T1 I/O)
- G2 T1B (Timer T1 Capture Input)
- G0 INTR (External Interrupt Input)

Port G has the following dedicated functions:

- G7 CKO Oscillator dedicated output or general purpose input
- G1 WDOUT WATCHDOG and/or CLock Monitor if WATCHDOG enabled, otherwise it is a general purpose I/O

Port C is an 8-bit I/O port. The 40-pin device does not have a full complement of Port C pins. The unavailable pins are not terminated. A read operation on these unterminated pins will return unpredictable values. Only the COP8SAC7 device contains Port C. The 20/28 pin devices do not offer Port C. On these devices, the associated Port C Data and Configuration registers should not be used.

Port F is an 8-bit I/O port. The 28-pin device does not have a full complement of Port F pins. The unavailable pins are not terminated. A read operation on these unterminated pins will return unpredictable values.

5.0 Pin Descriptions (Continued)

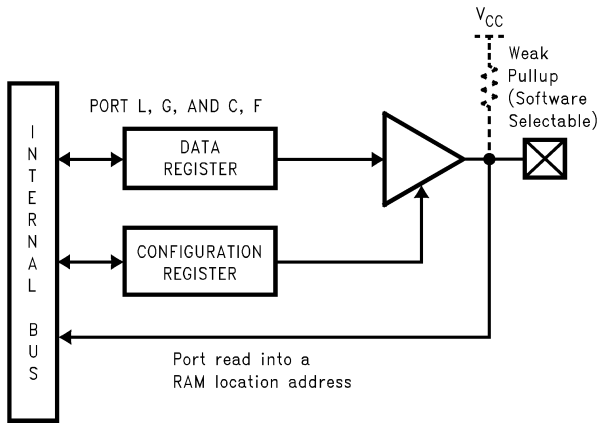

DS012838-10

FIGURE 5. I/O Port Configurations

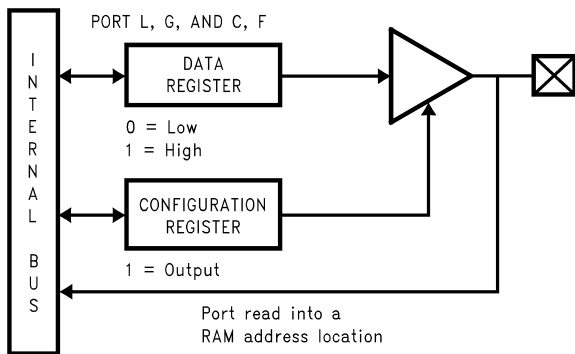

DS012838-12

FIGURE 6. I/O Port Configurations—Output Mode

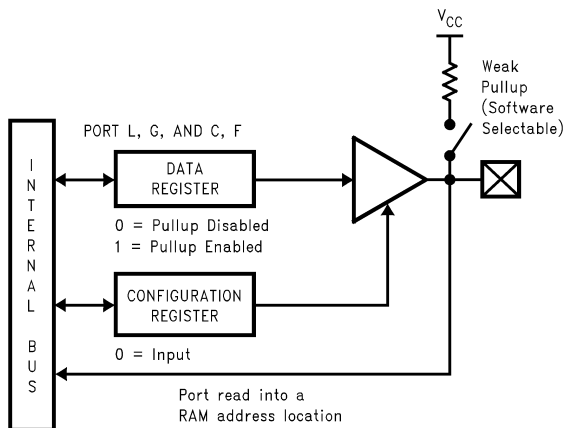

DS012838-11

FIGURE 7. I/O Port Configurations—Input Mode

Port D is an 8-bit output port that is preset high when $\overline{\text{RESET}}$ goes low. The user can tie two or more D port outputs (except D2) together in order to get a higher drive.

Note: Care must be exercised with the D2 pin operation. At $\overline{\text{RESET}}$, the external loads on this pin must ensure that the output voltages stay above $0.7 V_{CC}$ to prevent the chip from entering special modes. Also keep the external loading on D2 to less than 1000 pF.

6.0 Functional Description

The architecture of the device is a modified Harvard architecture. With the Harvard architecture, the program memory EPROM is separated from the data store memory (RAM). Both EPROM and RAM have their own separate addressing space with separate address buses. The architecture, though based on the Harvard architecture, permits transfer of data from EPROM to RAM.

6.1 CPU REGISTERS

The CPU can do an 8-bit addition, subtraction, logical or shift operation in one instruction (t_c) cycle time.

There are six CPU registers:

A is the 8-bit Accumulator Register

PC is the 15-bit Program Counter Register

PU is the upper 7 bits of the program counter (PC)

PL is the lower 8 bits of the program counter (PC)

B is an 8-bit RAM address pointer, which can be optionally post auto incremented or decremented.

X is an 8-bit alternate RAM address pointer, which can be optionally post auto incremented or decremented.

SP is the 8-bit stack pointer, which points to the subroutine/interrupt stack (in RAM). With reset the SP is initialized to RAM address 02F Hex (devices with 64 bytes of RAM), or initialized to RAM address 06F Hex (devices with 128 bytes of RAM).

All the CPU registers are memory mapped with the exception of the Accumulator (A) and the Program Counter (PC).

6.2 PROGRAM MEMORY

The program memory consists of 1024, 2048, or 4096 bytes of EPROM or ROM. *Table 1* shows the program memory sizes for the different devices. These bytes may hold program instructions or constant data (data tables for the LAID instruction, jump vectors for the JID instruction, and interrupt vectors for the VIS instruction). The program memory is addressed by the 15-bit program counter (PC). All interrupts in the device vector to program memory location 0FF Hex. The program memory reads 00 Hex in the erased state.

6.3 DATA MEMORY

The data memory address space includes the on-chip RAM and data registers, the I/O registers (Configuration, Data and Pin), the control registers, the MICROWIRE/PLUS SIO shift register, and the various registers, and counters associated with the timers (with the exception of the IDLE timer). Data memory is addressed directly by the instruction or indirectly by the B, X and SP pointers.

The data memory consists of 64 or 128 bytes of RAM. *Table 1* shows the data memory sizes for the different devices. Fifteen bytes of RAM are mapped as "registers" at addresses 0F0 to 0FE Hex. These registers can be loaded immediately, and also decremented and tested with the DRSZ (decrement register and skip if zero) instruction. The memory pointer registers X, SP and B are memory mapped into this space at address locations 0FC to 0FE Hex respectively, with the other registers (except 0FF) being available for general usage. Address location 0FF is reserved for future RAM expansion. If compatibility with future devices (with more RAM) is not desired, this location can be used as a general purpose RAM location.

The instruction set permits any bit in memory to be set, reset or tested. All I/O and registers (except A and PC) are

6.0 Functional Description (Continued)

memory mapped; therefore, I/O bits and register bits can be directly and individually set, reset and tested. The accumulator (A) bits can also be directly and individually tested. RAM contents are undefined upon power-up.

TABLE 1. Program/Data Memory Sizes

Device	Program Memory (Bytes)	Data Memory (Bytes)	User Storage (Bytes)
COP8SAA7	1024	64	8
COP8SAB7	2048	128	8
COP8SAC7	4096	128	8

6.4 ECON (CONFIGURATION) REGISTER

The ECON register is used to configure the user selectable clock, security, power-on reset, WATCHDOG, and HALT options. The register can be programmed and read only in EPROM programming mode. Therefore, the register should be programmed at the same time as the program memory. The contents of the ECON register shipped from the factory read 00 Hex (windowed device), 80 Hex (OTP device) or as specified by the customer (ROM device).

The format of the ECON register is as follows:

Bit 7	Bit 6	Bit 5	Bit 4	Bit 3	Bit 2	Bit 1	Bit 0
X	POR	SECURITY	CKI 2	CKI 1	WATCH DOG	Reserved	HALT

Bit 7	= x	This is for factory test. The polarity is always 0.
Bit 6	= 1	Power-on reset enabled.
	= 0	Power-on reset disabled.
Bit 5	= 1	Security enabled. EPROM read and write are not allowed.
	= 0	Security disabled. EPROM read and write are allowed.
Bits 4, 3 = 0, 0		External CKI option selected. G7 is available as a HALT restart and/or general purpose input. CKI is clock input.
	= 0, 1	R/C oscillator option selected. G7 is available as a HALT restart and/or general purpose input. CKI clock input. Internal R/C components are supplied for maximum R/C frequency.
	= 1, 0	Crystal oscillator with on-chip crystal bias resistor disabled. G7 (CKO) is the clock generator output to crystal/resonator.
	= 1, 1	Crystal oscillator with on-chip crystal bias resistor enabled. G7 (CKO) is the clock generator output to crystal/resonator.
Bit 2	= 1	WATCHDOG feature disabled. G1 is a general purpose I/O.
	= 0	WATCHDOG feature enabled. G1 pin is WATCHDOG output with waek pullup.
Bit 1	=	Reserved.
Bit 0	= 1	HALT mode disabled.
	= 0	HALT mode enabled.

6.5 USER STORAGE SPACE IN EPROM

In addition to the ECON register, there are 8 bytes of EPROM available for "user information". ECON and these 8 bytes are outside of the code area and are not protected by the security bit of the ECON register. Even when security is set, information in the 8-byte USER area is both read and write enabled allowing the user to read from and write into the area at all times while still protecting the code from unauthorized access.

Both ECON and USER area, 9 bytes total, are outside of the normal address range of the EPROM and can not be accessed by the executing software. This allows for the storage of non-secured information. Typical uses are for storage of serial numbers, data codes, version numbers, copyright information, lot numbers, etc.

The COP8 assembler defines a special ROM section type, CONF, into which the ECON and USER data may be coded. Both ECON and User Data are programmed automatically by programmers that are certified by National.

The following examples illustrate the declaration of ECON and the User information.

Syntax:

```
[label:] .sect econ, conf
        .db value ;1 byte,
                ;configures options
        .db
        .endsect<user information>
                ;up to 8 bytes
```

Example: The following sets a value in the ECON register and User Identification for a COP8SAC728M7. The ECON bit values shown select options: Power-on enabled, Security disabled, Crystal oscillator with on-chip bias disabled, WATCHDOG enabled and HALT mode enabled.

```
.chip 8SAC
.sect econ, conf
.db 0x55 ;por, extal, wd, halt
.db 'my v1.00' ;user data declaration
.endsect
...
.end start
```

Note: All programmers certified for programming this family of parts will support programming of the CONFfiguration section. Please contact National or your device programmer supplier for more information.

6.6 OTP SECURITY

The device has a security feature that, when enabled, prevents external reading of the OTP program memory. The security bit in the ECON register determines, whether security is enabled or disabled. If the security feature is disabled, the contents of the internal EPROM may be read.

If the security feature is enabled, then any attempt to externally read the contents of the EPROM will result in the value FF Hex being read from all program locations. Under no circumstances can a secured part be read. In addition, with the security feature enabled, the write operation to the EPROM program memory and ECON register is inhibited. The ECON register is readable regardless of the state of the security bit. The security bit, when set, **cannot** be erased, **even in windowed packages**. If the security bit is set in a device in a windowed package, that device may be erased but will not be further programmable.

If security is being used, it is recommended that all other bits in the ECON register be programmed first. Then the security bit can be programmed.

6.0 Functional Description (Continued)

6.7 RESET

The device is initialized when the $\overline{\text{RESET}}$ pin is pulled low or the On-chip Power-On Reset is enabled.

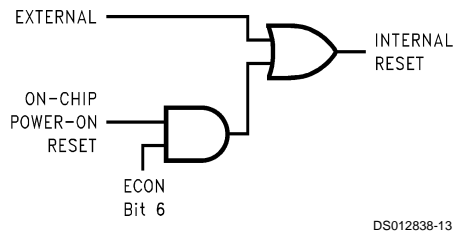

FIGURE 8. Reset Logic

The following occurs upon initialization:

- Port L: TRISTATE
- Port C: TRISTATE
- Port G: TRISTATE
- Port F: TRISTATE
- Port D: HIGH
- PC: CLEARED to 0000
- PSW, CNTRL and ICNTRL registers: CLEARED
- SIOR: UNAFFECTED after RESET with power already applied
- RANDOM after RESET at power-on
- T1CNTRL: CLEARED
- Accumulator, Timer 1:
 - RANDOM after RESET with crystal clock option (power already applied)
 - UNAFFECTED after RESET with R/C clock option (power already applied)
 - RANDOM after RESET at power-on
- WKEN, WKEDG: CLEARED
- WKPND: RANDOM
- SP (Stack Pointer):
 - Initialized to RAM address 02F Hex (devices with 64 bytes of RAM), or initialized to RAM address 06F Hex (devices with 128 bytes of RAM).
- B and X Pointers:
 - UNAFFECTED after RESET with power already applied
 - RANDOM after RESET at power-on
- RAM:
 - UNAFFECTED after RESET with power already applied
 - RANDOM after RESET at power-on
- WATCHDOG (if enabled):

The device comes out of reset with both the WATCHDOG logic and the Clock Monitor detector armed, with the WATCHDOG service window bits set and the Clock Monitor bit set. The WATCHDOG and Clock Monitor circuits are inhibited during reset. The WATCHDOG service window bits being initialized high default to the maximum WATCHDOG service window of $64k t_C$ clock cycles. The Clock Monitor bit being initialized high will cause a Clock Monitor error following reset if the clock has not reached the minimum specified

frequency at the termination of reset. A Clock Monitor error will cause an active low error output on pin G1. This error output will continue until $16 t_C - 32 t_C$ clock cycles following the clock frequency reaching the minimum specified value, at which time the G1 output will go high.

6.7.1 External Reset

The $\overline{\text{RESET}}$ input when pulled low initializes the device. The $\overline{\text{RESET}}$ pin must be held low for a minimum of one instruction cycle to guarantee a valid reset. During Power-Up initialization, the user must ensure that the $\overline{\text{RESET}}$ pin is held low until the device is within the specified V_{CC} voltage. An R/C circuit on the $\overline{\text{RESET}}$ pin with a delay 5 times ($5x$) greater than the power supply rise time or $15 \mu s$ whichever is greater, is recommended. Reset should also be wide enough to ensure crystal start-up upon Power-Up.

$\overline{\text{RESET}}$ may also be used to cause an exit from the HALT mode.

A recommended reset circuit for this device is shown in Figure 9.

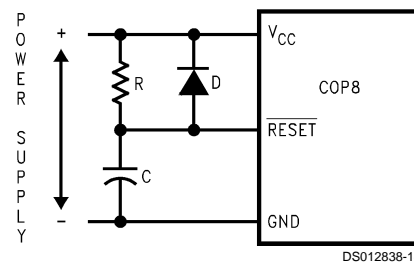

$RC > 5x$ power supply rise time or $15 \mu s$, whichever is greater.

FIGURE 9. Reset Circuit Using External Reset

6.7.2 On-Chip Power-On Reset

The on-chip reset circuit is selected by a bit in the ECON register. When enabled, the device generates an internal reset as V_{CC} rises to a voltage level above 2.0V. The on-chip reset circuitry is able to detect both fast and slow rise times on V_{CC} (V_{CC} rise time between 10 ns and 50 ms).

Under no circumstances should the $\overline{\text{RESET}}$ pin be allowed to float. If the on-chip Power-On Reset feature is being used, $\overline{\text{RESET}}$ pin should be connected directly to V_{CC} . The output of the power-on reset detector will **always** preset the Idle timer to 0FFF ($4096 t_C$). At this time, the internal reset will be generated.

If the Power-On Reset feature is enabled, the internal reset will not be turned off until the Idle timer underflows. The internal reset will perform the same functions as external reset. The user is responsible for ensuring that V_{CC} is at the minimum level for the operating frequency within the $4096 t_C$. After the underflow, the logic is designed such that no additional internal resets occur as long as V_{CC} remains above 2.0V.

Note: While the POR feature of the COP8SAx was never intended to function as a brownout detector, there are certain constraints of this block that the system designer must address to properly recover from a brownout condition. This is true regardless of whether the internal POR or the external reset feature is used.

A brownout condition is reached when V_{CC} of the device goes below the minimum operating conditions of the device. The minimum guaranteed operating conditions are defined as $V_{CC} = 4.5V @ 10 \text{ MHz CKI}$, $V_{CC} = 2.7V @ 4 \text{ MHz}$, or $V_{CC} = 2.0V$ during HALT mode (or when CKI is stopped) operation.

When using either the external reset or the POR feature to recover from a brownout condition, V_{CC} must be lowered to 0.25V or an external reset must be applied whenever it goes below the minimum operating conditions as stated above.

6.0 Functional Description (Continued)

The contents of data registers and RAM are unknown following the on-chip reset.

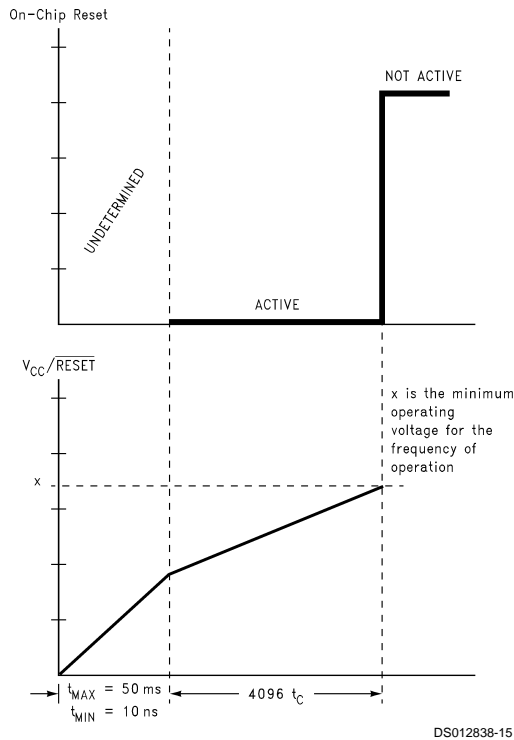

FIGURE 10. Reset Timing (Power-On Reset Enabled) with V_{CC} Tied to RESET

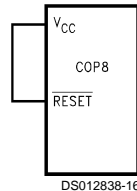

FIGURE 11. Reset Circuit Using Power-On Reset

6.8 OSCILLATOR CIRCUITS

There are four clock oscillator options available: Crystal Oscillator with or without on-chip bias resistor, R/C Oscillator with on-chip resistor and capacitor, and External Oscillator. The oscillator feature is selected by programming the ECON register, which is summarized in *Table 2*.

TABLE 2. Oscillator Option

ECON4	ECON3	Oscillator Option
0	0	External Oscillator
1	0	Crystal Oscillator without Bias Resistor
0	1	R/C Oscillator
1	1	Crystal Oscillator with Bias Resistor

6.8.1 Crystal Oscillator

The crystal Oscillator mode can be selected by programming ECON Bit 4 to 1. CKI is the clock input while G7/CKO is the clock generator output to the crystal. An on-chip bias resistor connected between CKI and CKO can be enabled by programming ECON Bit 3 to 1 with the crystal oscillator option selection. The value of the resistor is in the range of 0.5M to 2M (typically 1.0M). *Table 3* shows the component values required for various standard crystal values. Resistor R2 is only used when the on-chip bias resistor is disabled. *Figure 12* shows the crystal oscillator connection diagram.

TABLE 3. Crystal Oscillator Configuration, $T_A = 25^\circ\text{C}$, $V_{CC} = 5\text{V}$

R1 (k Ω)	R2 (M Ω)	C1 (pF)	C2 (pF)	CKI Freq. (MHz)
0	1	30	30	15
0	1	32	32	10
0	1	45	30–36	4
5.6	1	100	100–156	0.455

6.8.2 External Oscillator

The External Oscillator mode can be selected by programming ECON Bit 3 to 0 and ECON Bit 4 to 0. CKI can be driven by an external clock signal provided it meets the specified duty cycle, rise and fall times, and input levels. G7/CKO is available as a general purpose input G7 and/or Halt control. *Figure 13* shows the external oscillator connection diagram.

6.8.3 R/C Oscillator

The R/C Oscillator mode can be selected by programming ECON Bit 3 to 1 and ECON Bit 4 to 0. In R/C oscillation mode, CKI is left floating, while G7/CKO is available as a general purpose input G7 and/or HALT control. The R/C controlled oscillator has on-chip resistor and capacitor for maximum R/C oscillator frequency operation. The maximum frequency is 6 MHz \pm 35% for V_{CC} between 4.5V to 5.5V and temperature range of -40°C to $+85^\circ\text{C}$. For max frequency operation, the CKI pin should be left floating. For lower frequencies, an external capacitor should be connected between CKI and either V_{CC} or GND. Immunity of the R/C oscillator to external noise can be improved by connecting one half the external capacitance to V_{CC} and one half to GND. PC board trace length on the CKI pin should be kept as short as possible. *Table 4* shows the oscillator frequency as a function of approximate external capacitance on the CKI pin. *Figure 14* shows the R/C oscillator configuration.

TABLE 4. R/C Oscillator Configuration, -40°C to $+85^\circ\text{C}$, $V_{CC} = 4.5\text{V}$ to 5.5V , OSC Freq. Variation of $\pm 35\%$

External Capacitor (pF)	R/C OSC Freq (MHz)	Instr. Cycle (μs)
0	6	1.667
13	4	2.5
62	2	5.0
120	1	10
5600	32 kHz	312.5

6.0 Functional Description (Continued)

With On-Chip Bias Resistor

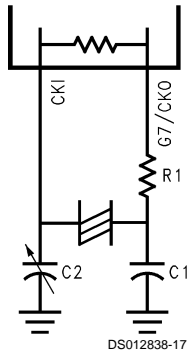

Without On-Chip Bias Resistor

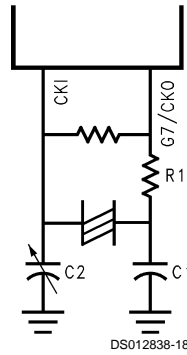

FIGURE 12. Crystal Oscillator

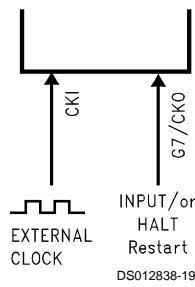
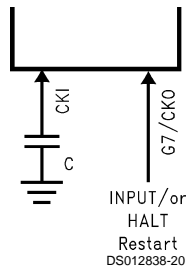
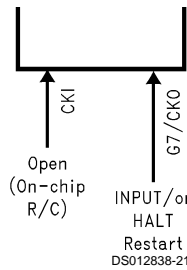

FIGURE 13. External Oscillator



For operation at lower than maximum R/C oscillator frequency.



For operation at maximum R/C oscillator frequency.

FIGURE 14. R/C Oscillator

6.0 Functional Description (Continued)

6.9 CONTROL REGISTERS

CNTRL Register (Address X'00EE)

T1C3	T1C2	T1C1	T1C0	MSEL	IEDG	SL1	SL0
Bit 7							Bit 0

The Timer1 (T1) and MICROWIRE/PLUS control register contains the following bits:

T1C3	Timer T1 mode control bit
T1C2	Timer T1 mode control bit
T1C1	Timer T1 mode control bit
T1C0	Timer T1 Start/Stop control in timer modes 1 and 2, T1 Underflow Interrupt Pending Flag in timer mode 3
MSEL	Selects G5 and G4 as MICROWIRE/PLUS signals SK and SO respectively
IEDG	External interrupt edge polarity select (0 = Rising edge, 1 = Falling edge)
SL1 & SL0	Select the MICROWIRE/PLUS clock divide by (00 = 2, 01 = 4, 1x = 8)

PSW Register (Address X'00EF)

HC	C	T1PNDA	T1ENA	EXPND	BUSY	EXEN	GIE
Bit 7							Bit 0

The PSW register contains the following select bits:

HC	Half Carry Flag
C	Carry Flag
T1PNDA	Timer T1 Interrupt Pending Flag (Autoreload RA in mode 1, T1 Underflow in Mode 2, T1A capture edge in mode 3)
T1ENA	Timer T1 Interrupt Enable for Timer Underflow or T1A Input capture edge
EXPND	External interrupt pending
BUSY	MICROWIRE/PLUS busy shifting flag
EXEN	Enable external interrupt
GIE	Global interrupt enable (enables interrupts)

The Half-Carry flag is also affected by all the instructions that affect the Carry flag. The SC (Set Carry) and R/C (Reset Carry) instructions will respectively set or clear both the carry flags. In addition to the SC and R/C instructions, ADC, SUBC, RRC and RLC instructions affect the Carry and Half Carry flags.

ICNTRL Register (Address X'00E8)

Reserved	LPEN	TOPND	T0EN	μ WPND	μ WEN	T1PNDB	T1ENB
Bit 7							Bit 0

The ICNTRL register contains the following bits:

Reserved	This bit is reserved and should to zero
LPEN	L Port Interrupt Enable (Multi-Input Wakeup/Interrupt)
TOPND	Timer T0 Interrupt pending
T0EN	Timer T0 Interrupt Enable (Bit 12 toggle)
μ WPND	MICROWIRE/PLUS interrupt pending
μ WEN	Enable MICROWIRE/PLUS interrupt
T1PNDB	Timer T1 Interrupt Pending Flag for T1B capture edge

T1ENB Timer T1 Interrupt Enable for T1B Input capture edge

7.0 Timers

The device contains a very versatile set of timers (T0, T1). Timer T1 and associated autoreload/capture registers power up containing random data.

7.1 TIMER T0 (IDLE TIMER)

The device supports applications that require maintaining real time and low power with the IDLE mode. This IDLE mode support is furnished by the IDLE timer T0. The Timer T0 runs continuously at the fixed rate of the instruction cycle clock, t_c . The user cannot read or write to the IDLE Timer T0, which is a count down timer.

The Timer T0 supports the following functions:

- Exit out of the Idle Mode (See Idle Mode description)
- WATCHDOG logic (See WATCHDOG description)
- Start up delay out of the HALT mode
- Timing the width of the internal power-on-reset

The IDLE Timer T0 can generate an interrupt when the twelfth bit toggles. This toggle is latched into the TOPND pending flag, and will occur every 4.096 ms at the maximum clock frequency ($t_c = 1 \mu s$). A control flag T0EN allows the interrupt from the twelfth bit of Timer T0 to be enabled or disabled. Setting T0EN will enable the interrupt, while resetting it will disable the interrupt.

7.2 TIMER T1

One of the main functions of a microcontroller is to provide timing and counting capability for real-time control tasks. The COP8 family offers a very versatile 16-bit timer/counter structure, and two supporting 16-bit autoreload/capture registers (R1A and R1B), optimized to reduce software burdens in real-time control applications. The timer block has two pins associated with it, T1A and T1B. Pin T1A supports I/O required by the timer block, while pin T1B is an input to the timer block.

The timer block has three operating modes: Processor Independent PWM mode, External Event Counter mode, and Input Capture mode.

The control bits T1C3, T1C2, and T1C1 allow selection of the different modes of operation.

7.2.1 Mode 1. Processor Independent PWM Mode

One of the timer's operating modes is the Processor Independent PWM mode. In this mode, the timer generates a "Processor Independent" PWM signal because once the timer is setup, no more action is required from the CPU which translates to less software overhead and greater throughput. The user software services the timer block only when the PWM parameters require updating. This capability is provided by the fact that the timer has two separate 16-bit reload registers. One of the reload registers contains the "ON" timer while the other holds the "OFF" time. By contrast, a microcontroller that has only a single reload register requires an additional software to update the reload value (alternate between the on-time/off-time).

The timer can generate the PWM output with the width and duty cycle controlled by the values stored in the reload registers. The reload registers control the countdown values and the reload values are automatically written into the timer when it counts down through 0, generating interrupt on each reload. Under software control and with minimal overhead,

7.0 Timers (Continued)

the PWM outputs are useful in controlling motors, triacs, the intensity of displays, and in providing inputs for data acquisition and sine wave generators.

In this mode, the timer T1 counts down at a fixed rate of t_c . Upon every underflow the timer is alternately reloaded with the contents of supporting registers, R1A and R1B. The very first underflow of the timer causes the timer to reload from the register R1A. Subsequent underflows cause the timer to be reloaded from the registers alternately beginning with the register R1B.

The T1 Timer control bits, T1C3, T1C2 and T1C1 set up the timer for PWM mode operation.

Figure 15 shows a block diagram of the timer in PWM mode.

The underflows can be programmed to toggle the T1A output pin. The underflows can also be programmed to generate interrupts.

Underflows from the timer are alternately latched into two pending flags, T1PNDA and T1PNDB. The user must reset these pending flags under software control. Two control enable flags, T1ENA and T1ENB, allow the interrupts from the timer underflow to be enabled or disabled. Setting the timer enable flag T1ENA will cause an interrupt when a timer underflow causes the R1A register to be reloaded into the timer. Setting the timer enable flag T1ENB will cause an interrupt when a timer underflow causes the R1B register to be reloaded into the timer. Resetting the timer enable flags will disable the associated interrupts.

Either or both of the timer underflow interrupts may be enabled. This gives the user the flexibility of interrupting once per PWM period on either the rising or falling edge of the PWM output. Alternatively, the user may choose to interrupt on both edges of the PWM output.

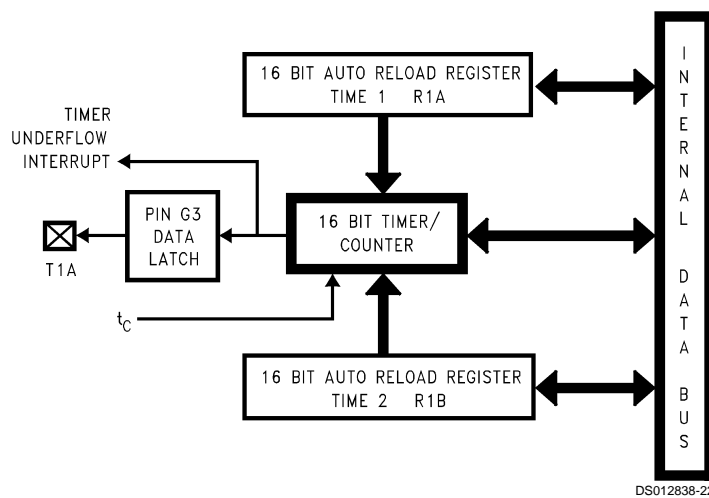

FIGURE 15. Timer in PWM Mode

7.2.2 Mode 2. External Event Counter Mode

This mode is quite similar to the processor independent PWM mode described above. The main difference is that the timer, T1, is clocked by the input signal from the T1A pin. The T1 timer control bits, T1C3, T1C2 and T1C1 allow the timer to be clocked either on a positive or negative edge from the T1A pin. Underflows from the timer are latched into the T1PNDA pending flag. Setting the T1ENA control flag will cause an interrupt when the timer underflows.

In this mode the input pin T1B can be used as an independent positive edge sensitive interrupt input if the T1ENB control flag is set. The occurrence of a positive edge on the T1B input pin is latched into the T1PNDB flag.

Figure 16 shows a block diagram of the timer in External Event Counter mode.

Note: The PWM output is not available in this mode since the T1A pin is being used as the counter input clock.

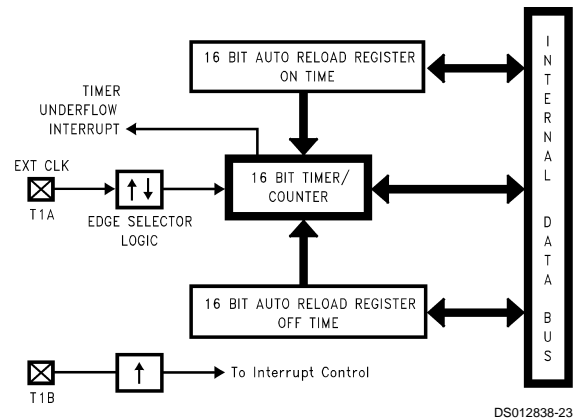

FIGURE 16. Timer in External Event Counter Mode

7.0 Timers (Continued)

7.2.3 Mode 3. Input Capture Mode

The device can precisely measure external frequencies or time external events by placing the timer block, T1, in the input capture mode. In this mode, the reload registers serve as independent capture registers, capturing the contents of the timer when an external event occurs (transition on the timer input pin). The capture registers can be read while maintaining count, a feature that lets the user measure elapsed time and time between events. By saving the timer value when the external event occurs, the time of the external event is recorded. Most microcontrollers have a latency time because they cannot determine the timer value when the external event occurs. The capture register eliminates the latency time, thereby allowing the applications program to retrieve the timer value stored in the capture register.

In this mode, the timer T1 is constantly running at the fixed t_c rate. The two registers, R1A and R1B, act as capture registers. Each register acts in conjunction with a pin. The register R1A acts in conjunction with the T1A pin and the register R1B acts in conjunction with the T1B pin.

The timer value gets copied over into the register when a trigger event occurs on its corresponding pin. Control bits, T1C3, T1C2 and T1C1, allow the trigger events to be speci-

fied either as a positive or a negative edge. The trigger condition for each input pin can be specified independently.

The trigger conditions can also be programmed to generate interrupts. The occurrence of the specified trigger condition on the T1A and T1B pins will be respectively latched into the pending flags, T1PNDA and T1PNDB. The control flag T1ENA allows the interrupt on T1A to be either enabled or disabled. Setting the T1ENA flag enables interrupts to be generated when the selected trigger condition occurs on the T1A pin. Similarly, the flag T1ENB controls the interrupts from the T1B pin.

Underflows from the timer can also be programmed to generate interrupts. Underflows are latched into the timer T1C0 pending flag (the T1C0 control bit serves as the timer underflow interrupt pending flag in the Input Capture mode). Consequently, the T1C0 control bit should be reset when entering the Input Capture mode. The timer underflow interrupt is enabled with the T1ENA control flag. When a T1A interrupt occurs in the Input Capture mode, the user must check both the T1PNDA and T1C0 pending flags in order to determine whether a T1A input capture or a timer underflow (or both) caused the interrupt.

Figure 17 shows a block diagram of the timer in Input Capture mode.

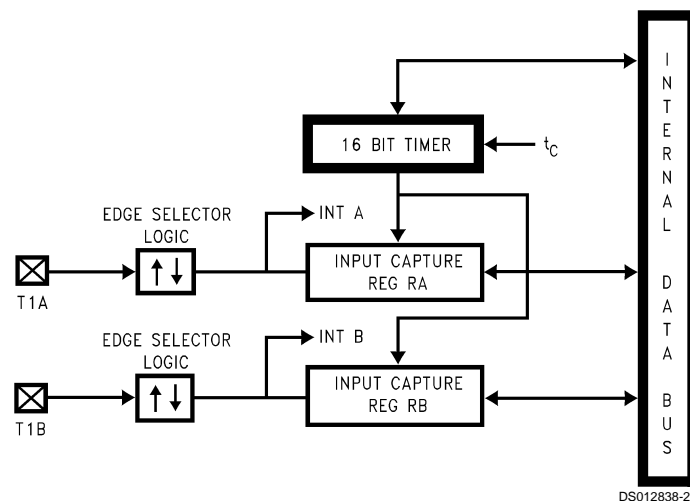

FIGURE 17. Timer in Input Capture Mode

7.0 Timers (Continued)

7.3 TIMER CONTROL FLAGS

The control bits and their functions are summarized below.

T1C3	Timer mode control
T1C2	Timer mode control
T1C1	Timer mode control
T1C0	Timer Start/Stop control in Modes 1 and 2 (Processor Independent PWM and External Event Counter), where 1 = Start, 0 = Stop
	Timer Underflow Interrupt Pending Flag in Mode 3 (Input Capture)

T1PNDA	Timer Interrupt Pending Flag
T1ENA	Timer Interrupt Enable Flag
	1 = Timer Interrupt Enabled
	0 = Timer Interrupt Disabled
T1PNDB	Timer Interrupt Pending Flag
T1ENB	Timer Interrupt Enable Flag
	1 = Timer Interrupt Enabled
	0 = Timer Interrupt Disabled

The timer mode control bits (T1C3, T1C2 and T1C1) are detailed below:

Mode	T1C3	T1C2	T1C1	Description	Interrupt A Source	Interrupt B Source	Timer Counts On
1	1	0	1	PWM: T1A Toggle	Autoreload RA	Autoreload RB	t_c
	1	0	0	PWM: No T1A Toggle	Autoreload RA	Autoreload RB	t_c
2	0	0	0	External Event Counter	Timer Underflow	Pos. T1B Edge	Pos. T1A Edge
	0	0	1	External Event Counter	Timer Underflow	Pos. T1B Edge	Pos. T1A Edge
3	0	1	0	Captures: T1A Pos. Edge T1B Pos. Edge	Pos. T1A Edge or Timer Underflow	Pos. T1B Edge	t_c
	1	1	0	Captures: T1A Pos. Edge T1B Neg. Edge	Pos. T1A Edge or Timer Underflow	Neg. T1B Edge	t_c
	0	1	1	Captures: T1A Neg. Edge T1B Neg. Edge	Neg. T1A Edge or Timer Underflow	Neg. T1B Edge	t_c
	1	1	1	Captures: T1A Neg. Edge T1B Neg. Edge	Neg. T1A Edge or Timer Underflow	Neg. T1B Edge	t_c

8.0 Power Save Modes

Today, the proliferation of battery-operated based applications has placed new demands on designers to drive power consumption down. Battery-operated systems are not the only type of applications demanding low power. The power budget constraints are also imposed on those consumer/industrial applications where well regulated and expensive power supply costs cannot be tolerated. Such applications rely on low cost and low power supply voltage derived directly from the “mains” by using voltage rectifier and passive components. Low power is demanded even in automotive applications, due to increased vehicle electronics content. This is required to ease the burden from the car battery. Low power 8-bit microcontrollers supply the smarts to control battery-operated, consumer/industrial, and automotive applications.

The COP8SAx devices offer system designers a variety of low-power consumption features that enable them to meet the demanding requirements of today's increasing range of low-power applications. These features include low voltage operation, low current drain, and power saving features such as HALT, IDLE, and Multi-Input wakeup (MIWU).

The devices offer the user two power save modes of operation: HALT and IDLE. In the HALT mode, all microcontroller activities are stopped. In the IDLE mode, the on-board oscillator circuitry and timer T0 are active but all other microcontroller activities are stopped. In either mode, all on-board RAM, registers, I/O states, and timers (with the exception of T0) are unaltered.

Clock Monitor if enabled can be active in both modes.

8.1 HALT MODE

The device can be placed in the HALT mode by writing a “1” to the HALT flag (G7 data bit). All microcontroller activities, including the clock and timers, are stopped. The WATCHDOG logic on the device is disabled during the HALT mode. However, the clock monitor circuitry, if enabled, remains active and will cause the WATCHDOG output pin (WDOOUT) to go low. If the HALT mode is used and the user does not want to activate the WDOOUT pin, the Clock Monitor should be disabled after the device comes out of reset (resetting the Clock Monitor control bit with the first write to the WDSVR register). In the HALT mode, the power requirements of the device are minimal and the applied voltage (V_{CC}) may be decreased to V_r ($V_r = 2.0V$) without altering the state of the machine.

The device supports three different ways of exiting the HALT mode. The first method of exiting the HALT mode is with the Multi-Input Wakeup feature on Port L. The second method is

with a low to high transition on the CKO (G7) pin. This method precludes the use of the crystal clock configuration (since CKO becomes a dedicated output), and so may only be used with an R/C clock configuration. The third method of exiting the HALT mode is by pulling the \overline{RESET} pin low.

Since a crystal or ceramic resonator may be selected as the oscillator, the Wakeup signal is not allowed to start the chip running immediately since crystal oscillators and ceramic resonators have a delayed start up time to reach full amplitude and frequency stability. The IDLE timer is used to generate a fixed delay to ensure that the oscillator has indeed stabilized before allowing instruction execution. In this case, upon detecting a valid Wakeup signal, only the oscillator circuitry is enabled. The IDLE timer is loaded with a value of 256 and is clocked with the t_C instruction cycle clock. The t_C clock is derived by dividing the oscillator clock down by a factor of 10. The Schmitt trigger following the CKI inverter on the chip ensures that the IDLE timer is clocked only when the oscillator has a sufficiently large amplitude to meet the Schmitt trigger specifications. This Schmitt trigger is not part of the oscillator closed loop. The start-up time-out from the IDLE timer enables the clock signals to be routed to the rest of the chip.

If an R/C clock option is being used, the fixed delay is introduced optionally. A control bit, CLKDLY, mapped as configuration bit G7, controls whether the delay is to be introduced or not. The delay is included if CLKDLY is set, and excluded if CLKDLY is reset. The CLKDLY bit is cleared on reset.

The device has two options associated with the HALT mode. The first option enables the HALT mode feature, while the second option disables the HALT mode selected through bit 0 of the ECON register. With the HALT mode enable option, the device will enter and exit the HALT mode as described above. With the HALT disable option, the device cannot be placed in the HALT mode (writing a “1” to the HALT flag will have no effect, the HALT flag will remain “0”).

The WATCHDOG detector circuit is inhibited during the HALT mode. However, the clock monitor circuit if enabled remains active during HALT mode in order to ensure a clock monitor error if the device inadvertently enters the HALT mode as a result of a runaway program or power glitch.

If the device is placed in the HALT mode, with the R/C oscillator selected, the clock input pin (CKI) is forced to a logic high internally. With the crystal or external oscillator the CKI pin is TRI-STATE.

8.0 Power Save Modes (Continued)

8.3 MULTI-INPUT WAKEUP

The Multi-Input Wakeup feature is used to return (wakeup) the device from either the HALT or IDLE modes. Alternately Multi-Input Wakeup/Interrupt feature may also be used to generate up to 8 edge selectable external interrupts.

Figure 20 shows the Multi-Input Wakeup logic.

The Multi-Input Wakeup feature utilizes the L Port. The user selects which particular L port bit (or combination of L Port bits) will cause the device to exit the HALT or IDLE modes. The selection is done through the register WKEN. The register WKEN is an 8-bit read/write register, which contains a control bit for every L port bit. Setting a particular WKEN bit enables a Wakeup from the associated L port pin.

The user can select whether the trigger condition on the selected L Port pin is going to be either a positive edge (low to high transition) or a negative edge (high to low transition). This selection is made via the register WKEDG, which is an 8-bit control register with a bit assigned to each L Port pin. Setting the control bit will select the trigger condition to be a negative edge on that particular L Port pin. Resetting the bit selects the trigger condition to be a positive edge. Changing an edge select entails several steps in order to avoid a Wakeup condition as a result of the edge change. First, the associated WKEN bit should be reset, followed by the edge select change in WKEDG. Next, the associated WKPND bit should be cleared, followed by the associated WKEN bit being re-enabled.

An example may serve to clarify this procedure. Suppose we wish to change the edge select from positive (low going high) to negative (high going low) for L Port bit 5, where bit 5 has previously been enabled for an input interrupt. The program would be as follows:

```

RBIT 5, WKEN ; Disable MIWU
SBIT 5, WKEDG ; Change edge polarity
RBIT 5, WKPND ; Reset pending flag
SBIT 5, WKEN ; Enable MIWU
  
```

If the L port bits have been used as outputs and then changed to inputs with Multi-Input Wakeup/Interrupt, a safety procedure should also be followed to avoid wakeup conditions. After the selected L port bits have been changed from output to input but before the associated WKEN bits are enabled, the associated edge select bits in WKEDG should be set or reset for the desired edge selects, followed by the associated WKPND bits being cleared.

This same procedure should be used following reset, since the L port inputs are left floating as a result of reset.

The occurrence of the selected trigger condition for Multi-Input Wakeup is latched into a pending register called WKPND. The respective bits of the WKPND register will be set on the occurrence of the selected trigger edge on the corresponding Port L pin. The user has the responsibility of clearing these pending flags. Since WKPND is a pending register for the occurrence of selected wakeup conditions, the device will not enter the HALT mode if any Wakeup bit is both enabled and pending. Consequently, the user must clear the pending flags before attempting to enter the HALT mode.

WKEN and WKEDG are all read/write registers, and are cleared at reset. WKPND register contains random value after reset.

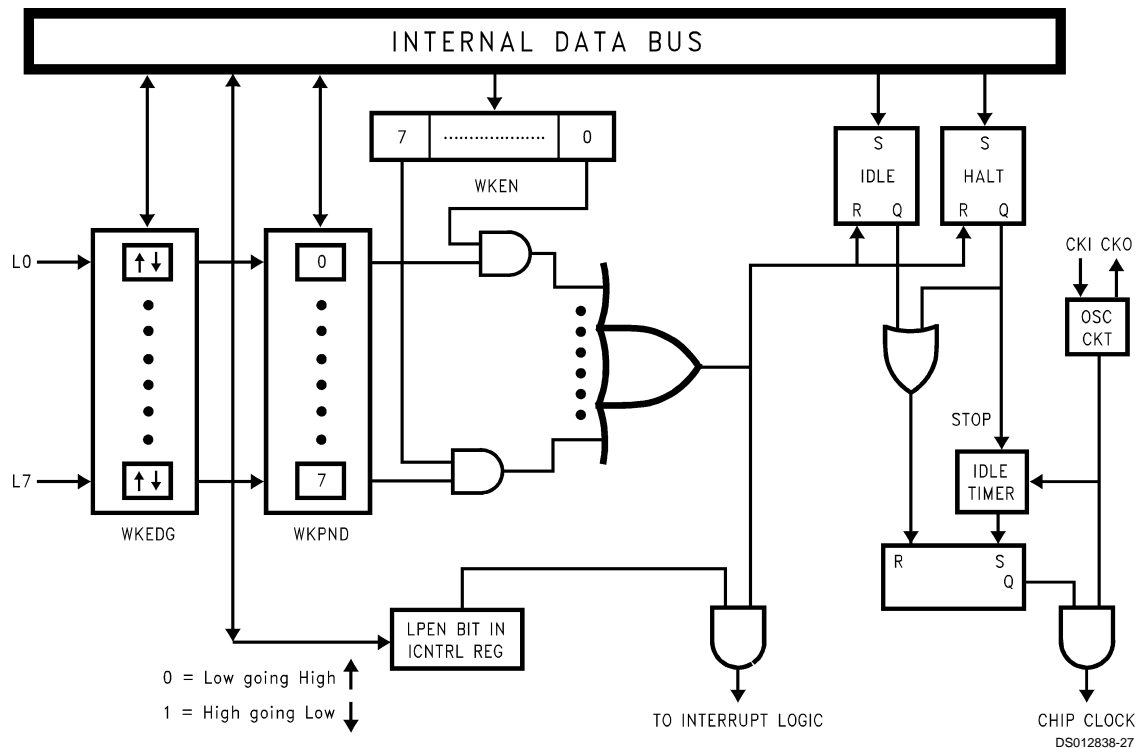

FIGURE 20. Multi-Input Wake Up Logic

9.0 Interrupts

9.1 INTRODUCTION

The device supports eight vectored interrupts. Interrupt sources include Timer 1, Timer T0, Port L Wakeup, Software Trap, MICROWIRE/PLUS, and External Input.

All interrupts force a branch to location 00FF Hex in program memory. The VIS instruction may be used to vector to the appropriate service routine from location 00FF Hex.

The Software trap has the highest priority while the default VIS has the lowest priority.

Each of the six maskable inputs has a fixed arbitration ranking and vector.

Figure 21 shows the Interrupt Block Diagram.

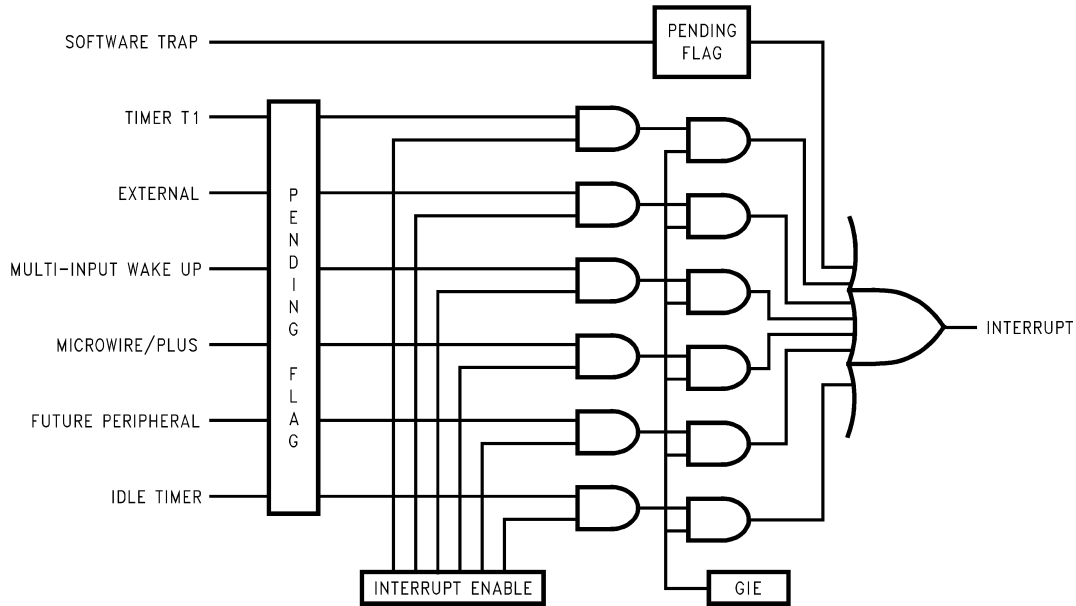

DS012838-28

FIGURE 21. Interrupt Block Diagram

9.0 Interrupts (Continued)

9.2 MASKABLE INTERRUPTS

All interrupts other than the Software Trap are maskable. Each maskable interrupt has an associated enable bit and pending flag bit. The pending bit is set to 1 when the interrupt condition occurs. The state of the interrupt enable bit, combined with the GIE bit determines whether an active pending flag actually triggers an interrupt. All of the maskable interrupt pending and enable bits are contained in mapped control registers, and thus can be controlled by the software.

A maskable interrupt condition triggers an interrupt under the following conditions:

1. The enable bit associated with that interrupt is set.
2. The GIE bit is set.
3. The device is not processing a non-maskable interrupt. (If a non-maskable interrupt is being serviced, a maskable interrupt must wait until that service routine is completed.)

An interrupt is triggered only when all of these conditions are met at the beginning of an instruction. If different maskable interrupts meet these conditions simultaneously, the highest priority interrupt will be serviced first, and the other pending interrupts must wait.

Upon Reset, all pending bits, individual enable bits, and the GIE bit are reset to zero. Thus, a maskable interrupt condition cannot trigger an interrupt until the program enables it by setting both the GIE bit and the individual enable bit. When enabling an interrupt, the user should consider whether or not a previously activated (set) pending bit should be acknowledged. If, at the time an interrupt is enabled, any previous occurrences of the interrupt should be ignored, the associated pending bit must be reset to zero prior to enabling the interrupt. Otherwise, the interrupt may be simply enabled; if the pending bit is already set, it will immediately trigger an interrupt. A maskable interrupt is active if its associated enable and pending bits are set.

An interrupt is an asynchronous event which may occur before, during, or after an instruction cycle. Any interrupt which occurs during the execution of an instruction is not acknowledged until the start of the next normally executed instruction is to be skipped, the skip is performed before the pending interrupt is acknowledged.

At the start of interrupt acknowledgment, the following actions occur:

1. The GIE bit is automatically reset to zero, preventing any subsequent maskable interrupt from interrupting the current service routine. This feature prevents one maskable interrupt from interrupting another one being serviced.
2. The address of the instruction about to be executed is pushed onto the stack.
3. The program counter (PC) is loaded with 00FF Hex, causing a jump to that program memory location.

The device requires seven instruction cycles to perform the actions listed above.

If the user wishes to allow nested interrupts, the interrupts service routine may set the GIE bit to 1 by writing to the PSW register, and thus allow other maskable interrupts to interrupt the current service routine. If nested interrupts are allowed, caution must be exercised. The user must write the program in such a way as to prevent stack overflow, loss of saved context information, and other unwanted conditions.

The interrupt service routine stored at location 00FF Hex should use the VIS instruction to determine the cause of the

interrupt, and jump to the interrupt handling routine corresponding to the highest priority enabled and active interrupt. Alternately, the user may choose to poll all interrupt pending and enable bits to determine the source(s) of the interrupt. If more than one interrupt is active, the user's program must decide which interrupt to service.

Within a specific interrupt service routine, the associated pending bit should be cleared. This is typically done as early as possible in the service routine in order to avoid missing the next occurrence of the same type of interrupt event. Thus, if the same event occurs a second time, even while the first occurrence is still being serviced, the second occurrence will be serviced immediately upon return from the current interrupt routine.

An interrupt service routine typically ends with an RETI instruction. This instruction sets the GIE bit back to 1, pops the address stored on the stack, and restores that address to the program counter. Program execution then proceeds with the next instruction that would have been executed had there been no interrupt. If there are any valid interrupts pending, the highest-priority interrupt is serviced immediately upon return from the previous interrupt.

9.3 VIS INSTRUCTION

The general interrupt service routine, which starts at address 00FF Hex, must be capable of handling all types of interrupts. The VIS instruction, together with an interrupt vector table, directs the device to the specific interrupt handling routine based on the cause of the interrupt.

VIS is a single-byte instruction, typically used at the very beginning of the general interrupt service routine at address 00FF Hex, or shortly after that point, just after the code used for context switching. The VIS instruction determines which enabled and pending interrupt has the highest priority, and causes an indirect jump to the address corresponding to that interrupt source. The jump addresses (vectors) for all possible interrupts sources are stored in a vector table.

The vector table may be as long as 32 bytes (maximum of 16 vectors) and resides at the top of the 256-byte block containing the VIS instruction. However, if the VIS instruction is at the very top of a 256-byte block (such as at 00FF Hex), the vector table resides at the top of the next 256-byte block. Thus, if the VIS instruction is located somewhere between 00FF and 01DF Hex (the usual case), the vector table is located between addresses 01E0 and 01FF Hex. If the VIS instruction is located between 01FF and 02DF Hex, then the vector table is located between addresses 02E0 and 02FF Hex, and so on.

Each vector is 15 bits long and points to the beginning of a specific interrupt service routine somewhere in the 32 kbyte memory space. Each vector occupies two bytes of the vector table, with the higher-order byte at the lower address. The vectors are arranged in order of interrupt priority. The vector of the maskable interrupt with the lowest rank is located at 0yE0 (higher-order byte) and 0yE1 (lower-order byte). The next priority interrupt is located at 0yE2 and 0yE3, and so forth in increasing rank. The Software Trap has the highest rank and its vector is always located at 0yFE and 0yFF. The number of interrupts which can become active defines the size of the table.

Table 5 shows the types of interrupts, the interrupt arbitration ranking, and the locations of the corresponding vectors in the vector table.

The vector table should be filled by the user with the memory locations of the specific interrupt service routines. For ex-

9.0 Interrupts (Continued)

ample, if the Software Trap routine is located at 0310 Hex, then the vector location 0yFE and -0yFF should contain the data 03 and 10 Hex, respectively. When a Software Trap interrupt occurs and the VIS instruction is executed, the program jumps to the address specified in the vector table.

The interrupt sources in the vector table are listed in order of rank, from highest to lowest priority. If two or more enabled and pending interrupts are detected at the same time, the one with the highest priority is serviced first. Upon return from the interrupt service routine, the next highest-level pending interrupt is serviced.

If the VIS instruction is executed, but no interrupts are enabled and pending, the lowest-priority interrupt vector is used, and a jump is made to the corresponding address in the vector table. This is an unusual occurrence, and may be the result of an error. It can legitimately result from a change in the enable bits or pending flags prior to the execution of the VIS instruction, such as executing a single cycle instruction which clears an enable flag at the same time that the pending flag is set. It can also result, however, from inadvertent execution of the VIS command outside of the context of an interrupt.

The default VIS interrupt vector can be useful for applications in which time critical interrupts can occur during the servicing of another interrupt. Rather than restoring the pro-

gram context (A, B, X, etc.) and executing the RETI instruction, an interrupt service routine can be terminated by returning to the VIS instruction. In this case, interrupts will be serviced in turn until no further interrupts are pending and the default VIS routine is started. After testing the GIE bit to ensure that execution is not erroneous, the routine should restore the program context and execute the RETI to return to the interrupted program.

This technique can save up to fifty instruction cycles (t_c), or more, (50 μ s at 10 MHz oscillator) of latency for pending interrupts with a penalty of fewer than ten instruction cycles if no further interrupts are pending.

To ensure reliable operation, the user should always use the VIS instruction to determine the source of an interrupt. Although it is possible to poll the pending bits to detect the source of an interrupt, this practice is not recommended. The use of polling allows the standard arbitration ranking to be altered, but the reliability of the interrupt system is compromised. The polling routine must individually test the enable and pending bits of each maskable interrupt. If a Software Trap interrupt should occur, it will be serviced last, even though it should have the highest priority. Under certain conditions, a Software Trap could be triggered but not serviced, resulting in an inadvertent "locking out" of all maskable interrupts by the Software Trap pending flag. Problems such as this can be avoided by using VIS instruction.

TABLE 5. Interrupt Vector Table

Arbitration Ranking	Source	Description	Vector (Note 20) Address (Hi-Low Byte)
(1) Highest	Software	INTR Instruction	0yFE–0yFF
(2)	Reserved	Future	0yFC–0yFD
(3)	External	G0	0yFA–0yFB
(4)	Timer T0	Underflow	0yF8–0yF9
(5)	Timer T1	T1A/Underflow	0yF6–0yF7
(6)	Timer T1	T1B	0yF4–0yF5
(7)	MICROWIRE/PLUS	BUSY Low	0yF2–0yF3
(8)	Reserved	Future	0yF0–0yF1
(9)	Reserved	Future	0yEE–0yEF
(10)	Reserved	Future	0yEC–0yED
(11)	Reserved	Future	0yEA–0yEB
(12)	Reserved	Future	0yE8–0yE9
(13)	Reserved	Future	0yE6–0yE7
(14)	Reserved	Future	0yE4–0yE5
(15)	Port L/Wakeup	Port L Edge	0yE2–0yE3
(16) Lowest	Default	VIS Instruction Execution without any interrupts	0yE0–0yE1

Note 20: y is a variable which represents the VIS block. VIS and the vector table must be located in the same 256-byte block except if VIS is located at the last address of a block. In this case, the table must be in the next block.

9.0 Interrupts (Continued)

9.3.1 VIS Execution

When the VIS instruction is executed it activates the arbitration logic. The arbitration logic generates an even number between E0 and FE (E0, E2, E4, E6 etc...) depending on which active interrupt has the highest arbitration ranking at the time of the 1st cycle of VIS is executed. For example, if the software trap interrupt is active, FE is generated. If the external interrupt is active and the software trap interrupt is not, then FA is generated and so forth. If the only active interrupt is software trap, than E0 is generated. This number replaces the lower byte of the PC. The upper byte of the PC

remains unchanged. The new PC is therefore pointing to the vector of the active interrupt with the highest arbitration ranking. This vector is read from program memory and placed into the PC which is now pointed to the 1st instruction of the service routine of the active interrupt with the highest arbitration ranking.

Figure 22 illustrates the different steps performed by the VIS instruction. Figure 23 shows a flowchart for the VIS instruction.

The non-maskable interrupt pending flag is cleared by the RPND (Reset Non-Maskable Pending Bit) instruction (under certain conditions) and upon RESET.

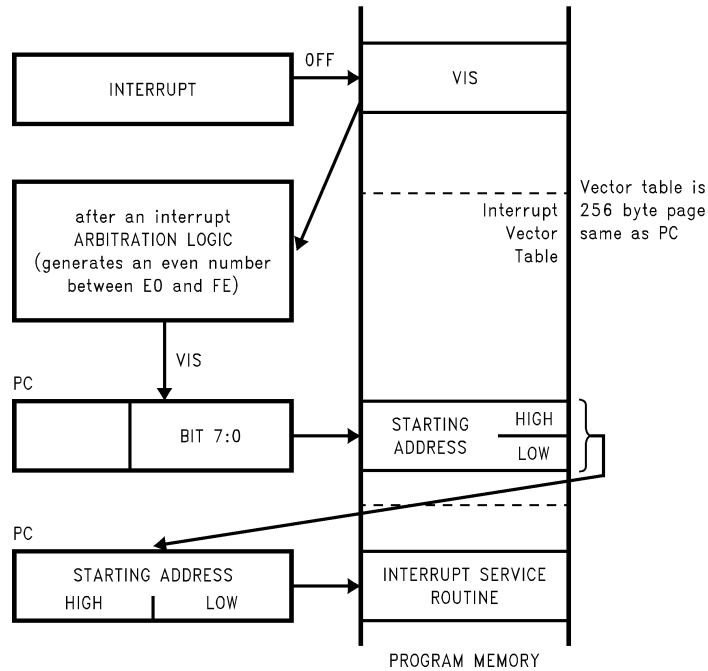
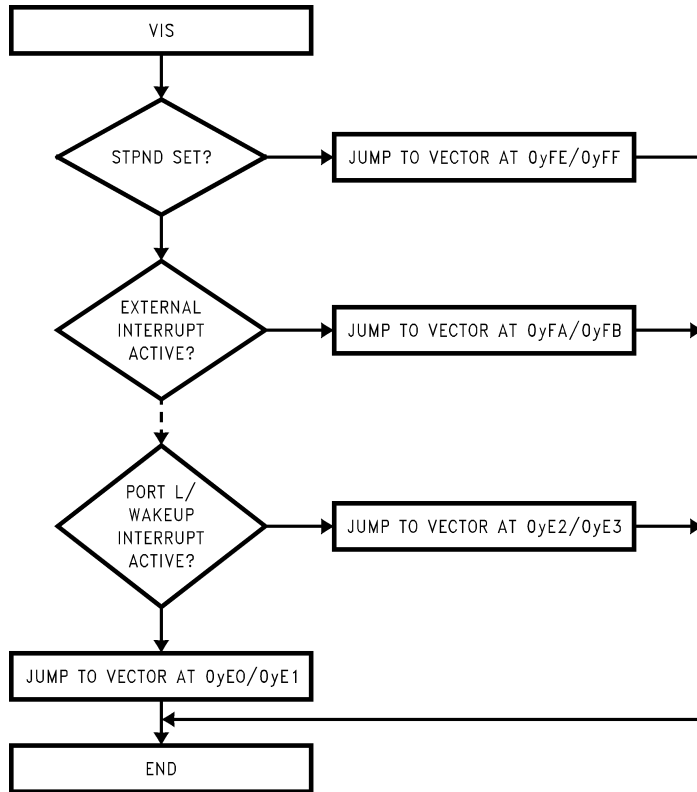

FIGURE 22. VIS Operation

9.0 Interrupts (Continued)



DS012838-30

FIGURE 23. VIS Flowchart

9.0 Interrupts (Continued)

Programming Example: External Interrupt

```

        PSW                =00EF
        CNTRL              =00EE
        RBIT               0,PORTGC
        RBIT               0,PORTGD      ; G0 pin configured Hi-Z
        SBIT               IEDG, CNTRL   ; Ext interrupt polarity; falling edge
        SBIT               GIE, PSW     ; Set the GIE bit
        SBIT               EXEN, PSW    ; Enable the external interrupt
WAIT:   JP                WAIT         ; Wait for external interrupt
        .
        .
        .
        .=0FF              ; The interrupt causes a
        VIS                ; branch to address 0FF
                          ;The VIS causes a branch to
                          ;interrupt vector table
        .
        .
        .
        .=01FA             ; Vector table (within 256 byte
        .ADDRW SERVICE     ; of VIS inst.) containing the ext
                          ;interrupt service routine
        .
        .
        .
SERVICE:                                ; Interrupt Service Routine
        RBIT, EXPND, PSW    ; Reset ext interrupt pend. bit
        .
        .
        .
        RET                ; Return, set the GIE bit

```

9.0 Interrupts (Continued)

9.4 NON-MASKABLE INTERRUPT

9.4.1 Pending Flag

There is a pending flag bit associated with the non-maskable interrupt, called STPND. This pending flag is not memory-mapped and cannot be accessed directly by the software.

The pending flag is reset to zero when a device Reset occurs. When the non-maskable interrupt occurs, the associated pending bit is set to 1. The interrupt service routine should contain an RPND instruction to reset the pending flag to zero. The RPND instruction always resets the STPND flag.

9.4.2 Software Trap

The Software Trap is a special kind of non-maskable interrupt which occurs when the INTR instruction (used to acknowledge interrupts) is fetched from program memory and placed in the instruction register. This can happen in a variety of ways, usually because of an error condition. Some examples of causes are listed below.

If the program counter incorrectly points to a memory location beyond the available program memory space, the non-existent or unused memory location returns zeroes which is interpreted as the INTR instruction.

If the stack is popped beyond the allowed limit (address 02F or 06F Hex), a Software Trap is triggered.

A Software Trap can be triggered by a temporary hardware condition such as a brownout or power supply glitch.

The Software Trap has the highest priority of all interrupts. When a Software Trap occurs, the STPND bit is set. The GIE bit is not affected and the pending bit (not accessible by the user) is used to inhibit other interrupts and to direct the program to the ST service routine with the VIS instruction. Nothing can interrupt a Software Trap service routine except for another Software Trap. The STPND can be reset only by the RPND instruction or a chip Reset.

The Software Trap indicates an unusual or unknown error condition. Generally, returning to normal execution at the point where the Software Trap occurred cannot be done reliably. Therefore, the Software Trap service routine should reinitialize the stack pointer and perform a recovery procedure that restarts the software at some known point, similar to a device Reset, but not necessarily performing all the same functions as a device Reset. The routine must also execute the RPND instruction to reset the STPND flag. Otherwise, all other interrupts will be locked out. To the extent possible, the interrupt routine should record or indicate the context of the device so that the cause of the Software Trap can be determined.

If the user wishes to return to normal execution from the point at which the Software Trap was triggered, the user must first execute RPND, followed by RETSK rather than RETI or RET. This is because the return address stored on the stack is the address of the INTR instruction that triggered the interrupt. The program must skip that instruction in order to proceed with the next one. Otherwise, an infinite loop of Software Traps and returns will occur.

Programming a return to normal execution requires careful consideration. If the Software Trap routine is interrupted by another Software Trap, the RPND instruction in the service routine for the second Software Trap will reset the STPND flag; upon return to the first Software Trap routine, the STPND flag will have the wrong state. This will allow maskable interrupts to be acknowledged during the servicing of the first Software Trap. To avoid problems such as this, the user program should contain the Software Trap routine to perform a recovery procedure rather than a return to normal execution.

Under normal conditions, the STPND flag is reset by a RPND instruction in the Software Trap service routine. If a programming error or hardware condition (brownout, power supply glitch, etc.) sets the STPND flag without providing a way for it to be cleared, all other interrupts will be locked out. To alleviate this condition, the user can use extra RPND instructions in the main program and in the WATCHDOG service routine (if present). There is no harm in executing extra RPND instructions in these parts of the program.

9.5 PORT L INTERRUPTS

Port L provides the user with an additional eight fully selectable, edge sensitive interrupts which are all vectored into the same service subroutine.

The interrupt from Port L shares logic with the wake up circuitry. The register WKEN allows interrupts from Port L to be individually enabled or disabled. The register WKEDG specifies the trigger condition to be either a positive or a negative edge. Finally, the register WKPND latches in the pending trigger conditions.

The GIE (Global Interrupt Enable) bit enables the interrupt function.

A control flag, LPEN, functions as a global interrupt enable for Port L interrupts. Setting the LPEN flag will enable interrupts and vice versa. A separate global pending flag is not needed since the register WKPND is adequate.

Since Port L is also used for waking the device out of the HALT or IDLE modes, the user can elect to exit the HALT or IDLE modes either with or without the interrupt enabled. If he elects to disable the interrupt, then the device will restart execution from the instruction immediately following the instruction that placed the microcontroller in the HALT or IDLE modes. In the other case, the device will first execute the interrupt service routine and then revert to normal operation. (See HALT MODE for clock option wakeup information.)

9.6 INTERRUPT SUMMARY

The device uses the following types of interrupts, listed below in order of priority:

1. The Software Trap non-maskable interrupt, triggered by the INTR (00 opcode) instruction. The Software Trap is acknowledged immediately. This interrupt service routine can be interrupted only by another Software Trap. The Software Trap should end with two RPND instructions followed by a restart procedure.
2. Maskable interrupts, triggered by an on-chip peripheral block or an external device connected to the device. Under ordinary conditions, a maskable interrupt will not interrupt any other interrupt routine in progress. A maskable interrupt routine in progress can be interrupted by the non-maskable interrupt request. A maskable interrupt routine should end with an RETI instruction.

10.0 WATCHDOG/Clock Monitor

The devices contain a user selectable WATCHDOG and clock monitor. The following section is applicable only if WATCHDOG feature has been selected in the ECON register. The WATCHDOG is designed to detect the user program getting stuck in infinite loops resulting in loss of program control or “runaway” programs.

The WATCHDOG logic contains two separate service windows. While the user programmable upper window selects the WATCHDOG service time, the lower window provides protection against an infinite program loop that contains the WATCHDOG service instruction.

The COP8SAx devices provide the added feature of a software trap that provides protection against stack overpops and addressing locations outside valid user program space. The Clock Monitor is used to detect the absence of a clock or a very slow clock below a specified rate on the CKI pin.

The WATCHDOG consists of two independent logic blocks: WD UPPER and WD LOWER. WD UPPER establishes the upper limit on the service window and WD LOWER defines the lower limit of the service window.

Servicing the WATCHDOG consists of writing a specific value to a WATCHDOG Service Register named WDSVR which is memory mapped in the RAM. This value is composed of three fields, consisting of a 2-bit Window Select, a 5-bit Key Data field, and the 1-bit Clock Monitor Select field. *Table 6* shows the WDSVR register.

TABLE 6. WATCHDOG Service Register (WDSVR)

Window Select		Key Data					Clock Monitor
X	X	0	1	1	0	0	Y

The lower limit of the service window is fixed at 256 instruction cycles. Bits 7 and 6 of the WDSVR register allow the user to pick an upper limit of the service window.

Table 7 shows the four possible combinations of lower and upper limits for the WATCHDOG service window. This flexibility in choosing the WATCHDOG service window prevents any undue burden on the user software.

Bits 5, 4, 3, 2 and 1 of the WDSVR register represent the 5-bit Key Data field. The key data is fixed at 01100. Bit 0 of the WDSVR Register is the Clock Monitor Select bit.

TABLE 7. WATCHDOG Service Window Select

WDSVR Bit 7	WDSVR Bit 6	Clock Monitor	Service Window (Lower-Upper Limits)
0	0	x	2048–8k t_C Cycles
0	1	x	2048–16k t_C Cycles
1	0	x	2048–32k t_C Cycles
1	1	x	2048–64k t_C Cycles
x	x	0	Clock Monitor Disabled
x	x	1	Clock Monitor Enabled

10.1 CLOCK MONITOR

The Clock Monitor aboard the device can be selected or deselected under program control. The Clock Monitor is guaranteed not to reject the clock if the instruction cycle clock ($1/t_C$) is greater or equal to 10 kHz. This equates to a clock input rate on CKI of greater or equal to 100 kHz.

10.2 WATCHDOG/CLOCK MONITOR OPERATION

The WATCHDOG is enabled by bit 2 of the ECON register. When this ECON bit is 0, the WATCHDOG is enabled and pin G1 becomes the WATCHDOG output with a weak pullup. The WATCHDOG and Clock Monitor are disabled during reset. The device comes out of reset with the WATCHDOG armed, the WATCHDOG Window Select bits (bits 6, 7 of the WDSVR Register) set, and the Clock Monitor bit (bit 0 of the WDSVR Register) enabled. Thus, a Clock Monitor error will occur after coming out of reset, if the instruction cycle clock frequency has not reached a minimum specified value, including the case where the oscillator fails to start.

The WDSVR register can be written to only once after reset and the key data (bits 5 through 1 of the WDSVR Register) must match to be a valid write. This write to the WDSVR register involves two irrevocable choices: (i) the selection of the WATCHDOG service window (ii) enabling or disabling of the Clock Monitor. Hence, the first write to WDSVR Register involves selecting or deselecting the Clock Monitor, select the WATCHDOG service window and match the WATCHDOG key data. Subsequent writes to the WDSVR register will compare the value being written by the user to the WATCHDOG service window value and the key data (bits 7 through 1) in the WDSVR Register. *Table 8* shows the sequence of events that can occur.

The user must service the WATCHDOG at least once before the upper limit of the service window expires. The WATCHDOG may not be serviced more than once in every lower limit of the service window. The user may service the WATCHDOG as many times as wished in the time period between the lower and upper limits of the service window. The first write to the WDSVR Register is also counted as a WATCHDOG service.

The WATCHDOG has an output pin associated with it. This is the WDOUT pin, on pin 1 of the port G. WDOUT is active low and must be externally connected to the RESET pin or to some other external logic which handles WATCHDOG event. The WDOUT pin has a weak pullup in the inactive state. This pull-up is sufficient to serve as the connection to V_{CC} for systems which use the internal Power On Reset. Upon triggering the WATCHDOG, the logic will pull the WDOUT (G1) pin low for an additional $16 t_C$ – $32 t_C$ cycles after the signal level on WDOUT pin goes below the lower Schmitt trigger threshold. After this delay, the device will stop forcing the WDOUT output low. The WATCHDOG service window will restart when the WDOUT pin goes high.

A WATCHDOG service while the WDOUT signal is active will be ignored. The state of the WDOUT pin is not guaranteed on reset, but if it powers up low then the WATCHDOG will time out and WDOUT will go high.

The Clock Monitor forces the G1 pin low upon detecting a clock frequency error. The Clock Monitor error will continue until the clock frequency has reached the minimum specified value, after which the G1 output will go high following $16 t_C$ – $32 t_C$ clock cycles. The Clock Monitor generates a continual Clock Monitor error if the oscillator fails to start, or fails to reach the minimum specified frequency. The specification for the Clock Monitor is as follows:

$1/t_C > 10 \text{ kHz}$ —No clock rejection.

$1/t_C < 10 \text{ Hz}$ —Guaranteed clock rejection.

10.0 WATCHDOG/Clock Monitor (Continued)

TABLE 8. WATCHDOG Service Actions

Key Data	Window Data	Clock Monitor	Action
Match	Match	Match	Valid Service: Restart Service Window
Don't Care	Mismatch	Don't Care	Error: Generate WATCHDOG Output
Mismatch	Don't Care	Don't Care	Error: Generate WATCHDOG Output
Don't Care	Don't Care	Mismatch	Error: Generate WATCHDOG Output

10.3 WATCHDOG AND CLOCK MONITOR SUMMARY

The following salient points regarding the WATCHDOG and CLOCK MONITOR should be noted:

- Both the WATCHDOG and CLOCK MONITOR detector circuits are inhibited during RESET.
- Following RESET, the WATCHDOG and CLOCK MONITOR are both enabled, with the WATCHDOG having the maximum service window selected.
- The WATCHDOG service window and CLOCK MONITOR enable/disable option can only be changed once, during the initial WATCHDOG service following RESET.
- The initial WATCHDOG service must match the key data value in the WATCHDOG Service register WDSVR in order to avoid a WATCHDOG error.
- Subsequent WATCHDOG services must match all three data fields in WDSVR in order to avoid WATCHDOG errors.
- The correct key data value cannot be read from the WATCHDOG Service register WDSVR. Any attempt to read this key data value of 01100 from WDSVR will read as key data value of all 0's.
- The WATCHDOG detector circuit is inhibited during both the HALT and IDLE modes.
- The CLOCK MONITOR detector circuit is active during both the HALT and IDLE modes. Consequently, the device inadvertently entering the HALT mode will be detected as a CLOCK MONITOR error (provided that the CLOCK MONITOR enable option has been selected by the program).
- With the single-pin R/C oscillator option selected and the CLKDLY bit reset, the WATCHDOG service window will resume following HALT mode from where it left off before entering the HALT mode.
- With the crystal oscillator option selected, or with the single-pin R/C oscillator option selected and the CLKDLY bit set, the WATCHDOG service window will be set to its selected value from WDSVR following HALT. Consequently, the WATCHDOG should not be serviced for at least 256 instruction cycles following HALT, but must be serviced within the selected window to avoid a WATCHDOG error.
- The IDLE timer T0 is not initialized with external RESET.
- The user can sync in to the IDLE counter cycle with an IDLE counter (T0) interrupt or by monitoring the TOPND flag. The TOPND flag is set whenever the twelfth bit of the IDLE counter toggles (every 4096 instruction cycles). The user is responsible for resetting the TOPND flag.

- A hardware WATCHDOG service occurs just as the device exits the IDLE mode. Consequently, the WATCHDOG should not be serviced for at least 256 instruction cycles following IDLE, but must be serviced within the selected window to avoid a WATCHDOG error.
- Following RESET, the initial WATCHDOG service (where the service window and the CLOCK MONITOR enable/disable must be selected) may be programmed anywhere within the maximum service window (65,536 instruction cycles) initialized by RESET. Note that this initial WATCHDOG service may be programmed within the initial 256 instruction cycles without causing a WATCHDOG error.
- In order to RESET the device on the occurrence of a WATCH event, the user must connect the WDOUT pin (G1) pin to the RESET external to the device. The weak pull-up on the WDOUT pin is sufficient to provide the RESET connection to V_{CC} for devices which use both Power On Reset and WATCHDOG.

10.4 DETECTION OF ILLEGAL CONDITIONS

The device can detect various illegal conditions resulting from coding errors, transient noise, power supply voltage drops, runaway programs, etc.

Reading of undefined ROM gets zeroes. The opcode for software interrupt is 00. If the program fetches instructions from undefined ROM, this will force a software interrupt, thus signaling that an illegal condition has occurred.

The subroutine stack grows down for each call (jump to subroutine), interrupt, or PUSH, and grows up for each return or POP. The stack pointer is initialized to RAM location 06F Hex during reset. Consequently, if there are more returns than calls, the stack pointer will point to addresses 070 and 071 Hex (which are undefined RAM). Undefined RAM from addresses 070 to 07F (Segment 0), and all other segments (i.e., Segments 4 ... etc.) is read as all 1's, which in turn will cause the program to return to address 7FFF Hex. This is an undefined ROM location and the instruction fetched (all 0's) from this location will generate a software interrupt signaling an illegal condition.

Thus, the chip can detect the following illegal conditions:

1. Executing from undefined ROM
2. Over "POP"ing the stack by having more returns than calls.

When the software interrupt occurs, the user can re-initialize the stack pointer and do a recovery procedure before restarting (this recovery program is probably similar to that following reset, but might not contain the same program initialization procedures). The recovery program should reset the software interrupt pending bit using the RPND instruction.

11.0 MICROWIRE/PLUS

MICROWIRE/PLUS is a serial SPI compatible synchronous communications interface. The MICROWIRE/PLUS capability enables the device to interface with MICROWIRE/PLUS or SPI peripherals (i.e. A/D converters, display drivers, EEPROMs etc.) and with other microcontrollers which support the MICROWIRE/PLUS or SPI interface. It consists of an 8-bit serial shift register (SIO) with serial data input (SI), serial data output (SO) and serial shift clock (SK). *Figure 24* shows a block diagram of the MICROWIRE/PLUS logic.

The shift clock can be selected from either an internal source or an external source. Operating the MICROWIRE/PLUS arrangement with the internal clock source is called the Master mode of operation. Similarly, operating the MICROWIRE/PLUS arrangement with an external shift clock is called the Slave mode of operation.

The CNTRL register is used to configure and control the MICROWIRE/PLUS mode. To use the MICROWIRE/PLUS, the MSEL bit in the CNTRL register is set to one. In the master mode, the SK clock rate is selected by the two bits, SL0 and SL1, in the CNTRL register. *Table 9* details the different clock rates that may be selected.

TABLE 9. MICROWIRE/PLUS Master Mode Clock Select

SL1	SL0	SK Period
0	0	2 x t _C
0	1	4 x t _C
1	x	8 x t _C

Where t_C is the instruction cycle clock

11.1 MICROWIRE/PLUS OPERATION

Setting the BUSY bit in the PSW register causes the MICROWIRE/PLUS to start shifting the data. It gets reset when eight data bits have been shifted. The user may reset the BUSY bit by software to allow less than 8 bits to shift. If enabled, an interrupt is generated when eight data bits have been shifted. The device may enter the MICROWIRE/PLUS mode either as a Master or as a Slave. *Figure 24* shows how two microcontroller devices and several peripherals may be interconnected using the MICROWIRE/PLUS arrangements.

WARNING

The SIO register should only be loaded when the SK clock is in the idle phase. Loading the SIO register while the SK clock is in the active phase, will result in undefined data in the SIO register.

Setting the BUSY flag when the input SK clock is in the active phase while in the MICROWIRE/PLUS is in the slave mode may cause the current SK clock for the SIO shift register to be narrow. For safety, the BUSY flag should only be set when the input SK clock is in the idle phase.

11.1.1 MICROWIRE/PLUS Master Mode Operation

In the MICROWIRE/PLUS Master mode of operation the shift clock (SK) is generated internally. The MICROWIRE/PLUS Master always initiates all data exchanges. The MSEL bit in the CNTRL register must be set to enable the SO and SK functions onto the G Port. The SO and SK pins must also be selected as outputs by setting appropriate bits in the Port G configuration register. In the slave mode, the shift clock stops after 8 clock pulses. *Table 10* summarizes the bit settings required for Master mode of operation.

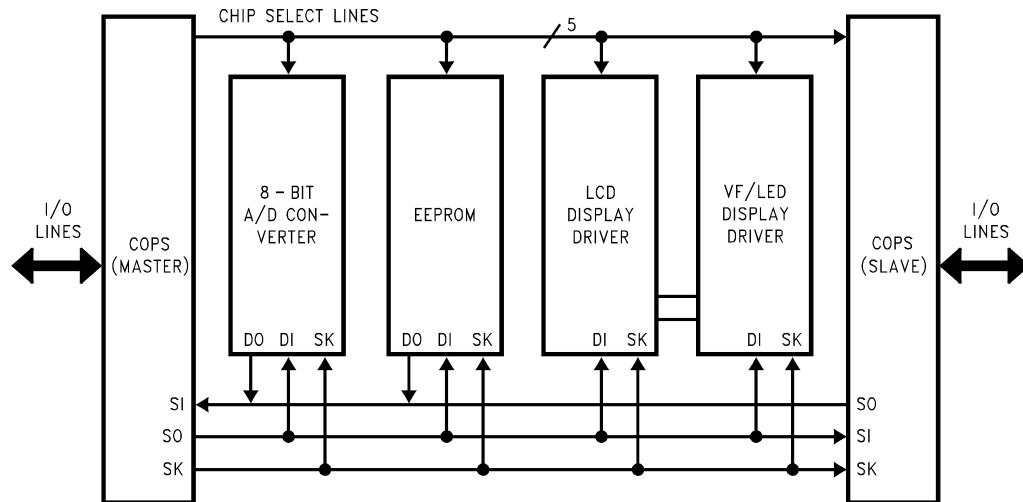

FIGURE 24. MICROWIRE/PLUS Application

DS012838-32

11.0 MICROWIRE/PLUS (Continued)

11.1.2 MICROWIRE/PLUS Slave Mode Operation

In the MICROWIRE/PLUS Slave mode of operation the SK clock is generated by an external source. Setting the MSEL bit in the CNTRL register enables the SO and SK functions onto the G Port. The SK pin must be selected as an input and the SO pin is selected as an output pin by setting and resetting the appropriate bits in the Port G configuration register. *Table 10* summarizes the settings required to enter the Slave mode of operation.

This table assumes that the control flag MSEL is set.

TABLE 10. MICROWIRE/PLUS Mode Settings

G4 (SO) Config. Bit	G5 (SK) Config. Bit	G4 Fun.	G5 Fun.	Operation
1	1	SO	Int. SK	MICROWIRE/PLUS Master
0	1	TRI-STATE	Int. SK	MICROWIRE/PLUS Master
1	0	SO	Ext. SK	MICROWIRE/PLUS Slave
0	0	TRI-STATE	Ext. SK	MICROWIRE/PLUS Slave

The user must set the BUSY flag immediately upon entering the Slave mode. This ensures that all data bits sent by the Master is shifted properly. After eight clock pulses the BUSY flag is clear, the shift clock is stopped, and the sequence may be repeated.

10.1.3 Alternate SK Phase Operation and SK Idle Polarity

The device allows either the normal SK clock or an alternate phase SK clock to shift data in and out of the SIO register. In both the modes the SK idle polarity can be either high or low. The polarity is selected by bit 5 of Port G data register. In the normal mode data is shifted in on the rising edge of the SK clock and the data is shifted out on the falling edge of the SK clock. The SIO register is shifted on each falling edge of the SK clock. In the alternate SK phase operation, data is shifted in on the falling edge of the SK clock and shifted out on the rising edge of the SK clock. Bit 6 of Port G configuration register selects the SK edge.

A control flag, SKSEL, allows either the normal SK clock or the alternate SK clock to be selected. Resetting SKSEL causes the MICROWIRE/PLUS logic to be clocked from the normal SK signal. Setting the SKSEL flag selects the alternate SK clock. The SKSEL is mapped into the G6 configuration bit. The SKSEL flag will power up in the reset condition, selecting the normal SK signal.

TABLE 11. MICROWIRE/PLUS Shift Clock Polarity and Sample/Shift Phase

SK Phase	Port G		SO Clocked Out On:	SI Sampled On:	SK Idle Phase
	G6 (SKSEL) Config. Bit	G5 Data Bit			
Normal	0	0	SK Falling Edge	SK Rising Edge	Low
Alternate	1	0	SK Rising Edge	SK Falling Edge	Low
Alternate	0	1	SK Rising Edge	SK Falling Edge	High
Normal	1	1	SK Falling Edge	SK Rising Edge	High

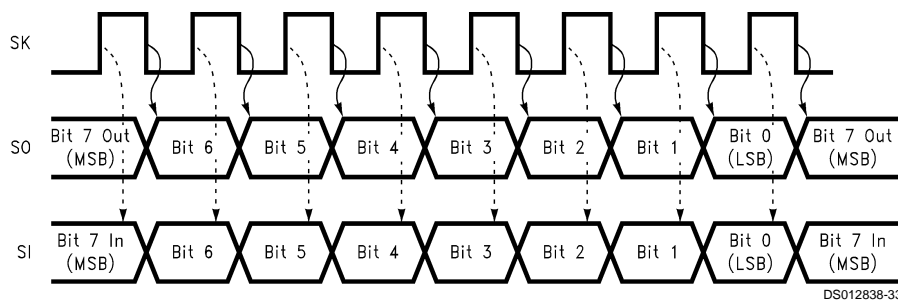

FIGURE 25. MICROWIRE/PLUS SPI Mode Interface Timing, Normal SK Mode, SK Idle Phase being Low

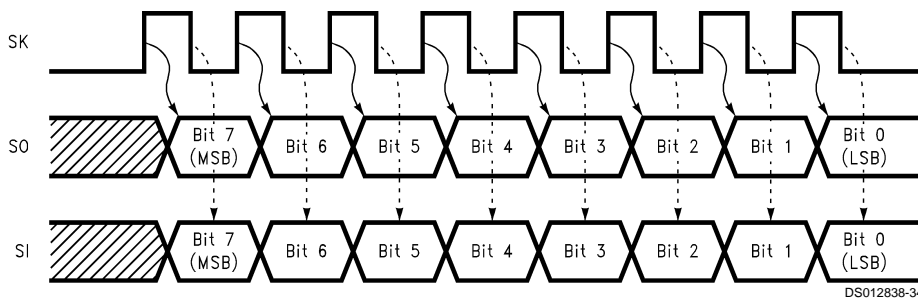

FIGURE 26. MICROWIRE/PLUS SPI Mode Interface Timing, Alternate SK Mode, SK Idle Phase being Low

11.0 MICROWIRE/PLUS (Continued)

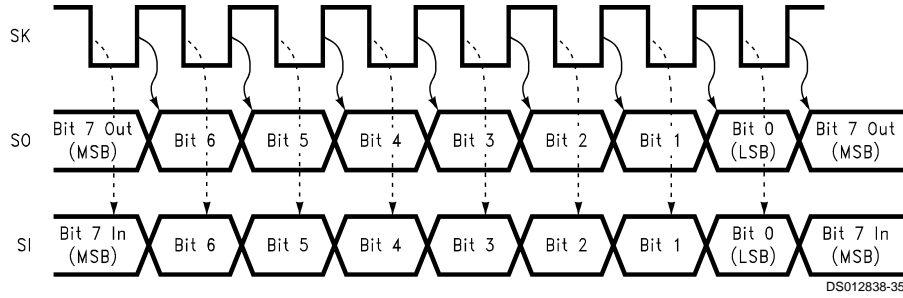

FIGURE 27. MICROWIRE/PLUS SPI Mode Interface Timing, Normal SK Mode, SK Idle Phase being High

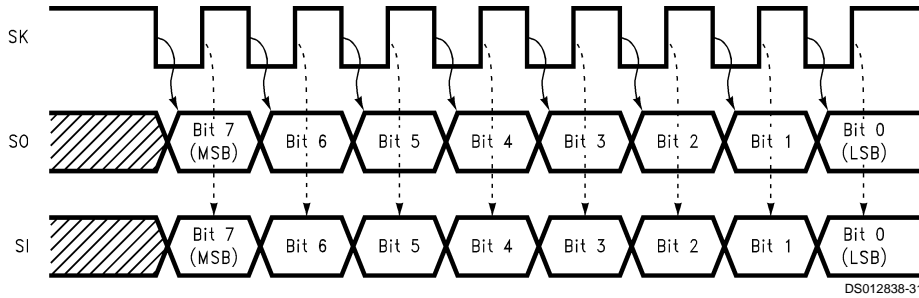

FIGURE 28. MICROWIRE/PLUS SPI Mode Interface Timing, Alternate SK Mode, SK Idle Phase being High

12.0 Memory Map

All RAM, ports and registers (except A and PC) are mapped into data memory address space.

RAM Select	Address ADD REG	Contents
64 On-Chip RAM Bytes. (COP8SAAx)	02 to 2F 30 to 7F	On-Chip RAM (48 Bytes) Unused RAM (Reads as all ones)
128 On-Chip RAM Bytes (COP8SABx/SACx)	00 to 6F 70 to 7F	On-Chip RAM (112 Bytes) Unused RAM (Reads as all ones)
	80 to 93 94 95 96 97	Reserved Port F Data Register Port F Configuration Register Port F Input Pins (Read Only) Reserved
	A0 to C6 C7 C8 C9 CA CB to CF	Reserved WATCHDOG Service Register (Reg: WDSVR) MIWU Edge Select Register (Reg: WKEDG) MIWU Enable Register (Reg: WKEN) MIWU Pending Register (Reg: WKPND) Reserved
	D0 D1 D2 D3 D4 D5 D6 D7 D8 D9 DA DB DC DD to DF	Port L Data Register Port L Configuration Register Port L Input Pins (Read Only) Reserved Port G Data Register Port G Configuration Register Port G Input Pins (Read Only) Reserved Port C Data Register Port C Configuration Register Port C Input Pins (Read Only) Reserved Port D Reserved
	E0 to E5 E6 E7 E8 E9 EA EB EC ED EE EF	Reserved Timer T1 Autoload Register T1RB Lower Byte Timer T1 Autoload Register T1RB Upper Byte ICNTRL Register MICROWIRE/PLUS Shift Register Timer T1 Lower Byte Timer T1 Upper Byte Timer T1 Autoload Register T1RA Lower Byte Timer T1 Autoload Register T1RA Upper Byte CNTRL Control Register PSW Register
	F0 to FB FC FD FE FF	On-Chip RAM Mapped as Registers X Register SP Register B Register Reserved (Segment Register)

Reading any undefined memory location in the address range of 0080H–00FFH will return undefined data.

13.0 Instruction Set

13.1 INTRODUCTION

This section defines the instruction set of the COP8SAx Family members. It contains information about the instruction set features, addressing modes and types.

13.2 INSTRUCTION FEATURES

The strength of the instruction set is based on the following features:

- Mostly single-byte opcode instructions minimize program size.
- One instruction cycle for the majority of single-byte instructions to minimize program execution time.
- Many single-byte, multiple function instructions such as DRSZ.
- Three memory mapped pointers: two for register indirect addressing, and one for the software stack.
- Sixteen memory mapped registers that allow an optimized implementation of certain instructions.
- Ability to set, reset, and test any individual bit in data memory address space, including the memory-mapped I/O ports and registers.
- Register-Indirect LOAD and EXCHANGE instructions with optional automatic post-incrementing or decrementing of the register pointer. This allows for greater efficiency (both in cycle time and program code) in loading, walking across and processing fields in data memory.
- Unique instructions to optimize program size and throughput efficiency. Some of these instructions are DRSZ, IFBNE, DCOR, RETSK, VIS and RRC.

12.3 ADDRESSING MODES

The instruction set offers a variety of methods for specifying memory addresses. Each method is called an addressing mode. These modes are classified into two categories: operand addressing modes and transfer-of-control addressing modes. Operand addressing modes are the various methods of specifying an address for accessing (reading or writing) data. Transfer-of-control addressing modes are used in conjunction with jump instructions to control the execution sequence of the software program.

13.3.1 Operand Addressing Modes

The operand of an instruction specifies what memory location is to be affected by that instruction. Several different operand addressing modes are available, allowing memory locations to be specified in a variety of ways. An instruction can specify an address directly by supplying the specific address, or indirectly by specifying a register pointer. The contents of the register (or in some cases, two registers) point to the desired memory location. In the immediate mode, the data byte to be used is contained in the instruction itself.

Each addressing mode has its own advantages and disadvantages with respect to flexibility, execution speed, and program compactness. Not all modes are available with all instructions. The Load (LD) instruction offers the largest number of addressing modes.

The available addressing modes are:

- Direct

- Register B or X Indirect
- Register B or X Indirect with Post-Incrementing/Decrementing
- Immediate
- Immediate Short
- Indirect from Program Memory

The addressing modes are described below. Each description includes an example of an assembly language instruction using the described addressing mode.

Direct. The memory address is specified directly as a byte in the instruction. In assembly language, the direct address is written as a numerical value (or a label that has been defined elsewhere in the program as a numerical value).

Example: Load Accumulator Memory Direct

```
LD A,05
```

Reg/Data Memory	Contents Before	Contents After
Accumulator	XX Hex	A6 Hex
Memory Location 0005 Hex	A6 Hex	A6 Hex

Register B or X Indirect. The memory address is specified by the contents of the B Register or X register (pointer register). In assembly language, the notation [B] or [X] specifies which register serves as the pointer.

Example: Exchange Memory with Accumulator, B Indirect

```
X A,[B]
```

Reg/Data Memory	Contents Before	Contents After
Accumulator	01 Hex	87 Hex
Memory Location 0005 Hex	87 Hex	01 Hex
B Pointer	05 Hex	05 Hex

Register B or X Indirect with Post-Incrementing/Decrementing. The relevant memory address is specified by the contents of the B Register or X register (pointer register). The pointer register is automatically incremented or decremented after execution, allowing easy manipulation of memory blocks with software loops. In assembly language, the notation [B+], [B-], [X+], or [X-] specifies which register serves as the pointer, and whether the pointer is to be incremented or decremented.

Example: Exchange Memory with Accumulator, B Indirect with Post-Increment

```
X A,[B+]
```

Reg/Data Memory	Contents Before	Contents After
Accumulator	03 Hex	62 Hex
Memory Location 0005 Hex	62 Hex	03 Hex
B Pointer	05 Hex	06 Hex

Intermediate. The data for the operation follows the instruction opcode in program memory. In assembly language, the number sign character (#) indicates an immediate operand.

13.0 Instruction Set (Continued)

Example: Load Accumulator Immediate

LD A,#05

Reg/Data	Contents	Contents
Memory	Before	After
Accumulator	XX Hex	05 Hex

Immediate Short. This is a special case of an immediate instruction. In the “Load B immediate” instruction, the 4-bit immediate value in the instruction is loaded into the lower nibble of the B register. The upper nibble of the B register is reset to 0000 binary.

Example: Load B Register Immediate Short

LD B,#7

Reg/Data	Contents	Contents
Memory	Before	After
B Pointer	12 Hex	07 Hex

Indirect from Program Memory. This is a special case of an indirect instruction that allows access to data tables stored in program memory. In the “Load Accumulator Indirect” (LAID) instruction, the upper and lower bytes of the Program Counter (PCU and PCL) are used temporarily as a pointer to program memory. For purposes of accessing program memory, the contents of the Accumulator and PCL are exchanged. The data pointed to by the Program Counter is loaded into the Accumulator, and simultaneously, the original contents of PCL are restored so that the program can resume normal execution.

Example: Load Accumulator Indirect

LAID

Reg/Data	Contents	Contents
Memory	Before	After
PCU	04 Hex	04 Hex
PCL	35 Hex	36 Hex
Accumulator	1F Hex	25 Hex
Memory Location 041F Hex	25 Hex	25 Hex

13.3.2 Transfer-of-Control Addressing Modes

Program instructions are usually executed in sequential order. However, Jump instructions can be used to change the normal execution sequence. Several transfer-of-control addressing modes are available to specify jump addresses.

A change in program flow requires a non-incremental change in the Program Counter contents. The Program Counter consists of two bytes, designated the upper byte (PCU) and lower byte (PCL). The most significant bit of PCU is not used, leaving 15 bits to address the program memory.

Different addressing modes are used to specify the new address for the Program Counter. The choice of addressing mode depends primarily on the distance of the jump. Farther jumps sometimes require more instruction bytes in order to completely specify the new Program Counter contents.

The available transfer-of-control addressing modes are:

- Jump Relative
- Jump Absolute
- Jump Absolute Long
- Jump Indirect

The transfer-of-control addressing modes are described below. Each description includes an example of a Jump instruction using a particular addressing mode, and the effect on the Program Counter bytes of executing that instruction.

Jump Relative. In this 1-byte instruction, six bits of the instruction opcode specify the distance of the jump from the current program memory location. The distance of the jump can range from –31 to +32. A JP+1 instruction is not allowed. The programmer should use a NOP instead.

Example: Jump Relative

JP 0A

Reg	Contents	Contents
	Before	After
PCU	02 Hex	02 Hex
PCL	05 Hex	0F Hex

Jump Absolute. In this 2-byte instruction, 12 bits of the instruction opcode specify the new contents of the Program Counter. The upper three bits of the Program Counter remain unchanged, restricting the new Program Counter address to the same 4 kbyte address space as the current instruction.

(This restriction is relevant only in devices using more than one 4 kbyte program memory space.)

Example: Jump Absolute

JMP 0125

Reg	Contents	Contents
	Before	After
PCU	0C Hex	01 Hex
PCL	77 Hex	25 Hex

Jump Absolute Long. In this 3-byte instruction, 15 bits of the instruction opcode specify the new contents of the Program Counter.

Example: Jump Absolute Long

JMP 03625

Reg/ Memory	Contents	Contents
	Before	After
PCU	42 Hex	36 Hex
PCL	36 Hex	25 Hex

13.0 Instruction Set (Continued)

Jump Indirect. In this 1-byte instruction, the lower byte of the jump address is obtained from a table stored in program memory, with the Accumulator serving as the low order byte of a pointer into program memory. For purposes of accessing program memory, the contents of the Accumulator are written to PCL (temporarily). The data pointed to by the Program Counter (PCH/PCL) is loaded into PCL, while PCH remains unchanged.

Example: Jump Indirect
JID

Reg/ Memory	Contents Before	Contents After
PCU	01 Hex	01 Hex
PCL	C4 Hex	32 Hex
Accumulator Memory Location 0126 Hex	26 Hex	26 Hex
	32 Hex	32 Hex

The VIS instruction is a special case of the Indirect Transfer of Control addressing mode, where the double-byte vector associated with the interrupt is transferred from adjacent addresses in program memory into the Program Counter in order to jump to the associated interrupt service routine.

13.4 INSTRUCTION TYPES

The instruction set contains a wide variety of instructions. The available instructions are listed below, organized into related groups.

Some instructions test a condition and skip the next instruction if the condition is not true. Skipped instructions are executed as no-operation (NOP) instructions.

13.4.1 Arithmetic Instructions

The arithmetic instructions perform binary arithmetic such as addition and subtraction, with or without the Carry bit.

- Add (ADD)
- Add with Carry (ADC)
- Subtract (SUB)
- Subtract with Carry (SUBC)
- Increment (INC)
- Decrement (DEC)
- Decimal Correct (DCOR)
- Clear Accumulator (CLR)
- Set Carry (SC)
- Reset Carry (RC)

13.4.2 Transfer-of-Control Instructions

The transfer-of-control instructions change the usual sequential program flow by altering the contents of the Program Counter. The Jump to Subroutine instructions save the Program Counter contents on the stack before jumping; the Return instructions pop the top of the stack back into the Program Counter.

- Jump Relative (JP)
- Jump Absolute (JMP)
- Jump Absolute Long (JMPL)
- Jump Indirect (JID)
- Jump to Subroutine (JSR)

- Jump to Subroutine Long (JSRL)
- Return from Subroutine (RET)
- Return from Subroutine and Skip (RETSK)
- Return from Interrupt (RETI)
- Software Trap Interrupt (INTR)
- Vector Interrupt Select (VIS)

13.4.3 Load and Exchange Instructions

The load and exchange instructions write byte values in registers or memory. The addressing mode determines the source of the data.

- Load (LD)
- Load Accumulator Indirect (LAID)
- Exchange (X)

13.4.4 Logical Instructions

The logical instructions perform the operations AND, OR, and XOR (Exclusive OR). Other logical operations can be performed by combining these basic operations. For example, complementing is accomplished by exclusiveORing the Accumulator with FF Hex.

- Logical AND (AND)
- Logical OR (OR)
- Exclusive OR (XOR)

13.4.5 Accumulator Bit Manipulation Instructions

The Accumulator bit manipulation instructions allow the user to shift the Accumulator bits and to swap its two nibbles.

- Rotate Right Through Carry (RRC)
- Rotate Left Through Carry (RLC)
- Swap Nibbles of Accumulator (SWAP)

13.4.6 Stack Control Instructions

- Push Data onto Stack (PUSH)
- Pop Data off of Stack (POP)

13.4.7 Memory Bit Manipulation Instructions

The memory bit manipulation instructions allow the user to set and reset individual bits in memory.

- Set Bit (SBIT)
- Reset Bit (RBIT)
- Reset Pending Bit (RPND)

13.4.8 Conditional Instructions

The conditional instruction test a condition. If the condition is true, the next instruction is executed in the normal manner; if the condition is false, the next instruction is skipped.

- If Equal (IFEQ)
- If Not Equal (IFNE)
- If Greater Than (IFGT)
- If Carry (IFC)
- If Not Carry (IFNC)
- If Bit (IFBIT)
- If B Pointer Not Equal (IFBNE)
- And Skip if Zero (ANDSZ)
- Decrement Register and Skip if Zero (DRSZ)

13.0 Instruction Set (Continued)

13.4.9 No-Operation Instruction

The no-operation instruction does nothing, except to occupy space in the program memory and time in execution.

No-Operation (NOP)

Note: The VIS is a special case of the Indirect Transfer of Control addressing mode, where the double byte vector associated with the interrupt is transferred from adjacent addresses in the program memory into the program counter (PC) in order to jump to the associated interrupt service routine.

13.5 REGISTER AND SYMBOL DEFINITION

The following abbreviations represent the nomenclature used in the instruction description and the COP8 cross-assembler.

Registers	
A	8-Bit Accumulator Register
B	8-Bit Address Register
X	8-Bit Address Register
SP	8-Bit Stack Pointer Register
PC	15-Bit Program Counter Register
PU	Upper 7 Bits of PC
PL	Lower 8 Bits of PC
C	1 Bit of PSW Register for Carry
HC	1 Bit of PSW Register for Half Carry
GIE	1 Bit of PSW Register for Global Interrupt Enable
VU	Interrupt Vector Upper Byte
VL	Interrupt Vector Lower Byte

Symbols	
[B]	Memory Indirectly Addressed by B Register
[X]	Memory Indirectly Addressed by X Register
MD	Direct Addressed Memory
Mem	Direct Addressed Memory or [B]
Meml	Direct Addressed Memory or [B] or Immediate Data
Imm	8-Bit Immediate Data
Reg	Register Memory: Addresses F0 to FF (Includes B, X and SP)
Bit	Bit Number (0 to 7)
←	Loaded with
↔	Exchanged with

13.0 Instruction Set (Continued)

13.6 INSTRUCTION SET SUMMARY

ADD	A,Meml	ADD	$A \leftarrow A + \text{Meml}$
ADC	A,Meml	ADD with Carry	$A \leftarrow A + \text{Meml} + C$, $C \leftarrow \text{Carry}$, $\text{HC} \leftarrow \text{Half Carry}$
SUBC	A,Meml	Subtract with Carry	$A \leftarrow A - \overline{\text{Meml}} + C$, $C \leftarrow \text{Carry}$, $\text{HC} \leftarrow \text{Half Carry}$
AND	A,Meml	Logical AND	$A \leftarrow A \text{ and } \overline{\text{Meml}}$
ANDSZ	A,Imm	Logical AND Immed., Skip if Zero	Skip next if $(A \text{ and } \text{Imm}) = 0$
OR	A,Meml	Logical OR	$A \leftarrow A \text{ or } \text{Meml}$
XOR	A,Meml	Logical EXclusive OR	$A \leftarrow A \text{ xor } \text{Meml}$
IFEQ	MD,Imm	IF Equal	Compare MD and Imm, Do next if $\text{MD} = \text{Imm}$
IFEQ	A,Meml	IF Equal	Compare A and Meml, Do next if $A = \text{Meml}$
IFNE	A,Meml	IF Not Equal	Compare A and Meml, Do next if $A \neq \text{Meml}$
IFGT	A,Meml	IF Greater Than	Compare A and Meml, Do next if $A > \text{Meml}$
IFBNE	#	If B Not Equal	Do next if lower 4 bits of $B \neq \text{Imm}$
DRSZ	Reg	Decrement Reg., Skip if Zero	$\text{Reg} \leftarrow \text{Reg} - 1$, Skip if $\text{Reg} = 0$
SBIT	#,Mem	Set BIT	1 to bit, Mem (bit = 0 to 7 immediate)
RBIT	#,Mem	Reset BIT	0 to bit, Mem
IFBIT	#,Mem	IF BIT	If bit #, A or Mem is true do next instruction
RPND		Reset PeNDing Flag	Reset Software Interrupt Pending Flag
X	A,Mem	EXchange A with Memory	$A \leftrightarrow \text{Mem}$
X	A,[X]	EXchange A with Memory [X]	$A \leftrightarrow [X]$
LD	A,Meml	LoaD A with Memory	$A \leftarrow \text{Meml}$
LD	A,[X]	LoaD A with Memory [X]	$A \leftarrow [X]$
LD	B,Imm	LoaD B with Immed.	$B \leftarrow \text{Imm}$
LD	Mem,Imm	LoaD Memory Immed.	$\text{Mem} \leftarrow \text{Imm}$
LD	Reg,Imm	LoaD Register Memory Immed.	$\text{Reg} \leftarrow \text{Imm}$
X	A, [B ±]	EXchange A with Memory [B]	$A \leftrightarrow [B]$, $(B \leftarrow B \pm 1)$
X	A, [X ±]	EXchange A with Memory [X]	$A \leftrightarrow [X]$, $(X \leftarrow X \pm 1)$
LD	A, [B±]	LoaD A with Memory [B]	$A \leftarrow [B]$, $(B \leftarrow B \pm 1)$
LD	A, [X±]	LoaD A with Memory [X]	$A \leftarrow [X]$, $(X \leftarrow X \pm 1)$
LD	[B±],Imm	LoaD Memory [B] Immed.	$[B] \leftarrow \text{Imm}$, $(B \leftarrow B \pm 1)$
CLR	A	CLear A	$A \leftarrow 0$
INC	A	INCRement A	$A \leftarrow A + 1$
DEC	A	DECrement A	$A \leftarrow A - 1$
LAID		Load A InDirect from ROM	$A \leftarrow \text{ROM (PU,A)}$
DCOR	A	Decimal CORrect A	$A \leftarrow \text{BCD correction of A (follows ADC, SUBC)}$
RRC	A	Rotate A Right thru C	$C \rightarrow A7 \rightarrow \dots \rightarrow A0 \rightarrow C$
RLC	A	Rotate A Left thru C	$C \leftarrow A7 \leftarrow \dots \leftarrow A0 \leftarrow C$, $\text{HC} \leftarrow A0$
SWAP	A	SWAP nibbles of A	$A7 \dots A4 \leftrightarrow A3 \dots A0$
SC		Set C	$C \leftarrow 1$, $\text{HC} \leftarrow 1$
RC		Reset C	$C \leftarrow 0$, $\text{HC} \leftarrow 0$
IFC		IF C	If C is true, do next instruction
IFNC		IF Not C	If C is not true, do next instruction
POP	A	POP the stack into A	$\text{SP} \leftarrow \text{SP} + 1$, $A \leftarrow [\text{SP}]$
PUSH	A	PUSH A onto the stack	$[\text{SP}] \leftarrow A$, $\text{SP} \leftarrow \text{SP} - 1$
VIS		Vector to Interrupt Service Routine	$\text{PU} \leftarrow [\text{VU}]$, $\text{PL} \leftarrow [\text{VL}]$
JMPL	Addr.	Jump absolute Long	$\text{PC} \leftarrow \text{ii}$ (ii = 15 bits, 0 to 32k)
JMP	Addr.	Jump absolute	$\text{PC}9 \dots 0 \leftarrow \text{i}$ (i = 12 bits)
JP	Disp.	Jump relative short	$\text{PC} \leftarrow \text{PC} + r$ (r is -31 to +32, except 1)

13.0 Instruction Set (Continued)

JSRL	Addr.	Jump SubRoutine Long	$[SP] \leftarrow PL, [SP-1] \leftarrow PU, SP-2, PC \leftarrow i$
JSR	Addr.	Jump SubRoutine	$[SP] \leftarrow PL, [SP-1] \leftarrow PU, SP-2, PC \leftarrow i$
JID		Jump InDirect	$PL \leftarrow ROM(PU, A)$
RET		RETurn from subroutine	$SP + 2, PL \leftarrow [SP], PU \leftarrow [SP-1]$
RETSK		RETurn and SKip	$SP + 2, PL \leftarrow [SP], PU \leftarrow [SP-1]$, skip next instruction
RETI		RETurn from Interrupt	$SP + 2, PL \leftarrow [SP], PU \leftarrow [SP-1], GIE \leftarrow 1$
INTR		Generate an Interrupt	$[SP] \leftarrow PL, [SP-1] \leftarrow PU, SP-2, PC \leftarrow 0FF$
NOP		No OPERATION	$PC \leftarrow PC + 1$

13.7 INSTRUCTION EXECUTION TIME

Most instructions are single byte (with immediate addressing mode instructions taking two bytes).

Most single byte instructions take one cycle time to execute.

Skipped instructions require x number of cycles to be skipped, where x equals the number of bytes in the skipped instruction opcode.

See the BYTES and CYCLES per INSTRUCTION table for details.

Bytes and Cycles per Instruction

The following table shows the number of bytes and cycles for each instruction in the format of byte/cycle.

Arithmetic and Logic Instructions

	[B]	Direct	Immed.
ADD	1/1	3/4	2/2
ADC	1/1	3/4	2/2
SUBC	1/1	3/4	2/2
AND	1/1	3/4	2/2
OR	1/1	3/4	2/2
XOR	1/1	3/4	2/2
IFEQ	1/1	3/4	2/2
IFGT	1/1	3/4	2/2
IFBNE	1/1		
DRSZ		1/3	
SBIT	1/1	3/4	
RBIT	1/1	3/4	
IFBIT	1/1	3/4	

RPND	1/1
------	-----

Instructions Using A & C

CLRA	1/1
INCA	1/1
DECA	1/1
LAI	1/3
DCORA	1/1
RRCA	1/1
RLCA	1/1
SWAPA	1/1
SC	1/1
RC	1/1
IFC	1/1
IFNC	1/1
PUSHA	1/3
POPA	1/3
ANDSZ	2/2

Transfer of Control Instructions

JMPL	3/4
JMP	2/3
JP	1/3
JSRL	3/5
JSR	2/5
JID	1/3
VIS	1/5
RET	1/5
RETSK	1/5
RETI	1/5
INTR	1/7
NOP	1/1

13.0 Instruction Set (Continued)

Memory Transfer Instructions

	Register Indirect		Direct	Immed.	Register Indirect Auto Incr. & Decr.		
	[B]	[X]			[B+, B-]	[X+, X-]	
X A, (Note 21)	1/1	1/3	2/3		1/2	1/3	
LD A, (Note 21)	1/1	1/3	2/3	2/2	1/2	1/3	
LD B, Imm				1/1			(If B < 16)
LD B, Imm				2/2			(If B > 15)
LD Mem, Imm	2/2		3/3		2/2		
LD Reg, Imm			2/3				
IFEQ MD, Imm			3/3				

Note 21: = > Memory location addressed by B or X or directly.

13.8 Opcode Table

Upper Nibble											Lower Nibble					
F	E	D	C	B	A	9	8	7	6	5	4	3	2	1	0	
JP-15	JP-31	LD 0F0, #i	DRSZ 0F0	RRCA	RC	ADC A, #i	ADC A _i [B]	IFBIT 0 _i [B]	ANDSZ A, #i	LD B, #0F	IFBNE 0	JSR x000-x0FF	JMP x000-x0FF	JP+17	INTR	
JP-14	JP-30	LD 0F1, #i	DRSZ 0F1	*	SC	SUBC A, #i	SUBC A _i [B]	IFBIT 1 _i [B]	*	LD B, #0E	IFBNE 1	JSR x100-x1FF	JMP x100-x1FF	JP+18	JP+2	
JP-13	JP-29	LD 0F2, #i	DRSZ 0F2	X	X	IFEQ A, #i	IFEQ A _i [B]	IFBIT 2 _i [B]	*	LD B, #0D	IFBNE 2	JSR x200-x2FF	JMP x200-x2FF	JP+19	JP+3	
JP-12	JP-28	LD 0F3, #i	DRSZ 0F3	X	X	IFGT A, #i	IFGT A _i [B]	IFBIT 3 _i [B]	*	LD B, #0C	IFBNE 3	JSR x300-x3FF	JMP x300-x3FF	JP+20	JP+4	
JP-11	JP-27	LD 0F4, #i	DRSZ 0F4	VIS	LAID	ADD A, #i	ADD A _i [B]	IFBIT 4 _i [B]	CLRA	LD B, #0B	IFBNE 4	JSR x400-x4FF	JMP x400-x4FF	JP+21	JP+5	
JP-10	JP-26	LD 0F5, #i	DRSZ 0F5	RPND	JID	AND A, #i	AND A _i [B]	IFBIT 5 _i [B]	SWAPA	LD B, #0A	IFBNE 5	JSR x500-x5FF	JMP x500-x5FF	JP+22	JP+6	
JP-9	JP-25	LD 0F6, #i	DRSZ 0F6	X A _i [X]	X	XOR A, #i	XOR A _i [B]	IFBIT 6 _i [B]	DCORA	LD B, #09	IFBNE 6	JSR x600-x6FF	JMP x600-x6FF	JP+23	JP+7	
JP-8	JP-24	LD 0F7, #i	DRSZ 0F7	*	*	OR A, #i	OR A _i [B]	IFBIT 7 _i [B]	PUSHA	LD B, #08	IFBNE 7	JSR x700-x7FF	JMP x700-x7FF	JP+24	JP+8	
JP-7	JP-23	LD 0F8, #i	DRSZ 0F8	NOP	RLCA	LD A, #i	IFC	SBIT 0 _i [B]	RBIT 0 _i [B]	LD B, #07	IFBNE 8	JSR x800-x8FF	JMP x800-x8FF	JP+25	JP+9	
JP-6	JP-22	LD 0F9, #i	DRSZ 0F9	IFNE A _i [B]	IFEQ Md, #i	IFNE A, #i	IFNC	SBIT 1 _i [B]	RBIT 1 _i [B]	LD B, #06	IFBNE 9	JSR x900-x9FF	JMP x900-x9FF	JP+26	JP+10	
JP-5	JP-21	LD 0FA, #i	DRSZ 0FA	LD A _i [X+]	LD A _i [B+]	LD [B+], #i	INCA	SBIT 2 _i [B]	RBIT 2 _i [B]	LD B, #05	IFBNE 0A	JSR xA00-xAFF	JMP xA00-xAFF	JP+27	JP+11	
JP-4	JP-20	LD 0FB, #i	DRSZ 0FB	LD A _i [X-]	LD A _i [B-]	LD [B-], #i	DECA	SBIT 3 _i [B]	RBIT 3 _i [B]	LD B, #04	IFBNE 0B	JSR xB00-xBFF	JMP xB00-xBFF	JP+28	JP+12	
JP-3	JP-19	LD 0FC, #i	DRSZ 0FC	LD Md, #i	JMPL	X A, Md	POPA	SBIT 4 _i [B]	RBIT 4 _i [B]	LD B, #03	IFBNE 0C	JSR xC00-xCFF	JMP xC00-xCFF	JP+29	JP+13	
JP-2	JP-18	LD 0FD, #i	DRSZ 0FD	DIR	JSRL	LD A, Md	RETSK	SBIT 5 _i [B]	RBIT 5 _i [B]	LD B, #02	IFBNE 0D	JSR xD00-xDFF	JMP xD00-xDFF	JP+30	JP+14	
JP-1	JP-17	LD 0FE, #i	DRSZ 0FE	LD A _i [X]	LD A _i [B]	LD [B], #i	RET	SBIT 6 _i [B]	RBIT 6 _i [B]	LD B, #01	IFBNE 0E	JSR xE00-xEFF	JMP xE00-xEFF	JP+31	JP+15	
JP-0	JP-16	LD 0FF, #i	DRSZ 0FF	*	*	LD B, #i	RETI	SBIT 7 _i [B]	RBIT 7 _i [B]	LD B, #00	IFBNE 0F	JSR xF00-xFFF	JMP xF00-xFFF	JP+32	JP+16	

Where,
i is the immediate data
Md is a directly addressed memory location
* is an unused opcode
The opcode 60 Hex is also the opcode for IFBIT #i,A

14.0 Mask Options

For mask options information on COP8SAx5 devices, please refer to Section 6.4 ECON (CONFIGURATION) REGISTER.

15.0 Development Tools Support

15.1 OVERVIEW

National is engaged with an international community of independent 3rd party vendors who provide hardware and software development tool support. Through National's interaction and guidance, these tools cooperate to form a choice of solutions that fits each developer's needs.

This section provides a summary of the tool and development kits currently available. Up-to-date information, selection guides, free tools, demos, updates, and purchase information can be obtained at our web site at: www.national.com/cop8.

15.2 SUMMARY OF TOOLS

COP8 Evaluation Tools

- **COP8–NSEVAL:** Free Software Evaluation package for Windows. A fully integrated evaluation environment for COP8, including versions of WCOP8 IDE (Integrated Development Environment), COP8-NSASM, COP8-MLSIM, COP8C, DriveWay™ COP8, Manuals, and other COP8 information.
- **COP8–MLSIM:** Free Instruction Level Simulator tool for Windows. For testing and debugging software instructions only (No I/O or interrupt support).
- **COP8–EPU:** Very Low cost COP8 Evaluation & Programming Unit. Windows based evaluation and hardware-simulation tool, with COP8 device programmer and erasable samples. Includes COP8-NSDEV, DriveWay COP8 Demo, MetaLink Debugger, I/O cables and power supply.
- **COP8–EVAL-HIxx:** Low cost target application evaluation and development board for COP8Sx Families, from Hilton Inc. Real-time environment with integrated A/D, Temp Sensor, and Peripheral I/O.
- **COP8–EVAL-ICUxx:** Very Low cost evaluation and design test board for COP8ACC and COP8SGx Families, from ICU. Real-time environment with add-on A/D, D/A, and EEPROM. Includes software routines and reference designs.
- **Manuals, Applications Notes, Literature:** Available free from our web site at: www.national.com/cop8.

COP8 Integrated Software/Hardware Design Development Kits

- **COP8-EPU:** Very Low cost Evaluation & Programming Unit. Windows based development and hardware-simulation tool for COPSx/xG families, with COP8 device programmer and samples. Includes COP8-NSDEV, DriveWay COP8 Demo, MetaLink Debugger, cables and power supply.
- **COP8-DM:** Moderate cost Debug Module from MetaLink. A Windows based, real-time in-circuit emulation tool with COP8 device programmer. Includes COP8-NSDEV, DriveWay COP8 Demo, MetaLink Debugger, power supply, emulation cables and adapters.

COP8 Development Languages and Environments

- **COP8-NSASM:** Free COP8 Assembler v5 for Win32. Macro assembler, linker, and librarian for COP8 software

development. Supports all COP8 devices. (DOS/Win16 v4.10.2 available with limited support). (Compatible with WCOP8 IDE, COP8C, and DriveWay COP8).

- **COP8-NSDEV:** Very low cost Software Development Package for Windows. An integrated development environment for COP8, including WCOP8 IDE, COP8C (limited version), COP8-NSASM, COP8-MLSIM.
- **COP8C:** Moderately priced C Cross-Compiler and Code Development System from Byte Craft (no code limit). Includes BCLIDE (Byte Craft Limited Integrated Development Environment) for Win32, editor, optimizing C Cross-Compiler, macro cross assembler, BC-Linker, and MetaLink tools support. (DOS/SUN versions available; Compiler is installable under WCOP8 IDE; Compatible with DriveWay COP8).
- **EW COP8-KS:** Very Low cost ANSI C-Compiler and Embedded Workbench from IAR (Kickstart version: COP8Sx/Fx only with 2k code limit; No FP). A fully integrated Win32 IDE, ANSI C-Compiler, macro assembler, editor, linker, Librarian, C-Spy simulator/debugger, PLUS MetaLink EPU/DM emulator support.
- **EW COP8-AS:** Moderately priced COP8 Assembler and Embedded Workbench from IAR (no code limit). A fully integrated Win32 IDE, macro assembler, editor, linker, librarian, and C-Spy high-level simulator/debugger with I/O and interrupts support. (Upgradeable with optional C-Compiler and/or MetaLink Debugger/Emulator support).
- **EW COP8-BL:** Moderately priced ANSI C-Compiler and Embedded Workbench from IAR (Baseline version: All COP8 devices; 4k code limit; no FP). A fully integrated Win32 IDE, ANSI C-Compiler, macro assembler, editor, linker, librarian, and C-Spy high-level simulator/debugger. (Upgradeable; CW COP8-M MetaLink tools interface support optional).
- **EW COP8:** Full featured ANSI C-Compiler and Embedded Workbench for Windows from IAR (no code limit). A fully integrated Win32 IDE, ANSI C-Compiler, macro assembler, editor, linker, librarian, and C-Spy high-level simulator/debugger. (CW COP8-M MetaLink tools interface support optional).
- **EW COP8-M:** Full featured ANSI C-Compiler and Embedded Workbench for Windows from IAR (no code limit). A fully integrated Win32 IDE, ANSI C-Compiler, macro assembler, editor, linker, librarian, and C-Spy high-level simulator/debugger, PLUS MetaLink debugger/hardware interface (CW COP8-M).

COP8 Productivity Enhancement Tools

- **WCOP8 IDE:** Very Low cost IDE (Integrated Development Environment) from KKD. Supports COP8C, COP8-NSASM, COP8-MLSIM, DriveWay COP8, and MetaLink debugger under a common Windows Project Management environment. Code development, debug, and emulation tools can be launched from the project window framework.
- **DriveWay-COP8:** Low cost COP8 Peripherals Code Generation tool from Aisys Corporation. Automatically generates tested and documented C or Assembly source code modules containing I/O drivers and interrupt handlers for each on-chip peripheral. Application specific code can be inserted for customization using the integrated editor. (Compatible with COP8-NSASM, COP8C, and WCOP8 IDE.)

15.0 Development Tools Support

(Continued)

- **COP8-UTILS:** Free set of COP8 assembly code examples, device drivers, and utilities to speed up code development.
- **COP8-MLSIM:** Free Instruction Level Simulator tool for Windows. For testing and debugging software instructions only (No I/O or interrupt support).

COP8 Real-Time Emulation Tools

- **COP8-DM:** MetaLink Debug Module. A moderately priced real-time in-circuit emulation tool, with COP8 device programmer. Includes MetaLink Debugger, power supply, emulation cables and adapters.

- **IM-COP8:** MetaLink iceMASTER®. A full featured, real-time in-circuit emulator for COP8 devices. Includes COP8-NSDEV, Driveway COP8 Demo, MetaLink Windows Debugger, and power supply. Package-specific probes and surface mount adaptors are ordered separately.

COP8 Device Programmer Support

- MetaLink's EPU and Debug Module include development device programming capability for COP8 devices.
- Third-party programmers and automatic handling equipment cover needs from engineering prototype and pilot production, to full production environments.
- Factory programming available for high-volume requirements.

15.3 TOOLS ORDERING NUMBERS FOR THE COP8SAx FAMILY DEVICES

Note: The following order numbers apply to the COP8 devices in this datasheet only.

Vendor	Tools	Order Number	Cost	Notes
	COP8-NSEVAL	COP8-NSEVAL	VL	Order from web site.
	COP8-NSDEV	COP8-NSDEV	L	Included in EM. Order CD from web site
	COP8-REF	None		
	COP8-EVAL	COP8-EVAL-COB1	VL	Order from web site
	COP8-EM	COP8-EM-SA	M	Included p/s, 20/28/40 pin DIP target cable, manuals, software
	EM Target Cables and Adapters	COP8-EMC-44P	VL	44 PLCC Target Cable
		COP8-EMC-28CSP	L	28 CSP Target Cable
		COP8-EMA-16D	L	20 DIP to 16 DIP Adapter
		COP8-EMA-xxSO	L	DIP to SOIC Cable Converter
		COP8-EMA-44QFP	L	44 pin PLCC to 44 QFP Cable Converter
	Development Devices	COP8SAC7Q	VL	4k Eraseable/OTP devices
	COP8-PM	COP8-PM-00	L	Included p/s, manuals, software, 16/20/28/40 DIP/SO and 44 PLCC programming socket; add OTP adapter (if needed)
	OTP Programming Adapters	COP8-PGMA-44QFP	L	For programming 44 QFP on any programmer
		COP8-PGMA-28CSP	L	For programming 28 CSP on any programmer
		COP8-PGMA-44CSP	L	For programming 44 CSP on any programmer
		COP8-PGMA-28SO	VL	For programming 16/20/28 SOIC on any programmer

15.0 Development Tools Support (Continued)

MetaLink	COP8-DM	DM5-KCOP8-SA	M	Included p/s (PS-10), target cables (DIP and PLCC), 16/20/28/40 DIP/SO and 44 PLCC programming sockets. Add OTP adapter (if needed) and target adapter (if needed)
	DM Target Adapters	MHW-CNVxx (xx = 33, 34 etc.)	L	DM target converters for 16DIP/20SO/28SO/44QFP/28CSP; (i.e. MHW-CNV38 for 20 pin DIP to SO package converter)
	OTP Programming Adapters	MHW-COP8-PGMA-DS	L	For programming 16/20/28 SOIC and 44 PLCC on the EPU
		MHW-COP8-PGMA-44QFP	L	For programming 44 QFP on any programmer
		MHW-COP8-PGMA-28CSP	L	For programming 28 CSP on any programmer
	COP8-IM	IM-COP8-AD-464 (-220) (10 MHz maximum)	H	Base unit 10 MHz; -220 = 220V; add probe card (required) and target adapter (if needed); included software and manuals
	IM Probe Card	PC-COP8SA44PW-AD-10	M	10 MHz 44 PLCC probe card; 2.5V to 6.0V
		PC-COP8SA40DW-AD-10	M	10 MHz 40 DIP probe card; 2.5V to 6.0V
	IM Probe Target Adapters	MHW-SOICxx (xx = 16, 20, 28)	L	16 or 20 or 28 pin SOIC adapter for probe card
		MHW-CONV33	L	44 pin QFP adapter for 44 PLCC probe card
KKD	WCOP8-IDE	WCOP8-IDE	VL	Included in DM and EM
IAR	EWCOP8-xx	See summary above	L - H	Included all software and manuals
Byte Craft	COP8C	COP8C COP8CWIN	M	Included all software and manuals
Aisys	DriveWay COP8	DriveWay COP8	L	Included all software and manuals
	OTP Programmers	Go to: www.national.com/cop8	L - H	A wide variety world-wide
Cost: Free; VL =< \$100; L = \$100 - \$300; M = \$300 - \$1k; H = \$1k - \$3k; VH = \$3k - \$5k				

15.0 Development Tools Support (Continued)

15.4 WHERE TO GET TOOLS

Tools are ordered directly from the following vendors. Please go to the vendor's web site for current listings of distributors.

Vendor	Home Office	Electronic Sites	Other Main Offices
Aisys	U.S.A.: Santa Clara, CA 1-408-327-8820 fax: 1-408-327-8830	www.aisysinc.com info@aisysinc.com	Distributors
Byte Craft	U.S.A. 1-519-888-6911 fax: 1-519-746-6751	www.bytecraft.com info@bytecraft.com	Distributors
IAR	Sweden: Uppsala +46 18 16 78 00 fax: +46 18 16 78 38	www.iar.se info@iar.se info@iar.com info@iarsys.co.uk info@iar.de	U.S.A.: San Francisco 1-415-765-5500 fax: 1-415-765-5503 U.K.: London +44 171 924 33 34 fax: +44 171 924 53 41 Germany: Munich +49 89 470 6022 fax: +49 89 470 956
ICU	Sweden: Polygonvaegen +46 8 630 11 20 fax: +46 8 630 11 70	www.icu.se support@icu.se support@icu.ch	Switzerland: Hoehe +41 34 497 28 20 fax: +41 34 497 28 21
KKD	Denmark:	www.kkd.dk	
MetaLink	U.S.A.: Chandler, AZ 1-800-638-2423 fax: 1-602-926-1198	www.metaice.com sales@metaice.com support@metaice.com bbs: 1-602-962-0013 www.metalink.de	Germany: Kirchseeon 80-91-5696-0 fax: 80-91-2386 islanger@metalink.de Distributors Worldwide
National	U.S.A.: Santa Clara, CA 1-800-272-9959 fax: 1-800-737-7018	www.national.com/cop8 support@nsc.com europe.support@nsc.com	Europe: +49 (0) 180 530 8585 fax: +49 (0) 180 530 8586 Distributors Worldwide

The following companies have approved COP8 programmers in a variety of configurations. Contact your local office or distributor. You can link to their web sites and get the latest listing of approved programmers from National's COP8 OTP Support page at: www.national.com/cop8.

Advantech; Dataman; EE Tools; Minato; BP Microsystems; Data I/O; Hi-Lo Systems; ICE Technology; Lloyd Research; Logical Devices; MQP; Needhams; Phytton; SMS; Stag Programmers; System General; Tribal Microsystems; Xeltek.

15.5 CUSTOMER SUPPORT

Complete product information and technical support is available from National's customer response centers, and from our on-line COP8 customer support sites.

Physical Dimensions inches (millimeters) unless otherwise noted

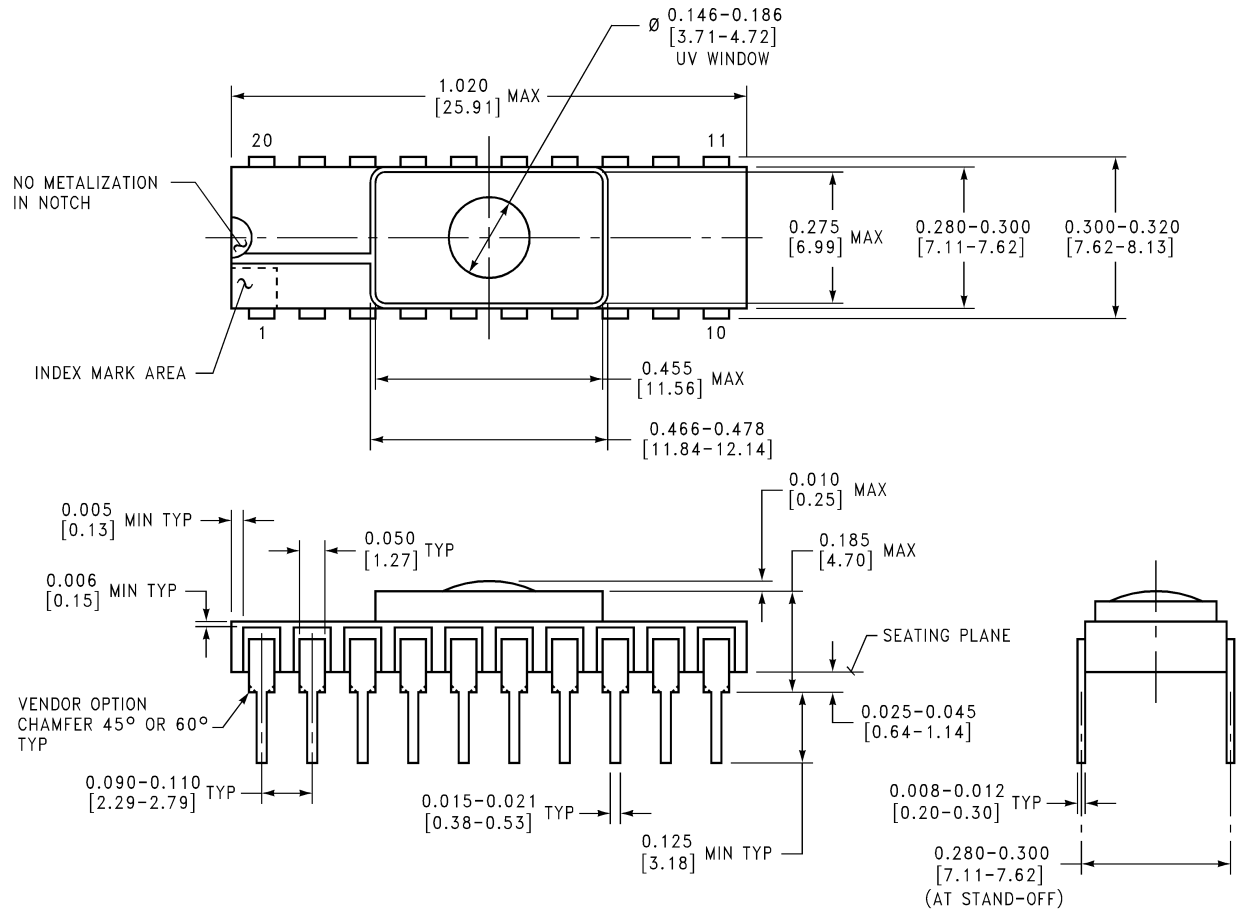

20-Lead Hermetic Dual-In-Line Package, EPROM (D)
Order Number COP8SAC720Q3
NS Package Number D20CQ

D20CQ (REV A)

Physical Dimensions inches (millimeters) unless otherwise noted (Continued)

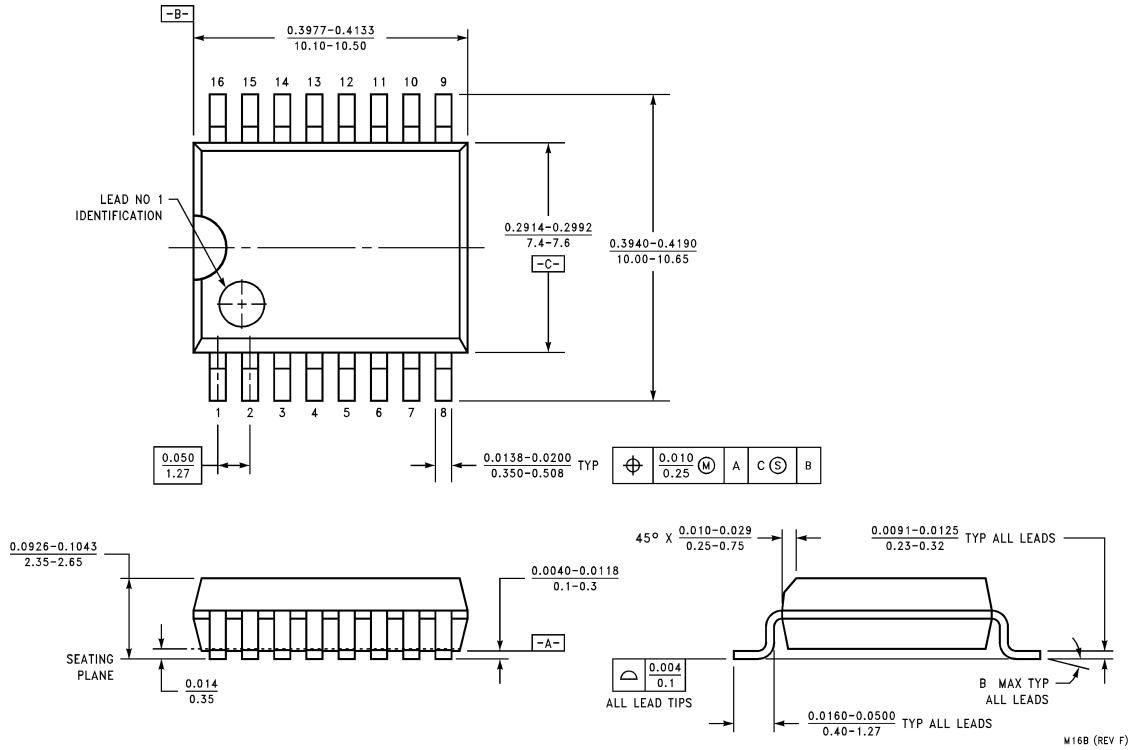

Molded Small Outline Package (WM)
Order Number COP8SAA716M8 or COP8SAA716M9
NS Package Number M16B

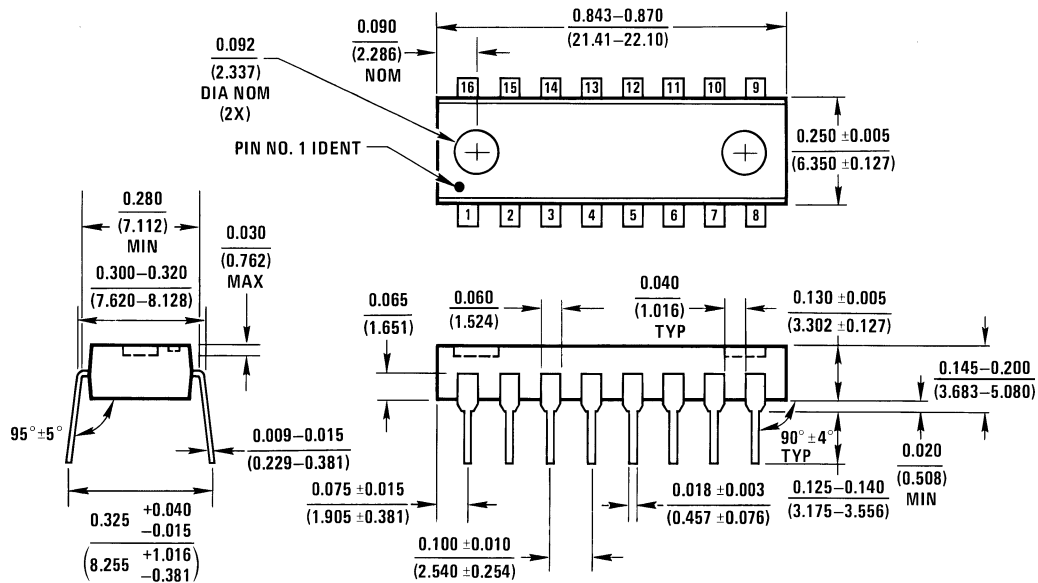

Molded Dual-In-Line Package (N)
Order Number COP8SAA716N8 or COP8SAA716N9
NS Package Number N16A

Physical Dimensions inches (millimeters) unless otherwise noted (Continued)

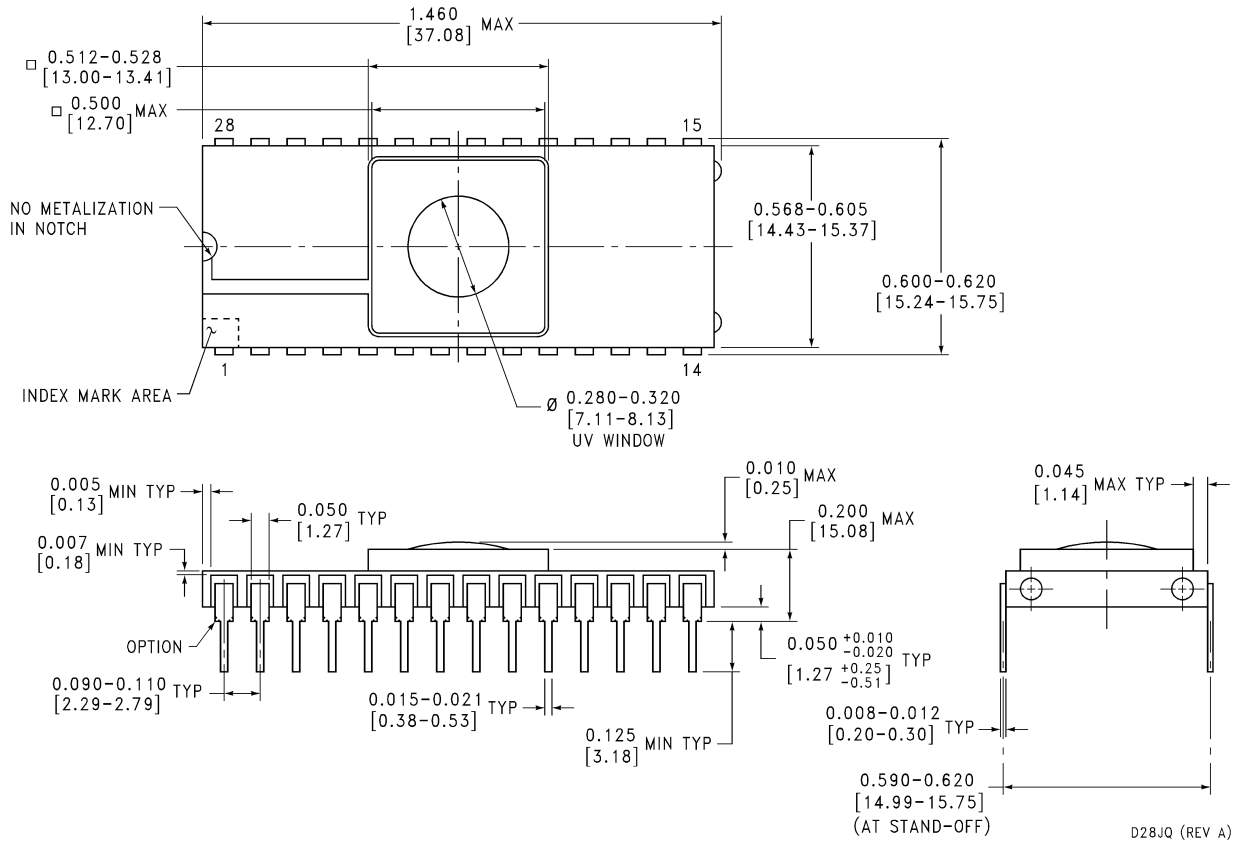

28-Lead Hermetic Dual-In-Line Package EPROM (D)
Order Number COP8SAC728Q3
NS Package Number D28JQ

D28JQ (REV A)

Physical Dimensions inches (millimeters) unless otherwise noted (Continued)

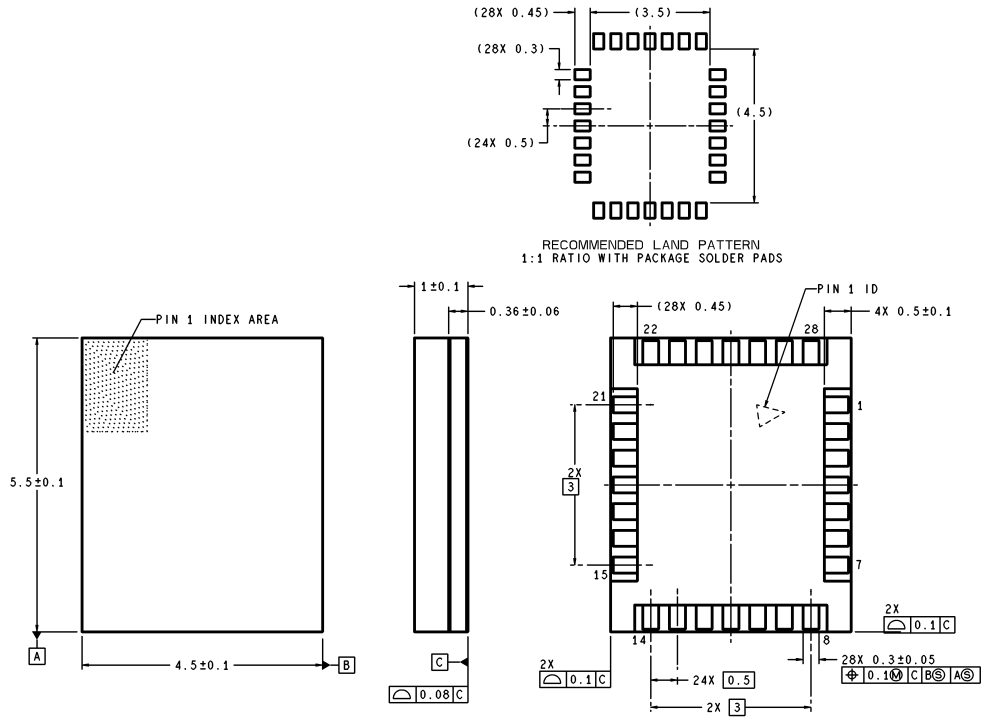

DIMENSIONS ARE IN MILLIMETERS

SLB28A (Rev B)

28 Lead Chip Scale Package (SLB)
Order Number COP8SAA7SLB9, COP8SAB7SLB9 or COP8SAC7SLB9
NS Package Number SLB28A

Physical Dimensions inches (millimeters) unless otherwise noted (Continued)

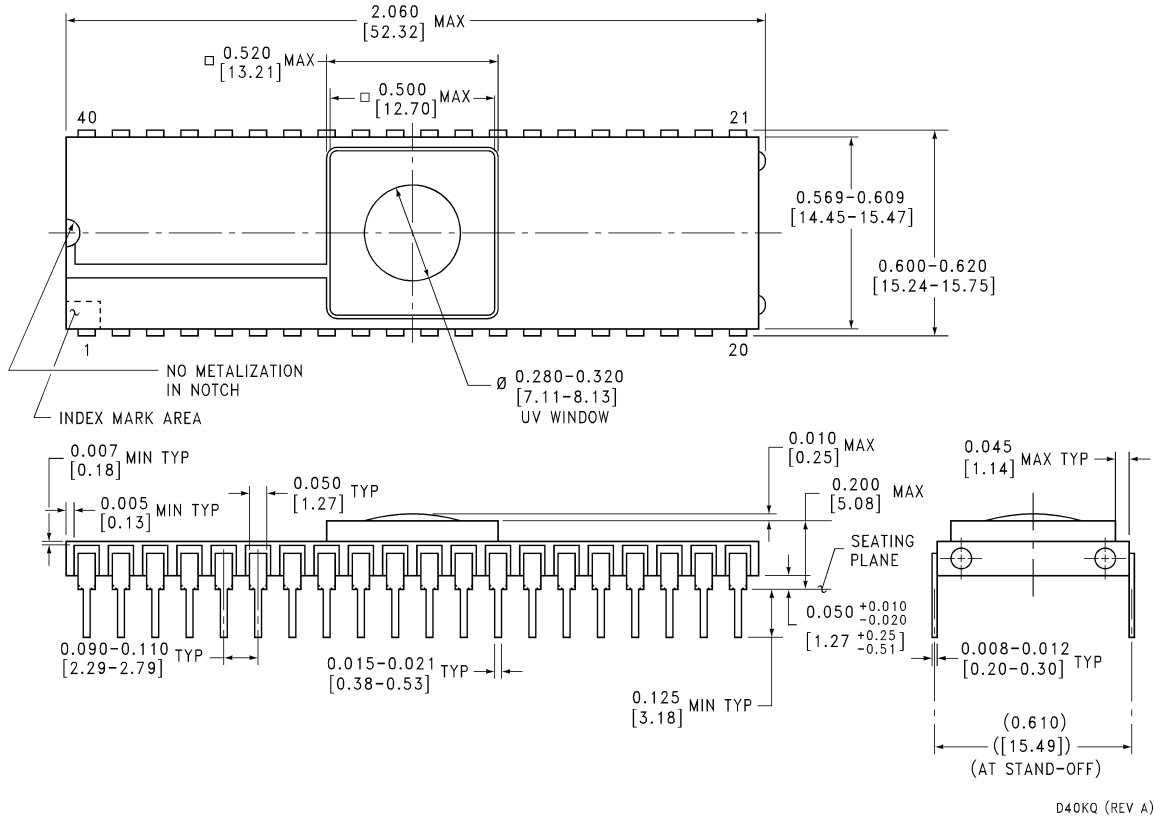

40-Lead Hermetic DIP EPROM (D)
Order Number COP8SAC740Q3
NS Package Number D40KQ

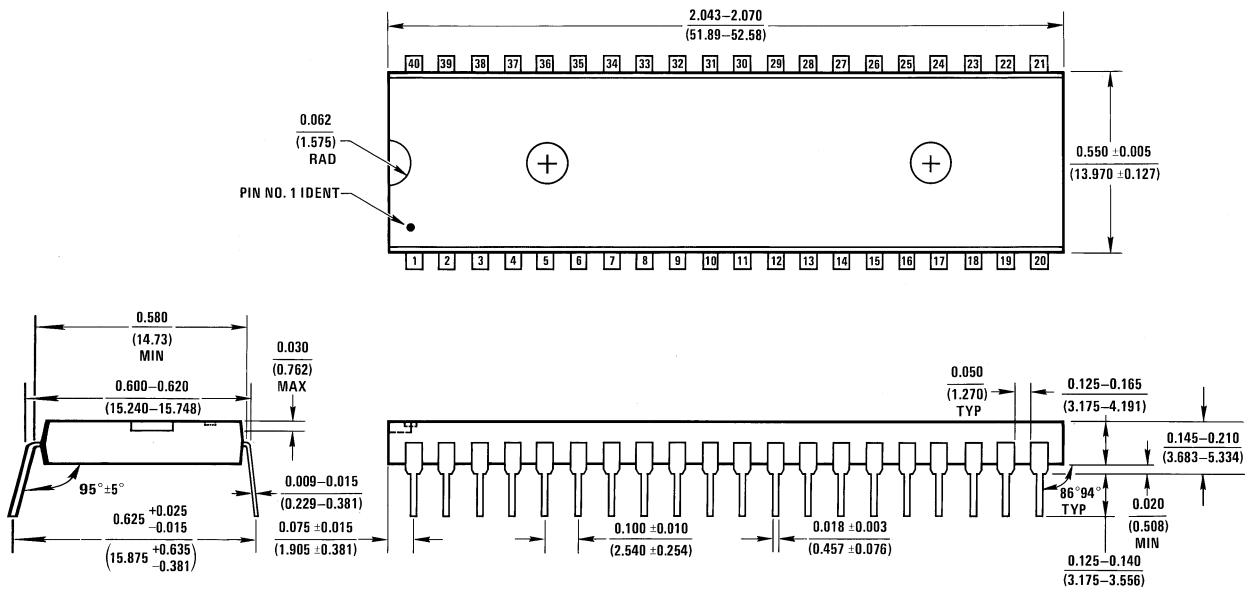

Molded Dual-In-Line Package (N)
Order Number COP8SAC740N9 or COP8SAC740N8
NS Package Number N40A

Physical Dimensions inches (millimeters) unless otherwise noted (Continued)

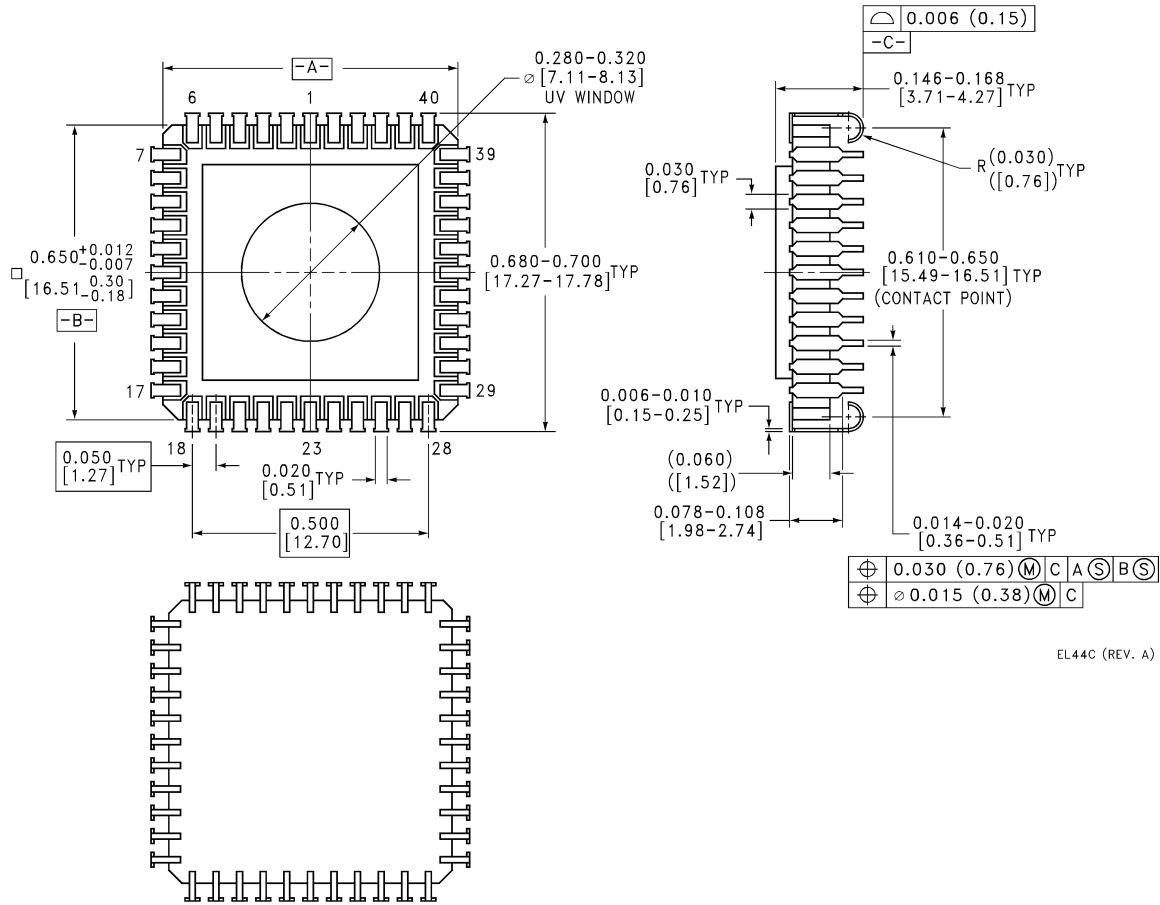

EL44C (REV. A)

44-Lead EPROM Leaded Chip Carrier (EL)
Order Number COP8SAC744Q3
NS Package Number EL44C

Physical Dimensions inches (millimeters) unless otherwise noted (Continued)

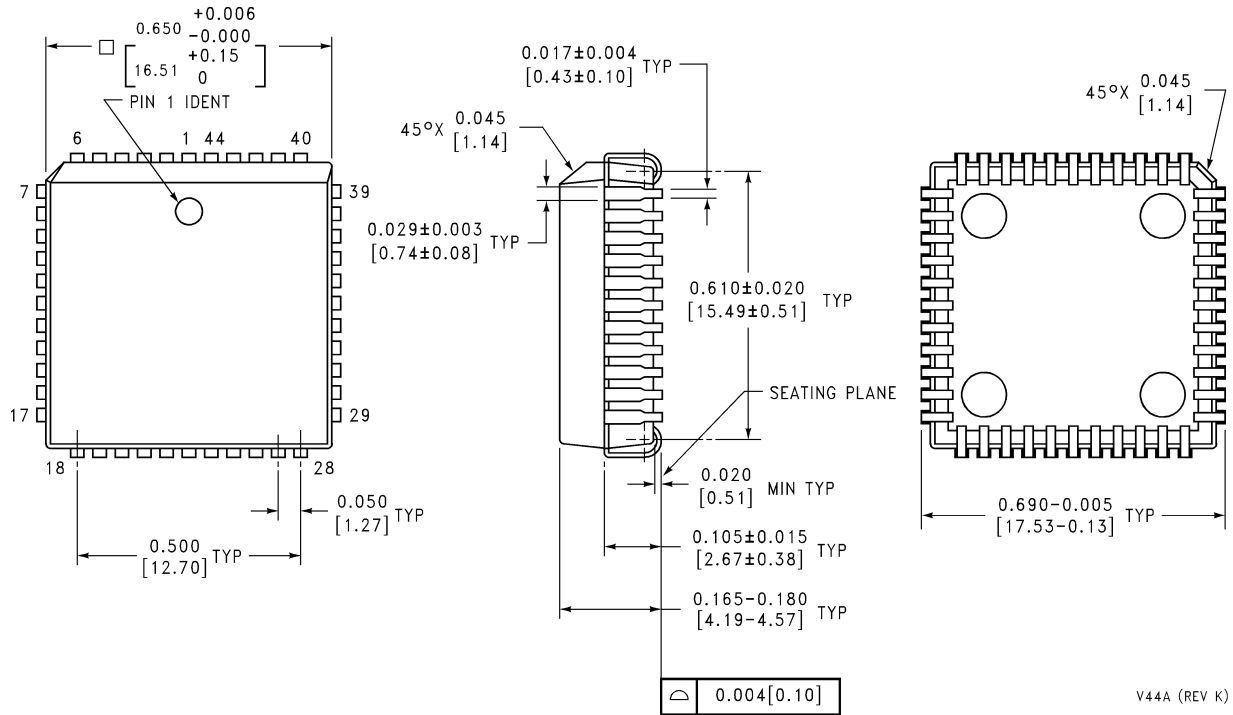

Molded Dual-In-Line Package (N)
Order Number COP8SAC744V9 or COP8SAC744V8
NS Package Number V44A

V44A (REV K)

LIFE SUPPORT POLICY

NATIONAL'S PRODUCTS ARE NOT AUTHORIZED FOR USE AS CRITICAL COMPONENTS IN LIFE SUPPORT DEVICES OR SYSTEMS WITHOUT THE EXPRESS WRITTEN APPROVAL OF THE PRESIDENT AND GENERAL COUNSEL OF NATIONAL SEMICONDUCTOR CORPORATION. As used herein:

1. Life support devices or systems are devices or systems which, (a) are intended for surgical implant into the body, or (b) support or sustain life, and whose failure to perform when properly used in accordance with instructions for use provided in the labeling, can be reasonably expected to result in a significant injury to the user.
2. A critical component is any component of a life support device or system whose failure to perform can be reasonably expected to cause the failure of the life support device or system, or to affect its safety or effectiveness.



National Semiconductor Corporation
 Americas
 Email: support@nsc.com

www.national.com

National Semiconductor Europe
 Fax: +49 (0) 180-530 85 86
 Email: europe.support@nsc.com
 Deutsch Tel: +49 (0) 69 9508 6208
 English Tel: +44 (0) 870 24 0 2171
 Français Tel: +33 (0) 1 41 91 8790

National Semiconductor Asia Pacific Customer Response Group
 Tel: 65-2544466
 Fax: 65-2504466
 Email: ap.support@nsc.com

National Semiconductor Japan Ltd.
 Tel: 81-3-5639-7560
 Fax: 81-3-5639-7507

IMPORTANT NOTICE

Texas Instruments Incorporated and its subsidiaries (TI) reserve the right to make corrections, modifications, enhancements, improvements, and other changes to its products and services at any time and to discontinue any product or service without notice. Customers should obtain the latest relevant information before placing orders and should verify that such information is current and complete. All products are sold subject to TI's terms and conditions of sale supplied at the time of order acknowledgment.

TI warrants performance of its hardware products to the specifications applicable at the time of sale in accordance with TI's standard warranty. Testing and other quality control techniques are used to the extent TI deems necessary to support this warranty. Except where mandated by government requirements, testing of all parameters of each product is not necessarily performed.

TI assumes no liability for applications assistance or customer product design. Customers are responsible for their products and applications using TI components. To minimize the risks associated with customer products and applications, customers should provide adequate design and operating safeguards.

TI does not warrant or represent that any license, either express or implied, is granted under any TI patent right, copyright, mask work right, or other TI intellectual property right relating to any combination, machine, or process in which TI products or services are used. Information published by TI regarding third-party products or services does not constitute a license from TI to use such products or services or a warranty or endorsement thereof. Use of such information may require a license from a third party under the patents or other intellectual property of the third party, or a license from TI under the patents or other intellectual property of TI.

Reproduction of TI information in TI data books or data sheets is permissible only if reproduction is without alteration and is accompanied by all associated warranties, conditions, limitations, and notices. Reproduction of this information with alteration is an unfair and deceptive business practice. TI is not responsible or liable for such altered documentation. Information of third parties may be subject to additional restrictions.

Resale of TI products or services with statements different from or beyond the parameters stated by TI for that product or service voids all express and any implied warranties for the associated TI product or service and is an unfair and deceptive business practice. TI is not responsible or liable for any such statements.

TI products are not authorized for use in safety-critical applications (such as life support) where a failure of the TI product would reasonably be expected to cause severe personal injury or death, unless officers of the parties have executed an agreement specifically governing such use. Buyers represent that they have all necessary expertise in the safety and regulatory ramifications of their applications, and acknowledge and agree that they are solely responsible for all legal, regulatory and safety-related requirements concerning their products and any use of TI products in such safety-critical applications, notwithstanding any applications-related information or support that may be provided by TI. Further, Buyers must fully indemnify TI and its representatives against any damages arising out of the use of TI products in such safety-critical applications.

TI products are neither designed nor intended for use in military/aerospace applications or environments unless the TI products are specifically designated by TI as military-grade or "enhanced plastic." Only products designated by TI as military-grade meet military specifications. Buyers acknowledge and agree that any such use of TI products which TI has not designated as military-grade is solely at the Buyer's risk, and that they are solely responsible for compliance with all legal and regulatory requirements in connection with such use.

TI products are neither designed nor intended for use in automotive applications or environments unless the specific TI products are designated by TI as compliant with ISO/TS 16949 requirements. Buyers acknowledge and agree that, if they use any non-designated products in automotive applications, TI will not be responsible for any failure to meet such requirements.

Following are URLs where you can obtain information on other Texas Instruments products and application solutions:

Products

Audio	www.ti.com/audio
Amplifiers	amplifier.ti.com
Data Converters	dataconverter.ti.com
DLP® Products	www.dlp.com
DSP	dsp.ti.com
Clocks and Timers	www.ti.com/clocks
Interface	interface.ti.com
Logic	logic.ti.com
Power Mgmt	power.ti.com
Microcontrollers	microcontroller.ti.com
RFID	www.ti-rfid.com
OMAP Mobile Processors	www.ti.com/omap
Wireless Connectivity	www.ti.com/wirelessconnectivity

Applications

Communications and Telecom	www.ti.com/communications
Computers and Peripherals	www.ti.com/computers
Consumer Electronics	www.ti.com/consumer-apps
Energy and Lighting	www.ti.com/energy
Industrial	www.ti.com/industrial
Medical	www.ti.com/medical
Security	www.ti.com/security
Space, Avionics and Defense	www.ti.com/space-avionics-defense
Transportation and Automotive	www.ti.com/automotive
Video and Imaging	www.ti.com/video

TI E2E Community Home Page

e2e.ti.com

Mailing Address: Texas Instruments, Post Office Box 655303, Dallas, Texas 75265
Copyright © 2011, Texas Instruments Incorporated

Looking for pricing, stock, or lifecycle information?

Click below to explore more details on WIN SOURCE:

 [View COP8SAC720N8](#) on WIN SOURCE

 [Texas Instruments](#) Information

Optimize Your Supply Chain with WIN SOURCE Solutions

-  Global Sourcing Solution
-  Obsolete Management
-  Cost Control Management
-  Shortage Management
-  Alternative Solution
-  Excess Inventory Management