



THE DATASHEET OF UC2835N



High Efficiency Regulator Controller

FEATURES

- Complete Control for a High Current, Low Dropout, Linear Regulator
- Fixed 5V or Adjustable Output Voltage
- Accurate 2.5A Current Limiting with Foldback
- Internal Current Sense Resistor
- Remote Sense for Improved Load Regulation
- External Shutdown
- Under-Voltage Lockout and Reverse Voltage Protection
- Thermal Shutdown Protection
- 8 Pin Mini-Dip Package (Surface Mount also Available)

DESCRIPTION

The UC1835/6 families of linear controllers are optimized for the design of low cost, low dropout, linear regulators. Using an external pass element, dropout voltages of less than 0.5V are readily obtained. These devices contain a high gain error amplifier, a 250mA output driver, and a precision reference. In addition, current sense with foldback provides for a 2.5A peak output current dropping to less than 0.5A at short circuit.

These devices are available in fixed, 5V, (UC1835), or adjustable, (UC1836), versions. In the fixed 5 volt version, the only external parts required are an external pass element, an output capacitor, and a compensation capacitor. On the adjustable version the output voltage can be set anywhere from 2.5V to 35V with two external resistors.

Additional features of these devices include under-voltage lockout for predictable start-up, thermal shutdown and short circuit current limiting to protect the driver device. On the fixed voltage version, a reverse voltage comparator minimizes reverse load current in the event of a negative input to output differential.

BLOCK DIAGRAM

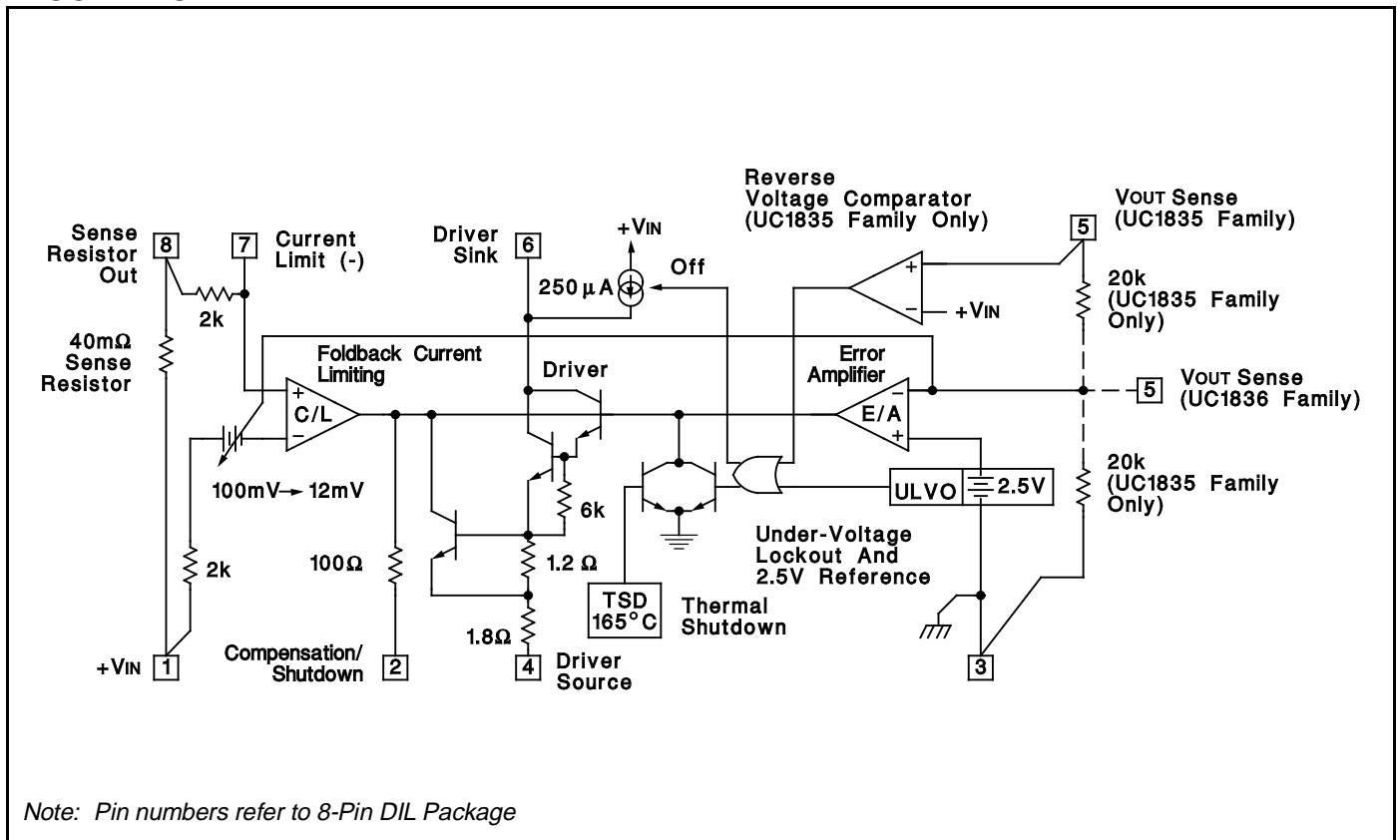

ABSOLUTE MAXIMUM RATINGS (Note 1)

Input Supply Voltage (+VIN) -1.0V to +40V
 Driver Output Current (Sink or Source) 600mA
 Driver Source to Sink Voltage +40V
 Maximum Current Through Sense Resistor. 4A
 VOUT Sense Input Voltage -3V to +40V
 Power Dissipation at TA = 25°C (Note 2) 1000mW
 Power Dissipation at Tc = 25°C (Note 2) 2000mW

Operating Junction Temperature -55°C to +150°C
 Storage Temperature -65°C to +150°C
 Lead Temperature (Soldering, 10 Seconds) 300°C

*Note 1: Voltages are referenced to ground, (Pin 3). Currents are positive into, negative out of, the specified terminals.
 Consult Packaging Section of Databook for thermal considerations and limitations of packages.*

CONNECTION DIAGRAMS

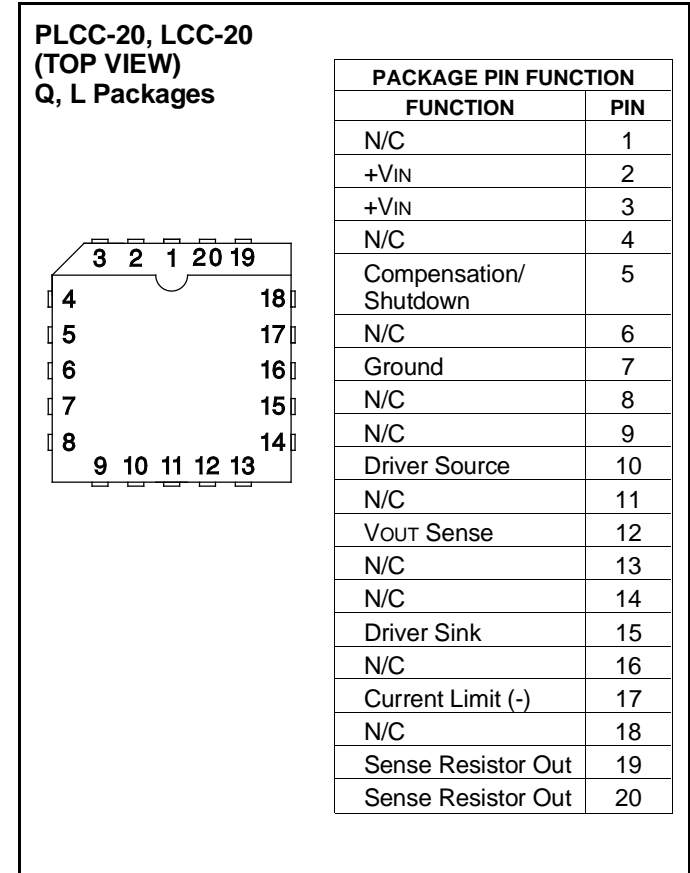
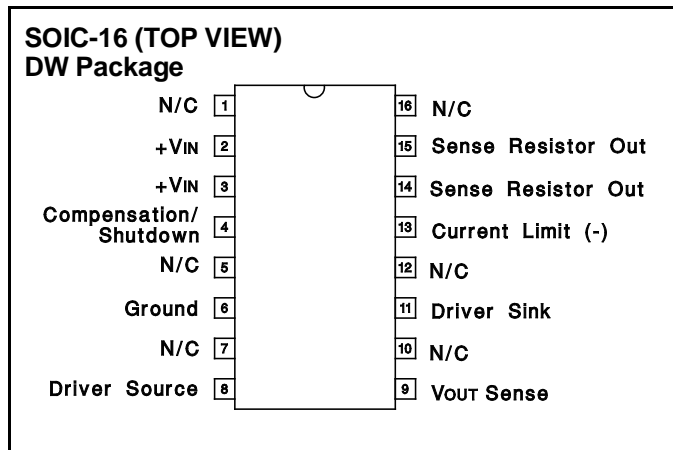
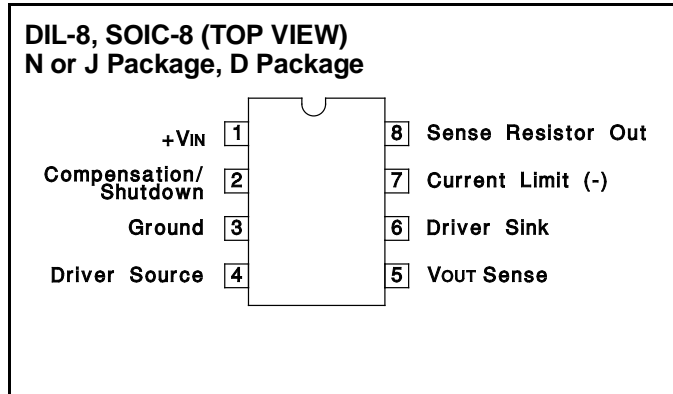

ELECTRICAL CHARACTERISTICS: Unless otherwise stated, specifications hold for TA = 0°C to +70°C for the UC3835/6, -25°C to +85°C for the UC2835/6, and -55°C to +125°C for the UC1835/6, +VIN = 6V, Driver Source= 0V, Driver Sink = 5V, TA = TJ.

PARAMETER	TEST CONDITIONS	MIN.	TYP.	MAX.	UNITS
Input Supply					
Supply Current	+VIN = 6V		2.75	4.0	mA
	+VIN = 40V		3.75	6.0	mA
UVLO Threshold	+VIN Low to High, VOUT Sense = 0V	3.9	4.4	4.9	V
Threshold Hysteresis			0.1	0.35	V
Reverse Current	+VIN = -1.0V, Driver Sink Open		6.0	20	mA
Regulating Voltage and Error Amplifier (UC1835 Family Only)					
Regulating Level at VOUT Sense (VREG)	Driver Current = 10mA, TJ = 25°C	4.94	5.0	5.06	V
	Over Temperature	4.9		5.1	V
Line Regulation	+VIN = 5.2V + 35V		15	40	mV
Load Regulation	Driver Current = 0 to 250mA		6.0	25	mV
Bias Current at VOUT Sense	VOUT Sense = 5.0V	75	125	210	µA
Error Amp Transconductance	±100µA at Compensation/Shutdown Pin	0.8	1.3	2.0	mS
Maximum Compensation Output Current	Sink or Source, Driver Source Open	90	200	260	µA

ELECTRICAL CHARACTERISTICS: Unless otherwise stated, specifications hold for $T_A = 0^\circ\text{C}$ to $+70^\circ\text{C}$ for the UC3835/6, -25°C to $+85^\circ\text{C}$ for the UC2835/6, and -55°C to $+125^\circ\text{C}$ for the UC1835/6, $+V_{IN} = 6\text{V}$, Driver Source = 0V , Driver Sink = 5V , $T_A = T_J$.

PARAMETER	TEST CONDITIONS	MIN.	TYP.	MAX.	UNITS
Regulating Voltage and Error Amplifier (UC1836 Family Only)					
Regulating Level at V_{OUT} Sense (V_{REG})	Driver Current = 10mA , $T_J = 25^\circ\text{C}$	2.47	2.5	2.53	V
	Over Temperature	2.45		2.55	V
Line Regulation	$+V_{IN} = 5.2\text{V}$ to 35V		6.0	20	mV
Load Regulation	Driver Current = 0 to 250mA		3.0	15	mV
Bias Current at V_{OUT} Sense	V_{OUT} Sense = 2.5V	-1.0	-0.2		μA
Error Amp Transconductance	$\pm 100\mu\text{A}$ at Compensation/Shutdown Pin	0.8	1.3	2.0	mS
Maximum Compensation Output Current	Sink or Source, Driver Source Open	90	200	260	μA
Driver					
Maximum Current		250	500		mA
Saturation Voltage	Driver Current = 250mA , Driver Sink		2.0	2.8	V
Pull-Up Current at Driver Sink	Compensation/Shutdown = 0.45V	140	250	300	μA
Driver Sink Leakage	In UVLO			10	μA
	In Reverse Voltage (UC1835 Family Only)			10	μA
Thermal Shutdown			165		$^\circ\text{C}$
Foldback Current Limit					
Current Limit Levels at Sense Resistor Out	V_{OUT} Sense = $(0.99) V_{REG}$	2.2	2.5	2.8	A
	V_{OUT} Sense = $(0.5) V_{REG}$	1.3	1.5	1.7	A
	V_{OUT} Sense = 0V	0.25	0.4	0.55	A
Current Limit Amp Transconductance	$\pm 100\mu\text{A}$ at Compensation/Shutdown, V_{OUT} Sense = $(0.9) V_{REG}$	12	24	42	mS
Limiting Voltage at Current Limit (-) (Note 2)	V_{OUT} Sense = $(0.9) V_{REG}$ Volts Below $+V_{IN}$, $T_J = 25^\circ\text{C}$	80	100	140	mV
Sense Resistor Value (Note 3)	V_{OUT} Sense = $(0.9) V_{REG}$, $I_{OUT} = I_A$, $T_J = 25^\circ\text{C}$		40		$\text{m}\Omega$

Note 2: This voltage has a positive temperature coefficient of approximately $3500\text{ppm}/^\circ\text{C}$.

Note 3: This resistance has a positive temperature coefficient of approximately $3500\text{ppm}/^\circ\text{C}$.

The total resistance from Pin 1 to Pin 8 will include an additional 60 to $100\text{m}\Omega$ of package resistance.

APPLICATION AND OPERATION INFORMATION

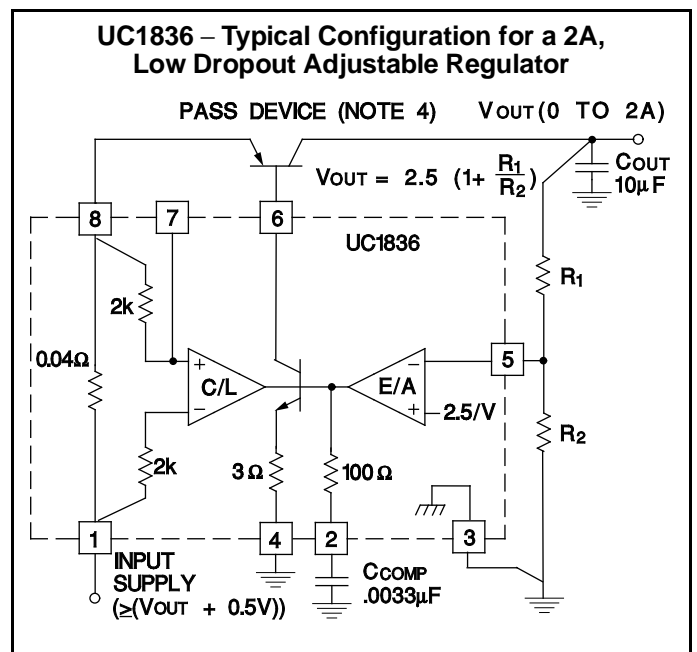
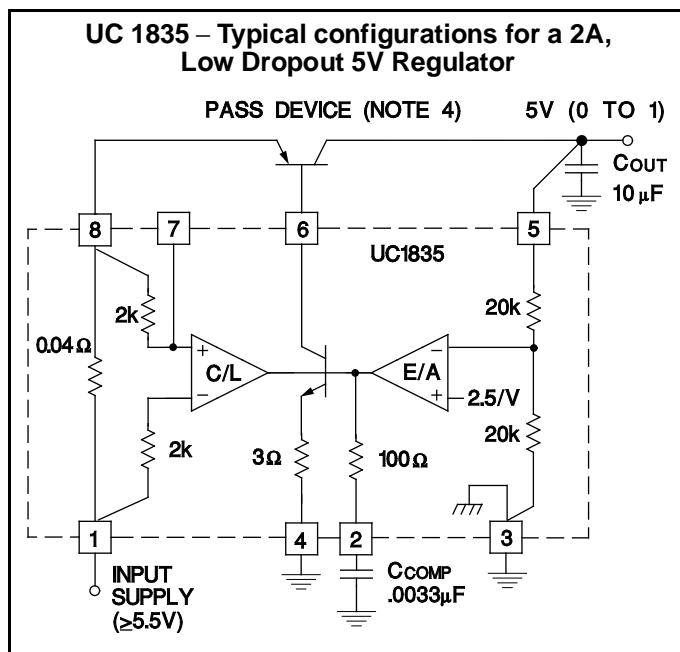

Note 4: Suggested Pass devices are TIP 32B. (Dropout Voltage $\leq 0.75\text{V}$) or, D45H, (Dropout Voltage $\leq 0.5\text{V}$), or equivalents.

APPLICATION AND OPERATION INFORMATION (cont.)

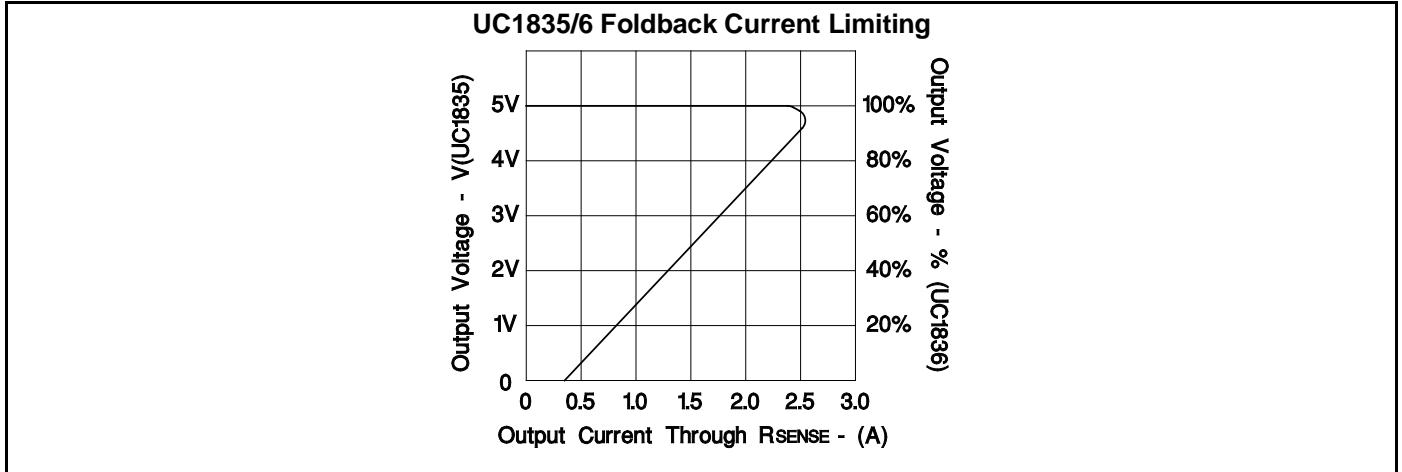

UC3835/36 TYPICAL APPLICATIONS

Low Current Application
using the UC3836 internal drive transistor

Typical Output Current vs VIN and VOUT
of the UC3836 internal drive transistor
for PDISS = 0.5W (approx.)

		VIN					
		Volts	5	9	12	15	18
VOUT	2	150	60	40	30	20	12
	5		105	55	35	25	15
	9			130	60	35	20
	12				120	55	25
	15					110	30
		Current in mA					

High Current Application
using drive transistor Q2 to increase Q1 base drive
and reduce UC3836 power dissipation

Parallel Pass Transistors
can be added for high current or
high power dissipation applications

EQUATIONS:
 $R1 = 0.100 V/I_{OUT} (MAX)$
 $R2 = (V_{OUT} - 2.5V/1mA)$
 $R3 = ((V_{IN} - V_{BE} - V_{SAT}) * BETA(min)) / I_{OUT} (max)$

PACKAGING INFORMATION

Orderable Device	Status (1)	Package Type	Package Drawing	Pins	Package Qty	Eco Plan (2)	Lead/Ball Finish (6)	MSL Peak Temp (3)	Op Temp (°C)	Device Marking (4/5)	Samples
5962-9065002PA	ACTIVE	CDIP	JG	8	1	TBD	A42	N / A for Pkg Type	-55 to 125	9065002PA UC1836	Samples
UC1835J	OBSOLETE	CDIP	JG	8		TBD	Call TI	Call TI	-55 to 125		
UC1835J883B	OBSOLETE	CDIP	JG	8		TBD	Call TI	Call TI	-55 to 125		
UC1835L883B	OBSOLETE	LCCC	FK	20		TBD	Call TI	Call TI	-55 to 125		
UC1836J	ACTIVE	CDIP	JG	8	1	TBD	A42	N / A for Pkg Type	-55 to 125	UC1836J	Samples
UC1836J883B	ACTIVE	CDIP	JG	8	1	TBD	A42	N / A for Pkg Type	-55 to 125	9065002PA UC1836	Samples
UC1836L	OBSOLETE	TO/SOT	L	20		TBD	Call TI	Call TI	-55 to 125		
UC1836L883B	OBSOLETE	TO/SOT	L	20		TBD	Call TI	Call TI	-55 to 125		
UC2835D	ACTIVE	SOIC	D	8	75	Green (RoHS & no Sb/Br)	CU NIPDAU	Level-2-260C-1 YEAR	-25 to 85	UC2835D	Samples
UC2835J	OBSOLETE	CDIP	JG	8		TBD	Call TI	Call TI	-25 to 85		
UC2835N	LIFEBUY	PDIP	P	8	50	Green (RoHS & no Sb/Br)	CU NIPDAU	N / A for Pkg Type	-25 to 85	UC2835N	
UC2836D	ACTIVE	SOIC	D	8	75	Green (RoHS & no Sb/Br)	CU NIPDAU	Level-2-260C-1 YEAR	-25 to 85	UC2836D	Samples
UC2836DG4	ACTIVE	SOIC	D	8	75	Green (RoHS & no Sb/Br)	CU NIPDAU	Level-2-260C-1 YEAR	-25 to 85	UC2836D	Samples
UC2836DW	OBSOLETE	SOIC	DW	16		TBD	Call TI	Call TI	-25 to 85		
UC3835N	NRND	PDIP	P	8	50	Green (RoHS & no Sb/Br)	CU NIPDAU	N / A for Pkg Type	0 to 70	UC3835N	
UC3836D	ACTIVE	SOIC	D	8	75	Green (RoHS & no Sb/Br)	CU NIPDAU	Level-2-260C-1 YEAR	0 to 70	UC3836D	Samples
UC3836DG4	ACTIVE	SOIC	D	8	75	Green (RoHS & no Sb/Br)	CU NIPDAU	Level-2-260C-1 YEAR	0 to 70	UC3836D	Samples
UC3836DTR	ACTIVE	SOIC	D	8	2500	Green (RoHS & no Sb/Br)	CU NIPDAU	Level-2-260C-1 YEAR	0 to 70	UC3836D	Samples
UC3836N	NRND	PDIP	P	8	50	Green (RoHS & no Sb/Br)	CU NIPDAU	N / A for Pkg Type	0 to 70	UC3836N	
UC3836NG4	NRND	PDIP	P	8	50	Green (RoHS & no Sb/Br)	CU NIPDAU	N / A for Pkg Type	0 to 70	UC3836N	

(1) The marketing status values are defined as follows:

ACTIVE: Product device recommended for new designs.

LIFEBUY: TI has announced that the device will be discontinued, and a lifetime-buy period is in effect.

NRND: Not recommended for new designs. Device is in production to support existing customers, but TI does not recommend using this part in a new design.

PREVIEW: Device has been announced but is not in production. Samples may or may not be available.

OBSOLETE: TI has discontinued the production of the device.

(2) Eco Plan - The planned eco-friendly classification: Pb-Free (RoHS), Pb-Free (RoHS Exempt), or Green (RoHS & no Sb/Br) - please check <http://www.ti.com/productcontent> for the latest availability information and additional product content details.

TBD: The Pb-Free/Green conversion plan has not been defined.

Pb-Free (RoHS): TI's terms "Lead-Free" or "Pb-Free" mean semiconductor products that are compatible with the current RoHS requirements for all 6 substances, including the requirement that lead not exceed 0.1% by weight in homogeneous materials. Where designed to be soldered at high temperatures, TI Pb-Free products are suitable for use in specified lead-free processes.

Pb-Free (RoHS Exempt): This component has a RoHS exemption for either 1) lead-based flip-chip solder bumps used between the die and package, or 2) lead-based die adhesive used between the die and leadframe. The component is otherwise considered Pb-Free (RoHS compatible) as defined above.

Green (RoHS & no Sb/Br): TI defines "Green" to mean Pb-Free (RoHS compatible), and free of Bromine (Br) and Antimony (Sb) based flame retardants (Br or Sb do not exceed 0.1% by weight in homogeneous material)

(3) MSL, Peak Temp. - The Moisture Sensitivity Level rating according to the JEDEC industry standard classifications, and peak solder temperature.

(4) There may be additional marking, which relates to the logo, the lot trace code information, or the environmental category on the device.

(5) Multiple Device Markings will be inside parentheses. Only one Device Marking contained in parentheses and separated by a "-" will appear on a device. If a line is indented then it is a continuation of the previous line and the two combined represent the entire Device Marking for that device.

(6) Lead/Ball Finish - Orderable Devices may have multiple material finish options. Finish options are separated by a vertical ruled line. Lead/Ball Finish values may wrap to two lines if the finish value exceeds the maximum column width.

Important Information and Disclaimer:The information provided on this page represents TI's knowledge and belief as of the date that it is provided. TI bases its knowledge and belief on information provided by third parties, and makes no representation or warranty as to the accuracy of such information. Efforts are underway to better integrate information from third parties. TI has taken and continues to take reasonable steps to provide representative and accurate information but may not have conducted destructive testing or chemical analysis on incoming materials and chemicals. TI and TI suppliers consider certain information to be proprietary, and thus CAS numbers and other limited information may not be available for release.

In no event shall TI's liability arising out of such information exceed the total purchase price of the TI part(s) at issue in this document sold by TI to Customer on an annual basis.

OTHER QUALIFIED VERSIONS OF UC1835, UC1836, UC3835, UC3836 :

● Catalog: [UC3835](#), [UC3836](#)

● Military: [UC1835](#), [UC1836](#)

NOTE: Qualified Version Definitions:

- Catalog - TI's standard catalog product
- Military - QML certified for Military and Defense Applications

TAPE AND REEL INFORMATION
REEL DIMENSIONS

TAPE DIMENSIONS

A0	Dimension designed to accommodate the component width
B0	Dimension designed to accommodate the component length
K0	Dimension designed to accommodate the component thickness
W	Overall width of the carrier tape
P1	Pitch between successive cavity centers

TAPE AND REEL INFORMATION

*All dimensions are nominal

Device	Package Type	Package Drawing	Pins	SPQ	Reel Diameter (mm)	Reel Width W1 (mm)	A0 (mm)	B0 (mm)	K0 (mm)	P1 (mm)	W (mm)	Pin1 Quadrant
UC3836DTR	SOIC	D	8	2500	330.0	12.4	6.4	5.2	2.1	8.0	12.0	Q1

TAPE AND REEL BOX DIMENSIONS



*All dimensions are nominal

Device	Package Type	Package Drawing	Pins	SPQ	Length (mm)	Width (mm)	Height (mm)
UC3836DTR	SOIC	D	8	2500	367.0	367.0	35.0

IMPORTANT NOTICE

Texas Instruments Incorporated and its subsidiaries (TI) reserve the right to make corrections, enhancements, improvements and other changes to its semiconductor products and services per JESD46, latest issue, and to discontinue any product or service per JESD48, latest issue. Buyers should obtain the latest relevant information before placing orders and should verify that such information is current and complete. All semiconductor products (also referred to herein as "components") are sold subject to TI's terms and conditions of sale supplied at the time of order acknowledgment.

TI warrants performance of its components to the specifications applicable at the time of sale, in accordance with the warranty in TI's terms and conditions of sale of semiconductor products. Testing and other quality control techniques are used to the extent TI deems necessary to support this warranty. Except where mandated by applicable law, testing of all parameters of each component is not necessarily performed.

TI assumes no liability for applications assistance or the design of Buyers' products. Buyers are responsible for their products and applications using TI components. To minimize the risks associated with Buyers' products and applications, Buyers should provide adequate design and operating safeguards.

TI does not warrant or represent that any license, either express or implied, is granted under any patent right, copyright, mask work right, or other intellectual property right relating to any combination, machine, or process in which TI components or services are used. Information published by TI regarding third-party products or services does not constitute a license to use such products or services or a warranty or endorsement thereof. Use of such information may require a license from a third party under the patents or other intellectual property of the third party, or a license from TI under the patents or other intellectual property of TI.

Reproduction of significant portions of TI information in TI data books or data sheets is permissible only if reproduction is without alteration and is accompanied by all associated warranties, conditions, limitations, and notices. TI is not responsible or liable for such altered documentation. Information of third parties may be subject to additional restrictions.

Resale of TI components or services with statements different from or beyond the parameters stated by TI for that component or service voids all express and any implied warranties for the associated TI component or service and is an unfair and deceptive business practice. TI is not responsible or liable for any such statements.

Buyer acknowledges and agrees that it is solely responsible for compliance with all legal, regulatory and safety-related requirements concerning its products, and any use of TI components in its applications, notwithstanding any applications-related information or support that may be provided by TI. Buyer represents and agrees that it has all the necessary expertise to create and implement safeguards which anticipate dangerous consequences of failures, monitor failures and their consequences, lessen the likelihood of failures that might cause harm and take appropriate remedial actions. Buyer will fully indemnify TI and its representatives against any damages arising out of the use of any TI components in safety-critical applications.

In some cases, TI components may be promoted specifically to facilitate safety-related applications. With such components, TI's goal is to help enable customers to design and create their own end-product solutions that meet applicable functional safety standards and requirements. Nonetheless, such components are subject to these terms.

No TI components are authorized for use in FDA Class III (or similar life-critical medical equipment) unless authorized officers of the parties have executed a special agreement specifically governing such use.

Only those TI components which TI has specifically designated as military grade or "enhanced plastic" are designed and intended for use in military/aerospace applications or environments. Buyer acknowledges and agrees that any military or aerospace use of TI components which have **not** been so designated is solely at the Buyer's risk, and that Buyer is solely responsible for compliance with all legal and regulatory requirements in connection with such use.

TI has specifically designated certain components as meeting ISO/TS16949 requirements, mainly for automotive use. In any case of use of non-designated products, TI will not be responsible for any failure to meet ISO/TS16949.

Products

Audio	www.ti.com/audio
Amplifiers	amplifier.ti.com
Data Converters	dataconverter.ti.com
DLP® Products	www.dlp.com
DSP	dsp.ti.com
Clocks and Timers	www.ti.com/clocks
Interface	interface.ti.com
Logic	logic.ti.com
Power Mgmt	power.ti.com
Microcontrollers	microcontroller.ti.com
RFID	www.ti-rfid.com
OMAP Applications Processors	www.ti.com/omap
Wireless Connectivity	www.ti.com/wirelessconnectivity

Applications



Automotive and Transportation	www.ti.com/automotive
Communications and Telecom	www.ti.com/communications
Computers and Peripherals	www.ti.com/computers
Consumer Electronics	www.ti.com/consumer-apps
Energy and Lighting	www.ti.com/energy
Industrial	www.ti.com/industrial
Medical	www.ti.com/medical
Security	www.ti.com/security
Space, Avionics and Defense	www.ti.com/space-avionics-defense
Video and Imaging	www.ti.com/video

TI E2E Community

e2e.ti.com

Looking for pricing, stock, or lifecycle information?

Click below to explore more details on WIN SOURCE:

-  [View UC2835N on WIN SOURCE](#)
-  [Texas Instruments](#) Information

Optimize Your Supply Chain with WIN SOURCE Solutions

-  Global Sourcing Solution
-  Obsolete Management
-  Cost Control Management
-  Shortage Management
-  Alternative Solution
-  Excess Inventory Management