



**THE DATASHEET OF
TLV320AIC3256IRSBT**



TLV320AIC3256 Ultra Low Power Stereo Audio Codec With Embedded miniDSP

1 Features

- Stereo Audio DAC with 100dB SNR
- 5.0mW Stereo 48ksps DAC-to-Ground-Centered Headphone Playback
- Stereo Audio ADC with 93dB SNR
- 5.2mW Stereo 48ksps ADC Record
- PowerTune™
- Extensive Signal Processing Options
- Embedded miniDSP
- Six Single-Ended or 3 Fully-Differential Analog Inputs
- Stereo Analog and Digital Microphone Inputs
- Ground-Centered Stereo Headphone Outputs
- Very Low-Noise PGA
- Low Power Analog Bypass Mode
- Programmable Microphone Bias
- Programmable PLL
- 5mm x 5mm 40-pin QFN Package or 3.5mm x 3.3mm 42-ball WCSP

2 Applications

- Portable Navigation Devices (PND)
- Portable Media Player (PMP)
- Mobile Handsets
- Communication
- Portable Computing
- Advanced DSP algorithms

3 Description

The TLV320AIC3256 (also called the AIC3256) is a flexible, low-power, low-voltage stereo audio codec with programmable inputs and outputs, PowerTune capabilities, fully-programmable miniDSP, fixed predefined and parameterizable signal processing blocks, integrated PLL, and flexible digital interfaces.

Device Information⁽¹⁾

PART NUMBER	PACKAGE	BODY SIZE (NOM)
TLV320AIC3256	WQFN (40)	5.00 mm x 5.00 mm
	DSBGA (42)	3.49 mm x 3.29 mm

(1) For all available packages, see the orderable addendum at the end of the datasheet.

4 Simplified Block Diagram

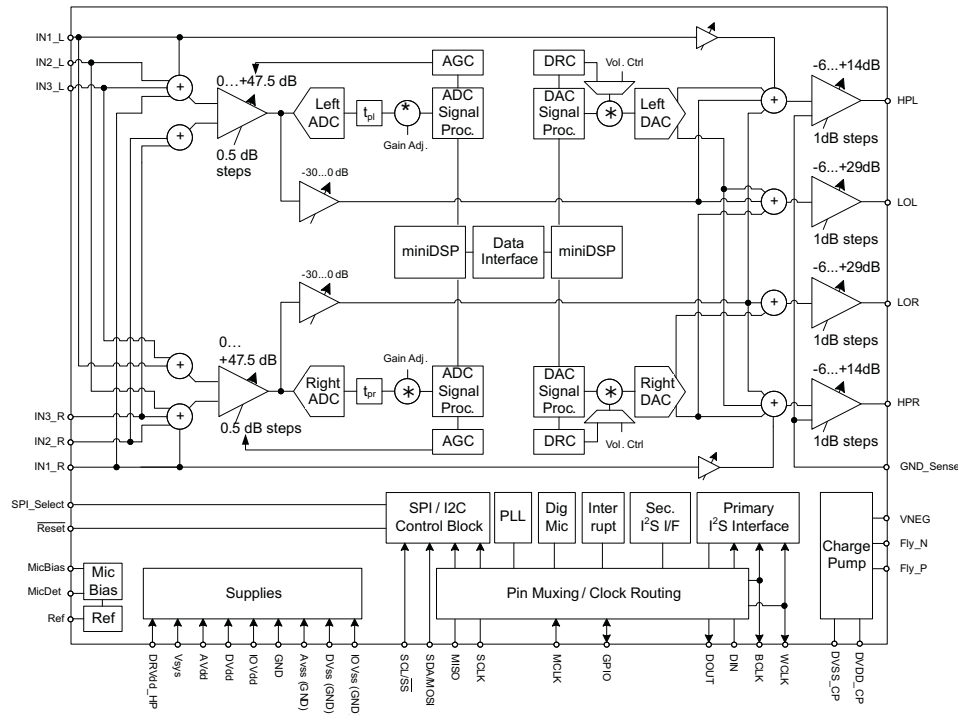

Table of Contents

1 Features	1	8.16 I ² C Interface Timing	20
2 Applications	1	8.17 SPI Interface Timing	21
3 Description	1	8.18 Typical Characteristics	22
4 Simplified Block Diagram	1	9 Parameter Measurement Information	24
5 Revision History	2	10 Detailed Description	24
6 Device Comparison Table	4	10.1 Overview	24
7 Pin Configuration and Functions	5	10.2 Functional Block Diagram	25
8 Specifications	7	10.3 Feature Description.....	25
8.1 Absolute Maximum Ratings	7	10.4 Device Functional Modes.....	32
8.2 Handling Ratings.....	8	10.5 Register Map.....	33
8.3 Recommended Operating Conditions.....	8	11 Application and Implementation	37
8.4 Thermal Information	9	11.1 Application Information.....	37
8.5 Electrical Characteristics, ADC	9	11.2 Typical Application	37
8.6 Electrical Characteristics, Bypass Outputs	11	12 Power Supply Recommendations	41
8.7 Electrical Characteristics, Microphone Interface.....	12	13 Layout	41
8.8 Electrical Characteristics, Audio DAC Outputs	13	13.1 Layout Guidelines	41
8.9 Electrical Characteristics, Misc.	14	13.2 Layout Example	42
8.10 Electrical Characteristics, Logic Levels.....	15	14 Device and Documentation Support	43
8.11 I ² S/LJF/RJF Timing in Master Mode (see Figure 1).....	15	14.1 Documentation Support	43
8.12 I ² S/LJF/RJF Timing in Slave Mode (see Figure 2).....	16	14.2 Trademarks	43
8.13 DSP Timing in Master Mode (see Figure 3)	17	14.3 Electrostatic Discharge Caution.....	43
8.14 DSP Timing in Slave Mode (see Figure 4)	18	14.4 Glossary	43
8.15 Digital Microphone PDM Timing (see Figure 5)....	19	15 Mechanical, Packaging, and Orderable Information	43

5 Revision History

NOTE: Page numbers for previous revisions may differ from page numbers in the current version.

Changes from Revision B (January 2013) to Revision C	Page
• Added the Device information table, Handling Ratings table, Applications and Implementation section, Layout section, and the Device and Documentation Support section.....	1
• Deleted "Acoustic Echo Cancellation (AEC)" and "Active Noise Cancellation (ANC)" from applications list.....	1
• Added Note 1 to the Pin Functions table.....	5
• Added "Audio input mux ac signal swing" to the Recommended Operating Conditions table	8
• Added the Digital Microphone PDM Timing (see Figure 5) section	19

Changes from Revision A (December 2010) to Revision B	Page
• Added WCSP package (YZF).....	1
• Updated block diagram to include V _{sys} pin	1
• Updated diagram to include V _{sys} pin.....	37
• Updated power supply section to include V _{sys}	41

Changes from Original (December 2010) to Revision A
Page

• Changed "mV" to "mVRMS" for Input signal level units	10
• Changed Gain Error value from 0.7 to 0.8	11
• Changed Gain Error value from 0.5 to 0.8	11
• Changed Noise, Idle Channel value from 6.9 to 6.7	11
• Changed Bias voltage, Micbias Mode 0 value from 1.25 to 1.23.....	12
• Changed Bias voltage, Micbias Mode 0 value from 1.25 to 1.23.....	12
• Changed DAC Gain Error value from 0.4 to 0.5.....	13
• Changed DAC Gain Error value from 0.1 to 0.5.....	14
• Changed DAC channel separation condition from –1dB to –3dB	14
• Changed 10µF to 1µF in Reference Noise conditions statement	14
• Deleted min value from Decoupling Capacitor, changed typ value from 10 to 1µF	14
• Moved value from typ to min	14
• Moved value from typ to min	14
• Changed WCLK delay min from 14 to 30ns.....	15

6 Device Comparison Table

PART NUMBER	DESCRIPTION
TLV320AIC3254	Low power stereo audio codec with miniDSP.
TLV320AIC3204	Same as TLV320AIC3204 but without miniDSP.
TLV320AIC3256	Similar to TLV320AIC3254 but with ground centered headphone output.
TLV320AIC3206	Same as TLV320AIC3256 but without miniDSP.

7 Pin Configuration and Functions

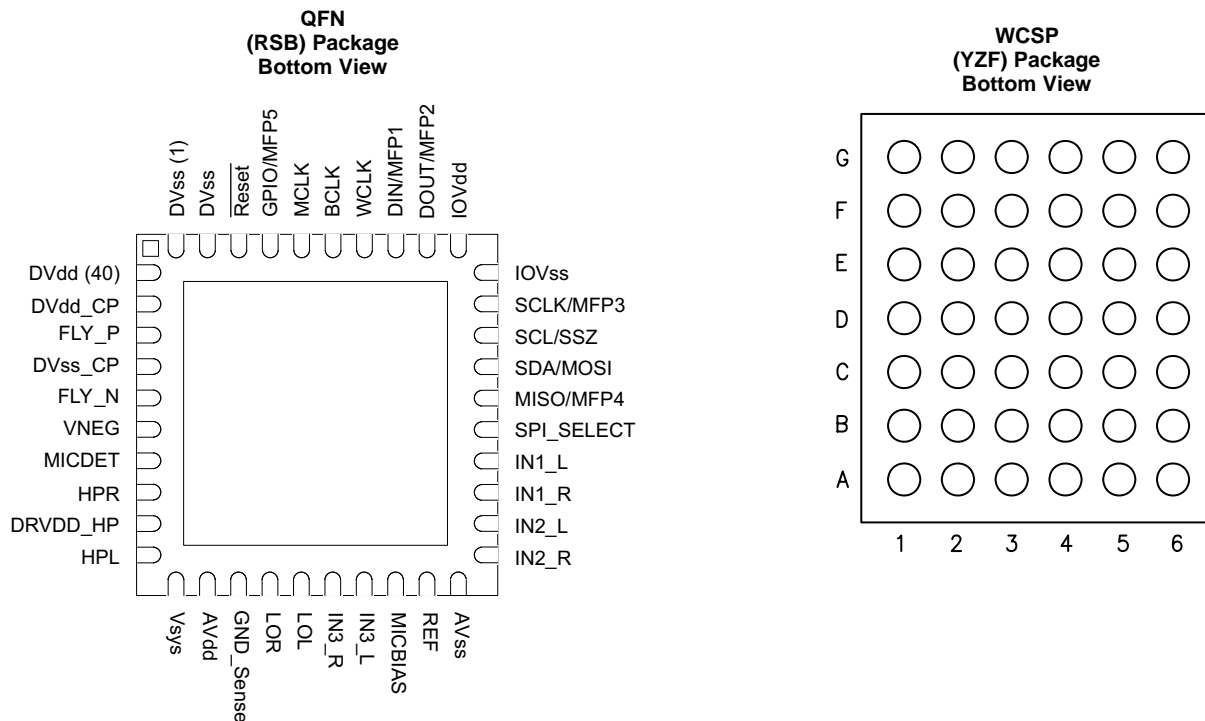

Pin Functions

PIN		WCSP (YZF) BALL NO.	TYPE ⁽¹⁾	DESCRIPTION
NAME	QFN (RSB) NO.			
DVss	1	B2	GND	Digital ground. Device substrate.
DVss	2	A1	GND	Digital ground
$\overline{\text{RESET}}$	3	C5	DI	Hardware reset
GPIO MFP5	4	B3	DI/O	Primary function: General purpose digital IO Secondary function: CLKOUT output INT1 output INT2 output Audio serial data bus ADC word clock output Audio serial data bus (secondary) bit clock output Audio serial data bus (secondary) word clock output Digital microphone clock output
MCLK	5	A2	DI	Master clock input
BCLK	6	B4	DI/O	Audio serial data bus (primary) bit clock
WCLK	7	A3	DI/O	Audio serial data bus (primary) word clock
DIN MFP1	8	A5	DI	Primary function: Audio serial data bus data input Secondary function: Digital Microphone Input General Purpose Clock Input General Purpose Input
DOUT	9	A4	DO	Primary function:

(1) DI (Digital Input), DO (Digital Output), DIO (Digital Input/Output), AI (Analog Input), AO (Analog Output), AIO (Analog Input/Output)

Pin Functions (continued)

PIN		WCSP (YZF) BALL NO.	TYPE ⁽¹⁾	DESCRIPTION
NAME	QFN (RSB) NO.			
MFP2				Audio serial data bus data output Secondary function: General purpose output Clock output INT1 output INT2 output Audio serial data bus (secondary) bit clock output Audio serial data bus (secondary) word clock output
IOVdd	10	A6	PWR	Supply for IO buffers. 1.1V to 3.6V
IOVss	11	B5	GND	Ground for IO buffers.
SCLK MFP3	12	C4	DI	Primary function: (SPI_Select = 1) SPI serial clock Secondary function:: (SPI_Select = 0) Digital microphone input Audio serial data bus (secondary) bit clock input Audio serial data bus (secondary) DAC/common word clock input Audio serial data bus (secondary) ADC word clock input Audio serial data bus (secondary) data input General purpose input
SCL SS	13	B6	DI	I ² C interface serial clock (SPI_Select = 0) SPI interface mode chip-select signal (SPI_Select = 1)
SDA MOSI	14	C3	DI/O	I ² C interface mode serial data input (SPI_Select = 0) SPI interface mode serial data input (SPI_Select = 1)
MISO MFP4	15	D4	DO	Primary function: (SPI_Select = 1) Serial data output Secondary function: (SPI_Select = 0) General purpose output CLKOUT output INT1 output INT2 output Audio serial data bus (primary) ADC word clock output Digital microphone clock output Audio serial data bus (secondary) data output Audio serial data bus (secondary) bit clock output Audio serial data bus (secondary) word clock output
SPI_SELECT	16	C6	DI	Control mode select pin (1 = SPI, 0 = I ² C)
IN1_L	17	D6	AI	Multifunction analog input, Single-ended configuration: MIC 1 or Line 1 left Differential configuration: MIC or Line right, negative
IN1_R	18	E6	AI	Multifunction analog input, Single-ended configuration: MIC 1 or Line 1 right Differential configuration: MIC or Line right, positive
IN2_L	19	F6	AI	Multifunction analog input, Single-ended configuration: MIC 2 or Line 2 right Differential configuration: MIC or Line left, positive
IN2_R	20	G6	AI	Multifunction analog input, Single-ended configuration: MIC 2 or Line 2 right Differential configuration: MIC or Line left, negative
AVss	21	E4, E5	GND	Analog Ground
REF	22	G5	AO	Reference voltage output for filtering
MICBIAS	23	G4	AO	Microphone bias voltage output

Pin Functions (continued)

PIN		WCSP (YZF) BALL NO.	TYPE ⁽¹⁾	DESCRIPTION
NAME	QFN (RSB) NO.			
IN3_L	24	F5	AI	Multifunction analog input, Single-ended configuration: MIC3 or Line 3 left, Differential configuration: MIC or Line left, positive, Differential configuration: MIC or Line right, negative
IN3_R	25	F4	AI	Multifunction analog input, Single-ended configuration: MIC3 or Line 3 right, Differential configuration: MIC or Line left, negative, Differential configuration: MIC or Line right, positive
LOL	26	G3	AO	Left line output
LOR	27	F3	AO	Right line output
GND_SENSE	28	E3	AI	External ground reference for headphone interface –0.5V to 0.5V
AVdd	29	G2	PWR	Analog voltage supply 1.5V–1.95V
Vsys	30	G1	PWR	Power supply 1.5V–5.5V, Vsys must always be greater than or equal to AVdd and DVdd (Vsys ≥ AVdd, DVdd)
HPL	31	F1	AO	Left headphone output
DRVdd_HP	32	F2	PWR	Power supply for headphone output stage Ground-centered circuit configuration, 1.5V to 1.95V Unipolar circuit configuration, 1.5V to 3.6V
HPR	33	E1	AO	Right headphone output
MICDET	34	E2	AI	Microphone detection
VNEG	35	D1	PWR	Negative supply for headphones. –1.8V to 0V Input when charge pump is disabled, Filtering output when charge pump is enabled
FLY_N	36	D2	PWR	Negative terminal for charge-pump flying capacitor
DVss_CP	37	D3	GND	Charge pump ground
FLY_P	38	C2	PWR	Positive terminal for charge pump flying capacitor
DVdd_CP	39	C1	PWR	Charge Pump supply; recommended to connect to DVdd
DVdd	40	B1	PWR	Digital voltage supply 1.26V – 1.95V
Thermal Pad	Thermal Pad	N/A	N/A	Connect to PCB ground plane. Not internally connected.

8 Specifications

8.1 Absolute Maximum Ratings

over operating free-air temperature range (unless otherwise noted) ⁽¹⁾

	MIN	MAX	UNIT
AVdd to AVss	–0.3	2.2	V
DVdd to DVss	–0.3	2.2	V
Vsys to DVss	–0.3	5.5	V
IOVdd to IOVss	–0.3	3.9	V
Digital Input voltage	IOVss	IOVdd + 0.3	V
Analog input voltage	AVss	AVdd + 0.3	V
Operating temperature range	–40	85	°C
Junction temperature (T _J Max)		105	°C

- (1) Stresses beyond those listed under Absolute Maximum Ratings may cause permanent damage to the device. These are stress ratings only, and functional operation of the device at these or any other conditions beyond those indicated under *Recommended Operating Conditions* is not implied. Exposure to absolute-maximum-rated conditions for extended periods may affect device reliability.

8.2 Handling Ratings

			MIN	MAX	UNIT
T _{stg}	Storage temperature range		-55	125	°C
V _(ESD)	Electrostatic discharge	Human body model (HBM), per ANSI/ESDA/JEDEC JS-001, all pins ⁽¹⁾	-2	2	kV
		Charged device model (CDM), per JEDEC specification JESD22-C101, all pins ⁽²⁾	-750	750	V

(1) JEDEC document JEP155 states that 500-V HBM allows safe manufacturing with a standard ESD control process.

(2) JEDEC document JEP157 states that 250-V CDM allows safe manufacturing with a standard ESD control process.

8.3 Recommended Operating Conditions

			MIN	NOM	MAX	UNIT
AV _{DD}	Power Supply Voltage Range	Referenced to AV _{SS} ⁽¹⁾	1.5	1.8	1.95	V
IOV _{DD}		Referenced to IOV _{SS} ⁽¹⁾	1.1		3.6	
V _{sys}		Referenced to DV _{SS} ⁽¹⁾	1.5	1.8	5.5	
DV _{dd} ⁽²⁾		Referenced to DV _{SS} ⁽¹⁾	1.26	1.8	1.95	
DV _{DD_CP}	Power Supply Voltage Range	Referenced to DV _{SS} ⁽¹⁾	1.26	1.8	1.95	V
D _{RVDD_HP}		Referenced to AV _{SS} ⁽¹⁾	Ground-centered config	1.5	1.8	
			Unipolar config	1.5		3.6
PLL Input Frequency	Clock divider uses fractional divide (D > 0), P = 1, DV _{dd} ≥ 1.65V (See table in SLAU306, <i>Maximum TLV320AIC3256 Clock Frequencies</i>)		10		20	MHz
	Clock divider uses integer divide (D = 0), P = 1, DV _{dd} ≥ 1.65V (See table in SLAU306, <i>Maximum TLV320AIC3256 Clock Frequencies</i>)		0.512		20	MHz
MCLK	Master Clock Frequency	MCLK; Master Clock Frequency; DV _{dd} ≥ 1.65V			50	MHz
		MCLK; Master Clock Frequency; DV _{dd} ≥ 1.26V			25	
SCL	SCL Clock Frequency			400	kHz	
Audio input max ac signal swing (IN1_L, IN1_R, IN2_L, IN2_R, IN3_L, IN3_R)	CM = 0.75 V		0	0.530	0.75 or AV _{DD} - 0.75 ⁽³⁾	V _{peak}
	CM = 0.9 V		0	0.707	0.9 or AV _{DD} - 0.9 ⁽³⁾	V _{peak}
LOL, LOR	Stereo line output load resistance		0.6	10		kΩ
HPL, HPR	Stereo headphone output load resistance	Single-ended configuration	14.4	16		Ω
	Headphone output load resistance	Differential configuration	24.4	32		Ω
C _{Lout}	Digital output load capacitance			10		pF
TOPR	Operating Temperature Range		-40		85	°C

(1) All grounds on board are tied together; they must not differ in voltage by more than 0.2V max, for any combination of ground signals.

(2) At DV_{dd} values lower than 1.65V, the PLL does not function. Please see table in SLAU306, *Maximum TLV320AIC3256 Clock Frequencies* for details on maximum clock frequencies.

(3) Whichever is smaller

8.4 Thermal Information

THERMAL METRIC ⁽¹⁾		TLV320AIC3256		UNIT
		RSB (QFN)	YZF (DSGBA)	
		48 PINS	42 PINS	
R _{θJA}	Junction-to-ambient thermal resistance	32.3	49.7	°C/W
R _{θJctop}	Junction-to-case (top) thermal resistance	22.5	0.1	
R _{θJB}	Junction-to-board thermal resistance	6.1	7.7	
ψ _{JT}	Junction-to-top characterization parameter	0.3	0.1	
ψ _{JB}	Junction-to-board characterization parameter	6	7.7	
R _{θJcbot}	Junction-to-case (bottom) thermal resistance	1.7	–	

(1) For more information about traditional and new thermal metrics, see the *IC Package Thermal Metrics* application report, [SPRA953](#).

8.5 Electrical Characteristics, ADC

At 25°C, V_{sys}, AV_{dd}, DV_{dd}, IOV_{dd}, DV_{dd_CP}, DRV_{dd_HP} = 1.8V, f_S (Audio) = 48kHz, C_{REF} = 1μF on REF PIN, PLL and Charge pump disabled unless otherwise noted.

PARAMETER		TEST CONDITIONS	MIN	TYP	MAX	UNIT
AUDIO ADC (CM = 0.9V)						
Input signal level (for 0dB output)		Single-ended, CM = 0.9V	0.5			V _{RMS}
Device Setup		1kHz sine wave input Single-ended Configuration IN1_R to Right ADC and IN1_L to Left ADC, R _{IN} = 20kΩ, f _S = 48kHz, AOSR = 128, MCLK = 256 * f _S , PLL Disabled; AGC = OFF, Channel Gain = 0dB, Processing Block = PRB_R1, Power Tune = PTM_R4				
SNR	Signal-to-noise ratio, A-weighted ^{(1) (2)}	Inputs ac-shortened to ground	80	93		dB
		IN2_R, IN3_R routed to Right ADC and ac-shortened to ground IN2_L, IN3_L routed to Left ADC and ac-shortened to ground	93			
DR	Dynamic range A-weighted ^{(1) (2)}	–60dB full-scale, 1kHz input signal	93			dB
THD+N	Total Harmonic Distortion plus Noise	–3dB full-scale, 1kHz input signal	–84	–70		dB
		IN2_R, IN3_R routed to Right ADC IN2_L, IN3_L routed to Left ADC –3dB full-scale, 1kHz input signal	–84			
AUDIO ADC (CM = 0.75V)						
Input signal level (for 0dB output)		Single-ended, CM = 0.75V, AV _{dd} = 1.5V	0.375			V _{RMS}
Device Setup:		1kHz sine wave input Single-ended Configuration INR, IN2_R, IN3_R routed to Right ADC INL, IN2_L, IN3_L routed to Left ADC R _{IN} = 20kΩ, f _S = 48kHz, AOSR = 128, MCLK = 256 * f _S , PLL Disabled, AGC = OFF, Channel Gain = 0dB, Processing Block = PRB_R1 Power Tune = PTM_R4				
SNR	Signal-to-noise ratio, A-weighted ^{(1) (2)}	Inputs ac-shortened to ground	90			dB

(1) Ratio of output level with 1kHz full-scale sine wave input, to the output level with the inputs short circuited, measured A-weighted over a 20Hz to 20kHz bandwidth using an audio analyzer.

(2) All performance measurements done with 20kHz low-pass filter and, where noted, A-weighted filter. Failure to use such a filter may result in higher THD+N and lower SNR and dynamic range readings than shown in the Electrical Characteristics. The low-pass filter removes out-of-band noise, which, although not audible, may affect dynamic specification values

Electrical Characteristics, ADC (continued)

At 25°C, V_{sys}, AV_{dd}, DV_{dd}, IOV_{dd}, DV_{dd_CP}, DRV_{dd_HP} = 1.8V, f_s (Audio) = 48kHz, C_{REF} = 1μF on REF PIN, PLL and Charge pump disabled unless otherwise noted.

PARAMETER		TEST CONDITIONS	MIN	TYP	MAX	UNIT
DR	Dynamic range A-weighted ⁽¹⁾ ⁽²⁾	–60dB full-scale, 1kHz input signal		90		dB
THD+N	Total Harmonic Distortion plus Noise	–3dB full-scale, 1kHz input signal		–81		dB
AUDIO ADC (Gain = 40dB)						
	Input signal level (for 0dB output)	Differential Input, CM = 0.9V, Channel Gain = 40dB		10		mV _{RMS}
	Device Setup	1kHz sine wave input Differential configuration IN1_L and IN1_R routed to Right ADC IN2_L and IN2_R routed to Left ADC R _{IN} = 10kΩ, f _s = 48kHz, AOSR = 128 MCLK = 256 * f _s PLL Disabled AGC = OFF Processing Block = PRB_R1, Power Tune = PTM_R4				
ICN	Idle-Channel Noise, A-weighted ⁽¹⁾ ⁽²⁾	Inputs ac-shorted to ground, input referred noise		2.8		μV _{RMS}
AUDIO ADC						
	Gain Error	1kHz sine wave input Single-ended configuration R _{IN} = 20kΩ, f _s = 48kHz, AOSR = 128, MCLK = 256 * f _s , PLL Disabled AGC = OFF, Channel Gain = 0dB Processing Block = PRB_R1, Power Tune = PTM_R4, CM = 0.9V		0.1		dB
	Input Channel Separation	1kHz sine wave input at –3dBFS Single-ended configuration IN1_L routed to Left ADC IN1_R routed to Right ADC, R _{IN} = 20kΩ AGC = OFF, AOSR = 128, Channel Gain = 0dB, CM = 0.9V		109		dB
	Input Pin Crosstalk	1kHz sine wave input at –3dBFS on IN2_L, IN2_L internally not routed. IN1_L routed to Left ADC ac-coupled to ground 1kHz sine wave input at –3dBFS on IN2_R, IN2_R internally not routed. IN1_R routed to Right ADC ac-coupled to ground Single-ended configuration R _{IN} = 20kΩ, AOSR = 128 Channel, Gain = 0dB, CM = 0.9V		108		dB
	PSRR	217Hz, 100mVpp signal on AV _{dd} , Single-ended configuration, R _{IN} = 20kΩ, Channel Gain = 0dB; CM = 0.9V		55		dB
	ADC programmable gain amplifier gain	Single-Ended, R _{IN} = 10kΩ, PGA gain set to 0dB		0		dB
		Single-Ended, R _{IN} = 10kΩ, PGA gain set to 47.5dB		47.5		dB
		Single-Ended, R _{IN} = 20kΩ, PGA gain set to 0dB		–6		dB
		Single-Ended, R _{IN} = 20kΩ, PGA gain set to 47.5dB		41.5		dB
		Single-Ended, R _{IN} = 40kΩ, PGA gain set to 0dB		–12		dB
		Single-Ended, R _{IN} = 40kΩ, PGA gain set to 47.5dB		35.5		dB
	ADC programmable gain amplifier step size	1kHz tone		0.5		dB

8.6 Electrical Characteristics, Bypass Outputs

At 25°C, V_{sys}, AV_{dd}, DV_{dd}, IOV_{dd}, DV_{dd_CP}, DRV_{dd_HP} = 1.8V, f_s (Audio) = 48kHz, C_{REF} = 1μF on REF PIN, PLL and Charge pump disabled unless otherwise noted.

PARAMETER		TEST CONDITIONS	MIN	TYP	MAX	UNIT
ANALOG BYPASS TO HEADPHONE AMPLIFIER, DIRECT MODE						
Device Setup		Load = 16Ω (single-ended), 50pF; Input and Output CM = 0.9V; Headphone Output on DRV _{dd_HP} Supply; IN1_L routed to HPL and IN1_R routed to HPR; Channel Gain = 0dB				
Gain Error				0.8		dB
Noise, A-weighted ⁽¹⁾		Idle Channel, IN1_L and IN1_R ac-shortcd to ground		3.3		μV _{RMS}
THD	Total Harmonic Distortion	446mV _{rms} , 1kHz input signal		-81		dB
ANALOG BYPASS TO LINE-OUT AMPLIFIER, PGA MODE						
Device Setup		Load = 10kΩ (single-ended), 50pF; Input and Output CM = 0.9V; LINE Output on DRV _{DD_HP} Supply; IN1_L, IN1_R routed to line out Channel Gain = 0dB				
Gain Error Gain Error				0.8		dB
Noise, A-weighted ⁽¹⁾		Idle Channel, IN1_L and IN1_R ac-shortcd to ground		6.7		μV _{RMS}
		Channel Gain = 40dB, Input Signal (0dB) = 5mV _{RMS} Inputs ac-shortcd to ground, Input Referred		3		μV _{RMS}

(1) All performance measurements done with 20kHz low-pass filter and, where noted, A-weighted filter. Failure to use such a filter may result in higher THD+N and lower SNR and dynamic range readings than shown in the Electrical Characteristics. The low-pass filter removes out-of-band noise, which, although not audible, may affect dynamic specification values

8.7 Electrical Characteristics, Microphone Interface

At 25°C, V_{sys}, AV_{dd}, DV_{dd}, IOV_{dd}, DV_{dd_CP}, DRV_{dd_HP} = 1.8V, f_s (Audio) = 48kHz, C_{REF} = 1μF on REF PIN, PLL and Charge pump disabled unless otherwise noted.

PARAMETER	TEST CONDITIONS	MIN	TYP	MAX	UNIT
MICROPHONE BIAS					
Bias voltage	<i>Bias voltage CM = 0.9V, DRV_{dd_HP} = 1.8V</i>				
	Micbias Mode 0, Connect to AV _{dd} or DRV _{dd_HP}		1.5		V
	Micbias Mode 3, Connect to AV _{dd}		AV _{dd}		V
	Micbias Mode 3, Connect to DRV _{dd_HP}		DRV _{dd_HP}		V
	<i>CM = 0.75V, DRV_{dd_HP} = 1.8V</i>				
	Micbias Mode 0, Connect to AV _{dd} or DRV _{dd_HP}		1.23		V
	Micbias Mode 1, Connect to AV _{dd} or DRV _{dd_HP}		1.43		V
	Micbias Mode 3, Connect to AV _{dd}		AV _{dd}		V
Micbias Mode 3, Connect to DRV _{dd_HP}		DRV _{dd_HP}		V	
MICROPHONE BIAS					
Bias voltage	<i>Bias voltage CM = 0.9V, DRV_{dd_HP} = 3.3V</i>				
	Micbias Mode 0, Connect to DRV _{dd_HP}		1.5		V
	Micbias Mode 1, Connect to DRV _{dd_HP}		1.7		V
	Micbias Mode 2, Connect to DRV _{dd_HP}		2.5		V
	Micbias Mode 3, Connect to DRV _{dd_HP}		DRV _{dd_HP}		V
	<i>CM = 0.75V, DRV_{dd_HP} = 3.3V</i>				
	Micbias Mode 0, Connect to DRV _{dd_HP}		1.23		V
	Micbias Mode 1, Connect to DRV _{dd_HP}		1.43		V
	Micbias Mode 2, Connect to DRV _{dd_HP}		2.1		V
	Micbias Mode 3, Connect to DRV _{dd_HP}		DRV _{dd_HP}		V
Output Noise	CM = 0.9V, Micbias Mode 2, A-weighted, 20Hz to 20kHz bandwidth, Current load = 0mA.		9.5		μV _{RMS}
Current Sourcing	Micbias Mode 2, Connect to DRV _{dd_HP}		3		mA
Inline Resistance	Micbias Mode 3, Connect to AV _{dd}		131		Ω
	Micbias Mode 3, Connect to DRV _{dd_HP}		89		

8.8 Electrical Characteristics, Audio DAC Outputs

At 25°C, V_{sys}, AV_{dd}, DV_{dd}, IOV_{dd}, DV_{dd_CP}, DRV_{dd_HP} = 1.8V, f_s (Audio) = 48kHz, C_{REF} = 1μF on REF PIN, PLL and Charge pump disabled unless otherwise noted.

PARAMETER		TEST CONDITIONS	MIN	TYP	MAX	UNIT
AUDIO DAC – STEREO SINGLE-ENDED LINE OUTPUT (CM = 0.9V)						
Device Setup		Load = 10kΩ (single-ended), 56pF Line Output on AV _{dd} Supply Input and Output CM=0.9V DOSR = 128, MCLK = 256 x f _s , Channel Gain = 0dB, word length = 16 bits, Processing Block = PRB_P1, Power Tune = PTM_P3				
Full scale output voltage (0dB)				0.5		V _{RMS}
SNR	Signal-to-noise ratio A-weighted ^{(1) (2)}	All zeros fed to DAC input	87	100		dB
DR	Dynamic range, A-weighted ^{(1) (2)}	–60dB 1kHz input full-scale signal, Word length = 20 bits		100		dB
THD+N	Total Harmonic Distortion plus Noise	–3dB full-scale, 1kHz input signal		–81	–70	dB
DAC Gain Error		0dB, 1kHz input full scale signal		0.5		dB
DAC Mute Attenuation		Mute		121		dB
DAC channel separation		–1dB, 1kHz signal, between left and right HP out		108		dB
DAC PSRR		100mV _{pp} , 1kHz signal applied to AV _{dd}		72		dB
		100mV _{pp} , 217Hz signal applied to AV _{dd}		80		dB
AUDIO DAC – STEREO SINGLE-ENDED LINE OUTPUT (CM = 0.75V)						
Device Setup		Load = 10kΩ (single-ended), 56pF Line Output on AV _{dd} Supply Input and Output CM = 0.75V; AV _{dd} = 1.5V DOSR = 128 MCLK=256 x f _s Channel Gain = 0dB word length = 20-bits Processing Block = PRB_P1 Power Tune = PTM_P4				
Full scale output voltage (0dB)				0.375		V _{RMS}
SNR	Signal-to-noise ratio, A-weighted ^{(1) (2)}	All zeros fed to DAC input		99		dB
DR	Dynamic range, A-weighted ^{(1) (2)}	–60dB 1kHz input full-scale signal		98		dB
THD+N	Total Harmonic Distortion plus Noise	–1dB full-scale, 1kHz input signal		–77		dB
AUDIO DAC – STEREO SINGLE-ENDED HEADPHONE OUTPUT (GROUND-CENTERED CIRCUIT CONFIGURATION)						
Device Setup		Load = 16Ω (single-ended), 56pF Input CM = 0.9V, Output CM = 0V DOSR = 128, MCLK = 256x* f _s , Channel Gain = 0dB word length = 16 bits; Processing Block = PRB_P1 Power Tune = PTM_P3				
FS1	Full scale output voltage (for THD ≤ –40dB)			0.65		V _{RMS}
SNR	Signal-to-noise ratio, A-weighted ^{(1) (2)}	All zeros fed to DAC input	85	95		dB
DR	Dynamic range, A-weighted ^{(1) (2)}	–60dB 1kHz input full-scale signal, Word Length = 20 bits, Power Tune = PTM_P4		93		dB
THD+N	Total Harmonic Distortion plus Noise	500mV _{RMS} output (corresponds to FS1 – 2.3dB), 1-kHz input signal		–70	–55	dB

- (1) Ratio of output level with 1kHz full-scale sine wave input, to the output level with the inputs short circuited, measured A-weighted over a 20Hz to 20kHz bandwidth using an audio analyzer.
- (2) All performance measured with 20kHz low-pass filter and, where noted, A-weighted filter. Failure to use such a filter may result in higher THD+N and lower SNR and dynamic range readings than shown in the Electrical Characteristics. The low-pass filter removes out-of-band noise, which, although not audible, may affect dynamic specification values.

Electrical Characteristics, Audio DAC Outputs (continued)

At 25°C, V_{sys}, AV_{dd}, DV_{dd}, IOV_{dd}, DV_{dd_CP}, DRV_{dd_HP} = 1.8V, f_s (Audio) = 48kHz, C_{REF} = 1μF on REF PIN, PLL and Charge pump disabled unless otherwise noted.

PARAMETER	TEST CONDITIONS	MIN	TYP	MAX	UNIT
DAC Gain Error	500mV _{RMS} output, 1kHz input full scale signal		0.5		dB
DAC Mute Attenuation	Mute		118		dB
DAC channel separation	-3dB, 1kHz signal, between left and right HP out		102		dB
DAC PSRR	100mV _{pp} , 1kHz signal applied to AV _{dd}		66		dB
	100mV _{pp} , 217Hz signal applied to AV _{dd}		77		dB
Power Delivered	THD ≤ -40dB		26.5		mW
FS2 Full scale output voltage (for THD ≤ -40dB)	Load = 32Ω		0.85		V
SNR Signal-to-noise ratio, A-weighted ^{(1) (2)}	All zeros fed to DAC input, Load = 32Ω		96		dB
Power Delivered	THD ≤ -40dB, Load = 32Ω		22.5		mW
AUDIO DAC – STEREO SINGLE-ENDED HEADPHONE OUTPUT (UNIPOLAR CIRCUIT CONFIGURATION)					
Device Setup	Load = 16Ω (single-ended), 56pF, Headphone Output on AV _{dd} Supply, Input and Output CM = 0.9V, DOSR = 128, MCLK = 256 x f _s , Channel Gain = 0dB, Processing Block = PRB_P1, Power Tune = PTM_P3				
Full scale output voltage (0dB)			0.5		V _{RMS}
SNR Signal-to-noise ratio, A-weighted ^{(1) (2)}	All zeros fed to DAC input	87	100		dB
DR Dynamic range, A-weighted ^{(1) (2)}	-60dB 1kHz input full-scale signal		100		dB
THD+N Total Harmonic Distortion plus Noise	-3dB full-scale, 1kHz input signal		-83	-70	dB

8.9 Electrical Characteristics, Misc.

At 25°C, V_{sys}, AV_{dd}, DV_{dd}, IOV_{dd}, DV_{dd_CP}, DRV_{dd_HP} = 1.8V, f_s (Audio) = 48kHz, C_{REF} = 1μF on REF PIN, PLL and Charge pump disabled unless otherwise noted.

PARAMETER	TEST CONDITIONS	MIN	TYP	MAX	UNIT
REFERENCE					
Reference Voltage Settings	CMM _{Mode} = 0 (0.9V)		0.9		V
	CMM _{Mode} = 1 (0.75V)		0.75		
Reference Noise	CM = 0.9V, A-weighted, 20Hz to 20kHz bandwidth, C _{REF} = 1μF		1.1		μV _{RMS}
Decoupling Capacitor			1		μF
Bias Current			120		μA
miniDSP⁽¹⁾					
Maximum miniDSP clock frequency - ADC	DV _{dd} = 1.65V	58.9			MHz
Maximum miniDSP clock frequency - DAC	DV _{dd} = 1.65V	58.9			MHz
SHUTDOWN CURRENT					
Device Setup	DV _{dd} is provided externally, no clocks supplied, no digital activity, register values are retained				
I _(total)	Sum of all supply currents, all supplies at 1.8V		<10		μA

(1) The miniDSP clock speed is specified by design and not tested in production.

8.10 Electrical Characteristics, Logic Levels⁽¹⁾

At 25°C, AV_{DD}, DV_{DD}, IOV_{DD} = 1.8 V

PARAMETER	TEST CONDITIONS	MIN	TYP	MAX	UNIT
LOGIC FAMILY CMOS					
V _{IH} Logic Level	I _{IH} = 5 μA, IOV _{DD} > 1.6V	0.7 × IOV _{DD}			V
	I _{IH} = 5 μA, 1.2V ≤ IOV _{DD} < 1.6V	0.9 × IOV _{DD}			V
	I _{IH} = 5 μA, IOV _{DD} < 1.2V	IOV _{DD}			V
V _{IL}	I _{IL} = 5 μA, IOV _{DD} > 1.6V	-0.3	0.3 × IOV _{DD}		V
	I _{IL} = 5 μA, 1.2V ≤ IOV _{DD} < 1.6V		0.1 × IOV _{DD}		V
	I _{IL} = 5 μA, IOV _{DD} < 1.2V			0	V
V _{OH}	I _{OH} = 2 TTL loads	0.8 × IOV _{DD}			V
V _{OL}	I _{OL} = 2 TTL loads			0.1 × IOV _{DD}	V
Capacitive Load			10		pF

(1) Applies to all DI, DO, and DIO pins shown in [Pin Configuration and Functions](#)

8.11 I²S/LJF/RJF Timing in Master Mode (see Figure 1)

All specifications at 25°C, DV_{DD} = 1.8 V

		IOVDD=1.8V		IOVDD=3.3V		UNIT
		MIN	MAX	MIN	MAX	
t _{d(WS)}	WCLK delay		30		20	ns
t _{d(DO-WS)}	WCLK to DOUT delay (For LJF Mode only)		20		20	ns
t _{d(DO-BCLK)}	BCLK to DOUT delay		22		20	ns
t _{s(DI)}	DIN setup	8		8		ns
t _{h(DI)}	DIN hold	8		8		ns
t _r	Rise time		24		12	ns
t _f	Fall time		24		12	ns

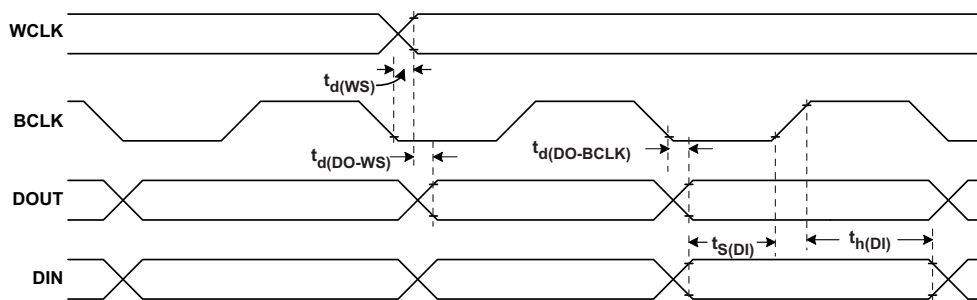
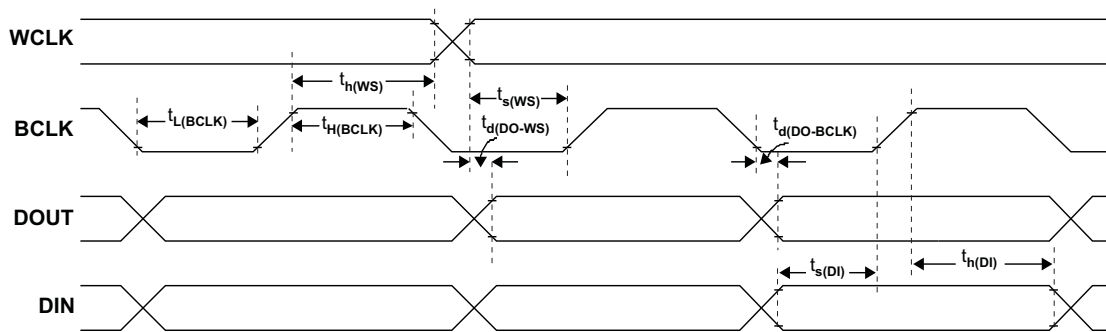

Figure 1. I²S/LJF/RJF Timing in Master Mode

8.12 I²S/LJF/RJF Timing in Slave Mode (see Figure 2)

		IOVDD=1.8V		IOVDD=3.3V		UNIT
		MIN	MAX	MIN	MAX	
$t_{H(BCLK)}$	BCLK high period	35		35		ns
$t_{L(BCLK)}$	BCLK low period	35		35		
$t_{s(WS)}$	WCLK setup	8		8		
$t_{h(WS)}$	WCLK hold	8		8		
$t_{d(DO-WS)}$	WCLK to DOUT delay (For LJF mode only)		20		20	
$t_{d(DO-BCLK)}$	BCLK to DOUT delay		22		22	
$t_{s(DI)}$	DIN setup	8		8		
$t_{h(DI)}$	DIN hold	8		8		
t_r	Rise time		4		4	
t_f	Fall time		4		4	

Figure 2. I²S/LJF/RJF Timing in Slave Mode

8.13 DSP Timing in Master Mode (see Figure 3)

All specifications at 25°C, DVdd = 1.8 V

		IOVDD=1.8V		IOVDD=3.3V		UNIT
		MIN	MAX	MIN	MAX	
$t_{d(WCLK)}$	WCLK delay		30		20	ns
$t_{d(DO-BCLK)}$	BCLK to DOUT delay		22		20	ns
$t_{s(DI)}$	DIN setup	8		8		ns
$t_{h(DI)}$	DIN hold	8		8		ns
t_r	Rise time		24		12	ns
t_f	Fall time		24		12	ns

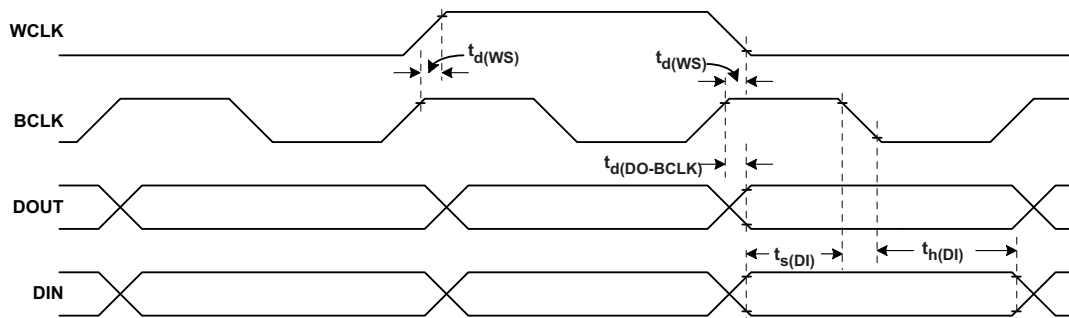

Figure 3. DSP Timing in Master Mode

8.14 DSP Timing in Slave Mode (see [Figure 4](#))

		IOVDD=1.8V		IOVDD=3.3V		UNIT
		MIN	MAX	MIN	MAX	
$t_{H(BCLK)}$	BCLK high period	35		35		ns
$t_{L(BCLK)}$	BCLK low period	35		35		ns
$t_{s(WS)}$	WCLK setup	8		8		ns
$t_{h(WS)}$	WCLK hold	8		8		ns
$t_{d(DO-BCLK)}$	BCLK to DOUT delay		22		22	ns
$t_{s(DI)}$	DIN setup	8		8		ns
$t_{h(DI)}$	DIN hold	8		8		ns
t_r	Rise time		4		4	ns
t_f	Fall time		4		4	ns

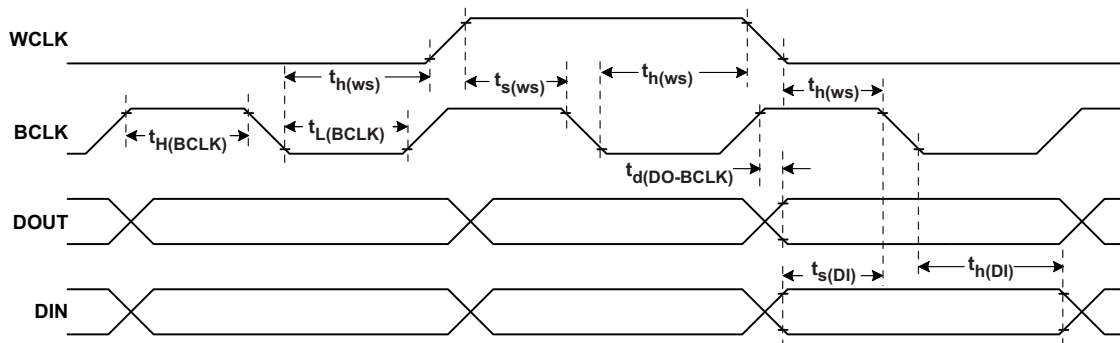

Figure 4. DSP Timing in Slave Mode

8.15 Digital Microphone PDM Timing (see Figure 5)

Based on design simulation. Not tested in actual silicon.

		IOVDD = 1.8V		IOVDD = 3.3V		UNIT
		MIN	MAX	MIN	MAX	
t_s	DIN setup	20		20		ns
t_h	DIN hold	5		5		ns
t_r	Rise time		4		4	ns
t_f	Fall time		4		4	ns

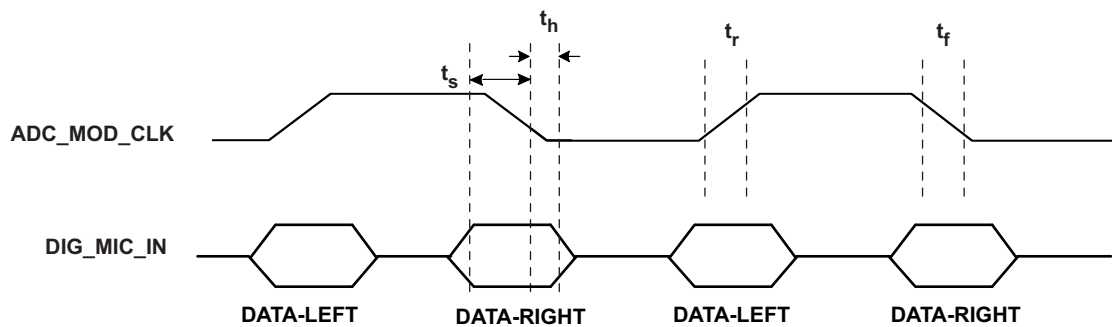

Figure 5. PDM Input Timing

8.16 I²C Interface Timing

		Standard-Mode			Fast-Mode			UNIT
		MIN	TYP	MAX	MIN	TYP	MAX	
f_{SCL}	SCL clock frequency	0		100	0		400	kHz
$t_{H(STA)}$	Hold time (repeated) START condition. After this period, the first clock pulse is generated.	4.0			0.8			μ s
t_{LOW}	LOW period of the SCL clock	4.7			1.3			μ s
t_{HIGH}	HIGH period of the SCL clock	4.0			0.6			μ s
$t_{SU(STA)}$	Setup time for a repeated START condition	4.7			0.8			μ s
$t_{H(DAT)}$	Data hold time: For I2C bus devices	0		3.45	0		0.9	μ s
$t_{SU(DAT)}$	Data set-up time	250			100			ns
t_r	SDA and SCL Rise Time			1000	$20+0.1C_b$		300	ns
t_f	SDA and SCL Fall Time			300	$20+0.1C_b$		300	ns
$t_{SU(STO)}$	Set-up time for STOP condition	4.0			0.8			μ s
t_{BUF}	Bus free time between a STOP and START condition	4.7			1.3			μ s
C_b	Capacitive load for each bus line			400			400	pF

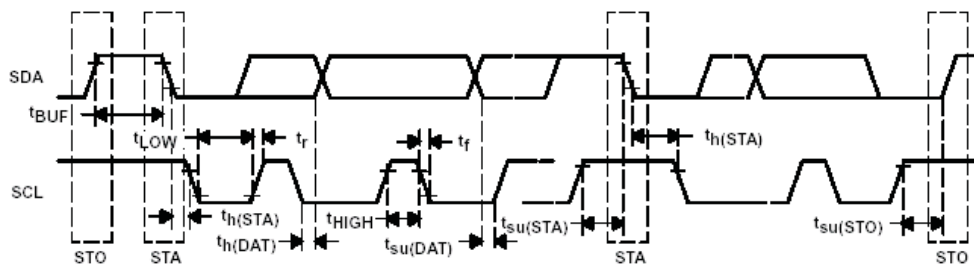
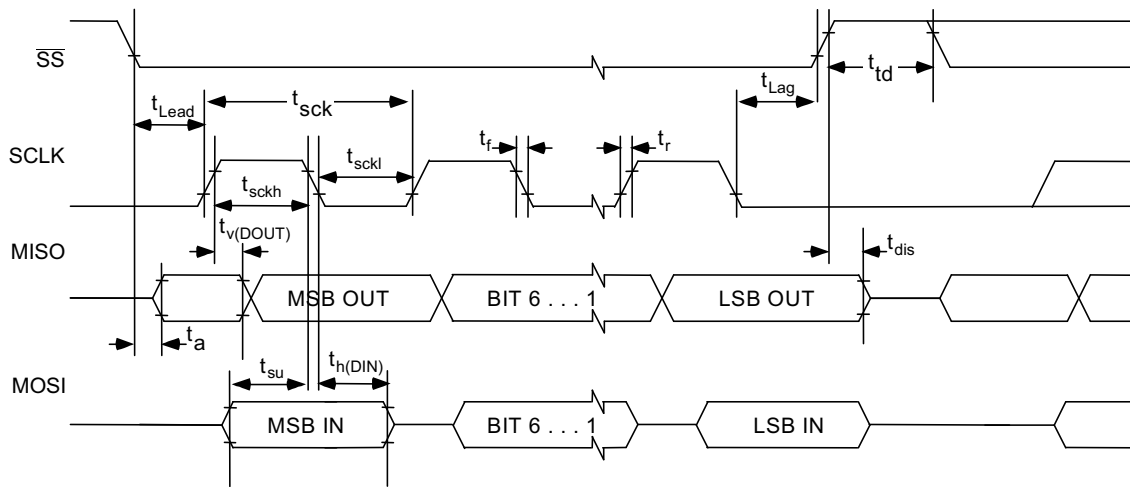

Figure 6. I²C Interface Timing

8.17 SPI Interface Timing

		IOVDD=1.8V			IOVDD=3.3V			UNIT
		MIN	TYP	MAX	MIN	TYP	MAX	
t_{sck}	SCLK Period	100			50			ns
t_{sckh}	SCLK Pulse width High	50			25			ns
t_{sckl}	SCLK Pulse width Low	50			25			ns
t_{lead}	Enable Lead Time	30			20			ns
t_{lag}	Enable Lag Time	30			20			ns
t_d	Sequential Transfer Delay	40			20			ns
t_a	Slave DOUT access time			40			20	ns
t_{dis}	Slave DOUT disable time			40			20	ns
t_{su}	DIN data setup time	15			10			ns
$t_{h(DIN)}$	DIN data hold time	15			10			ns
$t_{v(DOUT)}$	DOUT data valid time			25			18	ns
t_r	SCLK Rise Time			4			4	ns
t_f	SCLK Fall Time			4			4	ns



At 25°C, $D_{VDD} = 1.8\text{ V}$

Figure 7. SPI Interface Timing Diagram

8.18 Typical Characteristics

8.18.1 Typical Performance

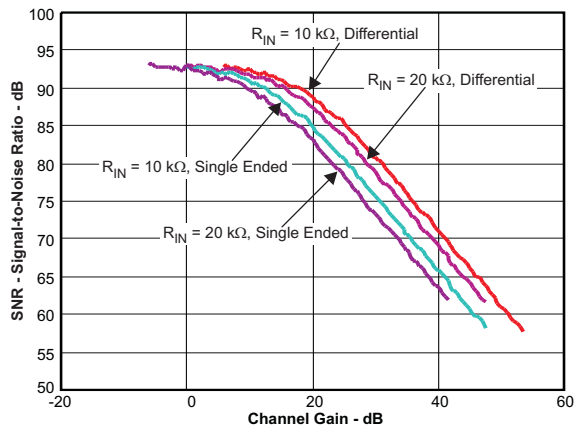

Figure 8. ADC SNR vs Channel Gain

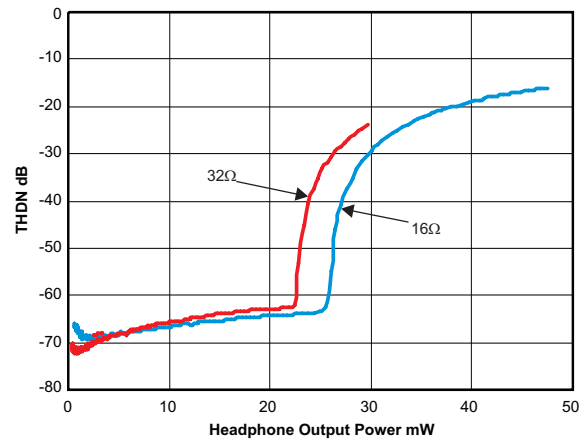

Figure 9. Total Harmonic Distortion GCHP Configuration vs Headphone Output Power

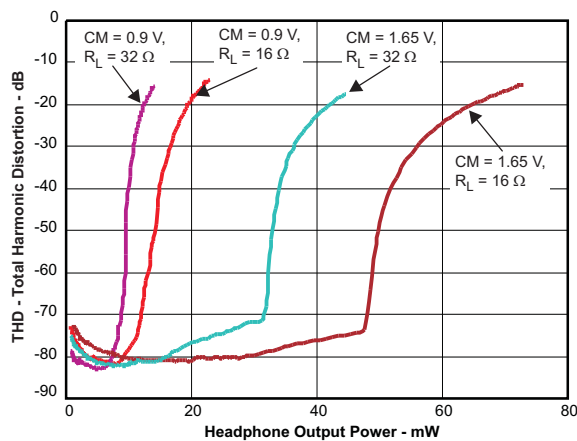

Figure 10. Total Harmonic Distortion Unipolar Configuration vs Headphone Output Power

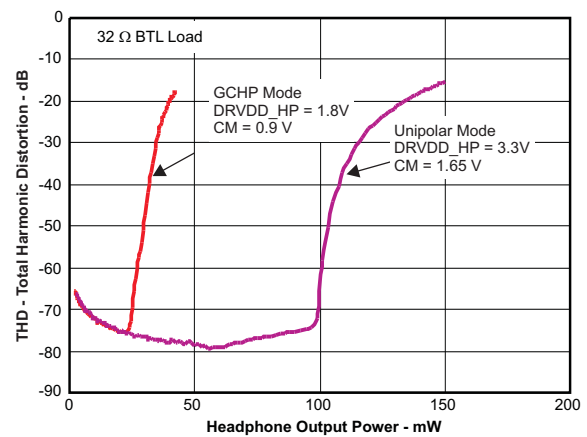

Figure 11. Total Harmonic Distortion vs Headphone Output Power

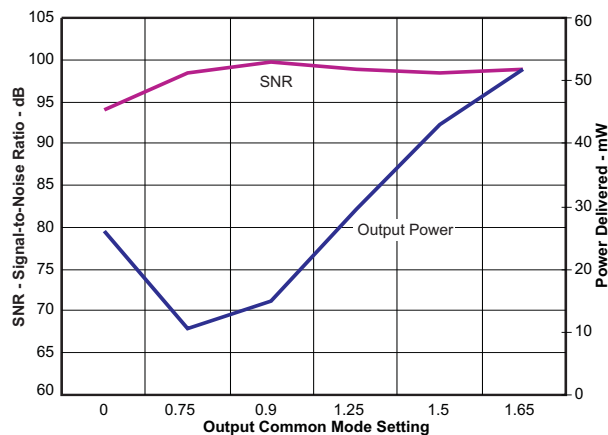
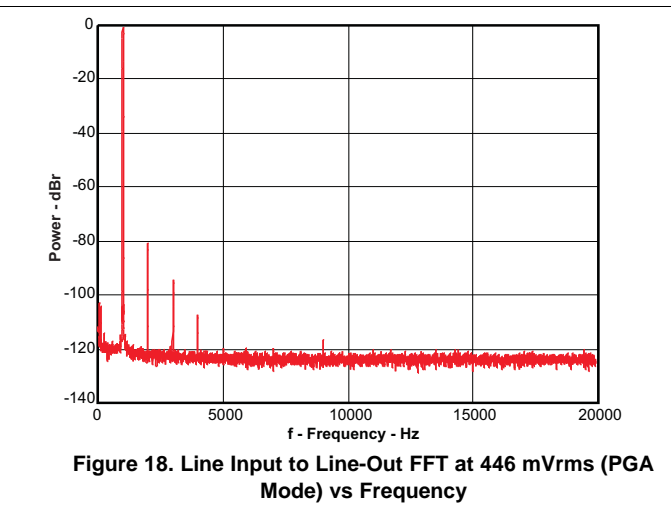
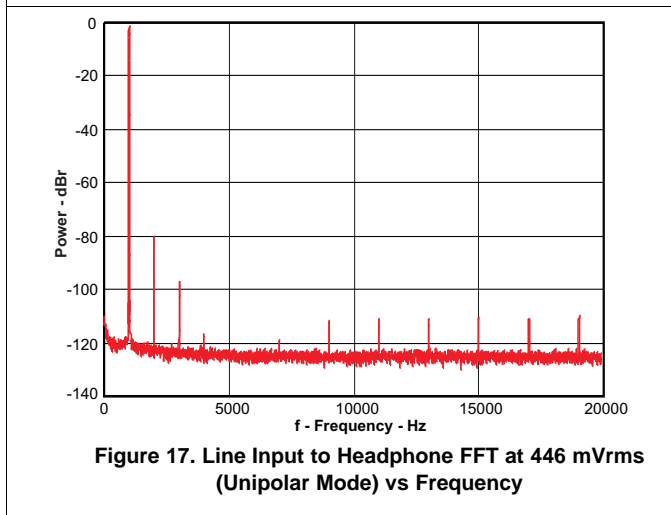
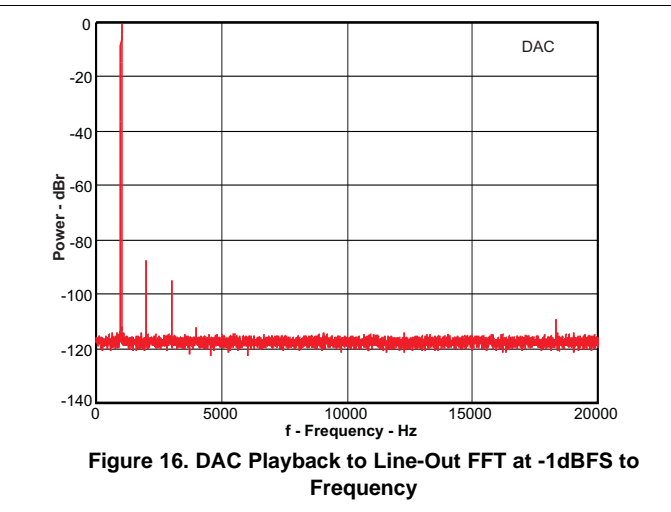
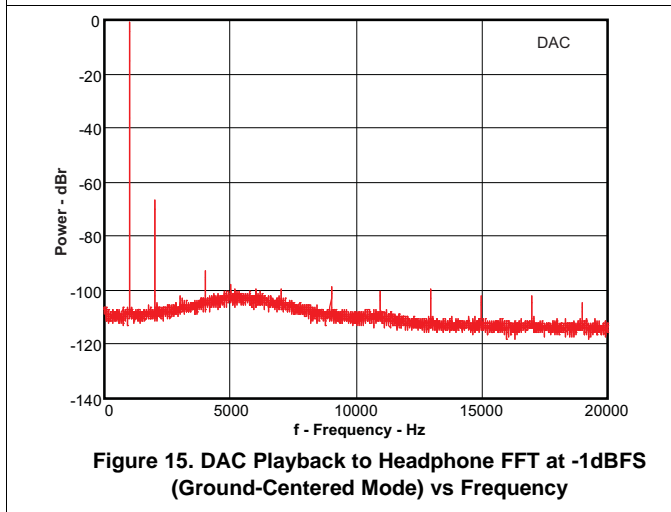
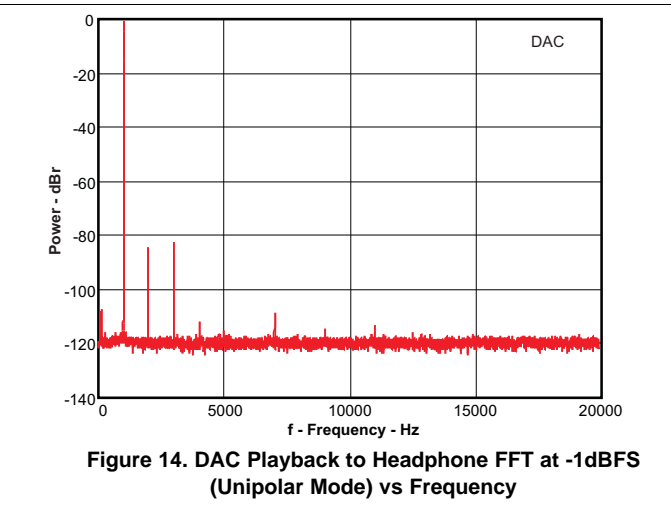
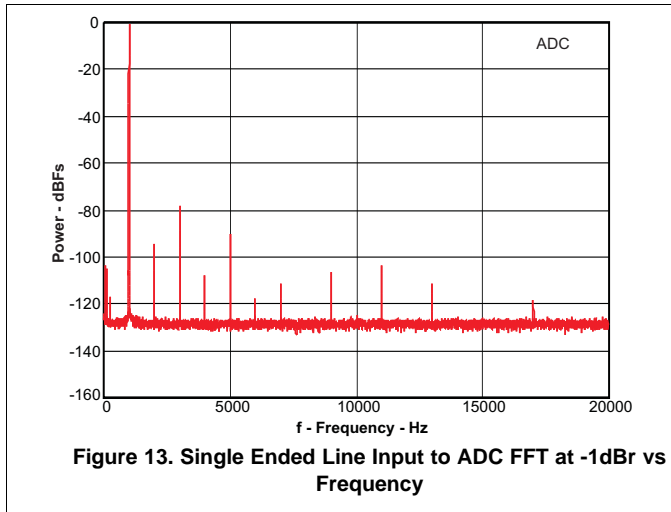

Figure 12. Headphone SNR and Output Power vs Output Common Mode Setting

8.18.2 FFT



9 Parameter Measurement Information

All parameters are measured according to the conditions described in the [Specifications](#) section.

10 Detailed Description

10.1 Overview

The TLV320AIC3256 features two fully-programmable miniDSP cores that support application-specific algorithms in the record and/or the playback path of the device. The miniDSP cores are fully software controlled. Target algorithms are loaded into the device after power-up.

The TLV320AIC3256 includes extensive register-based control of power, input/output channel configuration, gains, effects, pin-multiplexing and clocks, allowing precise targeting of the device to its application. Combined with the advanced PowerTune technology, the device covers operations from 8 kHz mono voice playback to audio stereo 192kHz DAC playback, making it ideal for portable battery-powered audio and telephony applications.

The record path of the TLV320AIC3256 covers operations from 8kHz mono to 192kHz stereo recording, and contains programmable input channel configurations covering single-ended and differential setups, as well as floating or mixing input signals. It also includes a digitally-controlled stereo microphone preamplifier and integrated microphone bias. Digital signal processing blocks can remove audible noise that may be introduced by mechanical coupling, e.g. optical zooming in a digital camera.

The playback path offers signal-processing blocks for filtering and effects, and supports flexible mixing of DAC and analog input signals as well as programmable volume controls. The playback path contains two high-power output drivers which eliminate the need for ac coupling capacitors. A built in charge pump generates the negative supply for the ground centered high powered output drivers. The high-power outputs can be configured in multiple ways, including stereo and mono BTL.

The integrated PowerTune technology allows the device to be tuned to an optimum power-performance trade-off. Mobile applications frequently have multiple use cases requiring very low power operation while being used in a mobile environment. When used in a docked environment power consumption typically is less of a concern, while minimizing noise is important. With PowerTune, the TLV320AIC3256 addresses both cases.

The device offers single supply operation from 1.5V-1.95V. Digital I/O voltages are supported in the range of 1.1V-3.6V.

The required internal clock of the TLV320AIC3256 can be derived from multiple sources, including the MCLK pin, the BCLK pin, the GPIO pin or the output of the internal PLL, where the input to the PLL again can be derived from the MCLK pin, the BCLK or GPIO pins. Although using the PLL ensures the availability of a suitable clock signal, PLL use is not recommended for the lowest power settings. The PLL is highly programmable and can accept available input clocks in the range of 512 kHz to 50 MHz.

10.2 Functional Block Diagram

Figure 19 shows the basic functional blocks of the device.

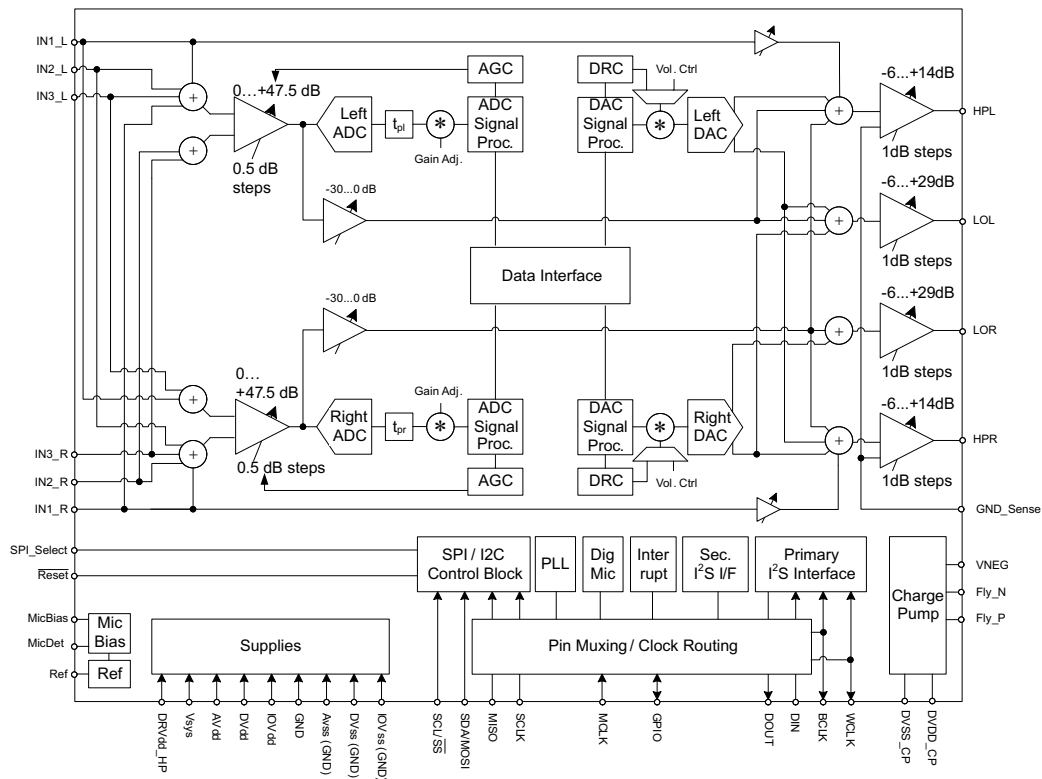

Figure 19. Block Diagram

10.3 Feature Description

10.3.1 Device Connections

10.3.1.1 Digital Pins

Only a small number of digital pins are dedicated to a single function; whenever possible, the digital pins have a default function, and also can be reprogrammed to cover alternative functions for various applications.

The fixed-function pins are Reset and the SPI_Select pin, which are HW control pins. Depending on the state of SPI_Select, the two control-bus pins SCL/SS and SDA/MOSI are configured for either I²C or SPI protocol.

Other digital IO pins can be configured for various functions via register control. An overview of available functionality is given in [Multifunction Pins](#).

Feature Description (continued)

10.3.1.1.1 Multifunction Pins

Table 1 shows the possible allocation of pins for specific functions. The PLL input, for example, can be programmed to be any of 4 pins (MCLK, BCLK, DIN, GPIO).

Table 1. Multifunction Pin Assignments

		1	2	3	4	5	6	7	8
	Pin Function	MCLK	BCLK	WCLK	DIN MFP1	DOUT MFP2	DMDIN/ MFP3/ SCLK	DMCLK/ MFP4/ MISO	GPIO MFP5
A	PLL Input	S ⁽¹⁾	S ⁽²⁾		E				S ⁽³⁾
B	Codec Clock Input	S ^{(1),D⁽⁴⁾}	S ⁽²⁾						S ⁽³⁾
C	I ² S BCLK input		S,D						
D	I ² S BCLK output		E ⁽⁵⁾						
E	I ² S WCLK input			E, D					
F	I ² S WCLK output			E					
G	I ² S ADC word clock input						E		E
H	I ² S ADC WCLK out							E	E
I	I ² S DIN				E, D				
J	I ² S DOUT					E, D			
K	General Purpose Output I					E			
K	General Purpose Output II							E	
K	General Purpose Output III								E
L	General Purpose Input I				E				
L	General Purpose Input II						E		
L	General Purpose Input III								E
M	INT1 output					E		E	E
N	INT2 output					E		E	E
Q	Secondary I ² S BCLK input						E		E
R	Secondary I ² S WCLK in						E		E
S	Secondary I ² S DIN						E		E
T	Secondary I ² S DOUT							E	
U	Secondary I ² S BCLK OUT					E		E	E
V	Secondary I ² S WCLK OUT					E		E	E
X	Aux Clock Output					E		E	E

(1) S⁽¹⁾: The MCLK pin can drive the PLL and Codec Clock inputs **simultaneously**.

(2) S⁽²⁾: The BCLK pin can drive the PLL and Codec Clock and audio interface bit clock inputs **simultaneously**.

(3) S⁽³⁾: The GPIO/MFP5 pin can drive the PLL and Codec Clock inputs simultaneously.

(4) D: Default Function

(5) E: The pin is **exclusively** used for this function, no other function can be implemented with the same pin. (If GPIO/MFP5 has been allocated for General Purpose Output, it cannot be used as the INT1 output at the same time.)

10.3.1.2 Analog Pins

Analog functions can also be configured to a large degree. For minimum power consumption, analog blocks are powered down by default. The blocks can be powered up with fine granularity according to the application needs.

10.3.2 Analog Audio I/O

The analog IO path of the TLV320AIC3256 features a large set of options for signal conditioning as well as signal routing:

- 6 analog inputs which can be mixed and-or multiplexed in single-ended and-or differential configuration
- 2 programmable gain amplifiers (PGA) with a range of 0 to +47.5dB
- 2 mixer amplifiers for analog bypass

- 2 low power analog bypass channels
- Mute function
- Channel-to-channel phase adjustment
- Fast charge of ac-coupling capacitors
- Anti thump

10.3.2.1 Analog Bypass

The TLV320AIC3256 offers two analog-bypass modes. In either of the modes, an analog input signal can be routed from an analog input pin to an amplifier driving an analog output pin. Neither the ADC nor the DAC resources are required for such operation.

In analog low-power bypass mode, line-level signals can be routed directly from the analog inputs IN1_L to the left headphone amplifier (HPL) and IN1_R to HPR.

10.3.2.2 ADC Bypass Using Mixer Amplifiers

In addition to the analog low-power bypass mode, another bypass mode uses the programmable gain amplifiers of the input stage in conjunction with a mixer amplifier. With this mode, microphone-level signals can be amplified and routed to the line or headphone outputs, fully bypassing the ADC and DAC.

To enable this mode, the mixer amplifiers are powered on via software command.

10.3.2.3 Headphone Output

The stereo headphone drivers on pins HPL and HPR can drive loads with impedances down to 16Ω in single-ended DC-coupled headphone configurations. An integral charge pump generates the negative supply required to operate the headphone drivers in dc-coupled mode, where the common mode of the output signal is made equal to the ground of the headphone load using a ground-sense circuit. Operation of headphone drivers in dc-coupled (ground centered mode) eliminates the need for large dc-blocking capacitors.

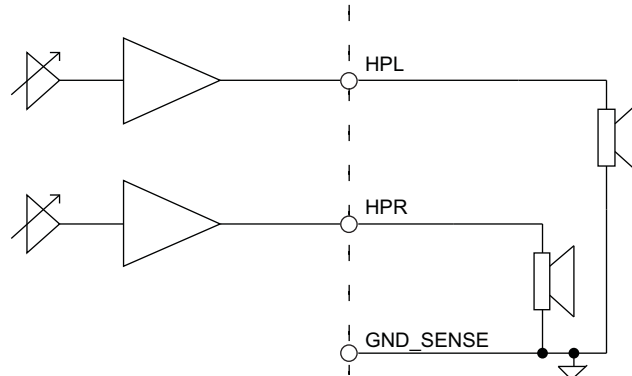

Figure 20. TLV320AIC3256 Ground-Centered Headphone Output

Alternatively the headphone amplifier can also be operated in a unipolar circuit configuration using DC blocking capacitors.

10.3.2.4 Line Outputs

The stereo line level drivers on LOL and LOR pins can drive a wide range of line level resistive impedances in the range of 600Ω to 10kΩ. The output common modes of line level drivers can be configured to equal either the analog input common-mode setting, or 1.65V. With output common-mode setting of 1.65V and DRVdd_HP supply at 3.3V the line-level drivers can drive up to 1Vrms output signal. The line-level drivers can drive out a mixed combination of DAC signal and attenuated ADC PGA signal. Signal mixing is register-programmable.

10.3.3 ADC

The TLV320AIC3256 includes a stereo audio ADC, which uses a delta-sigma modulator with a programmable oversampling ratio, followed by a digital decimation filter. The ADC supports sampling rates from 8kHz to 192kHz. In order to provide optimal system power management, the stereo recording path can be powered up one channel at a time, to support the case where only mono record capability is required.

The ADC path of the TLV320AIC3256 features a large set of options for signal conditioning as well as signal routing:

- Two ADCs
- Six analog inputs which can be mixed and-or multiplexed in single-ended and-or differential configuration
- Two programmable gain amplifiers (PGA) with a range of 0 to +47.5dB
- Two mixer amplifiers for analog bypass
- Two low power analog bypass channels
- Fine gain adjustment of digital channels with 0.1dB step size
- Digital volume control with a range of -12 to +20dB
- Mute function

In addition to the standard set of ADC features the TLV320AIC3256 also offers the following special functions:

- Channel-to-channel phase adjustment
- Fast charge of ac-coupling capacitors
- Anti thump
- Adaptive filter mode

10.3.3.1 ADC Processing

The TLV320AIC3256 ADC channel includes a built-in digital decimation filter to process the oversampled data from the to generate digital data at Nyquist sampling rate with high dynamic range. The decimation filter can be chosen from three different types, depending on the required frequency response, group delay and sampling rate.

10.3.3.1.1 ADC Processing Blocks

The TLV320AIC3256 offers a range of processing blocks which implement various signal processing capabilities along with decimation filtering. These processing blocks give users the choice of how much and what type of signal processing they may use and which decimation filter is applied.

The choice between these processing blocks is part of the PowerTune strategy to balance power conservation and signal-processing flexibility. Less signal-processing capability reduces the power consumed by the device. [Table 2](#) gives an overview of the available processing blocks and their properties. The Resource Class Column (RC) gives an approximate indication of power consumption.

The signal processing blocks available are:

- First-order IIR
- Scalable number of biquad filters
- Variable-tap FIR filter

The processing blocks are tuned for common cases and can achieve high anti-alias filtering or low group delay in combination with various signal processing effects such as audio effects and frequency shaping. The available first order IIR, BiQuad and FIR filters have fully user-programmable coefficients. The Resource Class Column (RC) gives an approximate indication of power consumption.

Table 2. ADC Processing Blocks

Processing Blocks	Channel	Decimation Filter	1st Order IIR Available	Number BiQuads	FIR	Required AOSR Value	Resource Class
PRB_R1 ⁽¹⁾	Stereo	A	Yes	0	No	128,64	6
PRB_R2	Stereo	A	Yes	5	No	128,64	8
PRB_R3	Stereo	A	Yes	0	25-Tap	128,64	8
PRB_R4	Right	A	Yes	0	No	128,64	3
PRB_R5	Right	A	Yes	5	No	128,64	4
PRB_R6	Right	A	Yes	0	25-Tap	128,64	4
PRB_R7	Stereo	B	Yes	0	No	64	3
PRB_R8	Stereo	B	Yes	3	No	64	4
PRB_R9	Stereo	B	Yes	0	20-Tap	64	4
PRB_R10	Right	B	Yes	0	No	64	2
PRB_R11	Right	B	Yes	3	No	64	2
PRB_R12	Right	B	Yes	0	20-Tap	64	2
PRB_R13	Stereo	C	Yes	0	No	32	3
PRB_R14	Stereo	C	Yes	5	No	32	4
PRB_R15	Stereo	C	Yes	0	25-Tap	32	4
PRB_R16	Right	C	Yes	0	No	32	2
PRB_R17	Right	C	Yes	5	No	32	2
PRB_R18	Right	C	Yes	0	25-Tap	32	2

(1) Default

For more detailed information see the TLV320AIC3256 Application Reference Guide, [SLAU306](#).

10.3.4 DAC

The TLV320AIC3256 includes a stereo audio DAC supporting data rates from 8kHz to 192kHz. Each channel of the stereo audio DAC consists of a signal-processing engine with fixed processing blocks, a programmable miniDSP, a digital interpolation filter, multi-bit digital delta-sigma modulator, and an analog reconstruction filter. The DAC is designed to provide enhanced performance at low sampling rates through increased oversampling and image filtering, thereby keeping quantization noise generated within the delta-sigma modulator and signal images strongly suppressed within the audio band to beyond 20kHz. To handle multiple input rates and optimize power dissipation and performance, the TLV320AIC3256 allows the system designer to program the oversampling rates over a wide range from 1 to 1024. The system designer can choose higher oversampling ratios for lower input data rates and lower oversampling ratios for higher input data rates.

The TLV320AIC3256 DAC channel includes a built-in digital interpolation filter to generate oversampled data for the sigma-delta modulator. The interpolation filter can be chosen from three different types depending on required frequency response, group delay and sampling rate.

The DAC path of the TLV320AIC3256 features many options for signal conditioning and signal routing:

- 2 headphone amplifiers
 - Ground-centered, bipolar operation or unipolar operation
 - Usable in single-ended or differential mode
 - Analog volume setting with a range of -6 to +14dB
- 2 line-out amplifiers
 - Usable in single-ended or differential mode
 - Analog volume setting with a range of -6 to +29dB
- Digital volume control with a range of -63.5 to +24dB
- Mute function
- Dynamic range compression (DRC)

In addition to the standard set of DAC features the TLV320AIC3256 also offers the following special features:

- Built in sine wave generation (beep generator)
- Digital auto mute
- Adaptive filter mode

10.3.4.1 DAC Processing Blocks — Overview

Table 3. Overview – DAC Predefined Processing Blocks

Processing Block No.	Interpolation Filter	Channel	1st Order IIR Available	Num. of Biquads	DRC	3D	Beep Generator
PRB_P1 ⁽¹⁾	A	Stereo	No	3	No	No	No
PRB_P2	A	Stereo	Yes	6	Yes	No	No
PRB_P3	A	Stereo	Yes	6	No	No	No
PRB_P4	A	Left	No	3	No	No	No
PRB_P5	A	Left	Yes	6	Yes	No	No
PRB_P6	A	Left	Yes	6	No	No	No
PRB_P7	B	Stereo	Yes	0	No	No	No
PRB_P8	B	Stereo	No	4	Yes	No	No
PRB_P9	B	Stereo	No	4	No	No	No
PRB_P10	B	Stereo	Yes	6	Yes	No	No
PRB_P11	B	Stereo	Yes	6	No	No	No
PRB_P12	B	Left	Yes	0	No	No	No
PRB_P13	B	Left	No	4	Yes	No	No
PRB_P14	B	Left	No	4	No	No	No
PRB_P15	B	Left	Yes	6	Yes	No	No
PRB_P16	B	Left	Yes	6	No	No	No
PRB_P17	C	Stereo	Yes	0	No	No	No
PRB_P18	C	Stereo	Yes	4	Yes	No	No
PRB_P19	C	Stereo	Yes	4	No	No	No
PRB_P20	C	Left	Yes	0	No	No	No
PRB_P21	C	Left	Yes	4	Yes	No	No
PRB_P22	C	Left	Yes	4	No	No	No
PRB_P23	A	Stereo	No	2	No	Yes	No
PRB_P24	A	Stereo	Yes	5	Yes	Yes	No
PRB_P25	A	Stereo	Yes	5	Yes	Yes	Yes

(1) Default

For more detailed information see the TLV320AIC3256 Application Reference Guide, [SLAU306](#).

10.3.5 PowerTune

The TLV320AIC3256 features PowerTune, a mechanism to balance power-versus-performance trade-offs at the time of device configuration. The device can be tuned to minimize power dissipation, to maximize performance, or to an operating point between the two extremes to best fit the application. The TLV320AIC3256 PowerTune modes are called PTM_R1 to PTM_R4 for the recording (ADC) path and PTM_P1 to PTM_P4 for the playback (DAC) path.

For more detailed information see the TLV320AIC3256 Application Reference Guide, [SLAU306](#).

10.3.6 Digital Audio IO Interface

Audio data flows between the host processor and the TLV320AIC3256 on the digital audio data serial interface, or audio bus. This very flexible bus includes left or right-justified data options, support for I²S or PCM protocols, programmable data length options, a TDM mode for multichannel operation, very flexible master-slave configurability for each bus clock line, and the ability to communicate with multiple devices within a system directly.

The audio bus of the TLV320AIC3256 can be configured for left or right-justified, I²S, DSP, or TDM modes of operation, where communication with standard PCM interfaces is supported within the TDM mode. These modes are all MSB-first, with data width programmable as 16, 20, 24, or 32 bits by configuring Page 0, Register 27, D(5:4). In addition, the word clock and bit clock can be independently configured in either Master or Slave mode, for flexible connectivity to a wide variety of processors. The word clock is used to define the beginning of a frame, and may be programmed as either a pulse or a square-wave signal. The frequency of this clock corresponds to the maximum of the selected ADC and DAC sampling frequencies.

The bit clock is used to clock in and clock out the digital audio data across the serial bus. When in Master mode, this signal can be programmed to generate variable clock pulses by controlling the bit-clock divider in Page 0, Register 30. The number of bit-clock pulses in a frame may need adjustment to accommodate various word lengths, and to support the case when multiple TLV320AIC3256s may share the same audio bus.

The TLV320AIC3256 also includes a feature to offset the position of start of data transfer with respect to the word-clock. Control the offset in terms of number of bit-clocks by programming Page 0, Register 28.

The TLV320AIC3256 also has the feature to invert the polarity of the bit-clock used to transfer the audio data as compared to the default clock polarity used. This feature can be used independently of the mode of audio interface chosen. Page 0, Register 29, D(3) configures bit clock polarity.

The TLV320AIC3256 further includes programmability (Page 0, Register 27, D(0)) to place the DOUT line into a hi-Z (3-state) condition during all bit clocks when valid data is not being sent. By combining this capability with the ability to program at what bit clock in a frame the audio data begins, time-division multiplexing (TDM) can be accomplished, enabling the use of multiple codecs on a single audio serial data bus. When the audio serial data bus is powered down while configured in master mode, the pins associated with the interface are put into a hi-Z output condition.

By default when the word-clocks and bit-clocks are generated by the TLV320AIC3256, these clocks are active only when the codec (ADC, DAC or both) are powered up within the device. This intermittent clock operation reduces power consumption. However, it also supports a feature when both the word clocks and bit-clocks can be active even when the codec in the device is powered down. This continuous clock feature is useful when using the TDM mode with multiple codecs on the same bus, or when word-clock or bit-clocks are used in the system as general-purpose clocks.

10.3.7 Clock Generation and PLL

The TLV320AIC3256 supports a wide range of options for generating clocks for the ADC and DAC sections as well as interface and other control blocks. The clocks for ADC and DAC require a source reference clock. This clock can be provided on variety of device pins such as MCLK, BCLK or GPI pins. The CODEC_CLKIN can then be routed through highly-flexible clock dividers to generate the various clocks required for ADC, DAC and the miniDSP sections. In the event that the desired audio or miniDSP clocks cannot be generated from the reference clocks on MCLK BCLK or GPIO, the TLV320AIC3256 also provides the option of using the on-chip PLL which supports a wide range of fractional multiplication values to generate the required clocks. Starting from CODEC_CLKIN the TLV320AIC3256 provides several programmable clock dividers to help achieve a variety of sampling rates for ADC, DAC and clocks for the miniDSP.

To minimize power consumption, the system ideally provides a master clock that is a suitable integer multiple of the desired sampling frequencies. In such cases, internal dividers can be programmed to set up the required internal clock signals at very low power consumption. For cases where such master clocks are not available, the built-in PLL can be used to generate a clock signal that serves as an internal master clock. In fact, this master clock can also be routed to an output pin and may be used elsewhere in the system. The clock system is flexible enough that it even allows the internal clocks to be derived directly from an external clock source, while the PLL is used to generate some other clock that is only used outside the TLV320AIC3256.

For more detailed information see the TLV320AIC3256 Application Reference Guide, [SLAU306](#).

10.3.8 Control Interfaces

The TLV320AIC3256 control interface supports SPI or I²C communication protocols, with the protocol selectable using the SPI_SELECT pin. For SPI, SPI_SELECT should be tied high; for I²C, SPI_SELECT should be tied low. Changing the state of SPI_SELECT during device operation is not recommended.

10.3.8.1 I²C Control

The TLV320AIC3256 supports the I²C control protocol, and will respond to the I²C address of 0011000. I²C is a two-wire, open-drain interface supporting multiple devices and masters on a single bus. Devices on the I²C bus only drive the bus lines LOW by connecting them to ground; they never drive the bus lines HIGH. Instead, the bus wires are pulled HIGH by pullup resistors, so the bus wires are HIGH when no device is driving them LOW. This circuit prevents two devices from conflicting; if two devices drive the bus simultaneously, there is no driver contention.

10.3.8.2 SPI Control

In the SPI control mode, the TLV320AIC3256 uses the pins $\overline{\text{SCL/SS}}$ as $\overline{\text{SS}}$, SCLK as SCLK, MISO as MISO, SDA/MOSI as MOSI; a standard SPI port with clock polarity setting of 0 (typical microprocessor SPI control bit CPOL = 0). The SPI port allows full-duplex, synchronous, serial communication between a host processor (the master) and peripheral devices (slaves). The SPI master (in this case, the host processor) generates the synchronizing clock (driven onto SCLK) and initiates transmissions. The SPI slave devices (such as the TLV320AIC3256) depend on a master to start and synchronize transmissions. A transmission begins when initiated by an SPI master. The byte from the SPI master begins shifting in on the slave MOSI pin under the control of the master serial clock (driven onto SCLK). As the byte shifts in on the MOSI pin, a byte shifts out on the MISO pin to the master shift register.

For more detailed information see the TLV320AIC3256 Application Reference Guide, [SLAU306](#).

10.4 Device Functional Modes

The following special functions are available to support advanced system requirements:

- Headset detection
- Interrupt generation
- Flexible pin multiplexing

For more detailed information see the TLV320AIC3256 Application Reference Guide, [SLAU306](#).

10.4.1 MiniDSP

The TLV320AIC3256 features two miniDSP cores. The first miniDSP core is tightly coupled to the ADC, the second miniDSP core is tightly coupled to the DAC. The fully programmable algorithms for the miniDSP must be loaded into the device after power up. The miniDSPs have direct access to the digital stereo audio stream on the ADC and on the DAC side, offering the possibility for advanced, very-low group delay DSP algorithms. Each miniDSP can run up to 1152 instructions on every audio sample at a 48kHz sample rate. The two cores can run fully synchronized and can exchange data.

10.4.2 Software

Software development for the TLV320AIC3256 is supported through TI's comprehensive PurePath Studio Development Environment; a powerful, easy-to-use tool designed specifically to simplify software development on the TLV320AIC3256 miniDSP audio platform. The Graphical Development Environment consists of a library of common audio functions that can be dragged-and-dropped into an audio signal flow and graphically connected together. The DSP code can then be assembled from the graphical signal flow with the click of a mouse.

Please visit the TLV320AIC3256 product folder on www.ti.com to learn more about PurePath Studio and the latest status on available, ready-to-use DSP algorithms.

10.5 Register Map

10.5.1 Register Map Summary

Table 4. Summary of Register Map

Decimal		Hex		DESCRIPTION
PAGE NO.	REG. NO.	PAGE NO.	REG. NO.	
0	0	0x00	0x00	Page Select Register
0	1	0x00	0x01	Software Reset Register
0	2	0x00	0x02	Reserved Register
0	3	0x00	0x03	Reserved Register
0	4	0x00	0x04	Clock Setting Register 1, Multiplexers
0	5	0x00	0x05	Clock Setting Register 2, PLL P&R Values
0	6	0x00	0x06	Clock Setting Register 3, PLL J Values
0	7	0x00	0x07	Clock Setting Register 4, PLL D Values (MSB)
0	8	0x00	0x08	Clock Setting Register 5, PLL D Values (LSB)
0	9-10	0x00	0x09-0x0A	Reserved Register
0	11	0x00	0x0B	Clock Setting Register 6, NDAC Values
0	12	0x00	0x0C	Clock Setting Register 7, MDAC Values
0	13	0x00	0x0D	DAC OSR Setting Register 1, MSB Value
0	14	0x00	0x0E	DAC OSR Setting Register 2, LSB Value
0	15	0x00	0x0F	miniDSP_D Instruction Control Register 1
0	16	0x00	0x10	miniDSP_D Instruction Control Register 2
0	17	0x00	0x11	miniDSP_D Interpolation Factor Setting Register
0	18	0x00	0x12	Clock Setting Register 8, NADC Values
0	19	0x00	0x13	Clock Setting Register 9, MADC Values
0	20	0x00	0x14	ADC Oversampling (AOSR) Register
0	21	0x00	0x15	miniDSP_A Instruction Control Register 1
0	22	0x00	0x16	miniDSP_A Instruction Control Register 2
0	23	0x00	0x17	miniDSP_A Decimation Factor Setting Register
0	24	0x00	0x18	Reserved Register
0	25	0x00	0x19	Clock Setting Register 10, Multiplexers
0	26	0x00	0x1A	Clock Setting Register 11, CLKOUT M divider value
0	27	0x00	0x1B	Audio Interface Setting Register 1
0	28	0x00	0x1C	Audio Interface Setting Register 2, Data offset setting
0	29	0x00	0x1D	Audio Interface Setting Register 3
0	30	0x00	0x1E	Clock Setting Register 12, BCLK N Divider
0	31	0x00	0x1F	Audio Interface Setting Register 4, Secondary Audio Interface
0	32	0x00	0x20	Audio Interface Setting Register 5
0	33	0x00	0x21	Audio Interface Setting Register 6
0	34	0x00	0x22	Digital Interface Misc. Setting Register
0	35	0x00	0x23	Reserved Register
0	36	0x00	0x24	ADC Flag Register
0	37	0x00	0x25	DAC Flag Register 1
0	38	0x00	0x26	DAC Flag Register 2
0	39-41	0x00	0x27-0x29	Reserved Register
0	42	0x00	0x2A	Sticky Flag Register 1
0	43	0x00	0x2B	Interrupt Flag Register 1
0	44	0x00	0x2C	Sticky Flag Register 2
0	45	0x00	0x2D	Sticky Flag Register 3

Register Map (continued)
Table 4. Summary of Register Map (continued)

Decimal		Hex		DESCRIPTION
PAGE NO.	REG. NO.	PAGE NO.	REG. NO.	
0	46	0x00	0x2E	Interrupt Flag Register 2
0	47	0x00	0x2F	Interrupt Flag Register 3
0	48	0x00	0x30	INT1 Interrupt Control Register
0	49	0x00	0x31	INT2 Interrupt Control Register
0	50-51	0x00	0x32-0x33	Reserved Register
0	52	0x00	0x34	GPIO/MFP5 Control Register
0	53	0x00	0x35	DOUT/MFP2 Function Control Register
0	54	0x00	0x36	DIN/MFP1 Function Control Register
0	55	0x00	0x37	MISO/MFP4 Function Control Register
0	56	0x00	0x38	SCLK/MFP3 Function Control Register
0	57-59	0x00	0x39-0x3B	Reserved Registers
0	60	0x00	0x3C	DAC Signal Processing Block Control Register
0	61	0x00	0x3D	ADC Signal Processing Block Control Register
0	62	0x00	0x3E	miniDSP_A and miniDSP_D Configuration Register
0	63	0x00	0x3F	DAC Channel Setup Register 1
0	64	0x00	0x40	DAC Channel Setup Register 2
0	65	0x00	0x41	Left DAC Channel Digital Volume Control Register
0	66	0x00	0x42	Right DAC Channel Digital Volume Control Register
0	67	0x00	0x43	Headset Detection Configuration Register
0	68	0x00	0x44	DRC Control Register 1
0	69	0x00	0x45	DRC Control Register 2
0	70	0x00	0x46	DRC Control Register 3
0	71	0x00	0x47	Beep Generator Register 1
0	72	0x00	0x48	Beep Generator Register 2
0	73	0x00	0x49	Beep Generator Register 3
0	74	0x00	0x4A	Beep Generator Register 4
0	75	0x00	0x4B	Beep Generator Register 5
0	76	0x00	0x4C	Beep Generator Register 6
0	77	0x00	0x4D	Beep Generator Register 7
0	78	0x00	0x4E	Beep Generator Register 8
0	79	0x00	0x4F	Beep Generator Register 9
0	80	0x00	0x50	Reserved Register
0	81	0x00	0x51	ADC Channel Setup Register
0	82	0x00	0x52	ADC Fine Gain Adjust Register
0	83	0x00	0x53	Left ADC Channel Volume Control Register
0	84	0x00	0x54	Right ADC Channel Volume Control Register
0	85	0x00	0x55	ADC Phase Adjust Register
0	86	0x00	0x56	Left Channel AGC Control Register 1
0	87	0x00	0x57	Left Channel AGC Control Register 2
0	88	0x00	0x58	Left Channel AGC Control Register 3
0	89	0x00	0x59	Left Channel AGC Control Register 4
0	90	0x00	0x5A	Left Channel AGC Control Register 5
0	91	0x00	0x5B	Left Channel AGC Control Register 6
0	92	0x00	0x5C	Left Channel AGC Control Register 7
0	93	0x00	0x5D	Left Channel AGC Control Register 8

Register Map (continued)
Table 4. Summary of Register Map (continued)

Decimal		Hex		DESCRIPTION
PAGE NO.	REG. NO.	PAGE NO.	REG. NO.	
0	94	0x00	0x5E	Right Channel AGC Control Register 1
0	95	0x00	0x5F	Right Channel AGC Control Register 2
0	96	0x00	0x60	Right Channel AGC Control Register 3
0	97	0x00	0x61	Right Channel AGC Control Register 4
0	98	0x00	0x62	Right Channel AGC Control Register 5
0	99	0x00	0x63	Right Channel AGC Control Register 6
0	100	0x00	0x64	Right Channel AGC Control Register 7
0	101	0x00	0x65	Right Channel AGC Control Register 8
0	102	0x00	0x66	DC Measurement Register 1
0	103	0x00	0x67	DC Measurement Register 2
0	104	0x00	0x68	Left Channel DC Measurement Output Register 1
0	105	0x00	0x69	Left Channel DC Measurement Output Register 2
0	106	0x00	0x6A	Left Channel DC Measurement Output Register 3
0	107	0x00	0x6B	Right Channel DC Measurement Output Register 1
0	108	0x00	0x6C	Right Channel DC Measurement Output Register 2
0	109	0x00	0x6D	Right Channel DC Measurement Output Register 3
0	110-127	0x00	0x6E-0x7F	Reserved Register
1	0	0x01	0x00	Page Select Register
1	1	0x01	0x01	Power Configuration Register 1
1	2	0x01	0x02	Power Configuration Register 2
1	3	0x01	0x03	Playback Configuration Register 1
1	4	0x01	0x04	Playback Configuration Register 2
1	5-8	0x01	0x05-0x08	Reserved Register
1	9	0x01	0x09	Output Driver Power Control Register
1	10	0x01	0x0A	Common Mode Control Register
1	11	0x01	0x0B	Over Current Protection Configuration Register
1	12	0x01	0x0C	HPL Routing Selection Register
1	13	0x01	0x0D	HPR Routing Selection Register
1	14	0x01	0x0E	LOL Routing Selection Register
1	15	0x01	0x0F	LOR Routing Selection Register
1	16	0x01	0x10	HPL Driver Gain Setting Register
1	17	0x01	0x11	HPR Driver Gain Setting Register
1	18	0x01	0x12	LOL Driver Gain Setting Register
1	19	0x01	0x13	LOR Driver Gain Setting Register
1	20	0x01	0x14	Headphone Driver Startup Control Register
1	21	0x01	0x15	Reserved Register
1	22	0x01	0x16	IN1L to HPL Volume Control Register
1	23	0x01	0x17	IN1R to HPR Volume Control Register
1	24	0x01	0x18	Mixer Amplifier Left Volume Control Register
1	25	0x01	0x19	Mixer Amplifier Right Volume Control Register
1	26-50	0x01	0x1A-0x32	Reserved Register
1	51	0x01	0x33	MICBIAS Configuration Register
1	52	0x01	0x34	Left MICPGA Positive Terminal Input Routing Configuration Register
1	53	0x01	0x35	Reserved Register
1	54	0x01	0x36	Left MICPGA Negative Terminal Input Routing Configuration Register

Register Map (continued)
Table 4. Summary of Register Map (continued)

Decimal		Hex		DESCRIPTION
PAGE NO.	REG. NO.	PAGE NO.	REG. NO.	
1	55	0x01	0x37	Right MICPGA Positive Terminal Input Routing Configuration Register
1	56	0x01	0x38	Reserved Register
1	57	0x01	0x39	Right MICPGA Negative Terminal Input Routing Configuration Register
1	58	0x01	0x3A	Floating Input Configuration Register
1	59	0x01	0x3B	Left MICPGA Volume Control Register
1	60	0x01	0x3C	Right MICPGA Volume Control Register
1	61	0x01	0x3D	ADC Power Tune Configuration Register
1	62	0x01	0x3E	ADC Analog Volume Control Flag Register
1	63	0x01	0x3F	DAC Analog Gain Control Flag Register
1	64-70	0x01	0x40-0x46	Reserved Register
1	71	0x01	0x47	Analog Input Quick Charging Configuration Register
1	72-122	0x01	0x48-0x7A	Reserved Register
1	123	0x01	0x7B	Reference Power-up Configuration Register
1	124	0x01	0x7C	Charge Pump Control Register
1	125	0x01	0x7D	Headphone Driver Configuration Register
1	126-127	0x01	0x7E-0x7F	Reserved Register
8	0	0x08	0x00	Page Select Register
8	1	0x08	0x01	ADC Adaptive Filter Configuration Register
8	2-7	0x08	0x02-0x07	Reserved
8	8-127	0x08	0x08-0x7F	ADC Coefficients Buffer-A C(0:29)
9-16	0	0x09-0x10	0x00	Page Select Register
9-16	1-7	0x09-0x10	0x01-0x07	Reserved
9-16	8-127	0x09-0x10	0x08-0x7F	ADC Coefficients Buffer-A C(30:255)
26-34	0	0x1A-0x22	0x00	Page Select Register
26-34	1-7	0x1A-0x22	0x01-0x07	Reserved.
26-34	8-127	0x1A-0x22	0x08-0x7F	ADC Coefficients Buffer-B C(0:255)
44	0	0x2C	0x00	Page Select Register
44	1	0x2C	0x01	DAC Adaptive Filter Configuration Register
44	2-7	0x2C	0x02-0x07	Reserved
44	8-127	0x2C	0x08-0x7F	DAC Coefficients Buffer-A C(0:29)
45-52	0	0x2D-0x34	0x00	Page Select Register
45-52	1-7	0x2D-0x34	0x01-0x07	Reserved.
45-52	8-127	0x2D-0x34	0x08-0x7F	DAC Coefficients Buffer-A C(30:255)
62-70	0	0x3E-0x46	0x00	Page Select Register
62-70	1-7	0x3E-0x46	0x01-0x07	Reserved.
62-70	8-127	0x3E-0x46	0x08-0x7F	DAC Coefficients Buffer-B C(0:255)
80-114	0	0x50-0x72	0x00	Page Select Register
80-114	1-7	0x50-0x72	0x01-0x07	Reserved.
80-114	8-127	0x50-0x72	0x08-0x7F	miniDSP_A Instructions
152-186	0	0x98-0xBA	0x00	Page Select Register
152-186	1-7	0x98-0xBA	0x01-0x07	Reserved.
152-186	8-127	0x98-0xBA	0x08-0x7F	miniDSP_D Instructions

11 Application and Implementation

NOTE

Information in the following applications sections is not part of the TI component specification, and TI does not warrant its accuracy or completeness. TI's customers are responsible for determining suitability of components for their purposes. Customers should validate and test their design implementation to confirm system functionality.

11.1 Application Information

The TLV320AIC3256 is a highly integrated stereo audio codec with integrated miniDSP and flexible digital audio interface options. It enables many different types of audio platforms having a need for stereo audio record and playback and needing to interface with other devices in the system over a digital audio interface.

11.2 Typical Application

Figure 21 shows a typical circuit configuration for a system using the TLV320AIC3256.

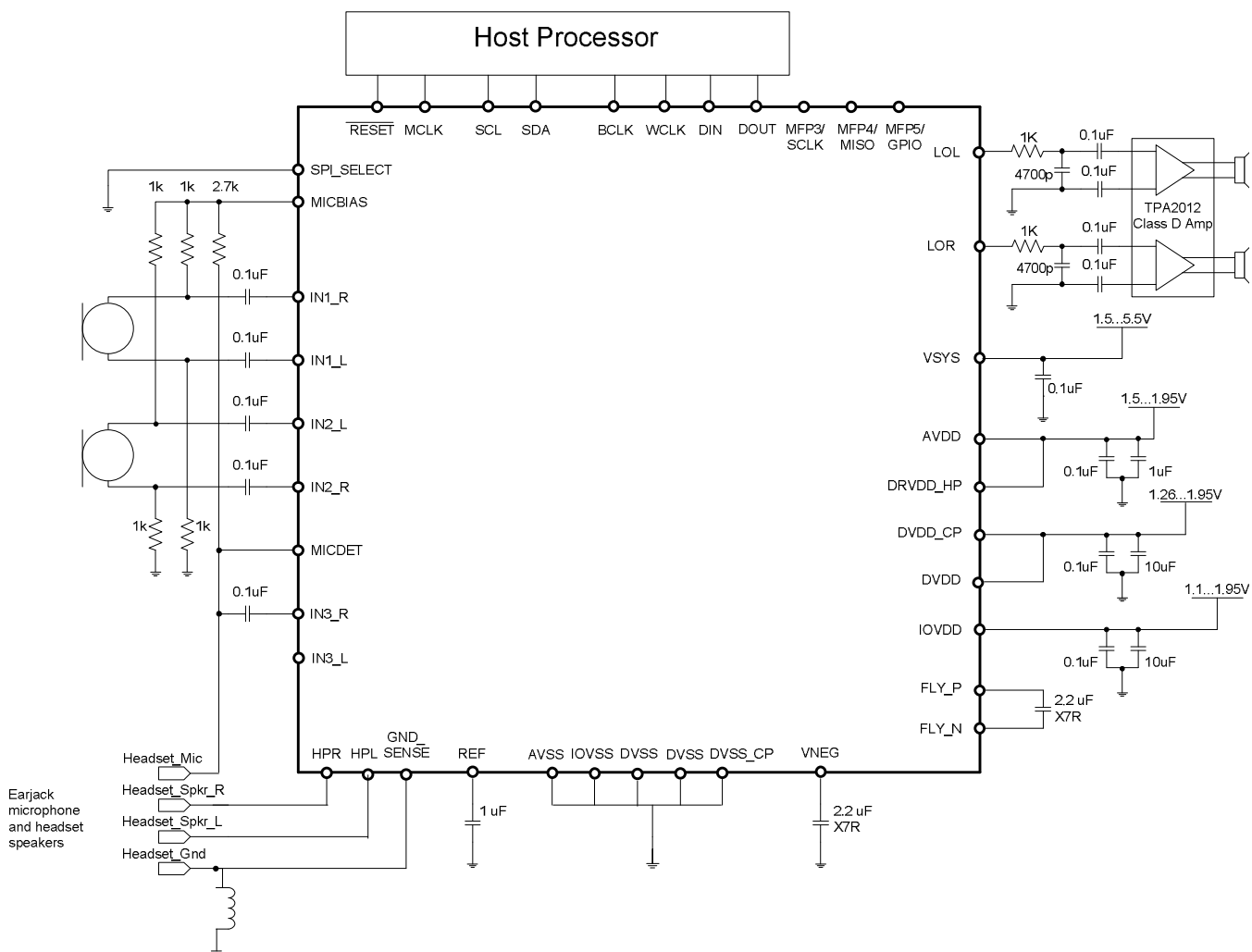

Figure 21. Typical Circuit Configuration

Typical Application (continued)

11.2.1 Design Requirements

11.2.1.1 Charge Pump Flying and Holding Capacitor

The TLV320AIC3256 features a built in charge-pump to generate a negative supply rail, VNEG from DVDD_CP. This negative voltage is used by the headphone amplifier to enable driving the output signal biased around ground potential. For proper operation of the charge pump and headphone amplifier, it is recommended that the flying capacitor connected between FLY_P and FLY_N terminals and the holding capacitor connected between VNEG and ground be of X7R type. It is recommended to use 2.2μF as capacitor values. Failure to use X7R type capacitor can result in degraded performance of charge pump and headphone amplifier.

11.2.1.2 Reference Filtering Capacitor

The TLV320AIC3256 has a built-in bandgap used to generate reference voltages and currents for the device. To achieve high SNR, the reference voltage on REF should be filtered using a 10-μF capacitor from REF terminal to ground.

11.2.1.3 MICBIAS

The TLV320AIC3256 has a built-in bias voltage output for biasing of microphones. No intentional capacitors should be connected directly to the MICBIAS output for filtering.

11.2.2 Detailed Design Procedures

11.2.2.1 Analog Input Connection

The analog inputs to TLV320AIC3256 should be ac-coupled to the device terminals to allow decoupling of signal source's common mode voltage with that of TLV320AIC3256's common mode voltage. The input coupling capacitor in combination with the selected input impedance of TLV320AIC3256 forms a high-pass filter.

$$F_c = 1/(2 \times \pi \times R_{eq} C_c) \quad (1)$$

$$C_c = 1/(2 \times \pi \times R_{eq} F_c) \quad (2)$$

For high fidelity audio recording application it is desirable to keep the cutoff frequency of the high pass filter as low as possible. For single-ended input mode, the equivalent input resistance R_{eq} can be calculated as

$$R_{eq} = R_{in} \times (1 + 2g)/(1+g) \quad (3)$$

where g is the analog PGA gain calculated in linear terms.

$$g = 10000 \times 2^{\text{floor}(G/6)}/R_{in} \quad (4)$$

where G is the analog PGA gain programmed in P1_R59-R60 (in dB) and R_{in} is the value of the resistor programmed in P1_R52-R57 and assumes $R_{in} = R_{cm}$ (as defined in P1_R52-R57).

For differential input mode, R_{eq} of the half circuit can be calculated as:

$$R_{eq} = R_{in} \quad (5)$$

where R_{in} is the value of the resistor programmed in P1_R52-R57, assuming symmetrical inputs.

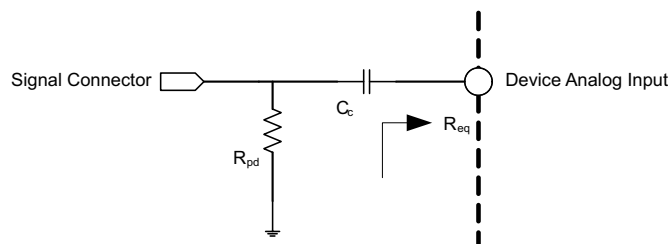

Figure 22. Analog Input Connection With Pull-down Resistor

Typical Application (continued)

When the analog signal is connected to the system through a connector such as audio jack, it is recommended to put a pull-down resistor on the signal as shown in Figure 22. The pulldown resistor helps keep the signal grounded and helps improve noise immunity when no source is connected to the connector. The pulldown resistor value should be chosen large enough to avoid loading of signal source.

Each analog input of the TLV320AIC3256 is capable of handling signal amplitude of 0.5 Vrms. If the input signal source can drive signals higher than the maximum value, an external resistor divider network as shown in Figure 23 should be used to attenuate the signal to less than 0.5Vrms before connecting the signal to the device. The resistor values of the network should be chosen to provide desired attenuation as well as Equation 6.

$$R_1 \parallel R_2 \ll R_{eq} \quad (6)$$

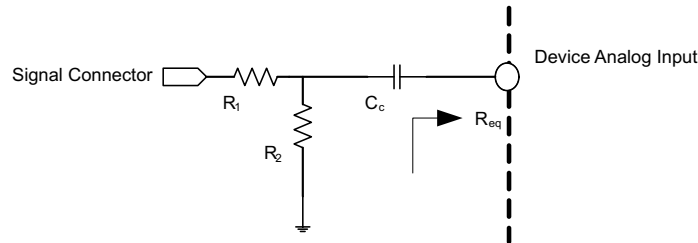

Figure 23. Analog Input Connection With Resistor Divider Network

Whenever any of the analog input terminals IN1_L, IN2_L, IN3_L, IN1_R, IN2_R or IN3_R are not used in an application, it is recommended to short the unused input terminals together (if convenient) and connect them to ground using a small capacitor (example 0.1 μ F).

11.2.2.2 Analog Output Connection

The line and headphone outputs of the TLV320AIC3256 drive a signal biased around the device common mode voltage. To avoid loading the common mode with the load, it is recommended to connect the single-ended load through an ac-coupling capacitor. The ac-coupling capacitor in combination with the load impedance forms a high pass filter.

$$F_c = 1/(2 \times \pi \times R_L C_c) \quad (7)$$

$$C_c = 1/(2 \times \pi \times R_L F_c) \quad (8)$$

For high fidelity playback, the cutoff frequency of the resultant high-pass filter should be kept low. For example with R_L of 10 k Ω , using 1- μ F coupling capacitor results in a cut-off frequency of 8 Hz.

For differential lineout configurations, the load should be directly connected between the differential outputs, with no coupling capacitor.

The TLV320AIC3256 supports headphone in single-ended configuration and drives the signal biased around ground. The headphone load can be directly connected between device terminals and ground.

Whenever any of the analog output terminals LOL, LOR, HPL or HPR are not used in an application, they should be left open or not connected.

Typical Application (continued)

11.2.3 Application Curves

Figure 24 shows the excellent low-distortion performance of the TLV320AIC3256 in a system over the 20-Hz to 20-kHz audio spectrum.

Figure 25 shows the distortion performance of the TLV320AIC3256 in a system over the input amplitude range.

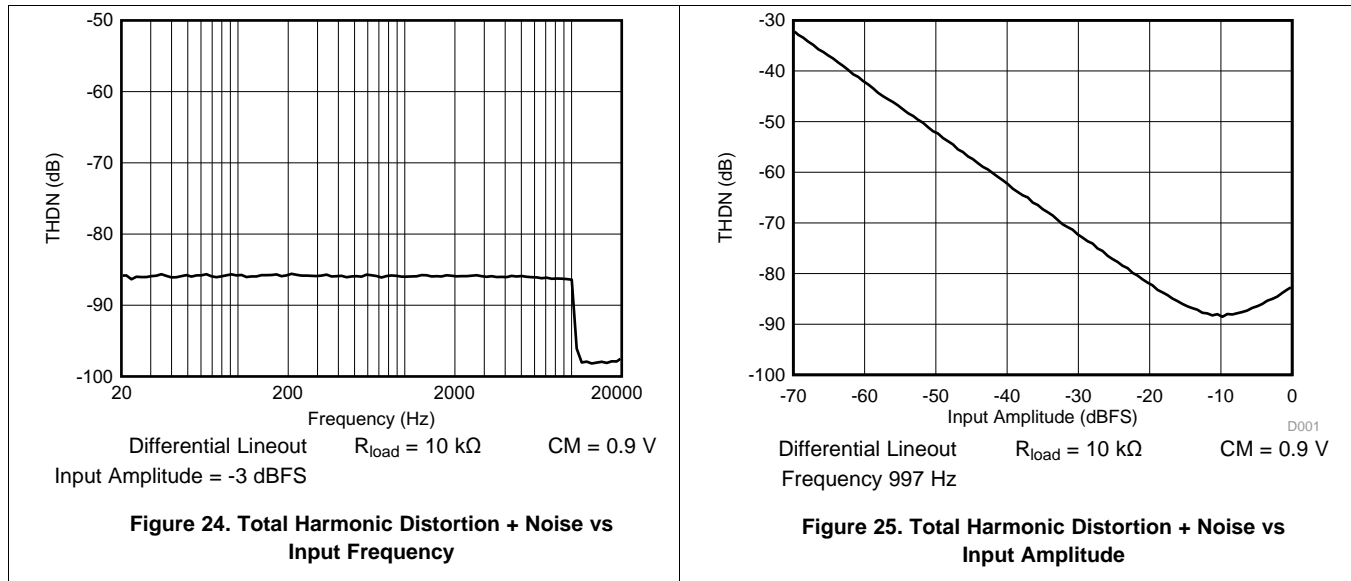

12 Power Supply Recommendations

Device power consumption largely depends on PowerTune configuration.

The device has an integrated charge pump. In ground-centered headphone configuration, all supplies can be conveniently supplied from a single 1.5V to 1.95V rail. The device has separate power domains for digital IO, digital core, analog core, charge-pump input and headphone drive, all of which can be connected together and be supplied from one source. For improved power efficiency, the digital core voltage can range from 1.26V to 1.95V. The IO voltage can be supplied in the range of 1.1V to 3.6V.

The device power supply V_{sys} can be supplied in the range of 1.5V to 5.5V. V_{sys} must always be greater than or equal to AV_{dd} and DV_{dd} voltages.

The AV_{DD} , DRV_{DD_HP} and DV_{DD_CP} power inputs are used to power the analog circuits including analog to digital converters, digital to analog converters, programmable gain amplifiers, headphone amplifiers, charge pump etc. The analog blocks in TLV320AIC3256 have high power supply rejection ratio, however it is recommended that these supplies be powered by well regulated power supplies like low dropout regulators (LDO) for optimal performance. When these power terminals are driven from a common power source, the current drawn from the source will depend upon blocks enabled inside the device. However as an example when all the internal blocks powered are enabled the source should be able to deliver 150mA of current.

The DV_{DD} powers the digital core of TLV320AIC3256, including the miniDSP, the audio serial interface, control interfaces (SPI or I2C), clock generation and PLL. The DV_{DD} power can be driven by high efficiency switching regulators or low drop out regulators. When the miniDSP_A and miniDSP_D are enabled in programmable mode and operated at peak frequencies, the supply source should be able to deliver approx 100mA of current. When the PRB modes are used instead of programmable miniDSP mode, then the peak current load on DV_{DD} supply source could be approximately 20 mA.

The IOV_{DD} powers the digital input and digital output buffers of TLV320AIC3256. The current consumption of this power depends on configuration of digital terminals as inputs or outputs. When the digital terminals are configured as outputs, the current consumption would depend on switching frequency of the signal and the load on the output terminal, which depends on board design and input capacitance of other devices connected to the signal.

Refer to [Figure 21](#) for recommendations on decoupling capacitors.

For more detailed information see the TLV320AIC3256 Application Reference Guide, [SLAU306](#).

13 Layout

13.1 Layout Guidelines

Each system design and PCB layout is unique. The layout should be carefully reviewed in the context of a specific PCB design. However, the following guidelines can optimize TLV320AIC3256 performance:

- Connect the thermal pad to ground.
- The decoupling capacitors for the power supplies should be placed close to the device terminals. [Figure 21](#) shows the recommended decoupling capacitors for the TLV320AIC3256.
- Place the flying capacitor between FLY_P and FLY_N near the device terminals, with no VIAS in the trace between the device terminals and the capacitor. Similarly, keep the decoupling capacitor on VNEG near the device terminal with minimal VIAS in the trace between the device terminals, capacitor and PCB ground.
- The TLV320AIC3256 internal voltage references must be filtered using external capacitors. Place the filter capacitors on REF near the device terminals for optimal performance.
- The TLV320AIC3256 reduces crosstalk by a separate ground sense signal for the headphone jack. To optimize crosstalk performance, use a separate trace from the HPVSS_SENSE terminal to the headphone jack ground terminal, with no other ground connections along the length.
- For analog differential audio signals, the signals should be routed differentially on the PCB for better noise immunity. Avoid crossing of digital and analog signals to avoid undesirable crosstalk.

13.2 Layout Example

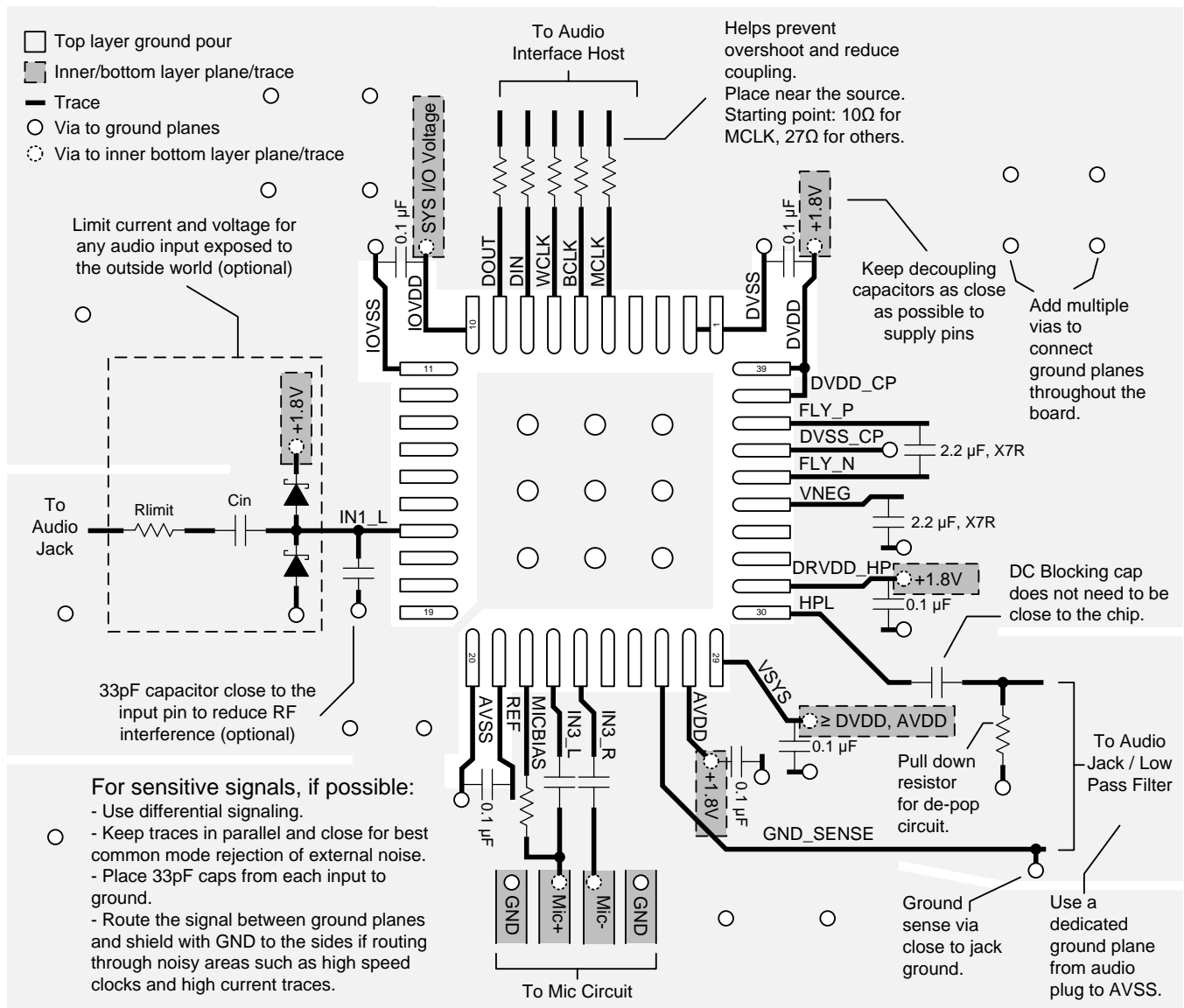

Figure 26. TLV320AIC3256 Layout

Example layout views can be found in the EVM User Guide:

- <http://www.ti.com/tool/TLV320AIC3256EVM-U>

14 Device and Documentation Support

14.1 Documentation Support

14.1.1 Related Documentation

TLV320AIC3256 Application Reference, [SLAU306](#)

14.2 Trademarks

PowerTune is a trademark of Texas Instruments.
All other trademarks are the property of their respective owners.

14.3 Electrostatic Discharge Caution



These devices have limited built-in ESD protection. The leads should be shorted together or the device placed in conductive foam during storage or handling to prevent electrostatic damage to the MOS gates.

14.4 Glossary

[SLYZ022](#) — *TI Glossary*.

This glossary lists and explains terms, acronyms, and definitions.

15 Mechanical, Packaging, and Orderable Information

The following pages include mechanical, packaging, and orderable information. This information is the most current data available for the designated devices. This data is subject to change without notice and revision of this document. For browser-based versions of this data sheet, refer to the left-hand navigation.

PACKAGING INFORMATION

Orderable Device	Status (1)	Package Type	Package Drawing	Pins	Package Qty	Eco Plan (2)	Lead/Ball Finish (6)	MSL Peak Temp (3)	Op Temp (°C)	Device Marking (4/5)	Samples
TLV320AIC3256IRSBR	ACTIVE	WQFN	RSB	40	3000	Green (RoHS & no Sb/Br)	CU NIPDAU	Level-2-260C-1 YEAR	-40 to 85	AIC 3256I	Samples
TLV320AIC3256IRSBT	ACTIVE	WQFN	RSB	40	250	Green (RoHS & no Sb/Br)	CU NIPDAU	Level-2-260C-1 YEAR	-40 to 85	AIC 3256I	Samples
TLV320AIC3256IYZFR	ACTIVE	DSBGA	YZF	42	2500	Green (RoHS & no Sb/Br)	SNAGCU	Level-1-260C-UNLIM	-40 to 85	AIC3256I	Samples
TLV320AIC3256IYZFT	ACTIVE	DSBGA	YZF	42	250	Green (RoHS & no Sb/Br)	SNAGCU	Level-1-260C-UNLIM	-40 to 85	AIC3256I	Samples

(1) The marketing status values are defined as follows:

ACTIVE: Product device recommended for new designs.

LIFEBUY: TI has announced that the device will be discontinued, and a lifetime-buy period is in effect.

NRND: Not recommended for new designs. Device is in production to support existing customers, but TI does not recommend using this part in a new design.

PREVIEW: Device has been announced but is not in production. Samples may or may not be available.

OBSELETE: TI has discontinued the production of the device.

(2) Eco Plan - The planned eco-friendly classification: Pb-Free (RoHS), Pb-Free (RoHS Exempt), or Green (RoHS & no Sb/Br) - please check <http://www.ti.com/productcontent> for the latest availability information and additional product content details.

TBD: The Pb-Free/Green conversion plan has not been defined.

Pb-Free (RoHS): TI's terms "Lead-Free" or "Pb-Free" mean semiconductor products that are compatible with the current RoHS requirements for all 6 substances, including the requirement that lead not exceed 0.1% by weight in homogeneous materials. Where designed to be soldered at high temperatures, TI Pb-Free products are suitable for use in specified lead-free processes.

Pb-Free (RoHS Exempt): This component has a RoHS exemption for either 1) lead-based flip-chip solder bumps used between the die and package, or 2) lead-based die adhesive used between the die and leadframe. The component is otherwise considered Pb-Free (RoHS compatible) as defined above.

Green (RoHS & no Sb/Br): TI defines "Green" to mean Pb-Free (RoHS compatible), and free of Bromine (Br) and Antimony (Sb) based flame retardants (Br or Sb do not exceed 0.1% by weight in homogeneous material)

(3) MSL, Peak Temp. - The Moisture Sensitivity Level rating according to the JEDEC industry standard classifications, and peak solder temperature.

(4) There may be additional marking, which relates to the logo, the lot trace code information, or the environmental category on the device.

(5) Multiple Device Markings will be inside parentheses. Only one Device Marking contained in parentheses and separated by a "~" will appear on a device. If a line is indented then it is a continuation of the previous line and the two combined represent the entire Device Marking for that device.

(6) Lead/Ball Finish - Orderable Devices may have multiple material finish options. Finish options are separated by a vertical ruled line. Lead/Ball Finish values may wrap to two lines if the finish value exceeds the maximum column width.

Important Information and Disclaimer: The information provided on this page represents TI's knowledge and belief as of the date that it is provided. TI bases its knowledge and belief on information provided by third parties, and makes no representation or warranty as to the accuracy of such information. Efforts are underway to better integrate information from third parties. TI has taken and continues to take reasonable steps to provide representative and accurate information but may not have conducted destructive testing or chemical analysis on incoming materials and chemicals. TI and TI suppliers consider certain information to be proprietary, and thus CAS numbers and other limited information may not be available for release.

In no event shall TI's liability arising out of such information exceed the total purchase price of the TI part(s) at issue in this document sold by TI to Customer on an annual basis.

TAPE AND REEL INFORMATION

QUADRANT ASSIGNMENTS FOR PIN 1 ORIENTATION IN TAPE

*All dimensions are nominal

Device	Package Type	Package Drawing	Pins	SPQ	Reel Diameter (mm)	Reel Width W1 (mm)	A0 (mm)	B0 (mm)	K0 (mm)	P1 (mm)	W (mm)	Pin1 Quadrant
TLV320AIC3256IRSBR	WQFN	RSB	40	3000	330.0	12.4	5.3	5.3	1.5	8.0	12.0	Q2
TLV320AIC3256IRSBT	WQFN	RSB	40	250	180.0	12.4	5.3	5.3	1.5	8.0	12.0	Q2
TLV320AIC3256IYZFR	DSBGA	YZF	42	2500	330.0	12.4	3.5	3.7	0.81	8.0	12.0	Q1
TLV320AIC3256IYZFT	DSBGA	YZF	42	250	330.0	12.4	3.5	3.7	0.81	8.0	12.0	Q1

TAPE AND REEL BOX DIMENSIONS

*All dimensions are nominal

Device	Package Type	Package Drawing	Pins	SPQ	Length (mm)	Width (mm)	Height (mm)
TLV320AIC3256IRSBR	WQFN	RSB	40	3000	367.0	367.0	35.0
TLV320AIC3256IRSBT	WQFN	RSB	40	250	210.0	185.0	35.0
TLV320AIC3256IYZFR	DSBGA	YZF	42	2500	367.0	367.0	35.0
TLV320AIC3256IYZFT	DSBGA	YZF	42	250	367.0	367.0	35.0

GENERIC PACKAGE VIEW

RSB 40

WQFN - 0.8 mm max height

5 x 5 mm, 0.4 mm pitch

PLASTIC QUAD FLATPACK - NO LEAD

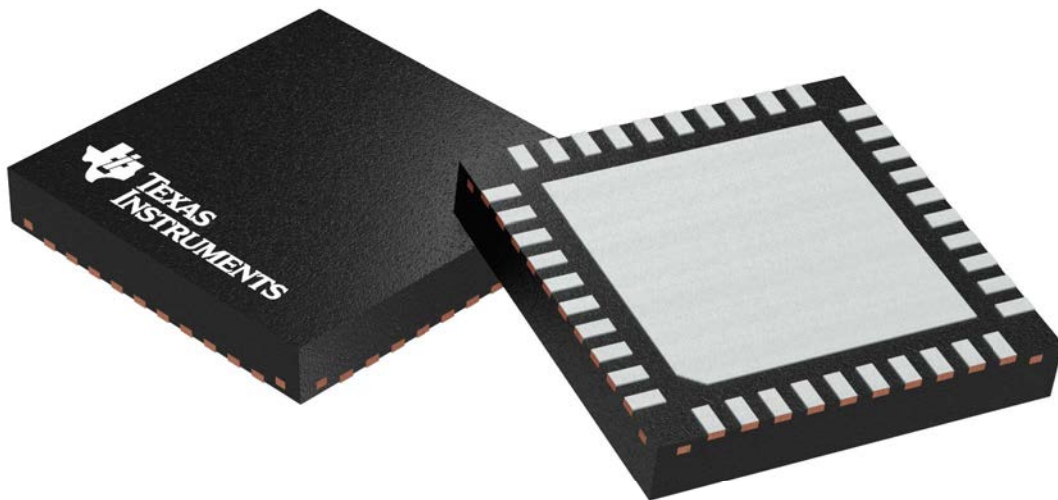

Images above are just a representation of the package family, actual package may vary.
Refer to the product data sheet for package details.

4207182/D

RSB0040B

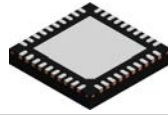

PACKAGE OUTLINE

WQFN - 0.8 mm max height

PLASTIC QUAD FLATPACK - NO LEAD

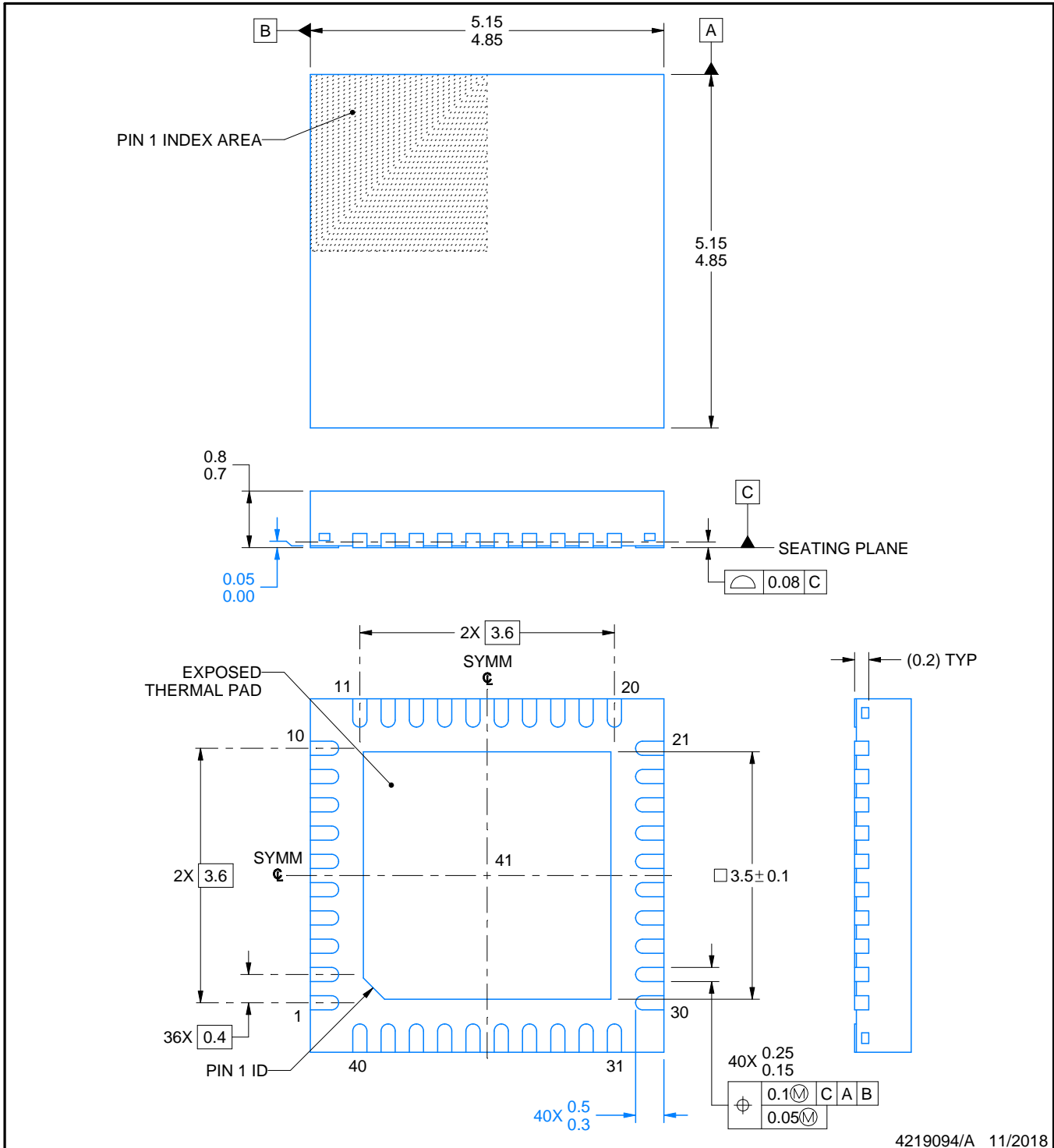

NOTES:

1. All linear dimensions are in millimeters. Any dimensions in parenthesis are for reference only. Dimensioning and tolerancing per ASME Y14.5M.
2. This drawing is subject to change without notice.
3. The package thermal pad must be soldered to the printed circuit board for thermal and mechanical performance.

EXAMPLE BOARD LAYOUT

RSB0040B

WQFN - 0.8 mm max height

PLASTIC QUAD FLATPACK - NO LEAD

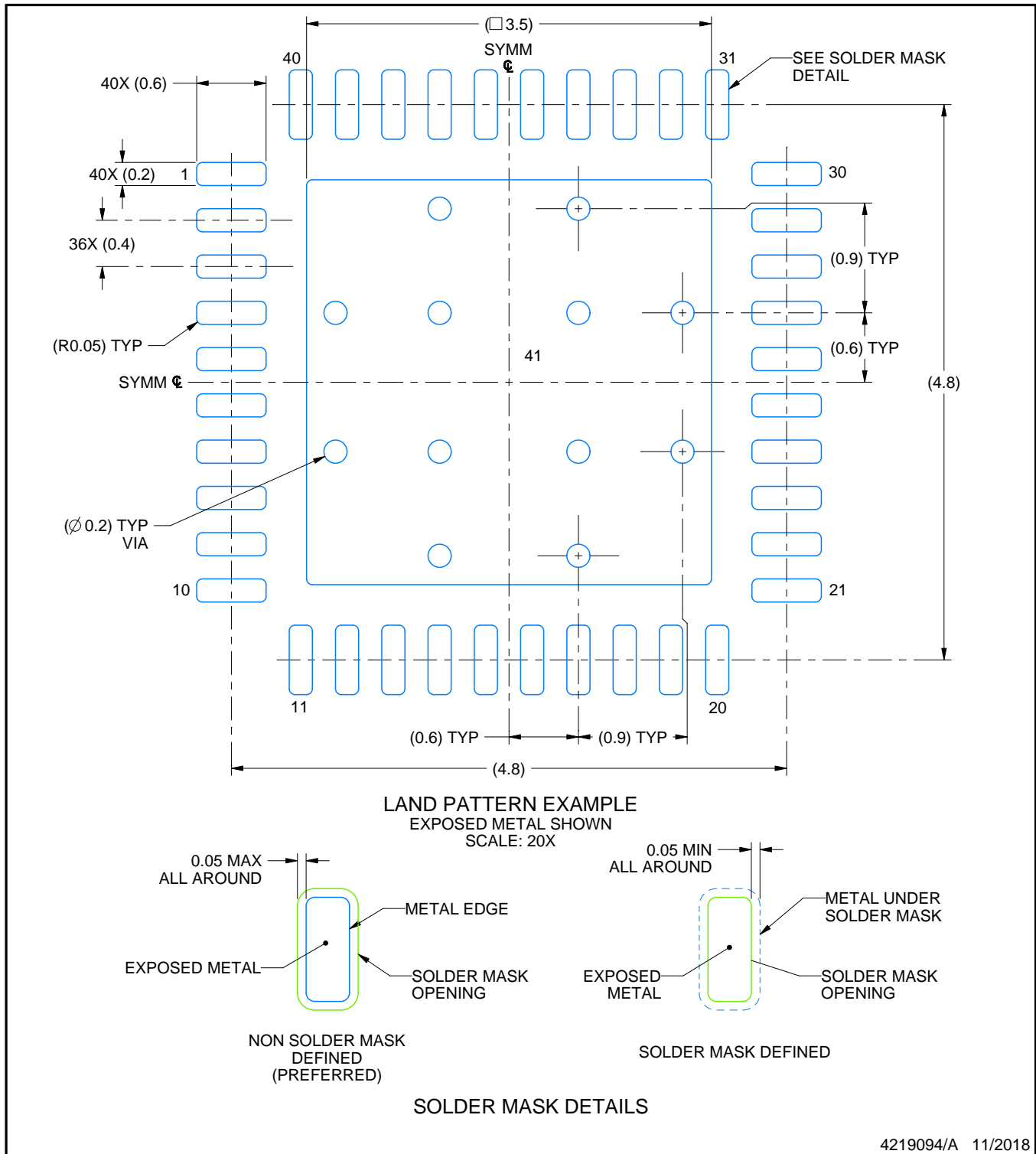

4219094/A 11/2018

NOTES: (continued)

4. This package is designed to be soldered to a thermal pad on the board. For more information, see Texas Instruments literature number SLUA271 (www.ti.com/lit/sluea271).
5. Vias are optional depending on application, refer to device data sheet. If any vias are implemented, refer to their locations shown on this view. It is recommended that vias under paste be filled, plugged or tented.

EXAMPLE STENCIL DESIGN

RSB0040B

WQFN - 0.8 mm max height

PLASTIC QUAD FLATPACK - NO LEAD

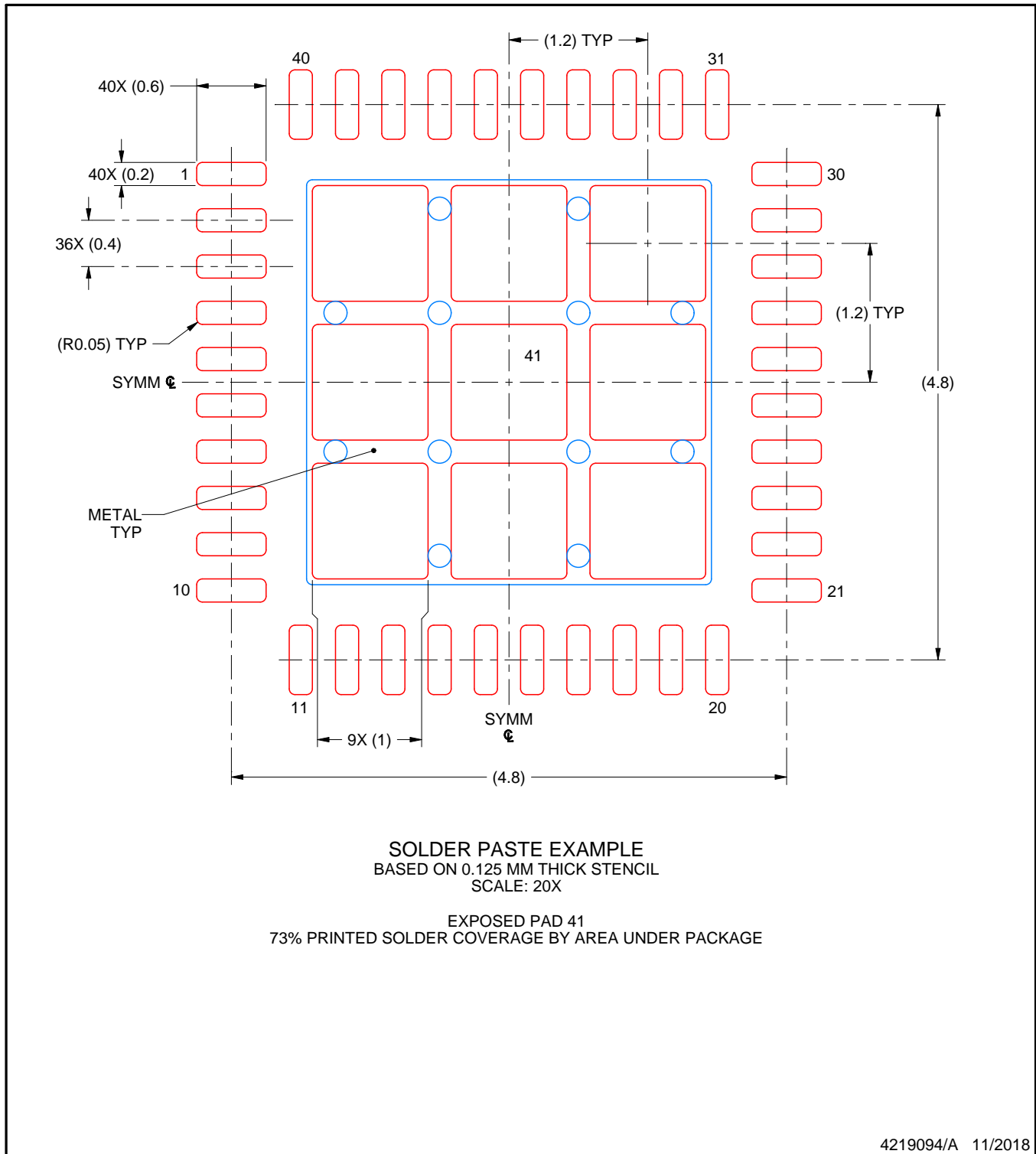

NOTES: (continued)

6. Laser cutting apertures with trapezoidal walls and rounded corners may offer better paste release. IPC-7525 may have alternate design recommendations.

RSB (S-PWQFN-N40)

PLASTIC QUAD FLATPACK NO-LEAD

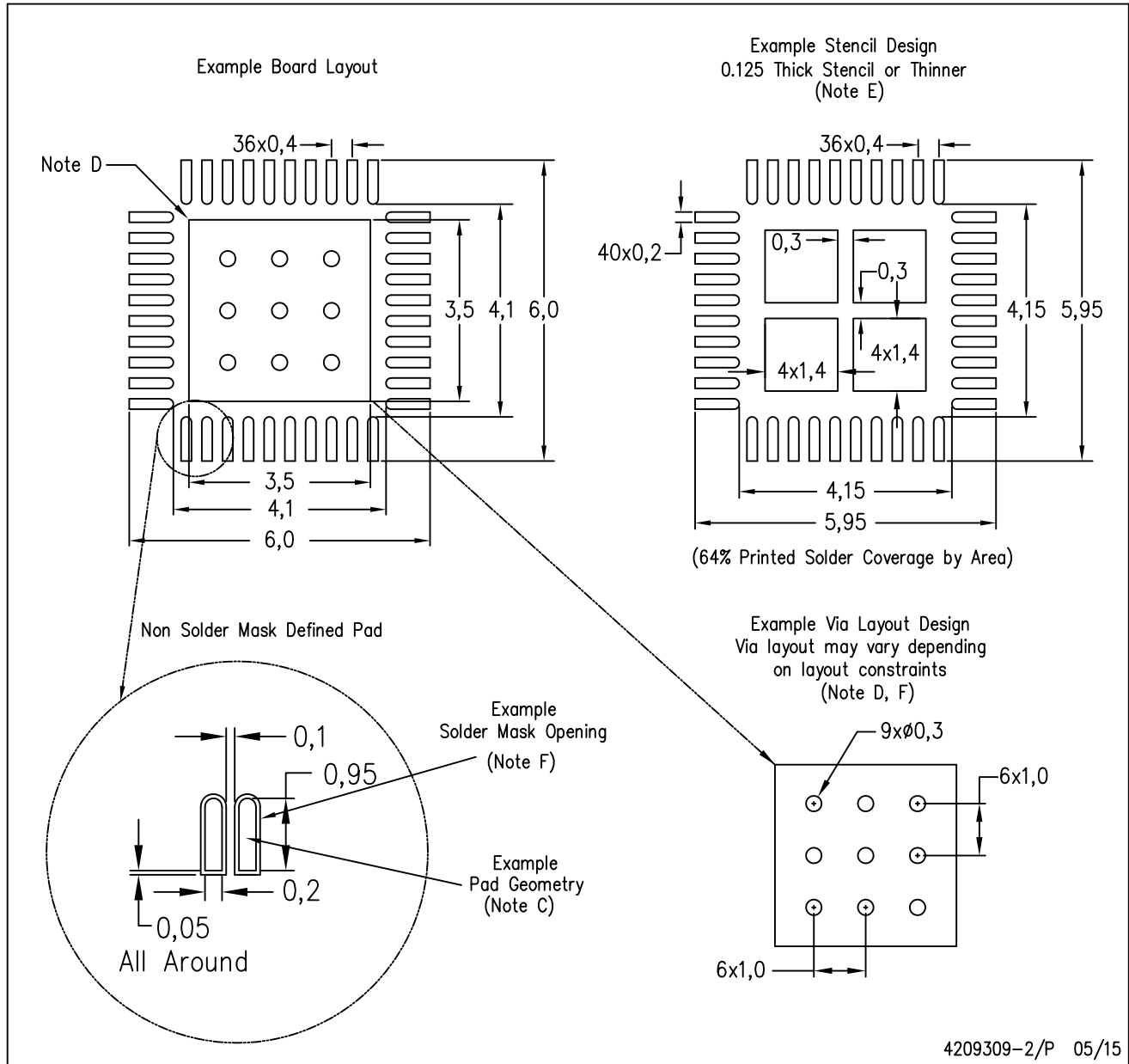

- NOTES:
- All linear dimensions are in millimeters.
 - This drawing is subject to change without notice.
 - Publication IPC-7351 is recommended for alternate designs.
 - This package is designed to be soldered to a thermal pad on the board. Refer to Application Note, Quad Flat-Pack Packages, Texas Instruments Literature No. SLUA271, and also the Product Data Sheets for specific thermal information, via requirements, and recommended board layout. These documents are available at www.ti.com <<http://www.ti.com>>.
 - Laser cutting apertures with trapezoidal walls and also rounding corners will offer better paste release. Customers should contact their board assembly site for stencil design recommendations. Refer to IPC 7525 for stencil design considerations.
 - Customers should contact their board fabrication site for recommended solder mask tolerances and via tenting recommendations for vias placed in the thermal pad.

YZF (R-XBGA-N42)

DIE-SIZE BALL GRID ARRAY

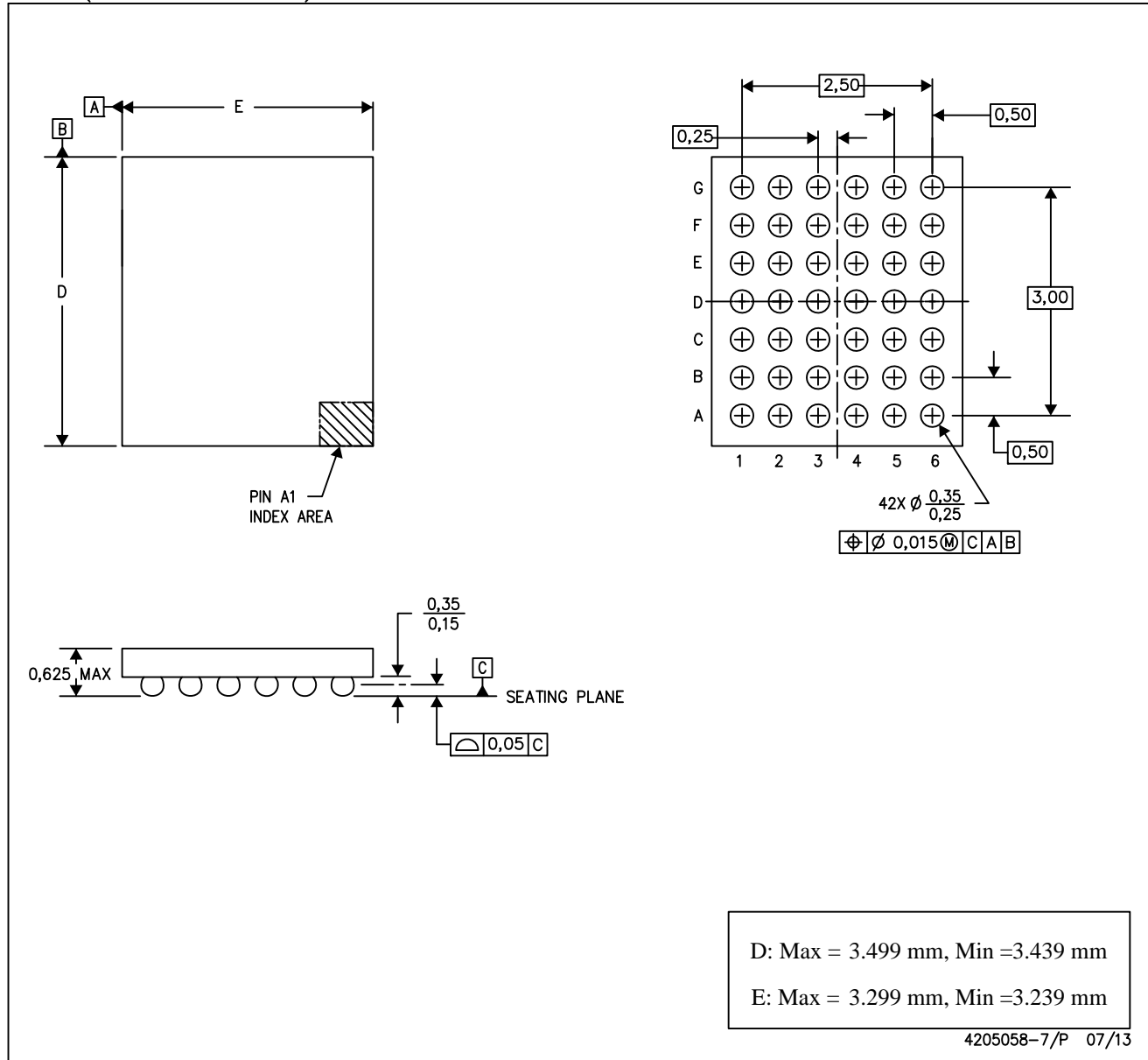

- NOTES: A. All linear dimensions are in millimeters. Dimensioning and tolerancing per ASME Y14.5M-1994.
 B. This drawing is subject to change without notice.
 C. NanoFree™ package configuration.

NanoFree is a trademark of Texas Instruments.

IMPORTANT NOTICE AND DISCLAIMER

TI PROVIDES TECHNICAL AND RELIABILITY DATA (INCLUDING DATASHEETS), DESIGN RESOURCES (INCLUDING REFERENCE DESIGNS), APPLICATION OR OTHER DESIGN ADVICE, WEB TOOLS, SAFETY INFORMATION, AND OTHER RESOURCES "AS IS" AND WITH ALL FAULTS, AND DISCLAIMS ALL WARRANTIES, EXPRESS AND IMPLIED, INCLUDING WITHOUT LIMITATION ANY IMPLIED WARRANTIES OF MERCHANTABILITY, FITNESS FOR A PARTICULAR PURPOSE OR NON-INFRINGEMENT OF THIRD PARTY INTELLECTUAL PROPERTY RIGHTS.

These resources are intended for skilled developers designing with TI products. You are solely responsible for (1) selecting the appropriate TI products for your application, (2) designing, validating and testing your application, and (3) ensuring your application meets applicable standards, and any other safety, security, or other requirements. These resources are subject to change without notice. TI grants you permission to use these resources only for development of an application that uses the TI products described in the resource. Other reproduction and display of these resources is prohibited. No license is granted to any other TI intellectual property right or to any third party intellectual property right. TI disclaims responsibility for, and you will fully indemnify TI and its representatives against, any claims, damages, costs, losses, and liabilities arising out of your use of these resources.

TI's products are provided subject to TI's Terms of Sale (www.ti.com/legal/termsofsale.html) or other applicable terms available either on ti.com or provided in conjunction with such TI products. TI's provision of these resources does not expand or otherwise alter TI's applicable warranties or warranty disclaimers for TI products.

Mailing Address: Texas Instruments, Post Office Box 655303, Dallas, Texas 75265
Copyright © 2019, Texas Instruments Incorporated

Looking for pricing, stock, or lifecycle information?

Click below to explore more details on WIN SOURCE:

 [View TLV320AIC3256IRSBT on WIN SOURCE](#)

 [Texas Instruments](#) Information

Optimize Your Supply Chain with WIN SOURCE Solutions

-  Global Sourcing Solution
-  Obsolete Management
-  Cost Control Management
-  Shortage Management
-  Alternative Solution
-  Excess Inventory Management