



**THE DATASHEET OF
ISO7640FMDW**



ISO764xFM Low-Power Quad-Channel Digital Isolators

1 Features

- Signaling Rate: 150 Mbps
- Low Power Consumption, Typical I_{CC} per Channel (3.3-V Supplies):
 - ISO7640FM: 2 mA at 25 Mbps
 - ISO7641FM: 2.4 mA at 25 Mbps
- Low Propagation Delay: 7-ns Typical
- Output Defaults to Low-State in Fail-Safe Mode
- Wide Temperature Range: -40°C to 125°C
- 50-KV/ μs Transient Immunity, Typical
- Long Life With SiO_2 Isolation Barrier
- Operates From 2.7-V, 3.3-V, and 5-V Supply and Logic Levels
- Wide Body SOIC-16 Package
- Safety and Regulatory Approvals
 - 6000 V_{PK} / 4243 V_{RMS} for 1 Minute per UL 1577
 - VDE 6000 V_{PK} Transient Overvoltage, 1414 V_{PK} Working Voltage per DIN V VDE V 0884-10 (VDE V 0884-10):2006-12
 - CSA Component Acceptance Notice 5A, IEC 60950-1, IEC 61010-1, and IEC 60601-1 End Equipment Standards
 - TUV 5 KV_{RMS} Reinforced Insulation per EN/UL/CSA 60950-1 and EN/UL/CSA 61010-1
 - CQC Reinforced Insulation per GB4943.1-2011

2 Applications

- Optocoupler Replacement in:
 - Industrial Fieldbus
 - Profibus
 - Modbus
 - DeviceNet™ Data Buses
 - Servo Control Interface
 - Motor Control
 - Power Supplies
 - Battery Packs

3 Description

ISO7640FM and ISO7641FM provide galvanic isolation up to 6 KV_{PK} for 1 minute per UL and VDE. These devices are also certified up to 5- KV_{RMS} Reinforced isolation at a working voltage of 400 V_{RMS} per end equipment standards EN/UL/CSA 60950-1 and 61010-1. ISO7640F and ISO7641F are quad-channel isolators; ISO7640F has four forward and ISO7641F has three forward and one reverse-direction channels. Suffix F indicates that output defaults to Low-state in fail-safe conditions (see Table 4). M-Grade devices are high-speed isolators capable of 150-Mbps data rate with fast propagation delays.

Each isolation channel has a logic input and output buffer separated by a silicon dioxide (SiO_2) insulation barrier. Used in conjunction with isolated power supplies, these devices prevent noise currents on a data bus or other circuits from entering the local ground and interfering with or damaging sensitive circuitry. The devices have TTL input thresholds and can operate from 2.7-V, 3.3-V, and 5-V supplies. All inputs are 5-V tolerant when supplied from 3.3-V or 2.7-V supplies.

Device Information⁽¹⁾

PART NUMBER	PACKAGE	BODY SIZE (NOM)
ISO7640FM	SOIC (16)	10.30 mm x 7.50 mm
ISO7641FM		

(1) For all available packages, see the orderable addendum at the end of the data sheet.

Simplified Schematic

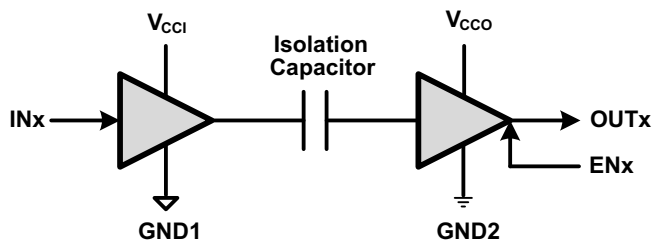

Table of Contents

1 Features	1	6.17 Switching Characteristics: V_{CC1} at 3.3 V $\pm 10\%$ and V_{CC2} at 5 V $\pm 10\%$	15
2 Applications	1	6.18 Switching Characteristics: V_{CC1} and V_{CC2} at 3.3 V $\pm 10\%$	15
3 Description	1	6.19 Switching Characteristics: V_{CC1} and V_{CC2} at 2.7 V	16
4 Revision History	2	6.20 Typical Characteristics	17
5 Pin Configuration and Functions	5	7 Parameter Measurement Information	19
6 Specifications	6	8 Detailed Description	21
6.1 Absolute Maximum Ratings	6	8.1 Overview	21
6.2 ESD Ratings	6	8.2 Functional Block Diagram	21
6.3 Recommended Operating Conditions	6	8.3 Feature Description	21
6.4 Thermal Information	6	8.4 Device Functional Modes	25
6.5 Electrical Characteristics: V_{CC1} and V_{CC2} at 5 V $\pm 10\%$	7	9 Application and Implementation	26
6.6 Electrical Characteristics: V_{CC1} at 5 V $\pm 10\%$ and V_{CC2} at 3.3 V $\pm 10\%$	7	9.1 Application Information	26
6.7 Electrical Characteristics: V_{CC1} at 3.3 V $\pm 10\%$ and V_{CC2} at 5 V $\pm 10\%$	7	9.2 Typical Application	26
6.8 Electrical Characteristics: V_{CC1} and V_{CC2} at 3.3 V $\pm 10\%$	8	10 Power Supply Recommendations	29
6.9 Electrical Characteristics: V_{CC1} and V_{CC2} at 2.7 V ...	8	11 Layout	29
6.10 Supply Current: V_{CC1} and V_{CC2} at 5 V $\pm 10\%$	9	11.1 Layout Guidelines	29
6.11 Supply Current: V_{CC1} at 5 V $\pm 10\%$ and V_{CC2} at 3.3 V $\pm 10\%$	10	11.2 Layout Example	29
6.12 Supply Current: V_{CC1} at 3.3 V $\pm 10\%$ and V_{CC2} at 5 V $\pm 10\%$	11	12 Device and Documentation Support	30
6.13 Supply Current: V_{CC1} and V_{CC2} at 3.3 V $\pm 10\%$	12	12.1 Documentation Support	30
6.14 Supply Current: V_{CC1} and V_{CC2} at 2.7 V	13	12.2 Related Links	30
6.15 Switching Characteristics: V_{CC1} and V_{CC2} at 5 V $\pm 10\%$	14	12.3 Trademarks	30
6.16 Switching Characteristics: V_{CC1} at 5 V $\pm 10\%$ and V_{CC2} at 3.3 V $\pm 10\%$	14	12.4 Electrostatic Discharge Caution	30
		12.5 Glossary	30
		13 Mechanical, Packaging, and Orderable Information	30

4 Revision History

NOTE: Page numbers for previous revisions may differ from page numbers in the current version.

Changes from Revision F (September 2013) to Revision G	Page
<ul style="list-style-type: none"> Added <i>Pin Configuration and Functions</i> section, <i>ESD Ratings</i> table, <i>Feature Description</i> section, <i>Device Functional Modes</i>, <i>Application and Implementation</i> section, <i>Power Supply Recommendations</i> section, <i>Layout</i> section, <i>Device and Documentation Support</i> section, and <i>Mechanical, Packaging, and Orderable Information</i> section VDE standard changed to DIN V VDE V 0884-10 (VDE V 0884-10):2006-12. 	1
<hr/>	
Changes from Revision E (January 2013) to Revision F	Page
<ul style="list-style-type: none"> Changed the REGULATORY INFORMATION table, TUV column From: Certificate Number: U8V 13 07 77311 009 To: Certificate Number: U8V 13 09 77311 010 	23
<hr/>	
Changes from Revision D (July 2012) to Revision E	Page
<ul style="list-style-type: none"> Changed Z to Undetermined in the OUTPUT (OUTx) column of the FUNCTION TABLE 	25

Changes from Revision C (January 2012) to Revision D	Page
• Deleted devices: ISO7631FM, ISO7631FC, ISO7640FC, ISO7641FC from the data sheet	1
• Changed the Title From: Low Power Triple and Quad Channels Digital Isolators To: Low Power Quad Channels Digital Isolators	1
• Deleted devices from the Features List	1
• Changed the DESCRIPTION	1
• Changed EN1 and EN2 Pin Descriptions	5
• Changed the ELECTRICAL, SWITCHING, and SUPPLY CURRENT CHARACTERISTICS tables	7
• Changed the ELECTRICAL, SWITCHING, and SUPPLY CURRENT CHARACTERISTICS tables	7
• Changed the ELECTRICAL, SWITCHING, and SUPPLY CURRENT CHARACTERISTICS tables	7
• Changed the ELECTRICAL, SWITCHING, and SUPPLY CURRENT CHARACTERISTICS tables	8
• Changed the ELECTRICAL, SWITCHING, and SUPPLY CURRENT CHARACTERISTICS tables	8
• Changed the TYPICAL CHARACTERISTICS section	17
• Deleted device from the Available Options Table	21
• Deleted devices from the TYPICAL SUPPLY CURRENT EQUATIONS section	28

Changes from Revision B (December 2011) to Revision C	Page
• Changed Safety and Regulatory Approvals bullet From: 6000 V _{PK} / 4243 V _{RMS} for 1 Minute per UL1577 (pending) To: 6000 V _{PK} / 4243 V _{RMS} for 1 Minute per UL 1577 (approved)	1
• Changed Description text From: The devices have TTL input thresholds and can operate from 2.7 V, 3.3 V and 5 V supplies. To: The devices have TTL input thresholds and can operate from 2.7 V (M-Grade), 3.3 V and 5 V supplies.....	1
• Changed the ESD standards	6
• Changed the typical characteristics section	17
• Deleted the Product Preview Note From the Available Options Table	21

Changes from Revision A (October 2011) to Revision B	Page
• Changed feature bullet From: ISO7641FC: 1.2 mA at 10 Mbps To: ISO7641FC: 1.3 mA at 10 Mbps	1
• Changed Safety and Regulatory Approvals bullet From: 6 KV _{PK} for 1 Minute per UL1577 and VDE (Pending) To: 6000 V _{PK} / 4243 V _{RMS} for 1 Minute per UL 1577 (pending)	1
• Changed Safety and Regulatory Approvals bullet From: To: 6000 V _{PK} / 4243 V _{RMS} for 1 Minute per UL 1577 (approved) .	1
• Changed Safety and Regulatory Approvals bullet From: CSA Component Acceptance Notice 5A, IEC 60601-1 Medical Standard (pending) To: CSA Component Acceptance Notice 5A, IEC 60601-1 Medical Standard (approved)	1
• Changed all the ELECTRICAL CHARACTERISTICS tables	7
• Changed the SWITCHING CHARACTERISTICS table ISO7640F and ISO7641F C-Grade values	9
• Changed the SWITCHING CHARACTERISTICS table ISO7640F and ISO7641F C-Grade values	10
• Changed the SWITCHING CHARACTERISTICS table ISO7640F and ISO7641F C-Grade values	11
• Changed the SWITCHING CHARACTERISTICS table ISO7640F and ISO7641F C-Grade values	12
• Changed the SWITCHING CHARACTERISTICS table ISO7640F and ISO7641F C-Grade values	13
• Changed all the SWITCHING CHARACTERISTICS tables	14
• Changed the IEC 60664-1 Ratings Table	23

Changes from Original (September 2011) to Revision A	Page
• Changed Figure 11 - From: 0 V or V _{CC} To: IN = V _{CC}	20
• Added Note (1) "Per JEDEC package dimensions" to the IEC INSULATION AND SAFETY-RELATED SPECIFICATIONS FOR DW-16 PACKAGE table	20

ISO7640FM, ISO7641FM

SLLSE89G – SEPTEMBER 2011 – REVISED JANUARY 2015

www.ti.com

• Changed L(I01) Min Value From: 8 mm To: 8.3 mm.....	20
• Changed L(I02) Min Value From: 7.8 mm To: 8.1 mm.....	20
• Added pinout for ISO7641 and ISO7631.....	28

5 Pin Configuration and Functions

**DW Package
16-Pin SOIC
Top View**

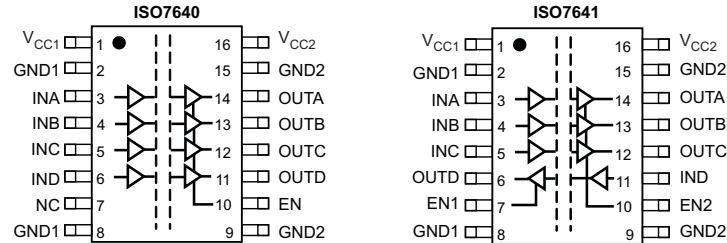

Pin Functions

NAME	PIN		I/O	DESCRIPTION
	ISO7640	ISO7641		
EN	10	-	I	Enables (when High or Open) or Disables (when Low) OUTA, OUTB, OUTC and OUTD of ISO7640
EN1	-	7	I	Enables (when High or Open) or Disables (when Low) OUTD of ISO7641
EN2	-	10	I	Enables (when High or Open) or Disables (when Low) OUTA, OUTB, and OUTC of ISO7641
GND1	2	2	-	Ground connection for V_{CC1}
	8	8		
GND2	9	9	-	Ground connection for V_{CC2}
	15	15		
INA	3	3	I	Input, channel A
INB	4	4	I	Input, channel B
INC	5	5	I	Input, channel C
IND	6	11	I	Input, channel D
NC	7	-	-	No Connect pins are floating with no internal connection
OUTA	14	14	O	Output, channel A
OUTB	13	13	O	Output, channel B
OUTC	12	12	O	Output, channel C
OUTD	11	6	O	Output, channel D
V_{CC1}	1	1	-	Power supply, V_{CC1}
V_{CC2}	16	16	-	Power supply, V_{CC2}

6 Specifications

6.1 Absolute Maximum Ratings⁽¹⁾

		MIN	MAX	UNIT
Supply voltage ⁽²⁾	V _{CC1} , V _{CC2}	-0.5	6	V
Voltage	INx, OUTx, ENx	-0.5	V _{CC} + 0.5 ⁽³⁾	V
Output Current, I _O		-15	15	mA
Maximum junction temperature, T _J			150	°C
Storage temperature, T _{stg}		-65	150	°C

- (1) Stresses beyond those listed under *Absolute Maximum Ratings* may cause permanent damage to the device. These are stress ratings only and functional operation of the device at these or any other conditions beyond those indicated under *Recommended Operating Conditions* is not implied. Exposure to absolute-maximum-rated conditions for extended periods may affect device reliability.
- (2) All voltage values except differential I/O bus voltages are with respect to the local ground terminal (GND1 or GND2) and are peak voltage values.
- (3) Maximum voltage must not exceed 6 V.

6.2 ESD Ratings

		VALUE	UNIT
V _(ESD) Electrostatic discharge	Human body model (HBM), per ANSI/ESDA/JEDEC JS-001, all pins ⁽¹⁾	±4000	V
	Charged device model (CDM), per JEDEC specification JESD22-C101, all pins ⁽²⁾	±1500	
	Machine model, per JEDEC JESD22-A115-A	±200	

- (1) JEDEC document JEP155 states that 500-V HBM allows safe manufacturing with a standard ESD control process.
- (2) JEDEC document JEP157 states that 250-V CDM allows safe manufacturing with a standard ESD control process.

6.3 Recommended Operating Conditions

		MIN	NOM	MAX	UNIT
V _{CC1} , V _{CC2}	Supply voltage	2.7		5.5	V
I _{OH}	High-level output current	-4			mA
I _{OL}	Low-level output current			4	mA
V _{IH}	High-level input voltage	2		5.5	V
V _{IL}	Low-level input voltage	0		0.8	V
t _{ui}	Input pulse duration	≥3-V Operation		6.67	ns
		<3-V Operation		10	
1 / t _{ui}	Signaling rate	≥3-V Operation		150	Mbps
		<3-V Operation		100	
T _J	Junction temperature	-40		136	°C
T _A	Ambient temperature	-40	25	125	°C

6.4 Thermal Information

THERMAL METRIC ⁽¹⁾		ISO76xx	UNIT
		DW (SOIC)	
		16 PINS	
R _{θJA}	Junction-to-ambient thermal resistance	72	°C/W
R _{θJC(top)}	Junction-to-case(top) thermal resistance	38	
R _{θJB}	Junction-to-board thermal resistance	39	
Ψ _{JT}	Junction-to-top characterization parameter	9.4	
P _D	Maximum Device Power Dissipation	V _{CC1} = V _{CC2} = 5.5V, T _J = 150°C, C _L = 15 pF Input a 75-MHz 50% duty cycle square wave	
		399	mW

- (1) For more information about traditional and new thermal metrics, see the *IC Package Thermal Metrics* application report, [SPRA953](#).

6.5 Electrical Characteristics: V_{CC1} and V_{CC2} at 5 V \pm 10%

 V_{CC1} and V_{CC2} at 5 V \pm 10% (over recommended operating conditions unless otherwise noted)

PARAMETER	TEST CONDITIONS	MIN	TYP	MAX	UNIT
V_{OH} High-level output voltage	$I_{OH} = -4$ mA; see Figure 9	$V_{CCO}^{(1)} - 0.8$	4.8		V
	$I_{OH} = -20$ μ A; see Figure 9	$V_{CCO}^{(1)} - 0.1$	5		
V_{OL} Low-level output voltage	$I_{OL} = 4$ mA; see Figure 9		0.2	0.4	V
	$I_{OL} = 20$ μ A; see Figure 9		0	0.1	
$V_{I(HYS)}$ Input threshold voltage hysteresis			450		mV
I_{IH} High-level input current	$V_{IH} = V_{CC}$ at INx or ENx			10	μ A
I_{IL} Low-level input current	$V_{IL} = 0$ V at INx or ENx	-10			
CMTI Common-mode transient immunity	$V_I = V_{CC}$ or 0 V; see Figure 12	25	75		kV/ μ s

 (1) V_{CCO} is the supply voltage, V_{CC1} or V_{CC2} , for the output channel that is being measured.

6.6 Electrical Characteristics: V_{CC1} at 5 V \pm 10% and V_{CC2} at 3.3 V \pm 10%

 V_{CC1} at 5 V \pm 10% and V_{CC2} at 3.3 V \pm 10% (over recommended operating conditions unless otherwise noted)

PARAMETER	TEST CONDITIONS	MIN	TYP	MAX	UNIT
V_{OH} High-level output voltage	$I_{OH} = -4$ mA; see Figure 9	OUTx on V_{CC1} (5V) side	$V_{CC1} - 0.8$	4.8	V
		OUTx on V_{CC2} (3.3V) side	$V_{CC2} - 0.4$	3	
	$I_{OH} = -20$ μ A; see Figure 9	OUTx on V_{CC1} (5V) side	$V_{CC1} - 0.1$	5	
		OUTx on V_{CC2} (3.3V) side	$V_{CC2} - 0.1$	3.3	
V_{OL} Low-level output voltage	$I_{OL} = 4$ mA; see Figure 9		0.2	0.4	V
	$I_{OL} = 20$ μ A; see Figure 9		0	0.1	
$V_{I(HYS)}$ Input threshold voltage hysteresis			430		mV
I_{IH} High-level input current	$V_{IH} = V_{CC}$ at INx or ENx			10	μ A
I_{IL} Low-level input current	$V_{IL} = 0$ V at INx or ENx	-10			
CMTI Common-mode transient immunity	$V_I = V_{CC}$ or 0 V; see Figure 12	25	50		kV/ μ s

6.7 Electrical Characteristics: V_{CC1} at 3.3 V \pm 10% and V_{CC2} at 5 V \pm 10%

 V_{CC1} at 3.3 V \pm 10% and V_{CC2} at 5 V \pm 10% (over recommended operating conditions unless otherwise noted)

PARAMETER	TEST CONDITIONS	MIN	TYP	MAX	UNIT
V_{OH} High-level output voltage	$I_{OH} = -4$ mA; see Figure 9	OUTx on V_{CC1} (3.3 V) side	$V_{CC1} - 0.4$	3	V
		OUTx on V_{CC2} (5 V) side	$V_{CC2} - 0.8$	4.8	
	$I_{OH} = -20$ μ A; see Figure 9	OUTx on V_{CC1} (3.3 V) side	$V_{CC1} - 0.1$	3.3	
		OUTx on V_{CC2} (5 V) side	$V_{CC2} - 0.1$	5	
V_{OL} Low-level output voltage	$I_{OL} = 4$ mA; see Figure 9		0.2	0.4	V
	$I_{OL} = 20$ μ A; see Figure 9		0	0.1	
$V_{I(HYS)}$ Input threshold voltage hysteresis			430		mV
I_{IH} High-level input current	$V_{IH} = V_{CC}$ at INx or ENx			10	μ A
I_{IL} Low-level input current	$V_{IL} = 0$ V at INx or ENx	-10			
CMTI Common-mode transient immunity	$V_I = V_{CC}$ or 0 V; see Figure 12	25	50		kV/ μ s

6.8 Electrical Characteristics: V_{CC1} and V_{CC2} at 3.3 V $\pm 10\%$

 V_{CC1} and V_{CC2} at 3.3 V $\pm 10\%$ (over recommended operating conditions unless otherwise noted)

PARAMETER		TEST CONDITIONS	MIN	TYP	MAX	UNIT
V_{OH}	High-level output voltage	$I_{OH} = -4$ mA; see Figure 9	$V_{CCO}^{(1)} - 0.4$	3		V
		$I_{OH} = -20$ μ A; see Figure 9	$V_{CCO}^{(1)} - 0.1$	3.3		
V_{OL}	Low-level output voltage	$I_{OL} = 4$ mA; see Figure 9		0.2	0.4	V
		$I_{OL} = 20$ μ A; see Figure 9		0	0.1	
$V_{I(HYS)}$	Input threshold voltage hysteresis			425		mV
I_{IH}	High-level input current	$V_{IH} = V_{CC}$ at INx or ENx			10	μ A
I_{IL}	Low-level input current	$V_{IL} = 0$ V at INx or ENx	-10			
CMTI	Common-mode transient immunity	$V_I = V_{CC}$ or 0 V; see Figure 12	25	50		kV/ μ s

(1) V_{CCO} is the supply voltage, V_{CC1} or V_{CC2} , for the output channel that is being measured.

6.9 Electrical Characteristics: V_{CC1} and V_{CC2} at 2.7 V

 V_{CC1} and V_{CC2} at 2.7 V⁽¹⁾ (over recommended operating conditions unless otherwise noted)

PARAMETER		TEST CONDITIONS	MIN	TYP	MAX	UNIT
V_{OH}	High-level output voltage	$I_{OH} = -4$ mA; see Figure 9	$V_{CCO}^{(2)} - 0.5$	2.4		V
		$I_{OH} = -20$ μ A; see Figure 9	$V_{CCO}^{(2)} - 0.1$	2.7		
V_{OL}	Low-level output voltage	$I_{OL} = 4$ mA; see Figure 9		0.2	0.4	V
		$I_{OL} = 20$ μ A; see Figure 9		0	0.1	
$V_{I(HYS)}$	Input threshold voltage hysteresis			350		mV
I_{IH}	High-level input current	$V_{IH} = V_{CC}$ at INx or ENx			10	μ A
I_{IL}	Low-level input current	$V_{IL} = 0$ V at INx or ENx	-10			
CMTI	Common-mode transient immunity	$V_I = V_{CC}$ or 0 V; see Figure 12	25	50		kV/ μ s

(1) For 2.7-V operation, max data rate is 100 Mbps.

(2) V_{CCO} is the supply voltage, V_{CC1} or V_{CC2} , for the output channel that is being measured.

6.10 Supply Current: V_{CC1} and V_{CC2} at 5 V $\pm 10\%$

V_{CC1} and V_{CC2} at 5 V $\pm 10\%$ (over recommended operating conditions unless otherwise noted)

PARAMETER	TEST CONDITIONS		MIN	TYP	MAX	UNIT	
ISO7640FM							
I_{CC1}	Disable	EN = 0 V		0.6	1.2	mA	
I_{CC2}				4.5	6.6		
I_{CC1}	DC to 1 Mbps	DC Signal: $V_I = V_{CC}$ or 0 V, AC Signal: All channels switching with square wave clock input; $C_L = 15$ pF		0.7	1.3		
I_{CC2}				4.6	6.7		
I_{CC1}	10 Mbps			1.1	2		
I_{CC2}				6.6	10.5		
I_{CC1}	25 Mbps			1.9	3		
I_{CC2}				9.7	14.7		
I_{CC1}	150 Mbps			8.2	14.5		
I_{CC2}				35	58		
ISO7641FM							
I_{CC1}	Disable		EN1 = EN2 = 0 V		2.6	4.2	mA
I_{CC2}				4.2	6.8		
I_{CC1}	DC to 1 Mbps	DC Signal: $V_I = V_{CC}$ or 0 V, AC Signal: All channels switching with square wave clock input; $C_L = 15$ pF		2.7	4.3		
I_{CC2}				4.3	6.9		
I_{CC1}	10 Mbps			3.6	4.9		
I_{CC2}				6	8.2		
I_{CC1}	25 Mbps			5.1	6.6		
I_{CC2}				8.8	11.4		
I_{CC1}	150 Mbps			17	22		
I_{CC2}				31	42		

ISO7640FM, ISO7641FM

SLLSE89G – SEPTEMBER 2011 – REVISED JANUARY 2015

www.ti.com
6.11 Supply Current: V_{CC1} at 5 V $\pm 10\%$ and V_{CC2} at 3.3 V $\pm 10\%$
 V_{CC1} at 5 V $\pm 10\%$ and V_{CC2} at 3.3 V $\pm 10\%$ (over recommended operating conditions unless otherwise noted)

PARAMETER	TEST CONDITIONS		MIN	TYP	MAX	UNIT		
ISO7640FM								
I_{CC1}	Disable	EN = 0 V		0.6	1.2	mA		
I_{CC2}				3.6	5.1			
I_{CC1}	DC to 1 Mbps	DC Signal: $V_I = V_{CC}$ or 0 V, AC Signal: All channels switching with square wave clock input; $C_L = 15$ pF		0.7	1.3			
I_{CC2}				3.7	5.2			
I_{CC1}	10 Mbps			1.1	2			
I_{CC2}				5	7.1			
I_{CC1}	25 Mbps			1.9	3			
I_{CC2}				6.9	11			
I_{CC1}	150 Mbps			8.2	14.5			
I_{CC2}				24	40			
ISO7641FM								
I_{CC1}	Disable		EN1 = EN2 = 0 V		2.6		4.2	
I_{CC2}					3.2		4.9	
I_{CC1}	DC to 1 Mbps		DC Signal: $V_I = V_{CC}$ or 0 V, AC Signal: All channels switching with square wave clock input; $C_L = 15$ pF		2.7		4.3	
I_{CC2}					3.3		5	
I_{CC1}	10 Mbps				3.6		4.9	
I_{CC2}					4.4	5.8		
I_{CC1}	25 Mbps				5.1	6.6		
I_{CC2}				6.1	7.6			
I_{CC1}	150 Mbps			17	22			
I_{CC2}				20.6	26.5			

6.12 Supply Current: V_{CC1} at 3.3 V $\pm 10\%$ and V_{CC2} at 5 V $\pm 10\%$

V_{CC1} at 3.3 V $\pm 10\%$ and V_{CC2} at 5 V $\pm 10\%$ (over recommended operating conditions unless otherwise noted)

PARAMETER		TEST CONDITIONS	MIN	TYP	MAX	UNIT		
ISO7640FM								
I_{CC1}	Disable	EN = 0 V		0.35	0.7	mA		
I_{CC2}				4.5	6.6			
I_{CC1}	DC to 1 Mbps	DC Signal: $V_I = V_{CC}$ or 0 V, AC Signal: All channels switching with square wave clock input; $C_L = 15$ pF		0.4	0.8			
I_{CC2}				4.6	6.7			
I_{CC1}	10 Mbps			0.7	1.2			
I_{CC2}				6.6	10.5			
I_{CC1}	25 Mbps			1.1	2			
I_{CC2}				9.7	14.7			
I_{CC1}	150 Mbps			5	8.5			
I_{CC2}				35	58			
ISO7641FM								
I_{CC1}	Disable		EN1 = EN2 = 0 V		1.9		2.9	mA
I_{CC2}				4.2	6.8			
I_{CC1}	DC to 1 Mbps	DC Signal: $V_I = V_{CC}$ or 0 V, AC Signal: All channels switching with square wave clock input; $C_L = 15$ pF		2	3			
I_{CC2}				4.3	6.9			
I_{CC1}	10 Mbps			2.5	3.5			
I_{CC2}				6	8.2			
I_{CC1}	25 Mbps			3.4	4.5			
I_{CC2}				8.8	11.4			
I_{CC1}	150 Mbps			10.5	14.5			
I_{CC2}				31	42			

ISO7640FM, ISO7641FM

SLLSE89G – SEPTEMBER 2011 – REVISED JANUARY 2015

www.ti.com
6.13 Supply Current: V_{CC1} and V_{CC2} at 3.3 V \pm 10%
 V_{CC1} and V_{CC2} at 3.3 V \pm 10% (over recommended operating conditions unless otherwise noted)

PARAMETER		TEST CONDITIONS	MIN	TYP	MAX	UNIT		
ISO7640FM								
I_{CC1}	Disable	EN = 0 V		0.35	0.7	mA		
I_{CC2}				3.6	5.1			
I_{CC1}	DC to 1 Mbps	DC Signal: $V_I = V_{CC}$ or 0 V, AC Signal: All channels switching with square wave clock input; $C_L = 15$ pF		0.4	0.8			
I_{CC2}				3.7	5.2			
I_{CC1}	10 Mbps			0.7	1.2			
I_{CC2}				5	7.1			
I_{CC1}	25 Mbps			1.1	2			
I_{CC2}				6.9	11			
I_{CC1}	150 Mbps			5	8.5			
I_{CC2}				24	40			
ISO7641FM								
I_{CC1}	Disable		EN1 = EN2 = 0 V		1.9		2.9	
I_{CC2}				3.2	4.9			
I_{CC1}	DC to 1 Mbps	DC Signal: $V_I = V_{CC}$ or 0 V, AC Signal: All channels switching with square wave clock input; $C_L = 15$ pF		2	3			
I_{CC2}				3.3	5			
I_{CC1}	10 Mbps			2.5	3.5			
I_{CC2}				4.4	5.8			
I_{CC1}	25 Mbps			3.4	4.5			
I_{CC2}				6.1	7.6			
I_{CC1}	150 Mbps			10.5	14.5			
I_{CC2}				20.6	26.5			

6.14 Supply Current: V_{CC1} and V_{CC2} at 2.7 V

 V_{CC1} and V_{CC2} at 2.7 V (over recommended operating conditions unless otherwise noted)

PARAMETER	TEST CONDITIONS		MIN	TYP	MAX	UNIT	
ISO7640FM							
I_{CC1}	Disable	EN = 0 V		0.2	0.6	mA	
I_{CC2}			3.3	5			
I_{CC1}	DC to 1 Mbps	DC Signal: $V_I = V_{CC}$ or 0 V, AC Signal: All channels switching with square wave clock input; $C_L = 15$ pF		0.2	0.7		
I_{CC2}			3.4	5.1			
I_{CC1}	10 Mbps		0.4	1.1			
I_{CC2}			4.4	6.8			
I_{CC1}	25 Mbps		0.8	1.8			
I_{CC2}			6	9.5			
I_{CC1}	100 Mbps		2.7	5			
I_{CC2}			14.2	21			
ISO7641FM							
I_{CC1}	Disable		EN1 = EN2 = 0 V		1.6	2.4	mA
I_{CC2}		2.8		4.1			
I_{CC1}	DC to 1 Mbps	DC Signal: $V_I = V_{CC}$ or 0 V, AC Signal: All channels switching with square wave clock input; $C_L = 15$ pF		1.7	2.5		
I_{CC2}			2.9	4.2			
I_{CC1}	10 Mbps		2.1	3			
I_{CC2}			3.8	5			
I_{CC1}	25 Mbps		2.8	3.8			
I_{CC2}			5.2	6.7			
I_{CC1}	100 Mbps		6.4	7.5			
I_{CC2}			11.8	15.5			

6.15 Switching Characteristics: V_{CC1} and V_{CC2} at 5 V $\pm 10\%$

 V_{CC1} and V_{CC2} at 5 V $\pm 10\%$ (over recommended operating conditions unless otherwise noted)

PARAMETER		TEST CONDITIONS	MIN	TYP	MAX	UNIT	
t_{PLH} , t_{PHL}	Propagation delay time	See Figure 9	3.5	7	10.5	ns	
PWD ⁽¹⁾	Pulse width distortion $ t_{PHL} - t_{PLH} $						
$t_{sk(o)}$ ⁽²⁾	Channel-to-channel output skew time	Same-direction Channels			2		
		Opposite-direction Channels			3		
$t_{sk(pp)}$ ⁽³⁾	Part-to-part skew time				4.5		
t_r	Output signal rise time	See Figure 9		1.6			ns
t_f	Output signal fall time			1			
t_{PHZ}	Disable Propagation Delay, high-to-high impedance output	See Figure 10		5	16		ns
t_{PLZ}	Disable Propagation Delay, low-to-high impedance output			5	16		
t_{PZH}	Enable Propagation Delay, high impedance-to-high output			4	16		
t_{PZL}	Enable Propagation Delay, high impedance-to-low output			4	16		
t_{fs}	Fail-safe output delay time from input data or power loss	See Figure 11		9.5		μ s	

(1) Also known as Pulse Skew.

(2) $t_{sk(o)}$ is the skew between outputs of a single device with all driving inputs connected together and the outputs switching in the same direction while driving identical loads.

(3) $t_{sk(pp)}$ is the magnitude of the difference in propagation delay times between any terminals of different devices switching in the same direction while operating at identical supply voltages, temperature, input signals and loads.

6.16 Switching Characteristics: V_{CC1} at 5 V $\pm 10\%$ and V_{CC2} at 3.3 V $\pm 10\%$

 V_{CC1} at 5 V $\pm 10\%$ and V_{CC2} at 3.3 V $\pm 10\%$ (over recommended operating conditions unless otherwise noted)

PARAMETER		TEST CONDITIONS	MIN	TYP	MAX	UNIT	
t_{PLH} , t_{PHL}	Propagation delay time	See Figure 9	4	8	13	ns	
PWD ⁽¹⁾	Pulse width distortion $ t_{PHL} - t_{PLH} $						
$t_{sk(o)}$ ⁽²⁾	Channel-to-channel output skew time	Same-direction Channels			2.5		
		Opposite-direction Channels			3.5		
$t_{sk(pp)}$ ⁽³⁾	Part-to-part skew time				6		
t_r	Output signal rise time	See Figure 9		2			ns
t_f	Output signal fall time			1.2			
t_{PHZ}	Disable Propagation Delay, high-to-high impedance output	See Figure 10		6.5	17		ns
t_{PLZ}	Disable Propagation Delay, low-to-high impedance output			6.5	17		
t_{PZH}	Enable Propagation Delay, high impedance-to-high output			5.5	17		
t_{PZL}	Enable Propagation Delay, high impedance-to-low output			5.5	17		
t_{fs}	Fail-safe output delay time from input data or power loss	See Figure 11		9.5		μ s	

(1) Also known as Pulse Skew.

(2) $t_{sk(o)}$ is the skew between outputs of a single device with all driving inputs connected together and the outputs switching in the same direction while driving identical loads.

(3) $t_{sk(pp)}$ is the magnitude of the difference in propagation delay times between any terminals of different devices switching in the same direction while operating at identical supply voltages, temperature, input signals and loads.

6.17 Switching Characteristics: V_{CC1} at 3.3 V $\pm 10\%$ and V_{CC2} at 5 V $\pm 10\%$

V_{CC1} at 3.3 V $\pm 10\%$ and V_{CC2} at 5 V $\pm 10\%$ (over recommended operating conditions unless otherwise noted)

PARAMETER		TEST CONDITIONS	MIN	TYP	MAX	UNIT
t_{PLH} , t_{PHL}	Propagation delay time	See Figure 9	4	7.5	12.5	ns
PWD ⁽¹⁾	Pulse width distortion $ t_{PHL} - t_{PLH} $					
$t_{sk(o)}$ ⁽²⁾	Channel-to-channel output skew time	Same-direction Channels			2.5	
		Opposite-direction Channels			3.5	
$t_{sk(pp)}$ ⁽³⁾	Part-to-part skew time				6	
t_r	Output signal rise time	See Figure 9		1.7		
t_f	Output signal fall time			1.1		
t_{PHZ}	Disable Propagation Delay, high-to-high impedance output	See Figure 10		5.5	17	
t_{PLZ}	Disable Propagation Delay, low-to-high impedance output			5.5	17	
t_{PZH}	Enable Propagation Delay, high impedance-to-high output			4.5	17	
t_{PZL}	Enable Propagation Delay, high impedance-to-low output			4.5	17	
t_{fs}	Fail-safe output delay time from input data or power loss	See Figure 11		9.5		μ s

(1) Also known as Pulse Skew.

(2) $t_{sk(o)}$ is the skew between outputs of a single device with all driving inputs connected together and the outputs switching in the same direction while driving identical loads.

(3) $t_{sk(pp)}$ is the magnitude of the difference in propagation delay times between any terminals of different devices switching in the same direction while operating at identical supply voltages, temperature, input signals and loads.

6.18 Switching Characteristics: V_{CC1} and V_{CC2} at 3.3 V $\pm 10\%$

V_{CC1} and V_{CC2} at 3.3 V $\pm 10\%$ (over recommended operating conditions unless otherwise noted)

PARAMETER		TEST CONDITIONS	MIN	TYP	MAX	UNIT
t_{PLH} , t_{PHL}	Propagation delay time	See Figure 9	4	8.5	14	ns
PWD ⁽¹⁾	Pulse width distortion $ t_{PHL} - t_{PLH} $					
$t_{sk(o)}$ ⁽²⁾	Channel-to-channel output skew time	Same-direction Channels			3	
		Opposite-direction Channels			4	
$t_{sk(pp)}$ ⁽³⁾	Part-to-part skew time				6.5	
t_r	Output signal rise time	See Figure 9		2		
t_f	Output signal fall time			1.3		
t_{PHZ}	Disable Propagation Delay, high-to-high impedance output	See Figure 10		6.5	17	
t_{PLZ}	Disable Propagation Delay, low-to-high impedance output			6.5	17	
t_{PZH}	Enable Propagation Delay, high impedance-to-high output			5.5	17	
t_{PZL}	Enable Propagation Delay, high impedance-to-low output			5.5	17	
t_{fs}	Fail-safe output delay time from input data or power loss	See Figure 11		9.2		μ s

(1) Also known as Pulse Skew.

(2) $t_{sk(o)}$ is the skew between outputs of a single device with all driving inputs connected together and the outputs switching in the same direction while driving identical loads.

(3) $t_{sk(pp)}$ is the magnitude of the difference in propagation delay times between any terminals of different devices switching in the same direction while operating at identical supply voltages, temperature, input signals and loads.

6.19 Switching Characteristics: V_{CC1} and V_{CC2} at 2.7 V

 V_{CC1} and V_{CC2} at 2.7 V (over recommended operating conditions unless otherwise noted)

PARAMETER		TEST CONDITIONS	MIN	TYP	MAX	UNIT
t_{PLH} , t_{PHL}	Propagation delay time	See Figure 9	5	8	16	ns
PWD ⁽¹⁾	Pulse width distortion $ t_{PHL} - t_{PLH} $		2.5			
$t_{sk(o)}$ ⁽²⁾	Channel-to-channel output skew time	Same-direction Channels			4	ns
		Opposite-direction Channels			5	
$t_{sk(pp)}$ ⁽³⁾	Part-to-part skew time				8	
t_r	Output signal rise time	See Figure 9		2.3		ns
t_f	Output signal fall time			1.8		
t_{PHZ}	Disable Propagation Delay, high-to-high impedance output	See Figure 10		8	18	ns
t_{PLZ}	Disable Propagation Delay, low-to-high impedance output			8	18	
t_{PZH}	Enable Propagation Delay, high impedance-to-high output			7	18	
t_{PZL}	Enable Propagation Delay, high impedance-to-low output			7	18	
t_{fs}	Fail-safe output delay time from input data or power loss	See Figure 11		8.5		μ s

(1) Also known as Pulse Skew.

(2) $t_{sk(o)}$ is the skew between outputs of a single device with all driving inputs connected together and the outputs switching in the same direction while driving identical loads.

(3) $t_{sk(pp)}$ is the magnitude of the difference in propagation delay times between any terminals of different devices switching in the same direction while operating at identical supply voltages, temperature, input signals and loads.

6.20 Typical Characteristics

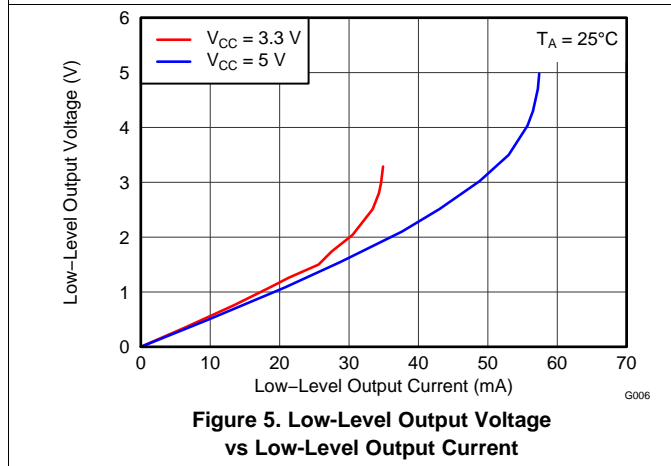
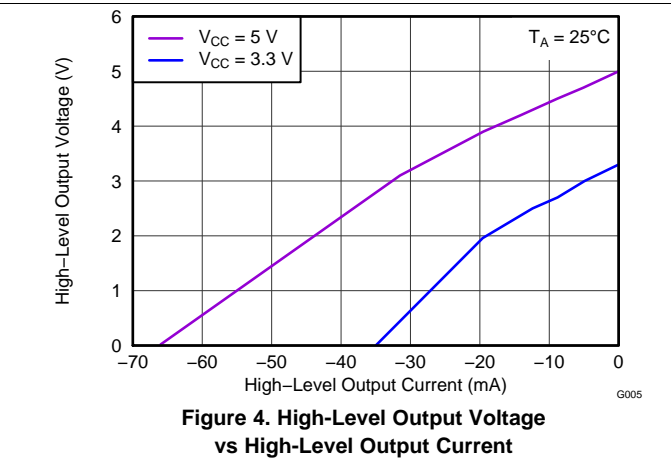
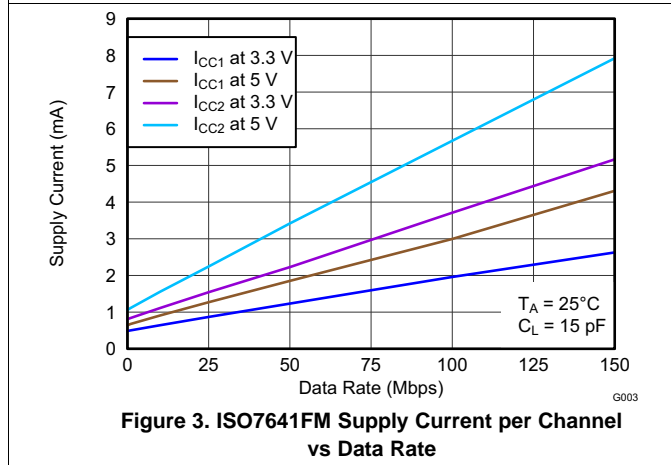
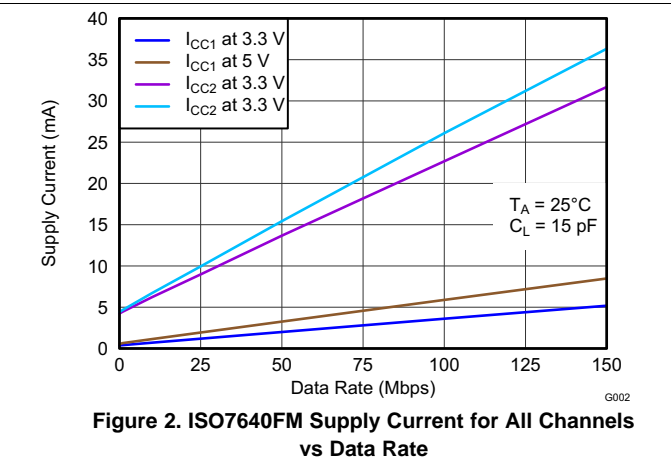
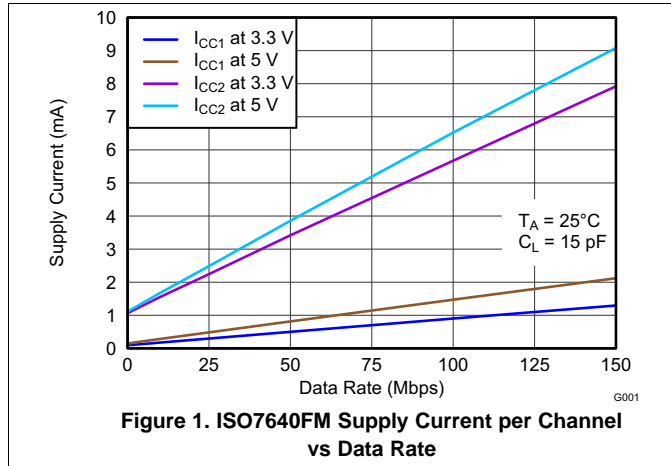

Typical Characteristics (continued)

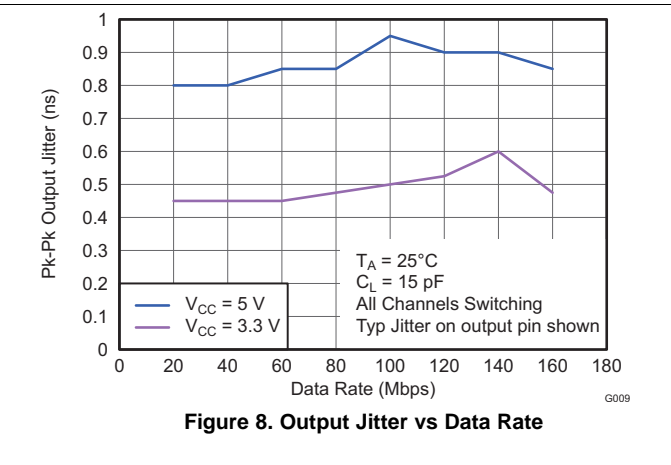
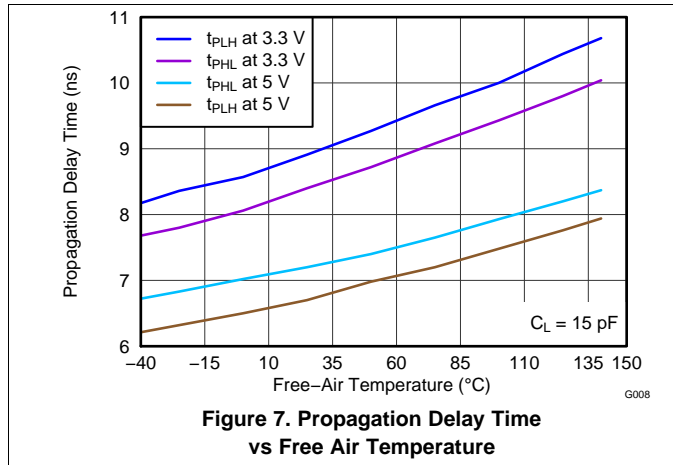

7 Parameter Measurement Information

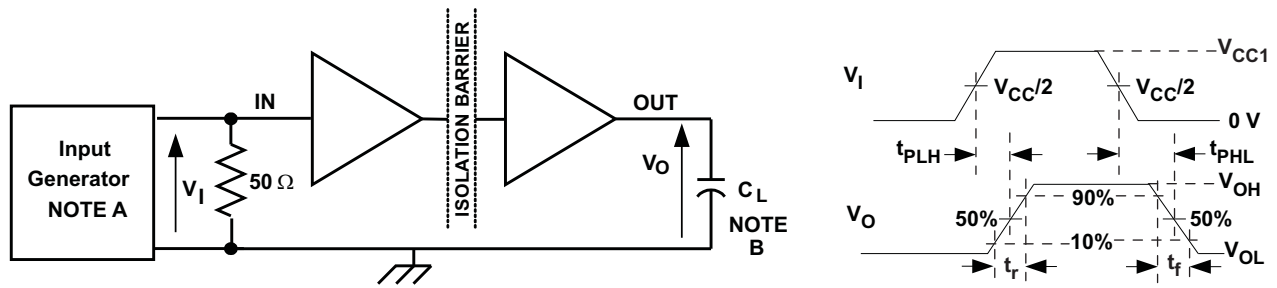

- The input pulse is supplied by a generator having the following characteristics: PRR \leq 50 kHz, 50% duty cycle, $t_r \leq 3$ ns, $t_f \leq 3$ ns, $Z_O = 50 \Omega$. At the input, 50- Ω resistor is required to terminate Input Generator signal. It is not needed in actual application.
- $C_L = 15$ pF and includes instrumentation and fixture capacitance within $\pm 20\%$.

Figure 9. Switching Characteristics Test Circuit and Voltage Waveforms

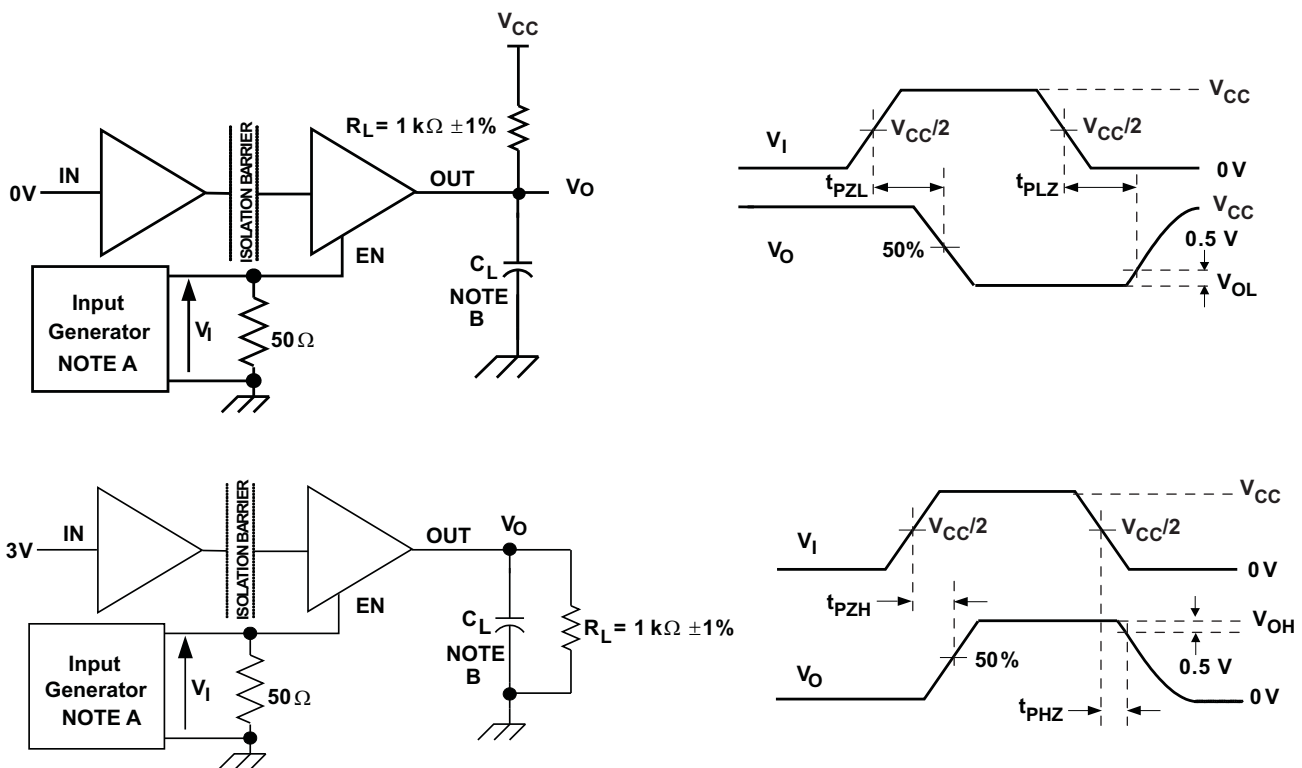

- The input pulse is supplied by a generator having the following characteristics: PRR \leq 10 kHz, 50% duty cycle, $t_r \leq 3$ ns, $t_f \leq 3$ ns, $Z_O = 50 \Omega$.
- $C_L = 15$ pF and includes instrumentation and fixture capacitance within $\pm 20\%$.

Figure 10. Enable/Disable Propagation Delay Time Test Circuit and Waveform

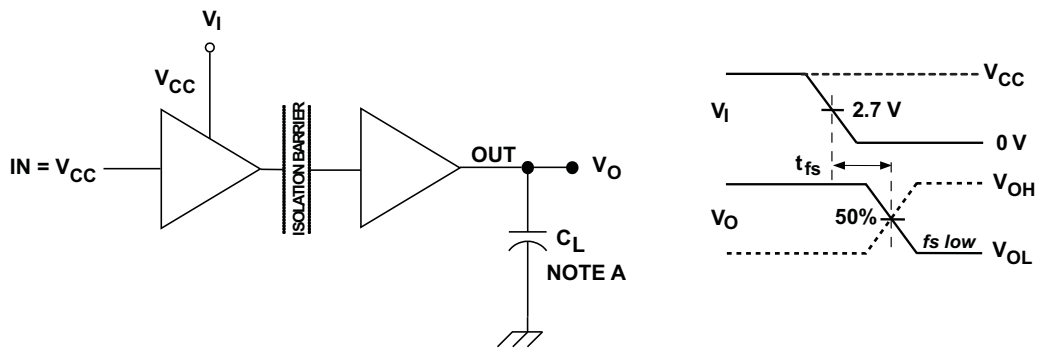
Parameter Measurement Information (continued)

- A. $C_L = 15 \text{ pF}$ and includes instrumentation and fixture capacitance within $\pm 20\%$.

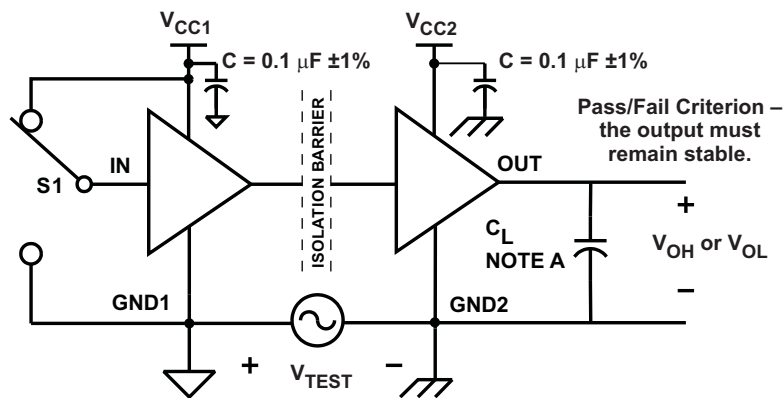
Figure 11. Fail-Safe Delay Time Test Circuit and Voltage Waveforms

- A. $C_L = 15 \text{ pF}$ and includes instrumentation and fixture capacitance within $\pm 20\%$.

Figure 12. Common-Mode Transient Immunity Test Circuit

8 Detailed Description

8.1 Overview

The isolator in [Figure 13](#) is based on a capacitive isolation barrier technique. The I/O channel of the device consists of two internal data channels, a high-frequency channel (HF) with a bandwidth from 100 kbps up to 150 Mbps, and a low-frequency channel (LF) covering the range from 100 kbps down to DC. In principle, a single-ended input signal entering the HF-channel is split into a differential signal via the inverter gate at the input. The following capacitor-resistor networks differentiate the signal into transients, which then are converted into differential pulses by two comparators. The comparator outputs drive a NOR-gate flip-flop whose output feeds an output multiplexer. A decision logic (DCL) at the driving output of the flip-flop measures the durations between signal transients. If the duration between two consecutive transients exceeds a certain time limit, (as in the case of a low-frequency signal), the DCL forces the output-multiplexer to switch from the high- to the low-frequency channel.

Because low-frequency input signals require the internal capacitors to assume prohibitively large values, these signals are pulse-width modulated (PWM) with the carrier frequency of an internal oscillator, thus creating a sufficiently high frequency signal, capable of passing the capacitive barrier. As the input is modulated, a low-pass filter (LPF) is needed to remove the high-frequency carrier from the actual data before passing it on to the output multiplexer.

8.2 Functional Block Diagram

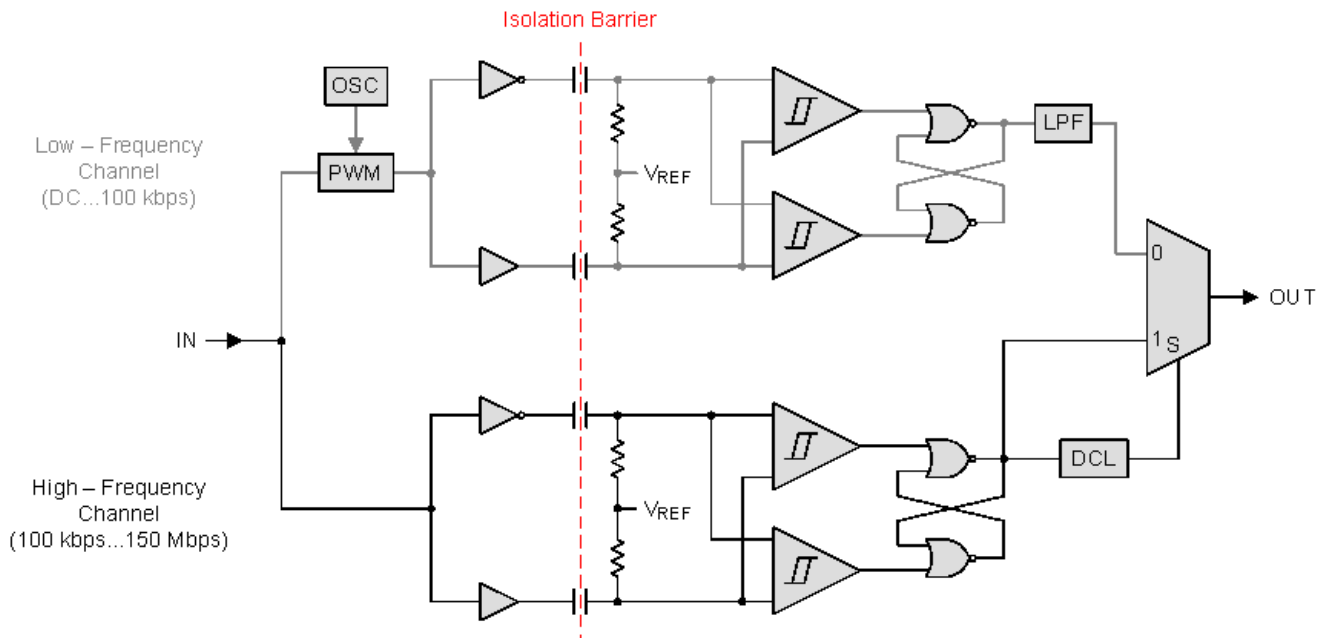

Figure 13. Conceptual Block Diagram of a Digital Capacitive Isolator

8.3 Feature Description

PRODUCT	RATED ISOLATION	PACKAGE	INPUT THRESHOLD	DATA RATE, INPUT FILTER	CHANNEL DIRECTION
ISO7640FM	6 KV _{PK} / 5 KV _{RMS} ⁽¹⁾	DW-16	1.5 V TTL	150 Mbps, No Noise Filter	4 Forward, 0 Reverse
ISO7641FM					3 Forward, 1 Reverse

(1) See the [Table 2](#) table for detailed isolation ratings.

8.3.1 IEC Insulation and Safety-Related Specifications for DW-16 Package

PARAMETER		TEST CONDITIONS	MIN	TYP	MAX	UNIT
L(I01)	Minimum air gap (Clearance)	Shortest terminal to terminal distance through air	8.3			mm
L(I02) ⁽¹⁾	Minimum external tracking (Creepage)	Shortest terminal to terminal distance across the package surface	8.1			mm
CTI	Tracking resistance (Comparative Tracking Index)	DIN IEC 60112 / VDE 0303 Part 1	≥400			V
	Minimum Internal Gap (Internal Clearance)	Distance through the insulation	0.014			mm
R _{IO} ⁽²⁾	Isolation resistance, Input to Output	V _{IO} = 500 V, T _A = 25°C		>10 ¹²		Ω
		V _{IO} = 500 V, 100°C ≤ T _A ≤ T _A max		>10 ¹¹		
C _{IO} ⁽²⁾	Barrier capacitance, Input to Output	V _I = 0.4 sin (2πft), f = 1MHz		2		pF
C _I ⁽³⁾	Input capacitance	V _I = V _{CC} /2 + 0.4 sin (2πft), f = 1MHz, V _{CC} = 5 V		2		pF

- (1) Per JEDEC package dimensions.
 (2) All pins on each side of the barrier tied together creating a two-terminal device.
 (3) Measured from input pin to ground.

NOTE

Creepage and clearance requirements should be applied according to the specific equipment isolation standards of an application. Care should be taken to maintain the creepage and clearance distance of a board design to ensure that the mounting pads of the isolator on the printed-circuit-board (PCB) do not reduce this distance.

Creepage and clearance on a PCB become equal according to the measurement techniques shown in the Isolation Glossary. Techniques such as inserting grooves and/or ribs on a PCB are used to help increase these specifications.

8.3.2 DIN V VDE V 0884-10 (VDE V 0884-10) Insulation Characteristics

over recommended operating conditions (unless otherwise noted)⁽⁴⁾

PARAMETER		TEST CONDITIONS	SPECIFICATION	UNIT
V _{IORM}	Maximum working insulation voltage		1414	V _{PEAK}
V _{PR}	Input-to-output test voltage	After Input/Output safety test subgroup 2/3, V _{PR} = V _{IORM} × 1.2, t = 10 s, Partial discharge < 5 pC	1697	V _{PEAK}
		Method a, After environmental tests subgroup 1, V _{PR} = V _{IORM} × 1.6, t = 10 s, Partial Discharge < 5 pC	2262	
		Method b1, 100% Production test V _{PR} = V _{IORM} × 1.875, t = 1 s Partial discharge < 5 pC	2652	
V _{IOTM}	Maximum transient overvoltage	V _{TEST} = V _{IOTM} t = 60 sec (Qualification) t = 1 sec (100% Production)	6000	V _{PEAK}
R _S	Insulation resistance	V _{IO} = 500 V at T _S	>10 ⁹	Ω
	Pollution degree		2	

- (4) Climatic Classification 40/125/21

Table 1. IEC 60664-1 Ratings Table

PARAMETER	TEST CONDITIONS	SPECIFICATION
Basic Isolation Group	Material Group	II
Installation classification	Rated mains voltage $\leq 300 V_{RMS}$	I–IV
	Rated mains voltage $\leq 600 V_{RMS}$	I–III
	Rated mains voltage $\leq 1000 V_{RMS}$	I–II

Table 2. Regulatory Information

VDE	TUV	CSA	UL	CQC
Certified according to DIN V VDE V 0884-10 (VDE V 0084-10):2006-12	Certified according to EN/UL/CSA 60950-1 and EN/UL/CSA 61010-1	Approved under CSA Component Acceptance Notice 5A, IEC 61010-1, IEC 60950-1, IEC 60601-1	Recognized under UL 1577 Component Recognition Program	Certified according to GB4943.1-2011
Basic Insulation, Maximum Transient Overvoltage, $6000 V_{PK}$, Maximum Working Voltage, $1414 V_{PK}$	$5000 V_{RMS}$ Isolation Rating, Reinforced Insulation, $400 V_{RMS}$ maximum working voltage, Basic Insulation, $600 V_{RMS}$ maximum working voltage	$5000 V_{RMS}$ Isolation Rating, $380 V_{RMS}$ Reinforced and $760 V_{RMS}$ Basic working voltage per CSA 60950-1-07 and IEC 60950-1 (2nd Ed.), $300 V_{RMS}$ Reinforced and $600 V_{RMS}$ Basic working voltage per CSA 61010-1-04 and IEC 61010-1 (2nd Ed.), 2 Means of Patient Protection at $125 V_{RMS}$ per CSA 60601-1:08 and IEC 60601-1 (3rd Ed.)	Single Protection, $4243 V_{RMS}^{(1)}$	Reinforced Insulation, Altitude ≤ 5000 m, Tropical Climate, $250 V_{RMS}$ maximum working voltage
Certificate number: 40016131	Certificate number: U8V 13 09 77311 010	Master contract number: 220991	File Number: E181974	Certificate number: CQC14001109542

(1) Production tested $\geq 5092 V_{RMS}$ for 1 second in accordance with UL 1577.

8.3.3 Safety Limiting Values

Safety limiting intends to prevent potential damage to the isolation barrier upon failure of input or output circuitry. A failure of the IO can allow low resistance to ground or the supply and, without current limiting, dissipate sufficient power to overheat the die and damage the isolation barrier potentially leading to secondary system failures.

Table 3. Safety Limiting Values

PARAMETER	TEST CONDITIONS			MIN	TYP	MAX	UNIT	
I _S Safety input, output, or supply current	DW-16	$\theta_{JA} = 72^{\circ}\text{C/W}$, $V_I = 5.5\text{ V}$, $T_J = 150^{\circ}\text{C}$, $T_A = 25^{\circ}\text{C}$					316	mA
		$\theta_{JA} = 72^{\circ}\text{C/W}$, $V_I = 3.6\text{ V}$, $T_J = 150^{\circ}\text{C}$, $T_A = 25^{\circ}\text{C}$					482	
		$\theta_{JA} = 72^{\circ}\text{C/W}$, $V_I = 2.7\text{ V}$, $T_J = 150^{\circ}\text{C}$, $T_A = 25^{\circ}\text{C}$					643	
T _S Maximum case temperature						150	°C	

The safety-limiting constraint is the absolute maximum junction temperature specified in the absolute maximum ratings table. The power dissipation and junction-to-air thermal impedance of the device installed in the application hardware determines the junction temperature. The assumed junction-to-air thermal resistance in the [Thermal Information](#) table is that of a device installed on a High-K Test Board for Leaded Surface Mount Packages. The power is the recommended maximum input voltage times the current. The junction temperature is then the ambient temperature plus the power times the junction-to-air thermal resistance.

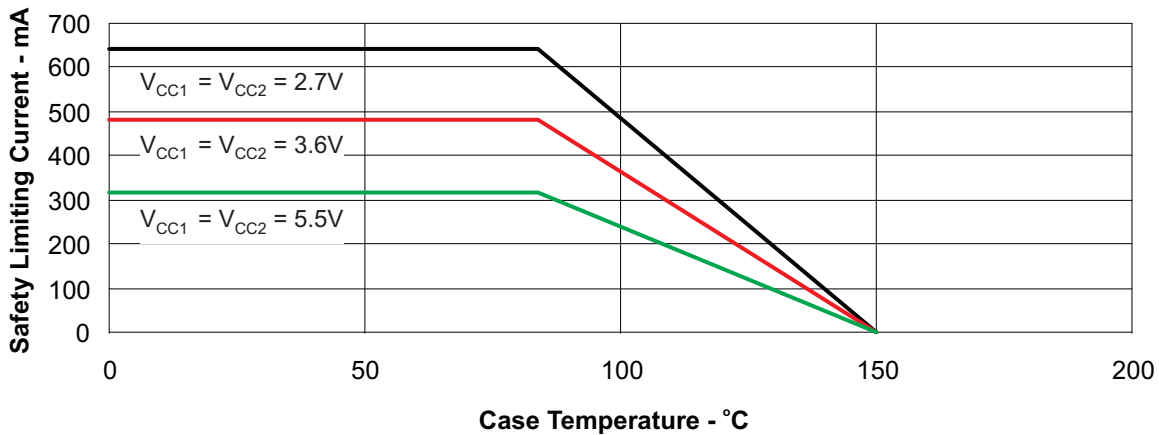

Figure 14. DW-16 θ_{JC} Thermal Derating Curve per DIN V VDE V 0884-10

8.4 Device Functional Modes

Table 4. Function Table⁽¹⁾

V _{CCI}	V _{CCO}	INPUT (IN _x)	OUTPUT ENABLE (EN _x)	OUTPUT (OUT _x)
PU	PU	H	H or Open	H
		L	H or Open	L
		X	L	Z
		Open	H or Open	L
PD	PU	X	H or Open	L
PD	PU	X	L	Z
X	PD	X	X	Undetermined

(1) V_{CCI} = Input-side V_{CC}; V_{CCO} = Output-side V_{CC}; PU = Powered Up (V_{CC} ≥ 2.7 V); PD = Powered Down (V_{CC} ≤ 2.1 V); X = Irrelevant; H = High Level; L = Low Level; Z = High Impedance

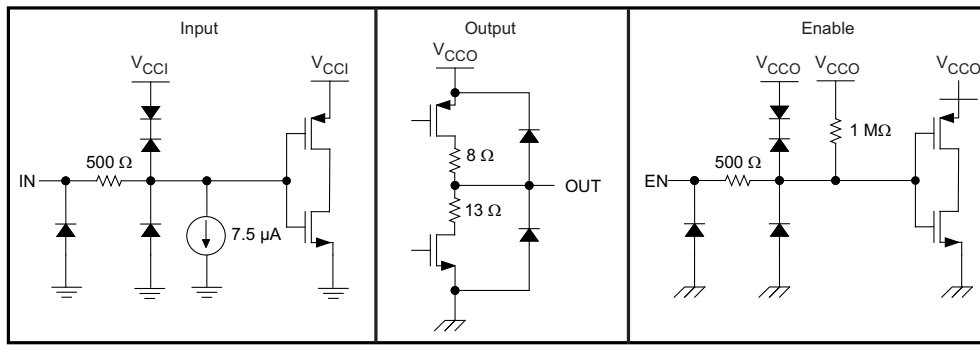

Figure 15. Device I/O Schematics

9 Application and Implementation

NOTE

Information in the following applications sections is not part of the TI component specification, and TI does not warrant its accuracy or completeness. TI's customers are responsible for determining suitability of components for their purposes. Customers should validate and test their design implementation to confirm system functionality.

9.1 Application Information

ISO764x use single-ended TTL-logic switching technology. Its supply voltage range is from 3 V to 5.5 V for both supplies, V_{CC1} and V_{CC2} . When designing with digital isolators, it is important to note that due to the single-ended design structure, digital isolators do not conform to any specific interface standard and are only intended for isolating single-ended CMOS or TTL digital signal lines. The isolator is typically placed between the data controller (that is, μ C or UART), and a data converter or a line transceiver, regardless of the interface type or standard.

9.2 Typical Application

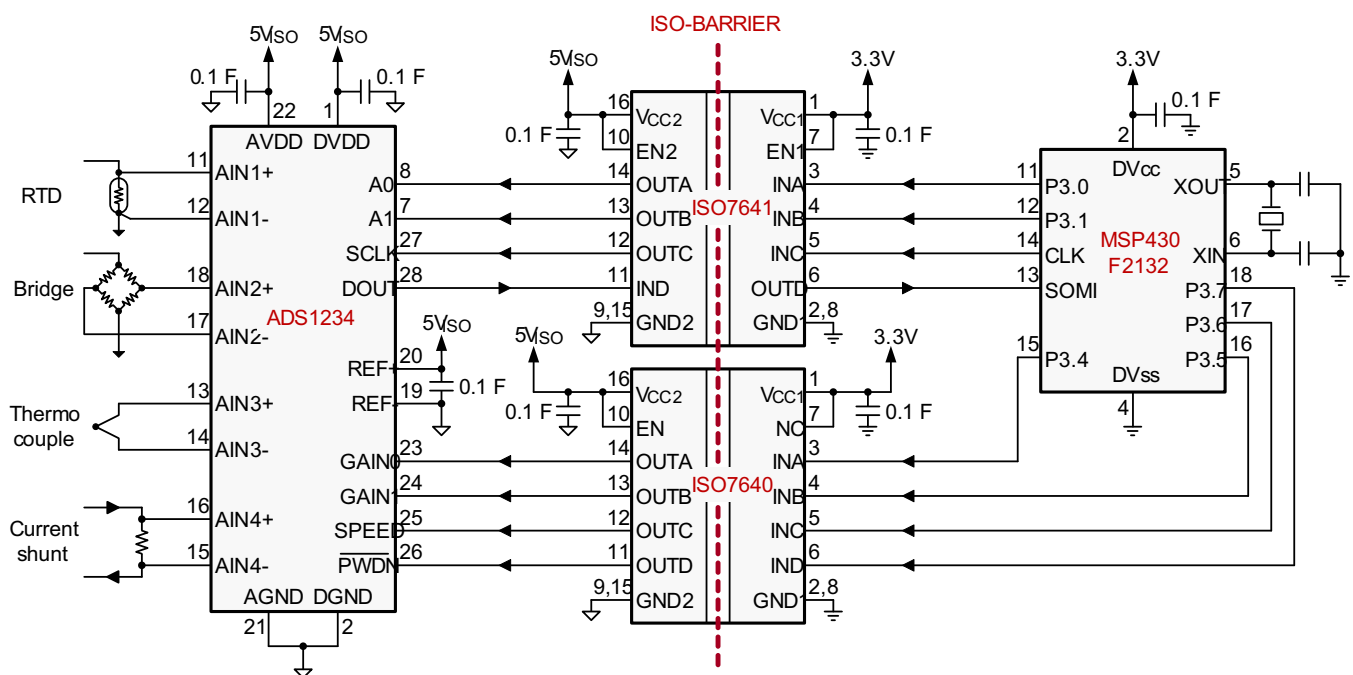

Figure 16. Isolated Data Acquisition System for Process Control

9.2.1 Design Requirements

Unlike optocouplers, which require external components to improve performance, provide bias, or limit current, the ISO764x device only requires two external bypass capacitors to operate.

Typical Application (continued)

9.2.2 Detailed Design Procedure

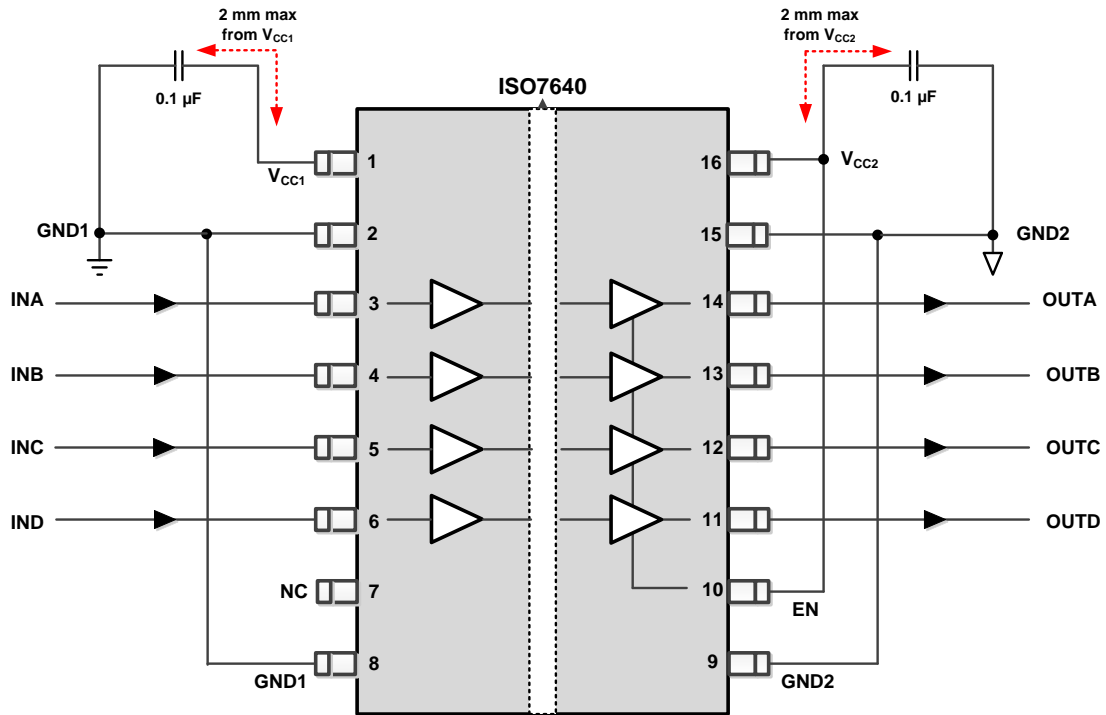

Figure 17. Typical ISO7640FM Circuit Hookup

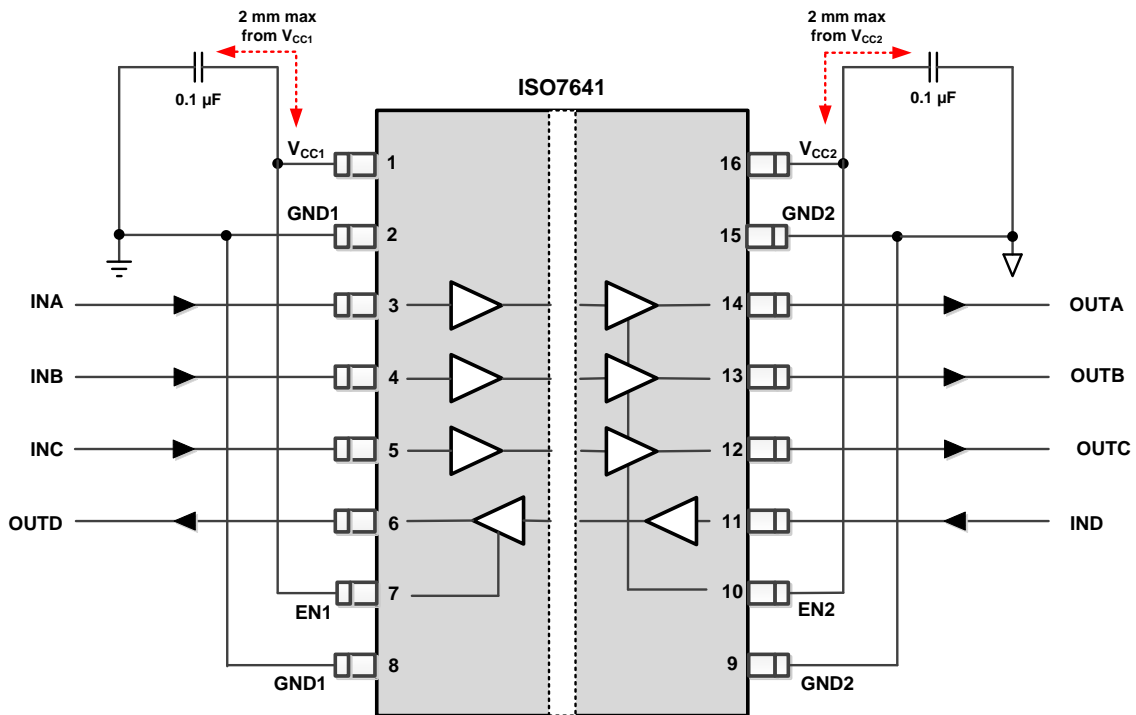

Figure 18. Typical ISO7641FM Circuit Hookup

Typical Application (continued)

9.2.2.1 Typical Supply Current Equations

(Calculated based on room temperature and typical Silicon process)

ISO7640FM:

At $V_{CC1} = V_{CC2} = 3.3\text{ V}$

$$I_{CC1} = 0.388 + 0.0312 \times f \tag{1}$$

$$I_{CC2} = 3.39 + 0.03561 \times f + 0.006588 \times f \times C_L \tag{2}$$

At $V_{CC1} = V_{CC2} = 5\text{ V}$

$$I_{CC1} = 0.584 + 0.05349 \times f \tag{3}$$

$$I_{CC2} = 4.184 + 0.05597 \times f + 0.009771 \times f \times C_L \tag{4}$$

ISO7641FM:

At $V_{CC1} = V_{CC2} = 3.3\text{ V}$

$$I_{CC1} = 1.848 + 0.03233 \times f + 0.001645 \times f \times C_L \tag{5}$$

$$I_{CC2} = 3.005 + 0.03459 \times f + 0.0049395 \times f \times C_L \tag{6}$$

At $V_{CC1} = V_{CC2} = 5\text{ V}$

$$I_{CC1} = 2.369 + 0.05385 \times f + 0.002448 \times f \times C_L \tag{7}$$

$$I_{CC2} = 3.857 + 0.05506 \times f + 0.007348 \times f \times C_L \tag{8}$$

I_{CC1} and I_{CC2} are typical supply currents measured in mA; f is data rate measured in Mbps; C_L is the capacitive load on each channel measured in pF.

9.2.3 Application Curves

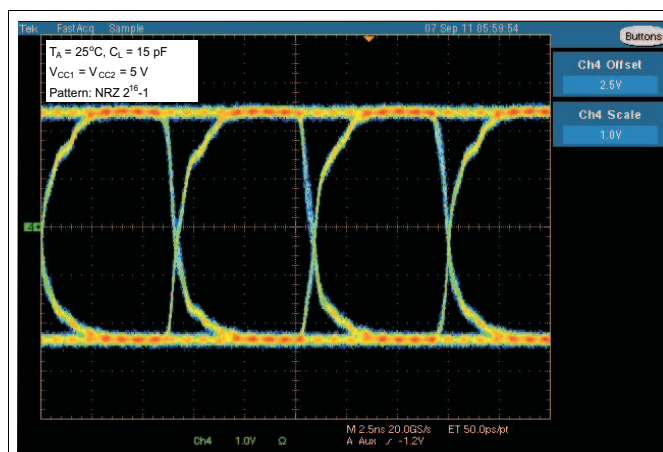

Figure 19. Typical Eye Diagram at 150 Mbps, 5-V Operation

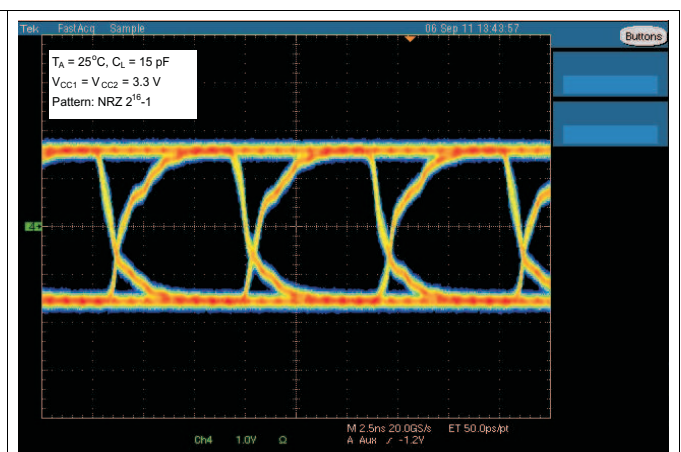

Figure 20. Typical Eye Diagram at 150 Mbps, 3.3-V Operation

10 Power Supply Recommendations

To ensure reliable operation at all data rates and supply voltages, a 0.1- μ F bypass capacitor is recommended at input and output supply pins (V_{CC1} and V_{CC2}). The capacitors should be placed as close to the supply pins as possible. If only a single primary-side power supply is available in an application, isolated power can be generated for the secondary-side with the help of a transformer driver such as Texas Instruments' [SN6501](#). For such applications, detailed power supply design and transformer selection recommendations are available in SN6501 data sheet ([SLLSEA0](#)).

11 Layout

11.1 Layout Guidelines

A minimum of four layers is required to accomplish a low EMI PCB design (see [Figure 21](#)). Layer stacking should be in the following order (top-to-bottom): high-speed signal layer, ground plane, power plane and low-frequency signal layer.

- Routing the high-speed traces on the top layer avoids the use of vias (and the introduction of their inductances) and allows for clean interconnects between the isolator and the transmitter and receiver circuits of the data link.
- Placing a solid ground plane next to the high-speed signal layer establishes controlled impedance for transmission line interconnects and provides an excellent low-inductance path for the return current flow.
- Placing the power plane next to the ground plane creates additional high-frequency bypass capacitance of approximately 100 pF/in².
- Routing the slower speed control signals on the bottom layer allows for greater flexibility as these signal links usually have margin to tolerate discontinuities such as vias.

If an additional supply voltage plane or signal layer is needed, add a second power and ground plane system to the stack to keep it symmetrical. This makes the stack mechanically stable and prevents it from warping. Also the power and ground plane of each power system can be placed closer together, thus increasing the high-frequency bypass capacitance significantly.

NOTE

For detailed layout recommendations, see *Digital Isolator Design Guide*, [SLLA284](#).

11.2 Layout Example

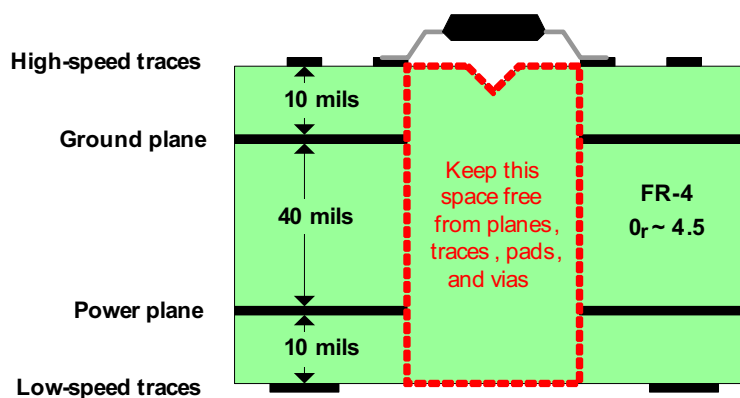

Figure 21. Recommended Layer Stack

12 Device and Documentation Support

12.1 Documentation Support

12.1.1 Related Documentation

For related documentation, see the following:

- *Digital Isolator Design Guide*, [SLLA284](#)
- *Transformer Driver for Isolated Power Supplies*, [SLLSEAO](#)

12.2 Related Links

The table below lists quick access links. Categories include technical documents, support and community resources, tools and software, and quick access to sample or buy.

Table 5. Related Links

PARTS	PRODUCT FOLDER	SAMPLE & BUY	TECHNICAL DOCUMENTS	TOOLS & SOFTWARE	SUPPORT & COMMUNITY
ISO7640FM	Click here	Click here	Click here	Click here	Click here
ISO7641FM	Click here	Click here	Click here	Click here	Click here

12.3 Trademarks

DeviceNet is a trademark of DeviceNet Open Vendors Association. All other trademarks are the property of their respective owners.

12.4 Electrostatic Discharge Caution



These devices have limited built-in ESD protection. The leads should be shorted together or the device placed in conductive foam during storage or handling to prevent electrostatic damage to the MOS gates.

12.5 Glossary

[SLYZ022](#) — *TI Glossary*.

This glossary lists and explains terms, acronyms, and definitions.

[SLLA353](#) -- *Isolation Glossary*.

13 Mechanical, Packaging, and Orderable Information

The following pages include mechanical, packaging, and orderable information. This information is the most current data available for the designated devices. This data is subject to change without notice and revision of this document. For browser-based versions of this data sheet, refer to the left-hand navigation.

PACKAGING INFORMATION

Orderable Device	Status (1)	Package Type	Package Drawing	Pins	Package Qty	Eco Plan (2)	Lead finish/ Ball material (6)	MSL Peak Temp (3)	Op Temp (°C)	Device Marking (4/5)	Samples
ISO7640FMDW	ACTIVE	SOIC	DW	16	40	RoHS & Green	NIPDAU	Level-3-260C-168 HR	-40 to 125	ISO7640FM	Samples
ISO7640FMDWR	ACTIVE	SOIC	DW	16	2000	RoHS & Green	NIPDAU	Level-3-260C-168 HR	-40 to 125	ISO7640FM	Samples
ISO7641FMDW	ACTIVE	SOIC	DW	16	40	RoHS & Green	NIPDAU	Level-3-260C-168 HR	-40 to 125	ISO7641FM	Samples
ISO7641FMDWR	ACTIVE	SOIC	DW	16	2000	RoHS & Green	NIPDAU	Level-3-260C-168 HR	-40 to 125	ISO7641FM	Samples

(1) The marketing status values are defined as follows:

ACTIVE: Product device recommended for new designs.

LIFEBUY: TI has announced that the device will be discontinued, and a lifetime-buy period is in effect.

NRND: Not recommended for new designs. Device is in production to support existing customers, but TI does not recommend using this part in a new design.

PREVIEW: Device has been announced but is not in production. Samples may or may not be available.

OBSOLETE: TI has discontinued the production of the device.

(2) **RoHS:** TI defines "RoHS" to mean semiconductor products that are compliant with the current EU RoHS requirements for all 10 RoHS substances, including the requirement that RoHS substance do not exceed 0.1% by weight in homogeneous materials. Where designed to be soldered at high temperatures, "RoHS" products are suitable for use in specified lead-free processes. TI may reference these types of products as "Pb-Free".

RoHS Exempt: TI defines "RoHS Exempt" to mean products that contain lead but are compliant with EU RoHS pursuant to a specific EU RoHS exemption.

Green: TI defines "Green" to mean the content of Chlorine (Cl) and Bromine (Br) based flame retardants meet JS709B low halogen requirements of <=1000ppm threshold. Antimony trioxide based flame retardants must also meet the <=1000ppm threshold requirement.

(3) MSL, Peak Temp. - The Moisture Sensitivity Level rating according to the JEDEC industry standard classifications, and peak solder temperature.

(4) There may be additional marking, which relates to the logo, the lot trace code information, or the environmental category on the device.

(5) Multiple Device Markings will be inside parentheses. Only one Device Marking contained in parentheses and separated by a "-" will appear on a device. If a line is indented then it is a continuation of the previous line and the two combined represent the entire Device Marking for that device.

(6) Lead finish/Ball material - Orderable Devices may have multiple material finish options. Finish options are separated by a vertical ruled line. Lead finish/Ball material values may wrap to two lines if the finish value exceeds the maximum column width.

Important Information and Disclaimer:The information provided on this page represents TI's knowledge and belief as of the date that it is provided. TI bases its knowledge and belief on information provided by third parties, and makes no representation or warranty as to the accuracy of such information. Efforts are underway to better integrate information from third parties. TI has taken and

continues to take reasonable steps to provide representative and accurate information but may not have conducted destructive testing or chemical analysis on incoming materials and chemicals. TI and TI suppliers consider certain information to be proprietary, and thus CAS numbers and other limited information may not be available for release.

In no event shall TI's liability arising out of such information exceed the total purchase price of the TI part(s) at issue in this document sold by TI to Customer on an annual basis.

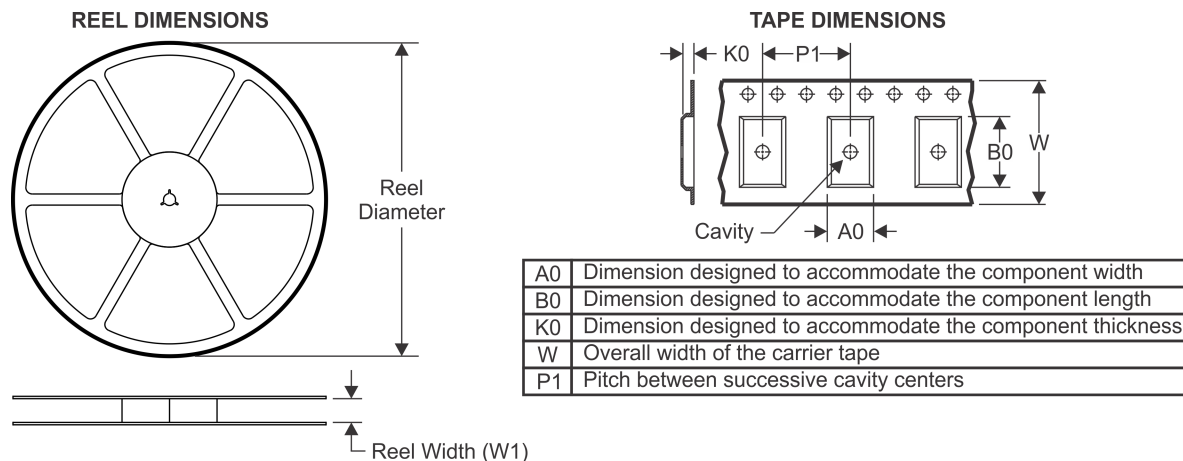
TAPE AND REEL INFORMATION

QUADRANT ASSIGNMENTS FOR PIN 1 ORIENTATION IN TAPE



*All dimensions are nominal

Device	Package Type	Package Drawing	Pins	SPQ	Reel Diameter (mm)	Reel Width W1 (mm)	A0 (mm)	B0 (mm)	K0 (mm)	P1 (mm)	W (mm)	Pin1 Quadrant
ISO7640FMDWR	SOIC	DW	16	2000	330.0	16.4	10.75	10.7	2.7	12.0	16.0	Q1
ISO7641FMDWR	SOIC	DW	16	2000	330.0	16.4	10.75	10.7	2.7	12.0	16.0	Q1

TAPE AND REEL BOX DIMENSIONS

*All dimensions are nominal

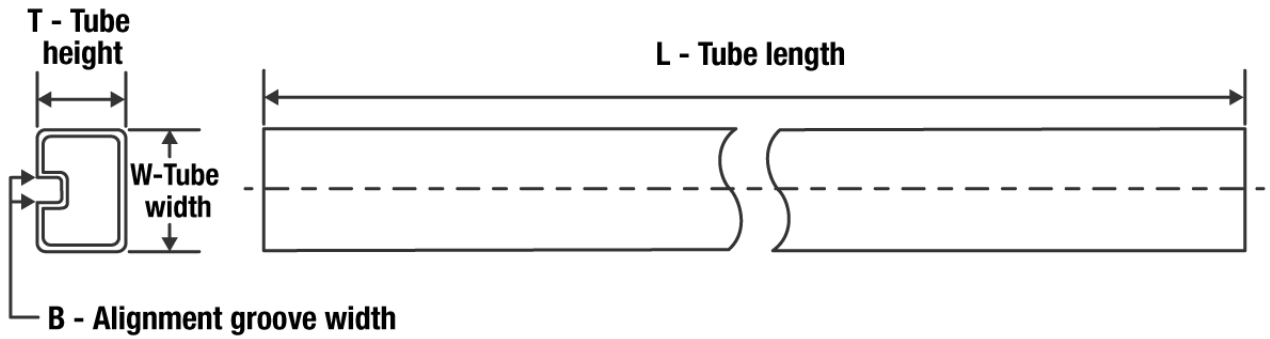
Device	Package Type	Package Drawing	Pins	SPQ	Length (mm)	Width (mm)	Height (mm)
ISO7640FMDWR	SOIC	DW	16	2000	350.0	350.0	43.0
ISO7641FMDWR	SOIC	DW	16	2000	350.0	350.0	43.0

TUBE

*All dimensions are nominal

Device	Package Name	Package Type	Pins	SPQ	L (mm)	W (mm)	T (μm)	B (mm)
ISO7640FMDW	DW	SOIC	16	40	506.98	12.7	4826	6.6
ISO7641FMDW	DW	SOIC	16	40	506.98	12.7	4826	6.6

GENERIC PACKAGE VIEW

DW 16

SOIC - 2.65 mm max height

7.5 x 10.3, 1.27 mm pitch

SMALL OUTLINE INTEGRATED CIRCUIT

This image is a representation of the package family, actual package may vary.
Refer to the product data sheet for package details.

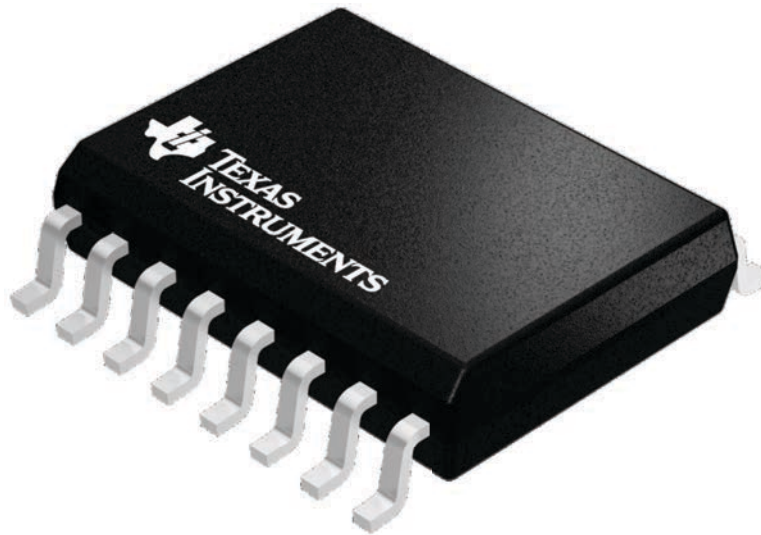

4224780/A

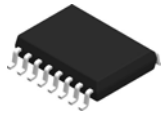

DW0016B

PACKAGE OUTLINE

SOIC - 2.65 mm max height

SOIC

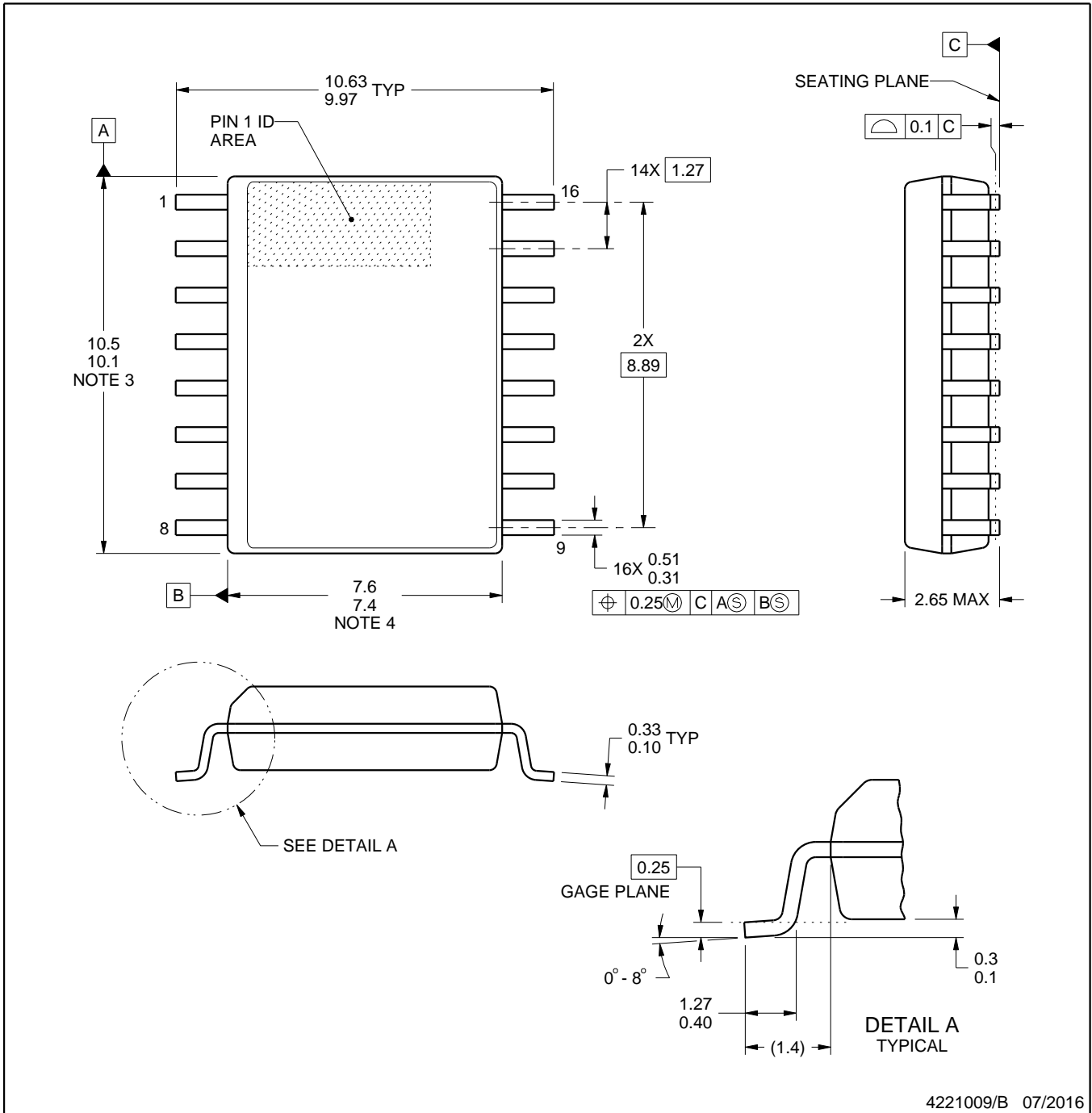

4221009/B 07/2016

EXAMPLE BOARD LAYOUT

DW0016B

SOIC - 2.65 mm max height

SOIC

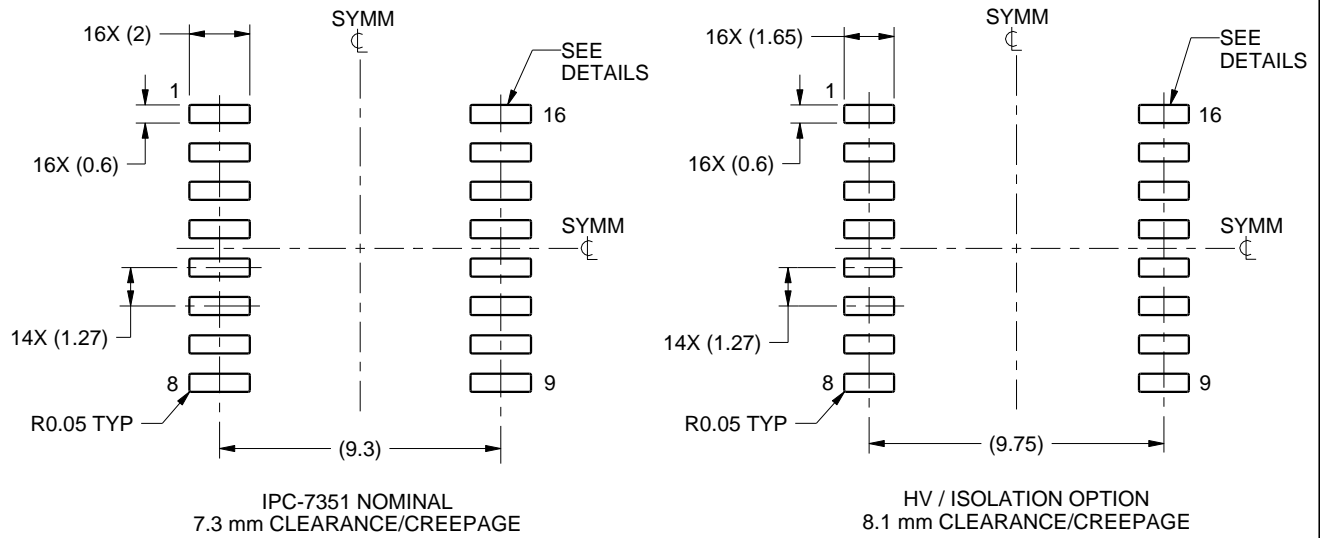

LAND PATTERN EXAMPLE
SCALE:4X

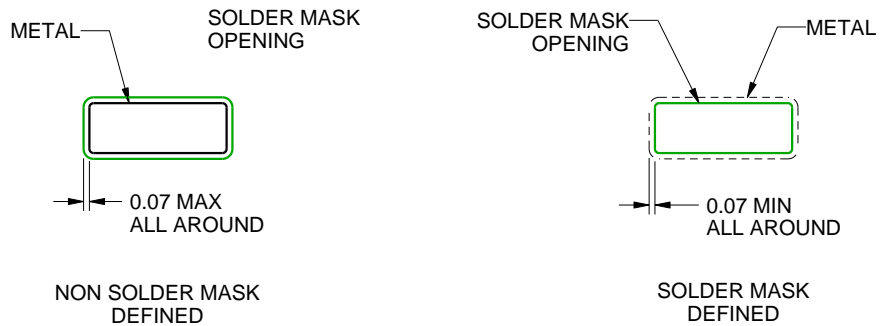

SOLDER MASK DETAILS

4221009/B 07/2016

NOTES: (continued)

- 6. Publication IPC-7351 may have alternate designs.
- 7. Solder mask tolerances between and around signal pads can vary based on board fabrication site.

EXAMPLE STENCIL DESIGN

DW0016B

SOIC - 2.65 mm max height

SOIC

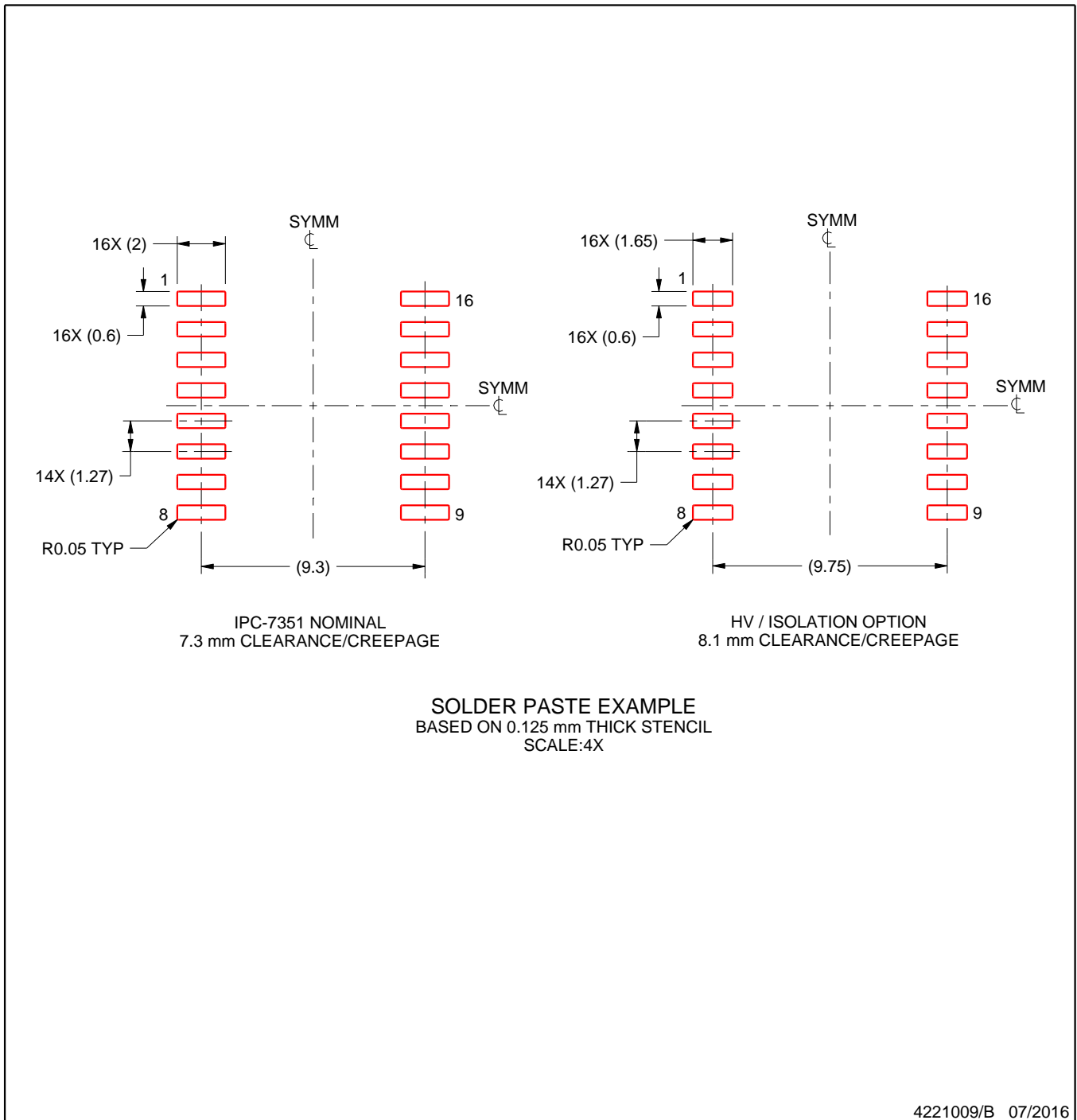

NOTES: (continued)

8. Laser cutting apertures with trapezoidal walls and rounded corners may offer better paste release. IPC-7525 may have alternate design recommendations.
9. Board assembly site may have different recommendations for stencil design.

IMPORTANT NOTICE AND DISCLAIMER

TI PROVIDES TECHNICAL AND RELIABILITY DATA (INCLUDING DATA SHEETS), DESIGN RESOURCES (INCLUDING REFERENCE DESIGNS), APPLICATION OR OTHER DESIGN ADVICE, WEB TOOLS, SAFETY INFORMATION, AND OTHER RESOURCES "AS IS" AND WITH ALL FAULTS, AND DISCLAIMS ALL WARRANTIES, EXPRESS AND IMPLIED, INCLUDING WITHOUT LIMITATION ANY IMPLIED WARRANTIES OF MERCHANTABILITY, FITNESS FOR A PARTICULAR PURPOSE OR NON-INFRINGEMENT OF THIRD PARTY INTELLECTUAL PROPERTY RIGHTS.

These resources are intended for skilled developers designing with TI products. You are solely responsible for (1) selecting the appropriate TI products for your application, (2) designing, validating and testing your application, and (3) ensuring your application meets applicable standards, and any other safety, security, regulatory or other requirements.

These resources are subject to change without notice. TI grants you permission to use these resources only for development of an application that uses the TI products described in the resource. Other reproduction and display of these resources is prohibited. No license is granted to any other TI intellectual property right or to any third party intellectual property right. TI disclaims responsibility for, and you will fully indemnify TI and its representatives against, any claims, damages, costs, losses, and liabilities arising out of your use of these resources.

TI's products are provided subject to [TI's Terms of Sale](#) or other applicable terms available either on [ti.com](https://www.ti.com) or provided in conjunction with such TI products. TI's provision of these resources does not expand or otherwise alter TI's applicable warranties or warranty disclaimers for TI products.

TI objects to and rejects any additional or different terms you may have proposed.

Mailing Address: Texas Instruments, Post Office Box 655303, Dallas, Texas 75265
Copyright © 2024, Texas Instruments Incorporated

Looking for pricing, stock, or lifecycle information?

Click below to explore more details on WIN SOURCE:

 [View ISO7640FMDW](#) on WIN SOURCE

 [Texas Instruments](#) Information

Optimize Your Supply Chain with WIN SOURCE Solutions

-  Global Sourcing Solution
-  Obsolete Management
-  Cost Control Management
-  Shortage Management
-  Alternative Solution
-  Excess Inventory Management