



**THE DATASHEET OF
NCS6415DWR2G**



ON Semiconductor

Is Now

onsemi™

To learn more about onsemi™, please visit our website at
www.onsemi.com

onsemi and **onsemi** and other names, marks, and brands are registered and/or common law trademarks of Semiconductor Components Industries, LLC dba "**onsemi**" or its affiliates and/or subsidiaries in the United States and/or other countries. **onsemi** owns the rights to a number of patents, trademarks, copyrights, trade secrets, and other intellectual property. A listing of **onsemi** product/patent coverage may be accessed at www.onsemi.com/site/pdf/Patent-Marking.pdf. **onsemi** reserves the right to make changes at any time to any products or information herein, without notice. The information herein is provided "as-is" and **onsemi** makes no warranty, representation or guarantee regarding the accuracy of the information, product features, availability, functionality, or suitability of its products for any particular purpose, nor does **onsemi** assume any liability arising out of the application or use of any product or circuit, and specifically disclaims any and all liability, including without limitation special, consequential or incidental damages. Buyer is responsible for its products and applications using **onsemi** products, including compliance with all laws, regulations and safety requirements or standards, regardless of any support or applications information provided by **onsemi**. "Typical" parameters which may be provided in **onsemi** data sheets and/or specifications can and do vary in different applications and actual performance may vary over time. All operating parameters, including "Typicals" must be validated for each customer application by customer's technical experts. **onsemi** does not convey any license under any of its intellectual property rights nor the rights of others. **onsemi** products are not designed, intended, or authorized for use as a critical component in life support systems or any FDA Class 3 medical devices or medical devices with a same or similar classification in a foreign jurisdiction or any devices intended for implantation in the human body. Should Buyer purchase or use **onsemi** products for any such unintended or unauthorized application, Buyer shall indemnify and hold **onsemi** and its officers, employees, subsidiaries, affiliates, and distributors harmless against all claims, costs, damages, and expenses, and reasonable attorney fees arising out of, directly or indirectly, any claim of personal injury or death associated with such unintended or unauthorized use, even if such claim alleges that **onsemi** was negligent regarding the design or manufacture of the part. **onsemi** is an Equal Opportunity/Affirmative Action Employer. This literature is subject to all applicable copyright laws and is not for resale in any manner. Other names and brands may be claimed as the property of others.

NCS6415

Bus-Controlled Video Matrix Switch

Description

The main function of the NCS6415 is to switch 8 video input sources to the 6 outputs.

Each output can be switched to only one of the inputs, whereas any single input may be connected to several outputs.

All switching possibilities are controlled through the I²C bus.

Features

- Cascadable with another NCS6415 (Internal Address can be changed by Pin 7 Voltage)
- 8 Inputs (CVBS, RGB, Chroma, ...)
- 6 Outputs with Low Impedance Driver
- Possibility of Chroma Signal for each Input by Switching off the Clamp with an External Resistor Bridge
- Bus Controlled
- 6.5 dB Gain between any Input and Output
- -45 dB Crosstalk at 5 MHz
- Compatible with TEA6415C
- Full ESD Protection
- These are Pb-Free Devices



ON Semiconductor[®]

<http://onsemi.com>

MARKING DIAGRAMS*

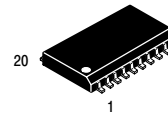

**SO-20 WB
DW SUFFIX
CASE 751D**

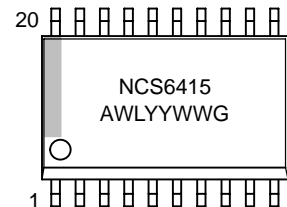

A = Assembly Location
 WL = Wafer Lot
 YY = Year
 WW = Work Week
 G = Pb-Free Package

*For additional marking information, refer to Application Note AND8002/D.

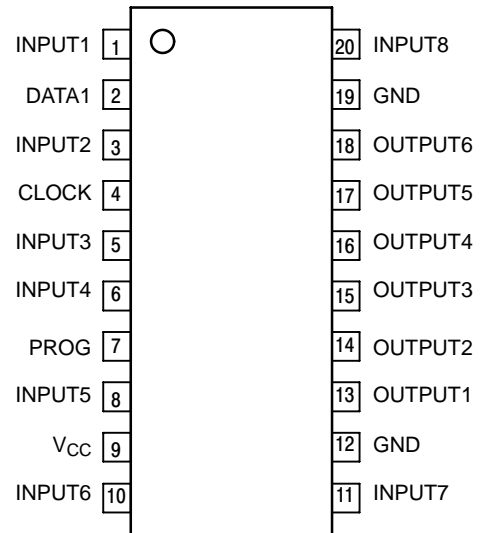

ORDERING INFORMATION

Device	Package	Shipping [†]
NCS6415DWG	SO-20 (Pb-Free)	38 Units / Rail
NCS6415DWR2G	SO-20 (Pb-Free)	1000 / Tape & Reel

[†]For information on tape and reel specifications, including part orientation and tape sizes, please refer to our Tape and Reel Packaging Specifications Brochure, BRD8011/D.

NCS6415

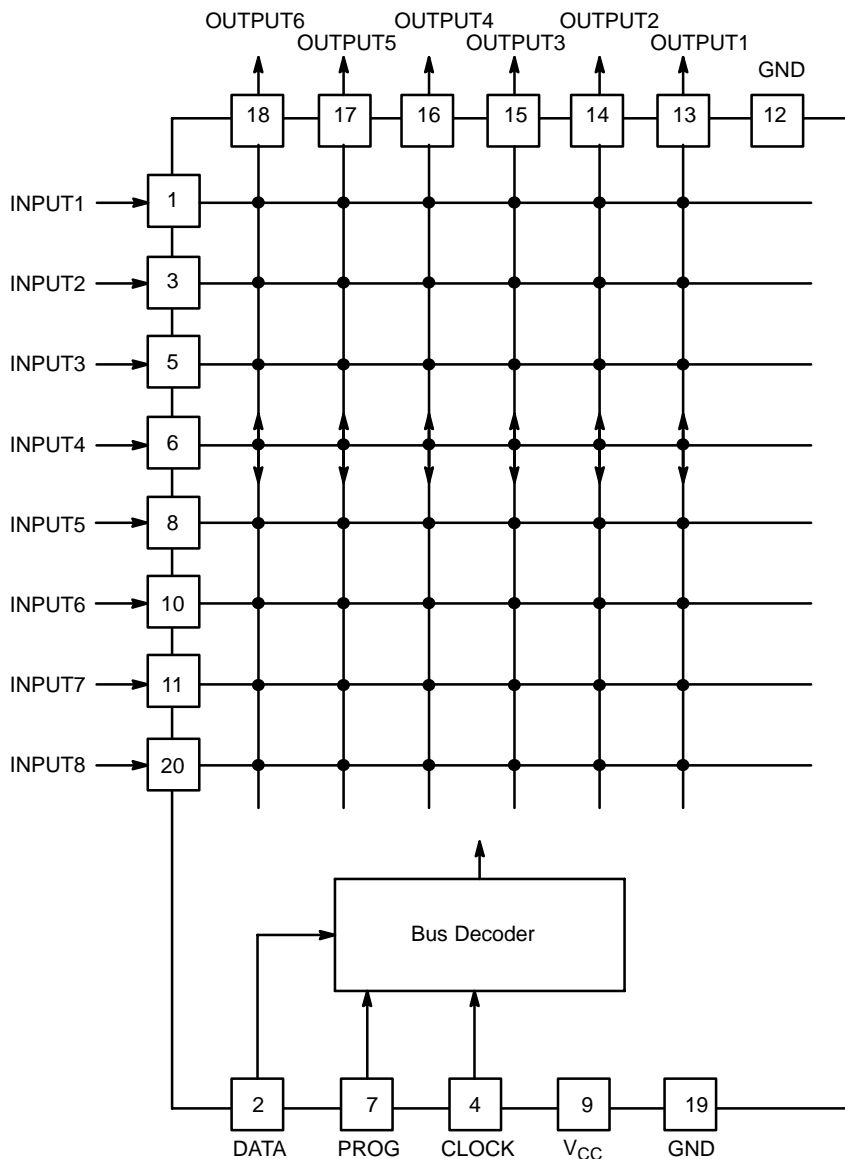

Figure 1. Block Diagram

The main function of the NCS6415 is to switch 8 video input sources to the 6 outputs.

Each output can be switched to only one of the inputs, whereas any single input may be connected to several outputs. The lowest level of each signal is aligned on each input (bottom of sync pulse for CVBS or Black Level for RGB signals).

The nominal gain between any input and output is 6 dB. For Chroma signals, the alignment is switched off by forcing, with an external 5' VDC resistor bridge on the input.

Each input can be used as a normal input or as a Chroma input (with external resistor bridge). All the switching possibilities are changed through the I²C bus.

The switches configuration is defined by words of 16 bits: one word of 16 bits for each output channel.

So, 6 words of 16 bits are necessary to determine the starting configuration upon power-on (power supply: 0 to 10 V). But a new configuration needs only the words of the changed output channels. Driving a 75 Ω load requires an external transistor.

NCS6415

Table 1. ATTRIBUTES

Characteristics		Value
ESD	Human Body Model	4 kV
	Machine Model	400 V
Moisture Sensitivity (Note 1)		Level 3
Flammability Rating	Oxygen Index: 28 to 34	UL 94 V-0 @ 0.125 in.

1. For additional information, see Application Note AND8003/D

Table 2. MAXIMUM RATINGS

Parameter	Symbol	Rating	Unit
Power Supply Voltage	V_{CC}	12	V
Operating Temperature Range	T_A	0 to +70	°C
Storage Temperature Range	T_{stg}	-60 to +150	°C
Thermal Resistance, Junction-to-Air	θ_{JA}	30 to 35	°C/W
	SO-20		

Stresses exceeding Maximum Ratings may damage the device. Maximum Ratings are stress ratings only. Functional operation above the Recommended Operating Conditions is not implied. Extended exposure to stresses above the Recommended Operating Conditions may affect device reliability.

Table 3. DC & AC Characteristics ($T_A = 25^\circ\text{C}$, $V_{CC} = 10\text{ V}$, $R_L = 10\text{ k}\Omega$, $C_L = 3\text{ pF}$)

Symbol	Parameter	Min	Typ	Max	Unit
V_{CC}	Supply Voltage	8	10	11	V
I_{CC}	Power Supply Current (No Load)	20	30	40	mA

INPUTS

	Signal Amplitude (CVBS signal) (Note 2)		1.5	2	V_{PP}
	Input Current (per output connected, $V_{IN} = 5\text{ V}_{DC}$)		1	3	μA
	DC Level	3.3	3.6	3.9	V
	DC Level Shift (0°C to 70°C)		5	100	mV
R_{IN}	Input Resistance		1		$M\Omega$
C_{IN}	Input Capacitance		2		pF

OUTPUTS

	Dynamic ($V_{IN} = 2.5\text{ V}_{PP}$)		5		V_{PP}
	Output Impedance (Note 2)		25	50	Ω
A_V	Gain (Note 2)	6	6.5	7	dB
BW	Bandwidth (Note 2) -1 dB Attenuation -3 dB Attenuation	7	15		MHz
			20		
	0.1 dB Gain Flatness (Note 2)	6			MHz
	Crosstalk		-48 -45		dB
			$f = 3.58\text{ MHz}$ $f = 5\text{ MHz}$		
	DC Level	2.4	2.75	3.1	V

I²C BUS INPUT: DATA, CLOCK AND PROG

	Threshold Voltage	1.5	2	3	V
--	-------------------	-----	---	---	---

2. Guaranteed by design and/or characterization.

NCS6415

Table 4. I²C Bus Characteristics

Symbol	Parameter	Test Conditions	Min	Max	Unit
SCL					
V _{IL}	Low Level Input Voltage		-0.3	+1.5	V
V _{IH}	High Level Input Voltage		3.0	V _{CC} +0.5	V
I _{LI}	Input Leakage Current	V _I = 0 to V _{CC}	-10	+10	μA
f _{SCL}	Clock Frequency (Note 3)		0	100	kHz
t _R	Input Rise Time (Note 3)	1.5 V to 3 V		1000	ns
t _F	Input Fall Time (Note 3)	3 V to 1.5 V		300	ns
C _I	Input Capacitance (Note 3)			10	pF
SDA					
V _{IL}	Low Level Input Voltage		-0.3	+1.5	V
V _{IH}	High Level Input Voltage		3.0	V _{CC} +0.5	V
I _{LI}	Input Leakage Current	V _I = 0 to V _{CC}	-10	+10	μA
C _I	Input Capacitance (Note 3)			10	pF
t _R	Input Rise Time (Note 3)	1.5 V to 3 V		1000	ns
t _F	Input Fall Time (Note 3)	3 V to 1.5 V		300	ns
V _{OL}	Low Level Output Voltage	I _{OL} = 3 mA		0.4	V
t _F	Output Fall Time (Note 3)	3V to 1.5 V		250	ns
C _L	Load Capacitance			400	pF
TIMING					
t _{LOW}	Clock Low Period (Note 4)		4.7		μs
t _{HIGH}	Clock High Period (Note 4)		4.0		μs
t _{SU,DAT}	Data Setup Time (Note 4)		250		ns
t _{HD,DAT}	Data Hold Time (Note 4)		0	340	ns
t _{SU,STO}	Setup Time from Clock High to Stop (Note 4)		4.0		μs
t _{BUF}	Start Setup Time following a Stop (Note 4)		4.7		μs
t _{HD,STA}	Start Hold Time (Note 4)		4.0		μs
t _{SU,STA}	Start Setup Time following Clock Low to High Transition (Note 4)		4.7		μs

3. Guaranteed by design and/or characterization.

4. Functionality guaranteed by design and/or characterization.

NCS6415

I²C Bus Selections

The I²C chip address is defined by the first byte. The second byte defines the input/output configuration.

Table 5. CHIP ADDRESS BYTE (1ST BYTE OF TRANSMISSION)

HEX	BINARY	Comment
86	1000 0110	When PROG pin is connected to Ground
06	0000 0110	When PROG pin is connected to V _{CC}

Input/Output Selection Byte (2nd byte of transmission)

Table 6. I²C BUS OUTPUT SELECTIONS

Output Address (MSB)	Input Address (LSB)	Selected Output	
00000	XXX	Pin 18	Output is selected by the 5 MSBs.
00100	XXX	Pin 14	
00010	XXX	Pin 16	
00110	-	Not Used	
00001	XXX	Pin 17	
00101	XXX	Pin 13	
00011	XXX	Pin 15	
00111	-	Not Used	

Table 7. I²C BUS INPUT SELECTIONS

Output Address (MSB)	Input Address (LSB)	Selected Input	
00XXX	000	Pin 5	Input is selected by the 3 LSBs.
00XXX	100	Pin 8	
00XXX	010	Pin 3	
00XXX	110	Pin 20	
00XXX	001	Pin 6	
00XXX	101	Pin 10	
00XXX	011	Pin 1	
00XXX	111	Pin 11	

Example: 0010 0101 (Binary) or 25 (Hex) connects Pin 10 (input) to Pin 14 (output)

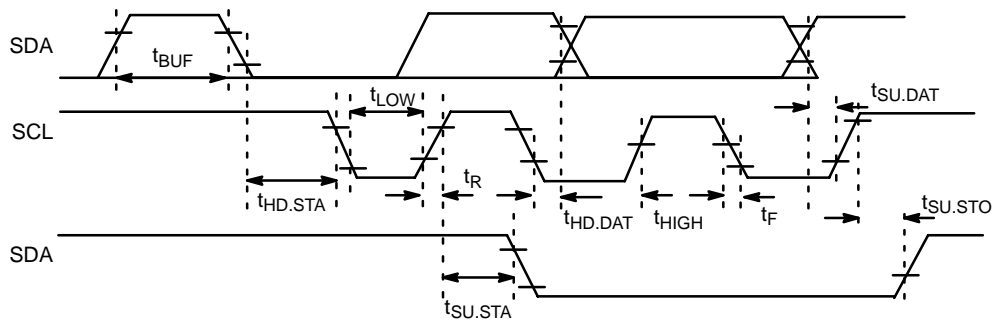

Figure 2. I²C Timing Diagram

NCS6415

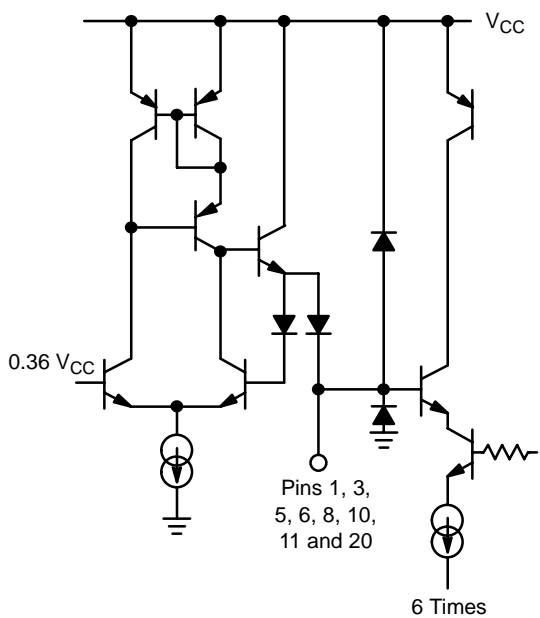

Figure 3. Input Configuration

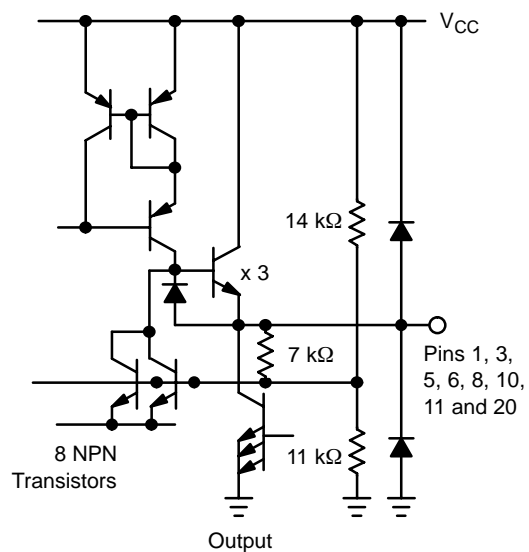

Figure 4. Output Configuration

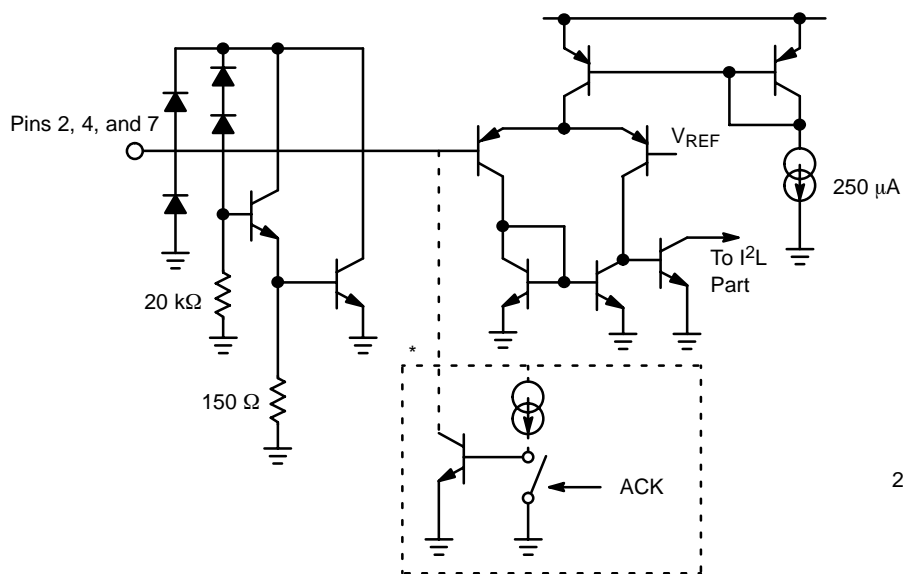

Figure 5. Bus I/O Configuration

*For Pin 2 (Data Only)

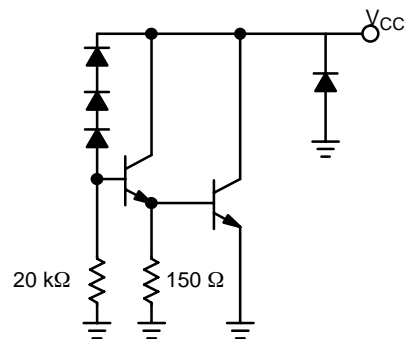

Figure 6. V_{CC} Pin Configuration

NCS6415

USING A SECOND NCS6415

The programming input pin (PROG) allows two NCS6415 circuits to operate in parallel and to select them independently through the I²C bus by modifying the address

byte. Consequently, the switching capabilities are doubled, or IC1 and IC2 can be cascaded (see Figure 7).

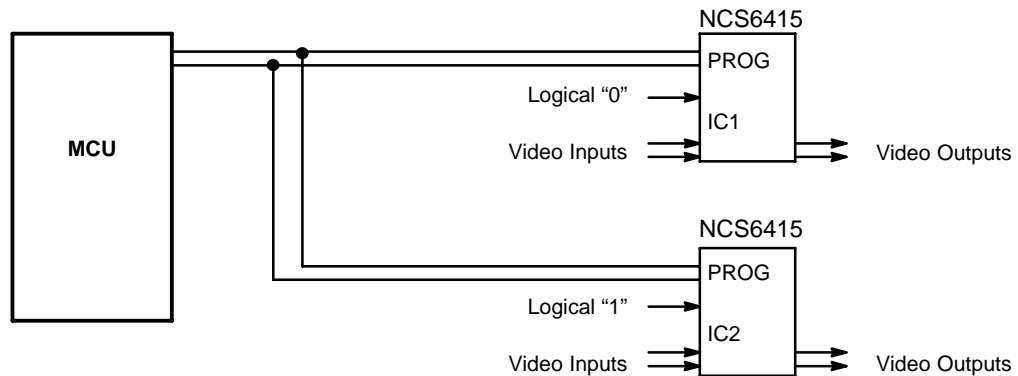

Figure 7. Cascaded NCS6415

TYPICAL APPLICATION DIAGRAM

NCS6415 is suited for single supply system, running on a single +10 V supply. The high quality of the output stage and excellent linearity provides video signal comparable to

broadcast studio quality signals. The layout is not as critical to the design and it can be easily realized on a single sided board.

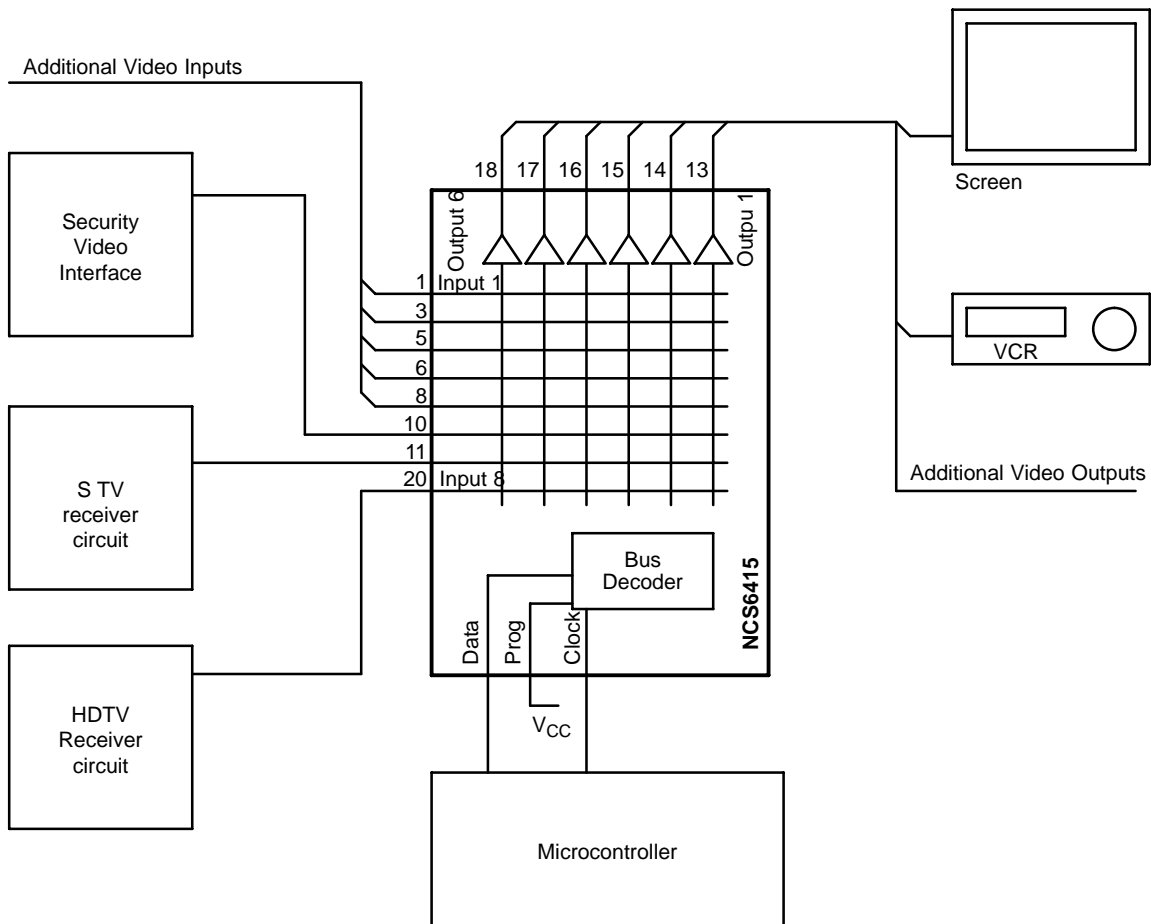

Figure 8. Typical Application Diagram

NCS6415

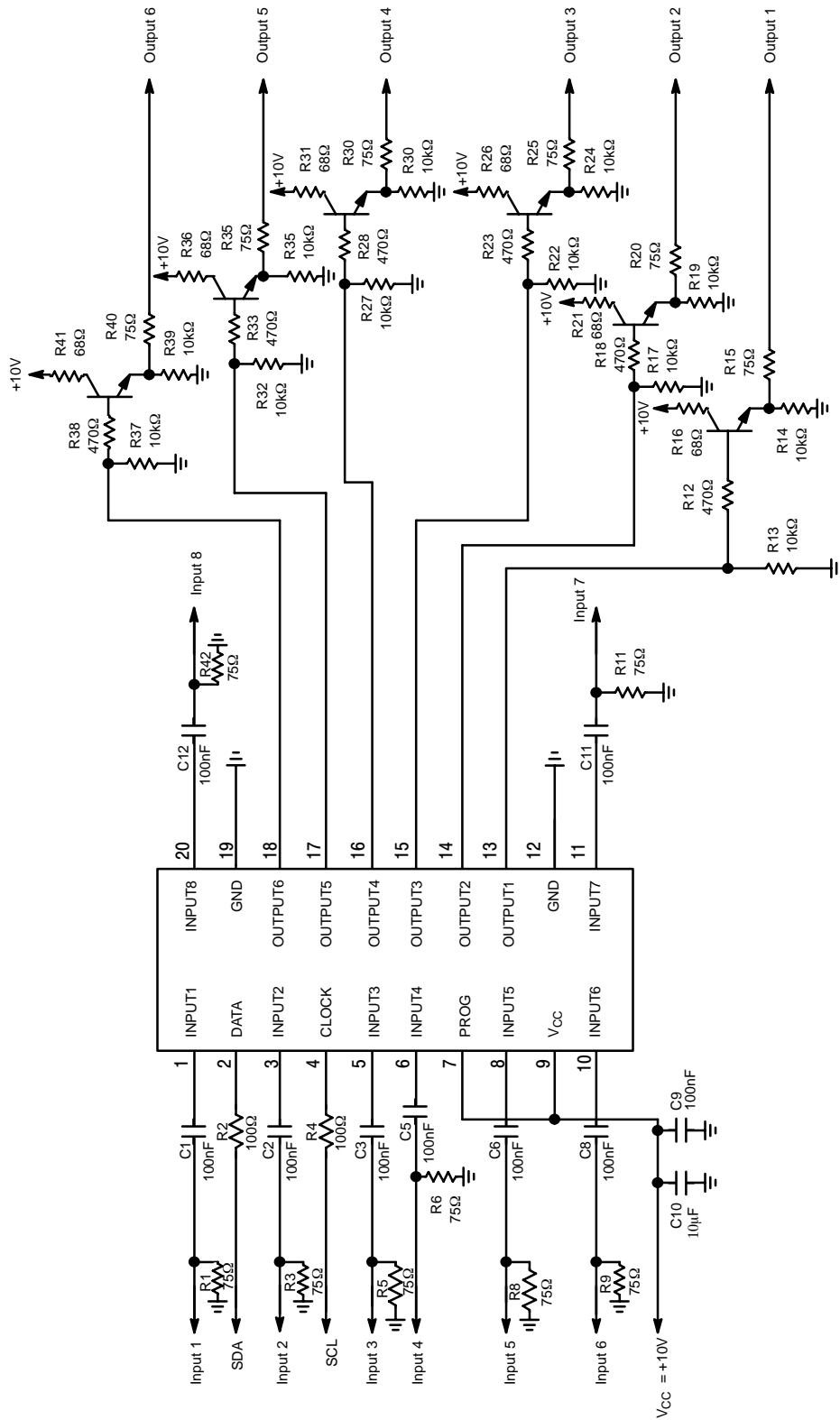
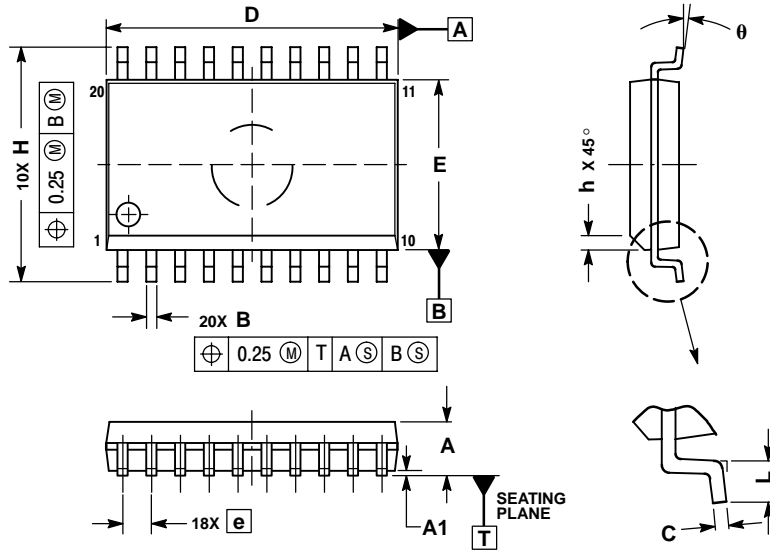

Figure 9. Typical Application Circuit

NCS6415

PACKAGE DIMENSIONS

SO-20 WB
CASE 751D-05
ISSUE G



NOTES:

1. DIMENSIONS ARE IN MILLIMETERS.
2. INTERPRET DIMENSIONS AND TOLERANCES PER ASME Y14.5M, 1994.
3. DIMENSIONS D AND E DO NOT INCLUDE MOLD PROTRUSION.
4. MAXIMUM MOLD PROTRUSION 0.15 PER SIDE.
5. DIMENSION B DOES NOT INCLUDE DAMBAR PROTRUSION. ALLOWABLE PROTRUSION SHALL BE 0.13 TOTAL IN EXCESS OF B DIMENSION AT MAXIMUM MATERIAL CONDITION.

DIM	MILLIMETERS	
	MIN	MAX
A	2.35	2.65
A1	0.10	0.25
B	0.35	0.49
C	0.23	0.32
D	12.65	12.95
E	7.40	7.60
e	1.27 BSC	
H	10.05	10.55
h	0.25	0.75
L	0.50	0.90
θ	0°	7°

ON Semiconductor and are registered trademarks of Semiconductor Components Industries, LLC (SCILLC). SCILLC reserves the right to make changes without further notice to any products herein. SCILLC makes no warranty, representation or guarantee regarding the suitability of its products for any particular purpose, nor does SCILLC assume any liability arising out of the application or use of any product or circuit, and specifically disclaims any and all liability, including without limitation special, consequential or incidental damages. "Typical" parameters which may be provided in SCILLC data sheets and/or specifications can and do vary in different applications and actual performance may vary over time. All operating parameters, including "Typicals" must be validated for each customer application by customer's technical experts. SCILLC does not convey any license under its patent rights nor the rights of others. SCILLC products are not designed, intended, or authorized for use as components in systems intended for surgical implant into the body, or other applications intended to support or sustain life, or for any other application in which the failure of the SCILLC product could create a situation where personal injury or death may occur. Should Buyer purchase or use SCILLC products for any such unintended or unauthorized application, Buyer shall indemnify and hold SCILLC and its officers, employees, subsidiaries, affiliates, and distributors harmless against all claims, costs, damages, and expenses, and reasonable attorney fees arising out of, directly or indirectly, any claim of personal injury or death associated with such unintended or unauthorized use, even if such claim alleges that SCILLC was negligent regarding the design or manufacture of the part. SCILLC is an Equal Opportunity/Affirmative Action Employer. This literature is subject to all applicable copyright laws and is not for resale in any manner.

PUBLICATION ORDERING INFORMATION

LITERATURE FULFILLMENT:
Literature Distribution Center for ON Semiconductor
P.O. Box 5163, Denver, Colorado 80217 USA
Phone: 303-675-2175 or 800-344-3860 Toll Free USA/Canada
Fax: 303-675-2176 or 800-344-3867 Toll Free USA/Canada
Email: orderlit@onsemi.com

N. American Technical Support: 800-282-9855 Toll Free USA/Canada
Europe, Middle East and Africa Technical Support:
Phone: 421 33 790 2910
Japan Customer Focus Center
Phone: 81-3-5773-3850

ON Semiconductor Website: www.onsemi.com
Order Literature: <http://www.onsemi.com/orderlit>
For additional information, please contact your local Sales Representative

Looking for pricing, stock, or lifecycle information?

Click below to explore more details on WIN SOURCE:

 [View NCS6415DWR2G on WIN SOURCE](#)

 [ON Semiconductor](#) Information

Optimize Your Supply Chain with WIN SOURCE Solutions

-  Global Sourcing Solution
-  Obsolete Management
-  Cost Control Management
-  Shortage Management
-  Alternative Solution
-  Excess Inventory Management