



**THE DATASHEET OF
AP3608EFNTR-G1**



**EIGHT-CHANNEL CONSTANT CURRENT SINK WITH CURRENT MATCH AP3608E****General Description**

The AP3608E is an eight-channel constant current sink with current match used for LED driver. It uses an external resistor to set the current for eight LED strings with an accuracy of $\pm 1.5\%$. The full scale LED current can be adjusted from 10mA to 100mA for each channel. The LED light can be adjusted by PWM dimming function.

The device can keep working when LED opens without damage. It features under voltage lockout protection and over temperature protection.

The AP3608E has four interface terminals (FB, SDB, FBX and SDBX pins). The first two terminals allow the device to work with a DC/DC converter to drive LED arrays for good performance. And the other two enable the device to be connected in parallel.

The AP3608E is available in QFN-4x4-24, TSSOP-20(EDP) and SOIC-20 packages.

Features

- Input Voltage Range: 4.2V to 5.5V
- Typical Output Current: 480mA (60mA/1V per Channel)
- Maximum Output Current: 800mA (100mA/1.5V per Channel)
- Current Match Accuracy: $\pm 1.5\%$
- PWM Dimming Control
- Open LED Self-check and Protection
- Under Voltage Lockout Protection
- Over Temperature Protection
- FBX and SDBX Pins Enable Parallel Application

Applications

- Notebook
- LCD Display Modules
- LCD Monitor
- LCD TV

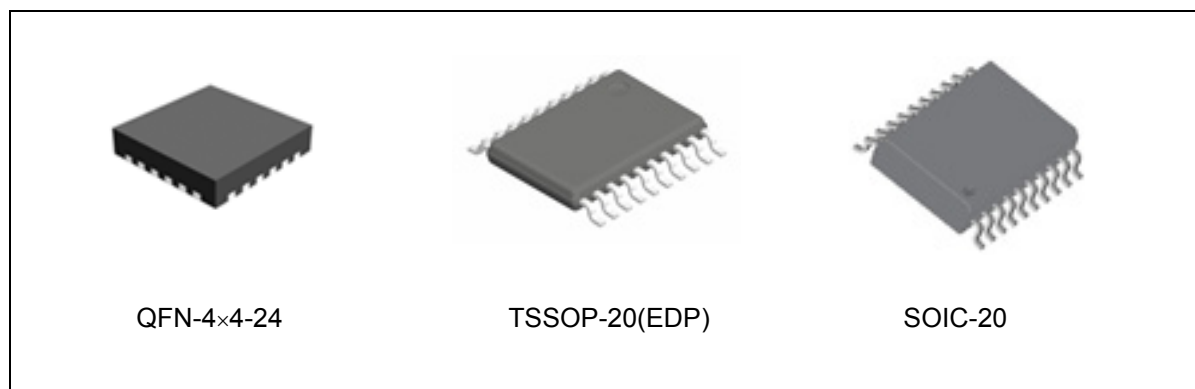

Figure 1. Package Types of AP3608E

EIGHT-CHANNEL CONSTANT CURRENT SINK WITH CURRENT MATCH AP3608E

Pin Configuration

FN Package
(QFN-4×4-24)

Pin 1 Dot by Marking

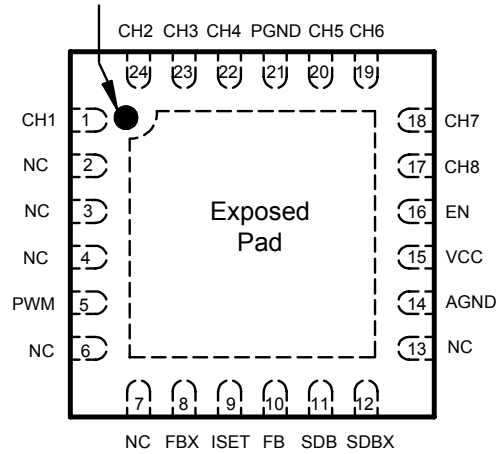

G/M Package
(TSSOP-20(EDP)/SOIC-20)

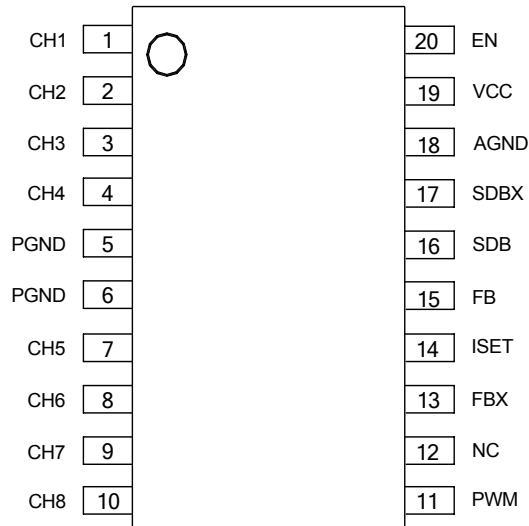

Note: AGND must be quiet and directly connected to total C_{IN}

Figure 2. Pin Configuration of AP3608E (Top View)

**EIGHT-CHANNEL CONSTANT CURRENT SINK WITH CURRENT MATCH AP3608E****Pin Description**

Pin Number		Pin Name	Function
QFN-4×4-24	TSSOP-20(EDP)/ SOIC-20		
1, 24, 23, 22, 20, 19, 18, 17	1, 2, 3, 4, 7, 8, 9, 10	CH1 to CH8	White LED cathode connection pin. These pins should be connected to GND if not used
2, 3, 4, 6, 7, 13	12	NC	No connection
5	11	PWM	PWM dimming control pin. Adding a PWM signal to this pin to control LED dimming (see Figure 10 for detail dimming control mode). If not used, connect it to the high level
8	13	FBX	This pin is an interface terminal. Connecting it with FB pin can achieve parallel application. If not used, leave it unconnected
9	14	ISET	LED current set pin. An external resistor is connected to this pin to set each channel current according to $I_{CHANNEL} = 1.194 * 400 / R_{ISET}$
10	15	FB	Feedback pin. This pin is an interface terminal, which samples the voltage of each channel, and outputs the lowest voltage of the string to DC/DC converter
11	16	SDB	This pin is an interface terminal. SDB pin outputs low logic to DC/DC converter under the conditions such as AP3608E receives shutdown signal from EN pin or all channels are inactive. When AP3608E is on PWM dimming mode, the signal in SDB pin is synchronous with PWM signal
12	17	SDBX	This pin is an interface terminal. Connecting it with SDB pin can achieve parallel application. If not used, connect it to GND
14	18	AGND	Ground pin. It would be useful when connected with PGND and exposed pad
15	19	VCC	Input voltage pin
16	20	EN	Enable pin. Logic high enables the IC and logic low disables the IC
21	5, 6	PGND	Ground pin. It would be useful when connected with AGND and exposed pad
		EP	Exposed pad. It would be useful when connected with AGND and PGND

EIGHT-CHANNEL CONSTANT CURRENT SINK WITH CURRENT MATCH AP3608E

Functional Block Diagram

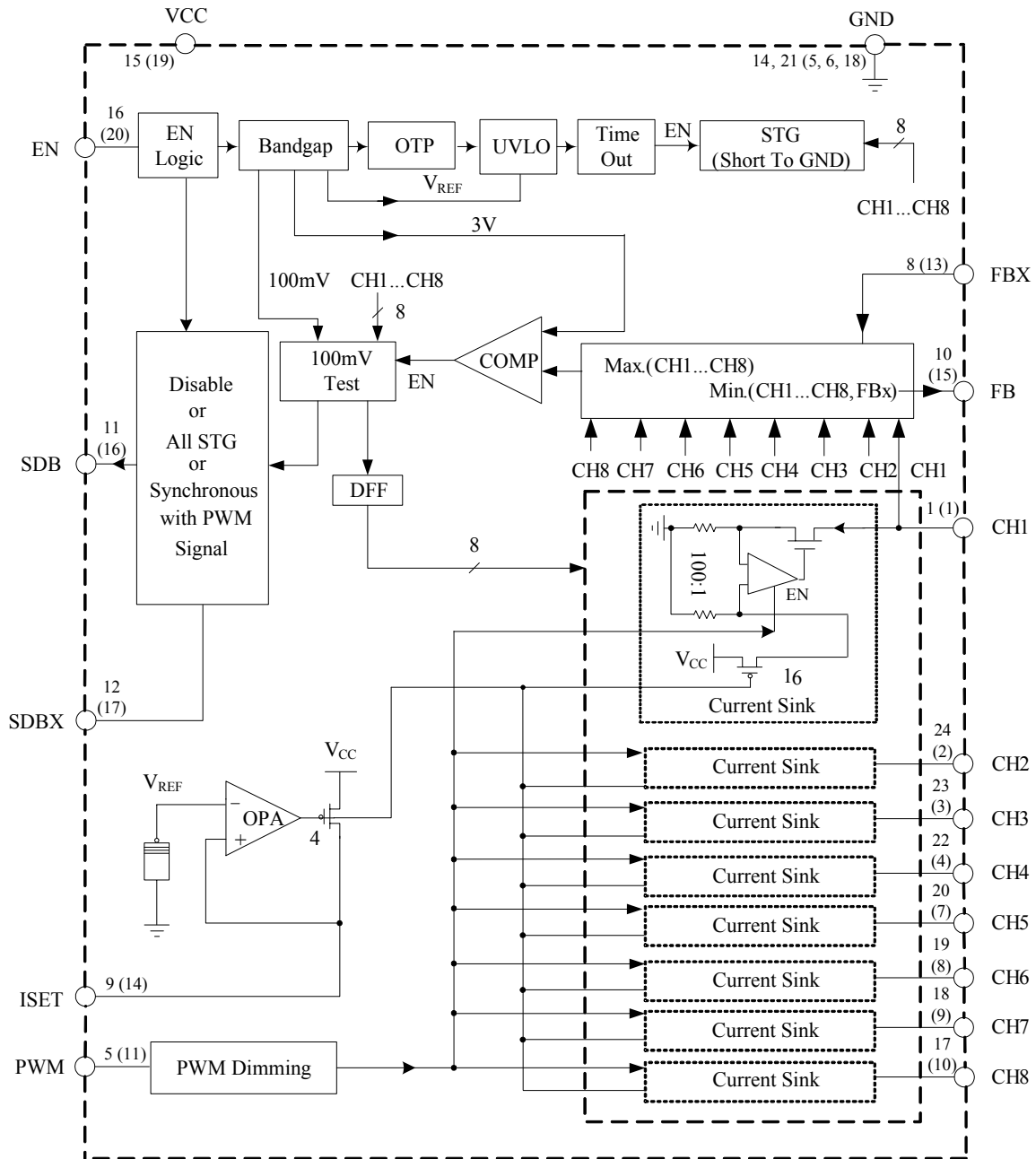

A (B)
 A for QFN-4x4-24
 B for TSSOP-20(EDP)/SOIC-20

Figure 3. Functional Block Diagram of AP3608E



EIGHT-CHANNEL CONSTANT CURRENT SINK WITH CURRENT MATCH AP3608E

Ordering Information

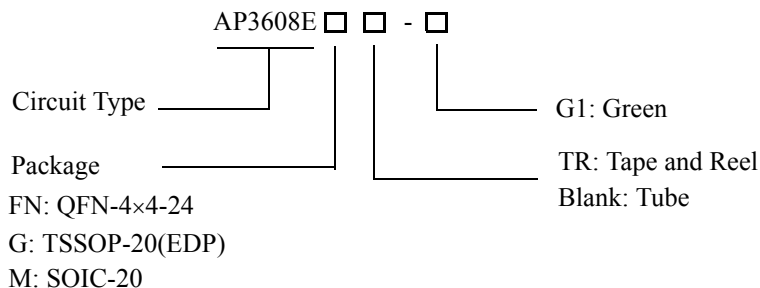

Package	Temperature Range	Part Number	Marking ID	Packing Type
QFN-4×4-24	-40 to 85°C	AP3608EFNTR-G1	B3B	Tape & Reel
TSSOP-20(EDP)		AP3608EGTR-G1	AP3608EG-G1	Tape & Reel
SOIC-20		AP3608EM-G1	AP3608EM-G1	Tube
		AP3608EMTR-G1	AP3608EM-G1	Tape & Reel

BCD Semiconductor's Pb-free products, as designated with "G1" suffix in the part number, are RoHS compliant and green.

Absolute Maximum Ratings (Note 1)

Parameter	Symbol	Value	Unit	
Input Voltage	V_{CC}	-0.3 to 6	V	
ISET Pin Voltage	V_{ISET}	-0.3 to 6	V	
EN Pin Voltage	V_{EN}	-0.3 to 6	V	
Feedback Pin Voltage	V_{FB}	-0.3 to 6	V	
SDB Pin Voltage	V_{SDB}	-0.3 to 6	V	
PWM Pin Voltage	V_{PWM}	-0.3 to 6	V	
Voltage per Channel (Note 3)	V_{CHX}	-0.3 to 40	V	
Thermal Resistance (Junction to Ambient, No Heat Sink)	θ_{JA}	QFN-4×4-24	60	°C/W
		TSSOP-20(EDP)	35 (Note 2)	
		SOIC-20	87	
Operating Junction Temperature	T_J	150	°C	
Storage Temperature Range	T_{STG}	-65 to 150	°C	
Lead Temperature (Soldering, 10sec)	T_{LEAD}	260	°C	
ESD (Machine Model)		200	V	
ESD (Human Body Model)		6000	V	

Note 1: Stresses greater than those listed under "Absolute Maximum Ratings" may cause permanent damage to the device. These are stress ratings only, and functional operation of the device at these or any other conditions beyond those indicated under "Recommended Operating Conditions" is not implied. Exposure to "Absolute Maximum Ratings" for extended periods may affect device reliability.

Note 2: The chip is soldered to 60mm² (4mm×15mm) copper (top side solder mask) of 1oz. on PCB with 8×0.5mm vias.

Note 3: Breakdown voltage.



EIGHT-CHANNEL CONSTANT CURRENT SINK WITH CURRENT MATCH AP3608E

Recommended Operating Conditions

Parameter	Symbol	Min	Max	Unit
Input Voltage	V_{CC}	4.2	5.5	V
Recommended PWM Dimming Frequency	f_{PWM}	0.1	25	kHz
Full Scale Setting Current per Channel	$V_{CHX} \geq 0.5V$	10	25	mA
	$V_{CHX} \geq 1V$	10	65	
	$V_{CHX} \geq 1.5V$	10	110	
Operating Temperature Range	T_A	-40	85	°C

Electrical Characteristics

Limits in standard typeface are guaranteed for $V_{IN}=V_{EN}=5V$, $R_{ISET}=8k\Omega$, $T_A=25^\circ C$, unless otherwise specified.

Parameter	Symbol	Conditions	Min	Typ	Max	Unit
Input Section						
Input Voltage	V_{IN}		4.2		5.5	V
Quiescent Current	I_Q	No load		0.5	1	mA
Shutdown Quiescent Current	I_{SDB}	$V_{EN}=0V$		0.1	1	μA
Under Voltage Lockout Threshold	V_{UVLO}	Falling Edge	3.6	3.8	4.0	V
Under Voltage Lockout Hysteresis	V_{HUVLO}			200		mV
Current Sink Section						
ISET Reference Voltage	V_{ISET}		1.170	1.194	1.218	V
Current Multiplication Ratio	K	I_{CHX}/I_{SET}	370	400	430	
Maximum Output Current per Channel	I_{CHX_MAX}	$V_{CHX}=0.5V$	23	45		mA
		$V_{CHX}=1V$	65	70		
		$V_{CHX}=1.5V$	110	120		
Current Matching between Any Two Channels	$I_{CH-MATCH}$	$I_{CHX}=60mA$ $V_{CHX}=1V$	-1.5		1.5	%
Current Sink Saturation Voltage per Channel	V_{CHX_SAT}	$I_{CHX}=20mA$			0.45	V
		$I_{CHX}=60mA$			0.8	
		$I_{CHX}=100mA$			1.2	
Output Current Line Regulation		$V_{CC}=4.2V$ to $5.5V$			2	%/V
Output Current Load Regulation		$V_{CHX}=0.5V$ to $2.8V$			4	%



EIGHT-CHANNEL CONSTANT CURRENT SINK WITH CURRENT MATCH AP3608E

Electrical Characteristics (Continued)

Limits in standard typeface are guaranteed for $V_{IN}=V_{EN}=5V$, $R_{ISET}=8k\Omega$, $T_A=25^\circ C$, unless otherwise specified.

Parameter	Symbol	Conditions	Min	Typ	Max	Unit
Enable Section						
EN Pin High Level Threshold Voltage	V_{IH_EN}		1.8			V
EN Pin Low Level Threshold Voltage	V_{IL_EN}				0.8	V
PWM Dimming Section						
PWM High Level Threshold Voltage	V_{IH_PWM}		1.8			V
PWM Low Level Threshold Voltage	V_{IL_PWM}				0.8	V
Interface Section						
SDB High Level Output Voltage	V_{OH}		2.4			V
SDB Low Level Output Voltage	V_{OL}				0.4	V
Feedback Output Current	I_{FB}		5	15		μA
Total Device						
Self-check Voltage @ Open LED	V_{CHECK}			3.0		V
Thermal Shutdown Temperature	T_{OTSD}			160		$^\circ C$
Thermal Shutdown Hysteresis	T_{HYS}			20		$^\circ C$

Typical Performance Characteristics

$V_{IN}=V_{EN}=5V$, $R_{ISET}=8k\Omega$, $T_A=25^\circ C$, unless otherwise specified.

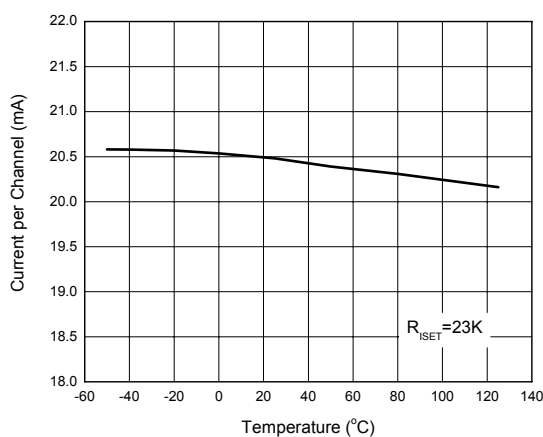

Figure 4. Current per Channel vs. Temperature

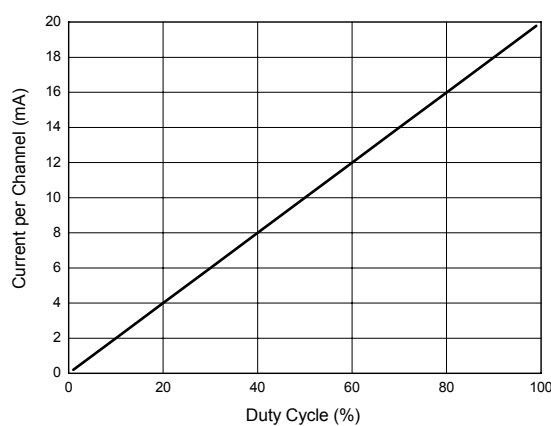

Figure 5. Current per Channel vs. Duty Cycle



EIGHT-CHANNEL CONSTANT CURRENT SINK WITH CURRENT MATCH AP3608E

Typical Performance Characteristics (Continued)

$V_{IN}=V_{EN}=5V$, $R_{ISET}=8k\Omega$, $T_A=25^\circ C$, unless otherwise specified.

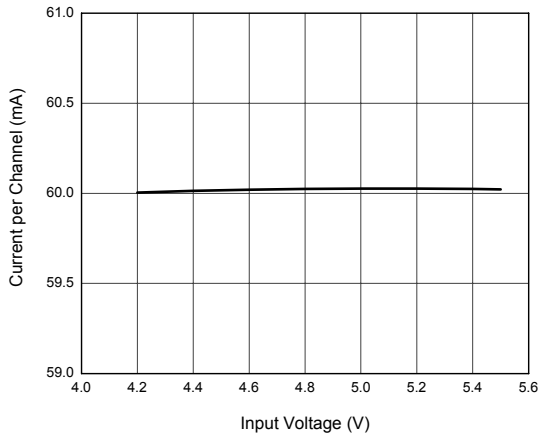

Figure 6. Current per Channel vs. Input Voltage

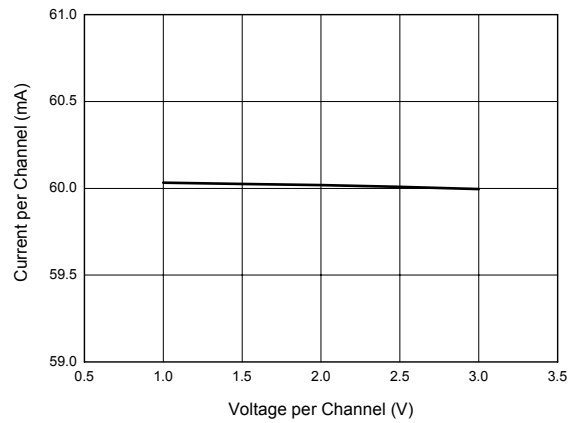

Figure 7. Current per Channel vs. Voltage per Channel

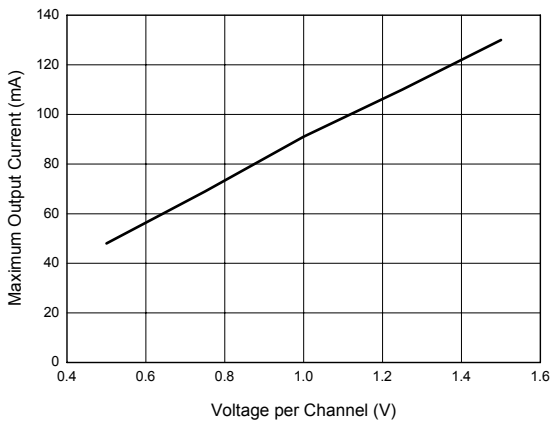

Figure 8. Maximum Output Current vs. Voltage per Channel

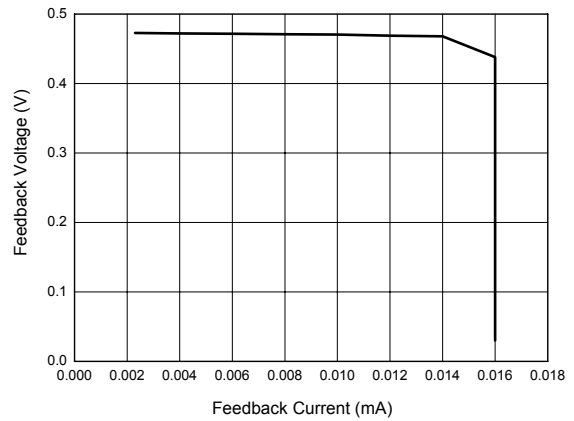

Figure 9. Feedback Voltage vs. Feedback Current

EIGHT-CHANNEL CONSTANT CURRENT SINK WITH CURRENT MATCH AP3608E

Function Description

The AP3608E is designed for LED display application which contains eight well-matched current sinks to provide constant current through LED. The full scale LED current can be adjusted from 10mA to 100mA per channel with an external resistor. If there is some channel unused, the channel pin should be connected to ground. The LED bright dimming can be achieved through PWM dimming.

The AP3608E can work with a DC/DC converter to drive LED arrays for good performance. The device can keep working when LED opens without damage, and it features under voltage lockout protection and over temperature protection. The detailed information will be discussed in open LED self-check and protection section.

1. LED Current Setting

The maximum LED current can be set up to 100mA per channel by ISET pin. When the LED current is greater than 100mA, two or more channels can be paralleled to achieve larger drive current. To set the reference current ISET, connect a resistor R_{ISET} between this pin and ground. The value of R_{ISET} can be calculated by the following formula:

$$I_{SET} = 1.194V / R_{ISET}$$

This reference current is multiplied internally with a gain (K) of 400, and then mirrored on all enabled channels. This sets the maximum LED current, referred to as 100% current (I_{CHX_MAX}). The value can be calculated by the following formula:

$$I_{CHX_MAX} = K \cdot I_{SET}$$

The LED current can be reduced from 100% by PWM dimming control.

2. PWM Dimming Mode

The LED current can be adjusted by applying the PWM signal to PWM pin. On this mode, all enabled channels are adjusted at the same time and the brightness can be adjusted from 1%*I_{CHX_MAX} to 100%*I_{CHX_MAX}(@f_{Dimming}=2kHz). During the "high level" time of the PWM signal, the LED turns on and the 100% current flows through LED. During the "low level" time of the PWM signal, the LED turns off and almost no current flows through LED. So the average current through LED is changed and the brightness is adjusted. The external PWM signal frequency applied to PWM pin can be allowed to 100Hz or higher.

An example for PWM dimming is shown in Figure 10. All 8 channels are set to the maximum current I_{CHX_MAX} at the beginning. When a 50% duty cycle PWM signal is applied to PWM pin, average current valued 50%* I_{CHX_MAX} flows through the 8 channels. When an 80% duty cycle PWM signal is applied to PWM pin, average current valued 80%*I_{CHX_MAX} flows through the 8 channels.

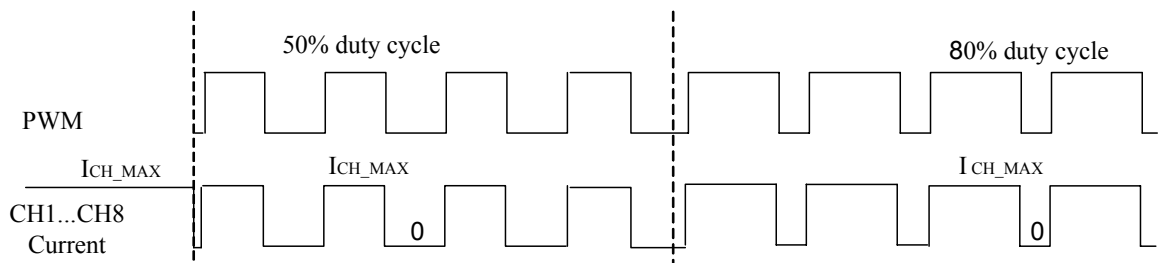

Figure 10. PWM Dimming Example of AP3608E

**EIGHT-CHANNEL CONSTANT CURRENT SINK WITH CURRENT MATCH AP3608E****Function Description (Continued)****3. Open LED Self-Check and Protection**

The AP3608E can work with a DC/DC converter to achieve good performance, such as self-check and protection against open LED. The SDB pin and FB pin are the interface terminals for working with the DC/DC converter. FB pin samples voltage of each channel, and outputs the lowest voltage of all strings to DC/DC converter. When AP3608E gets shutdown signal from EN pin or all channels are inactive, SDB pin outputs low logic to DC/DC converter. When AP3608E is on PWM dimming mode, the SDB pin outputs the signal which is synchronous with PWM signal to DC/DC converter. Figure 11 is the typical circuit of AP3608E applied with a boost converter AP3039.

If any enabled LED string opens, voltage on the corresponding CHX pin goes to zero and the FB pin outputs the zero voltage to boost converter. So the boost converter operates in open loop and the voltage

on remaining CHX pin goes higher. Once the voltage on remaining CHX pin reaches the self-check voltage 3V, the AP3608E begins looking up the open string. After finding the open channel, AP3608E removes the corresponding CHX pin from boost control loop, then the boost circuit is controlled in the normal manner. Once the circuit returns normal operation, the voltage on the CHX pin is regulated to the normal level. It is necessary to pay attention that the open strings are removed from boost regulation, but not disabled. If the open LED string is reconnected, it will sink current up to the programmed current level.

4. Parallel Operation Mode

The AP3608E can be paralleled to drive more strings of LED. Connecting an AP3608E SDB pin and FB pin with another AP3608E SDBX pin and FBX pin can achieve parallel application. More details please refer to Figure 11.



EIGHT-CHANNEL CONSTANT CURRENT SINK WITH CURRENT MATCH AP3608E

Typical Application

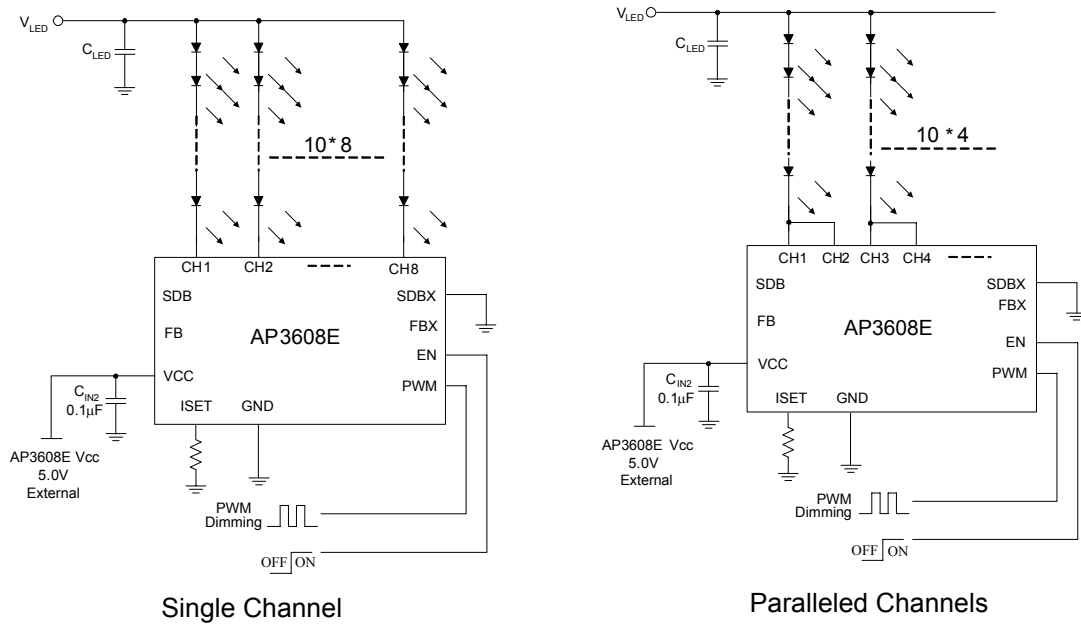

Single Chip Application

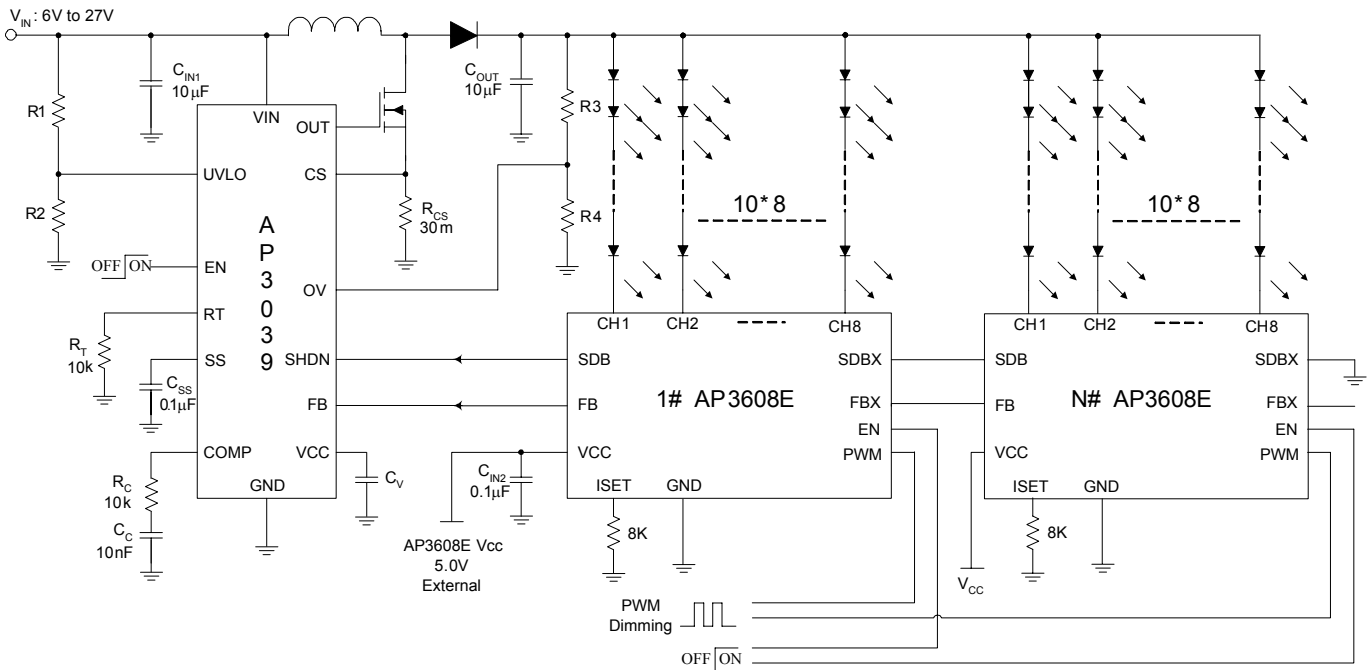

Multi Chips Application

Figure 11. Typical Applications of AP3608E



EIGHT-CHANNEL CONSTANT CURRENT SINK WITH CURRENT MATCH AP3608E

Mechanical Dimensions

QFN-4x4-24

Unit: mm(inch)

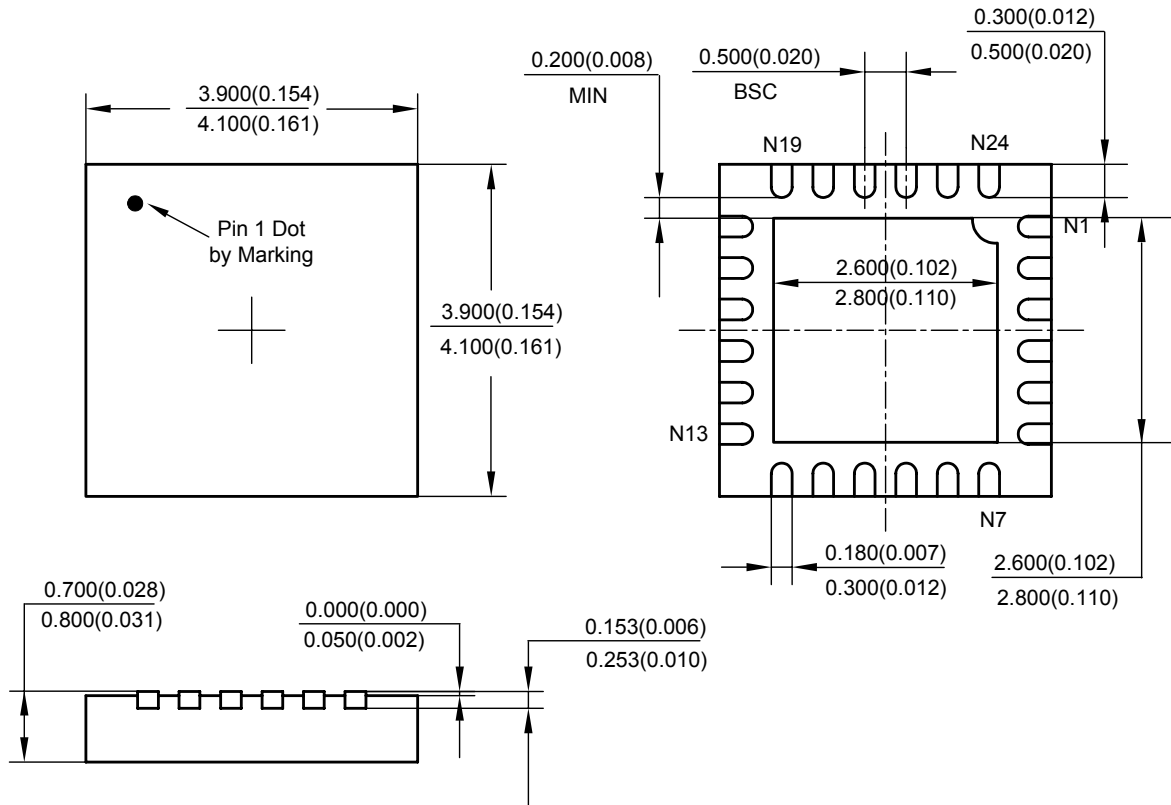



EIGHT-CHANNEL CONSTANT CURRENT SINK WITH CURRENT MATCH AP3608E

Mechanical Dimensions (Continued)

TSSOP-20(EDP)

Unit: mm(inch)

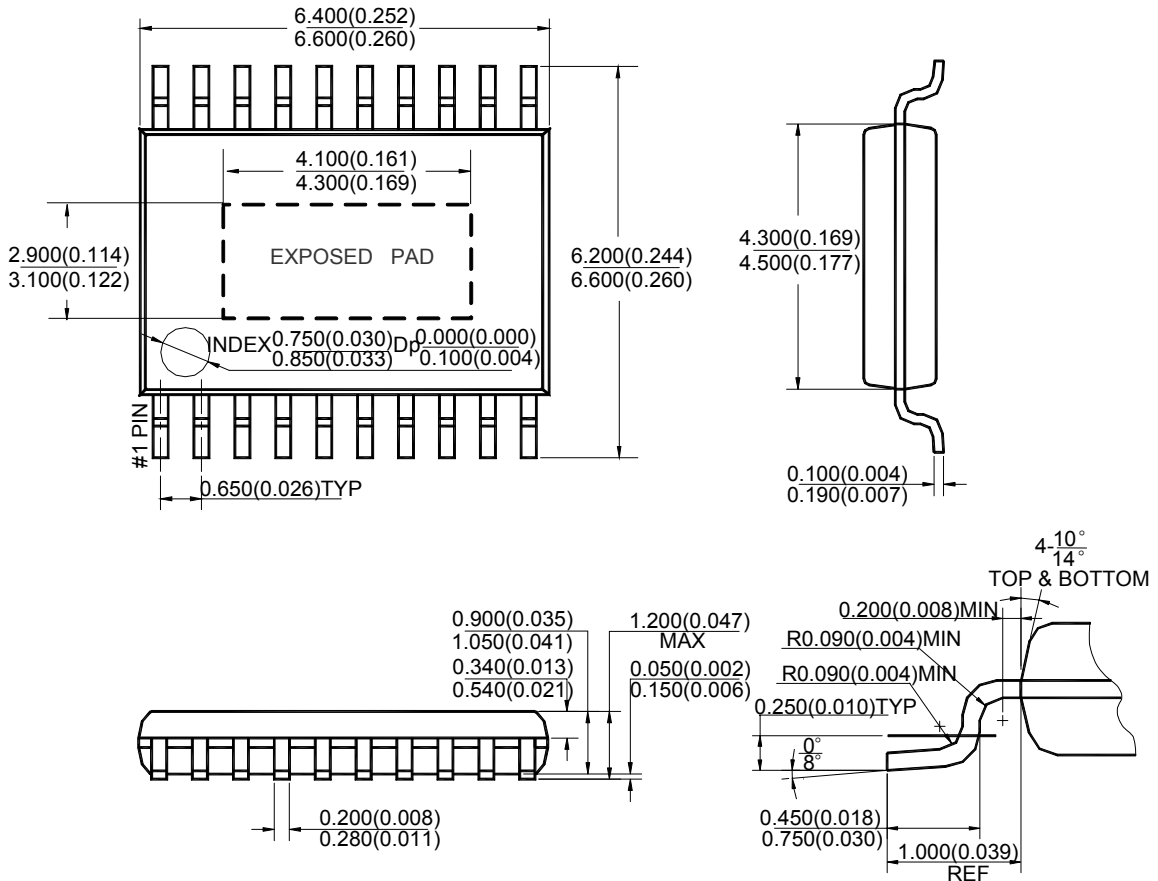

Note: Eject hole, oriented hole and mold mark is optional.



EIGHT-CHANNEL CONSTANT CURRENT SINK WITH CURRENT MATCH AP3608E

Mechanical Dimensions (Continued)

SOIC-20

Unit: mm(inch)

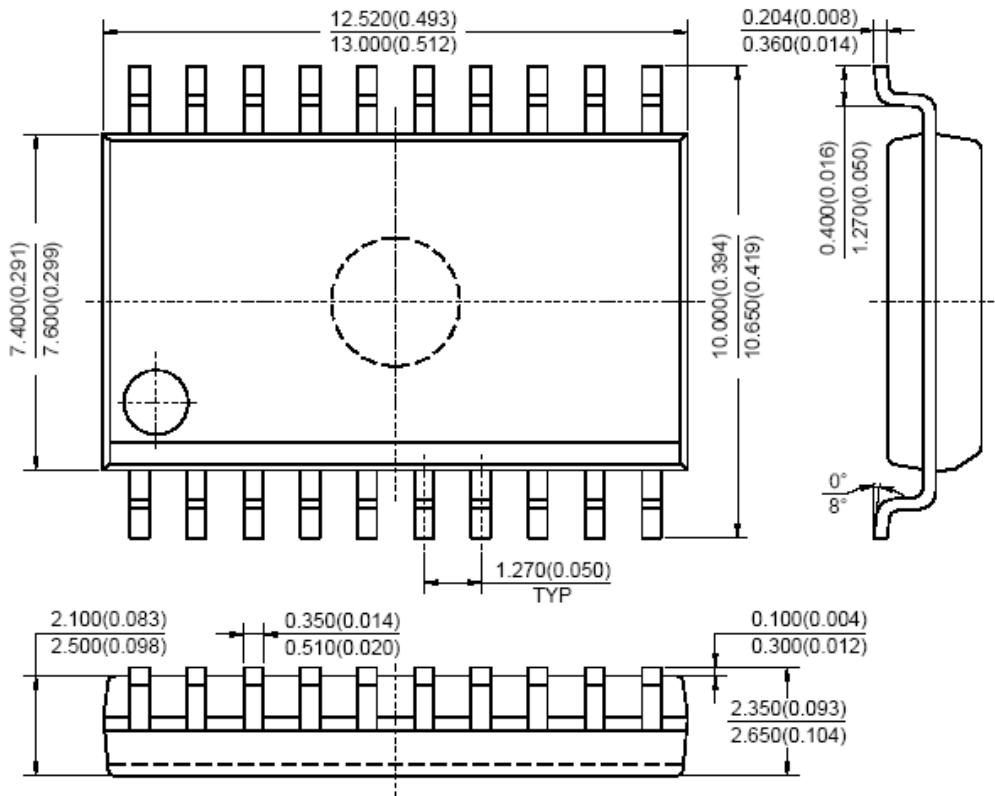

Note: Eject hole, oriented hole and mold mark is optional.



BCD Semiconductor Manufacturing Limited

<http://www.bcdsemi.com>

IMPORTANT NOTICE

BCD Semiconductor Manufacturing Limited reserves the right to make changes without further notice to any products or specifications herein. BCD Semiconductor Manufacturing Limited does not assume any responsibility for use of any its products for any particular purpose, nor does BCD Semiconductor Manufacturing Limited assume any liability arising out of the application or use of any its products or circuits. BCD Semiconductor Manufacturing Limited does not convey any license under its patent rights or other rights nor the rights of others.

MAIN SITE

- Headquarters

BCD Semiconductor Manufacturing Limited

No. 1600, Zi Xing Road, Shanghai Zizhu Science-based Industrial Park, 200241, China
Tel: +86-21-24162266, Fax: +86-21-24162277

- Wafer Fab

Shanghai SIM-BCD Semiconductor Manufacturing Co., Ltd.

800 Yi Shan Road, Shanghai 200233, China
Tel: +86-21-6485 1491, Fax: +86-21-5450 0008

REGIONAL SALES OFFICE

Shenzhen Office

Shanghai SIM-BCD Semiconductor Manufacturing Co., Ltd., Shenzhen Office

Unit A Room 1203, Skyworth Bldg., Gaoxin Ave. 1.S., Nanshan District, Shenzhen, China
Tel: +86-755-8826 7951
Fax: +86-755-8826 7865

Taiwan Office

BCD Semiconductor (Taiwan) Company Limited

4F, 298-1, Rui Guang Road, Nei-Hu District, Taipei, Taiwan
Tel: +886-2-2656 2808
Fax: +886-2-2656 2806

USA Office

BCD Semiconductor Corp.

30920 Huntwood Ave. Hayward, CA 94544, USA
Tel : +1-510-324-2988
Fax: +1-510-324-2788

Looking for pricing, stock, or lifecycle information?

Click below to explore more details on WIN SOURCE:

-  [View AP3608EFNTR-G1 on WIN SOURCE](#)
-  [Diodes Incorporated Information](#)

Optimize Your Supply Chain with WIN SOURCE Solutions

-  Global Sourcing Solution
-  Obsolete Management
-  Cost Control Management
-  Shortage Management
-  Alternative Solution
-  Excess Inventory Management