



THE DATASHEET OF LP211DR



LP211, LP311 LOW-POWER DIFFERENTIAL COMPARATORS WITH STROBES

SLCS003D – JUNE 1987 – REVISED SEPTEMBER 2003

- Low Power Drain . . . 900 μ W Typical With 5-V Supply
- Operates From ± 15 V or From a Single Supply as Low as 3 V
- Output Drive Capability of 25 mA
- Emitter Output Can Swing Below Negative Supply
- Response Time . . . 1.2 μ s Typ
- Low Input Currents:
Offset Current . . . 2 nA Typ
Bias Current . . . 15 nA Typ
- Wide Common-Mode Input Range:
–14.5 V to 13.5 V Using ± 15 -V Supply
- Offset Balancing and Strobe Capability
- Same Pinout as LM211, LM311
- Designed To Be Interchangeable With Industry-Standard LP311

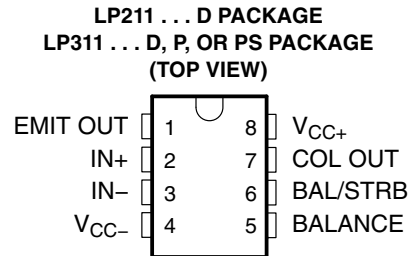

description/ordering information

The LP211 and LP311 devices are low-power versions of the industry-standard LM211 and LM311 devices. They take advantage of stable, high-value, ion-implanted resistors to perform the same function as the LM311 series, with a 30:1 reduction in power consumption, but only a 6:1 slowdown in response time. They are well suited for battery-powered applications and all other applications where fast response times are not needed. They operate over a wide range of supply voltages, from ± 18 V down to a single 3-V supply with less than 300- μ A current drain, but are still capable of driving a 25-mA load. The LP211 and LP311 are quite easy to apply free of oscillation if ordinary precautions are taken to minimize stray coupling from the output to either input or to the trim pins. In addition, offset balancing is available to minimize input offset voltage. Strobe capability also is provided to turn off the output (regardless of the inputs) by pulling the strobe pin low.

The LP211 is characterized for operation from -25°C to 85°C . The LP311 is characterized for operation from 0°C to 70°C .

ORDERING INFORMATION

T _A	V _{IO} max AT 25°C	PACKAGE†		ORDERABLE PART NUMBER	TOP-SIDE MARKING
–0°C to 70°C	7.5 mV	PDIP (P)	Tube of 50	LP311P	LP311P
		SOIC (D)	Tube of 75	LP311D	LP311
			Reel of 2500	LP311DR	
		SOP (PS)	Reel of 2000	LP311PSR	L311
–25°C to 85°C	7.5 mV	SOIC (D)	Tube of 75	LP211D	LP211
			Reel of 2500	LP211DR	

† Package drawings, standard packing quantities, thermal data, symbolization, and PCB design guidelines are available at www.ti.com/sc/package.

PRODUCTION DATA information is current as of publication date. Products conform to specifications per the terms of Texas Instruments standard warranty. Production processing does not necessarily include testing of all parameters.



POST OFFICE BOX 655303 • DALLAS, TEXAS 75265

Copyright © 2003, Texas Instruments Incorporated

LP211, LP311 LOW-POWER DIFFERENTIAL COMPARATORS WITH STROBES

SLCS003D – JUNE 1987 – REVISED SEPTEMBER 2003

functional block diagram

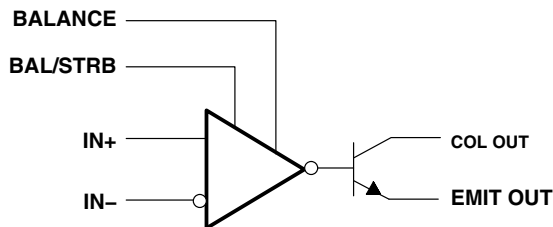

absolute maximum ratings over operating free-air temperature range (unless otherwise noted)[†]

Supply voltage (see Note 1): V_{CC+}	18 V
V_{CC-}	-18 V
Differential input voltage, V_{ID} (see Note 2)	± 30 V
Input voltage, V_I (either input, see Notes 1 and 3)	± 15 V
Voltage from emitter output to V_{CC-}	30 V
Voltage from collector output to V_{CC-}	40 V
Voltage from collector output to emitter output	40 V
Duration of output short circuit (see Note 4)	40 V
Package thermal impedance, θ_{JA} (see Notes 5 and 6): D package	97°C/W
P package	85°C/W
PS package	95°C/W
Operating virtual junction temperature, T_J	150°C
Storage temperature range, T_{stg}	-65°C to 150°C

[†] Stresses beyond those listed under absolute maximum ratings may cause permanent damage to the device. These are stress ratings only, and functional operation of the device at these or any other conditions beyond those indicated in the recommended operating conditions section of this specification is not implied. Exposure to absolute-maximum-rated conditions for extended periods may affect device reliability.

- NOTES:
1. All voltage values, unless otherwise noted, are with respect to the midpoint between V_{CC+} and V_{CC-} .
 2. Differential input voltages are at $IN+$ with respect to $IN-$.
 3. The magnitude of the input voltage must never exceed the magnitude of the supply voltage of ± 15 V, whichever is less.
 4. The output may be shorted to ground or to either power supply.
 5. Maximum power dissipation is a function of $T_J(max)$, θ_{JA} , and T_A . The maximum allowable power dissipation at any allowable ambient temperature is $P_D = (T_J(max) - T_A) / \theta_{JA}$. Operating at the absolute maximum T_J of 150°C can affect reliability.
 6. The package thermal impedance is calculated in accordance with JESD 51-7.

recommended operating conditions

		MIN	MAX	UNIT
$(V_{CC\pm} \leq 15 \text{ V})$	Input voltage	$V_{CC-} + 0.5$	$V_{CC+} - 1.5$	V
$V_{CC+} - V_{CC-}$	Supply voltage	3.5	30	V



LP211, LP311
LOW-POWER DIFFERENTIAL COMPARATORS
WITH STROBES

SLCS003D – JUNE 1987 – REVISED SEPTEMBER 2003

electrical characteristics at specified free-air temperature, $V_{CC\pm} = \pm 15$ V (unless otherwise noted)

PARAMETER		TEST CONDITIONS		T_A	MIN	TYP†	MAX	UNIT
V_{ID}	Input offset voltage	RS < 100 k Ω ,	See Note 7	25°C		2	7.5	mV
				Full range			10	
V_{OL}	Low-level output voltage	$V_{ID} < -10$ mV, See Note 8	$I_{OL} = 25$ mA, $V_{CC-} = 0$, $I_{OL} = 1.6$ mA, See Note 8	25°C		0.4	1.5	V
				Full range		0.1	0.4	
I_{IO}	Input offset current	See Note 7		25°C		2	25	nA
				Full range			35	
I_{IB}	Input bias current			25°C		15	100	nA
				Full range			150	
	Low-level strobe current	$V_{(strobe)} = 0.3$ V, See Note 9	$V_{ID} < -10$ mV,	25°C		100	300	μ A
$I_{O(off)}$	Output off-state current	$V_{ID} > 10$ mV,	$V_{CE} = 35$ V	25°C		0.2	100	nA
A_{VD}	Large-signal differential-voltage amplification	$R_L = 5$ k Ω		25°C	40	100		V/mV
I_{CC+}	Supply current from V_{CC+}	$V_{ID} = -50$ mV,	$R_L = \infty$	Full range		150	300	μ A
I_{CC-}	Supply current from V_{CC-}	$V_{ID} = 50$ mV,	$R_L = \infty$	Full range		- 80	- 180	μ A

† All typical values are at $V_{CC\pm} = \pm 15$ V, $T_A = 25^\circ\text{C}$.

NOTES: 7. The offset voltages and offset currents given are the maximum values required to drive the output within 1 V of either supply with a 1-mA load. Thus, these parameters define an error band and take into account the worst-case effects of voltage gain and input impedance.

8. Voltages are with respect to EMIT OUT and V_{CC-} tied together.

9. The strobe should not be shorted to ground; it should be current driven at 100 μ A to 300 μ A.

switching characteristics, $V_{CC\pm} = \pm 5$ V, $T_A = 25^\circ\text{C}$ (unless otherwise noted)

PARAMETER	TEST CONDITIONS	TYP	UNIT
Response time	See Note 10	1.2	μ s

NOTE 10: The response time is specified for a 100-mV input step with 5-mV overdrive.



LP211, LP311 LOW-POWER DIFFERENTIAL COMPARATORS WITH STROBES

SLCS003D – JUNE 1987 – REVISED SEPTEMBER 2003

TYPICAL APPLICATION CIRCUIT

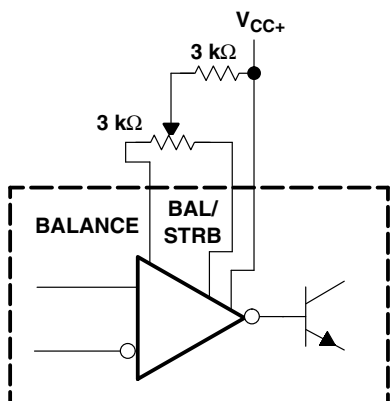

NOTE: If offset balancing is not used, the BALANCE and BAL/STRB pins should be shorted together.

Figure 1. Offset Balancing

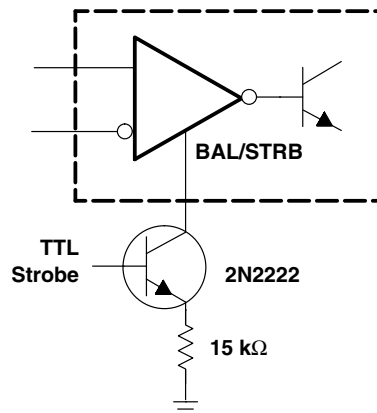

NOTE: Do not connect strobe pin directly to ground, because the output is turned off whenever current is pulled from the strobe pin.

Figure 2. Strobing

PACKAGING INFORMATION

Orderable Device	Status (1)	Package Type	Package Drawing	Pins	Package Qty	Eco Plan (2)	Lead finish/ Ball material (6)	MSL Peak Temp (3)	Op Temp (°C)	Device Marking (4/5)	Samples
LP211D	ACTIVE	SOIC	D	8	75	RoHS & Green	NIPDAU	Level-1-260C-UNLIM	-25 to 85	LP211	Samples
LP211DR	ACTIVE	SOIC	D	8	2500	RoHS & Green	NIPDAU	Level-1-260C-UNLIM	-25 to 85	LP211	Samples
LP211DRG4	ACTIVE	SOIC	D	8	2500	TBD	Call TI	Call TI	-25 to 85		Samples
LP311D	ACTIVE	SOIC	D	8	75	RoHS & Green	NIPDAU	Level-1-260C-UNLIM	0 to 70	LP311	Samples
LP311DR	ACTIVE	SOIC	D	8	2500	RoHS & Green	NIPDAU	Level-1-260C-UNLIM	0 to 70	LP311	Samples
LP311P	ACTIVE	PDIP	P	8	50	RoHS & Green	NIPDAU	N / A for Pkg Type	0 to 70	LP311P	Samples
LP311PE4	ACTIVE	PDIP	P	8	50	TBD	Call TI	Call TI	0 to 70		Samples

(1) The marketing status values are defined as follows:

ACTIVE: Product device recommended for new designs.

LIFEBUY: TI has announced that the device will be discontinued, and a lifetime-buy period is in effect.

NRND: Not recommended for new designs. Device is in production to support existing customers, but TI does not recommend using this part in a new design.

PREVIEW: Device has been announced but is not in production. Samples may or may not be available.

OBSOLETE: TI has discontinued the production of the device.

(2) **RoHS:** TI defines "RoHS" to mean semiconductor products that are compliant with the current EU RoHS requirements for all 10 RoHS substances, including the requirement that RoHS substance do not exceed 0.1% by weight in homogeneous materials. Where designed to be soldered at high temperatures, "RoHS" products are suitable for use in specified lead-free processes. TI may reference these types of products as "Pb-Free".

RoHS Exempt: TI defines "RoHS Exempt" to mean products that contain lead but are compliant with EU RoHS pursuant to a specific EU RoHS exemption.

Green: TI defines "Green" to mean the content of Chlorine (Cl) and Bromine (Br) based flame retardants meet JS709B low halogen requirements of <=1000ppm threshold. Antimony trioxide based flame retardants must also meet the <=1000ppm threshold requirement.

(3) MSL, Peak Temp. - The Moisture Sensitivity Level rating according to the JEDEC industry standard classifications, and peak solder temperature.

(4) There may be additional marking, which relates to the logo, the lot trace code information, or the environmental category on the device.

(5) Multiple Device Markings will be inside parentheses. Only one Device Marking contained in parentheses and separated by a "~" will appear on a device. If a line is indented then it is a continuation of the previous line and the two combined represent the entire Device Marking for that device.

⁽⁶⁾ Lead finish/Ball material - Orderable Devices may have multiple material finish options. Finish options are separated by a vertical ruled line. Lead finish/Ball material values may wrap to two lines if the finish value exceeds the maximum column width.

Important Information and Disclaimer:The information provided on this page represents TI's knowledge and belief as of the date that it is provided. TI bases its knowledge and belief on information provided by third parties, and makes no representation or warranty as to the accuracy of such information. Efforts are underway to better integrate information from third parties. TI has taken and continues to take reasonable steps to provide representative and accurate information but may not have conducted destructive testing or chemical analysis on incoming materials and chemicals. TI and TI suppliers consider certain information to be proprietary, and thus CAS numbers and other limited information may not be available for release.

In no event shall TI's liability arising out of such information exceed the total purchase price of the TI part(s) at issue in this document sold by TI to Customer on an annual basis.

TAPE AND REEL INFORMATION

QUADRANT ASSIGNMENTS FOR PIN 1 ORIENTATION IN TAPE

*All dimensions are nominal

Device	Package Type	Package Drawing	Pins	SPQ	Reel Diameter (mm)	Reel Width W1 (mm)	A0 (mm)	B0 (mm)	K0 (mm)	P1 (mm)	W (mm)	Pin1 Quadrant
LP211DR	SOIC	D	8	2500	330.0	12.4	6.4	5.2	2.1	8.0	12.0	Q1
LP311DR	SOIC	D	8	2500	330.0	12.4	6.4	5.2	2.1	8.0	12.0	Q1

TAPE AND REEL BOX DIMENSIONS



*All dimensions are nominal

Device	Package Type	Package Drawing	Pins	SPQ	Length (mm)	Width (mm)	Height (mm)
LP211DR	SOIC	D	8	2500	340.5	338.1	20.6
LP311DR	SOIC	D	8	2500	340.5	338.1	20.6

TUBE

*All dimensions are nominal

Device	Package Name	Package Type	Pins	SPQ	L (mm)	W (mm)	T (μm)	B (mm)
LP211D	D	SOIC	8	75	507	8	3940	4.32
LP311D	D	SOIC	8	75	507	8	3940	4.32
LP311P	P	PDIP	8	50	506	13.97	11230	4.32



D0008A

PACKAGE OUTLINE

SOIC - 1.75 mm max height

SMALL OUTLINE INTEGRATED CIRCUIT



4214825/C 02/2019

NOTES:

1. Linear dimensions are in inches [millimeters]. Dimensions in parenthesis are for reference only. Controlling dimensions are in inches. Dimensioning and tolerancing per ASME Y14.5M.
2. This drawing is subject to change without notice.
3. This dimension does not include mold flash, protrusions, or gate burrs. Mold flash, protrusions, or gate burrs shall not exceed .006 [0.15] per side.
4. This dimension does not include interlead flash.
5. Reference JEDEC registration MS-012, variation AA.

EXAMPLE BOARD LAYOUT

D0008A

SOIC - 1.75 mm max height

SMALL OUTLINE INTEGRATED CIRCUIT



LAND PATTERN EXAMPLE
 EXPOSED METAL SHOWN
 SCALE:8X



SOLDER MASK DETAILS

4214825/C 02/2019

NOTES: (continued)

- 6. Publication IPC-7351 may have alternate designs.
- 7. Solder mask tolerances between and around signal pads can vary based on board fabrication site.

EXAMPLE STENCIL DESIGN

D0008A

SOIC - 1.75 mm max height

SMALL OUTLINE INTEGRATED CIRCUIT



SOLDER PASTE EXAMPLE
BASED ON .005 INCH [0.125 MM] THICK STENCIL
SCALE:8X

4214825/C 02/2019

NOTES: (continued)

8. Laser cutting apertures with trapezoidal walls and rounded corners may offer better paste release. IPC-7525 may have alternate design recommendations.
9. Board assembly site may have different recommendations for stencil design.

P (R-PDIP-T8)

PLASTIC DUAL-IN-LINE PACKAGE

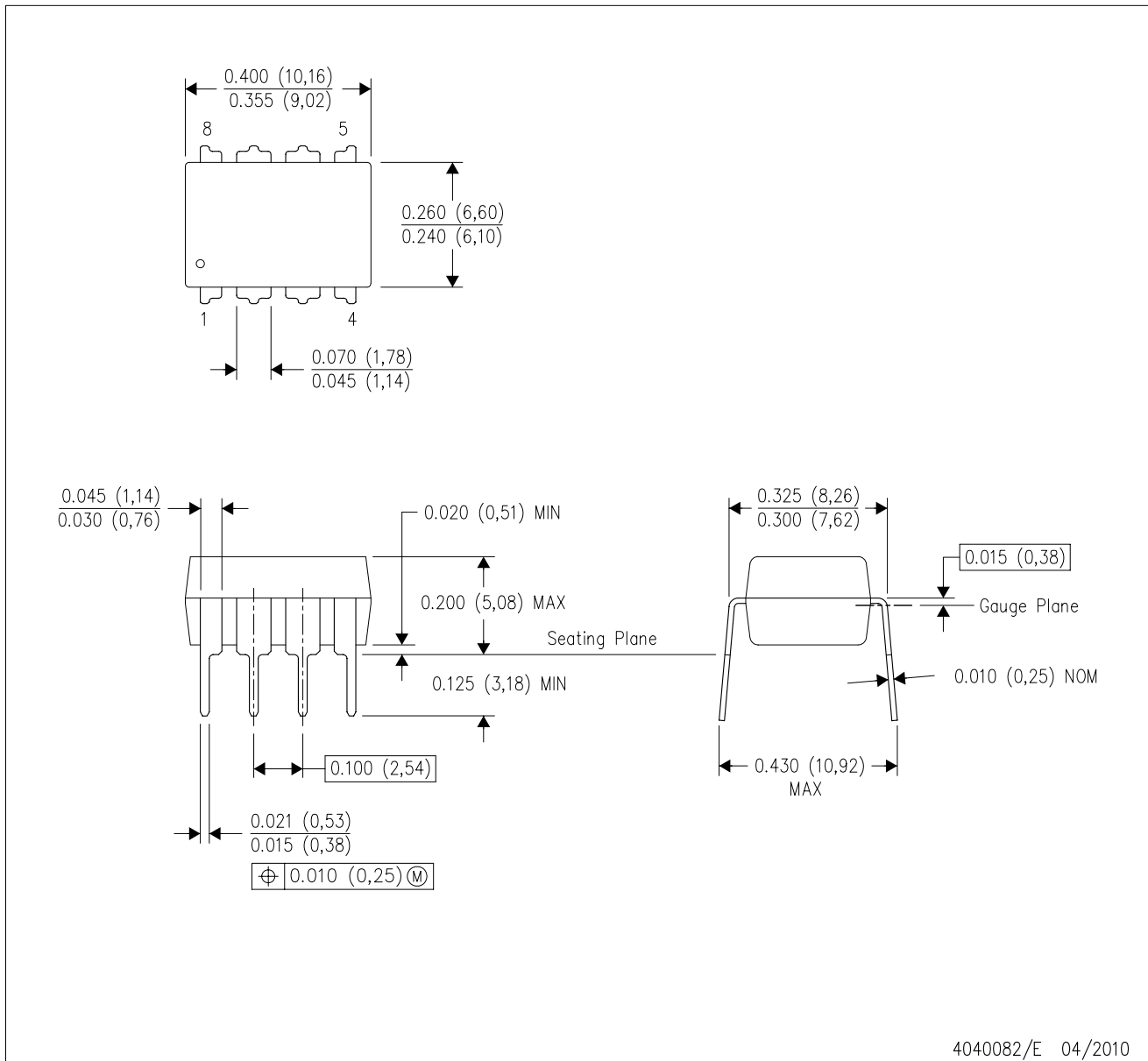

- NOTES:
- A. All linear dimensions are in inches (millimeters).
 - B. This drawing is subject to change without notice.
 - C. Falls within JEDEC MS-001 variation BA.

IMPORTANT NOTICE AND DISCLAIMER

TI PROVIDES TECHNICAL AND RELIABILITY DATA (INCLUDING DATA SHEETS), DESIGN RESOURCES (INCLUDING REFERENCE DESIGNS), APPLICATION OR OTHER DESIGN ADVICE, WEB TOOLS, SAFETY INFORMATION, AND OTHER RESOURCES "AS IS" AND WITH ALL FAULTS, AND DISCLAIMS ALL WARRANTIES, EXPRESS AND IMPLIED, INCLUDING WITHOUT LIMITATION ANY IMPLIED WARRANTIES OF MERCHANTABILITY, FITNESS FOR A PARTICULAR PURPOSE OR NON-INFRINGEMENT OF THIRD PARTY INTELLECTUAL PROPERTY RIGHTS.

These resources are intended for skilled developers designing with TI products. You are solely responsible for (1) selecting the appropriate TI products for your application, (2) designing, validating and testing your application, and (3) ensuring your application meets applicable standards, and any other safety, security, regulatory or other requirements.

These resources are subject to change without notice. TI grants you permission to use these resources only for development of an application that uses the TI products described in the resource. Other reproduction and display of these resources is prohibited. No license is granted to any other TI intellectual property right or to any third party intellectual property right. TI disclaims responsibility for, and you will fully indemnify TI and its representatives against, any claims, damages, costs, losses, and liabilities arising out of your use of these resources.

TI's products are provided subject to [TI's Terms of Sale](#) or other applicable terms available either on [ti.com](https://www.ti.com) or provided in conjunction with such TI products. TI's provision of these resources does not expand or otherwise alter TI's applicable warranties or warranty disclaimers for TI products.

TI objects to and rejects any additional or different terms you may have proposed.

Mailing Address: Texas Instruments, Post Office Box 655303, Dallas, Texas 75265
Copyright © 2023, Texas Instruments Incorporated

Looking for pricing, stock, or lifecycle information?

Click below to explore more details on WIN SOURCE:

 [View LP211DR](#) on WIN SOURCE

 [Texas Instruments](#) Information

Optimize Your Supply Chain with WIN SOURCE Solutions

-  Global Sourcing Solution
-  Obsolete Management
-  Cost Control Management
-  Shortage Management
-  Alternative Solution
-  Excess Inventory Management