



**THE DATASHEET OF  
CY62147EV30LL-45BVI**





**Please note that Cypress is an Infineon Technologies Company.**

The document following this cover page is marked as “Cypress” document as this is the company that originally developed the product. Please note that Infineon will continue to offer the product to new and existing customers as part of the Infineon product portfolio.

**Continuity of document content**

The fact that Infineon offers the following product as part of the Infineon product portfolio does not lead to any changes to this document. Future revisions will occur when appropriate, and any changes will be set out on the document history page.

**Continuity of ordering part numbers**

Infineon continues to support existing part numbers. Please continue to use the ordering part numbers listed in the datasheet for ordering.

# 4-Mbit (256K × 16) Static RAM

## Features

- Very high speed: 45 ns
- Temperature ranges
  - Industrial: -40 °C to +85 °C
- Wide voltage range: 2.20 V to 3.60 V
- Pin compatible with CY62147DV30
- Ultra low standby power
  - Typical standby current: 2.5 μA
  - Maximum standby current: 7 μA (Industrial)
- Ultra low active power
  - Typical active current: 3.5 mA at f = 1 MHz
- Easy memory expansion with  $\overline{CE}$  [1] and  $\overline{OE}$  features
- Automatic power-down when deselected
- Complementary metal oxide semiconductor (CMOS) for optimum speed and power
- Available in Pb-free 48-ball very fine ball grid array (VFBGA) (single/dual CE option) and 44-pin thin small outline package (TSOP) II packages
- Byte power-down feature

## Functional Description

The CY62147EV30 is a high performance CMOS static RAM (SRAM) organized as 256K words by 16 bits. This device features advanced circuit design to provide ultra low active current. It is ideal for providing More Battery Life™ (MoBL®) in

portable applications such as cellular telephones. The device also has an automatic power down feature that significantly reduces power consumption when addresses are not toggling. Placing the device into standby mode reduces power consumption by more than 99 percent when deselected ( $\overline{CE}$  HIGH or both  $\overline{BLE}$  and  $\overline{BHE}$  are HIGH). The input and output pins (I/O<sub>0</sub> through I/O<sub>15</sub>) are placed in a high impedance state when:

- Deselected ( $\overline{CE}$  HIGH)
- Outputs are disabled ( $\overline{OE}$  HIGH)
- Both Byte High Enable and Byte Low Enable are disabled ( $\overline{BHE}$ ,  $\overline{BLE}$  HIGH)
- Write operation is active ( $\overline{CE}$  LOW and  $\overline{WE}$  LOW)

To write to the device, take Chip Enable ( $\overline{CE}$ ) and Write Enable ( $\overline{WE}$ ) inputs LOW. If Byte Low Enable ( $\overline{BLE}$ ) is LOW, then data from I/O pins (I/O<sub>0</sub> through I/O<sub>7</sub>) is written into the location specified on the address pins (A<sub>0</sub> through A<sub>17</sub>). If Byte High Enable ( $\overline{BHE}$ ) is LOW, then data from I/O pins (I/O<sub>8</sub> through I/O<sub>15</sub>) is written into the location specified on the address pins (A<sub>0</sub> through A<sub>17</sub>).

To read from the device, take Chip Enable ( $\overline{CE}$ ) and Output Enable ( $\overline{OE}$ ) LOW while forcing the Write Enable ( $\overline{WE}$ ) HIGH. If Byte Low enable ( $\overline{BLE}$ ) is LOW, then data from the memory location specified by the address pins appear on I/O<sub>0</sub> to I/O<sub>7</sub>. If Byte High enable ( $\overline{BHE}$ ) is LOW, then data from memory appears on I/O<sub>8</sub> to I/O<sub>15</sub>. See the Truth Table on page 11 for a complete description of read and write modes.

For a complete list of related documentation, [click here](#).

## Logic Block Diagram

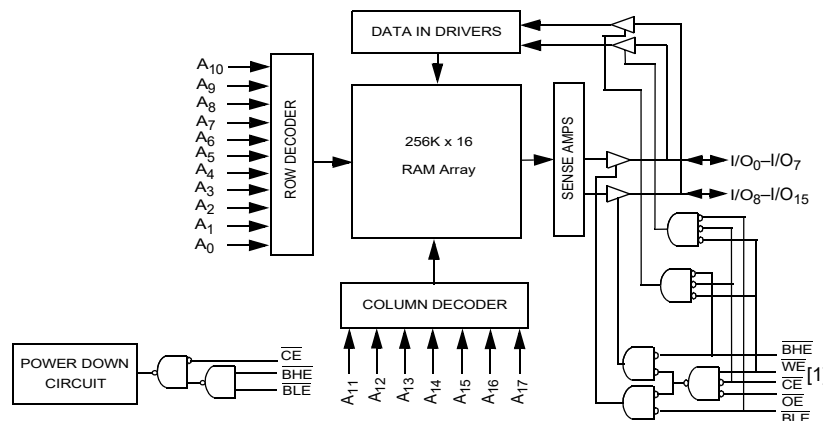

### Note

1. BGA packaged device is offered in single CE and dual CE options. In this data sheet, for a dual CE device,  $\overline{CE}$  refers to the internal logical combination of  $\overline{CE}_1$  and  $\overline{CE}_2$  such that when  $\overline{CE}_1$  is LOW and  $\overline{CE}_2$  is HIGH,  $\overline{CE}$  is LOW. For all other cases  $\overline{CE}$  is HIGH.

## Contents

<b>Product Portfolio</b> .....	<b>3</b>	<b>Ordering Information</b> .....	<b>12</b>
<b>Pin Configurations</b> .....	<b>3</b>	Ordering Code Definitions .....	12
<b>Maximum Ratings</b> .....	<b>4</b>	<b>Package Diagrams</b> .....	<b>13</b>
<b>Operating Range</b> .....	<b>4</b>	<b>Acronyms</b> .....	<b>15</b>
<b>Electrical Characteristics</b> .....	<b>4</b>	<b>Document Conventions</b> .....	<b>15</b>
<b>Capacitance</b> .....	<b>5</b>	Units of Measure .....	15
<b>Thermal Resistance</b> .....	<b>5</b>	<b>Document History Page</b> .....	<b>16</b>
<b>AC Test Load and Waveforms</b> .....	<b>5</b>	<b>Sales, Solutions, and Legal Information</b> .....	<b>20</b>
<b>Data Retention Characteristics</b> .....	<b>6</b>	Worldwide Sales and Design Support .....	20
<b>Data Retention Waveform</b> .....	<b>6</b>	Products .....	20
<b>Switching Characteristics</b> .....	<b>7</b>	PSoC® Solutions .....	20
<b>Switching Waveforms</b> .....	<b>8</b>	Cypress Developer Community .....	20
<b>Truth Table</b> .....	<b>11</b>	Technical Support .....	20

### Product Portfolio

Product	Range	V <sub>CC</sub> Range (V)			Speed (ns)	Power Dissipation					
						Operating I <sub>CC</sub> (mA)				Standby I <sub>SB2</sub> (μA)	
		f = 1 MHz		f = f <sub>max</sub>							
		Min	Typ <sup>[2]</sup>	Max		Typ <sup>[2]</sup>	Max	Typ <sup>[2]</sup>	Max	Typ <sup>[2]</sup>	Max
CY62147EV30LL	Industrial	2.2	3.0	3.6	45	3.5	6	15	20	2.5	7

### Pin Configurations

Figure 1. 48-ball VFBGA pinout (Single Chip Enable)<sup>[3, 4]</sup>

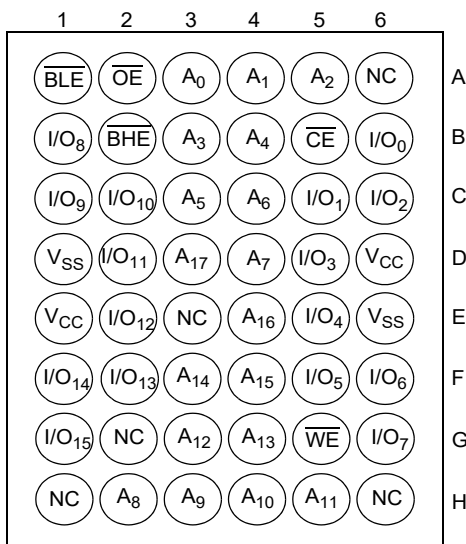

Figure 2. 48-ball VFBGA pinout (Dual Chip Enable)<sup>[3, 4]</sup>

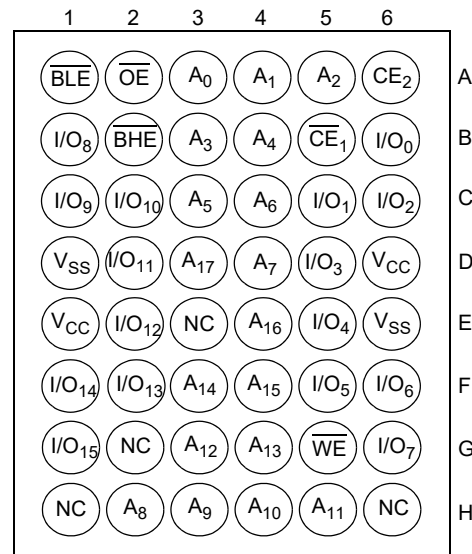
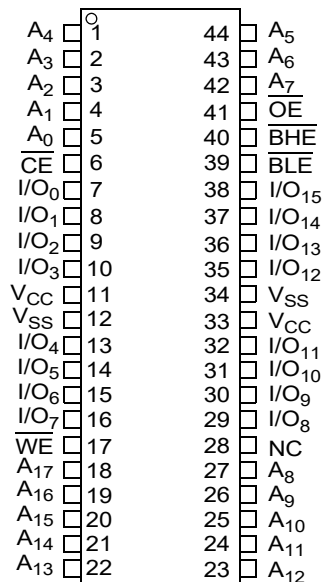

Figure 3. 44-pin TSOP II pinout<sup>[3]</sup>



**Notes**

- 2. Typical values are included for reference only and are not guaranteed or tested. Typical values are measured at V<sub>CC</sub> = V<sub>CC(typ)</sub>, T<sub>A</sub> = 25 °C.
- 3. NC pins are not connected on the die.
- 4. Pins H1, G2, and H6 in the BGA package are address expansion pins for 8Mb, 16Mb, and 32Mb, respectively.

## Maximum Ratings

Exceeding the maximum ratings may impair the useful life of the device. User guidelines are not tested.

Storage temperature ..... -65 °C to + 150 °C  
 Ambient temperature  
 with power applied ..... -55 °C to +125 °C  
 Supply voltage  
 to ground potential ..... -0.3 V to + 3.9 V ( $V_{CC(max)}$  + 0.3 V)  
 DC voltage applied to outputs  
 in High Z state <sup>[5, 6]</sup> ..... -0.3 V to 3.9 V ( $V_{CC(max)}$  + 0.3 V)

DC input voltage <sup>[5, 6]</sup> ..... -0.3 V to 3.9 V ( $V_{CC(max)}$  + 0.3 V)  
 Output current into outputs (LOW) ..... 20 mA  
 Static discharge voltage  
 (MIL-STD-883, method 3015) ..... > 2001 V  
 Latch-up current ..... > 200 mA

## Operating Range

Device	Range	Ambient Temperature	V <sub>CC</sub> <sup>[7]</sup>
CY62147EV30LL	Industrial	-40 °C to +85 °C	2.2 V to 3.6 V

## Electrical Characteristics

Over the Operating Range

Parameter	Description	Test Conditions	45 ns (Industrial)			Unit
			Min	Typ <sup>[8]</sup>	Max	
V <sub>OH</sub>	Output HIGH voltage	I <sub>OH</sub> = -0.1 mA	2.0	-	-	V
		I <sub>OH</sub> = -1.0 mA, V <sub>CC</sub> ≥ 2.70 V	2.4	-	-	V
V <sub>OL</sub>	Output LOW voltage	I <sub>OL</sub> = 0.1 mA	-	-	0.4	V
		I <sub>OL</sub> = 2.1 mA, V <sub>CC</sub> = 2.70 V	-	-	0.4	V
V <sub>IH</sub>	Input HIGH voltage	V <sub>CC</sub> = 2.2 V to 2.7 V	1.8	-	V <sub>CC</sub> + 0.3	V
		V <sub>CC</sub> = 2.7 V to 3.6 V	2.2	-	V <sub>CC</sub> + 0.3	V
V <sub>IL</sub>	Input LOW voltage	V <sub>CC</sub> = 2.2 V to 2.7 V	-0.3	-	0.6	V
		V <sub>CC</sub> = 2.7 V to 3.6 V	-0.3	-	0.8	V
I <sub>IX</sub>	Input leakage current	GND ≤ V <sub>I</sub> ≤ V <sub>CC</sub>	-1	-	+1	μA
I <sub>OZ</sub>	Output leakage current	GND ≤ V <sub>O</sub> ≤ V <sub>CC</sub> , output disabled	-1	-	+1	μA
I <sub>CC</sub>	V <sub>CC</sub> operating supply current	f = f <sub>max</sub> = 1/t <sub>RC</sub> V <sub>CC</sub> = V <sub>CC(max)</sub> I <sub>OUT</sub> = 0 mA	-	15	20	mA
		f = 1 MHz      CMOS levels	-	3.5	6	
I <sub>SB1</sub> <sup>[9]</sup>	Automatic $\overline{CE}$ power-down current – CMOS inputs	$\overline{CE} \geq V_{CC} - 0.2$ V, V <sub>IN</sub> ≥ V <sub>CC</sub> - 0.2 V, V <sub>IN</sub> ≤ 0.2 V, f = f <sub>max</sub> (address and data only),  f = 0 ( $\overline{OE}$ , $\overline{BHE}$ , $\overline{BLE}$ and $\overline{WE}$ ), V <sub>CC</sub> = 3.60 V	-	2.5	7	μA
I <sub>SB2</sub> <sup>[9]</sup>	Automatic $\overline{CE}$ power-down current – CMOS inputs	$\overline{CE} \geq V_{CC} - 0.2$ V, V <sub>IN</sub> ≥ V <sub>CC</sub> - 0.2 V or V <sub>IN</sub> ≤ 0.2 V, f = 0, V <sub>CC</sub> = 3.60 V	-	2.5	7	μA

### Notes

- V<sub>IL(min)</sub> = -2.0 V for pulse durations less than 20 ns.
- V<sub>IH(max)</sub> = V<sub>CC</sub> + 0.75 V for pulse durations less than 20 ns.
- Full device AC operation assumes a minimum of 100 μs ramp time from 0 to V<sub>CC(min)</sub> and 200 μs wait time after V<sub>CC</sub> stabilization.
- Typical values are included for reference only and are not guaranteed or tested. Typical values are measured at V<sub>CC</sub> = V<sub>CC(typ)</sub>, T<sub>A</sub> = 25 °C.
- Chip enable (CE) and byte enables (BHE and BLE) need to be tied to CMOS levels to meet the I<sub>SB1</sub> / I<sub>SB2</sub> / I<sub>CCDR</sub> spec. Other inputs can be left floating.

### Capacitance

Parameter <sup>[10]</sup>	Description	Test Conditions	Max	Unit
C <sub>IN</sub>	Input capacitance	T <sub>A</sub> = 25 °C, f = 1 MHz, V <sub>CC</sub> = V <sub>CC(typ)</sub>	10	pF
C <sub>OUT</sub>	Output capacitance		10	pF

### Thermal Resistance

Parameter <sup>[10]</sup>	Description	Test Conditions	48-ball VFBGA Package	44-pin TSOP II Package	Unit
Θ <sub>JA</sub>	Thermal resistance (junction to ambient)	Still Air, soldered on a 3 × 4.5 inch, two-layer printed circuit board	42.10	55.52	°C/W
Θ <sub>JC</sub>	Thermal resistance (junction to case)		23.45	16.03	°C/W

### AC Test Load and Waveforms

Figure 4. AC Test Load and Waveforms

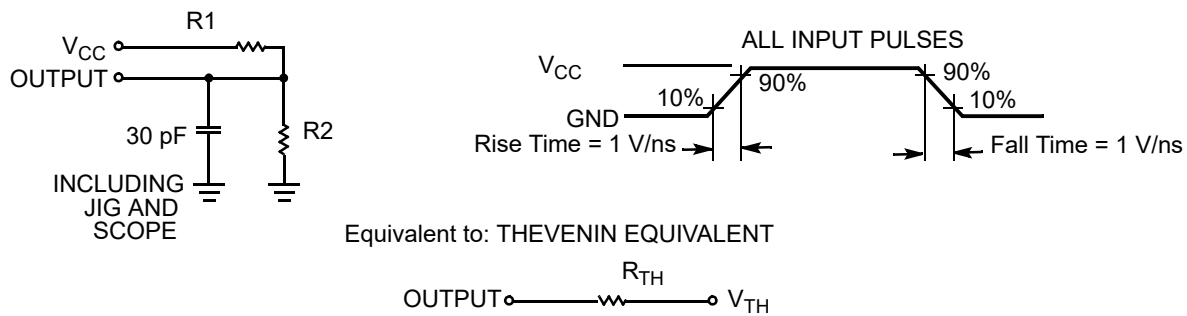

Parameters	2.50 V	3.0 V	Unit
R1	16667	1103	Ω
R2	15385	1554	Ω
R <sub>TH</sub>	8000	645	Ω
V <sub>TH</sub>	1.20	1.75	V

**Note**

10. Tested initially and after any design or process changes that may affect these parameters.

## Data Retention Characteristics

Over the Operating Range

Parameter	Description	Conditions	Min	Typ <sup>[11]</sup>	Max	Unit
$V_{DR}$	$V_{CC}$ for data retention		1.5	–	–	V
$I_{CCDR}$ <sup>[12]</sup>	Data retention current	$V_{CC} = 1.5\text{ V}$ , $\overline{CE} \geq V_{CC} - 0.2\text{ V}$ , $V_{IN} \geq V_{CC} - 0.2\text{ V}$ or $V_{IN} \leq 0.2\text{ V}$	–	3	8.8	$\mu\text{A}$
$t_{CDR}$ <sup>[13]</sup>	Chip deselect to data retention time		0	–	–	ns
$t_R$ <sup>[14]</sup>	Operation recovery time		45	–	–	ns

## Data Retention Waveform

Figure 5. Data Retention Waveform<sup>[15, 16]</sup>

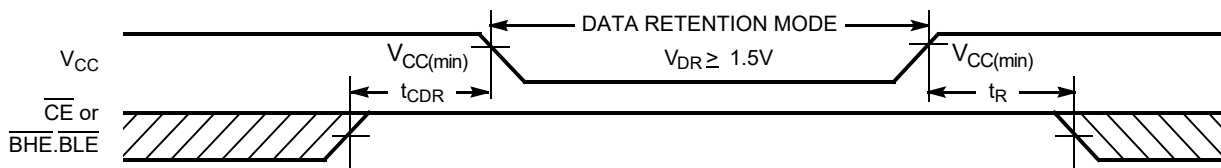

### Notes

11. Typical values are included for reference only and are not guaranteed or tested. Typical values are measured at  $V_{CC} = V_{CC(\text{typ})}$ ,  $T_A = 25^\circ\text{C}$ .
12. Chip enable ( $\overline{CE}$ ) and byte enables ( $\overline{BHE}$  and  $\overline{BLE}$ ) need to be tied to CMOS levels to meet the  $I_{SB1}$  /  $I_{SB2}$  /  $I_{CCDR}$  spec. Other inputs can be left floating.
13. Tested initially and after any design or process changes that may affect these parameters.
14. Full device operation requires linear  $V_{CC}$  ramp from  $V_{DR}$  to  $V_{CC(\text{min})} \geq 100\ \mu\text{s}$  or stable at  $V_{CC(\text{min})} \geq 100\ \mu\text{s}$ .
15. BGA packaged device is offered in single CE and dual CE options. In this data sheet, for a dual CE device,  $\overline{CE}$  refers to the internal logical combination of  $\overline{CE}_1$  and  $\overline{CE}_2$  such that when  $\overline{CE}_1$  is LOW and  $\overline{CE}_2$  is HIGH, CE is LOW. For all other cases CE is HIGH.
16.  $\overline{BHE.BLE}$  is the AND of both  $\overline{BHE}$  and  $\overline{BLE}$ . Deselect the chip by either disabling the chip enable signals or by disabling both  $\overline{BHE}$  and  $\overline{BLE}$ .

## Switching Characteristics

Over the Operating Range

Parameter [17, 18]	Description	45 ns (Industrial)		Unit
		Min	Max	
<b>Read Cycle</b>				
$t_{RC}$	Read cycle time	45	–	ns
$t_{AA}$	Address to data valid	–	45	ns
$t_{OHA}$	Data hold from address change	10	–	ns
$t_{ACE}$	$\overline{CE}$ LOW to data valid	–	45	ns
$t_{DOE}$	$\overline{OE}$ LOW to data valid	–	22	ns
$t_{LZOE}$	$\overline{OE}$ LOW to low Z [19]	5	–	ns
$t_{HZOE}$	$\overline{OE}$ HIGH to high Z [19, 20]	–	18	ns
$t_{LZCE}$	$\overline{CE}$ LOW to low Z [19]	10	–	ns
$t_{HZCE}$	$\overline{CE}$ HIGH to high Z [19, 20]	–	18	ns
$t_{PU}$	$\overline{CE}$ LOW to power-up	0	–	ns
$t_{PD}$	$\overline{CE}$ HIGH to power-down	–	45	ns
$t_{DBE}$	$\overline{BLE}/\overline{BHE}$ LOW to data valid	–	45	ns
$t_{LZBE}$	$\overline{BLE}/\overline{BHE}$ LOW to low Z [19, 21]	5	–	ns
$t_{HZBE}$	$\overline{BLE}/\overline{BHE}$ HIGH to high Z [19, 20]	–	18	ns
<b>Write Cycle [22, 23]</b>				
$t_{WC}$	Write cycle time	45	–	ns
$t_{SCE}$	$\overline{CE}$ LOW to write end	35	–	ns
$t_{AW}$	Address setup to write end	35	–	ns
$t_{HA}$	Address hold from write end	0	–	ns
$t_{SA}$	Address setup to write start	0	–	ns
$t_{PWE}$	$\overline{WE}$ pulse width	35	–	ns
$t_{BW}$	$\overline{BLE}/\overline{BHE}$ LOW to write end	35	–	ns
$t_{SD}$	Data setup to write end	25	–	ns
$t_{HD}$	Data hold from write end	0	–	ns
$t_{HZWE}$	$\overline{WE}$ LOW to high Z [19, 20]	–	18	ns
$t_{LZWE}$	$\overline{WE}$ HIGH to low Z [19]	10	–	ns

### Notes

17. Test conditions for all parameters other than tri-state parameters assume signal transition time of 3 ns (1V/ns) or less, timing reference levels of  $V_{CC(typ)}/2$ , input pulse levels of 0 to  $V_{CC(typ)}$ , and output loading of the specified  $I_{OL}/I_{OH}$  as shown in the [Figure 4 on page 5](#).
18. In an earlier revision of this device, under a specific application condition, READ and WRITE operations were limited to switching of the byte enable and/or chip enable signals as described in the Application Notes [AN13842](#) and [AN66311](#). However, the issue has been fixed and in production now, and hence, these Application Notes are no longer applicable. They are available for download on our website as they contain information on the date code of the parts, beyond which the fix has been in production.
19. At any temperature and voltage condition,  $t_{HZCE}$  is less than  $t_{LZCE}$ ,  $t_{HZBE}$  is less than  $t_{LZBE}$ ,  $t_{HZOE}$  is less than  $t_{LZOE}$ , and  $t_{HZWE}$  is less than  $t_{LZWE}$  for any device.
20.  $t_{HZOE}$ ,  $t_{HZCE}$ ,  $t_{HZBE}$ , and  $t_{HZWE}$  transitions are measured when the outputs enter a high impedance state.
21. If both byte enables are toggled together, this value is 10 ns.
22. The internal write time of the memory is defined by the overlap of  $\overline{WE}$ ,  $\overline{CE} = V_{IL}$ ,  $\overline{BHE}$ ,  $\overline{BLE}$ , or both =  $V_{IL}$ . All signals must be active to initiate a write and any of these signals can terminate a write by going inactive. The data input setup and hold timing must be referenced to the edge of the signal that terminates the write.
23. The minimum write cycle pulse width for Write Cycle No. 3 ( $\overline{WE}$  Controlled,  $\overline{OE}$  LOW) should be equal to the sum of  $t_{SD}$  and  $t_{HZWE}$ .

## Switching Waveforms

Figure 6. Read Cycle No. 1 (Address Transition Controlled) [24, 25]

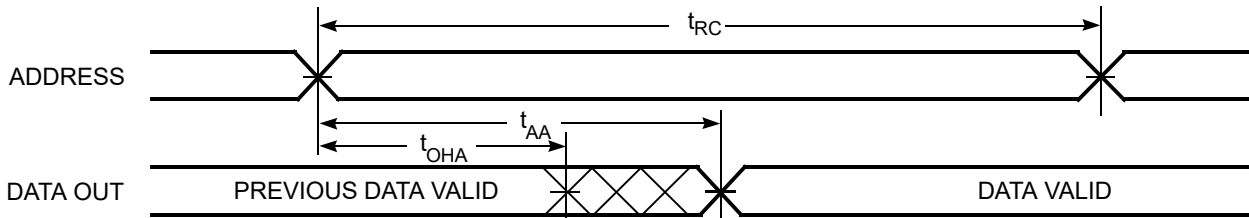
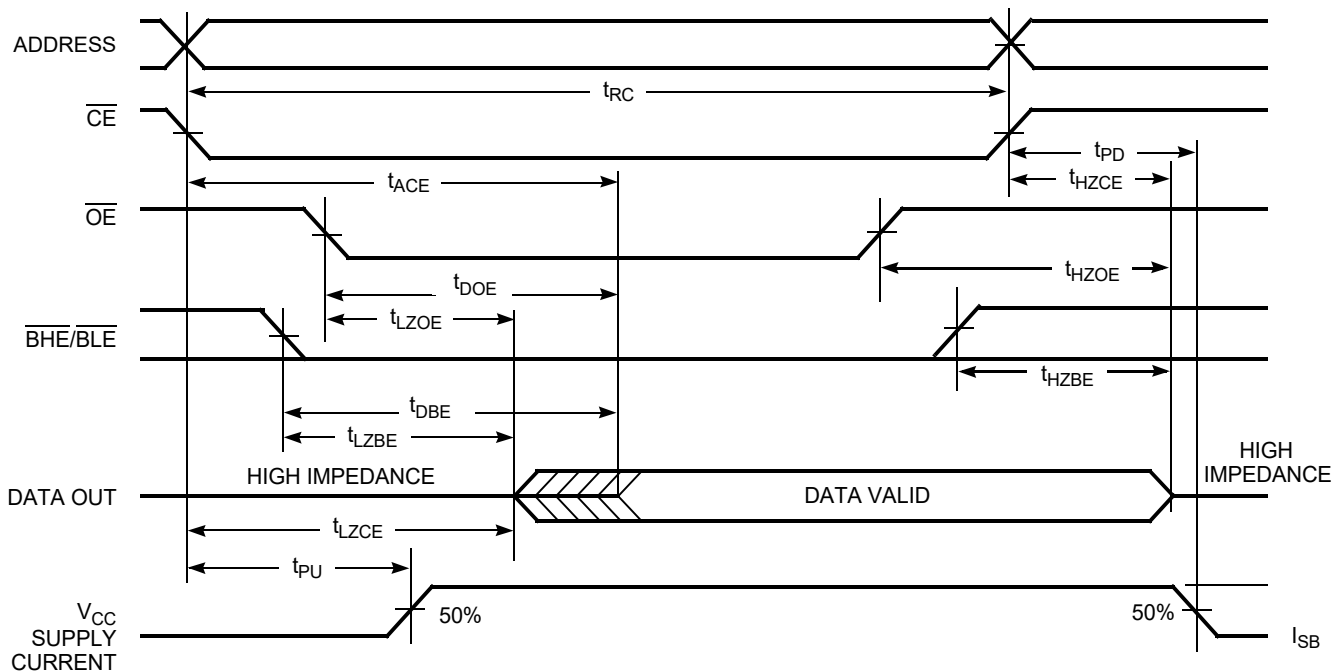

Figure 7. Read Cycle No. 2 ( $\overline{\text{OE}}$  Controlled) [25, 26, 27]



### Notes

24. The device is continuously selected.  $\overline{\text{OE}}$ ,  $\overline{\text{CE}} = V_{\text{IL}}$ ,  $\overline{\text{BHE}}$ ,  $\overline{\text{BLE}}$ , or both =  $V_{\text{IL}}$ .

25.  $\overline{\text{WE}}$  is HIGH for read cycle.

26. BGA packaged device is offered in single CE and dual CE options. In this data sheet, for a dual CE device,  $\overline{\text{CE}}$  refers to the internal logical combination of  $\overline{\text{CE}}_1$  and  $\overline{\text{CE}}_2$  such that when  $\overline{\text{CE}}_1$  is LOW and  $\overline{\text{CE}}_2$  is HIGH,  $\overline{\text{CE}}$  is LOW. For all other cases  $\overline{\text{CE}}$  is HIGH.

27. Address valid before or similar to CE and BHE, BLE transition LOW.

Switching Waveforms (continued)

Figure 8. Write Cycle No. 1 ( $\overline{WE}$  Controlled) [28, 29, 30, 31]

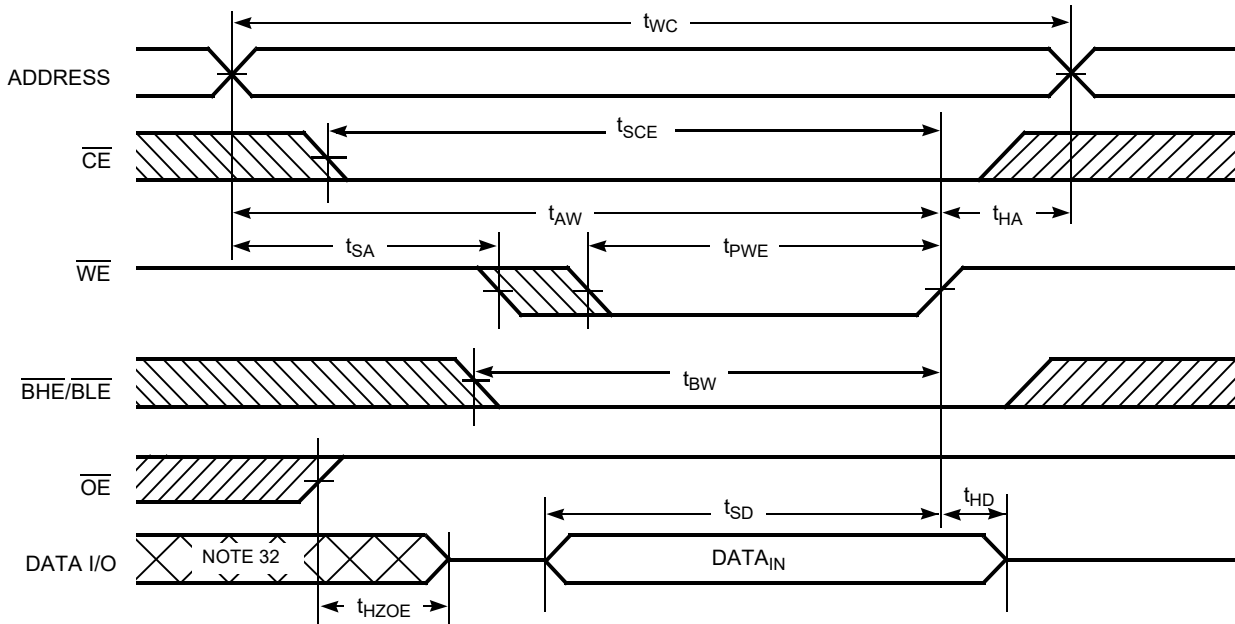
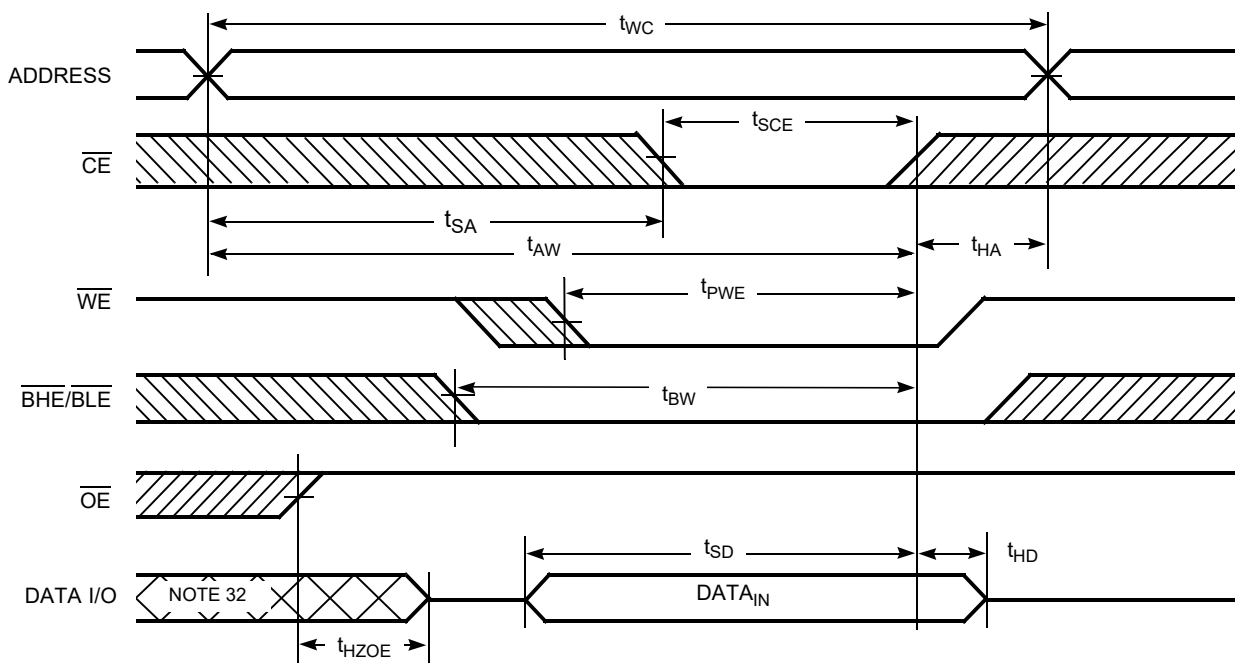

Figure 9. Write Cycle No. 2 ( $\overline{CE}$  Controlled) [28, 29, 30, 31]



Notes

- 28. BGA packaged device is offered in single CE and dual CE options. In this data sheet, for a dual CE device,  $\overline{CE}$  refers to the internal logical combination of  $\overline{CE}_1$  and  $\overline{CE}_2$  such that when  $\overline{CE}_1$  is LOW and  $\overline{CE}_2$  is HIGH,  $\overline{CE}$  is LOW. For all other cases  $\overline{CE}$  is HIGH.
- 29. The internal write time of the memory is defined by the overlap of  $\overline{WE}$ ,  $\overline{CE} = V_{IL}$ ,  $\overline{BHE}$ ,  $\overline{BLE}$ , or both =  $V_{IL}$ . All signals must be active to initiate a write and any of these signals can terminate a write by going inactive. The data input setup and hold timing must be referenced to the edge of the signal that terminates the write.
- 30. Data I/O is high impedance if  $\overline{OE} = V_{IH}$ .
- 31. If  $\overline{CE}$  goes HIGH simultaneously with  $\overline{WE} = V_{IH}$ , the output remains in a high impedance state.
- 32. During this period, the I/Os are in output state. Do not apply input signals.

Switching Waveforms (continued)

Figure 10. Write Cycle No. 3 ( $\overline{WE}$  Controlled,  $\overline{OE}$  LOW) [33, 34, 35]

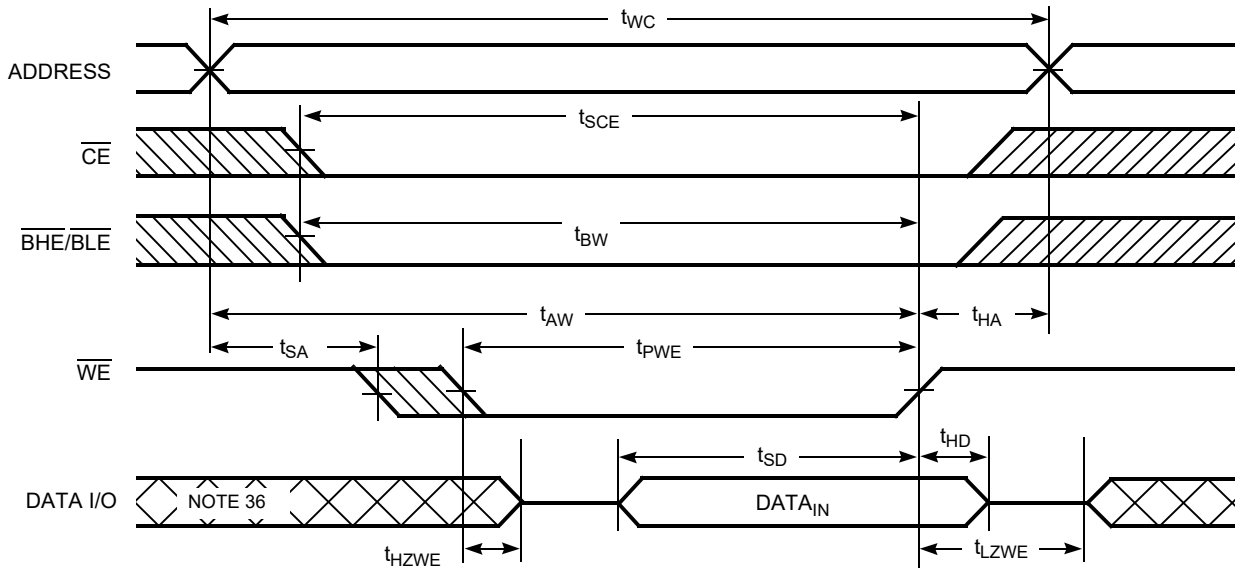
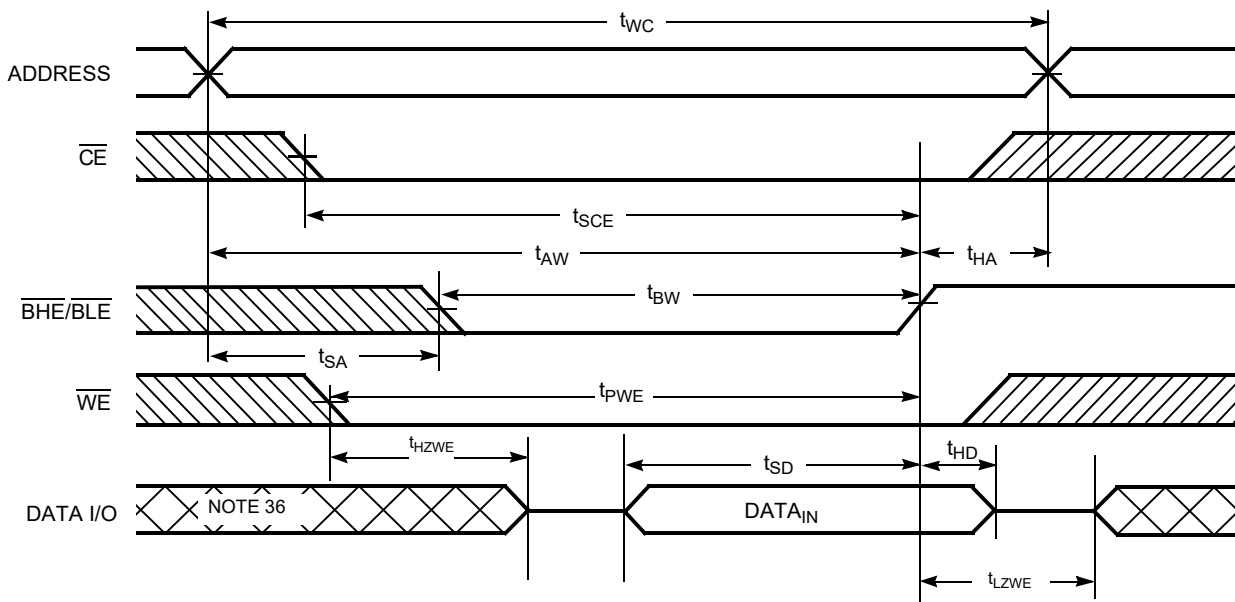

Figure 11. Write Cycle No. 4 ( $\overline{BHE}/\overline{BLE}$  Controlled) [33, 34]



Notes

- 33. BGA packaged device is offered in single CE and dual CE options. In this data sheet, for a dual CE device,  $\overline{CE}$  refers to the internal logical combination of  $\overline{CE}_1$  and  $\overline{CE}_2$  such that when  $\overline{CE}_1$  is LOW and  $\overline{CE}_2$  is HIGH,  $\overline{CE}$  is LOW. For all other cases  $\overline{CE}$  is HIGH.
- 34. If  $\overline{CE}$  goes HIGH simultaneously with  $\overline{WE} = V_{IH}$ , the output remains in a high impedance state.
- 35. The minimum write cycle pulse width should be equal to the sum of  $t_{SD}$  and  $t_{HZWE}$ .
- 36. During this period, the I/Os are in output state. Do not apply input signals.

**Truth Table**

$\overline{CE}$ [37, 38]	$\overline{WE}$	$\overline{OE}$	$\overline{BHE}$	$\overline{BLE}$	I/Os	Mode	Power
H	X	X	X	X	High Z	Deselect/Power-down	Standby ( $I_{SB}$ )
L	X	X	H	H	High Z	Deselect/Power-down	Standby ( $I_{SB}$ )
L	H	L	L	L	Data out (I/O <sub>0</sub> –I/O <sub>15</sub> )	Read	Active ( $I_{CC}$ )
L	H	L	H	L	Data out (I/O <sub>0</sub> –I/O <sub>7</sub> ); I/O <sub>8</sub> –I/O <sub>15</sub> in High Z	Read	Active ( $I_{CC}$ )
L	H	L	L	H	Data out (I/O <sub>8</sub> –I/O <sub>15</sub> ); I/O <sub>0</sub> –I/O <sub>7</sub> in High Z	Read	Active ( $I_{CC}$ )
L	H	H	L	L	High Z	Output disabled	Active ( $I_{CC}$ )
L	H	H	H	L	High Z	Output disabled	Active ( $I_{CC}$ )
L	H	H	L	H	High Z	Output disabled	Active ( $I_{CC}$ )
L	L	X	L	L	Data in (I/O <sub>0</sub> –I/O <sub>15</sub> )	Write	Active ( $I_{CC}$ )
L	L	X	H	L	Data in (I/O <sub>0</sub> –I/O <sub>7</sub> ); I/O <sub>8</sub> –I/O <sub>15</sub> in High Z	Write	Active ( $I_{CC}$ )
L	L	X	L	H	Data in (I/O <sub>8</sub> –I/O <sub>15</sub> ); I/O <sub>0</sub> –I/O <sub>7</sub> in High Z	Write	Active ( $I_{CC}$ )

**Notes**

37. BGA packaged device is offered in single CE and dual CE options. In this data sheet for a dual CE device,  $\overline{CE}$  refers to the internal logical combination of  $\overline{CE}_1$  and  $\overline{CE}_2$  such that when  $\overline{CE}_1$  is LOW and  $\overline{CE}_2$  is HIGH,  $\overline{CE}$  is LOW. For all other cases  $\overline{CE}$  is HIGH.

38. For the Dual Chip Enable device,  $\overline{CE}$  refers to the internal logical combination of  $\overline{CE}_1$  and  $\overline{CE}_2$  such that when  $\overline{CE}_1$  is LOW and  $\overline{CE}_2$  is HIGH,  $\overline{CE}$  is LOW. For all other cases  $\overline{CE}$  is HIGH. Intermediate voltage levels are not permitted on any of the Chip Enable pins (CE for the Single Chip Enable device;  $\overline{CE}_1$  and  $\overline{CE}_2$  for the Dual Chip Enable device).

### Ordering Information

Speed (ns)	Ordering Code	Package Diagram	Package Type	Operating Range
45	CY62147EV30LL-45BVI	51-85150	48-ball VFBGA <sup>[39]</sup>	Industrial
	CY62147EV30LL-45BVXI	51-85150	48-ball VFBGA (Pb-free) <sup>[39]</sup>	
	CY62147EV30LL-45B2XI	51-85150	48-ball VFBGA (Pb-free) <sup>[40]</sup>	
	CY62147EV30LL-45ZSXI	51-85087	44-pin TSOP Type II (Pb-free)	

Contact your local Cypress sales representative for availability of these parts.

### Ordering Code Definitions

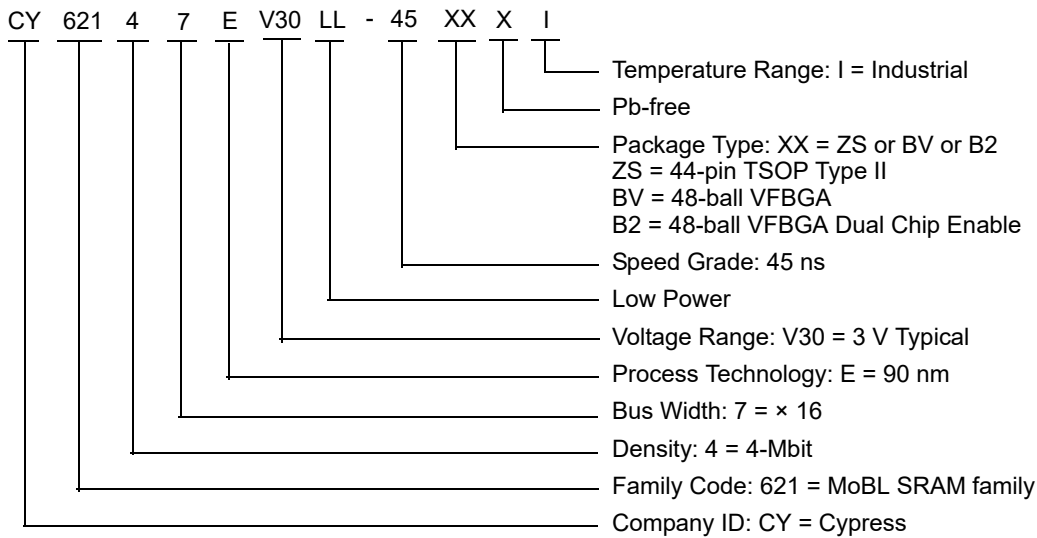

**Notes**

- 39. This BGA package is offered with single chip enable.
- 40. This BGA package is offered with dual chip enable.

Package Diagrams

Figure 12. 48-ball VFBGA (6.0 × 8.0 × 1.0 mm) Package Outline, 51-85150

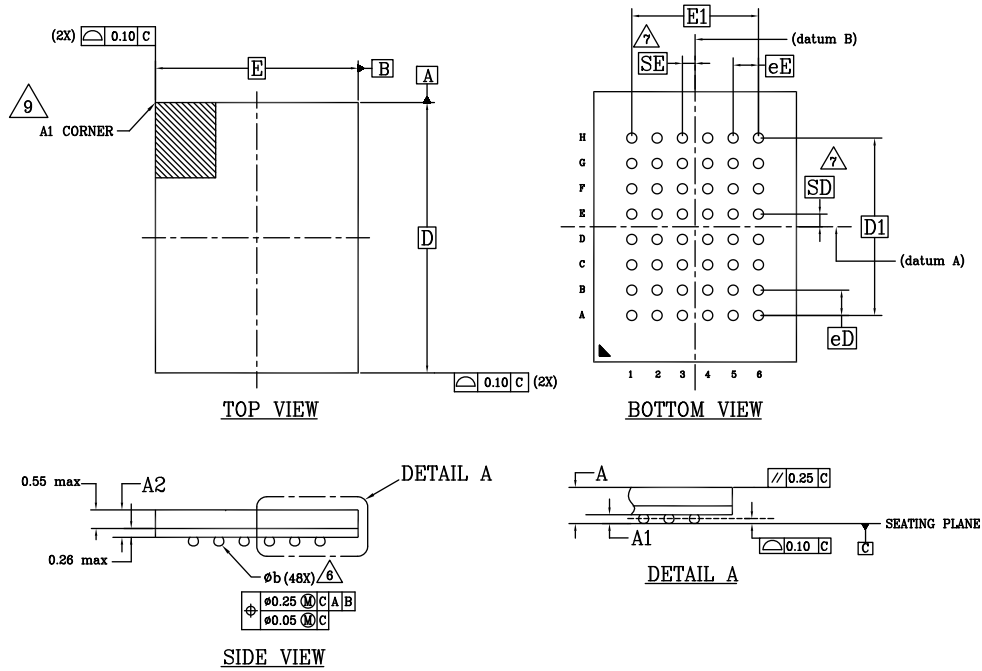

SYMBOL	DIMENSIONS		
	MIN.	NOM.	MAX.
A	-	-	1.00
A1	0.16	-	-
A2	-	-	0.81
D	8.00 BSC		
E	6.00 BSC		
D1	5.25 BSC		
E1	3.75 BSC		
MD	8		
ME	6		
n	48		
∅ b	0.25	0.30	0.35
eE	0.75 BSC		
eD	0.75 BSC		
SD	0.375 BSC		
SE	0.375 BSC		

NOTES:

1. DIMENSIONING AND TOLERANCING METHODS PER ASME Y14.5M-2009.
2. ALL DIMENSIONS ARE IN MILLIMETERS.
3. BALL POSITION DESIGNATION PER JEP95, SECTION 3, SPP-020.
4. [E] REPRESENTS THE SOLDER BALL GRID PITCH.
5. SYMBOL "MD" IS THE BALL MATRIX SIZE IN THE "D" DIRECTION. SYMBOL "ME" IS THE BALL MATRIX SIZE IN THE "E" DIRECTION. n IS THE NUMBER OF POPULATED SOLDER BALL POSITIONS FOR MATRIX SIZE MD X ME.
6. DIMENSION "b" IS MEASURED AT THE MAXIMUM BALL DIAMETER IN A PLANE PARALLEL TO DATUM C.
7. "SD" AND "SE" ARE MEASURED WITH RESPECT TO DATUMS A AND B AND DEFINE THE POSITION OF THE CENTER SOLDER BALL IN THE OUTER ROW. WHEN THERE IS AN ODD NUMBER OF SOLDER BALLS IN THE OUTER ROW "SD" OR "SE" = 0. WHEN THERE IS AN EVEN NUMBER OF SOLDER BALLS IN THE OUTER ROW, "SD" = eD/2 AND "SE" = eE/2.
8. "\*" INDICATES THE THEORETICAL CENTER OF DEPOPULATED BALLS.
9. A1 CORNER TO BE IDENTIFIED BY CHAMFER, LASER OR INK MARK METALIZED MARK, INDENTATION OR OTHER MEANS.

51-85150 \*I

Package Diagrams (continued)

Figure 13. 44-pin TSOP II (18.4 × 10.2 × 1.194 mm) Package Outline, 51-85087

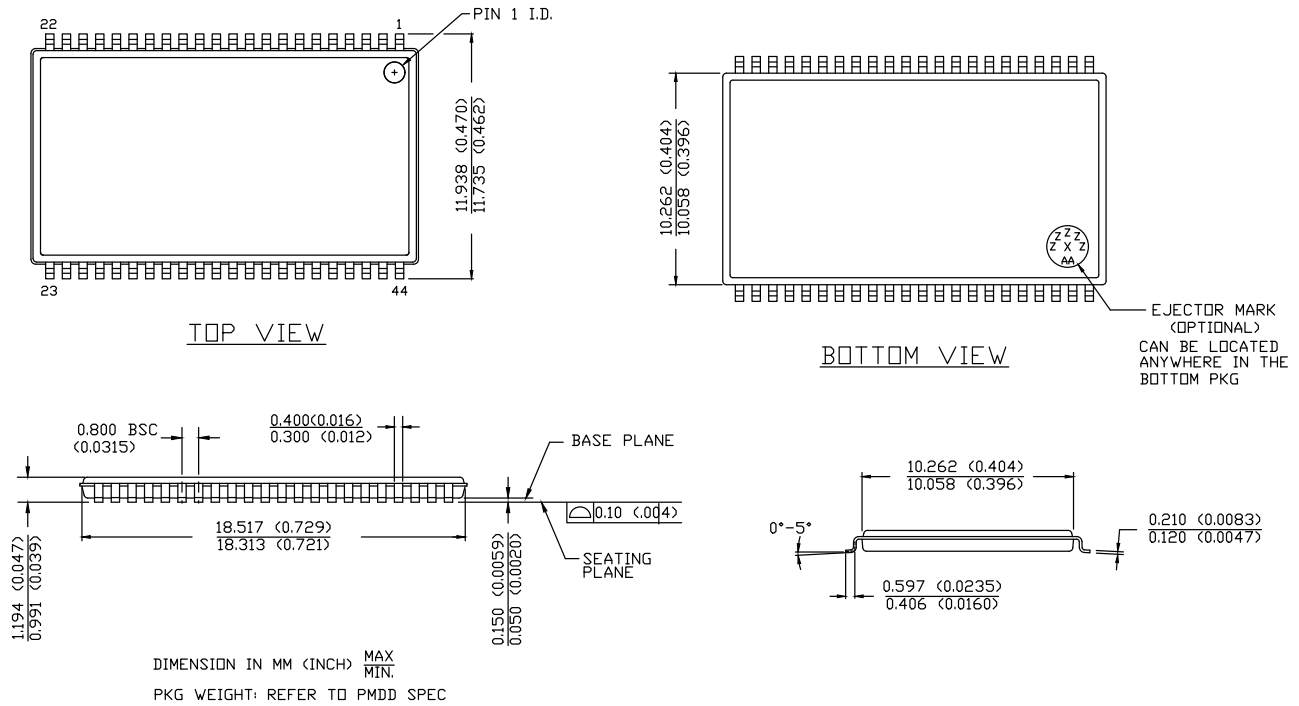

51-85087 \*F

## Acronyms

Acronym	Description
$\overline{\text{BHE}}$	Byte High Enable
$\overline{\text{BLE}}$	Byte Low Enable
$\overline{\text{CE}}$	Chip Enable
CMOS	Complementary Metal Oxide Semiconductor
I/O	Input/Output
$\overline{\text{OE}}$	Output Enable
SRAM	Static Random Access Memory
TSOP	Thin Small Outline Package
VFBGA	Very Fine-Pitch Ball Grid Array
$\overline{\text{WE}}$	Write Enable

## Document Conventions

### Units of Measure

Symbol	Unit of Measure
°C	degree Celsius
MHz	megahertz
μA	microampere
μs	microsecond
mA	milliampere
ns	nanosecond
Ω	ohm
pF	picofarad
V	volt
W	watt

**Document History Page**

Document Title: CY62147EV30 MoBL, 4-Mbit (256K × 16) Static RAM Document Number: 38-05440			
Revision	ECN	Submission Date	Description of Change
**	201861	01/13/2004	New data sheet.
*A	247009	07/27/2004	<p>Changed status from Advanced Information to Preliminary.</p> <p>Updated <a href="#">Operating Range</a>:</p> <p>Updated Note 7 (Replaced 100 μs with 200 μs).</p> <p>Updated <a href="#">Data Retention Characteristics</a>:</p> <p>Changed maximum value of I<sub>CCDR</sub> parameter from 2.0 μA to 2.5 μA.</p> <p>Changed minimum value of t<sub>R</sub> parameter from 100 μs to t<sub>RC</sub> ns.</p> <p>Updated <a href="#">Switching Characteristics</a>:</p> <p>Changed minimum value of t<sub>OHA</sub> parameter from 6 ns to 10 ns corresponding to both 35 ns and 45 ns speed bins.</p> <p>Changed maximum value of t<sub>DOE</sub> parameter from 15 ns to 18 ns corresponding to 35 ns speed bin.</p> <p>Changed maximum value of t<sub>HZOE</sub>, t<sub>HZBE</sub>, t<sub>HZWE</sub> parameters from 12 ns to 15 ns corresponding to 35 ns speed bin and from 15 ns to 18 ns corresponding to 45 ns speed bin.</p> <p>Changed minimum value of t<sub>SCE</sub>, t<sub>BW</sub> parameters from 25 ns to 30 ns corresponding to 35 ns speed bin and from 40 ns to 35 ns corresponding to 45 ns speed bin.</p> <p>Changed maximum value of t<sub>HZCE</sub> parameter from 12 ns to 18 ns corresponding to 35 ns speed bin and from 15 ns to 22 ns corresponding to 45 ns speed bin.</p> <p>Changed minimum value of t<sub>SD</sub> parameter from 15 ns to 18 ns corresponding to 35 ns speed bin and from 20 ns to 22 ns corresponding to 45 ns speed bin.</p> <p>Removed Note "If both Byte Enables (BHE and BLE) are toggled together then this value is 6 ns min. Otherwise this value is 3 ns min." and its reference in t<sub>LZBE</sub> parameter.</p> <p>Updated <a href="#">Ordering Information</a>:</p> <p>Updated part numbers.</p>
*B	414807	12/16/2005	<p>Changed status from Preliminary to Final.</p> <p>Removed 35 ns speed bin related information in all instances across the document.</p> <p>Removed "L" version (of CY62147EV30) related information in all instances across the document.</p> <p>Updated <a href="#">Product Portfolio</a>:</p> <p>Changed typical value of "Operating I<sub>CC</sub>" from 1.5 mA to 2 mA corresponding to "f = 1 MHz".</p> <p>Changed maximum value of "Operating I<sub>CC</sub>" from 2 mA to 2.5 mA corresponding to "f = 1 MHz".</p> <p>Changed typical value of "Operating I<sub>CC</sub>" from 12 mA to 15 mA corresponding to "f = f<sub>max</sub>".</p> <p>Updated <a href="#">Pin Configurations</a>:</p> <p>Updated figure "48-ball VFBGA pinout" (Replaced DNU with NC in ball E3).</p> <p>Removed Note "DNU pins have to be left floating or tied to V<sub>SS</sub> to ensure proper application." and its reference.</p> <p>Updated <a href="#">Electrical Characteristics</a>:</p> <p>Changed typical value of I<sub>CC</sub> parameter from 12 mA to 15 mA corresponding to Test Condition "f = f<sub>max</sub>".</p> <p>Changed typical value of I<sub>CC</sub> parameter from 1.5 mA to 2 mA corresponding to Test Condition "f = 1 MHz".</p> <p>Changed maximum value of I<sub>CC</sub> parameter from 2 mA to 2.5 mA corresponding to Test Condition "f = 1 MHz".</p> <p>Changed typical value of I<sub>SB1</sub>, I<sub>SB2</sub> parameters from 0.7 μA to 1 μA.</p> <p>Changed maximum value of I<sub>SB1</sub>, I<sub>SB2</sub> parameters from 2.5 μA to 7 μA.</p> <p>Updated <a href="#">AC Test Load and Waveforms</a>:</p> <p>Changed AC Test Load Capacitance from 50 pF to 30 pF.</p> <p>Updated <a href="#">Data Retention Characteristics</a>:</p> <p>Added typical value of I<sub>CCDR</sub> parameter.</p> <p>Changed maximum value of I<sub>CCDR</sub> parameter from 2.5 μA to 7 μA.</p>

**Document History Page** (continued)

Document Title: CY62147EV30 MoBL, 4-Mbit (256K × 16) Static RAM Document Number: 38-05440			
Revision	ECN	Submission Date	Description of Change
*B (cont.)	414807	12/16/2005	Updated <a href="#">Switching Characteristics</a> : Changed minimum value of $t_{LZOE}$ parameter from 3 ns to 5 ns. Changed minimum value of $t_{LZCE}$ , $t_{LZBE}$ , $t_{LZWE}$ parameters from 6 ns to 10 ns. Changed maximum value of $t_{HZCE}$ parameter from 22 ns to 18 ns. Changed minimum value of $t_{PWE}$ parameter from 30 ns to 35 ns. Changed minimum value of $t_{SD}$ parameter from 22 ns to 25 ns. Updated <a href="#">Ordering Information</a> : Updated part numbers. Removed "Package Name" column. Added "Package Diagram" column. Updated <a href="#">Package Diagrams</a> : spec 51-85150 – Changed revision from *B to *D. Updated to new template.
*C	464503	05/25/2006	Added Automotive-E Temperature Range related information in all instances across the document and assigned Preliminary status (shaded the area) in required places. Added 55 ns speed bin related information in all instances across the document. Updated <a href="#">Ordering Information</a> : Updated part numbers.
*D	925501	04/09/2007	Added Automotive-A Temperature Range related information in all instances across the document and assigned Preliminary status (shaded the area) in required places. Updated <a href="#">Electrical Characteristics</a> : Added Note 9 and referred the same note in $I_{SB2}$ parameter. Updated <a href="#">Data Retention Characteristics</a> : Added Note 12 and referred the same note in $I_{CCDR}$ parameter. Updated <a href="#">Switching Characteristics</a> : Added Note 18 and referred the same note in "Parameter" column.
*E	1045701	05/07/2007	Changed status of Automotive-A and Automotive-E Temperature Range related information from Preliminary to Final (unshaded the area).
*F	2577505	10/03/2008	Updated <a href="#">Ordering Information</a> : Updated part numbers. Updated to new template.
*G	2681901	04/01/2009	Updated <a href="#">Ordering Information</a> : Updated part numbers.
*H	2886488	03/02/2010	Updated <a href="#">Truth Table</a> : Added Note 38 and referred the same note in "CE" column. Updated <a href="#">Package Diagrams</a> : spec 51-85150 – Changed revision from *D to *E. spec 51-85087 – Changed revision from *A to *C. Updated to new template.
*I	3109050	12/13/2010	Changed Table Footnotes to Notes in all instances across the document. Updated <a href="#">Ordering Information</a> : No change in part numbers. Added <a href="#">Ordering Code Definitions</a> . Updated <a href="#">Package Diagrams</a> : spec 51-85150 – Changed revision from *E to *F.
*J	3123973	01/31/2011	Removed Automotive-A and Automotive-E Temperature Range related information in all instances across the document. Updated <a href="#">Ordering Information</a> : Updated part numbers. Added <a href="#">Acronyms</a> and <a href="#">Units of Measure</a> .

Document History Page (continued)

Document Title: CY62147EV30 MoBL, 4-Mbit (256K × 16) Static RAM Document Number: 38-05440			
Revision	ECN	Submission Date	Description of Change
*K	3296744	08/09/2011	Updated <a href="#">Functional Description</a> : Updated description. Updated <a href="#">Electrical Characteristics</a> : Updated Note 9. Referred Note 9 in I <sub>SB1</sub> parameter. Updated <a href="#">Data Retention Characteristics</a> : Updated Note 12. Updated <a href="#">Switching Characteristics</a> : Added Note 21 and referred the same note in the description of t <sub>LZBE</sub> parameter. Completing Sunset Review.
*L	3456837	12/06/2011	Updated <a href="#">Package Diagrams</a> : spec 51-85150 – Changed revision from *F to *G. spec 51-85087 – Changed revision from *C to *D. Updated to new template.
*M	3724736	08/23/2012	Fixed typo errors. Minor clean-up. Completing Sunset Review.
*N	4102445	08/22/2013	Updated <a href="#">Switching Characteristics</a> : Updated Note 18. Updated <a href="#">Package Diagrams</a> : spec 51-85150 – Changed revision from *G to *H. spec 51-85087 – Changed revision from *D to *E. Updated to new template. Completing Sunset Review.
*O	4576526	11/21/2014	Updated <a href="#">Functional Description</a> : Added "For a complete list of related documentation, <a href="#">click here</a> ." at the end. Updated <a href="#">Switching Characteristics</a> : Added Note 23 and referred the same note in "Write Cycle". Updated <a href="#">Switching Waveforms</a> : Added Note 35 and referred the same note in <a href="#">Figure 10</a> .
*P	4918858	09/14/2015	Updated <a href="#">Switching Waveforms</a> : Updated <a href="#">Figure 11</a> (Updated caption only (Removed "OE LOW")). Updated to new template. Completing Sunset Review.
*Q	5445135	09/22/2016	Updated <a href="#">Thermal Resistance</a> : Updated values of $\Theta_{JA}$ and $\Theta_{JC}$ parameters corresponding to all packages. Updated to new template. Completing Sunset Review.
*R	5984537	12/05/2017	Updated Cypress Logo and Copyright.
*S	6548255	04/17/2019	Updated <a href="#">Package Diagrams</a> : spec 51-85150 – Changed revision from *H to *I. Updated to new template.
*T	6899706	06/26/2020	Updated <a href="#">Features</a> : Changed value of "Typical standby current" from 1 $\mu$ A to 2.5 $\mu$ A. Changed value of "Typical active current" from 2 mA to 3.5 mA. Updated <a href="#">Product Portfolio</a> : Changed typical value of "Operating I <sub>CC</sub> " from 2 mA to 3.5 mA corresponding to "f = 1 MHz". Changed maximum value of "Operating I <sub>CC</sub> " from 2.5 mA to 6 mA corresponding to "f = 1 MHz". Changed typical value of "Standby I <sub>SB2</sub> " from 1 $\mu$ A to 2.5 $\mu$ A.

**Document History Page** (continued)

Document Title: CY62147EV30 MoBL, 4-Mbit (256K × 16) Static RAM			
Document Number: 38-05440			
Revision	ECN	Submission Date	Description of Change
*T (cont.)	6899706	06/26/2020	<p>Updated <a href="#">Electrical Characteristics</a>:</p> <p>Changed typical value of I<sub>CC</sub> parameter from 2 mA to 3.5 mA corresponding to Test Condition "f = 1 MHz".</p> <p>Changed maximum value of I<sub>CC</sub> parameter from 2.5 mA to 6 mA corresponding to Test Condition "f = 1 MHz".</p> <p>Changed typical value of I<sub>SB1</sub> parameter from 1 μA to 2.5 μA.</p> <p>Changed typical value of I<sub>SB2</sub> parameter from 1 μA to 2.5 μA.</p> <p>Updated <a href="#">Data Retention Characteristics</a>:</p> <p>Changed typical value of I<sub>CCDR</sub> parameter from 0.8 μA to 3 μA.</p> <p>Changed maximum value of I<sub>CCDR</sub> parameter from 7 μA to 8.8 μA.</p> <p>Updated <a href="#">Package Diagrams</a>:</p> <p>spec 51-85087 – Changed revision from *E to *F.</p> <p>Updated to new template.</p>

## Sales, Solutions, and Legal Information

### Worldwide Sales and Design Support

Cypress maintains a worldwide network of offices, solution centers, manufacturer's representatives, and distributors. To find the office closest to you, visit us at [Cypress Locations](#).

#### Products

Arm® Cortex® Microcontrollers	<a href="http://cypress.com/arm">cypress.com/arm</a>
Automotive	<a href="http://cypress.com/automotive">cypress.com/automotive</a>
Clocks & Buffers	<a href="http://cypress.com/clocks">cypress.com/clocks</a>
Interface	<a href="http://cypress.com/interface">cypress.com/interface</a>
Internet of Things	<a href="http://cypress.com/iot">cypress.com/iot</a>
Memory	<a href="http://cypress.com/memory">cypress.com/memory</a>
Microcontrollers	<a href="http://cypress.com/mcu">cypress.com/mcu</a>
PSoC	<a href="http://cypress.com/psoc">cypress.com/psoc</a>
Power Management ICs	<a href="http://cypress.com/pmic">cypress.com/pmic</a>
Touch Sensing	<a href="http://cypress.com/touch">cypress.com/touch</a>
USB Controllers	<a href="http://cypress.com/usb">cypress.com/usb</a>
Wireless Connectivity	<a href="http://cypress.com/wireless">cypress.com/wireless</a>

#### PSoC® Solutions

[PSoC 1](#) | [PSoC 3](#) | [PSoC 4](#) | [PSoC 5LP](#) | [PSoC 6 MCU](#)

#### Cypress Developer Community

[Community](#) | [Code Examples](#) | [Projects](#) | [Video](#) | [Blogs](#) | [Training](#) | [Components](#)

#### Technical Support

[cypress.com/support](http://cypress.com/support)

© Cypress Semiconductor Corporation, 2004–2020. This document is the property of Cypress Semiconductor Corporation and its subsidiaries ("Cypress"). This document, including any software or firmware included or referenced in this document ("Software"), is owned by Cypress under the intellectual property laws and treaties of the United States and other countries worldwide. Cypress reserves all rights under such laws and treaties and does not, except as specifically stated in this paragraph, grant any license under its patents, copyrights, trademarks, or other intellectual property rights. If the Software is not accompanied by a license agreement and you do not otherwise have a written agreement with Cypress governing the use of the Software, then Cypress hereby grants you a personal, non-exclusive, nontransferable license (without the right to sublicense) (1) under its copyright rights in the Software (a) for Software provided in source code form, to modify and reproduce the Software solely for use with Cypress hardware products, only internally within your organization, and (b) to distribute the Software in binary code form externally to end users (either directly or indirectly through resellers and distributors), solely for use on Cypress hardware product units, and (2) under those claims of Cypress's patents that are infringed by the Software (as provided by Cypress, unmodified) to make, use, distribute, and import the Software solely for use with Cypress hardware products. Any other use, reproduction, modification, translation, or compilation of the Software is prohibited.

TO THE EXTENT PERMITTED BY APPLICABLE LAW, CYPRESS MAKES NO WARRANTY OF ANY KIND, EXPRESS OR IMPLIED, WITH REGARD TO THIS DOCUMENT OR ANY SOFTWARE OR ACCOMPANYING HARDWARE, INCLUDING, BUT NOT LIMITED TO, THE IMPLIED WARRANTIES OF MERCHANTABILITY AND FITNESS FOR A PARTICULAR PURPOSE. No computing device can be absolutely secure. Therefore, despite security measures implemented in Cypress hardware or software products, Cypress shall have no liability arising out of any security breach, such as unauthorized access to or use of a Cypress product. CYPRESS DOES NOT REPRESENT, WARRANT, OR GUARANTEE THAT CYPRESS PRODUCTS, OR SYSTEMS CREATED USING CYPRESS PRODUCTS, WILL BE FREE FROM CORRUPTION, ATTACK, VIRUSES, INTERFERENCE, HACKING, DATA LOSS OR THEFT, OR OTHER SECURITY INTRUSION (collectively, "Security Breach"). Cypress disclaims any liability relating to any Security Breach, and you shall and hereby do release Cypress from any claim, damage, or other liability arising from any Security Breach. In addition, the products described in these materials may contain design defects or errors known as errata which may cause the product to deviate from published specifications. To the extent permitted by applicable law, Cypress reserves the right to make changes to this document without further notice. Cypress does not assume any liability arising out of the application or use of any product or circuit described in this document. Any information provided in this document, including any sample design information or programming code, is provided only for reference purposes. It is the responsibility of the user of this document to properly design, program, and test the functionality and safety of any application made of this information and any resulting product. "High-Risk Device" means any device or system whose failure could cause personal injury, death, or property damage. Examples of High-Risk Devices are weapons, nuclear installations, surgical implants, and other medical devices. "Critical Component" means any component of a High-Risk Device whose failure to perform can be reasonably expected to cause, directly or indirectly, the failure of the High-Risk Device, or to affect its safety or effectiveness. Cypress is not liable, in whole or in part, and you shall and hereby do release Cypress from any claim, damage, or other liability arising from any use of a Cypress product as a Critical Component in a High-Risk Device. You shall indemnify and hold Cypress, its directors, officers, employees, agents, affiliates, distributors, and assigns harmless from and against all claims, costs, damages, and expenses, arising out of any claim, including claims for product liability, personal injury or death, or property damage arising from any use of a Cypress product as a Critical Component in a High-Risk Device. Cypress products are not intended or authorized for use as a Critical Component in any High-Risk Device except to the limited extent that (i) Cypress's published data sheet for the product explicitly states Cypress has qualified the product for use in a specific High-Risk Device, or (ii) Cypress has given you advance written authorization to use the product as a Critical Component in the specific High-Risk Device and you have signed a separate indemnification agreement.

Cypress, the Cypress logo, Spansion, the Spansion logo, and combinations thereof, WICED, PSoC, CapSense, EZ-USB, F-RAM, and Traveo are trademarks or registered trademarks of Cypress in the United States and other countries. For a more complete list of Cypress trademarks, visit [cypress.com](http://cypress.com). Other names and brands may be claimed as property of their respective owners.

## Looking for pricing, stock, or lifecycle information?

Click below to explore more details on WIN SOURCE:

 [View CY62147EV30LL-45BVI on WIN SOURCE](#)

 [Infineon Technologies](#) Information

## Optimize Your Supply Chain with WIN SOURCE Solutions

-  Global Sourcing Solution
-  Obsolete Management
-  Cost Control Management
-  Shortage Management
-  Alternative Solution
-  Excess Inventory Management