



THE DATASHEET OF CDCVF310PWRG4



2.5-V TO 3.3-V HIGH-PERFORMANCE CLOCK BUFFER

FEATURES

- High-Performance 1:10 Clock Driver
- Pin-to-Pin Skew < 100 ps at V_{DD} 3.3 V
- V_{DD} Range = 2.3 V to 3.6 V
- Input Clock Up To 200 MHz (See [Figure 7](#))
- Operating Temperature Range -40°C to 85°C
- Output Enable Glitch Suppression
- Distributes One Clock Input to Two Banks of Five Outputs
- Packaged in 24-Pin TSSOP
- Pin-to-Pin Compatible to the CDCVF2310, Except the $R = 22\text{-}\Omega$ Series Damping Resistors at Y_n

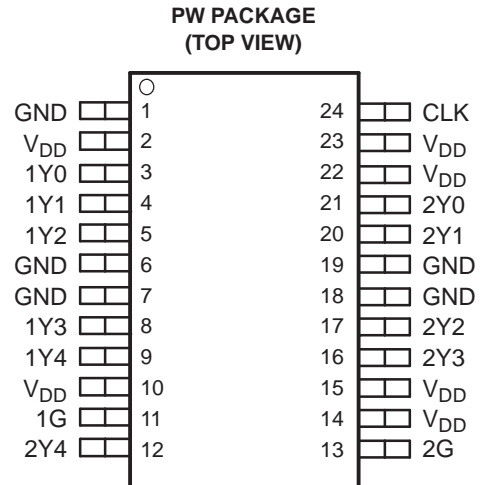

APPLICATIONS

- General-Purpose Applications

DESCRIPTION

The CDCVF310 is a high-performance, low-skew clock buffer that operates up to 200 MHz. Two banks of five outputs each provide low-skew copies of CLK. After power up, the default state of the outputs is low regardless of the state of the control pins. For normal operation, the outputs of bank 1Y[0:4] or 2Y[0:4] can be placed in a low state when the control pins (1G or 2G, respectively) are held low and a negative clock edge is detected on the CLK input. The outputs of bank 1Y[0:4] or 2Y[0:4] can be switched into the buffer mode when the control pins (1G and 2G) are held high and a negative clock edge is detected on the CLK input. The device operates in a 2.5-V and 3.3-V environment. The built-in output enable glitch suppression ensures a synchronized output enable sequence to distribute full period clock signals.

The CDCVF310 is characterized for operation from -40°C to 85°C .



Please be aware that an important notice concerning availability, standard warranty, and use in critical applications of Texas Instruments semiconductor products and disclaimers thereto appears at the end of this data sheet.



These devices have limited built-in ESD protection. The leads should be shorted together or the device placed in conductive foam during storage or handling to prevent electrostatic damage to the MOS gates.

FUNCTIONAL BLOCK DIAGRAM

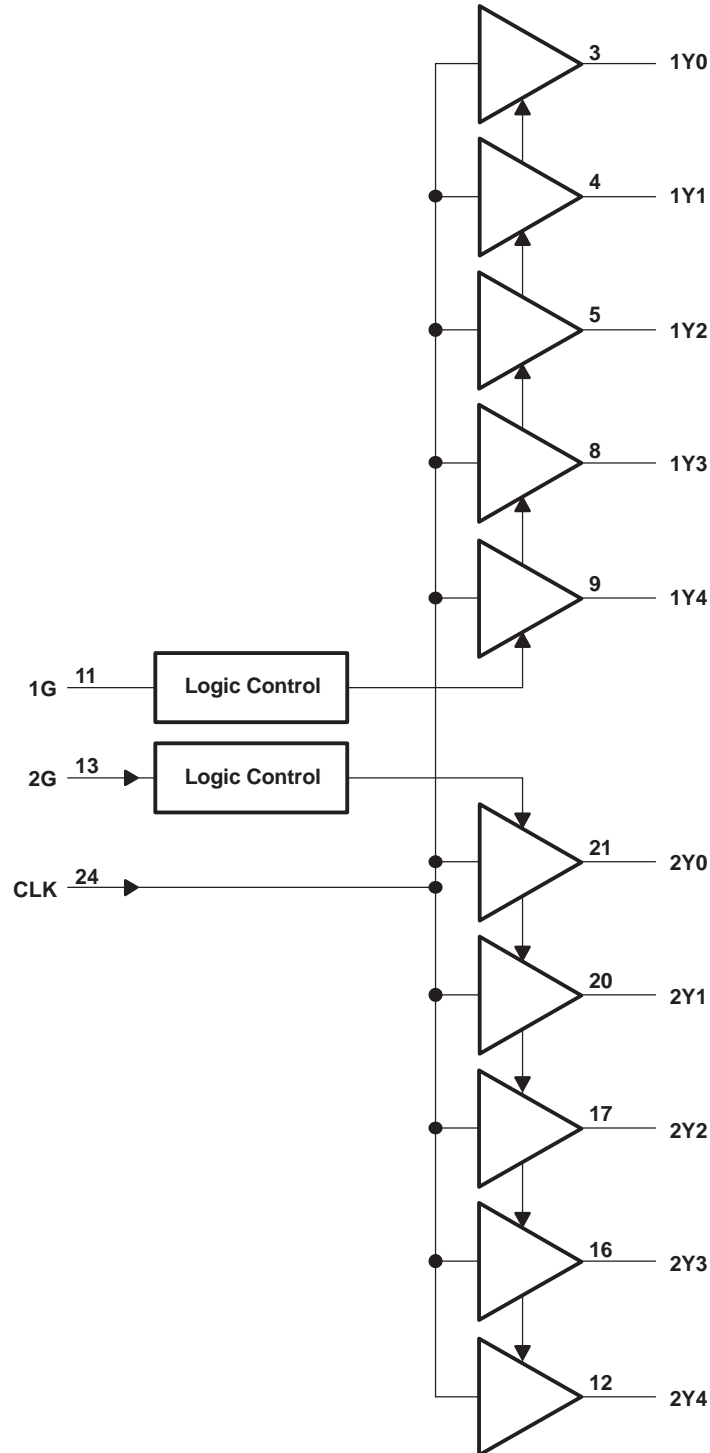

FUNCTION TABLE

INPUT			OUTPUT	
1G	2G	CLK	1Y[0:4]	2Y[0:4]
L	L	↓	L	L
H	L	↓	CLK ⁽¹⁾	L
L	H	↓	L	CLK ⁽¹⁾
H	H	↓	CLK ⁽¹⁾	CLK ⁽¹⁾

- (1) After detecting one negative edge on the CLK input, the output follows the input CLK if the control pin is held high.

Terminal Functions

TERMINAL		I/O	DESCRIPTION
NAME	NO.		
1G	11	I	Output enable control for 1Y[0:4] outputs. This output enable is active-high, meaning the 1Y[0:4] clock outputs follow the input clock (CLK) if this pin is logic high.
2G	13	I	Output enable control for 2Y[0:4] outputs. This output enable is active-high, meaning the 2Y[0:4] clock outputs follow the input clock (CLK) if this pin is logic high.
1Y[0:4]	3, 4, 5, 8, 9	O	Buffered output clocks
2Y[0:4]	21, 20, 17, 16, 12	O	Buffered output clocks
CLK	24	I	Input reference frequency
GND	1, 6, 7, 18, 19		Ground
V _{DD}	2, 10, 14, 15, 22, 23		DC power supply, 2.3 V – 3.6 V

DETAILED DESCRIPTION

Output Enable Glitch Suppression Circuit

The purpose of the glitch suppression circuitry is to ensure the output enable sequence is synchronized with the clock input such that the output buffer is enabled or disabled on the next full period of the input clock (negative edge triggered by the input clock) (see Figure 1).

The G input must fulfill the timing requirements (t_{su} , t_h) according to the *Switching Characteristics* table for predictable operation.

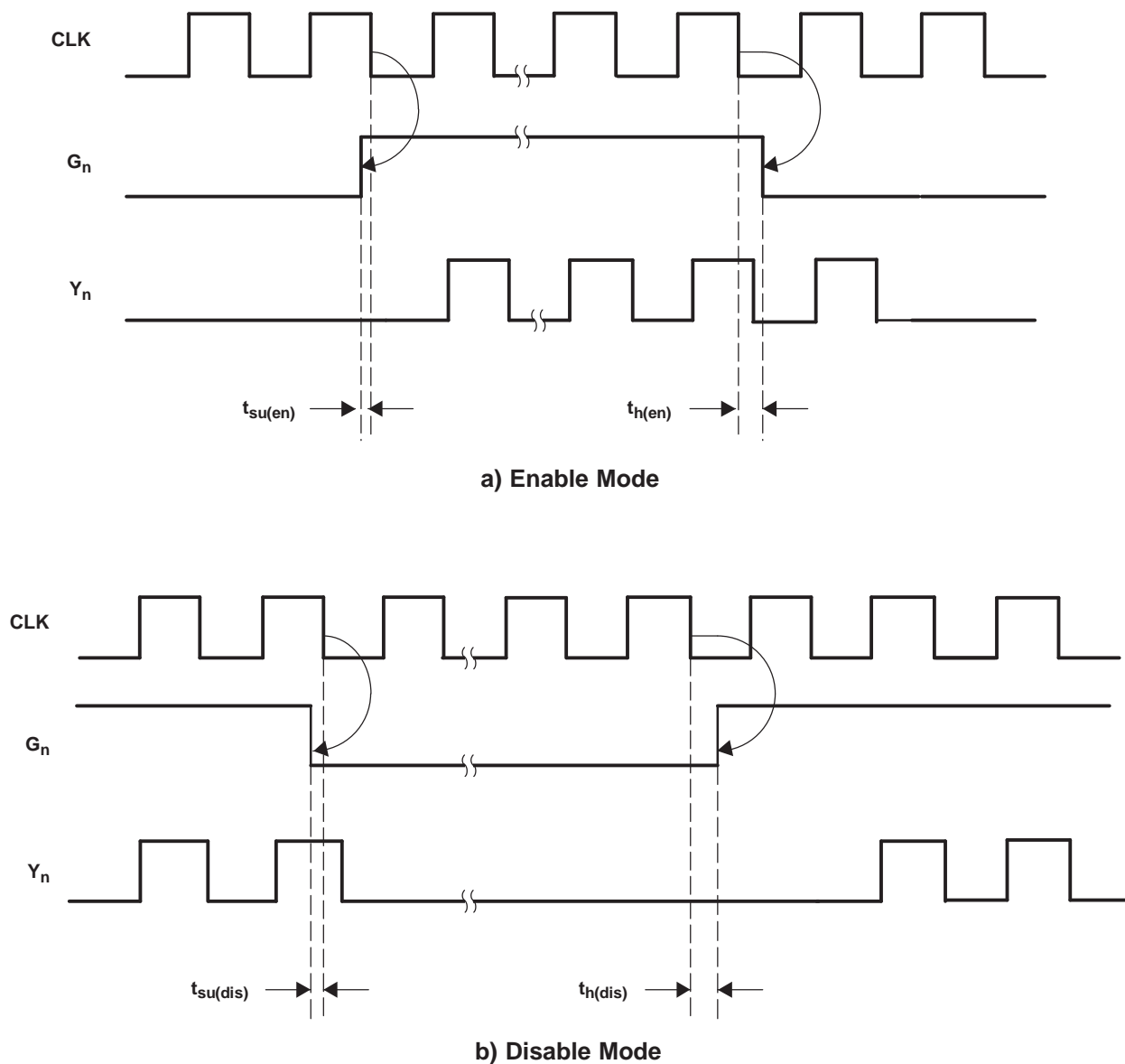

Figure 1. Enable and Disable Mode Relative to CLK↓

ABSOLUTE MAXIMUM RATINGS

over operating free-air temperature range (unless otherwise noted) ⁽¹⁾

Supply voltage range, V_{DD}	–0.5 V to 4.6 V
Input voltage range, V_I ⁽²⁾⁽³⁾	–0.5 V to $V_{DD} + 0.5$ V
Output voltage range, V_O ⁽²⁾⁽³⁾	–0.5 V to $V_{DD} + 0.5$ V
Input clamp current, I_{IK} ($V_I < 0$ or $V_I > V_{DD}$)	±50 mA
Output clamp current, I_{OK} ($V_O < 0$ or $V_O > V_{DD}$)	±50 mA
Continuous total output current, I_O ($V_O = 0$ to V_{DD})	±50 mA
Package thermal impedance, θ_{JA} ⁽⁴⁾ : PW package	88°C/W, high K
	120°C/W, low K
Storage temperature range T_{stg}	–65°C to 150°C

- (1) Stresses beyond those listed under “absolute maximum ratings” may cause permanent damage to the device. These are stress ratings only, and functional operation of the device at these or any other conditions beyond those indicated under “recommended operating conditions” is not implied. Exposure to absolute-maximum-rated conditions for extended periods may affect device reliability.
- (2) The input and output negative voltage ratings may be exceeded if the input and output clamp-current ratings are observed.
- (3) This value is limited to 4.6 V maximum.
- (4) The package thermal impedance is calculated in accordance with JESD 51.

RECOMMENDED OPERATING CONDITIONS ⁽¹⁾

		MIN	NOM	MAX	UNIT
Supply voltage, V_{DD}		2.3	2.5		V
			3.3	3.6	
Low-level input voltage, V_{IL}	$V_{DD} = 3$ V to 3.6 V			0.8	V
	$V_{DD} = 2.3$ V to 2.7 V			0.7	
High-level input voltage, V_{IH}	$V_{DD} = 3$ V to 3.6 V	2			V
	$V_{DD} = 2.3$ V to 2.7 V	1.7			
Input voltage, V_I		0		V_{DD}	V
High-level output current, I_{OH}	$V_{DD} = 3$ V to 3.6 V			–12	mA
	$V_{DD} = 2.3$ V to 2.7 V			–6	
Low-level output current, I_{OL}	$V_{DD} = 3$ V to 3.6 V			12	mA
	$V_{DD} = 2.3$ V to 2.7 V			6	
Operating free-air temperature, T_A		–40		85	°C

- (1) Unused inputs must be held high or low to prevent them from floating.

TIMING REQUIREMENTS

over operating free-air temperature range (unless otherwise noted)

PARAMETER		TEST CONDITIONS	MIN	TYP	MAX	UNIT
f_{clk}	Clock frequency	$V_{DD} = 2.3$ V to 3.6 V, See Figure 7	0		200	MHz

ELECTRICAL CHARACTERISTICSover recommended operating free-air temperature range (unless otherwise noted)⁽¹⁾

PARAMETER		TEST CONDITIONS	MIN	TYP	MAX	UNIT
V _{IK}	Input voltage	V _{DD} = 3 V, I _I = -18 mA			-1.2	V
I _I	Input current	V _I = 0 V or V _{DD}			±5	μA
I _{DD} ⁽²⁾	Static device current	CLK = 0 V or V _{DD} = 3.6 V, I _O = 0 mA			80	μA
C _I	Input capacitance	V _{DD} = 2.3 V to 3.6 V, V _I = 0 V or V _{DD}		2.5		pF
C _O	Output capacitance	V _{DD} = 2.3 V to 3.6 V, V _I = 0 V or V _{DD}		2.6		pF
C _{PD}	Power dissipation ⁽³⁾	V _{DD} = 2.3 V to 3.6 V, V _I = 0 V or V _{DD}			32	pF

(1) All typical values are with respect to nominal V_{DD}.(2) For dynamic I_{DD} over Frequency see Figure 6.

(3) This is the formula for the power dissipation calculation.

$$P_{\text{tot}} = P_{\text{stat}} + P_{\text{Dyn}} + P_{\text{Load}}[\text{W}]$$

$$P_{\text{stat}} = V_{\text{DD}} \times I_{\text{DD}} [\text{W}]$$

$$P_{\text{Dyn}} = C_{\text{PD}} \times V_{\text{DD}} \times V_{\text{DD}} \times f [\text{W}]$$

$$P_{\text{Load}} = C_{\text{Load}} \times V_{\text{DD}} \times V_{\text{DD}} \times f \times n [\text{W}]$$

n = Number of switching output pins

V_{DD} = 3.3 V ±0.3 V

PARAMETER		TEST CONDITIONS	MIN	TYP ⁽¹⁾	MAX	UNIT
V _{OH}	High-level output voltage	V _{DD} = min to max, I _{OH} = -100 μA	V _{DD} - 0.2			V
		V _{DD} = 3 V	I _{OH} = -12 mA	2.1		
			I _{OH} = -6 mA	2.4		
V _{OL}	Low-level output voltage	V _{DD} = min to max, I _{OL} = 100 μA			0.2	V
		V _{DD} = 3 V	I _{OL} = 12 mA	0.4		
			I _{OL} = 6 mA	0.3		
I _{OH}	High-level output current	V _{DD} = 3 V, V _O = 1 V	-37			mA
		V _{DD} = 3.3 V, V _O = 1.65 V			-57	
		V _{DD} = 3.6 V, V _O = 3.135 V			-38	
I _{OL}	Low-level output current	V _{DD} = 3 V, V _O = 1.95 V	37			mA
		V _{DD} = 3.3 V, V _O = 1.65 V			57	
		V _{DD} = 3.6 V, V _O = 0.4 V			38	

(1) All typical values are with respect to nominal V_{DD}.**V_{DD} = 2.5 V ±0.2 V**

PARAMETER		TEST CONDITIONS	MIN	TYP ⁽¹⁾	MAX	UNIT
V _{OH}	High-level output voltage	V _{DD} = min to max, I _{OH} = -100 A	V _{DD} - 0.2			V
		V _{DD} = 2.3 V, I _{OH} = -6 mA	1.8			
V _{OL}	Low-level output voltage	V _{DD} = min to max, I _{OL} = 100 A			0.2	V
		V _{DD} = 2.3 V, I _{OL} = 6 mA			0.4	
I _{OH}	High-level output current	V _{DD} = 2.3 V, V _O = 1 V	-20			mA
		V _{DD} = 2.5 V, V _O = 1.25 V			-36	
		V _{DD} = 2.7 V, V _O = 2.375 V			-25	
I _{OL}	Low-level output current	V _{DD} = 2.3 V, V _O = 1.2 V	20			mA
		V _{DD} = 2.5 V, V _O = 1.25 V			36	
		V _{DD} = 2.7 V, V _O = 0.3 V			25	

(1) All typical values are with respect to nominal V_{DD}.

JITTER CHARACTERISTICS

Characterized using CDCVF310 Performance EVM when $V_{DD}=3.3$ V. Outputs not under test are terminated to 50 Ω .

PARAMETER	TEST CONDITIONS	MIN	TYP	MAX	UNIT
t_{jitter} Additive phase jitter from input to output 1Y0	12 kHz to 5 MHz, $f_{\text{out}} = 30.72$ MHz		47		fs rms
	12 kHz to 20 MHz, $f_{\text{out}} = 125$ MHz		40		

SWITCHING CHARACTERISTICS

over recommended operating free-air temperature range (unless otherwise noted)

PARAMETER	TEST CONDITIONS	MIN	TYP ⁽¹⁾	MAX	UNIT
$V_{DD} = 3.3$ V ± 0.3 V (see Figure 2)					
t_{PLH}	CLK to Yn $f = 0$ MHz to 200 MHz	1		2.8	ns
t_{PHL}		1		2.8	
$t_{\text{sk(o)}}$	Output skew (Ym to Yn) ⁽²⁾ (see Figure 4)		100	150	ps
$t_{\text{sk(p)}}$	Pulse skew (see Figure 5)			250	ps
$t_{\text{sk(pp)}}$	Part-to-part skew			350	ps
t_r	Rise time $V_O = 0.4$ V to 2 V	1.3		2.7	V/ns
t_f	Fall time $V_O = 2$ V to 0.4 V	1.3		2.7	V/ns
$t_{\text{su(en)}}$	Enable setup time, G_high before CLK \downarrow	0.1			ns
$t_{\text{su(dis)}}$	Disable setup time, G_low before CLK \downarrow	0.1			ns
$t_{\text{h(en)}}$	Enable hold time, G_high after CLK \downarrow	0.4			ns
$t_{\text{h(dis)}}$	Disable hold time, G_low after CLK \downarrow	0.4			ns
$V_{DD} = 2.5$ V ± 0.2 V (see Figure 2)					
t_{PLH}	CLK to Yn $f = 0$ MHz to 200 MHz	1.3		4	ns
t_{PHL}		1.3		4	
$t_{\text{sk(o)}}$	Output skew (Ym to Yn) ⁽²⁾ (see Figure 4)		150	230	ps
$t_{\text{sk(p)}}$	Pulse skew (see Figure 5)			280	ps
$t_{\text{sk(pp)}}$	Part-to-part skew			400	ps
t_r	Rise time $V_O = 0.4$ V to 1.7 V	0.5		1.6	V/ns
t_f	Fall time $V_O = 1.7$ V to 0.4 V	0.5		1.6	V/ns
$t_{\text{su(en)}}$	Enable setup time, G_high before CLK \downarrow	0.1			ns
$t_{\text{su(dis)}}$	Disable setup time, G_low before CLK \downarrow	0.1			ns
$t_{\text{h(en)}}$	Enable hold time, G_high after CLK \downarrow	0.4			ns
$t_{\text{h(dis)}}$	Disable hold time, G_low after CLK \downarrow	0.4			ns

(1) All typical values are with respect to nominal V_{DD} .

(2) The $t_{\text{sk(o)}}$ specification is only valid for equal loading of all outputs.

PARAMETER MEASUREMENT INFORMATION

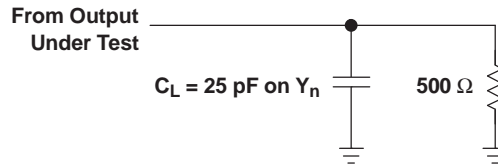

- A. C_L includes probe and jig capacitance.
- B. All input pulses are supplied by generators having the following characteristics: Clock Frequency $\leq 200 \text{ MHz}$, $Z_O = 50 \Omega$, $t_r < 1.2 \text{ ns}$, $t_f < 1.2 \text{ ns}$.

Figure 2. Test Load Circuit

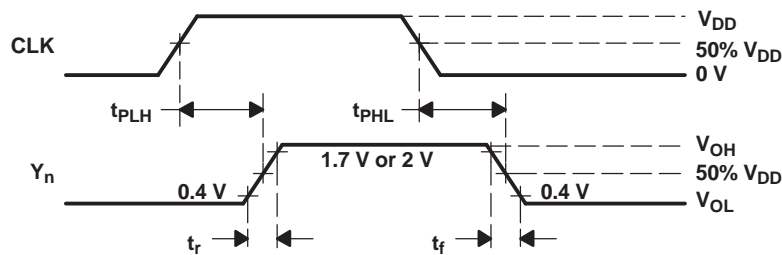

Figure 3. Voltage Waveforms Propagation Delay Times

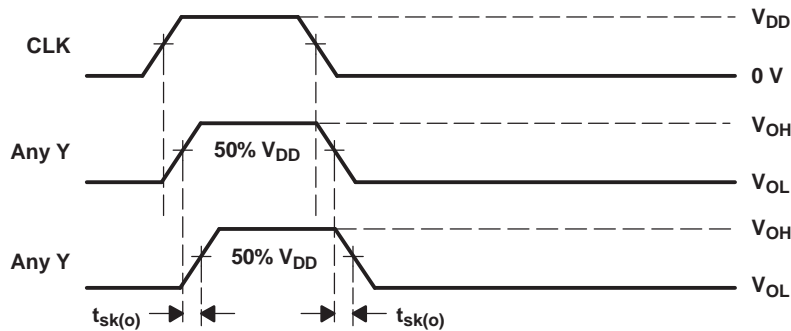
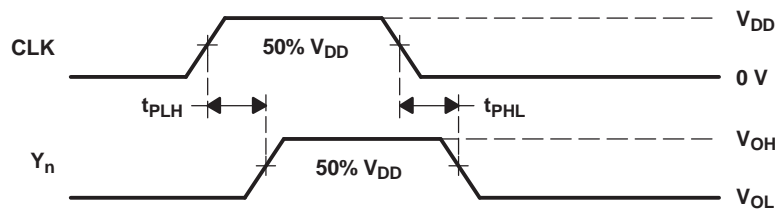

Figure 4. Output Skew



NOTE: $t_{sk(p)} = |t_{PLH} - t_{PHL}|$

Figure 5. Pulse Skew

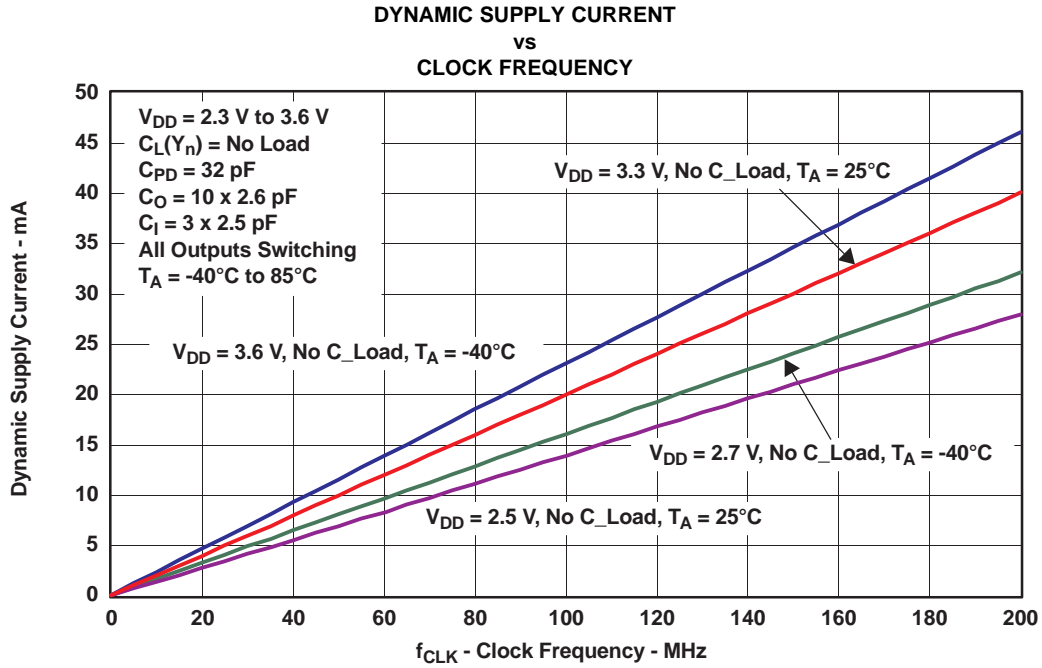

Figure 6.

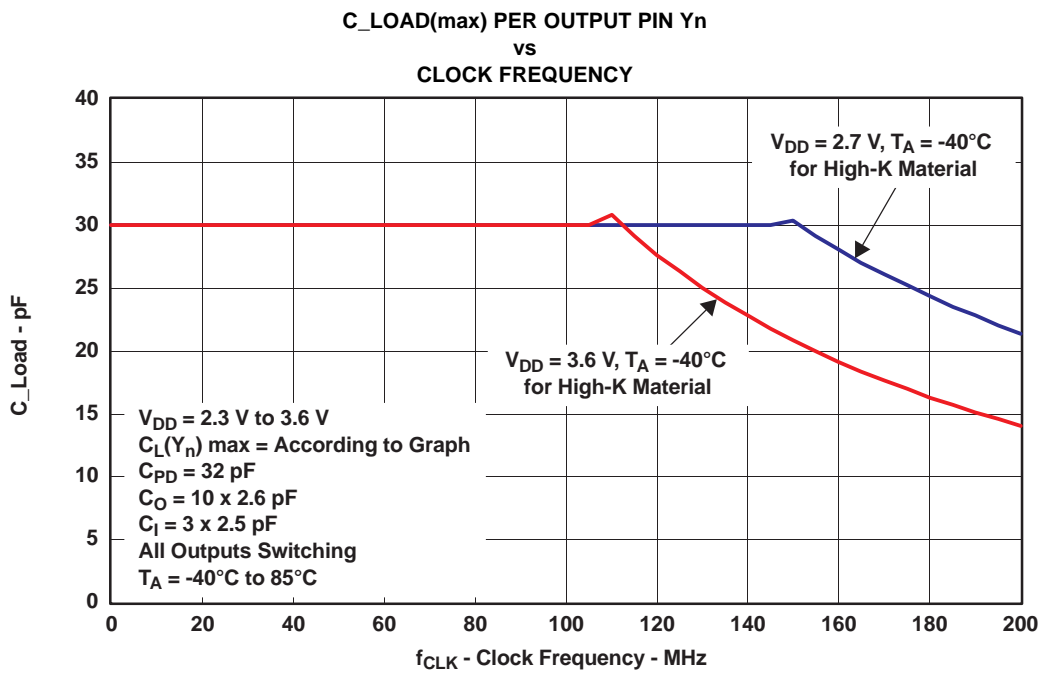

Figure 7.

PACKAGING INFORMATION

Orderable Device	Status (1)	Package Type	Package Drawing	Pins	Package Qty	Eco Plan (2)	Lead finish/ Ball material (6)	MSL Peak Temp (3)	Op Temp (°C)	Device Marking (4/5)	Samples
CDCVF310PW	ACTIVE	TSSOP	PW	24	60	RoHS & Green	NIPDAU	Level-1-260C-UNLIM	-40 to 85	CKV310	Samples
CDCVF310PWR	ACTIVE	TSSOP	PW	24	2000	RoHS & Green	NIPDAU	Level-1-260C-UNLIM	-40 to 85	CKV310	Samples

(1) The marketing status values are defined as follows:

ACTIVE: Product device recommended for new designs.

LIFEBUY: TI has announced that the device will be discontinued, and a lifetime-buy period is in effect.

NRND: Not recommended for new designs. Device is in production to support existing customers, but TI does not recommend using this part in a new design.

PREVIEW: Device has been announced but is not in production. Samples may or may not be available.

OBSOLETE: TI has discontinued the production of the device.

(2) **RoHS:** TI defines "RoHS" to mean semiconductor products that are compliant with the current EU RoHS requirements for all 10 RoHS substances, including the requirement that RoHS substance do not exceed 0.1% by weight in homogeneous materials. Where designed to be soldered at high temperatures, "RoHS" products are suitable for use in specified lead-free processes. TI may reference these types of products as "Pb-Free".

RoHS Exempt: TI defines "RoHS Exempt" to mean products that contain lead but are compliant with EU RoHS pursuant to a specific EU RoHS exemption.

Green: TI defines "Green" to mean the content of Chlorine (Cl) and Bromine (Br) based flame retardants meet JS709B low halogen requirements of <=1000ppm threshold. Antimony trioxide based flame retardants must also meet the <=1000ppm threshold requirement.

(3) MSL, Peak Temp. - The Moisture Sensitivity Level rating according to the JEDEC industry standard classifications, and peak solder temperature.

(4) There may be additional marking, which relates to the logo, the lot trace code information, or the environmental category on the device.

(5) Multiple Device Markings will be inside parentheses. Only one Device Marking contained in parentheses and separated by a "~" will appear on a device. If a line is indented then it is a continuation of the previous line and the two combined represent the entire Device Marking for that device.

(6) Lead finish/Ball material - Orderable Devices may have multiple material finish options. Finish options are separated by a vertical ruled line. Lead finish/Ball material values may wrap to two lines if the finish value exceeds the maximum column width.

Important Information and Disclaimer:The information provided on this page represents TI's knowledge and belief as of the date that it is provided. TI bases its knowledge and belief on information provided by third parties, and makes no representation or warranty as to the accuracy of such information. Efforts are underway to better integrate information from third parties. TI has taken and continues to take reasonable steps to provide representative and accurate information but may not have conducted destructive testing or chemical analysis on incoming materials and chemicals. TI and TI suppliers consider certain information to be proprietary, and thus CAS numbers and other limited information may not be available for release.

In no event shall TI's liability arising out of such information exceed the total purchase price of the TI part(s) at issue in this document sold by TI to Customer on an annual basis.

TAPE AND REEL INFORMATION

QUADRANT ASSIGNMENTS FOR PIN 1 ORIENTATION IN TAPE



*All dimensions are nominal

Device	Package Type	Package Drawing	Pins	SPQ	Reel Diameter (mm)	Reel Width W1 (mm)	A0 (mm)	B0 (mm)	K0 (mm)	P1 (mm)	W (mm)	Pin1 Quadrant
CDCVF310PWR	TSSOP	PW	24	2000	330.0	16.4	6.95	8.3	1.6	8.0	16.0	Q1

TAPE AND REEL BOX DIMENSIONS

*All dimensions are nominal

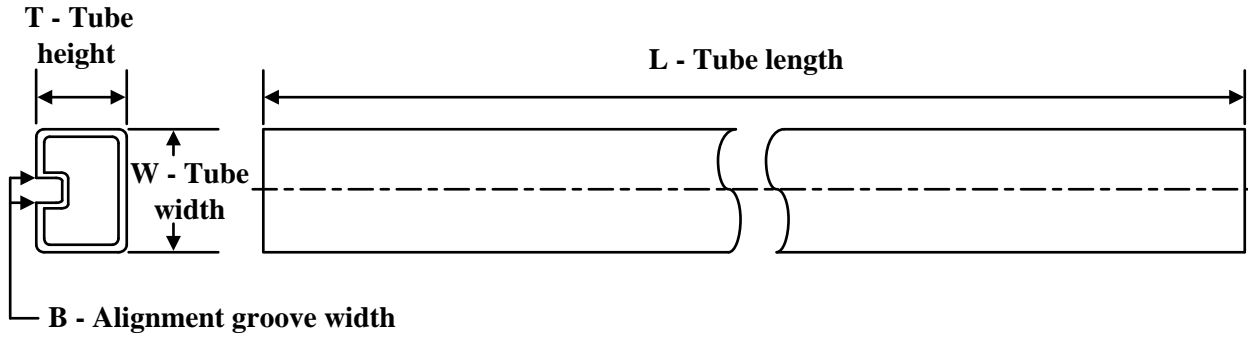
Device	Package Type	Package Drawing	Pins	SPQ	Length (mm)	Width (mm)	Height (mm)
CDCVF310PWR	TSSOP	PW	24	2000	356.0	356.0	35.0

TUBE

*All dimensions are nominal

Device	Package Name	Package Type	Pins	SPQ	L (mm)	W (mm)	T (μm)	B (mm)
CDCVF310PW	PW	TSSOP	24	60	530	10.2	3600	3.5

EXAMPLE BOARD LAYOUT

PW0024A

TSSOP - 1.2 mm max height

SMALL OUTLINE PACKAGE



LAND PATTERN EXAMPLE
EXPOSED METAL SHOWN
SCALE: 10X

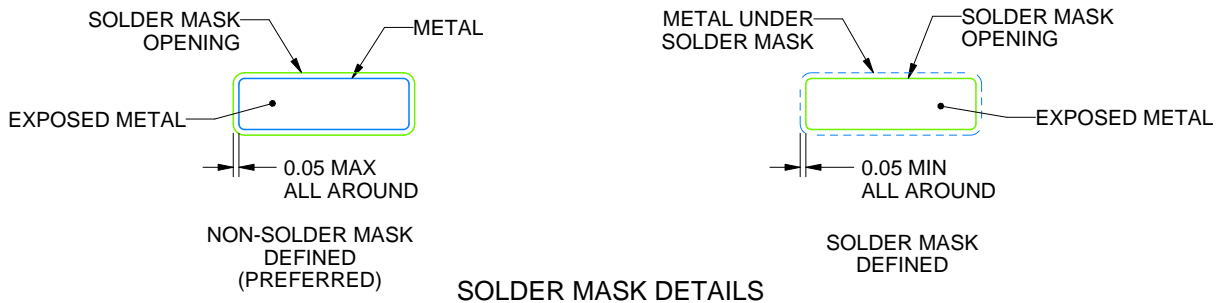

SOLDER MASK DETAILS

4220208/A 02/2017

NOTES: (continued)

- 6. Publication IPC-7351 may have alternate designs.
- 7. Solder mask tolerances between and around signal pads can vary based on board fabrication site.

EXAMPLE STENCIL DESIGN

PW0024A

TSSOP - 1.2 mm max height

SMALL OUTLINE PACKAGE



NOTES: (continued)

8. Laser cutting apertures with trapezoidal walls and rounded corners may offer better paste release. IPC-7525 may have alternate design recommendations.
9. Board assembly site may have different recommendations for stencil design.

IMPORTANT NOTICE AND DISCLAIMER

TI PROVIDES TECHNICAL AND RELIABILITY DATA (INCLUDING DATA SHEETS), DESIGN RESOURCES (INCLUDING REFERENCE DESIGNS), APPLICATION OR OTHER DESIGN ADVICE, WEB TOOLS, SAFETY INFORMATION, AND OTHER RESOURCES "AS IS" AND WITH ALL FAULTS, AND DISCLAIMS ALL WARRANTIES, EXPRESS AND IMPLIED, INCLUDING WITHOUT LIMITATION ANY IMPLIED WARRANTIES OF MERCHANTABILITY, FITNESS FOR A PARTICULAR PURPOSE OR NON-INFRINGEMENT OF THIRD PARTY INTELLECTUAL PROPERTY RIGHTS.

These resources are intended for skilled developers designing with TI products. You are solely responsible for (1) selecting the appropriate TI products for your application, (2) designing, validating and testing your application, and (3) ensuring your application meets applicable standards, and any other safety, security, regulatory or other requirements.

These resources are subject to change without notice. TI grants you permission to use these resources only for development of an application that uses the TI products described in the resource. Other reproduction and display of these resources is prohibited. No license is granted to any other TI intellectual property right or to any third party intellectual property right. TI disclaims responsibility for, and you will fully indemnify TI and its representatives against, any claims, damages, costs, losses, and liabilities arising out of your use of these resources.

TI's products are provided subject to [TI's Terms of Sale](#) or other applicable terms available either on ti.com or provided in conjunction with such TI products. TI's provision of these resources does not expand or otherwise alter TI's applicable warranties or warranty disclaimers for TI products.

TI objects to and rejects any additional or different terms you may have proposed.

Mailing Address: Texas Instruments, Post Office Box 655303, Dallas, Texas 75265
Copyright © 2022, Texas Instruments Incorporated

Looking for pricing, stock, or lifecycle information?

Click below to explore more details on WIN SOURCE:

 [View CDCVF310PWRG4](#) on WIN SOURCE

 [Texas Instruments](#) Information

Optimize Your Supply Chain with WIN SOURCE Solutions

-  Global Sourcing Solution
-  Obsolete Management
-  Cost Control Management
-  Shortage Management
-  Alternative Solution
-  Excess Inventory Management