



**THE DATASHEET OF
CY2303SXCT**



Phase-Aligned Clock Multiplier

Features

- 3-Multiplier configuration (1×, 2×, 4× ref)
- 10 MHz to 166.67 MHz operating range (reference input from 10 MHz to 41.67 MHz)
- Phase alignment
- 80 ps typical period jitter
- Output enable pin
- 3.3 V operation
- 5 V tolerant input
- 8-pin 150-mil small-outline integrated circuit (SOIC) package
- Commercial temperature range

Functional Description

The CY2303 is a 3 output 3.3 V phase-aligned system clock designed to distribute high-speed clocks in PC, workstation, datacom, telecom, and other high-performance applications.

The part allows user to obtain 1×, 2×, and 4× REFIN output frequencies on respective output pins.

The CY2303 has an on-chip PLL, which locks to an input clock presented on the REFIN pin. The PLL feedback is internally connected to the REF output. The input-to-output is guaranteed to be less than ±200 ps, and output-to-output skew is guaranteed to be less than 200 ps.

Multiple CY2303 devices can accept the same input clock and distribute it in a system. In this case, the skew between the outputs of two devices is guaranteed to be less than 400 ps.

For a complete list of related documentation, click [here](#).

Logic Block Diagram

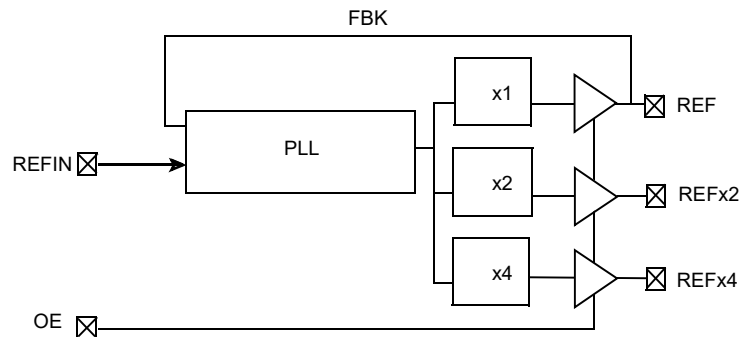

Contents

Pin Configurations	3	Reference Documents	10
Pin Description	3	Errata	11
Maximum Ratings	4	Part Numbers Affected	11
Operating Conditions	4	CY2303 Errata Summary	11
Electrical Characteristics	4	CY2303 Qualification Status of fixed silicon	11
Thermal Resistance	4	Document History Page	13
Switching Characteristics	5	Sales, Solutions, and Legal Information	14
Switching Waveforms	6	Worldwide Sales and Design Support	14
Test Circuits	7	Products	14
Ordering Information	8	PSoC® Solutions	14
Ordering Code Definitions	8	Cypress Developer Community	14
Package Diagram	9	Technical Support	14
Acronyms	10		
Document Conventions	10		
Units of Measure	10		

Pin Configurations

Figure 1. 8-pin SOIC pinout

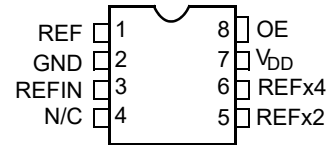

Pin Description

Pin	Signal ^[1]	Description
1	REF	REF output (1× reference input)
2	GND	Ground
3	REFIN	Input reference frequency, 5 V tolerant input
4	N/C	No connect
5	REF×2	2× reference input
6	REF×4	4× reference input
7	V _{DD}	3.3 V supply
8	OE	Output enable (weak pull-up)

Note

1. Weak pull-down on all outputs.

Maximum Ratings

Supply voltage to ground potential -0.5 V to +7.0 V
 DC input voltage (except ref) -0.5 V to $V_{DD} + 0.5$ V
 DC input voltage REFIN -0.5 V to 7 V

Storage temperature -65 °C to +150 °C
 Junction temperature 150 °C
 Static discharge voltage
 (per MIL-STD-883, method 3015) > 2000 V

Operating Conditions

Parameter	Description	Min	Max	Unit
V_{DD}	Supply voltage	3.0	3.6	V
T_A	Operating temperature (ambient temperature)	0	70	°C
C_L	Load capacitance, 10 MHz < F_{OUT} < 133.33 MHz	–	18	pF
	Load capacitance, 133.33 MHz < F_{OUT} < 166.67 MHz	–	12	pF
C_{IN}	Input capacitance	–	7	pF
t_{PU}	Power-up time for all V_{DD} 's to reach minimum specified voltage (power ramps must be monotonic)	0.05	50	ms

Electrical Characteristics

Parameter	Description	Test Conditions	Min	Max	Unit
V_{IL}	Input LOW voltage		–	0.8	V
V_{IH}	Input HIGH voltage		2.0	–	V
I_{IL}	Input LOW current	$V_{IN} = 0$ V	–	100	μA
I_{IH}	Input HIGH current	$V_{IN} = V_{DD}$	–	50	μA
V_{OL}	Output LOW voltage [2]	$I_{OL} = 8$ mA	–	0.4	V
V_{OH}	Output HIGH voltage [2]	$I_{OH} = -8$ mA	2.4	–	V
I_{DD}	Supply current	Unloaded outputs, REFIN = 41.67 MHz	–	45	mA
		Unloaded outputs, REFIN = 25 MHz	–	32	mA
		Unloaded outputs, REFIN = 10 MHz	–	18	mA

Thermal Resistance

Parameter [3]	Description	Test Conditions	8-pin SOIC	Unit
θ_{JA}	Thermal resistance (junction to ambient)	Test conditions follow standard test methods and procedures for measuring thermal impedance, in accordance with EIA/JESD51.	140	°C/W
θ_{JC}	Thermal resistance (junction to case)		54	°C/W

Notes

- Parameter is guaranteed by design and characterization. It is not 100% tested in production.
- These parameters are guaranteed by design and are not tested.

Switching Characteristics

Parameter	Name	Test Conditions	Min	Typ	Max	Unit
1/t ₁	Output frequency	18-pF load	10	–	133.33	MHz
		12-pF load	–	–	166.67	MHz
	Duty cycle ^[4] = t ₂ ÷ t ₁	Measured at V _{DD} /2	40	50	60	%
t ₃	Rise time ^[4]	Measured between 0.8 V and 2.0 V	–	–	1.20	ns
t ₄	Fall time ^[4]	Measured between 0.8 V and 2.0 V	–	–	1.20	ns
t ₅	Output to output skew on rising edges ^[4]	All outputs equally loaded Measured at V _{DD} /2	–	–	200	ps
t ₆	Delay, REFIN rising edge to REF rising edge ^[4]	Measured at V _{DD} /2 from REFIN to any output	–	–	±200	ps
t ₇	Device to device skew ^[4]	Measured at V _{DD} /2 on the REF pin of the device (pin 1)	–	–	400	ps
t _J	Period jitter ^[4]	Measured at F _{OUT} < 133.33 MHz, loaded outputs, 18-pF load	–	±80	±175	ps
t _{LOCK}	PLL lock time ^[4]	Stable power supply, valid clocks presented on REFIN	–	–	1.0	ms

Note

4. All parameters are specified with loaded outputs.

Switching Waveforms

Figure 2. Duty Cycle Timing

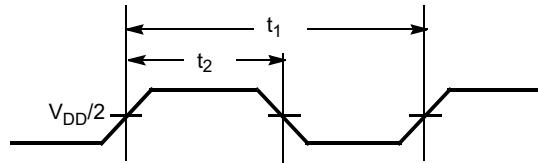

Figure 3. All Outputs Rise/Fall Time

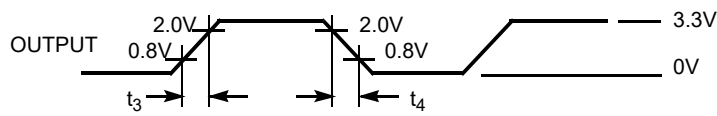

Figure 4. Output to Output Skew

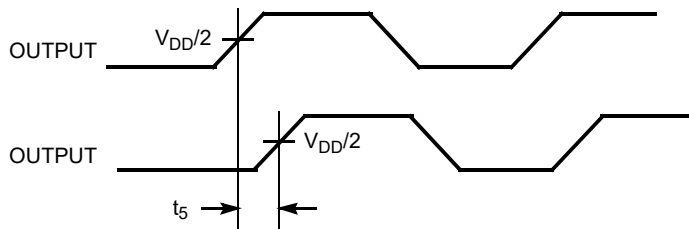

Figure 5. Input to Output Propagation Delay

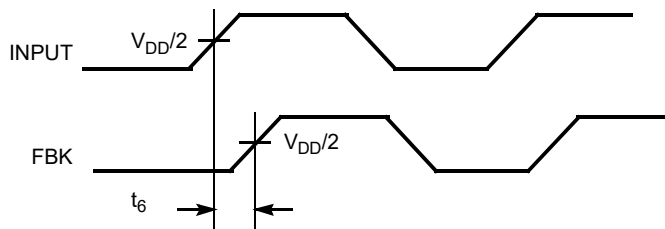
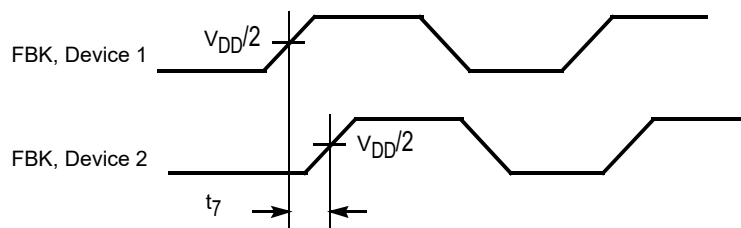
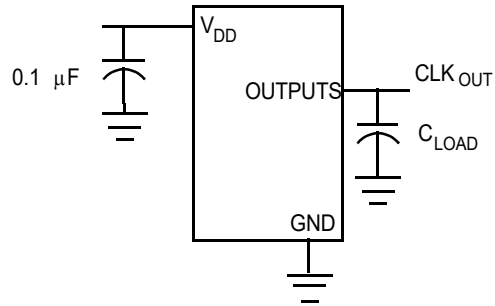

Figure 6. Device to Device Skew



Test Circuits

Figure 7. Test Circuit #1



Ordering Information

Ordering Code	Package Type	Operating Range
Pb-free		
CY2303SXC	8-pin SOIC (150 Mils)	Commercial (0 °C to 70 °C)
CY2303SXCT	8-pin SOIC (150 Mils) - Tape and Reel	Commercial (0 °C to 70 °C)

Ordering Code Definitions

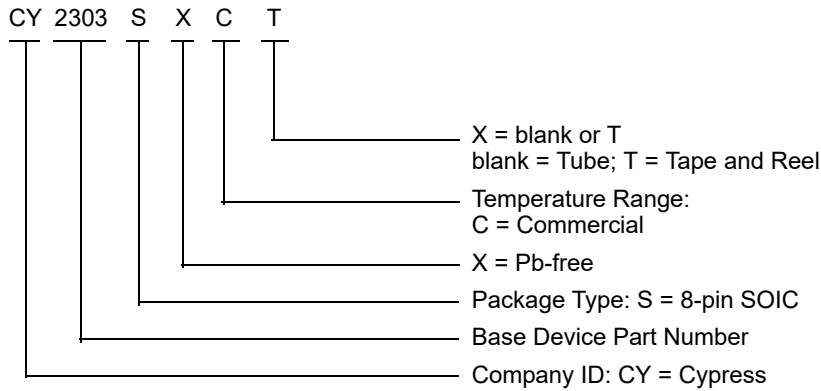

Package Diagram

Figure 8. 8-pin SOIC (150 Mils) S0815/SZ815/SW815 Package Outline, 51-85066

1. DIMENSIONS IN INCHES[MM] MIN. MAX.
2. PIN 1 ID IS OPTIONAL, ROUND ON SINGLE LEADFRAME RECTANGULAR ON MATRIX LEADFRAME
3. REFERENCE JEDEC MS-012
4. PACKAGE WEIGHT 0.07gms

PART #	
S08.15	STANDARD PKG
SZ08.15	LEAD FREE PKG
SW8.15	LEAD FREE PKG

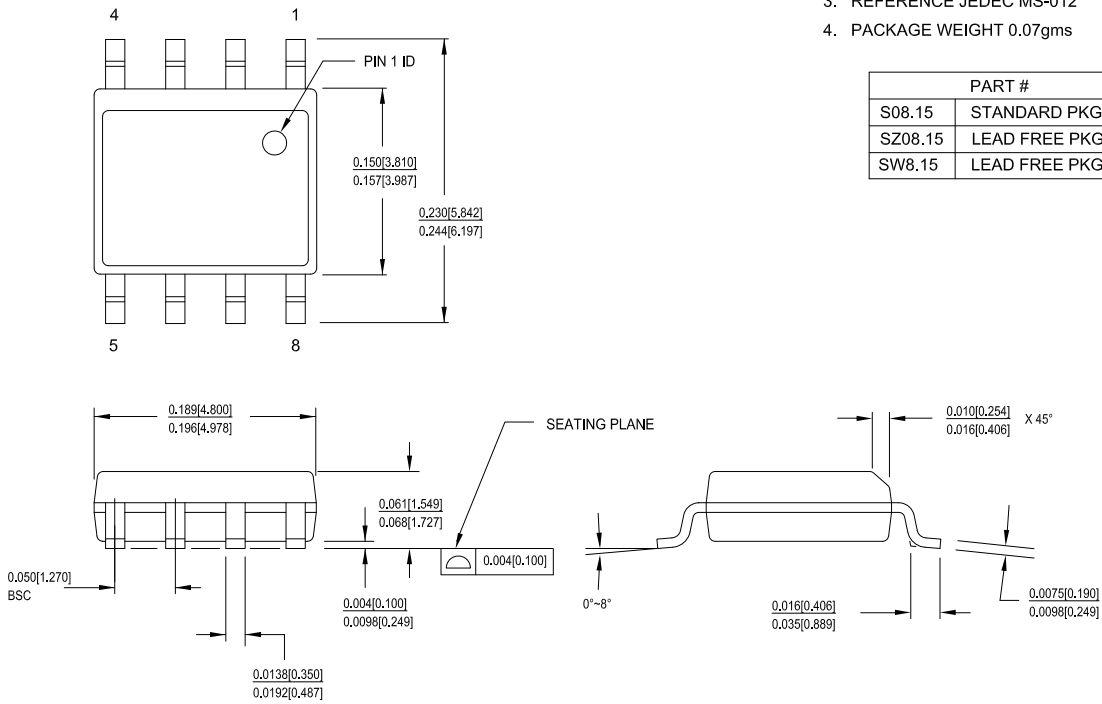

51-85066 *I

Acronyms

Acronym	Description
FBK	Feedback
OE	Output Enable
PLL	Phase Locked Loop
REFIN	Reference Input

Document Conventions

Units of Measure

Symbol	Unit of Measure
°C	degrees Celsius
Hz	hertz
kHz	kilohertz
MHz	megahertz
μA	microampere
μF	microfarad
μs	microsecond
μV	microvolt
mA	milliampere
mm	millimeter
ms	millisecond
mV	millivolt
ns	nanosecond
pA	picoampere
pF	picofarad
ps	picosecond
V	volt

Reference Documents

Reference documents are available through your local Cypress sales representative. You can also direct your requests to tsbusdev@cypress.com.

Document Number	Document Title	Description
NA	NA	NA

Errata

This section describes the errors, workaround solution and silicon design fixes for Cypress zero delay clock buffers belonging to the families CY2303. Details include errata trigger conditions, scope of impact, available workarounds, and silicon revision applicability. Contact your local Cypress Sales Representative if you have questions.

Part Numbers Affected

Table 1. Part Numbers Affected

Part Number	Device Variants
CY2303SXC	All Variants
CY2303SXCT	All Variants

CY2303 Errata Summary

Items	Part Number	Fix Status
Start up lock time issue [CY2303]	All	Silicon fixed. New silicon available from WW 10 of 2013

CY2303 Qualification Status of fixed silicon

Product Status: In production

Qualification report last updated on 11/27/2012

<http://www.cypress.com/?rID=72595>

1. Start up lock time issue

■ Problem Definition

Output of CY2304 fails to locks within 1 ms upon power up (as per datasheet spec)

■ Parameters Affected

PLL lock time

■ Trigger Condition(s)

Start up

■ Scope of Impact

It can impact the performance of system and its throughput

■ Workaround

Apply reference input (RefClk) before power up (V_{DD}). If RefClk is applied after power up, noise gets coupled on the output and propagates back to the PLL causing it to take higher time to acquire lock. If reference input is present during power up, noise will not propagate to the PLL and device will start up normally without problems.

■ Fix Status

This issue is due to design marginality. Two minor design modifications have been made to address this problem.

- Addition of VCO bias detector block as shown in the following figure keeps comparator power down till VCO bias is present and thereby eliminating the propagation of noise to feedback.
- Bias generator enhancement for successful initialization.

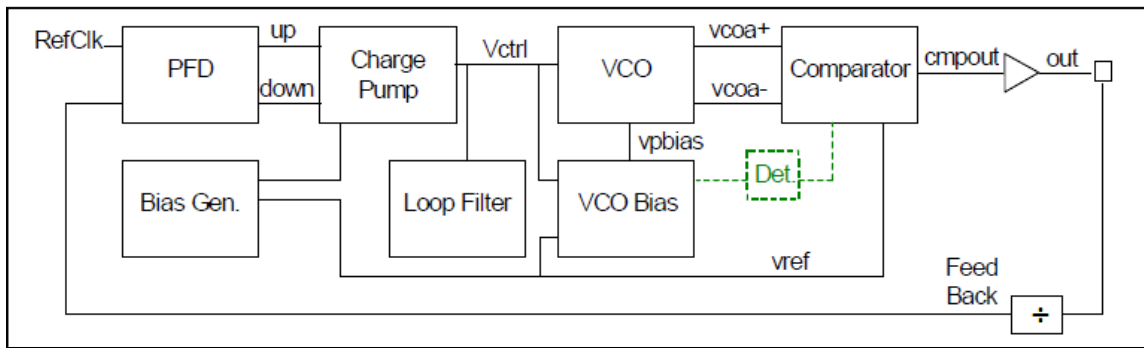

Document History Page

Document Title: CY2303, Phase-Aligned Clock Multiplier Document Number: 38-07249				
Rev.	ECN	Orig. of Change	Submission Date	Description of Change
**	110514	SZV	01/07/2002	Changed from spec number: 38-01036 to 38-07249.
*A	121852	RBI	12/14/2002	Updated Operating Conditions : Added t _{PU} parameter and its details.
*B	390413	RGL	08/10/2005	Updated Switching Characteristics : Added typical value for t _J parameter. Updated Ordering Information : Updated part numbers.
*C	2568533	AESA	09/23/2008	Updated Selector Guide: Removed CY2303SC and CY2303SI part number related information. Updated Ordering Information : Updated part numbers. Updated to new template.
*D	2897294	KVM	03/22/2010	Removed Industrial Temperature Range related information in all instances across the document. Removed Selector Guide. Updated Ordering Information : Updated part numbers. Updated Package Diagram : spec 51-85066 – Changed revision from *C to *D. Updated to new template.
*E	3026183	BASH	09/01/2010	Updated Switching Characteristics : Changed typical value of t _J parameter from 80 ps to ±80 ps. Updated Ordering Information : No change in part numbers. Added Ordering Code Definitions . Added Acronyms , and Units of Measure . Added Reference Documents . Completing Sunset Review.
*F	4018186	CINM	06/10/2013	Updated Package Diagram : spec 51-85066 – Changed revision from *D to *F. Added Errata .
*G	4127379	CINM	10/23/2013	Updated to new template. Completing Sunset Review.
*H	4578443	TAVA	10/25/2014	Updated Functional Description : Added “For a complete list of related documentation, click here .” at the end.
*I	5270465	PSR	05/13/2016	Added Thermal Resistance . Updated Package Diagram : spec 51-85066 – Changed revision from *F to *H. Updated to new template.
*J	5515677	TAVA	11/09/2016	Updated to new template. Completing Sunset Review.
*K	6043496	PAWK	01/24/2018	Updated Package Diagram : spec 51-85066 – Changed revision from *H to *I. Updated to new template.

Sales, Solutions, and Legal Information

Worldwide Sales and Design Support

Cypress maintains a worldwide network of offices, solution centers, manufacturer's representatives, and distributors. To find the office closest to you, visit us at [Cypress Locations](#).

Products

Arm® Cortex® Microcontrollers	cypress.com/arm
Automotive	cypress.com/automotive
Clocks & Buffers	cypress.com/clocks
Interface	cypress.com/interface
Internet of Things	cypress.com/iot
Memory	cypress.com/memory
Microcontrollers	cypress.com/mcu
PSoC	cypress.com/psoc
Power Management ICs	cypress.com/pmic
Touch Sensing	cypress.com/touch
USB Controllers	cypress.com/usb
Wireless Connectivity	cypress.com/wireless

PSoC® Solutions

[PSoC 1](#) | [PSoC 3](#) | [PSoC 4](#) | [PSoC 5LP](#) | [PSoC 6 MCU](#)

Cypress Developer Community

[Community](#) | [Projects](#) | [Video](#) | [Blogs](#) | [Training](#) | [Components](#)

Technical Support

cypress.com/support

© Cypress Semiconductor Corporation, 2002-2018. This document is the property of Cypress Semiconductor Corporation and its subsidiaries, including Spansion LLC ("Cypress"). This document, including any software or firmware included or referenced in this document ("Software"), is owned by Cypress under the intellectual property laws and treaties of the United States and other countries worldwide. Cypress reserves all rights under such laws and treaties and does not, except as specifically stated in this paragraph, grant any license under its patents, copyrights, trademarks, or other intellectual property rights. If the Software is not accompanied by a license agreement and you do not otherwise have a written agreement with Cypress governing the use of the Software, then Cypress hereby grants you a personal, non-exclusive, nontransferable license (without the right to sublicense) (1) under its copyright rights in the Software (a) for Software provided in source code form, to modify and reproduce the Software solely for use with Cypress hardware products, only internally within your organization, and (b) to distribute the Software in binary code form externally to end users (either directly or indirectly through resellers and distributors), solely for use on Cypress hardware product units, and (2) under those claims of Cypress's patents that are infringed by the Software (as provided by Cypress, unmodified) to make, use, distribute, and import the Software solely for use with Cypress hardware products. Any other use, reproduction, modification, translation, or compilation of the Software is prohibited.

TO THE EXTENT PERMITTED BY APPLICABLE LAW, CYPRESS MAKES NO WARRANTY OF ANY KIND, EXPRESS OR IMPLIED, WITH REGARD TO THIS DOCUMENT OR ANY SOFTWARE OR ACCOMPANYING HARDWARE, INCLUDING, BUT NOT LIMITED TO, THE IMPLIED WARRANTIES OF MERCHANTABILITY AND FITNESS FOR A PARTICULAR PURPOSE. To the extent permitted by applicable law, Cypress reserves the right to make changes to this document without further notice. Cypress does not assume any liability arising out of the application or use of any product or circuit described in this document. Any information provided in this document, including any sample design information or programming code, is provided only for reference purposes. It is the responsibility of the user of this document to properly design, program, and test the functionality and safety of any application made of this information and any resulting product. Cypress products are not designed, intended, or authorized for use as critical components in systems designed or intended for the operation of weapons, weapons systems, nuclear installations, life-support devices or systems, other medical devices or systems (including resuscitation equipment and surgical implants), pollution control or hazardous substances management, or other uses where the failure of the device or system could cause personal injury, death, or property damage ("Unintended Uses"). A critical component is any component of a device or system whose failure to perform can be reasonably expected to cause the failure of the device or system, or to affect its safety or effectiveness. Cypress is not liable, in whole or in part, and you shall and hereby do release Cypress from any claim, damage, or other liability arising from or related to all Unintended Uses of Cypress products. You shall indemnify and hold Cypress harmless from and against all claims, costs, damages, and other liabilities, including claims for personal injury or death, arising from or related to any Unintended Uses of Cypress products.

Cypress, the Cypress logo, Spansion, the Spansion logo, and combinations thereof, WICED, PSoC, CapSense, EZ-USB, F-RAM, and Traveo are trademarks or registered trademarks of Cypress in the United States and other countries. For a more complete list of Cypress trademarks, visit cypress.com. Other names and brands may be claimed as property of their respective owners.

Looking for pricing, stock, or lifecycle information?

Click below to explore more details on WIN SOURCE:

 [View CY2303SXCT on WIN SOURCE](#)

 [Infineon Technologies](#) Information

Optimize Your Supply Chain with WIN SOURCE Solutions

-  Global Sourcing Solution
-  Obsolete Management
-  Cost Control Management
-  Shortage Management
-  Alternative Solution
-  Excess Inventory Management