



**THE DATASHEET OF  
TPS84410RKGR**



## 2.95-V to 6-V Input, 4-A Synchronous Buck, Integrated Power Solution

Check for Samples: [TPS84410](#)

### FEATURES

- Complete Integrated Power Solution Allows Small Footprint, Low-Profile Design
- Efficiencies Up To 96%
- Wide-Output Voltage Adjust 0.8 V to 3.6 V, with  $\pm 1\%$  Reference Accuracy
- Adjustable Switching Frequency (500 kHz to 2 MHz)
- Synchronizes to an External Clock
- Adjustable Slow-Start
- Output Voltage Sequencing / Tracking
- Power Good Output
- Programmable Undervoltage Lockout (UVLO)
- Output Overcurrent Protection
- Over Temperature Protection
- Operating Temperature Range:  $-40^{\circ}\text{C}$  to  $85^{\circ}\text{C}$
- Enhanced Thermal Performance:  $12^{\circ}\text{C/W}$
- Meets EN55022 Class B Emissions
- For Design Help Including SwitcherPro™ visit <http://www.ti.com/TPS84410>

### APPLICATIONS

- Broadband & Communications Infrastructure
- Automated Test and Medical Equipment
- Compact PCI / PCI Express / PXI Express
- DSP and FPGA Point of Load Applications
- High Density Distributed Power Systems

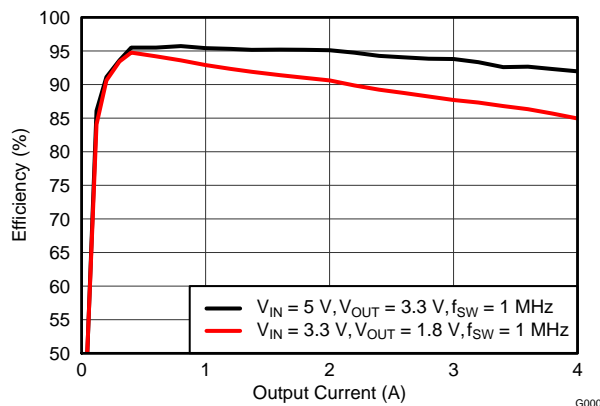

### DESCRIPTION

The TPS84410RKG is an easy-to-use integrated power solution that combines a 4-A DC/DC converter with power MOSFETs, an inductor, and passives into a low profile, BQFN package. This total power solution requires as few as 3 external components and eliminates the loop compensation and magnetics part selection process.

The  $9 \times 11 \times 2.8$  mm BQFN package is easy to solder onto a printed circuit board and allows a compact point-of-load design with greater than 90% efficiency and excellent power dissipation with a thermal impedance of  $12^{\circ}\text{C/W}$  junction to ambient. The device delivers the full 4-A rated output current at  $85^{\circ}\text{C}$  ambient temperature without airflow.

The TPS84410 offers the flexibility and the feature-set of a discrete point-of-load design and is ideal for powering performance DSPs and FPGAs. Advanced packaging technology afford a robust and reliable power solution compatible with standard QFN mounting and testing techniques.

### SIMPLIFIED APPLICATION

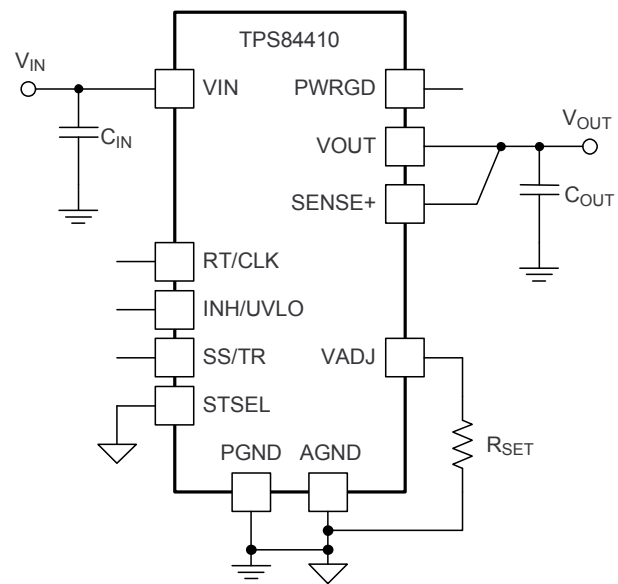

Please be aware that an important notice concerning availability, standard warranty, and use in critical applications of Texas Instruments semiconductor products and disclaimers thereto appears at the end of this data sheet.

SwitcherPro is a trademark of Texas Instruments.

PRODUCTION DATA information is current as of publication date. Products conform to specifications per the terms of the Texas Instruments standard warranty. Production processing does not necessarily include testing of all parameters.

Copyright © 2011–2012, Texas Instruments Incorporated



This integrated circuit can be damaged by ESD. Texas Instruments recommends that all integrated circuits be handled with appropriate precautions. Failure to observe proper handling and installation procedures can cause damage.

ESD damage can range from subtle performance degradation to complete device failure. Precision integrated circuits may be more susceptible to damage because very small parametric changes could cause the device not to meet its published specifications.

**ORDERING INFORMATION<sup>(1)</sup>**

TA	PACKAGE	ORDERABLE NUMBER	PINS	TRANSPORT MEDIA	MINIMUM QUANTITY	ECO PLAN
-40°C to 85°C	Plastic Quad Flat Pack (BQFN)	TPS84410RKGR	39	Tape and Reel	500	Green (RoHS and no Sb/Br)
		TPS84410RKGT		Tape and Reel	250	Green (RoHS and no Sb/Br)

(1) For the most current package and ordering information, see the *Package Option Addendum* at the end of this datasheet, or see the TI website at [www.ti.com](http://www.ti.com).

**ABSOLUTE MAXIMUM RATINGS<sup>(1)</sup> over operating temperature range (unless otherwise noted)**

		VALUE		UNIT
		MIN	MAX	
Input Voltage	VIN, PWRGD	-0.3	7	V
	INH/UVLO, RT/CLK	-0.3	3.3	V
	SS/TR, STSEL, VADJ	-0.3	3	V
	SENSE+   VADJ rating must also be met	-0.3	VOUT	V
Output Voltage	PH	-0.6	7	V
	PH 10ns Transient	-2	7	V
	VOUT	-0.6	VIN	V
V <sub>DIFF</sub> (GND to exposed thermal pad)		-0.2	0.2	V
Source Current	RT/CLK, INH/UVLO		±100	µA
	PH		Current Limit	A
Sink Current	PH		Current Limit	A
	SS/TR		±100	µA
	PWRGD		10	mA
Operating Junction Temperature		-40	125 <sup>(2)</sup>	°C
Storage Temperature		-65	150	°C
Mechanical Shock	Mil-STD-883D, Method 2002.3, 1 msec, 1/2 sine, mounted		1500	G
Mechanical Vibration	Mil-STD-883D, Method 2007.2, 20-2000Hz		20	

- (1) Stresses beyond those listed under absolute maximum ratings may cause permanent damage to the device. These are stress ratings only, and functional operation of the device at these or any other conditions beyond those indicated under recommended operating conditions is not implied. Exposure to absolute-maximum-rated conditions for extended periods may affect device reliability.
- (2) See the temperature derating curves in the Typical Characteristics section for thermal information.

**THERMAL INFORMATION**

THERMAL METRIC <sup>(1)</sup>		TPS84410	UNIT
		RKG39	
		39 PINS	
$\theta_{JA}$	Junction-to-ambient thermal resistance <sup>(2)</sup>	12	°C/W
$\psi_{JT}$	Junction-to-top characterization parameter <sup>(3)</sup>	2.2	
$\psi_{JB}$	Junction-to-board characterization parameter <sup>(4)</sup>	9.7	

- (1) For more information about traditional and new thermal metrics, see the IC Package Thermal Metrics application report, [SPRA953](#).
- (2) The junction-to-ambient thermal resistance,  $\theta_{JA}$ , applies to devices soldered directly to a 100 mm x 100 mm double-sided PCB with 1 oz. copper and natural convection cooling. Additional airflow reduces  $\theta_{JA}$ .
- (3) The junction-to-top characterization parameter,  $\psi_{JT}$ , estimates the junction temperature,  $T_J$ , of a device in a real system, using a procedure described in JESD51-2A (sections 6 and 7).  $T_J = \psi_{JT} * P_{dis} + T_T$ ; where  $P_{dis}$  is the power dissipated in the device and  $T_T$  is the temperature of the top of the device.
- (4) The junction-to-board characterization parameter,  $\psi_{JB}$ , estimates the junction temperature,  $T_J$ , of a device in a real system, using a procedure described in JESD51-2A (sections 6 and 7).  $T_J = \psi_{JB} * P_{dis} + T_B$ ; where  $P_{dis}$  is the power dissipated in the device and  $T_B$  is the temperature of the board 1mm from the device.

**PACKAGE SPECIFICATIONS**

TPS84410		UNIT
Weight		0.85 grams
Flammability	Meets UL 94 V-O	
MTBF Calculated reliability	Per Bellcore TR-332, 50% stress, $T_A = 40^\circ\text{C}$ , ground benign	32.8 MHrs

## ELECTRICAL CHARACTERISTICS

Over  $-40^{\circ}\text{C}$  to  $85^{\circ}\text{C}$  free-air temperature,  $V_{\text{IN}} = 3.3\text{ V}$ ,  $V_{\text{OUT}} = 1.8\text{ V}$ ,  $I_{\text{OUT}} = 4\text{ A}$ ,  
 $C_{\text{IN}1} = 47\text{ }\mu\text{F}$  ceramic,  $C_{\text{IN}2} = 220\text{ }\mu\text{F}$  poly-tantalum,  $C_{\text{OUT}1} = 47\text{ }\mu\text{F}$  ceramic,  $C_{\text{OUT}2} = 100\text{ }\mu\text{F}$  poly-tantalum (unless otherwise noted)

PARAMETER		TEST CONDITIONS	MIN	TYP	MAX	UNIT
$I_{\text{OUT}}$	Output current	$T_{\text{A}} = 85^{\circ}\text{C}$ , natural convection	0		4	A
$V_{\text{IN}}$	Input voltage range	Over $I_{\text{OUT}}$ range	2.95 <sup>(1)</sup>		6	V
$UVLO$	$V_{\text{IN}}$ Undervoltage lockout	$V_{\text{IN}} = \text{increasing}$		3.05	3.135	V
		$V_{\text{IN}} = \text{decreasing}$	2.5	2.75		
$V_{\text{OUT(adj)}}$	Output voltage adjust range	Over $I_{\text{OUT}}$ range	0.8		3.6	V
$V_{\text{OUT}}$	Set-point voltage tolerance	$T_{\text{A}} = 25^{\circ}\text{C}$ , $I_{\text{OUT}} = 0\text{ A}$			$\pm 1.0\%$ <sup>(2)</sup>	
	Temperature variation	$-40^{\circ}\text{C} \leq T_{\text{A}} \leq +85^{\circ}\text{C}$ , $I_{\text{OUT}} = 0\text{ A}$		$\pm 0.3\%$		
	Line regulation	Over $V_{\text{IN}}$ range, $T_{\text{A}} = 25^{\circ}\text{C}$ , $I_{\text{OUT}} = 0\text{ A}$		$\pm 0.1\%$		
	Load regulation	Over $I_{\text{OUT}}$ range, $T_{\text{A}} = 25^{\circ}\text{C}$		$\pm 0.1\%$		
	Total output voltage variation	Includes set-point, line, load, and temperature variation				$\pm 1.5\%$ <sup>(2)</sup>
$\eta$	Efficiency	$V_{\text{IN}} = 5\text{ V}$ $I_{\text{O}} = 2\text{ A}$	$V_{\text{OUT}} = 3.3\text{ V}$ , $f_{\text{SW}} = 1\text{ MHz}$		95%	
			$V_{\text{OUT}} = 2.5\text{ V}$ , $f_{\text{SW}} = 1\text{ MHz}$		93%	
			$V_{\text{OUT}} = 1.8\text{ V}$ , $f_{\text{SW}} = 1\text{ MHz}$		91%	
			$V_{\text{OUT}} = 1.5\text{ V}$ , $f_{\text{SW}} = 1\text{ MHz}$		89%	
			$V_{\text{OUT}} = 1.2\text{ V}$ , $f_{\text{SW}} = 750\text{ kHz}$		87%	
			$V_{\text{OUT}} = 1.0\text{ V}$ , $f_{\text{SW}} = 650\text{ kHz}$		85%	
			$V_{\text{OUT}} = 0.8\text{ V}$ , $f_{\text{SW}} = 650\text{ kHz}$		84%	
		$V_{\text{IN}} = 3.3\text{ V}$ $I_{\text{O}} = 2\text{ A}$	$V_{\text{OUT}} = 1.8\text{ V}$ , $f_{\text{SW}} = 1\text{ MHz}$		90%	
			$V_{\text{OUT}} = 1.5\text{ V}$ , $f_{\text{SW}} = 1\text{ MHz}$		88%	
			$V_{\text{OUT}} = 1.2\text{ V}$ , $f_{\text{SW}} = 750\text{ kHz}$		87%	
			$V_{\text{OUT}} = 1.0\text{ V}$ , $f_{\text{SW}} = 650\text{ kHz}$		84%	
			$V_{\text{OUT}} = 1.0\text{ V}$ , $f_{\text{SW}} = 650\text{ kHz}$		84%	
			$V_{\text{OUT}} = 0.8\text{ V}$ , $f_{\text{SW}} = 650\text{ kHz}$		82%	
	Output voltage ripple	20 MHz bandwidth		9		mV <sub>PP</sub>
$I_{\text{LIM}}$	Overcurrent threshold			7		A
	Transient response	1.0 A/ $\mu\text{s}$ load step from 1A to 3A	Recovery time		80	$\mu\text{s}$
			$V_{\text{OUT}}$ over/undershoot		90	mV
$V_{\text{INH-H}}$	Inhibit Control	Inhibit High Voltage		1.25	Open <sup>(3)</sup>	V
$V_{\text{INH-L}}$		Inhibit Low Voltage	-0.3	1.0		
$I_{\text{I(stby)}}$	Input standby current	INH pin to AGND		70	100	$\mu\text{A}$
Power Good	PWRGD Thresholds	$V_{\text{OUT}}$ rising	Good		93%	
			Fault		107%	
		$V_{\text{OUT}}$ falling	Fault		91%	
			Good		105%	
	PWRGD Low Voltage	$I(\text{PWRGD}) = 0.33\text{ mA}$			0.3	V
$f_{\text{SW}}$	Switching frequency	Over $V_{\text{IN}}$ and $I_{\text{OUT}}$ ranges, RT/CLK pin OPEN	400	500	600	kHz
$f_{\text{CLK}}$	Synchronization frequency		500		2000	kHz
$V_{\text{CLK-H}}$	CLK High-Level Threshold	CLK Control		2.2	3.3	V
$V_{\text{CLK-L}}$	CLK Low-Level Threshold			-0.3	0.4	V
CLK_PW	CLK Pulse Width			75 <sup>(4)</sup>		ns
	Thermal Shutdown	Thermal shutdown		175		$^{\circ}\text{C}$
		Thermal shutdown hysteresis		15		$^{\circ}\text{C}$

- (1) The minimum  $V_{\text{IN}}$  depends on  $V_{\text{OUT}}$  and the switching frequency. Please refer to [Table 7](#) for operating limits.
- (2) The stated limit of the set-point voltage tolerance includes the tolerance of both the internal voltage reference and the internal adjustment resistor. The overall output voltage tolerance will be affected by the tolerance of the external  $R_{\text{SET}}$  resistor.
- (3) This control pin has an internal pullup. Do not place an external pull-up resistor on this pin. If this pin is left open circuit, the device operates when input power is applied. A small low-leakage MOSFET is recommended for control. See the application section for further guidance.
- (4) The maximum synchronization clock pulse width is dependant on  $V_{\text{IN}}$ ,  $V_{\text{OUT}}$ , and the synchronization frequency. See the [Synchronization \(CLK\)](#) section for more information.

### ELECTRICAL CHARACTERISTICS (continued)

Over -40°C to 85°C free-air temperature,  $V_{IN} = 3.3\text{ V}$ ,  $V_{OUT} = 1.8\text{ V}$ ,  $I_{OUT} = 4\text{ A}$ ,  
 $C_{IN1} = 47\text{ }\mu\text{F}$  ceramic,  $C_{IN2} = 220\text{ }\mu\text{F}$  poly-tantalum,  $C_{OUT1} = 47\text{ }\mu\text{F}$  ceramic,  $C_{OUT2} = 100\text{ }\mu\text{F}$  poly-tantalum (unless otherwise noted)

PARAMETER	TEST CONDITIONS	MIN	TYP	MAX	UNIT
$C_{IN}$ External input capacitance	Ceramic	47 <sup>(5)</sup>			$\mu\text{F}$
	Non-ceramic		220 <sup>(5)</sup>		
$C_{OUT}$ External output capacitance	Ceramic	47 <sup>(6)</sup>	150	650 <sup>(7)</sup>	$\mu\text{F}$
	Non-ceramic		100 <sup>(6)</sup>	2000 <sup>(7)</sup>	
	Equivalent series resistance (ESR)				25

- (5) A minimum of 47 $\mu\text{F}$  of ceramic capacitance is required across the input for proper operation. Locate the capacitor close to the device. An additional 220 $\mu\text{F}$  of bulk capacitance is recommended. See Table 5 for more details.
- (6) The amount of required output capacitance varies depending on the output voltage (see Table 3 ). The amount of required capacitance must include at least 47 $\mu\text{F}$  of ceramic capacitance. Locate the capacitance close to the device. Adding additional capacitance close to the load improves the response of the regulator to load transients. See Table 3 and Table 5 for more details.
- (7) When using both ceramic and non-ceramic output capacitance, the combined maximum must not exceed 2200 $\mu\text{F}$ .

### DEVICE INFORMATION

#### FUNCTIONAL BLOCK DIAGRAM

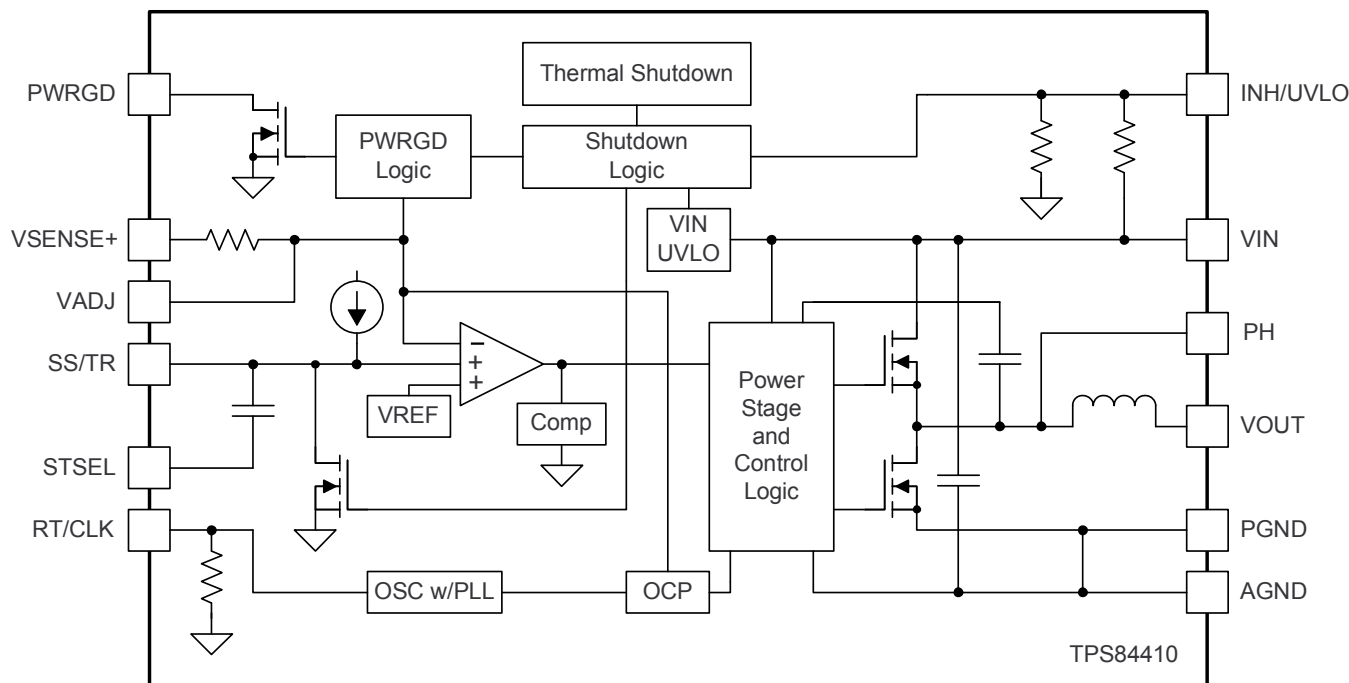

## PIN DESCRIPTIONS

TERMINAL		DESCRIPTION
NAME	NO.	
AGND	1	Zero VDC reference for the analog control circuitry. These pins should be connected directly to the PCB analog ground plane. Not all pins are connected together internally. All pins must be connected together externally with a copper plane or pour directly under the module. Connect the AGND copper area to the PGND copper area at a single point; directly at the pin 37 PowerPAD using multiple vias. See the recommended layout in <a href="#">Figure 34</a> .
	5	
	29	
	33	
	34	
PowerPAD (PGND)	37	This pad provides both an electrical and thermal connection to the PCB. This pad should be connected directly to the PCB power ground plane using multiple vias for good electrical and thermal performance. The same vias should also be used to connect to the PCB analog ground plane. See the recommended layout in <a href="#">Figure 34</a> .
DNC	2	Do not connect. Do not connect these pins to AGND, to another DNC pin, or to any other voltage. These pins are connected to internal circuitry. Each pin must be soldered to an isolated pad.
	3	
	15	
	16	
	26	
INH/UVLO	28	Inhibit and UVLO adjust pin. Use an open drain or open collector output logic to control the INH function. A resistor between this pin and AGND adjusts the UVLO voltage.
PH	17	Phase switch node. These pins should be connected by a small copper island under the device for thermal relief. Do not connect any external component to this pin or tie it to a pin of another function.
	18	
	19	
	20	
	21	
	22	
	23	
	24	
	25	
39		
PWRGD	27	Power good fault pin. Asserts low if the output voltage is out of tolerance. A pull-up resistor is required.
RT/CLK	4	This pin automatically selects between RT mode and CLK mode. An external timing resistor adjusts the switching frequency of the device. In CLK mode, the device synchronizes to an external clock.
SENSE+	36	Remote sense connection. Connect this pin to VOUT at the load for improved regulation. This pin must be connected to VOUT at the load, or at the module pins.
SS/TR	6	Slow-start and tracking pin. Connecting an external capacitor to this pin adjusts the output voltage rise time. A voltage applied to this pin allows for tracking and sequencing control.
STSEL	7	Slow-start or track feature select. Connect this pin to AGND to enable the internal SS capacitor with a SS interval of approximately 1.1 ms. Leave this pin open to enable the TR feature.
VADJ	35	Connecting a resistor between this pin and AGND sets the output voltage above the 0.8V default voltage.
VIN	30	The positive input voltage power pins, which are referenced to PGND. Connect external input capacitance between these pins and the PGND plane, close to the device.
	31	
	32	
VOUT	8	Output voltage. Connect output capacitors between these pins and the PGND plane, close to the device.
	9	
	10	
	11	
	12	
	13	
	14	
38		

RKG PACKAGE  
39 PINS  
(TOP VIEW)

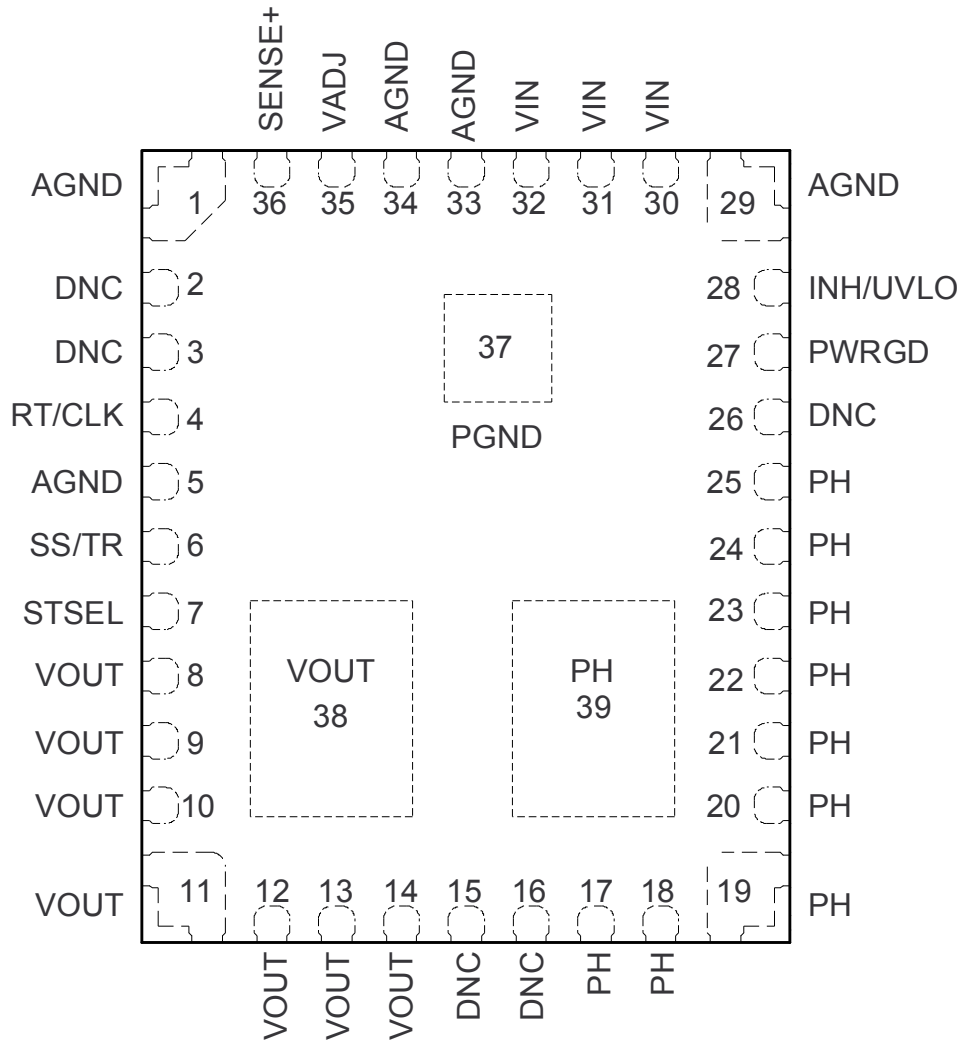

**TYPICAL CHARACTERISTICS (VIN = 5 V)<sup>(1)</sup> <sup>(2)</sup>**

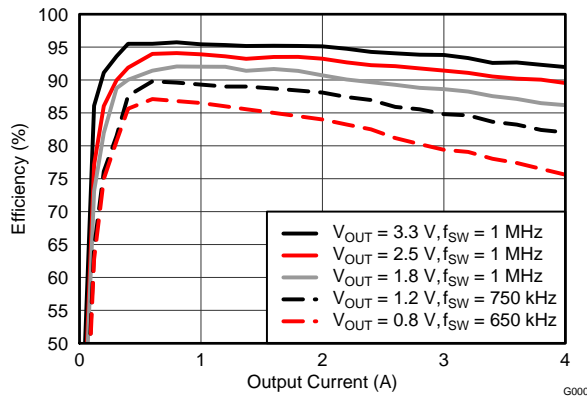

**Figure 1. Efficiency vs. Output Current**

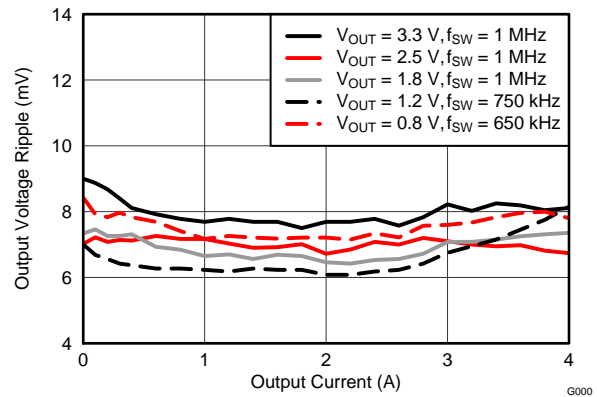

**Figure 2. Voltage Ripple vs. Output Current**

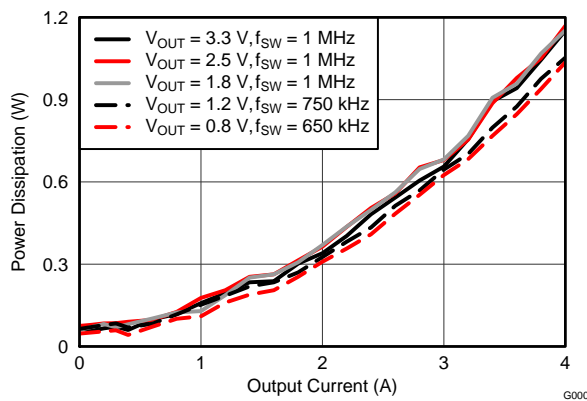

**Figure 3. Power Dissipation vs. Output Current**

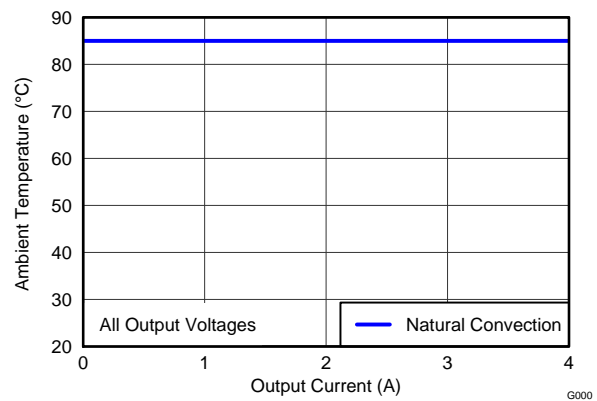

**Figure 4. Safe Operating Area**

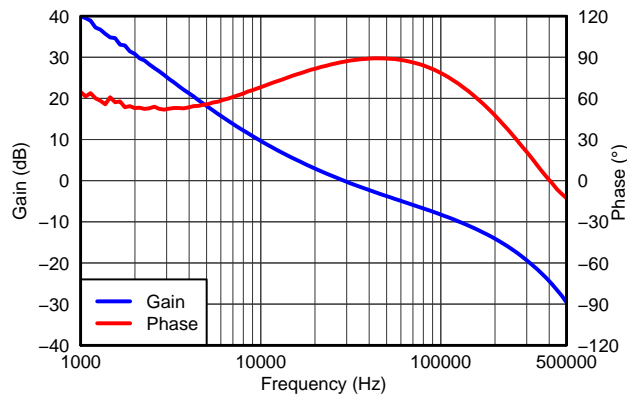

**Figure 5.  $V_{OUT} = 1.8\text{ V}$ ,  $I_{OUT} = 4\text{ A}$ ,  $C_{OUT1} = 47\text{ }\mu\text{F}$  ceramic,  $C_{OUT2} = 100\text{ }\mu\text{F}$  POSCAP,  $f_{SW} = 1\text{ MHz}$**

- (1) The electrical characteristic data has been developed from actual products tested at 25°C. This data is considered typical for the converter. Applies to [Figure 1](#), [Figure 2](#), and [Figure 3](#).
- (2) The temperature derating curves represent the conditions at which internal components are at or below the manufacturer's maximum operating temperatures. Derating limits apply to devices soldered directly to a 100 mm x 100 mm double-sided PCB with 1 oz. copper. Applies to [Figure 4](#).

TYPICAL CHARACTERISTICS (VIN = 3.3 V)<sup>(1) (2)</sup>

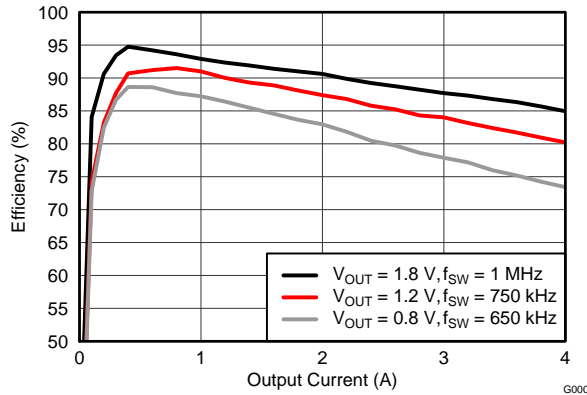

Figure 6. Efficiency vs. Output Current

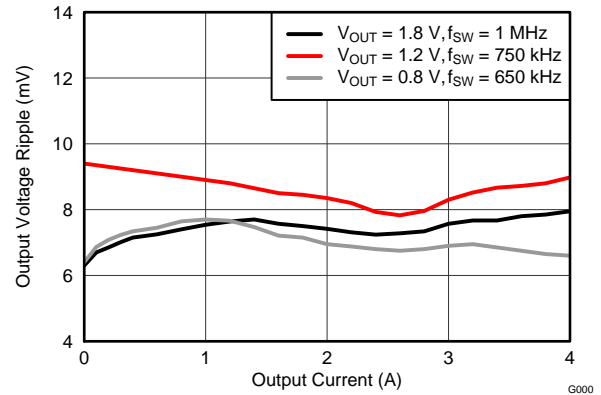

Figure 7. Voltage Ripple vs. Output Current

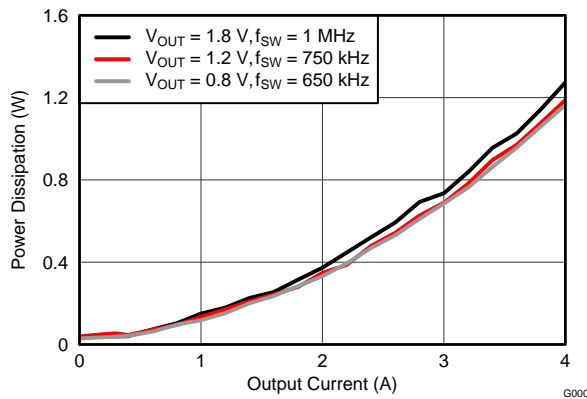

Figure 8. Power Dissipation vs. Output Current

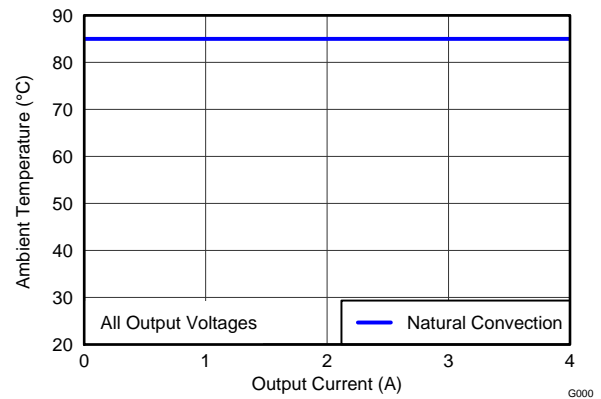

Figure 9. Safe Operating Area

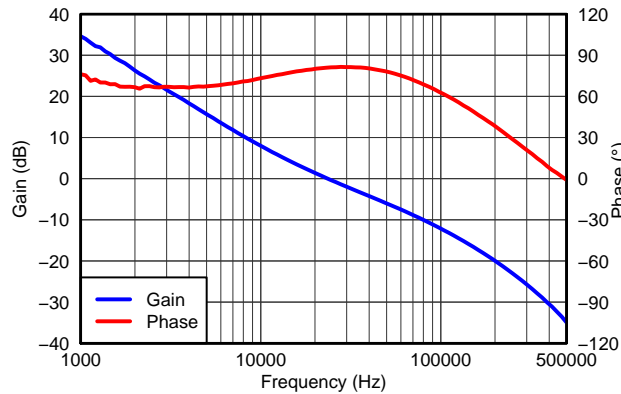

Figure 10. V<sub>OUT</sub> = 1.8 V, I<sub>OUT</sub> = 4 A, C<sub>OUT1</sub> = 47 μF ceramic, C<sub>OUT2</sub> = 100 μF POSCAP, f<sub>SW</sub> = 1 MHz

- (1) The electrical characteristic data has been developed from actual products tested at 25°C. This data is considered typical for the converter. Applies to [Figure 6](#), [Figure 7](#), and [Figure 8](#).
- (2) The temperature derating curves represent the conditions at which internal components are at or below the manufacturer's maximum operating temperatures. Derating limits apply to devices soldered directly to a 100 mm x 100 mm double-sided PCB with 1 oz. copper. Applies to [Figure 9](#).

## APPLICATION INFORMATION

### ADJUSTING THE OUTPUT VOLTAGE

The V<sub>ADJ</sub> control sets the output voltage of the TPS84410. The output voltage adjustment range is from 0.8V to 3.6V. The adjustment method requires the addition of R<sub>SET</sub>, which sets the output voltage, the connection of SENSE+ to V<sub>OUT</sub>, and in some cases R<sub>RT</sub> which sets the switching frequency. The R<sub>SET</sub> resistor must be connected directly between the V<sub>ADJ</sub> (pin 35) and AGND (pin 33 & 34). The SENSE+ pin (pin 36) must be connected to V<sub>OUT</sub> either at the load for improved regulation or at V<sub>OUT</sub> of the module. The R<sub>RT</sub> resistor must be connected directly between the RT/CLK (pin 4) and AGND (pins 33 & 34).

Table 1 gives the standard external R<sub>SET</sub> resistor for a number of common bus voltages, along with the recommended R<sub>RT</sub> resistor for that output voltage.

**Table 1. Standard R<sub>SET</sub> Resistor Values for Common Output Voltages**

RESISTORS	OUTPUT VOLTAGE V <sub>OUT</sub> (V)					
	0.8	1.2	1.5	1.8	2.5	3.3
R <sub>SET</sub> (kΩ)	open	2.87	1.65	1.15	0.673	0.459
R <sub>RT</sub> (kΩ)	1200	715	348	348	348	348

For other output voltages, the value of the required resistor can either be calculated using the following formula, or simply selected from the range of values given in Table 2.

$$R_{SET} = \frac{1.43}{\left(\left(\frac{V_{OUT}}{0.803}\right) - 1\right)} \text{ (k}\Omega\text{)} \quad (1)$$

**Table 2. Standard R<sub>SET</sub> Resistor Values**

V <sub>OUT</sub> (V)	R <sub>SET</sub> (kΩ)	R <sub>RT</sub> (kΩ)	f <sub>sw</sub> (kHz)	V <sub>OUT</sub> (V)	R <sub>SET</sub> (kΩ)	R <sub>RT</sub> (kΩ)	f <sub>sw</sub> (kHz)
0.8	open	1200	650	2.3	0.768	348	1000
0.9	11.8	1200	650	2.4	0.715	348	1000
1.0	5.83	1200	650	2.5	0.673	348	1000
1.1	3.83	1200	650	2.6	0.634	348	1000
1.2	2.87	715	750	2.7	0.604	348	1000
1.3	2.32	715	750	2.8	0.576	348	1000
1.4	1.91	715	750	2.9	0.549	348	1000
1.5	1.65	348	1000	3.0	0.523	348	1000
1.6	1.43	348	1000	3.1	0.499	348	1000
1.7	1.27	348	1000	3.2	0.475	348	1000
1.8	1.15	348	1000	3.3	0.459	348	1000
1.9	1.05	348	1000	3.4	0.442	348	1000
2.0	0.953	348	1000	3.5	0.422	348	1000
2.1	0.845	348	1000	3.6	0.412	348	1000
2.2	0.825	348	1000				

## CAPACITOR RECOMMENDATIONS FOR THE TPS84410 POWER SUPPLY

### Capacitor Technologies

#### *Electrolytic, Polymer-Electrolytic Capacitors*

When using electrolytic capacitors, high-quality, computer-grade electrolytic capacitors are recommended. Polymer-electrolytic type capacitors are recommended for applications where the ambient operating temperature is less than 0°C. The Sanyo OS-CON capacitor series is suggested due to the lower ESR, higher rated surge, power dissipation, ripple current capability, and small package size. Aluminum electrolytic capacitors provide adequate decoupling over the frequency range of 2 kHz to 150 kHz, and are suitable when ambient temperatures are above 0°C.

#### *Ceramic Capacitors*

The performance of aluminum electrolytic capacitors is less effective than ceramic capacitors above 150 kHz. Multilayer ceramic capacitors have a low ESR and a resonant frequency higher than the bandwidth of the regulator. They can be used to reduce the reflected ripple current at the input as well as improve the transient response of the output.

#### *Tantalum, Polymer-Tantalum Capacitors*

Polymer-tantalum type capacitors are recommended for applications where the ambient operating temperature is less than 0°C. The Sanyo POSCAP series and Kemet T530 capacitor series are recommended rather than many other tantalum types due to their lower ESR, higher rated surge, power dissipation, ripple current capability, and small package size. Tantalum capacitors that have no stated ESR or surge current rating are not recommended for power applications.

### Input Capacitor

The TPS84410 requires a minimum input capacitance of 47  $\mu\text{F}$  of ceramic capacitance. An additional 220  $\mu\text{F}$  polymer-tantalum capacitor is recommended for applications with transient load requirements. The combined ripple current rating of the input capacitors must be at least 2000 mArms. [Table 5](#) includes a preferred list of capacitors by vendor. For applications where the ambient operating temperature is less than 0°C, an additional 1  $\mu\text{F}$ , X5R or X7R ceramic capacitor placed between VIN and AGND is recommended.

### Output Capacitor

The required output capacitance is determined by the output voltage of the TPS84410. See [Table 3](#) for the amount of required capacitance. The required output capacitance must include at least one 47  $\mu\text{F}$  ceramic capacitor. For applications where the ambient operating temperature is less than 0°C, an additional 100  $\mu\text{F}$  polymer-tantalum capacitor is recommended. When adding additional non-ceramic bulk capacitors, low-ESR devices like the ones recommended in [Table 5](#) are required. The required capacitance above the minimum is determined by actual transient deviation requirements. See [Table 4](#) for typical transient response values for several output voltage, input voltage and capacitance combinations. [Table 5](#) includes a preferred list of capacitors by vendor.

**Table 3. Required Output Capacitance**

V <sub>OUT</sub> RANGE (V)		MINIMUM REQUIRED C <sub>OUT</sub> ( $\mu\text{F}$ )
MIN	MAX	
0.8	< 1.8	147 <sup>(1)</sup>
1.8	< 3.3	100 <sup>(2)</sup>
3.3	3.6	47 <sup>(2)</sup>

- (1) Minimum required must include at least 1 x 47  $\mu\text{F}$  ceramic capacitor plus 1 x 100  $\mu\text{F}$  polymer-tantalum capacitor.  
 (2) Minimum required must include at least 47  $\mu\text{F}$  of ceramic capacitance.

**Table 4. Output Voltage Transient Response**

$C_{IN1} = 1 \times 47 \mu\text{F CERAMIC}, C_{IN2} = 220 \mu\text{F POLYMER-TANTALUM, LOAD STEP} = 2 \text{ A}, 1 \text{ A}/\mu\text{s}$						
$V_{OUT}$ (V)	$V_{IN}$ (V)	$C_{OUT1}$ Ceramic	$C_{OUT2}$ BULK	VOLTAGE DEVIATION (mV)	PEAK-PEAK (mV)	RECOVERY TIME ( $\mu\text{s}$ )
0.8	3.3	47 $\mu\text{F}$	100 $\mu\text{F}$	50	95	60
		47 $\mu\text{F}$	330 $\mu\text{F}$	45	85	70
	5	47 $\mu\text{F}$	100 $\mu\text{F}$	45	85	50
		47 $\mu\text{F}$	330 $\mu\text{F}$	40	75	65
1.2	3.3	47 $\mu\text{F}$	100 $\mu\text{F}$	70	130	80
		47 $\mu\text{F}$	330 $\mu\text{F}$	55	100	80
	5	47 $\mu\text{F}$	100 $\mu\text{F}$	60	110	65
		47 $\mu\text{F}$	330 $\mu\text{F}$	50	90	80
1.8	3.3	47 $\mu\text{F}$	100 $\mu\text{F}$	95	185	90
		47 $\mu\text{F}$	330 $\mu\text{F}$	75	140	110
	5	47 $\mu\text{F}$	100 $\mu\text{F}$	80	160	70
		47 $\mu\text{F}$	330 $\mu\text{F}$	65	125	90
2.5	5	47 $\mu\text{F}$	100 $\mu\text{F}$	100	200	80
		2x 47 $\mu\text{F}$	-	140	270	90
3.3	5	47 $\mu\text{F}$	100 $\mu\text{F}$	130	255	100
		47 $\mu\text{F}$	-	200	400	120

**Table 5. Recommended Input/Output Capacitors<sup>(1)</sup>**

VENDOR	SERIES	PART NUMBER	CAPACITOR CHARACTERISTICS		
			WORKING VOLTAGE (V)	CAPACITANCE ( $\mu\text{F}$ )	ESR <sup>(2)</sup> (m $\Omega$ )
Murata	X5R	GRM32ER61C476K	16	47	2
TDK	X5R	C3225X5R0J107M	6.3	100	2
Murata	X5R	GRM32ER60J107M	6.3	100	2
TDK	X5R	C3225X5R0J476K	6.3	47	2
Murata	X5R	GRM32ER60J476M	6.3	47	2
Sanyo	POSCAP	10TPE220ML	10	220	25
Kemet	T520	T520V107M010ASE025	10	100	25
Sanyo	POSCAP	6TPE100MPB	6.3	100	25
Sanyo	POSCAP	2R5TPE220M7	2.5	220	7
Kemet	T530	T530D227M006ATE006	6.3	220	6
Kemet	T530	T530D337M006ATE010	6.3	330	10
Sanyo	POSCAP	2TPF330M6	2.0	330	6
Sanyo	POSCAP	6TPE330MFL	6.3	330	15

**(1) Capacitor Supplier Verification**

Please verify availability of capacitors identified in this table.

**RoHS, Lead-free and Material Details**

Please consult capacitor suppliers regarding material composition, RoHS status, lead-free status, and manufacturing process requirements.

**(2) Maximum ESR @ 100kHz, 25°C.**

Transient Response

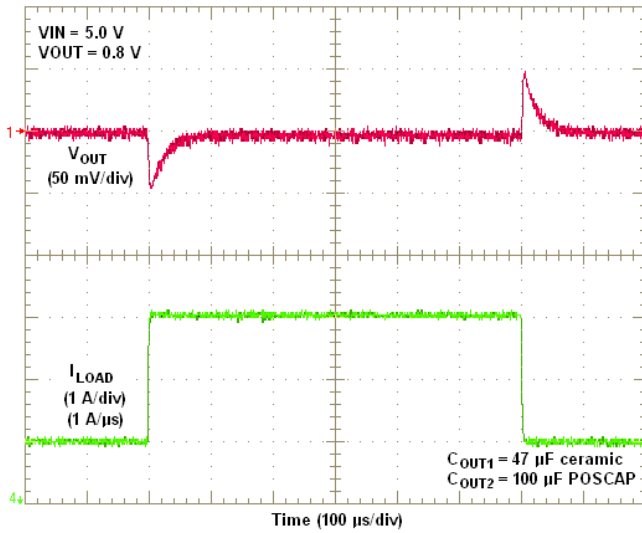

Figure 11. VIN = 5V, VOUT = 0.8V, 2A Load Step

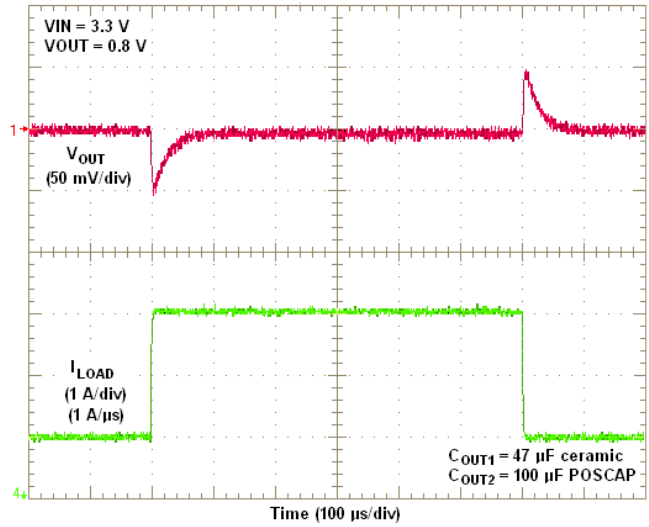

Figure 12. VIN = 3.3V, VOUT = 0.8V, 2A Load Step

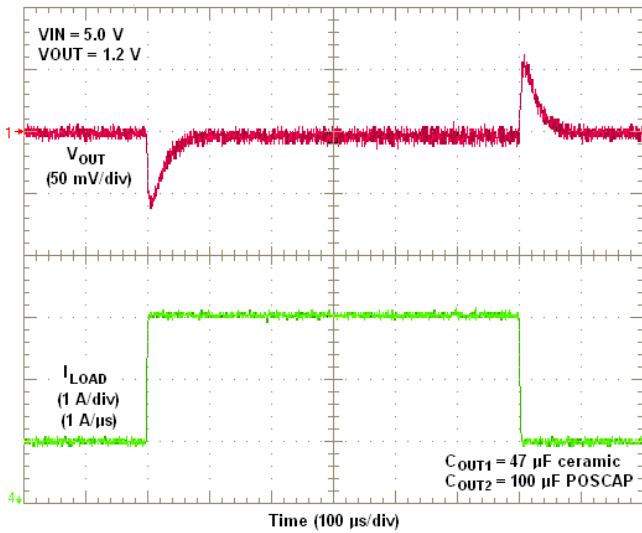

Figure 13. VIN = 5V, VOUT = 1.2V, 2A Load Step

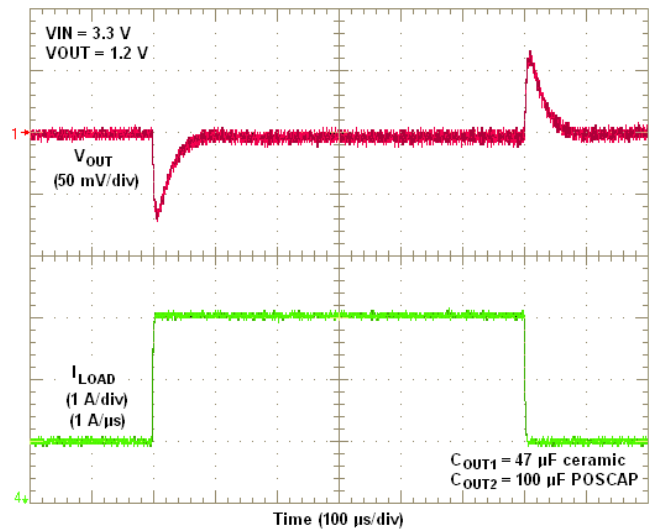

Figure 14. VIN = 3.3V, VOUT = 1.2V, 2A Load Step

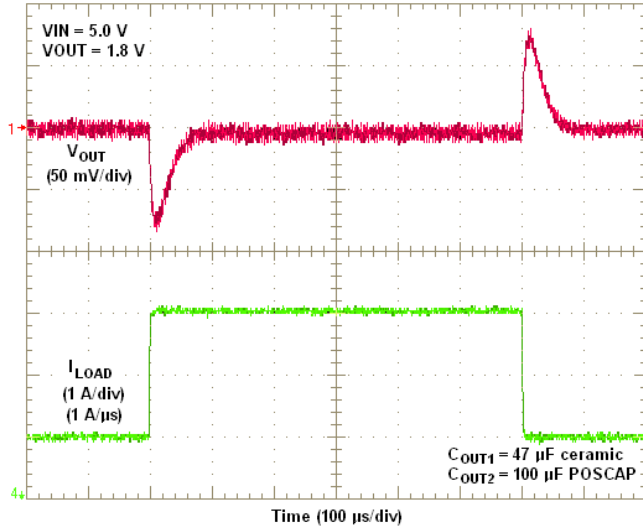

Figure 15. VIN = 5V, VOUT = 1.8V, 2A Load Step

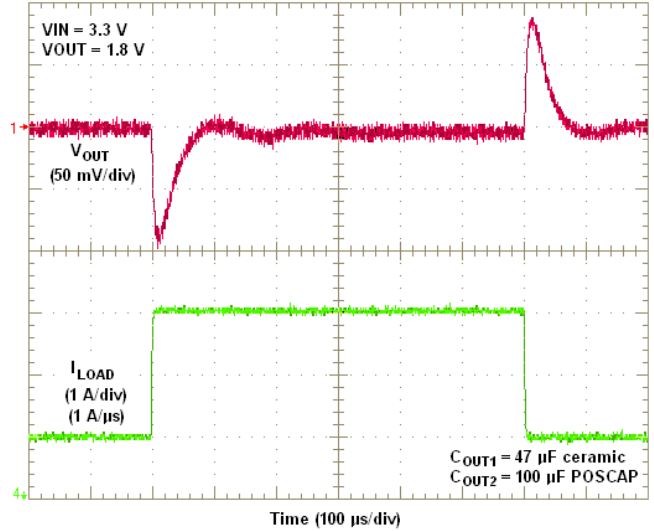

Figure 16. VIN = 3.3V, VOUT = 1.8V, 2A Load Step

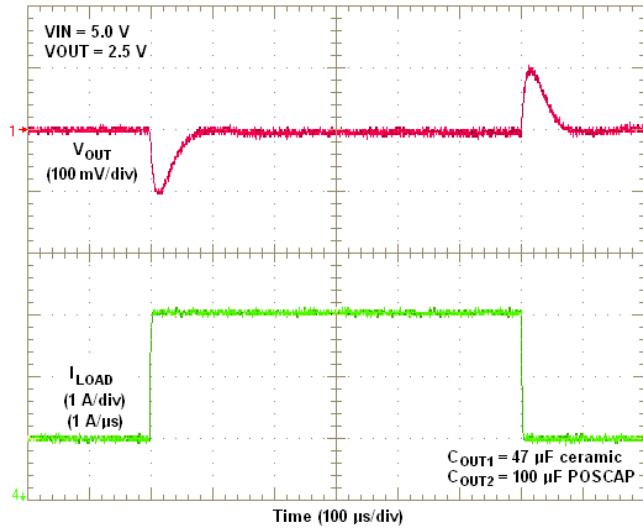

Figure 17. VIN = 5V, VOUT = 2.5V, 2A Load Step

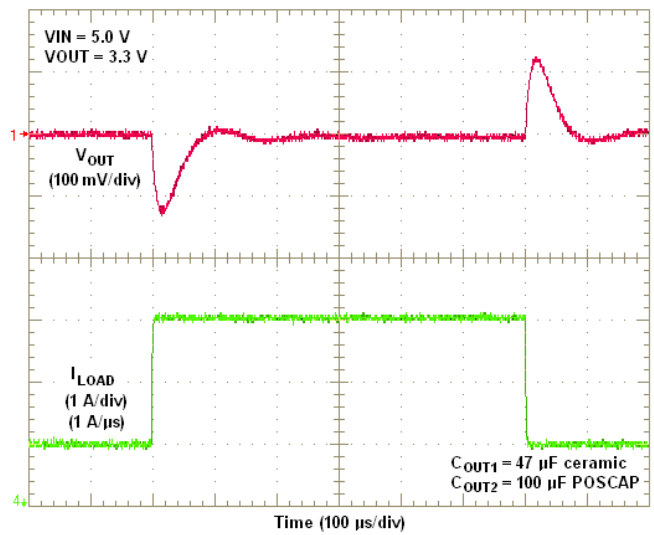
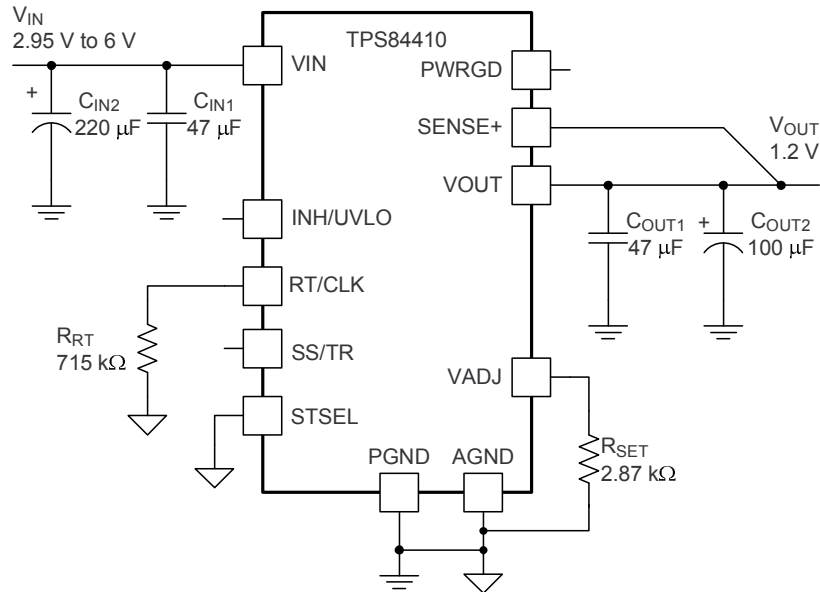
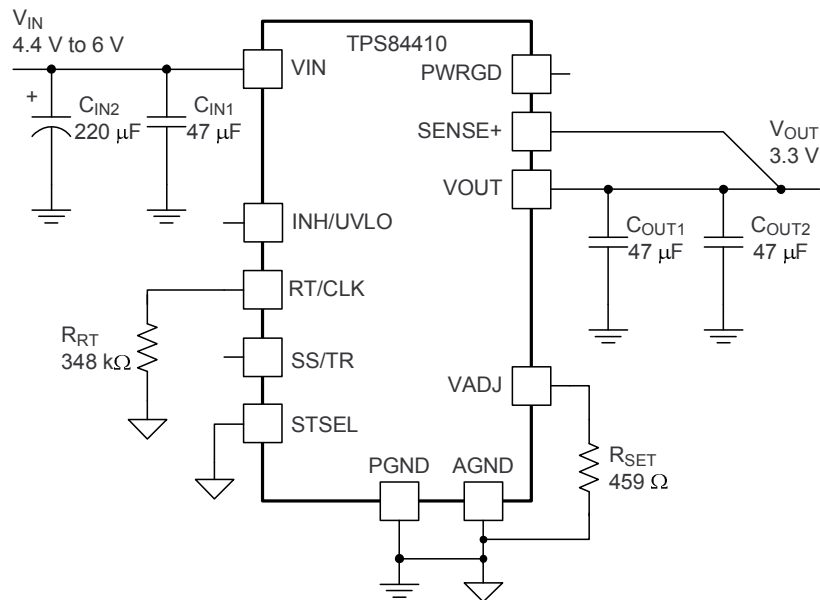

Figure 18. VIN = 5V, VOUT = 3.3V, 2A Load Step

Application Schematics



**Figure 19. Typical Schematic**  
 **$V_{IN} = 2.95\text{ V to }6.0\text{ V}$ ,  $V_{OUT} = 1.2\text{ V}$**



**Figure 20. Typical Schematic**  
 **$V_{IN} = 4.4\text{ V to }6.0\text{ V}$ ,  $V_{OUT} = 3.3\text{ V}$**

## Power Good (PWRGD)

The PWRGD pin is an open drain output. Once the voltage on the SENSE+ pin is between 93% and 105% of the set voltage, the PWRGD pin pull-down is released and the pin floats. The recommended pull-up resistor value is between 10 k $\Omega$  and 100 k $\Omega$  to a voltage source that is 6 V or less. The PWRGD pin is in a defined state once VIN is greater than 1.2 V, but with reduced current sinking capability. The PWRGD pin achieves full current sinking capability once the VIN pin is above 2.95V. Figure 21 shows the PWRGD waveform during power-up. The PWRGD pin is pulled low when the voltage on SENSE+ is lower than 91% or greater than 107% of the nominal set voltage. Also, the PWRGD pin is pulled low if the input UVLO or thermal shutdown is asserted, or if the INH pin is pulled low.

## Power-Up Characteristics

When configured as shown in the front page schematic, the TPS84410 produces a regulated output voltage following the application of a valid input voltage. During the power-up, internal soft-start circuitry slows the rate that the output voltage rises, thereby limiting the amount of in-rush current that can be drawn from the input source. The soft-start circuitry introduces a short time delay from the point that a valid input voltage is recognized. Figure 21 shows the start-up waveforms for a TPS84410, operating from a 5-V input and with the output voltage adjusted to 1.8 V. The waveform is measured with a 2-A constant current load.

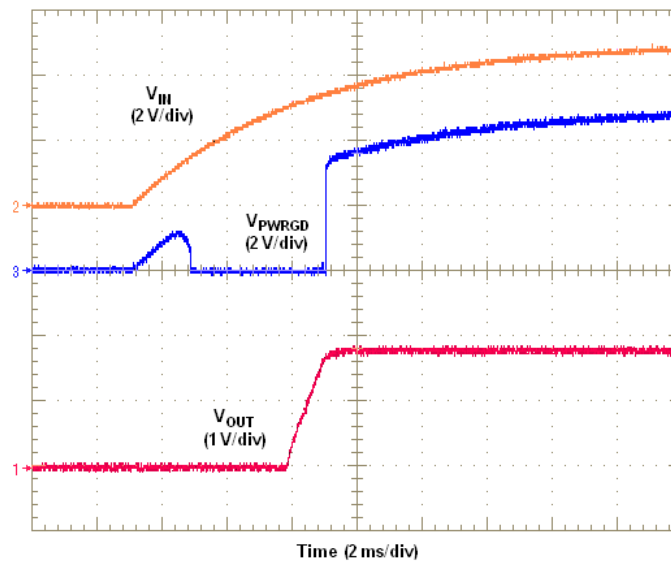

Figure 21. Start-Up Waveforms

## Remote Sense

The SENSE+ pin must be connected to  $V_{OUT}$  at the load, or at the device pins.

Connecting the SENSE+ pin to  $V_{OUT}$  at the load improves the load regulation performance of the device by allowing it to compensate for any I-R voltage drop between its output pins and the load. An I-R drop is caused by the high output current flowing through the small amount of pin and trace resistance. This should be limited to a maximum of 300 mV.

### NOTE

The remote sense feature is not designed to compensate for the forward drop of nonlinear or frequency dependent components that may be placed in series with the converter output. Examples include OR-ing diodes, filter inductors, ferrite beads, and fuses. When these components are enclosed by the SENSE+ connection, they are effectively placed inside the regulation control loop, which can adversely affect the stability of the regulator.

## Output On/Off Inhibit (INH)

The INH pin provides electrical on/off control of the device. Once the INH pin voltage exceeds the threshold voltage, the device starts operation. If the INH pin voltage is pulled below the threshold voltage, the regulator stops switching and enters low quiescent current state.

The INH pin has an internal pull-up current source, allowing the user to float the INH pin for enabling the device. If an application requires controlling the INH pin, use an open drain/collector device, or a suitable logic gate to interface with the pin. Do not place an external pull-up resistor on this pin. Figure 22 shows the typical application of the inhibit function.

Turning Q1 on applies a low voltage to the inhibit control (INH) pin and disables the output of the supply, as shown in Figure 23. If Q1 is turned off, the supply executes a soft-start power-up sequence, as shown in Figure 24. The waveforms were measured with a 2-A constant current load.

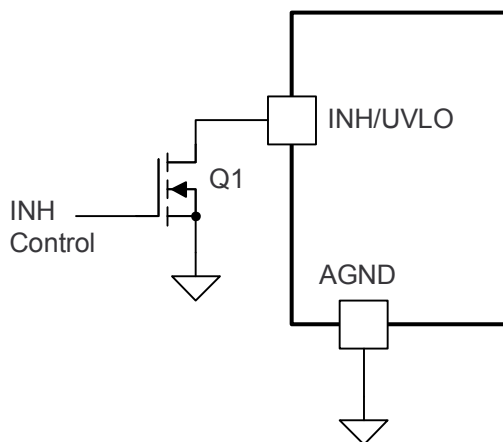

Figure 22. Typical Inhibit Control

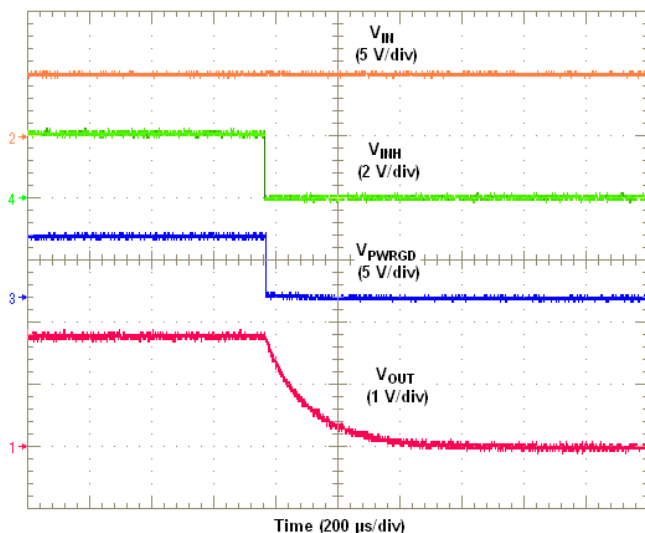

Figure 23. Inhibit Turn-Off

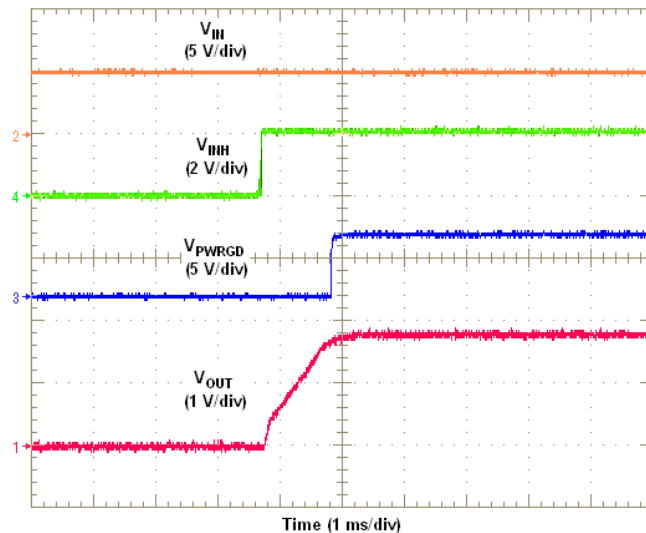

Figure 24. Inhibit Turn-On

### Slow Start (SS/TR)

Connecting the STSEL pin to AGND and leaving SS/TR pin open enables the internal SS capacitor with a slow start interval of approximately 1.1 ms. Adding additional capacitance between the SS pin and AGND increases the slow start time. Table 6 shows an additional SS capacitor connected to the SS/TR pin and the STSEL pin connected to AGND. See Table 6 below for SS capacitor values and timing interval.

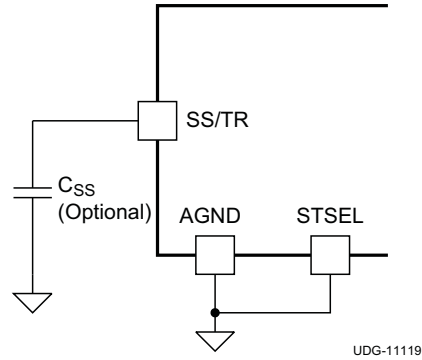

Figure 25. Slow-Start Capacitor (C<sub>SS</sub>) and STSEL Connection

Table 6. Slow-Start Capacitor Values and Slow-Start Time

C <sub>SS</sub> (pF)	open	2200	4700	10000	15000	22000	25000
SS Time (msec)	1.1	1.9	2.8	4.6	6.4	8.8	9.8

### Overcurrent Protection

For protection against load faults, the TPS84410 uses current limiting. The device is protected from overcurrent conditions by cycle-by-cycle current limiting and frequency foldback. During an overcurrent condition the output current is limited and the output voltage is reduced, as shown in Figure 26. When the overcurrent condition is removed, the output voltage returns to the established voltage, as shown in Figure 27.

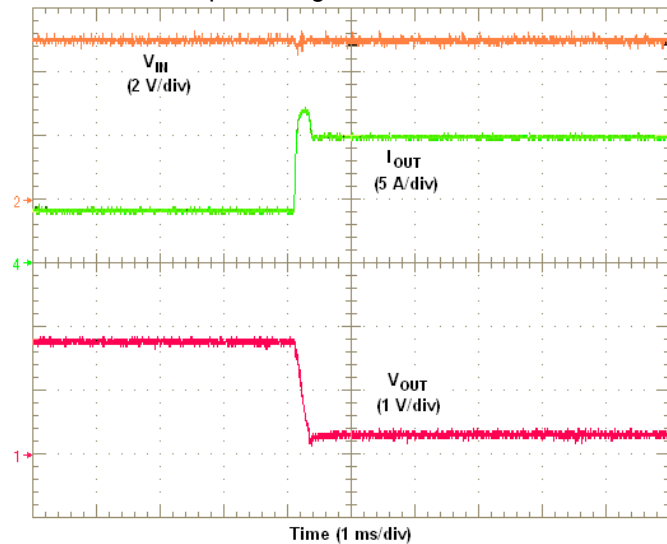

Figure 26. Overcurrent Limiting

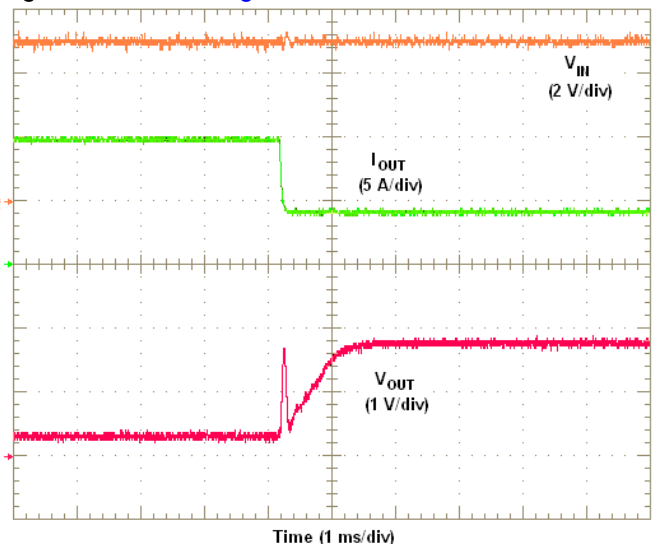

Figure 27. Removal of Overcurrent Condition

## Synchronization (CLK)

An internal phase locked loop (PLL) has been implemented to allow synchronization between 500 kHz and 2 MHz, and to easily switch from RT mode to CLK mode. To implement the synchronization feature, connect a square wave clock signal to the RT/CLK pin with a minimum pulse width of 75 ns. The maximum clock pulse width must be calculated using Equation 2. The clock signal amplitude must transition lower than 0.4 V and higher than 2.2 V. The start of the switching cycle is synchronized to the falling edge of RT/CLK pin. In applications where both RT mode and CLK mode are needed, the device can be configured as shown in Figure 28.

Before the external clock is present, the device works in RT mode and the switching frequency is set by RT resistor ( $R_{RT}$ ). When the external clock is present, the CLK mode overrides the RT mode. The device switches from RT mode to CLK mode and the RT/CLK pin becomes high impedance as the PLL starts to lock onto the frequency of the external clock. The device will lock to the external clock frequency approximately 15  $\mu$ s after a valid clock signal is present. It is not recommended to switch from CLK mode back to RT mode because the internal switching frequency drops to a lower frequency before returning to the switching frequency set by the RT resistor.

$$CLK\_PW_{MAX} = \frac{0.75 \times \left( 1 - \frac{V_{OUT}}{V_{IN(min)}} \right)}{f_{SW}} \quad (2)$$

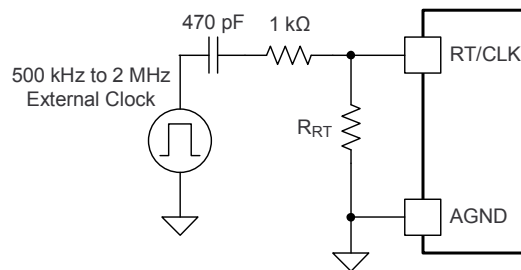

Figure 28. CLK/RT Configuration

The synchronization frequency must be selected based on the output voltages of the devices being synchronized. Table 7 shows the allowable frequencies for a given range of output voltages based on a resistive load. 5V input applications requiring 3.5A or less can synchronize to a wider frequency range. For the most efficient solution, always synchronize to the lowest allowable frequency. For example, an application requires synchronizing three TPS84410 devices with output voltages of 1.2V@3.7A, 1.8@2.5AV and 3.3V@ 2.1A, all powered from  $V_{IN} = 5V$ . Table 7 shows that all three output voltages can be synchronized to any frequency between 750 kHz to 1 MHz. For best efficiency, choose 750 kHz as the synchronization frequency.

Table 7. Synchronization Frequency vs Output Voltage

SYNCHRONIZATION FREQUENCY (kHz)	$R_{RT}$ (k $\Omega$ )	$V_{IN} = 5 V$				$V_{IN} = 3.3 V$	
		$I_{OUT} \leq 3.5 A$		$I_{OUT} > 3.5 A$		All $I_{OUT}$	
		$V_{OUT}$ RANGE (V)		$V_{OUT}$ RANGE (V)		$V_{OUT}$ RANGE (V)	
		MIN	MAX	MIN	MAX	MIN	MAX
500	open	0.8	1.4	0.8	1.0	0.8	2.2
550	3400	0.8	1.6	0.8	1.1	0.8	2.4
600	1800	0.8	1.8	0.8	1.2	0.8	2.5
650	1200	0.8	2.1	0.8	1.4	0.8	2.5
700	887	0.8	2.6	0.8	1.6	0.8	2.5
750	715	0.9	3.6	0.9	1.8	0.8	2.5
800	590	0.9	3.6	0.9	2.1	0.8	2.5
900	511	1.0	3.6	1.0	3.6	0.8	2.5
1000	348	1.2	3.6	1.2	3.6	0.8	2.4
1250	232	1.4	3.6	1.4	3.6	1.0	2.4
1500	174	1.7	3.6	1.7	3.6	1.1	2.3
1750	137	2.0	3.6	2.0	3.6	1.3	2.2
2000	113	2.3	3.4	2.3	3.3	1.5	2.2

### Sequencing (SS/TR)

Many of the common power supply sequencing methods can be implemented using the SS/TR, INH and PWRGD pins. The sequential method is illustrated in Figure 29 using two TPS84410 devices. The PWRGD pin of the first device is coupled to the INH pin of the second device which enables the second power supply once the primary supply reaches regulation. Do not place a pull-up resistor on PWRGD in this configuration. Figure 30 shows sequential turn-on waveforms of two TPS84410 devices.

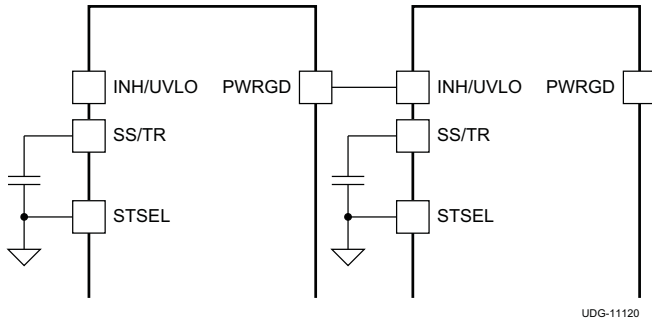

UDG-11120

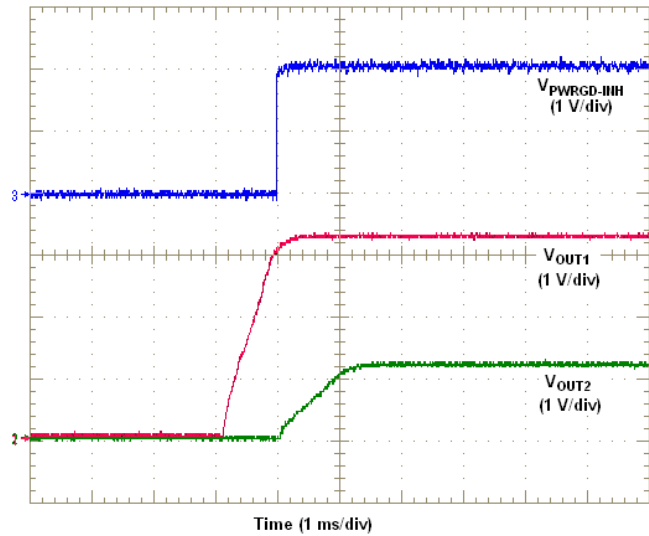

Figure 29. Sequencing Schematic

Figure 30. Sequencing Waveforms

Simultaneous power supply sequencing can be implemented by connecting the resistor network of R1 and R2 shown in Figure 31 to the output of the power supply that needs to be tracked or to another voltage reference source. Figure 32 shows simultaneous turn-on waveforms of two TPS84410 devices. Use Equation 3 and Equation 4 to calculate the values of R1 and R2.

$$R1 = \frac{(V_{OUT2} \times 12.6)}{0.803} \text{ (k}\Omega\text{)}$$

$$(3) \quad R2 = \frac{0.803 \times R1}{(V_{OUT2} - 0.803)} \text{ (k}\Omega\text{)} \quad (4)$$

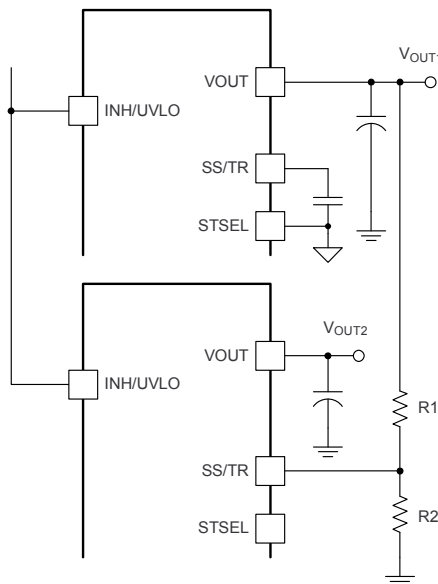

Figure 31. Simultaneous Tracking Schematic

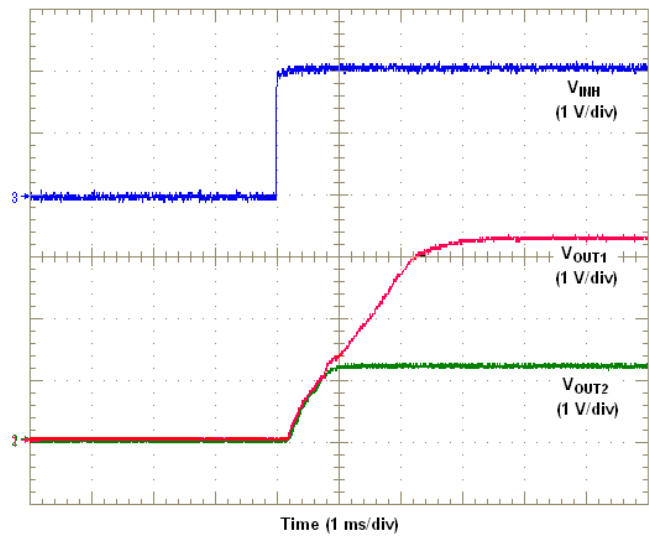
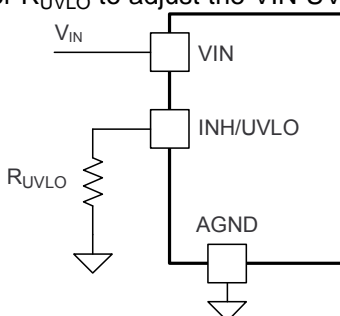

Figure 32. Simultaneous Tracking Waveforms

### Programmable Undervoltage Lockout (UVLO)

The TPS84410 implements internal UVLO circuitry on the VIN pin. The device is disabled when the VIN pin voltage falls below the internal VIN UVLO threshold. The internal VIN UVLO rising threshold is 3.135 V (max) with a typical hysteresis of 300 mV.

If an application requires a higher UVLO threshold on the VIN pin, the UVLO pin can be configured as shown in [Figure 33](#). [Table 8](#) lists standard values for  $R_{UVLO}$  to adjust the VIN UVLO voltage up.



**Figure 33. Adjustable VIN UVLO**

**Table 8. Standard Resistor values for Adjusting VIN UVLO**

VIN UVLO (V) (typ)	3.25	3.5	3.75	4.0	4.25	4.5	4.75
$R_{UVLO}$ (k $\Omega$ )	294	133	86.6	63.4	49.9	42.2	35.7
Hysteresis (mV)	325	335	345	355	365	375	385

## Thermal Shutdown

The internal thermal shutdown circuitry forces the device to stop switching if the junction temperature exceeds 175°C typically. The device reinitiates the power up sequence when the junction temperature drops below 160°C typically.

## Layout Considerations

To achieve optimal electrical and thermal performance, an optimized PCB layout is required. Figure 34, shows a typical PCB layout. Some considerations for an optimized layout are:

- Use large copper areas for power planes (VIN, VOUT, and PGND) to minimize conduction loss and thermal stress.
- Place ceramic input and output capacitors close to the module pins to minimize high frequency noise.
- Locate additional output capacitors between the ceramic capacitor and the load.
- Place a dedicated AGND copper area beneath the TPS84410.
- Connect the AGND and PGND copper area at one point; directly at the pin 37 PowerPad using multiple vias.
- Place  $R_{SET}$ ,  $R_{RT}$ , and  $C_{SS}$  as close as possible to their respective pins.
- Use multiple vias to connect the power planes to internal layers.

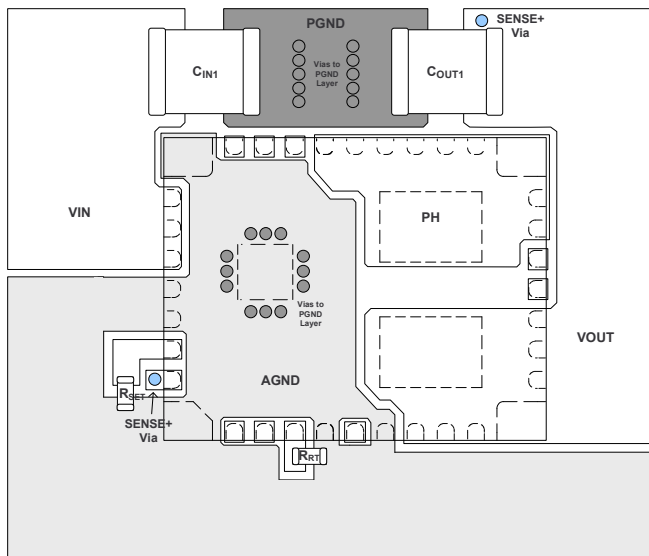

Figure 34. Typical Top-Layer Recommended Layout

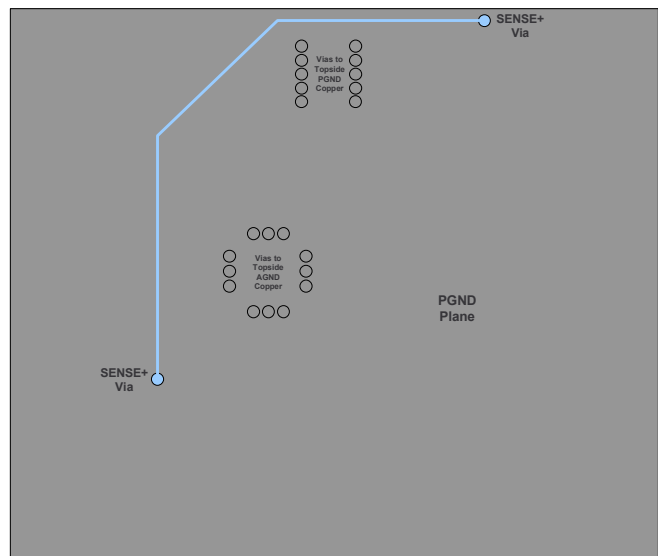
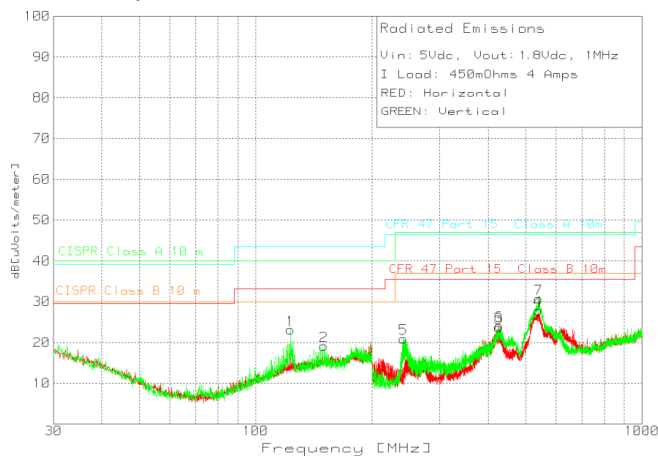

Figure 35. Typical PGND-Layer Recommended Layout

## EMI

The TPS84410 is compliant with EN55022 Class B radiated emissions. [Figure 36](#) and [Figure 37](#) show typical examples of radiated emissions plots for the TPS84410 operating from 5V and 3.3V respectively. Both graphs include the plots of the antenna in the horizontal and vertical positions.



**Figure 36. Radiated Emissions 5-V Input, 1.8-V Output, 4-A Load (EN55022 Class B)**

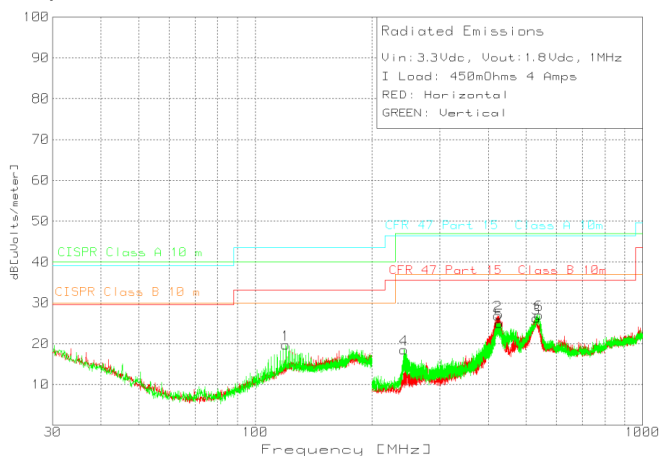

**Figure 37. Radiated Emissions 3.3-V Input, 1.8-V Output, 4-A Load (EN55022 Class B)**

---

**Changes from Original (2011) to Revision A**

**Page**

- 
- Changed the voltage range values in [Table 7](#) ..... 19
-



RKG (S-PB1QFN-N39)

PLASTIC QUAD FLATPACK NO-LEAD

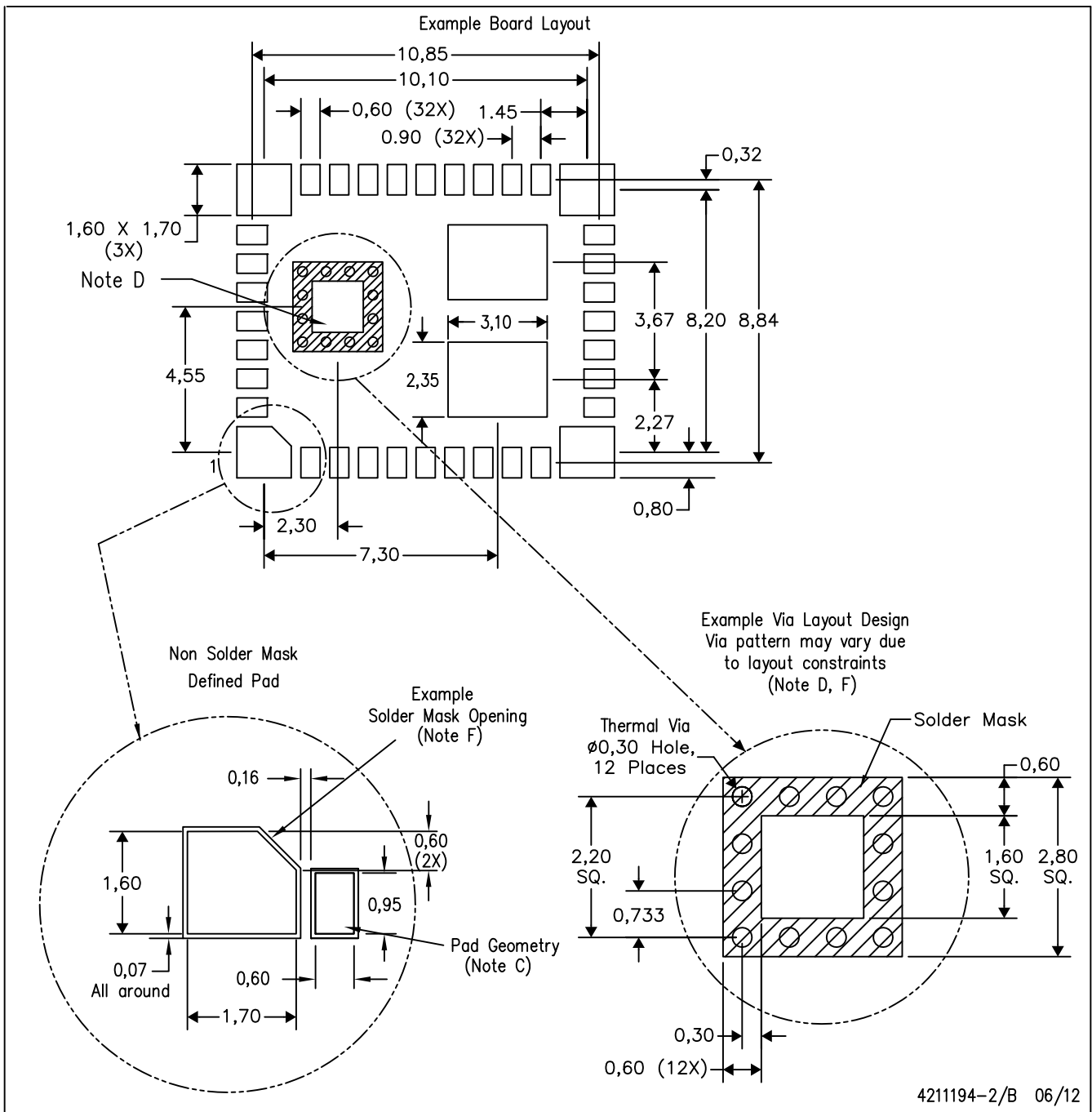

- NOTES:
- All linear dimensions are in millimeters.
  - This drawing is subject to change without notice.
  - Publication IPC-7351 is recommended for alternate designs.
  - This package is designed to be soldered to a thermal pad on the board. Refer to Application Note, Quad Flat-Pack Packages, Texas Instruments Literature No. SLUA271, and also the Product Data Sheets for specific thermal information, via requirements, and recommended board layout. These documents are available at [www.ti.com](http://www.ti.com) <<http://www.ti.com>>.
  - Laser cutting apertures with trapezoidal walls and also rounding corners will offer better paste release. Customers should contact their board assembly site for stencil design recommendations. Refer to IPC 7525 for stencil design considerations.
  - Customers should contact their board fabrication site for minimum solder mask web tolerances between signal pads.

RKG (S-PB1QFN-N39)

PLASTIC QUAD FLATPACK NO-LEAD

Example Stencil Design (Note E)  
Stencil Thickness = 0,125mm

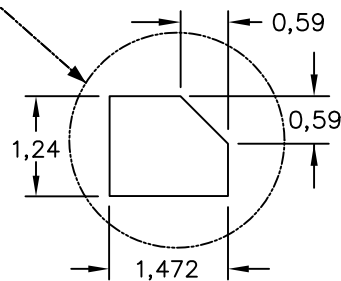
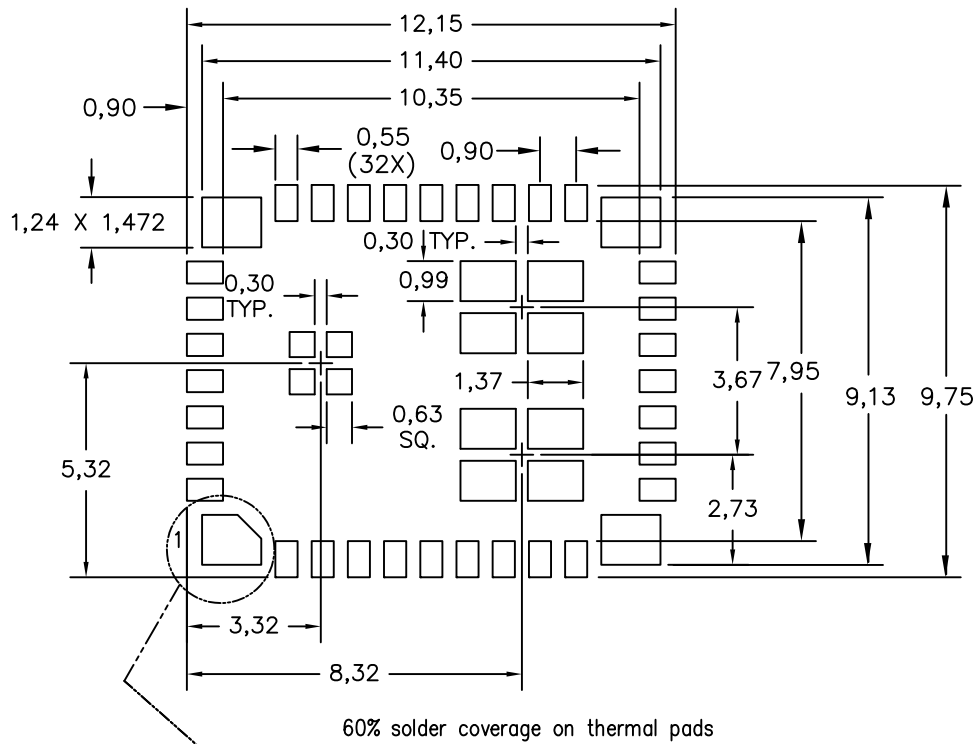

4211194-3/B 06/12

- NOTES:
- A. All linear dimensions are in millimeters.
  - B. This drawing is subject to change without notice.
  - C. Publication IPC-7351 is recommended for alternate designs.
  - D. This package is designed to be soldered to a thermal pad on the board. Refer to Application Note, Quad Flat-Pack Packages, Texas Instruments Literature No. SLUA271, and also the Product Data Sheets for specific thermal information, via requirements, and recommended board layout. These documents are available at [www.ti.com](http://www.ti.com) <<http://www.ti.com>>.
  - E. Laser cutting apertures with trapezoidal walls and also rounding corners will offer better paste release. Customers should contact their board assembly site for stencil design recommendations. Refer to IPC 7525 for stencil design considerations.
  - F. Customers should contact their board fabrication site for minimum solder mask web tolerances between signal pads.

**PACKAGING INFORMATION**

Orderable Device	Status (1)	Package Type	Package Drawing	Pins	Package Qty	Eco Plan (2)	Lead/Ball Finish (6)	MSL Peak Temp (3)	Op Temp (°C)	Device Marking (4/5)	Samples
TPS84410RKGR	ACTIVE	B1QFN	RKG	39	500	Green (RoHS & no Sb/Br)	CU NIPDAU	Level-3-260C-168 HR	-40 to 85	(54418 ~ TPS84410)	<a href="#">Samples</a>
TPS84410RKG T	ACTIVE	B1QFN	RKG	39	250	Green (RoHS & no Sb/Br)	CU NIPDAU	Level-3-260C-168 HR	-40 to 85	(54418 ~ TPS84410)	<a href="#">Samples</a>

(1) The marketing status values are defined as follows:

**ACTIVE:** Product device recommended for new designs.

**LIFEBUY:** TI has announced that the device will be discontinued, and a lifetime-buy period is in effect.

**NRND:** Not recommended for new designs. Device is in production to support existing customers, but TI does not recommend using this part in a new design.

**PREVIEW:** Device has been announced but is not in production. Samples may or may not be available.

**OBSELETE:** TI has discontinued the production of the device.

(2) Eco Plan - The planned eco-friendly classification: Pb-Free (RoHS), Pb-Free (RoHS Exempt), or Green (RoHS & no Sb/Br) - please check <http://www.ti.com/productcontent> for the latest availability information and additional product content details.

**TBD:** The Pb-Free/Green conversion plan has not been defined.

**Pb-Free (RoHS):** TI's terms "Lead-Free" or "Pb-Free" mean semiconductor products that are compatible with the current RoHS requirements for all 6 substances, including the requirement that lead not exceed 0.1% by weight in homogeneous materials. Where designed to be soldered at high temperatures, TI Pb-Free products are suitable for use in specified lead-free processes.

**Pb-Free (RoHS Exempt):** This component has a RoHS exemption for either 1) lead-based flip-chip solder bumps used between the die and package, or 2) lead-based die adhesive used between the die and leadframe. The component is otherwise considered Pb-Free (RoHS compatible) as defined above.

**Green (RoHS & no Sb/Br):** TI defines "Green" to mean Pb-Free (RoHS compatible), and free of Bromine (Br) and Antimony (Sb) based flame retardants (Br or Sb do not exceed 0.1% by weight in homogeneous material)

(3) MSL, Peak Temp. - The Moisture Sensitivity Level rating according to the JEDEC industry standard classifications, and peak solder temperature.

(4) There may be additional marking, which relates to the logo, the lot trace code information, or the environmental category on the device.

(5) Multiple Device Markings will be inside parentheses. Only one Device Marking contained in parentheses and separated by a "~" will appear on a device. If a line is indented then it is a continuation of the previous line and the two combined represent the entire Device Marking for that device.

(6) Lead/Ball Finish - Orderable Devices may have multiple material finish options. Finish options are separated by a vertical ruled line. Lead/Ball Finish values may wrap to two lines if the finish value exceeds the maximum column width.

**Important Information and Disclaimer:** The information provided on this page represents TI's knowledge and belief as of the date that it is provided. TI bases its knowledge and belief on information provided by third parties, and makes no representation or warranty as to the accuracy of such information. Efforts are underway to better integrate information from third parties. TI has taken and continues to take reasonable steps to provide representative and accurate information but may not have conducted destructive testing or chemical analysis on incoming materials and chemicals. TI and TI suppliers consider certain information to be proprietary, and thus CAS numbers and other limited information may not be available for release.

In no event shall TI's liability arising out of such information exceed the total purchase price of the TI part(s) at issue in this document sold by TI to Customer on an annual basis.

# MECHANICAL DATA

RKG (R-PB1QFN-N39)

PLASTIC QUAD FLATPACK NO-LEAD

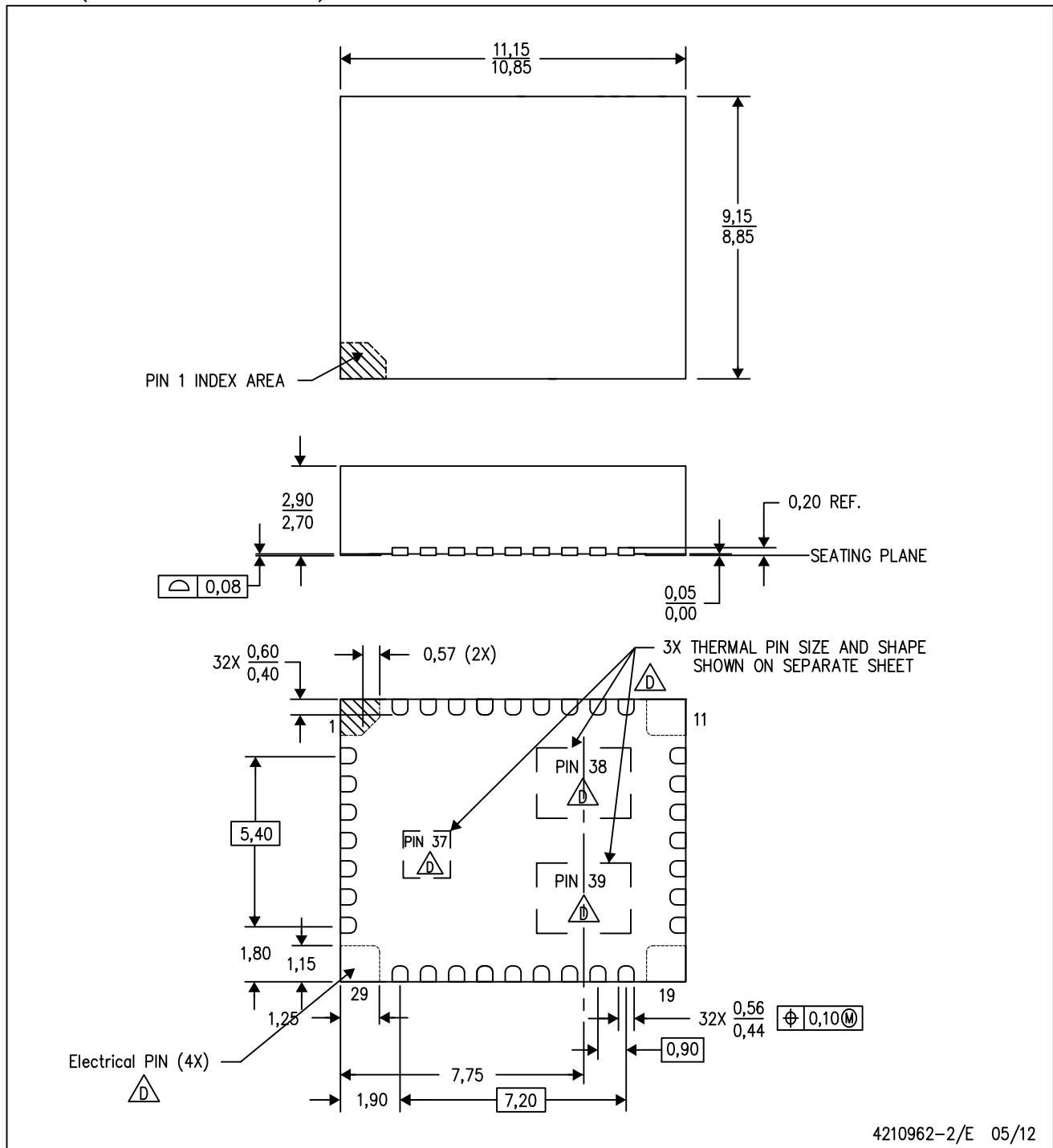

4210962-2/E 05/12

- NOTES:
- A. All linear dimensions are in millimeters. Dimensioning and tolerancing per ASME Y14.5M-1994.
  - B. This drawing is subject to change without notice.
  - C. Quad Flatpack, No-leads (QFN) package configuration.
  -  D. The package thermal pad must be soldered to the board for thermal and mechanical performance.
  - E. See the additional figure in the Product Data Sheet for details regarding the exposed thermal pad features and dimensions.
  -  F. The package thermal performance may be enhanced by bonding the thermal pad to an external thermal plane.

# THERMAL PAD MECHANICAL DATA

RKG (R-PQFN-N39)

PLASTIC QUAD FLATPACK NO-LEAD

## THERMAL INFORMATION

This package incorporates an exposed thermal pad that is designed to be attached directly to an external heatsink. The thermal pad must be soldered directly to the printed circuit board (PCB). After soldering, the PCB can be used as a heatsink. In addition, through the use of thermal vias, the thermal pad can be attached directly to the appropriate copper plane shown in the electrical schematic for the device, or alternatively, can be attached to a special heatsink structure designed into the PCB. This design optimizes the heat transfer from the integrated circuit (IC).

For information on the Quad Flatpack No-Lead (QFN) package and its advantages, refer to Application Report, QFN/SON PCB Attachment, Texas Instruments Literature No. SLUA271. This document is available at [www.ti.com](http://www.ti.com).

The exposed thermal pad dimensions for this package are shown in the following illustration.

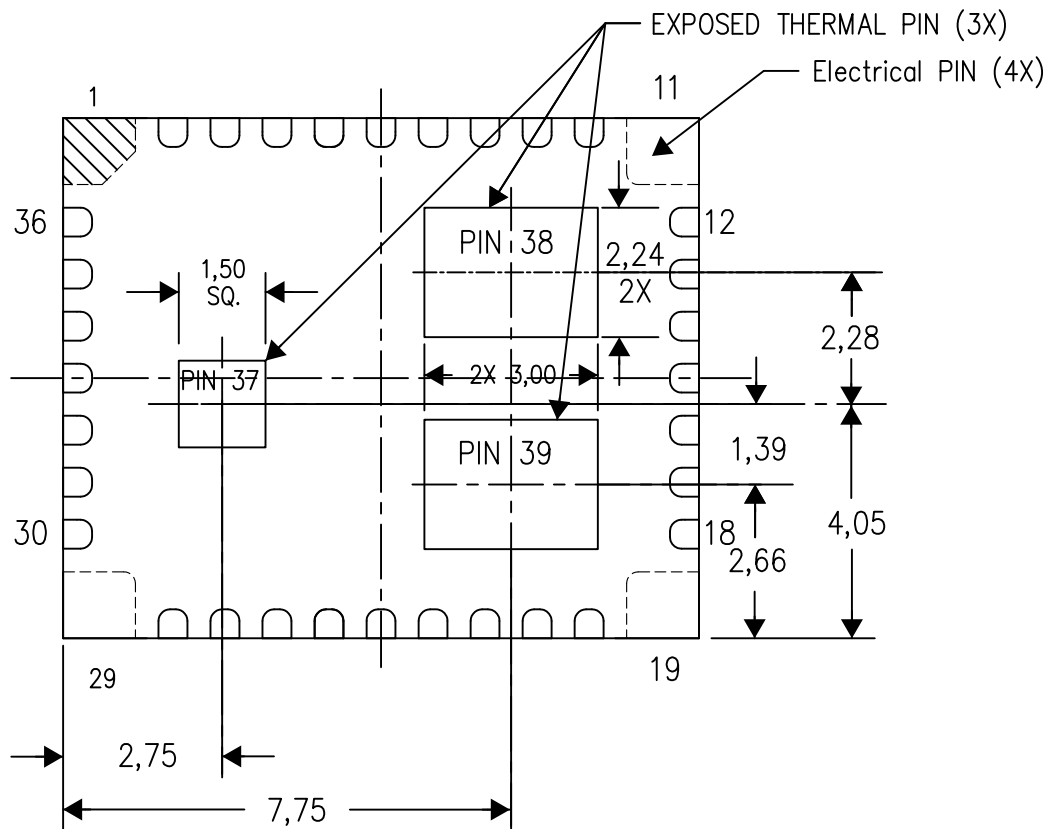

Bottom View

Exposed Thermal Pad Dimensions  
Thermal Pad Tolerance:  $\pm 0.10\text{mm}$

4211170-2/D 01/15

NOTE: A. All linear dimensions are in millimeters

RKG (S-PB1QFN-N39)

PLASTIC QUAD FLATPACK NO-LEAD

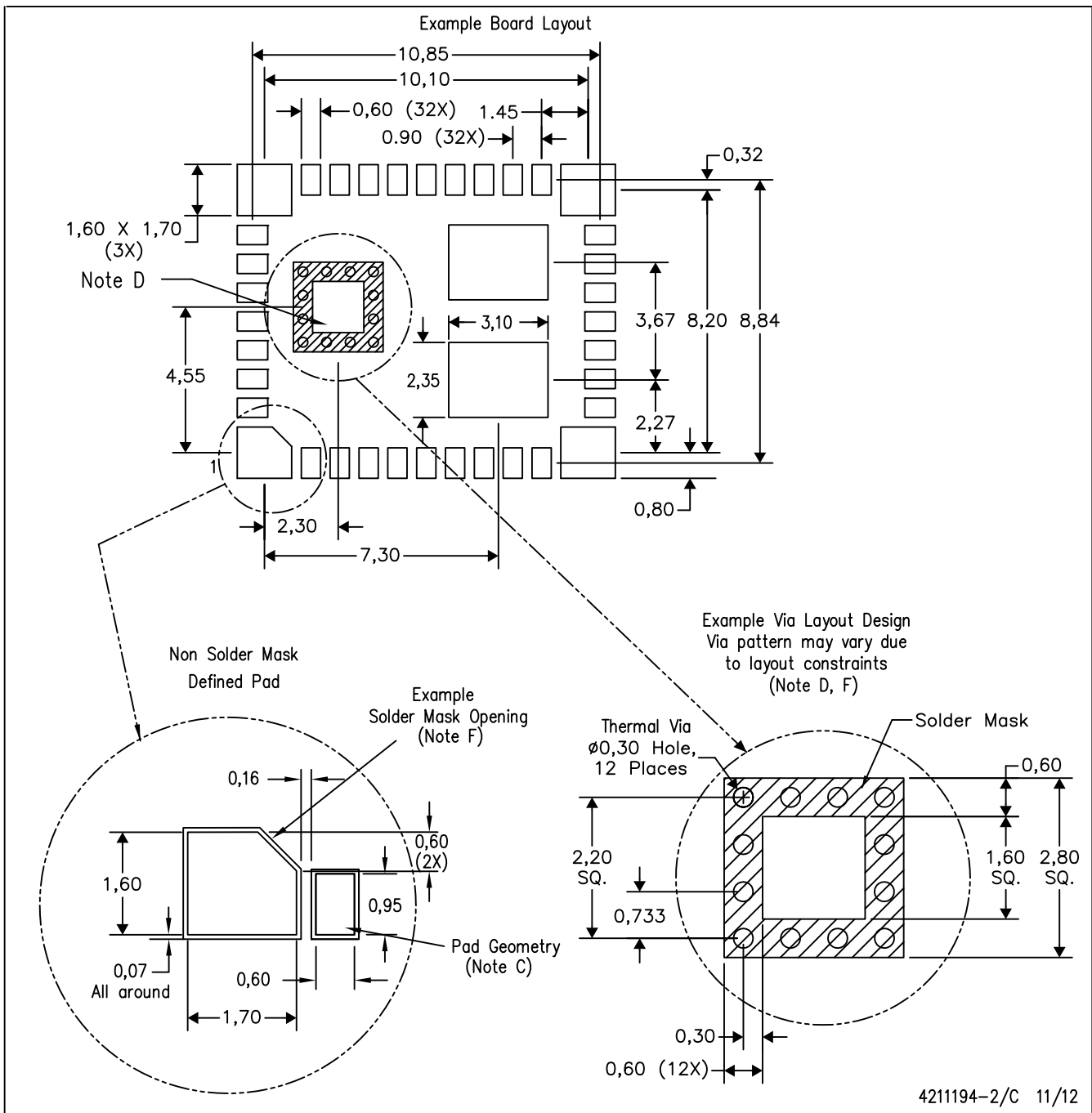

4211194-2/C 11/12

- NOTES:
- A. All linear dimensions are in millimeters.
  - B. This drawing is subject to change without notice.
  - C. Publication IPC-7351 is recommended for alternate designs.
  - D. This package is designed to be soldered to a thermal pad on the board. Refer to Application Note, Quad Flat-Pack Packages, Texas Instruments Literature No. SLUA271, and also the Product Data Sheets for specific thermal information, via requirements, and recommended board layout. These documents are available at [www.ti.com](http://www.ti.com) <<http://www.ti.com>>.
  - E. Laser cutting apertures with trapezoidal walls and also rounding corners will offer better paste release. Customers should contact their board assembly site for stencil design recommendations. Refer to IPC 7525 for stencil design considerations.
  - F. Customers should contact their board fabrication site for minimum solder mask web tolerances between signal pads.



## IMPORTANT NOTICE

Texas Instruments Incorporated and its subsidiaries (TI) reserve the right to make corrections, enhancements, improvements and other changes to its semiconductor products and services per JESD46, latest issue, and to discontinue any product or service per JESD48, latest issue. Buyers should obtain the latest relevant information before placing orders and should verify that such information is current and complete. All semiconductor products (also referred to herein as "components") are sold subject to TI's terms and conditions of sale supplied at the time of order acknowledgment.

TI warrants performance of its components to the specifications applicable at the time of sale, in accordance with the warranty in TI's terms and conditions of sale of semiconductor products. Testing and other quality control techniques are used to the extent TI deems necessary to support this warranty. Except where mandated by applicable law, testing of all parameters of each component is not necessarily performed.

TI assumes no liability for applications assistance or the design of Buyers' products. Buyers are responsible for their products and applications using TI components. To minimize the risks associated with Buyers' products and applications, Buyers should provide adequate design and operating safeguards.

TI does not warrant or represent that any license, either express or implied, is granted under any patent right, copyright, mask work right, or other intellectual property right relating to any combination, machine, or process in which TI components or services are used. Information published by TI regarding third-party products or services does not constitute a license to use such products or services or a warranty or endorsement thereof. Use of such information may require a license from a third party under the patents or other intellectual property of the third party, or a license from TI under the patents or other intellectual property of TI.

Reproduction of significant portions of TI information in TI data books or data sheets is permissible only if reproduction is without alteration and is accompanied by all associated warranties, conditions, limitations, and notices. TI is not responsible or liable for such altered documentation. Information of third parties may be subject to additional restrictions.

Resale of TI components or services with statements different from or beyond the parameters stated by TI for that component or service voids all express and any implied warranties for the associated TI component or service and is an unfair and deceptive business practice. TI is not responsible or liable for any such statements.

Buyer acknowledges and agrees that it is solely responsible for compliance with all legal, regulatory and safety-related requirements concerning its products, and any use of TI components in its applications, notwithstanding any applications-related information or support that may be provided by TI. Buyer represents and agrees that it has all the necessary expertise to create and implement safeguards which anticipate dangerous consequences of failures, monitor failures and their consequences, lessen the likelihood of failures that might cause harm and take appropriate remedial actions. Buyer will fully indemnify TI and its representatives against any damages arising out of the use of any TI components in safety-critical applications.

In some cases, TI components may be promoted specifically to facilitate safety-related applications. With such components, TI's goal is to help enable customers to design and create their own end-product solutions that meet applicable functional safety standards and requirements. Nonetheless, such components are subject to these terms.

No TI components are authorized for use in FDA Class III (or similar life-critical medical equipment) unless authorized officers of the parties have executed a special agreement specifically governing such use.

Only those TI components which TI has specifically designated as military grade or "enhanced plastic" are designed and intended for use in military/aerospace applications or environments. Buyer acknowledges and agrees that any military or aerospace use of TI components which have **not** been so designated is solely at the Buyer's risk, and that Buyer is solely responsible for compliance with all legal and regulatory requirements in connection with such use.

TI has specifically designated certain components as meeting ISO/TS16949 requirements, mainly for automotive use. In any case of use of non-designated products, TI will not be responsible for any failure to meet ISO/TS16949.

### Products

Audio	<a href="http://www.ti.com/audio">www.ti.com/audio</a>
Amplifiers	<a href="http://amplifier.ti.com">amplifier.ti.com</a>
Data Converters	<a href="http://dataconverter.ti.com">dataconverter.ti.com</a>
DLP® Products	<a href="http://www.dlp.com">www.dlp.com</a>
DSP	<a href="http://dsp.ti.com">dsp.ti.com</a>
Clocks and Timers	<a href="http://www.ti.com/clocks">www.ti.com/clocks</a>
Interface	<a href="http://interface.ti.com">interface.ti.com</a>
Logic	<a href="http://logic.ti.com">logic.ti.com</a>
Power Mgmt	<a href="http://power.ti.com">power.ti.com</a>
Microcontrollers	<a href="http://microcontroller.ti.com">microcontroller.ti.com</a>
RFID	<a href="http://www.ti-rfid.com">www.ti-rfid.com</a>
OMAP Applications Processors	<a href="http://www.ti.com/omap">www.ti.com/omap</a>
Wireless Connectivity	<a href="http://www.ti.com/wirelessconnectivity">www.ti.com/wirelessconnectivity</a>

### Applications

Automotive and Transportation	<a href="http://www.ti.com/automotive">www.ti.com/automotive</a>
Communications and Telecom	<a href="http://www.ti.com/communications">www.ti.com/communications</a>
Computers and Peripherals	<a href="http://www.ti.com/computers">www.ti.com/computers</a>
Consumer Electronics	<a href="http://www.ti.com/consumer-apps">www.ti.com/consumer-apps</a>
Energy and Lighting	<a href="http://www.ti.com/energy">www.ti.com/energy</a>
Industrial	<a href="http://www.ti.com/industrial">www.ti.com/industrial</a>
Medical	<a href="http://www.ti.com/medical">www.ti.com/medical</a>
Security	<a href="http://www.ti.com/security">www.ti.com/security</a>
Space, Avionics and Defense	<a href="http://www.ti.com/space-avionics-defense">www.ti.com/space-avionics-defense</a>
Video and Imaging	<a href="http://www.ti.com/video">www.ti.com/video</a>

### TI E2E Community

[e2e.ti.com](http://e2e.ti.com)

## Looking for pricing, stock, or lifecycle information?

Click below to explore more details on WIN SOURCE:

 [View TPS84410RKGR on WIN SOURCE](#)

 [Texas Instruments](#) Information

## Optimize Your Supply Chain with WIN SOURCE Solutions

-  Global Sourcing Solution
-  Obsolete Management
-  Cost Control Management
-  Shortage Management
-  Alternative Solution
-  Excess Inventory Management