



**THE DATASHEET OF  
TMS320C80GGP60**



# **TMS320C80**

## ***Digital Signal Processor***

# *Data Sheet*



*Data Sheet*

# **TMS320C80 DSP**

*1997*

- Single-Chip Parallel Multiple Instruction/Multiple Data (MIMD) DSP
- More Than Two Billion RISC-Equivalent Operations per Second
- Master Processor (MP)
  - 32-Bit Reduced Instruction Set Computing (RISC) Processor
  - IEEE-754 Floating-Point Capability
  - 4K-Byte Instruction Cache
  - 4K-Byte Data Cache
- Four Parallel Processors (PP)
  - 32-Bit Advanced DSPs
  - 64-Bit Opcode Provides Many Parallel Operations per Cycle
  - 2K-Byte Instruction Cache and 8K-Byte Data RAM per PP
- Transfer Controller (TC)
  - 64-Bit Data Transfers
  - Up to 480M-Byte/s Transfer Rate
  - 32-Bit Addressing
  - Direct DRAM/VRAM Interface With Dynamic Bus Sizing
  - Intelligent Queuing and Cycle Prioritization
- Video Controller (VC)
  - Provides Video Timing and VRAM Control
  - Dual-Frame Timers for Two Simultaneous Image-Capture and / or Display Systems
- Big- or Little-Endian Operation
- 50K-Byte On-Chip RAM
- 4G-Byte Address Space
- 16.6-ns Cycle Time
- 3.3-V Operation
- IEEE Standard 1149.1† Test Access Port (JTAG)

GF PACKAGE  
(BOTTOM VIEW)

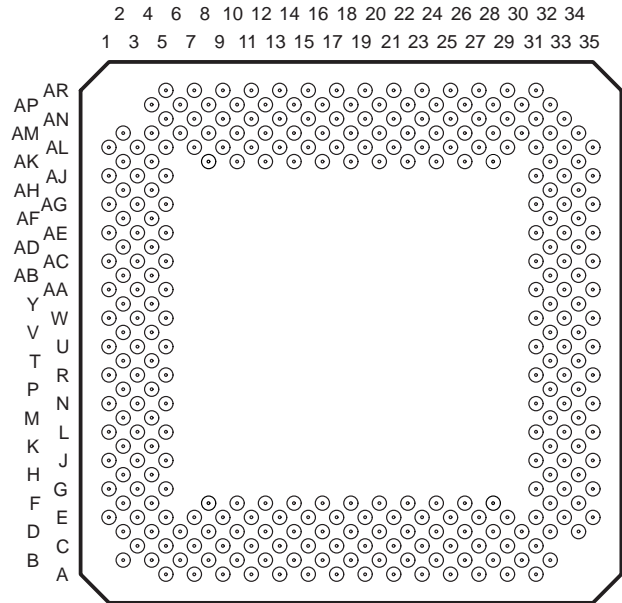

GGP PACKAGE  
(BOTTOM VIEW)

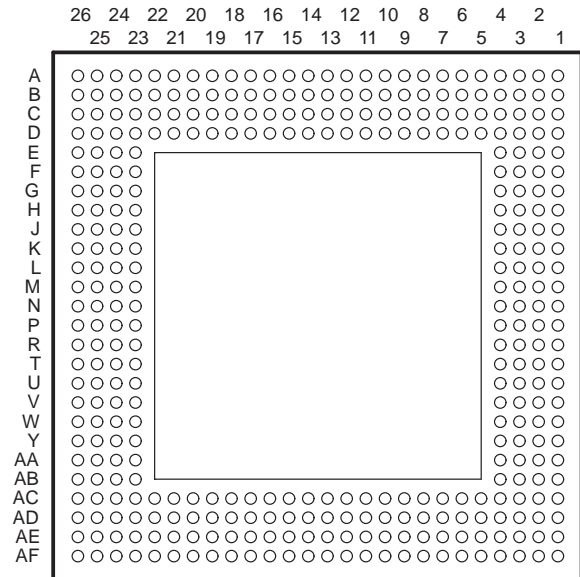

Please be aware that an important notice concerning availability, standard warranty, and use in critical applications of Texas Instruments semiconductor products and disclaimers thereto appears at the end of this data sheet.

† IEEE Standard 1149.1–1990, IEEE Standard Test Access Port and Boundary-Scan Architecture

# TMS320C80

## DIGITAL SIGNAL PROCESSOR

SPRS023B – JULY 1994 – REVISED OCTOBER 1997

---

### **description**

The TMS320C80 is a single chip, MIMD parallel processor capable of performing over two billion operations per second. It consists of a 32-bit RISC master processor with a 120-MFLOP IEEE floating-point unit, four 32-bit parallel processing digital signal processors (DSPs), a transfer controller with up to 480M-byte/s off-chip transfer rate, and a video controller. All the processors are coupled tightly through an on-chip crossbar that provides shared access to on-chip RAM. This performance and programmability make the 'C80 ideally suited for video, imaging, and high-speed telecommunications applications.



**GF Terminal Assignments – Numerical Listing**

| NO. | TERMINAL NAME                | NO. | TERMINAL NAME                           | NO. | TERMINAL NAME                | NO. | TERMINAL NAME   |
|-----|------------------------------|-----|---|-----|------------------------------|-----|-----------------|
| A5  | CT1                          | C21 | V <sub>DD</sub>                         | E33 | HSYNC <sub>0</sub>           | L5  | V <sub>SS</sub> |
| A7  | V <sub>DD</sub>              | C23 | $\overline{W}$                          | E35 | TCK                          | L31 | V <sub>SS</sub> |
| A9  | HACK                         | C25 | DBEN                                    | F2  | V <sub>DD</sub>              | L33 | TRST            |
| A11 | V <sub>SS</sub>              | C27 | V <sub>SS</sub>                         | F4  | V <sub>SS</sub>              | L35 | XPT1            |
| A13 | CAS/DQM7                     | C29 | CAREA0                                  | F8  | V <sub>DD</sub>              | M2  | V <sub>DD</sub> |
| A15 | CAS/DQM5                     | C31 | CBLNK <sub>0</sub> / VBLNK <sub>0</sub> | F10 | V <sub>SS</sub>              | M4  | V <sub>SS</sub> |
| A17 | V <sub>DD</sub>              | D2  | RETRY                                   | F12 | V <sub>DD</sub>              | M32 | V <sub>SS</sub> |
| A19 | V <sub>SS</sub>              | D4  | V <sub>DD</sub>                         | F14 | PS0                          | M34 | V <sub>DD</sub> |
| A21 | RAS                          | D6  | V <sub>SS</sub>                         | F16 | V <sub>SS</sub>              | N1  | V <sub>DD</sub> |
| A23 | DSF                          | D8  | AS0                                     | F18 | CT2                          | N3  | A8              |
| A25 | V <sub>SS</sub>              | D10 | UTIME                                   | F20 | V <sub>DD</sub>              | N5  | V <sub>SS</sub> |
| A27 | SCLK1                        | D12 | V <sub>SS</sub>                         | F22 | V <sub>SS</sub>              | N31 | V <sub>SS</sub> |
| A29 | V <sub>DD</sub>              | D14 | RESET                                   | F24 | V <sub>DD</sub>              | N33 | TMS             |
| A31 | EINT1                        | D16 | REQ0                                    | F26 | V <sub>SS</sub>              | N35 | V <sub>DD</sub> |
| B2  | No Connect                   | D18 | V <sub>SS</sub>                         | F28 | V <sub>DD</sub>              | P2  | A4              |
| B4  | BS1                          | D20 | CAS/DQM0                                | F32 | V <sub>SS</sub>              | P4  | A9              |
| B6  | V <sub>DD</sub>              | D22 | FCLK1                                   | F34 | V <sub>DD</sub>              | P32 | TDO             |
| B8  | PS1                          | D24 | V <sub>SS</sub>                         | G1  | V <sub>DD</sub>              | P34 | XPT0            |
| B10 | REQ1                         | D26 | CAREA1                                  | G3  | A2                           | R1  | V <sub>SS</sub> |
| B12 | V <sub>DD</sub>              | D28 | SCLK0                                   | G5  | A1                           | R3  | V <sub>DD</sub> |
| B14 | CAS/DQM6                     | D30 | V <sub>SS</sub>                         | G31 | EINT2                        | R5  | V <sub>DD</sub> |
| B16 | CAS/DQM3                     | D32 | V <sub>DD</sub>                         | G33 | CBLNK1 / VBLNK1              | R31 | V <sub>DD</sub> |
| B18 | V <sub>DD</sub>              | D34 | VS <sub>SYNC0</sub>                     | G35 | V <sub>DD</sub>              | R33 | V <sub>DD</sub> |
| B20 | CAS/DQM1                     | E1  | AS1                                     | H2  | STATUS0                      | R35 | V <sub>SS</sub> |
| B22 | TRG/CAS                      | E3  | FAULT                                   | H4  | A3                           | T2  | A5              |
| B24 | V <sub>DD</sub>              | E5  | V <sub>SS</sub>                         | H32 | CS <sub>SYNC1</sub> / HBLNK1 | T4  | A13             |
| B26 | DDIN                         | E7  | STATUS2                                 | H34 | TDI                          | T32 | D62             |
| B28 | FCLK0                        | E9  | READY                                   | J1  | STATUS1                      | T34 | EMU0            |
| B30 | V <sub>DD</sub>              | E11 | BS0                                     | J3  | V <sub>SS</sub>              | U1  | V <sub>DD</sub> |
| B32 | CS <sub>SYNC0</sub> / HBLNK0 | E13 | V <sub>SS</sub>                         | J5  | V <sub>DD</sub>              | U3  | A10             |
| C3  | V <sub>SS</sub>              | E15 | HREQ                                    | J31 | V <sub>DD</sub>              | U5  | PS3             |
| C5  | STATUS3                      | E17 | CAS/DQM4                                | J33 | V <sub>SS</sub>              | U31 | FF1             |
| C7  | AS2                          | E19 | RL                                      | J35 | EMU1                         | U33 | D61             |
| C9  | V <sub>SS</sub>              | E21 | STATUS5                                 | K2  | STATUS4                      | U35 | V <sub>DD</sub> |
| C11 | CT0                          | E23 | V <sub>SS</sub>                         | K4  | A6                           | V2  | V <sub>DD</sub> |
| C13 | PS2                          | E25 | CLKOUT                                  | K32 | VS <sub>SYNC1</sub>          | V4  | V <sub>SS</sub> |
| C15 | V <sub>DD</sub>              | E27 | LINT4                                   | K34 | HSYNC1                       | V32 | V <sub>SS</sub> |
| C17 | CLKIN                        | E29 | EINT3                                   | L1  | A0                           | V34 | V <sub>DD</sub> |
| C19 | CAS/DQM2                     | E31 | V <sub>SS</sub>                         | L3  | A7                           | W1  | A11             |

# TMS320C80 DIGITAL SIGNAL PROCESSOR

SPRS023B – JULY 1994 – REVISED OCTOBER 1997

## GF Terminal Assignments – Numerical Listing (Continued)

| TERMINAL |      | TERMINAL |      | TERMINAL |      | TERMINAL |      |
|----------|------|----------|------|----------|------|----------|------|
| NO.      | NAME | NO.      | NAME | NO.      | NAME | NO.      | NAME |
| W3       | A18  | AG1      | A16  | AL17     | D20  | AN29     | D35  |
| W5       | VSS  | AG3      | VSS  | AL19     | D21  | AN31     | D45  |
| W31      | VSS  | AG5      | VDD  | AL21     | D24  | AN33     | VDD  |
| W33      | D59  | AG31     | VDD  | AL23     | VSS  | AP4      | A27  |
| W35      | D63  | AG33     | VSS  | AL25     | D29  | AP6      | VDD  |
| Y2       | A12  | AG35     | D57  | AL27     | D32  | AP8      | D5   |
| Y4       | A19  | AH2      | A20  | AL29     | D38  | AP10     | D8   |
| Y32      | XPT2 | AH4      | A30  | AL31     | VSS  | AP12     | VDD  |
| Y34      | D56  | AH32     | D44  | AL33     | D48  | AP14     | D13  |
| AA1      | VSS  | AH34     | D54  | AL35     | D53  | AP16     | D17  |
| AA3      | VDD  | AJ1      | VDD  | AM2      | A24  | AP18     | VDD  |
| AA5      | VDD  | AJ3      | A31  | AM4      | VDD  | AP20     | D26  |
| AA31     | VDD  | AJ5      | VSS  | AM6      | VSS  | AP22     | D34  |
| AA33     | VDD  | AJ31     | VSS  | AM8      | D2   | AP24     | VDD  |
| AA35     | VSS  | AJ33     | D42  | AM10     | D6   | AP26     | D39  |
| AB2      | A14  | AJ35     | VDD  | AM12     | VSS  | AP28     | D41  |
| AB4      | A21  | AK2      | VDD  | AM14     | D14  | AP30     | VDD  |
| AB32     | D55  | AK4      | VSS  | AM16     | D19  | AP32     | D47  |
| AB34     | D60  | AK8      | VDD  | AM18     | VSS  | AR5      | D0   |
| AC1      | VDD  | AK10     | VSS  | AM20     | D23  | AR7      | VDD  |
| AC3      | A22  | AK12     | VDD  | AM22     | D25  | AR9      | D7   |
| AC5      | VSS  | AK14     | VSS  | AM24     | VSS  | AR11     | VSS  |
| AC31     | VSS  | AK16     | VDD  | AM26     | D31  | AR13     | D11  |
| AC33     | D52  | AK18     | FF2  | AM28     | D33  | AR15     | D15  |
| AC35     | VDD  | AK20     | VSS  | AM30     | VSS  | AR17     | VSS  |
| AD2      | VDD  | AK22     | D27  | AM32     | VDD  | AR19     | VDD  |
| AD4      | VSS  | AK24     | VDD  | AM34     | D50  | AR21     | D30  |
| AD32     | VSS  | AK26     | VSS  | AN5      | A29  | AR23     | D36  |
| AD34     | VDD  | AK28     | VDD  | AN7      | D1   | AR25     | VSS  |
| AE1      | A15  | AK32     | VSS  | AN9      | VSS  | AR27     | D40  |
| AE3      | A26  | AK34     | VDD  | AN11     | D9   | AR29     | VDD  |
| AE5      | VSS  | AL1      | A23  | AN13     | D12  | AR31     | D43  |
| AE31     | VSS  | AL3      | A25  | AN15     | VDD  |          |      |
| AE33     | D51  | AL5      | VSS  | AN17     | D18  |          |      |
| AE35     | D58  | AL7      | D3   | AN19     | D22  |          |      |
| AF2      | A17  | AL9      | D4   | AN21     | VDD  |          |      |
| AF4      | A28  | AL11     | D10  | AN23     | D28  |          |      |
| AF32     | D46  | AL13     | VSS  | AN25     | D37  |          |      |
| AF34     | D49  | AL15     | D16  | AN27     | VSS  |          |      |



**GF Terminal Assignments – Alphabetical Listing**

| TERMINAL |     | TERMINAL  |      | TERMINAL |      | TERMINAL                   |      |
|----------|-----|---|------|----------|------|----------------------------|------|
| NAME     | NO. | NAME  | NO.  | NAME     | NO.  | NAME                       | NO.  |
| A0       | L1  | $\overline{\text{CAS}}/\text{DQM0}$                 | D20  | D22      | AN19 | D61                        | U33  |
| A1       | G5  | $\overline{\text{CAS}}/\text{DQM1}$                 | B20  | D23      | AM20 | D62                        | T32  |
| A2       | G3  | $\overline{\text{CAS}}/\text{DQM2}$                 | C19  | D24      | AL21 | D63                        | W35  |
| A3       | H4  | $\overline{\text{CAS}}/\text{DQM3}$                 | B16  | D25      | AM22 | $\overline{\text{DBEN}}$   | C25  |
| A4       | P2  | $\overline{\text{CAS}}/\text{DQM4}$                 | E17  | D26      | AP20 | $\overline{\text{DDIN}}$   | B26  |
| A5       | T2  | $\overline{\text{CAS}}/\text{DQM5}$                 | A15  | D27      | AK22 | DSF                        | A23  |
| A6       | K4  | $\overline{\text{CAS}}/\text{DQM6}$                 | B14  | D28      | AN23 | $\overline{\text{EINT1}}$  | A31  |
| A7       | L3  | $\overline{\text{CAS}}/\text{DQM7}$                 | A13  | D29      | AL25 | $\overline{\text{EINT2}}$  | G31  |
| A8       | N3  | $\overline{\text{CBLNK0}}/\overline{\text{VBLNK0}}$ | C31  | D30      | AR21 | $\overline{\text{EINT3}}$  | E29  |
| A9       | P4  | $\overline{\text{CBLNK1}}/\overline{\text{VBLNK1}}$ | G33  | D31      | AM26 | EMU0                       | T34  |
| A10      | U3  | CLKIN   | C17  | D32      | AL27 | EMU1                       | J35  |
| A11      | W1  | CLKOUT  | E25  | D33      | AM28 | $\overline{\text{FAULT}}$  | E3   |
| A12      | Y2  | $\overline{\text{CSYNC0}}/\overline{\text{HBLNK0}}$ | B32  | D34      | AP22 | FCLK0                      | B28  |
| A13      | T4  | $\overline{\text{CSYNC1}}/\overline{\text{HBLNK1}}$ | H32  | D35      | AN29 | FCLK1                      | D22  |
| A14      | AB2 | CT0   | C11  | D36      | AR23 | FF1                        | U31  |
| A15      | AE1 | CT1   | A5   | D37      | AN25 | FF2                        | AK18 |
| A16      | AG1 | CT2   | F18  | D38      | AL29 | $\overline{\text{HACK}}$   | A9   |
| A17      | AF2 | D0  | AR5  | D39      | AP26 | $\overline{\text{HREQ}}$   | E15  |
| A18      | W3  | D1  | AN7  | D40      | AR27 | $\overline{\text{HSYNC0}}$ | E33  |
| A19      | Y4  | D2  | AM8  | D41      | AP28 | $\overline{\text{HSYNC1}}$ | K34  |
| A20      | AH2 | D3  | AL7  | D42      | AJ33 | $\overline{\text{LINT4}}$  | E27  |
| A21      | AB4 | D4  | AL9  | D43      | AR31 | PS0                        | F14  |
| A22      | AC3 | D5  | AP8  | D44      | AH32 | PS1                        | B8   |
| A23      | AL1 | D6  | AM10 | D45      | AN31 | PS2                        | C13  |
| A24      | AM2 | D7  | AR9  | D46      | AF32 | PS3                        | U5   |
| A25      | AL3 | D8  | AP10 | D47      | AP32 | $\overline{\text{RAS}}$    | A21  |
| A26      | AE3 | D9  | AN11 | D48      | AL33 | READY                      | E9   |
| A27      | AP4 | D10   | AL11 | D49      | AF34 | REQ0                       | D16  |
| A28      | AF4 | D11   | AR13 | D50      | AM34 | REQ1                       | B10  |
| A29      | AN5 | D12   | AN13 | D51      | AE33 | $\overline{\text{RESET}}$  | D14  |
| A30      | AH4 | D13   | AP14 | D52      | AC33 | $\overline{\text{RETRY}}$  | D2   |
| A31      | AJ3 | D14   | AM14 | D53      | AL35 | $\overline{\text{RL}}$     | E19  |
| AS0      | D8  | D15   | AR15 | D54      | AH34 | SCLK0                      | D28  |
| AS1      | E1  | D16   | AL15 | D55      | AB32 | SCLK1                      | A27  |
| AS2      | C7  | D17   | AP16 | D56      | Y34  | STATUS0                    | H2   |
| BS0      | E11 | D18   | AN17 | D57      | AG35 | STATUS1                    | J1   |
| BS1      | B4  | D19   | AM16 | D58      | AE35 | STATUS2                    | E7   |
| CAREA0   | C29 | D20   | AL17 | D59      | W33  | STATUS3                    | C5   |
| CAREA1   | D26 | D21   | AL19 | D60      | AB34 | STATUS4                    | K2   |

# TMS320C80 DIGITAL SIGNAL PROCESSOR

SPRS023B – JULY 1994 – REVISED OCTOBER 1997

## GF Terminal Assignments – Alphabetical Listing (Continued)

| TERMINAL<br>NAME            | TERMINAL<br>NO. | TERMINAL<br>NAME | TERMINAL<br>NO. | TERMINAL<br>NAME | TERMINAL<br>NO. | TERMINAL<br>NAME           | TERMINAL<br>NO. |
|-----------------------------|-----------------|------------------|-----------------|------------------|-----------------|----------------------------|-----------------|
| STATUS5                     | E21             | V <sub>DD</sub>  | R31             | V <sub>DD</sub>  | AR29            | V <sub>SS</sub>            | AA35            |
| TCK                         | E35             | V <sub>DD</sub>  | R33             | V <sub>SS</sub>  | A11             | V <sub>SS</sub>            | AC5             |
| TDI                         | H34             | V <sub>DD</sub>  | U1              | V <sub>SS</sub>  | A19             | V <sub>SS</sub>            | AC31            |
| TDO                         | P32             | V <sub>DD</sub>  | U35             | V <sub>SS</sub>  | A25             | V <sub>SS</sub>            | AD4             |
| TMS                         | N33             | V <sub>DD</sub>  | V2              | V <sub>SS</sub>  | C3              | V <sub>SS</sub>            | AD32            |
| $\overline{\text{TRG/CAS}}$ | B22             | V <sub>DD</sub>  | V34             | V <sub>SS</sub>  | C9              | V <sub>SS</sub>            | AE5             |
| TRST                        | L33             | V <sub>DD</sub>  | AA3             | V <sub>SS</sub>  | C27             | V <sub>SS</sub>            | AE31            |
| UTIME                       | D10             | V <sub>DD</sub>  | AA5             | V <sub>SS</sub>  | D6              | V <sub>SS</sub>            | AG3             |
| V <sub>DD</sub>             | A7              | V <sub>DD</sub>  | AA31            | V <sub>SS</sub>  | D12             | V <sub>SS</sub>            | AG33            |
| V <sub>DD</sub>             | A17             | V <sub>DD</sub>  | AA33            | V <sub>SS</sub>  | D18             | V <sub>SS</sub>            | AJ5             |
| V <sub>DD</sub>             | A29             | V <sub>DD</sub>  | AC1             | V <sub>SS</sub>  | D24             | V <sub>SS</sub>            | AJ31            |
| V <sub>DD</sub>             | B6              | V <sub>DD</sub>  | AC35            | V <sub>SS</sub>  | D30             | V <sub>SS</sub>            | AK4             |
| V <sub>DD</sub>             | B12             | V <sub>DD</sub>  | AD2             | V <sub>SS</sub>  | E5              | V <sub>SS</sub>            | AK10            |
| V <sub>DD</sub>             | B18             | V <sub>DD</sub>  | AD34            | V <sub>SS</sub>  | E13             | V <sub>SS</sub>            | AK14            |
| V <sub>DD</sub>             | B24             | V <sub>DD</sub>  | AG5             | V <sub>SS</sub>  | E23             | V <sub>SS</sub>            | AK20            |
| V <sub>DD</sub>             | B30             | V <sub>DD</sub>  | AG31            | V <sub>SS</sub>  | E31             | V <sub>SS</sub>            | AK26            |
| V <sub>DD</sub>             | C15             | V <sub>DD</sub>  | AJ1             | V <sub>SS</sub>  | F4              | V <sub>SS</sub>            | AK32            |
| V <sub>DD</sub>             | C21             | V <sub>DD</sub>  | AJ35            | V <sub>SS</sub>  | F10             | V <sub>SS</sub>            | AL5             |
| V <sub>DD</sub>             | D4              | V <sub>DD</sub>  | AK2             | V <sub>SS</sub>  | F16             | V <sub>SS</sub>            | AL13            |
| V <sub>DD</sub>             | D32             | V <sub>DD</sub>  | AK8             | V <sub>SS</sub>  | F22             | V <sub>SS</sub>            | AL23            |
| V <sub>DD</sub>             | F2              | V <sub>DD</sub>  | AK12            | V <sub>SS</sub>  | F26             | V <sub>SS</sub>            | AL31            |
| V <sub>DD</sub>             | F8              | V <sub>DD</sub>  | AK16            | V <sub>SS</sub>  | F32             | V <sub>SS</sub>            | AM6             |
| V <sub>DD</sub>             | F12             | V <sub>DD</sub>  | AK24            | V <sub>SS</sub>  | J3              | V <sub>SS</sub>            | AM12            |
| V <sub>DD</sub>             | F20             | V <sub>DD</sub>  | AK28            | V <sub>SS</sub>  | J33             | V <sub>SS</sub>            | AM18            |
| V <sub>DD</sub>             | F24             | V <sub>DD</sub>  | AK34            | V <sub>SS</sub>  | L5              | V <sub>SS</sub>            | AM24            |
| V <sub>DD</sub>             | F28             | V <sub>DD</sub>  | AM4             | V <sub>SS</sub>  | L31             | V <sub>SS</sub>            | AM30            |
| V <sub>DD</sub>             | F34             | V <sub>DD</sub>  | AM32            | V <sub>SS</sub>  | M4              | V <sub>SS</sub>            | AN9             |
| V <sub>DD</sub>             | G1              | V <sub>DD</sub>  | AN15            | V <sub>SS</sub>  | M32             | V <sub>SS</sub>            | AN27            |
| V <sub>DD</sub>             | G35             | V <sub>DD</sub>  | AN21            | V <sub>SS</sub>  | N5              | V <sub>SS</sub>            | AR11            |
| V <sub>DD</sub>             | J5              | V <sub>DD</sub>  | AN33            | V <sub>SS</sub>  | N31             | V <sub>SS</sub>            | AR17            |
| V <sub>DD</sub>             | J31             | V <sub>DD</sub>  | AP6             | V <sub>SS</sub>  | R1              | V <sub>SS</sub>            | AR25            |
| V <sub>DD</sub>             | M2              | V <sub>DD</sub>  | AP12            | V <sub>SS</sub>  | R35             | $\overline{\text{VSYNC0}}$ | D34             |
| V <sub>DD</sub>             | M34             | V <sub>DD</sub>  | AP18            | V <sub>SS</sub>  | V4              | $\overline{\text{VSYNC1}}$ | K32             |
| V <sub>DD</sub>             | N1              | V <sub>DD</sub>  | AP24            | V <sub>SS</sub>  | V32             | $\overline{\text{W}}$      | C23             |
| V <sub>DD</sub>             | N35             | V <sub>DD</sub>  | AP30            | V <sub>SS</sub>  | W5              | $\overline{\text{XPT0}}$   | P34             |
| V <sub>DD</sub>             | R3              | V <sub>DD</sub>  | AR7             | V <sub>SS</sub>  | W31             | $\overline{\text{XPT1}}$   | L35             |
| V <sub>DD</sub>             | R5              | V <sub>DD</sub>  | AR19            | V <sub>SS</sub>  | AA1             | $\overline{\text{XPT2}}$   | Y32             |



**GGP Terminal Assignments – Numerical Listing**

| TERMINAL |                 | TERMINAL |                 | TERMINAL |                 | TERMINAL |                 |
|----------|-----------------|----------|-----------------|----------|-----------------|----------|-----------------|
| NO.      | NAME            | NO.      | NAME            | NO.      | NAME            | NO.      | NAME            |
| A1       | No Connect      | B1       | No Connect      | C1       | No Connect      | D1       | A0              |
| A2       | No Connect      | B2       | No Connect      | C2       | No Connect      | D2       | V <sub>DD</sub> |
| A3       | No Connect      | B3       | No Connect      | C3       | No Connect      | D3       | STATUS4         |
| A4       | STATUS1         | B4       | STATUS2         | C4       | V <sub>SS</sub> | D4       | STATUS3         |
| A5       | AS1             | B5       | AS2             | C5       | STATUS0         | D5       | V <sub>DD</sub> |
| A6       | <u>RETRY</u>    | B6       | READY           | C6       | <u>FAULT</u>    | D6       | AS0             |
| A7       | CT1             | B7       | BS0             | C7       | BS1             | D7       | <u>UTIME</u>    |
| A8       | PS0             | B8       | PS1             | C8       | PS2             | D8       | CT0             |
| A9       | V <sub>DD</sub> | B9       | <u>HACK</u>     | C9       | <u>HREQ</u>     | D9       | <u>RESET</u>    |
| A10      | V <sub>SS</sub> | B10      | V <sub>SS</sub> | C10      | V <sub>SS</sub> | D10      | REQ1            |
| A11      | V <sub>SS</sub> | B11      | V <sub>DD</sub> | C11      | V <sub>DD</sub> | D11      | REQ0            |
| A12      | V <sub>DD</sub> | B12      | <u>CAS/DQM7</u> | C12      | CLKIN           | D12      | V <sub>DD</sub> |
| A13      | No Connect      | B13      | No Connect      | C13      | V <sub>SS</sub> | D13      | <u>CAS/DQM6</u> |
| A14      | No Connect      | B14      | V <sub>SS</sub> | C14      | <u>CAS/DQM5</u> | D14      | V <sub>DD</sub> |
| A15      | V <sub>DD</sub> | B15      | <u>CAS/DQM4</u> | C15      | <u>CAS/DQM3</u> | D15      | CT2             |
| A16      | <u>CAS/DQM2</u> | B16      | V <sub>SS</sub> | C16      | <u>CAS/DQM1</u> | D16      | V <sub>DD</sub> |
| A17      | <u>CAS/DQM0</u> | B17      | <u>RL</u>       | C17      | V <sub>SS</sub> | D17      | V <sub>SS</sub> |
| A18      | V <sub>SS</sub> | B18      | <u>RAS</u>      | C18      | V <sub>DD</sub> | D18      | <u>TRG/CAS</u>  |
| A19      | FCLK1           | B19      | V <sub>DD</sub> | C19      | <u>W</u>        | D19      | STATUS5         |
| A20      | V <sub>DD</sub> | B20      | DSF             | C20      | V <sub>SS</sub> | D20      | <u>DBEN</u>     |
| A21      | V <sub>DD</sub> | B21      | <u>DDIN</u>     | C21      | CLKOUT          | D21      | CAREA1          |
| A22      | V <sub>SS</sub> | B22      | SCLK1           | C22      | V <sub>DD</sub> | D22      | FCLK0           |
| A23      | V <sub>SS</sub> | B23      | SCLK0           | C23      | V <sub>DD</sub> | D23      | CAREA0          |
| A24      | No Connect      | B24      | No Connect      | C24      | No Connect      | D24      | <u>LINT4</u>    |
| A25      | No Connect      | B25      | No Connect      | C25      | No Connect      | D25      | <u>EINT3</u>    |
| A26      | No Connect      | B26      | No Connect      | C26      | No Connect      | D26      | <u>EINT2</u>    |

# TMS320C80 DIGITAL SIGNAL PROCESSOR

SPRS023B – JULY 1994 – REVISED OCTOBER 1997

## GGP Terminal Assignments – Numerical Listing (Continued)

| TERMINAL |                                   | TERMINAL |                            | TERMINAL |                          | TERMINAL |                 |
|----------|-----------------------------------|----------|----------------------------|----------|--------------------------|----------|-----------------|
| NO.      | NAME                              | NO.      | NAME                       | NO.      | NAME                     | NO.      | NAME            |
| E1       | A3                                | J23      | $\overline{\text{HSYNC0}}$ | P1       | No Connect               | V23      | D52             |
| E2       | A2                                | J24      | $\overline{\text{TRST}}$   | P2       | No Connect               | V24      | V <sub>SS</sub> |
| E3       | V <sub>SS</sub>                   | J25      | TCK                        | P3       | V <sub>SS</sub>          | V25      | V <sub>SS</sub> |
| E4       | A1                                | J26      | TMS                        | P4       | V <sub>SS</sub>          | V26      | D53             |
| E23      | $\overline{\text{EINT1}}$         | K1       | A12                        | P23      | V <sub>SS</sub>          | W1       | A24             |
| E24      | $\overline{\text{CBLNK1/VBLNK1}}$ | K2       | V <sub>DD</sub>            | P24      | D59                      | W2       | V <sub>SS</sub> |
| E25      | $\overline{\text{CBLNK0/VBLNK0}}$ | K3       | A11                        | P25      | V <sub>DD</sub>          | W3       | V <sub>SS</sub> |
| E26      | V <sub>SS</sub>                   | K4       | V <sub>SS</sub>            | P26      | No Connect               | W4       | V <sub>SS</sub> |
| F1       | A4                                | K23      | TDI                        | R1       | V <sub>SS</sub>          | W23      | D49             |
| F2       | V <sub>DD</sub>                   | K24      | TDO                        | R2       | A17                      | W24      | D50             |
| F3       | V <sub>DD</sub>                   | K25      | EMU1                       | R3       | A18                      | W25      | D51             |
| F4       | V <sub>DD</sub>                   | K26      | $\overline{\text{XPT0}}$   | R4       | V <sub>SS</sub>          | W26      | V <sub>DD</sub> |
| F23      | V <sub>SS</sub>                   | L1       | V <sub>DD</sub>            | R23      | $\overline{\text{XPT2}}$ | Y1       | A25             |
| F24      | $\overline{\text{CSYNC1/HBLNK1}}$ | L2       | A13                        | R24      | D57                      | Y2       | A26             |
| F25      | V <sub>DD</sub>                   | L3       | V <sub>SS</sub>            | R25      | V <sub>DD</sub>          | Y3       | A27             |
| F26      | $\overline{\text{CSYNC0/HBLNK0}}$ | L4       | V <sub>SS</sub>            | R26      | D58                      | Y4       | V <sub>DD</sub> |
| G1       | V <sub>SS</sub>                   | L23      | $\overline{\text{XPT1}}$   | T1       | A19                      | Y23      | V <sub>DD</sub> |
| G2       | V <sub>SS</sub>                   | L24      | V <sub>SS</sub>            | T2       | V <sub>DD</sub>          | Y24      | D48             |
| G3       | A5                                | L25      | V <sub>SS</sub>            | T3       | V <sub>DD</sub>          | Y25      | V <sub>SS</sub> |
| G4       | V <sub>SS</sub>                   | L26      | EMU0                       | T4       | A20                      | Y26      | V <sub>SS</sub> |
| G23      | $\overline{\text{VSYNC1}}$        | M1       | V <sub>DD</sub>            | T23      | V <sub>DD</sub>          | AA1      | V <sub>DD</sub> |
| G24      | $\overline{\text{VSYNC0}}$        | M2       | A15                        | T24      | V <sub>DD</sub>          | AA2      | V <sub>DD</sub> |
| G25      | V <sub>SS</sub>                   | M3       | PS3                        | T25      | D56                      | AA3      | A28             |
| G26      | V <sub>SS</sub>                   | M4       | A14                        | T26      | V <sub>SS</sub>          | AA4      | V <sub>SS</sub> |
| H1       | A8                                | M23      | V <sub>DD</sub>            | U1       | V <sub>SS</sub>          | AA23     | D45             |
| H2       | V <sub>DD</sub>                   | M24      | D63                        | U2       | V <sub>SS</sub>          | AA24     | D46             |
| H3       | A7                                | M25      | D62                        | U3       | A21                      | AA25     | D47             |
| H4       | A6                                | M26      | D61                        | U4       | V <sub>DD</sub>          | AA26     | V <sub>DD</sub> |
| H23      | $\overline{\text{HSYNC1}}$        | N1       | No Connect                 | U23      | V <sub>DD</sub>          | AB1      | V <sub>SS</sub> |
| H24      | V <sub>DD</sub>                   | N2       | A16                        | U24      | D54                      | AB2      | A29             |
| H25      | V <sub>DD</sub>                   | N3       | V <sub>DD</sub>            | U25      | V <sub>SS</sub>          | AB3      | A30             |
| H26      | V <sub>DD</sub>                   | N4       | V <sub>DD</sub>            | U26      | D55                      | AB4      | V <sub>SS</sub> |
| J1       | A10                               | N23      | V <sub>SS</sub>            | V1       | A22                      | AB23     | V <sub>DD</sub> |
| J2       | V <sub>DD</sub>                   | N24      | D60                        | V2       | A23                      | AB24     | D44             |
| J3       | A9                                | N25      | No Connect                 | V3       | V <sub>DD</sub>          | AB25     | V <sub>SS</sub> |
| J4       | V <sub>SS</sub>                   | N26      | No Connect                 | V4       | V <sub>DD</sub>          | AB26     | V <sub>SS</sub> |



**GGP Terminal Assignments – Numerical Listing (Continued)**

| TERMINAL |                 | TERMINAL |                 | TERMINAL |                 | TERMINAL |                 |
|----------|-----------------|----------|-----------------|----------|-----------------|----------|-----------------|
| NO.      | NAME            | NO.      | NAME            | NO.      | NAME            | NO.      | NAME            |
| AC1      | A31             | AD1      | No Connect      | AE1      | No Connect      | AF1      | No Connect      |
| AC2      | V <sub>DD</sub> | AD2      | No Connect      | AE2      | No Connect      | AF2      | No Connect      |
| AC3      | V <sub>DD</sub> | AD3      | No Connect      | AE3      | No Connect      | AF3      | No Connect      |
| AC4      | D0              | AD4      | V <sub>SS</sub> | AE4      | D1              | AF4      | D2              |
| AC5      | D3              | AD5      | V <sub>DD</sub> | AE5      | D4              | AF5      | V <sub>SS</sub> |
| AC6      | V <sub>SS</sub> | AD6      | D5              | AE6      | D6              | AF6      | D7              |
| AC7      | V <sub>DD</sub> | AD7      | V <sub>DD</sub> | AE7      | D8              | AF7      | V <sub>SS</sub> |
| AC8      | D9              | AD8      | D10             | AE8      | D11             | AF8      | V <sub>DD</sub> |
| AC9      | D12             | AD9      | V <sub>SS</sub> | AE9      | D13             | AF9      | D14             |
| AC10     | V <sub>DD</sub> | AD10     | V <sub>DD</sub> | AE10     | D15             | AF10     | V <sub>SS</sub> |
| AC11     | D16             | AD11     | V <sub>SS</sub> | AE11     | V <sub>SS</sub> | AF11     | D17             |
| AC12     | D18             | AD12     | D19             | AE12     | V <sub>DD</sub> | AF12     | V <sub>DD</sub> |
| AC13     | D20             | AD13     | V <sub>SS</sub> | AE13     | V <sub>SS</sub> | AF13     | No Connect      |
| AC14     | V <sub>DD</sub> | AD14     | D21             | AE14     | No Connect      | AF14     | No Connect      |
| AC15     | D24             | AD15     | V <sub>DD</sub> | AE15     | D23             | AF15     | D22             |
| AC16     | D27             | AD16     | D26             | AE16     | D25             | AF16     | V <sub>SS</sub> |
| AC17     | V <sub>SS</sub> | AD17     | V <sub>SS</sub> | AE17     | D28             | AF17     | V <sub>DD</sub> |
| AC18     | D31             | AD18     | D30             | AE18     | V <sub>DD</sub> | AF18     | D29             |
| AC19     | V <sub>DD</sub> | AD19     | V <sub>DD</sub> | AE19     | D32             | AF19     | V <sub>SS</sub> |
| AC20     | D35             | AD20     | D34             | AE20     | D33             | AF20     | V <sub>SS</sub> |
| AC21     | D37             | AD21     | V <sub>SS</sub> | AE21     | D36             | AF21     | V <sub>DD</sub> |
| AC22     | D40             | AD22     | V <sub>DD</sub> | AE22     | D39             | AF22     | D38             |
| AC23     | D42             | AD23     | D41             | AE23     | V <sub>SS</sub> | AF23     | V <sub>SS</sub> |
| AC24     | D43             | AD24     | No Connect      | AE24     | No Connect      | AF24     | No Connect      |
| AC25     | V <sub>DD</sub> | AD25     | No Connect      | AE25     | No Connect      | AF25     | No Connect      |
| AC26     | V <sub>DD</sub> | AD26     | No Connect      | AE26     | No Connect      | AF26     | No Connect      |

# TMS320C80 DIGITAL SIGNAL PROCESSOR

SPRS023B – JULY 1994 – REVISED OCTOBER 1997

## GGP Terminal Assignments – Alphabetical Listing

| TERMINAL<br>NAME | NO. | TERMINAL<br>NAME                                    | NO.  | TERMINAL<br>NAME | NO.  | TERMINAL<br>NAME           | NO. |
|------------------|-----|---|------|------------------|------|----------------------------|-----|
| A0               | D1  | $\overline{\text{CAS}}/\text{DQM0}$                 | A17  | D22              | AF15 | D61                        | M26 |
| A1               | E4  | $\overline{\text{CAS}}/\text{DQM1}$                 | C16  | D23              | AE15 | D62                        | M25 |
| A2               | E2  | $\overline{\text{CAS}}/\text{DQM2}$                 | A16  | D24              | AC15 | D63                        | M24 |
| A3               | E1  | $\overline{\text{CAS}}/\text{DQM3}$                 | C15  | D25              | AE16 | $\overline{\text{DBEN}}$   | D20 |
| A4               | F1  | $\overline{\text{CAS}}/\text{DQM4}$                 | B15  | D26              | AD16 | $\overline{\text{DDIN}}$   | B21 |
| A5               | G3  | $\overline{\text{CAS}}/\text{DQM5}$                 | C14  | D27              | AC16 | $\overline{\text{DSF}}$    | B20 |
| A6               | H4  | $\overline{\text{CAS}}/\text{DQM6}$                 | D13  | D28              | AE17 | $\overline{\text{EINT1}}$  | E23 |
| A7               | H3  | $\overline{\text{CAS}}/\text{DQM7}$                 | B12  | D29              | AF18 | $\overline{\text{EINT2}}$  | D26 |
| A8               | H1  | $\overline{\text{CBLNK0}}/\overline{\text{VBLNK0}}$ | E25  | D30              | AD18 | $\overline{\text{EINT3}}$  | D25 |
| A9               | J3  | $\overline{\text{CBLNK1}}/\overline{\text{VBLNK1}}$ | E24  | D31              | AC18 | EMU0                       | L26 |
| A10              | J1  | CLKIN   | C12  | D32              | AE19 | EMU1                       | K25 |
| A11              | K3  | CLKOUT  | C21  | D33              | AE20 | $\overline{\text{FAULT}}$  | C6  |
| A12              | K1  | $\overline{\text{CSYNC0}}/\overline{\text{HBLNK0}}$ | F26  | D34              | AD20 | FCLK0                      | D22 |
| A13              | L2  | $\overline{\text{CSYNC1}}/\overline{\text{HBLNK1}}$ | F24  | D35              | AC20 | FCLK1                      | A19 |
| A14              | M4  | CT0   | D8   | D36              | AE21 | $\overline{\text{HACK}}$   | B9  |
| A15              | M2  | CT1   | A7   | D37              | AC21 | $\overline{\text{HREQ}}$   | C9  |
| A16              | N2  | CT2   | D15  | D38              | AF22 | $\overline{\text{HSYNC0}}$ | J23 |
| A17              | R2  | D0  | AC4  | D39              | AE22 | $\overline{\text{HSYNC1}}$ | H23 |
| A18              | R3  | D1  | AE4  | D40              | AC22 | $\overline{\text{LINT4}}$  | D24 |
| A19              | T1  | D2  | AF4  | D41              | AD23 | PS0                        | A8  |
| A20              | T4  | D3  | AC5  | D42              | AC23 | PS1                        | B8  |
| A21              | U3  | D4  | AE5  | D43              | AC24 | PS2                        | C8  |
| A22              | V1  | D5  | AD6  | D44              | AB24 | PS3                        | M3  |
| A23              | V2  | D6  | AE6  | D45              | AA23 | RAS                        | B18 |
| A24              | W1  | D7  | AF6  | D46              | AA24 | READY                      | B6  |
| A25              | Y1  | D8  | AE7  | D47              | AA25 | REQ0                       | D11 |
| A26              | Y2  | D9  | AC8  | D48              | Y24  | REQ1                       | D10 |
| A27              | Y3  | D10   | AD8  | D49              | W23  | $\overline{\text{RESET}}$  | D9  |
| A28              | AA3 | D11   | AE8  | D50              | W24  | $\overline{\text{RETRY}}$  | A6  |
| A29              | AB2 | D12   | AC9  | D51              | W25  | $\overline{\text{RL}}$     | B17 |
| A30              | AB3 | D13   | AE9  | D52              | V23  | SCLK0                      | B23 |
| A31              | AC1 | D14   | AF9  | D53              | V26  | SCLK1                      | B22 |
| AS0              | D6  | D15   | AE10 | D54              | U24  | STATUS0                    | C5  |
| AS1              | A5  | D16   | AC11 | D55              | U26  | STATUS1                    | A4  |
| AS2              | B5  | D17   | AF11 | D56              | T25  | STATUS2                    | B4  |
| BS0              | B7  | D18   | AC12 | D57              | R24  | STATUS3                    | D4  |
| BS1              | C7  | D19   | AD12 | D58              | R26  | STATUS4                    | D3  |
| CAREA0           | D23 | D20   | AC13 | D59              | P24  | STATUS5                    | D19 |
| CAREA1           | D21 | D21   | AD14 | D60              | N24  |                            |     |



**GGP Terminal Assignments – Alphabetical Listing (Continued)**

| TERMINAL                    |     | TERMINAL        |      | TERMINAL        |     | TERMINAL                   |      |
|-----------------------------|-----|-----------------|------|-----------------|-----|----------------------------|------|
| NAME                        | NO. | NAME            | NO.  | NAME            | NO. | NAME                       | NO.  |
| TCK                         | J25 | V <sub>DD</sub> | P25  | V <sub>SS</sub> | A10 | V <sub>SS</sub>            | U25  |
| TDI                         | K23 | V <sub>DD</sub> | R25  | V <sub>SS</sub> | A11 | V <sub>SS</sub>            | V24  |
| TDO                         | K24 | V <sub>DD</sub> | T2   | V <sub>SS</sub> | A18 | V <sub>SS</sub>            | V25  |
| TMS                         | J26 | V <sub>DD</sub> | T3   | V <sub>SS</sub> | A22 | V <sub>SS</sub>            | W2   |
| $\overline{\text{TRG/CAS}}$ | D18 | V <sub>DD</sub> | T23  | V <sub>SS</sub> | A23 | V <sub>SS</sub>            | W3   |
| $\overline{\text{TRST}}$    | J24 | V <sub>DD</sub> | T24  | V <sub>SS</sub> | B10 | V <sub>SS</sub>            | W4   |
| $\overline{\text{UTIME}}$   | D7  | V <sub>DD</sub> | U4   | V <sub>SS</sub> | B14 | V <sub>SS</sub>            | Y25  |
| V <sub>DD</sub>             | A9  | V <sub>DD</sub> | U23  | V <sub>SS</sub> | B16 | V <sub>SS</sub>            | Y26  |
| V <sub>DD</sub>             | A12 | V <sub>DD</sub> | V3   | V <sub>SS</sub> | C4  | V <sub>SS</sub>            | AA4  |
| V <sub>DD</sub>             | A15 | V <sub>DD</sub> | V4   | V <sub>SS</sub> | C10 | V <sub>SS</sub>            | AB1  |
| V <sub>DD</sub>             | A20 | V <sub>DD</sub> | W26  | V <sub>SS</sub> | C13 | V <sub>SS</sub>            | AB4  |
| V <sub>DD</sub>             | A21 | V <sub>DD</sub> | Y4   | V <sub>SS</sub> | C17 | V <sub>SS</sub>            | AB25 |
| V <sub>DD</sub>             | B11 | V <sub>DD</sub> | Y23  | V <sub>SS</sub> | C20 | V <sub>SS</sub>            | AB26 |
| V <sub>DD</sub>             | B19 | V <sub>DD</sub> | AA1  | V <sub>SS</sub> | D17 | V <sub>SS</sub>            | AC6  |
| V <sub>DD</sub>             | C11 | V <sub>DD</sub> | AA2  | V <sub>SS</sub> | E3  | V <sub>SS</sub>            | AC17 |
| V <sub>DD</sub>             | C18 | V <sub>DD</sub> | AA26 | V <sub>SS</sub> | E26 | V <sub>SS</sub>            | AD4  |
| V <sub>DD</sub>             | C22 | V <sub>DD</sub> | AB23 | V <sub>SS</sub> | F23 | V <sub>SS</sub>            | AD9  |
| V <sub>DD</sub>             | C23 | V <sub>DD</sub> | AC2  | V <sub>SS</sub> | G1  | V <sub>SS</sub>            | AD11 |
| V <sub>DD</sub>             | D2  | V <sub>DD</sub> | AC3  | V <sub>SS</sub> | G2  | V <sub>SS</sub>            | AD13 |
| V <sub>DD</sub>             | D5  | V <sub>DD</sub> | AC7  | V <sub>SS</sub> | G4  | V <sub>SS</sub>            | AD17 |
| V <sub>DD</sub>             | D12 | V <sub>DD</sub> | AC10 | V <sub>SS</sub> | G25 | V <sub>SS</sub>            | AD21 |
| V <sub>DD</sub>             | D14 | V <sub>DD</sub> | AC14 | V <sub>SS</sub> | G26 | V <sub>SS</sub>            | AE11 |
| V <sub>DD</sub>             | D16 | V <sub>DD</sub> | AC19 | V <sub>SS</sub> | J4  | V <sub>SS</sub>            | AE13 |
| V <sub>DD</sub>             | F2  | V <sub>DD</sub> | AC25 | V <sub>SS</sub> | K4  | V <sub>SS</sub>            | AE23 |
| V <sub>DD</sub>             | F3  | V <sub>DD</sub> | AC26 | V <sub>SS</sub> | L3  | V <sub>SS</sub>            | AF5  |
| V <sub>DD</sub>             | F4  | V <sub>DD</sub> | AD5  | V <sub>SS</sub> | L4  | V <sub>SS</sub>            | AF7  |
| V <sub>DD</sub>             | F25 | V <sub>DD</sub> | AD7  | V <sub>SS</sub> | L24 | V <sub>SS</sub>            | AF10 |
| V <sub>DD</sub>             | H2  | V <sub>DD</sub> | AD10 | V <sub>SS</sub> | L25 | V <sub>SS</sub>            | AF16 |
| V <sub>DD</sub>             | H24 | V <sub>DD</sub> | AD15 | V <sub>SS</sub> | N23 | V <sub>SS</sub>            | AF19 |
| V <sub>DD</sub>             | H25 | V <sub>DD</sub> | AD19 | V <sub>SS</sub> | P3  | V <sub>SS</sub>            | AF20 |
| V <sub>DD</sub>             | H26 | V <sub>DD</sub> | AD22 | V <sub>SS</sub> | P4  | V <sub>SS</sub>            | AF23 |
| V <sub>DD</sub>             | J2  | V <sub>DD</sub> | AE12 | V <sub>SS</sub> | P23 | $\overline{\text{VSYNC0}}$ | G24  |
| V <sub>DD</sub>             | K2  | V <sub>DD</sub> | AE18 | V <sub>SS</sub> | R1  | $\overline{\text{VSYNC1}}$ | G23  |
| V <sub>DD</sub>             | L1  | V <sub>DD</sub> | AF8  | V <sub>SS</sub> | R4  | $\overline{\text{W}}$      | C19  |
| V <sub>DD</sub>             | M1  | V <sub>DD</sub> | AF12 | V <sub>SS</sub> | T26 | $\overline{\text{XPT0}}$   | K26  |
| V <sub>DD</sub>             | M23 | V <sub>DD</sub> | AF17 | V <sub>SS</sub> | U1  | $\overline{\text{XPT1}}$   | L23  |
| V <sub>DD</sub>             | N3  | V <sub>DD</sub> | AF21 | V <sub>SS</sub> | U2  | $\overline{\text{XPT2}}$   | R23  |
| V <sub>DD</sub>             | N4  |                 |      |                 |     |                            |      |

# TMS320C80 DIGITAL SIGNAL PROCESSOR

SPRS023B – JULY 1994 – REVISED OCTOBER 1997

## Terminal Functions

| TERMINAL NAME   | TYPE† | DESCRIPTION  |
|---|-------|--|
| <b>LOCAL MEMORY INTERFACE</b>   |       |  |
| A31–A0  | O     | Address bus. A31–A0 output the 32-bit byte address of the external memory cycle. The address can be multiplexed for DRAM accesses.   |
| AS2–AS0   | I     | Address-shift selection. AS2–AS0 determine how the column address appears on the address bus. Eight shift values are supported, including zero.  |
| BS1–BS0   | I     | Bus-size selection. BS1–BS0 indicate the bus size of the memory or other device being accessed, allowing dynamic bus sizing for data buses less than 64-bits wide.   |
| CT2–CT0   | I     | Cycle-timing selection. CT2–CT0 signals determine the timing of the current memory access.   |
| D63–D0  | I/O   | Data bus. D63–D0 transfer up to 64 bits of data per memory cycle into or out of the 'C80.  |
| $\overline{\text{DBEN}}$  | O     | Data-buffer enable. $\overline{\text{DBEN}}$ drives the active-low output-enables of bi-directional transceivers that can be used to buffer input and output data on D63–D0.   |
| $\overline{\text{DDIN}}$  | O     | Data-direction indicator. $\overline{\text{DDIN}}$ indicates the direction of the data that passes through the transceivers. When $\overline{\text{DDIN}}$ is low, the transfer is from external memory into the 'C80.   |
| $\overline{\text{FAULT}}$   | I     | Fault. $\overline{\text{FAULT}}$ is driven low by external circuitry to inform the 'C80 that a fault has occurred on the current memory row-access.  |
| PS3–PS0   | I     | Page-size indication. PS3–PS0 indicate the page size of the memory device(s) being accessed by the current cycle. The 'C80 uses this information to determine when to begin a new row-access.  |
| READY   | I     | Ready. READY indicates that the external device is ready to complete the memory cycle. READY is driven low by external circuitry to insert wait states into a memory cycle.  |
| $\overline{\text{RL}}$  | O     | Row latch. The high-to-low transition of $\overline{\text{RL}}$ can be used to latch the valid 32-bit byte address that is present on A31–A0.  |
| $\overline{\text{RETRY}}$   | I     | Retry. $\overline{\text{RETRY}}$ is driven low by external circuitry to indicate that the addressed memory is busy. The 'C80 memory cycle is rescheduled.  |
| STATUS5–STATUS0   | O     | Status code. At row time, STATUS5–STATUS0 indicate the type of cycle being performed. At column time, they identify the processor and type of request that initiated the cycle.  |
| $\overline{\text{UTIME}}$   | I     | User-timing selection. $\overline{\text{UTIME}}$ causes the timing of $\overline{\text{RAS}}$ and $\overline{\text{CAS}}/\text{DQM7}–\overline{\text{CAS}}/\text{DQM0}$ to be modified so that custom memory timings can be generated. During reset, $\overline{\text{UTIME}}$ selects the endian mode in which the 'C80 operates. |
| <b>DRAM, VRAM, AND SDRAM CONTROL</b>                                  |       |  |
| $\overline{\text{CAS}}/\text{DQM7}–\overline{\text{CAS}}/\text{DQM0}$ | O     | Column-address strobes. $\overline{\text{CAS}}/\text{DQM7}–\overline{\text{CAS}}/\text{DQM0}$ drive the $\overline{\text{CAS}}$ inputs of DRAMs and VRAMs, or the DQM input of SDRAMs. The eight strobes provide byte-write access to memory.  |
| DSF   | O     | Special function. DSF selects special VRAM functions such as block-write, load color register, split-register transfer, and SGRAM block write.   |
| $\overline{\text{RAS}}$   | O     | Row-address strobe. $\overline{\text{RAS}}$ drives the $\overline{\text{RAS}}$ inputs of DRAMs, VRAMs, and SDRAMs.   |
| $\overline{\text{TRG}}/\overline{\text{CAS}}$                         | O     | Transfer/output enable or column-address strobe. $\overline{\text{TRG}}/\overline{\text{CAS}}$ is used as an output-enable for DRAMs and VRAMs, and also as a transfer-enable for VRAMs. $\overline{\text{TRG}}/\overline{\text{CAS}}$ also drives the $\overline{\text{CAS}}$ inputs of SDRAMs.                                   |
| $\overline{\text{W}}$   | O     | Write enable. $\overline{\text{W}}$ is driven low before $\overline{\text{CAS}}$ during write cycles. $\overline{\text{W}}$ controls the direction of the transfer during VRAM transfer cycles.  |

† I = input, O = output, Z = high impedance



### Terminal Functions (Continued)

| TERMINAL<br>NAME  | TYPE† | DESCRIPTION   |
|---|-------|---|
| <b>HOST INTERFACE</b>   |       |   |
| $\overline{\text{HACK}}$  | O     | Host acknowledge. The 'C80 drives $\overline{\text{HACK}}$ output low following an active $\overline{\text{HREQ}}$ to indicate that it has driven the local-memory-bus signals to the high-impedance state and is relinquishing the bus. $\overline{\text{HACK}}$ is driven high asynchronously following $\overline{\text{HREQ}}$ being detected inactive, and then the 'C80 resumes driving the bus.  |
| $\overline{\text{HREQ}}$  | I     | Host request. An external device drives $\overline{\text{HREQ}}$ low to request ownership of the local-memory bus. When $\overline{\text{HREQ}}$ is high, the 'C80 owns and drives the bus. $\overline{\text{HREQ}}$ is synchronized internally to the 'C80's internal clock. Also, $\overline{\text{HREQ}}$ is used at reset to determine the power-up state of the MP. If $\overline{\text{HREQ}}$ is low at the rising edge of $\overline{\text{RESET}}$ , the MP comes up running. If $\overline{\text{HREQ}}$ is high, the MP remains halted until the first interrupt occurrence on $\overline{\text{EINT3}}$ . |
| REQ1, REQ0  | O     | Internal cycle request. REQ1 and REQ0 provide a two-bit code indicating the highest-priority memory-cycle request that is being received by the TC. External logic can monitor REQ1 and REQ0 to determine if it is necessary to relinquish the local-memory bus to the 'C80.  |
| <b>SYSTEM CONTROL</b>   |       |   |
| CLKIN   | I     | Input clock. CLKIN generates the internal 'C80 clocks to which all processor functions (except the frame timers) are synchronous.   |
| CLKOUT  | O     | Local output clock. CLKOUT provides a way to synchronize external circuitry to internal timings. All 'C80 output signals (except the VC signals) are synchronous to this clock.   |
| $\overline{\text{EINT1}}$ , $\overline{\text{EINT2}}$ , $\overline{\text{EINT3}}$ | I     | Edge-triggered interrupts. $\overline{\text{EINT1}}$ , $\overline{\text{EINT2}}$ and $\overline{\text{EINT3}}$ allow external devices to interrupt the master processor (MP) on one of three interrupt levels ( $\overline{\text{EINT1}}$ is the highest priority). The interrupts are rising-edge triggered. $\overline{\text{EINT3}}$ also serves as an unhalt signal. If the MP is powered-up halted, the first rising edge on $\overline{\text{EINT3}}$ causes the MP to unhalt and fetch its reset vector (the $\overline{\text{EINT3}}$ interrupt-pending bit is not set in this case).                         |
| $\overline{\text{LINT4}}$   | I     | Level-triggered interrupt. $\overline{\text{LINT4}}$ provides an active-low level-triggered interrupt to the MP. Its priority falls below that of the edge-triggered interrupts. Any interrupt request should remain low until it is recognized by the 'C80.  |
| $\overline{\text{RESET}}$   | I     | Reset. $\overline{\text{RESET}}$ is driven low to reset the 'C80 (all processors). During reset, all internal registers are set to their initial state and all outputs are driven to their inactive or high-impedance levels. During the rising edge of $\overline{\text{RESET}}$ , the MP reset mode and the 'C80's operating endian mode are determined by the levels of $\overline{\text{HREQ}}$ and $\overline{\text{UTIME}}$ pins, respectively.   |
| $\overline{\text{XPT2}}$ – $\overline{\text{XPT0}}$                               | I     | External packet transfer. $\overline{\text{XPT2}}$ – $\overline{\text{XPT0}}$ are used by external devices to request a high-priority XPT by the TC.  |
| <b>EMULATION CONTROL</b>  |       |   |
| EMU0, EMU1‡   | I/O   | Emulation pins. EMU0 and EMU1 are used to support emulation host interrupts, special functions targeted at a single processor, and multiprocessor halt-event communications.  |
| TCK‡  | I     | Test clock. TCK provides the clock for the 'C80 IEEE-1149.1 logic, allowing it to be compatible with other IEEE-1149.1 devices, controllers, and test equipment designed for different clock rates.   |
| TDI‡  | I     | Test data input. TDI provides input data for all IEEE-1149.1 instructions and data scans of the 'C80.   |
| TDO   | O     | Test data output. TDO provides output data for all IEEE-1149.1 instructions and data scans of the 'C80.   |
| TMS‡  | I     | Test-mode select. TMS controls the IEEE-1149.1 state machine.   |
| $\overline{\text{TRST}}§$   | I     | Test reset. $\overline{\text{TRST}}$ resets the 'C80 IEEE-1149.1 module. When low, all boundary-scan logic is disabled, allowing normal 'C80 operation.   |

† I = input, O = output, Z = high impedance

‡ This pin has an internal pullup and can be left unconnected during normal operation.

§ This pin has an internal pulldown and can be left unconnected during normal operation.

# TMS320C80 DIGITAL SIGNAL PROCESSOR

SPRS023B – JULY 1994 – REVISED OCTOBER 1997

## Terminal Functions (Continued)

| TERMINAL NAME  | TYPE† | DESCRIPTION   |
|--|-------|---|
| <b>VIDEO INTERFACE</b>   |       |   |
| CAREA0, CAREA1   | O     | Composite area. CAREA0 and CAREA1 define a special area such as an overscan boundary. This area represents the logical OR of the internal horizontal and vertical area signals.   |
| $\overline{\text{CBLNK0}} / \overline{\text{VBLNK0}}$ ,<br>$\overline{\text{CBLNK1}} / \overline{\text{VBLNK1}}$ | O     | Composite blanking/vertical blanking. Each of $\overline{\text{CBLNK0}} / \overline{\text{VBLNK0}}$ and $\overline{\text{VBLNK1}}$ provides one of two blanking functions, depending on the configuration of the CSYNC/HBLNK pin:<br>Composite blanking disables pixel display/capture during both horizontal and vertical retrace periods and is enabled when CSYNC is selected for composite sync video systems.<br>Vertical blanking disables pixel display/capture during vertical retrace periods and is enabled when HBLNK is selected for separate-sync video systems.<br>Following reset, $\overline{\text{CBLNK0}} / \overline{\text{VBLNK0}}$ and $\overline{\text{CBLNK1}} / \overline{\text{VBLNK1}}$ are configured as $\overline{\text{CBLNK0}}$ and $\overline{\text{CBLNK1}}$ , respectively.   |
| $\overline{\text{CSYNC0}} / \overline{\text{HBLNK0}}$ ,<br>$\overline{\text{CSYNC1}} / \overline{\text{HBLNK1}}$ | I/O/Z | Composite sync/horizontal blanking. $\overline{\text{CSYNC0}} / \overline{\text{HBLNK0}}$ and $\overline{\text{CSYNC1}} / \overline{\text{HBLNK1}}$ can be programmed for one of two functions:<br>Composite sync is for use on composite-sync video systems and can be programmed as an input, output, or high-impedance signal. As an input, the 'C80 extracts horizontal and vertical sync information from externally generated active-low sync pulses. As an output, the active-low composite sync pulses are generated from either external HSYNC and VSYNC signals or the 'C80's internal video timers. In the high-impedance state, the pin is neither driven nor allowed to drive circuitry.<br>Horizontal blank disables pixel display/capture during horizontal retrace periods in separate-sync video systems and can be used as an output only.<br>Immediately following reset, $\overline{\text{CSYNC0}} / \overline{\text{HBLNK0}}$ and $\overline{\text{CSYNC1}} / \overline{\text{HBLNK1}}$ are configured as high-impedance $\overline{\text{CSYNC0}}$ and $\overline{\text{CSYNC1}}$ , respectively. |
| FCLK0, FCLK1   | I     | Frame clock. FCLK0 and FCLK1 are derived from the external video system's dotclock and are used to drive the 'C80 video logic for frame timer 0 and frame timer 1.  |
| $\overline{\text{HSYNC0}}$ ,<br>$\overline{\text{HSYNC1}}$   | I/O/Z | Horizontal sync. $\overline{\text{HSYNC0}}$ and $\overline{\text{HSYNC1}}$ control the video system. They can be programmed as input, output, or high impedance signals. As an input, HSYNC synchronizes the video timer to externally generated horizontal sync pulses. As an output, HSYNC is an active-low horizontal sync pulse generated by the 'C80 on-chip frame timer. In the high-impedance state, the pin is not driven, and no internal synchronization is allowed to occur. Immediately following reset, $\overline{\text{HSYNC0}}$ and $\overline{\text{HSYNC1}}$ are in the high-impedance state.   |
| SCLK0, SCLK1   | I     | Serial-data clock. SCLK0 and SCLK1 are used by the 'C80 SRT controller to track the VRAM tap point when using midline reload. SCLK0 and SCLK1 should be the same signals that clock the serial register on the VRAMs controlled by frame timer 0 and frame timer 1, respectively.   |
| $\overline{\text{VSYNC0}}$ ,<br>$\overline{\text{VSYNC1}}$   | I/O/Z | Vertical sync. $\overline{\text{VSYNC0}}$ and $\overline{\text{VSYNC1}}$ control the video system. They can be programmed as inputs, outputs, or high-impedance signals. As inputs, $\overline{\text{VSYNCx}}$ synchronizes the frame timer to externally generated vertical-sync pulses. As outputs, $\overline{\text{VSYNCx}}$ are active-low vertical-sync pulses generated by the 'C80 on-chip frame timer. In the high-impedance state, the pin is not driven and no internal synchronization is allowed to occur. Immediately following reset, $\overline{\text{VSYNCx}}$ is in the high-impedance state.   |
| <b>POWER</b>   |       |   |
| VSS‡   | I     | Ground. Electrical ground inputs  |
| VDD‡   | I     | Power. Nominal 3.3-V power supply inputs  |
| <b>MISCELLANEOUS</b>   |       |   |
| No Connect   |       | No connect serves as an alignment key and must be left unconnected.   |
| FF2–FF1  |       | FF2–FF1 (GF package only) are reserved for factory use and should be left unconnected.  |

† I = input, O = output, Z = high-impedance

‡ For proper operation, all VDD and VSS pins must be connected externally.



architecture

Figure 1 shows the major components of the 'C80: the master processor (MP), the parallel digital signal processors (PPs), the transfer controller (TC), the video controller (VC), and the IEEE-1149.1 emulation interface. Shared access to on-chip RAM is achieved through the crossbar. Crossbar connections are represented by  $\circ$ . Each PP can perform three accesses per cycle through its local (L), global (G), and instruction (I) ports. The MP can access two RAMs per cycle through its crossbar/data (C/D) and instruction (I) ports, and the TC can access one RAM through its crossbar interface. Up to 15 simultaneous accesses are supported in each cycle. Addresses can be changed every cycle, allowing the crossbar matrix to be changed on a cycle-by-cycle basis. Contention between processors for the same RAM in the same cycle is resolved by a round-robin priority scheme. In addition to the crossbar, a 32-bit datapath exists between the MP and the TC and VC. This allows the MP to access TC and VC on-chip registers that are memory mapped into the MP memory space.

The 'C80 has a 4G-byte address space as shown in Figure 2. The lower 32M bytes are used to address internal RAM and memory-mapped registers.

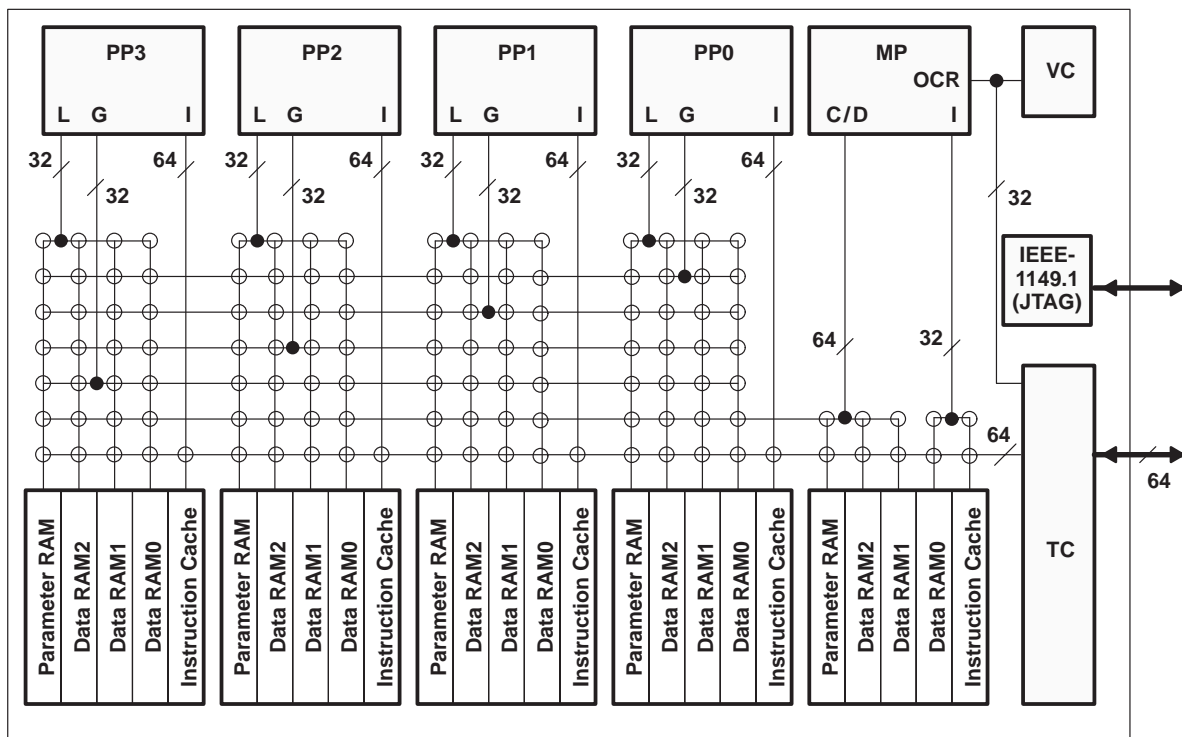

Figure 1. Block Diagram Showing Datapaths

# TMS320C80 DIGITAL SIGNAL PROCESSOR

SPRS023B – JULY 1994 – REVISED OCTOBER 1997

## architecture (continued)

|                             |            |   |            |
|-----------------------------|------------|---|------------|
| PP0 Data RAM0<br>(2K Bytes) | 0x00000000 | Reserved<br>(51 200 Bytes)                | 0x01003800 |
| PP0 Data RAM1<br>(2K Bytes) | 0x000007FF |   | 0x0100FFFF |
| PP1 Data RAM0<br>(2K Bytes) | 0x00000800 | MP Parameter RAM<br>(2K Bytes)            | 0x01010000 |
| PP1 Data RAM1<br>(2K Bytes) | 0x00000FFF | Reserved<br>(8 327 168 Bytes)             | 0x010107FF |
| PP2 Data RAM0<br>(2K Bytes) | 0x00001000 |   | 0x01010800 |
| PP2 Data RAM1<br>(2K Bytes) | 0x000017FF | PP0 Instruction Cache<br>(2K Bytes)       | 0x018017FF |
| PP2 Data RAM2<br>(2K Bytes) | 0x00001800 |   | 0x01801800 |
| Reserved<br>(16K Bytes)     | 0x00001FFF | Reserved<br>(6K Bytes)                    | 0x01801FFF |
| PP0 Data RAM2<br>(2K Bytes) | 0x00002000 |   | 0x01802000 |
| Reserved<br>(2K Bytes)      | 0x000027FF | PP1 Instruction Cache<br>(2K Bytes)       | 0x018037FF |
| Reserved<br>(2K Bytes)      | 0x00002800 | Reserved<br>(6K Bytes)                    | 0x01803800 |
| Reserved<br>(2K Bytes)      | 0x00002FFF |   | 0x01803FFF |
| Reserved<br>(2K Bytes)      | 0x00003000 | PP2 Instruction Cache<br>(2K Bytes)       | 0x01804000 |
| Reserved<br>(2K Bytes)      | 0x000037FF | Reserved<br>(6K Bytes)                    | 0x018057FF |
| Reserved<br>(2K Bytes)      | 0x00003800 |   | 0x01805800 |
| Reserved<br>(2K Bytes)      | 0x00003FFF | Reserved<br>(6K Bytes)                    | 0x01805FFF |
| Reserved<br>(2K Bytes)      | 0x00004000 |   | 0x01806000 |
| Reserved<br>(2K Bytes)      | 0x00007FFF | PP3 Instruction Cache<br>(2K Bytes)       | 0x018077FF |
| Reserved<br>(2K Bytes)      | 0x00008000 | Reserved<br>(32K Bytes)                   | 0x01807800 |
| Reserved<br>(2K Bytes)      | 0x000087FF |   | 0x01807FFF |
| Reserved<br>(2K Bytes)      | 0x00008800 | Reserved<br>(28K Bytes)                   | 0x01808000 |
| Reserved<br>(2K Bytes)      | 0x00008FFF |   | 0x01808FFF |
| Reserved<br>(2K Bytes)      | 0x00009000 | MP Data Cache<br>(4K Bytes)               | 0x01810000 |
| Reserved<br>(2K Bytes)      | 0x000097FF |   | 0x01810FFF |
| Reserved<br>(2K Bytes)      | 0x00009800 | Reserved<br>(28K Bytes)                   | 0x01811000 |
| Reserved<br>(2K Bytes)      | 0x00009FFF |   | 0x01817FFF |
| Reserved<br>(2K Bytes)      | 0x0000A000 | MP Instruction Cache<br>(4K Bytes)        | 0x01818000 |
| Reserved<br>(2K Bytes)      | 0x0000A7FF |   | 0x01818FFF |
| Reserved<br>(2K Bytes)      | 0x0000A800 | Reserved<br>(28K Bytes)                   | 0x01819000 |
| Reserved<br>(2K Bytes)      | 0x0000AFFF |   | 0x01819FFF |
| Reserved<br>(2K Bytes)      | 0x0000B000 | Memory-Mapped TC Registers<br>(512 Bytes) | 0x01820000 |
| Reserved<br>(2K Bytes)      | 0x0000B7FF |   | 0x018201FF |
| Reserved<br>(2K Bytes)      | 0x0000B800 | Memory-Mapped VC Registers<br>(512 Bytes) | 0x01820200 |
| Reserved<br>(2K Bytes)      | 0x0000BFFF |   | 0x018203FF |
| Reserved<br>(2K Bytes)      | 0x0000C000 | Reserved<br>(8 327 168 Bytes)             | 0x01820400 |
| Reserved<br>(2K Bytes)      | 0x0000C7FF |   | 0x01FFFFF  |
| Reserved<br>(2K Bytes)      | 0x0000C800 | External Memory<br>(4064M Bytes)          | 0x02000000 |
| Reserved<br>(2K Bytes)      | 0x0000CFFF |   | 0xFFFFF    |
| Reserved<br>(2K Bytes)      | 0x0000D000 |   |            |
| Reserved<br>(2K Bytes)      | 0x0000D7FF |   |            |
| Reserved<br>(2K Bytes)      | 0x0000D800 |   |            |
| Reserved<br>(2K Bytes)      | 0x0000DFFF |   |            |
| Reserved<br>(2K Bytes)      | 0x0000E000 |   |            |
| Reserved<br>(2K Bytes)      | 0x0000E7FF |   |            |
| Reserved<br>(2K Bytes)      | 0x0000E800 |   |            |
| Reserved<br>(2K Bytes)      | 0x0000EFFF |   |            |
| Reserved<br>(2K Bytes)      | 0x0000F000 |   |            |
| Reserved<br>(2K Bytes)      | 0x0000F7FF |   |            |
| Reserved<br>(2K Bytes)      | 0x0000F800 |   |            |
| Reserved<br>(2K Bytes)      | 0x0000FFFF |   |            |

Figure 2. Memory Map



---

## master processor (MP) architecture

The master processor (MP) is a 32-bit RISC processor with an integral IEEE-754 floating-point unit. The MP is designed for effective execution of C code and is capable of performing at well over 130K dhrystones/s. Major tasks which the MP typically performs are:

- Task control and user interface
- Information processing and analysis
- IEEE-754 floating point (including graphics transforms)

## MP functional block diagram

Figure 3 shows a block diagram of the master processor. Key features of the MP include:

- 32-bit RISC processor
  - Load/store architecture
  - Three operand arithmetic and logical instructions
- 4K-byte instruction cache and 4K-byte data cache
  - Four-way set associative
  - LRU replacement
  - Data writeback
- 2K-byte non-cached parameter RAM
- Thirty-one 32-bit general-purpose registers
- Register and accumulator scoreboard
- 15-bit or 32-bit immediate constants
- 32-bit byte addressing
- Scalable timer
- Leftmost-one and rightmost-one logic
- IEEE-754 floating-point hardware
  - Four double-precision floating-point vector accumulators
  - Vector floating-point instructions
    - Floating-point operation and parallel load or store
    - Multiply and accumulate
- High performance
  - 60 million instructions per second (MIPS)
  - 120 million floating-point operations per second (MFLOPS)
  - Over 130K dhrystones/s

MP functional block diagram (continued)

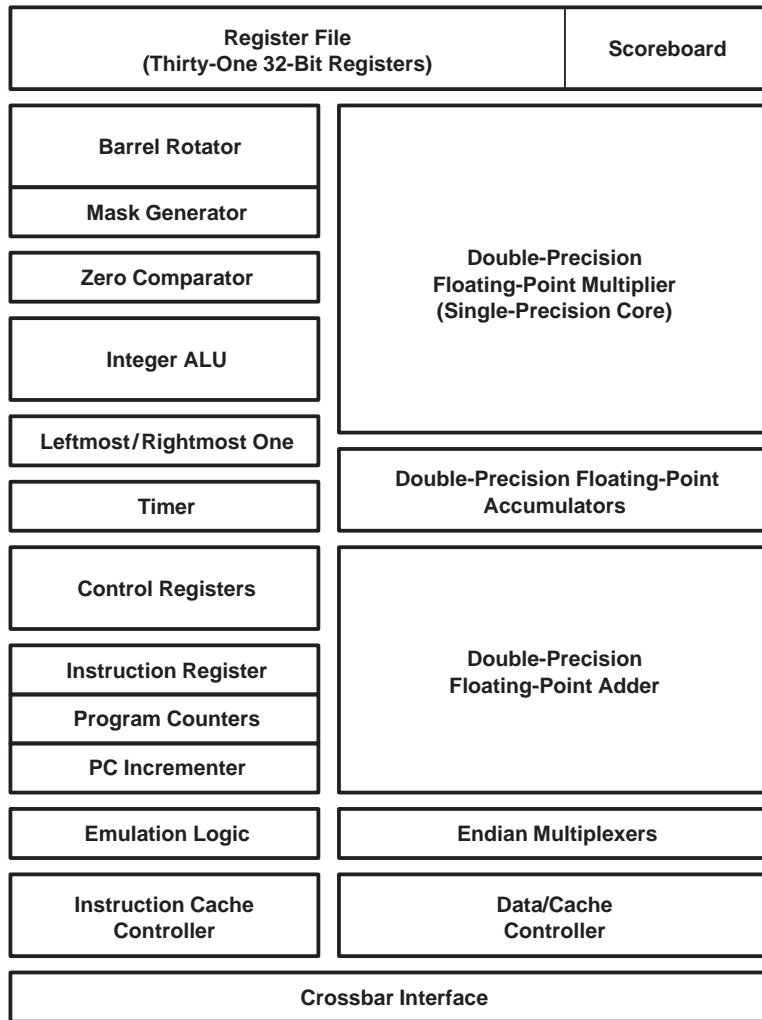

Figure 3. MP Block Diagram

MP general-purpose registers

The MP contains 31 32-bit general-purpose registers, R1–R31. Register R0 always reads as zero and writes to it are discarded. Double precision values are always stored in an even-odd register pair with the higher numbered register always holding the sign bit and exponent. The R0/R1 pair is not available for this use. A scoreboard keeps track of which registers are awaiting loads or the result of a previous instruction and stalls the instruction pipeline until the register contains valid data. As a recommended software convention, typically R1 is used as a stack pointer and R31 as a return-address link register.

Figure 4 shows the MP general-purpose registers.



# TMS320C80 DIGITAL SIGNAL PROCESSOR

SPRS023B – JULY 1994 – REVISED OCTOBER 1997

## MP general-purpose registers (continued)

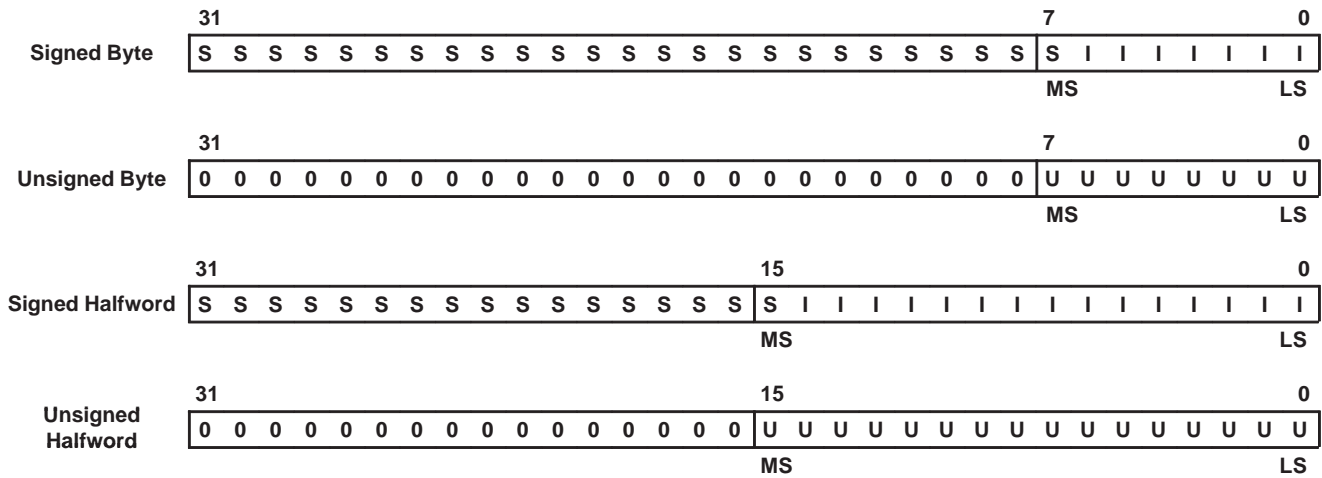

Figure 6. MP Register 8-Bit and 16-Bit Data

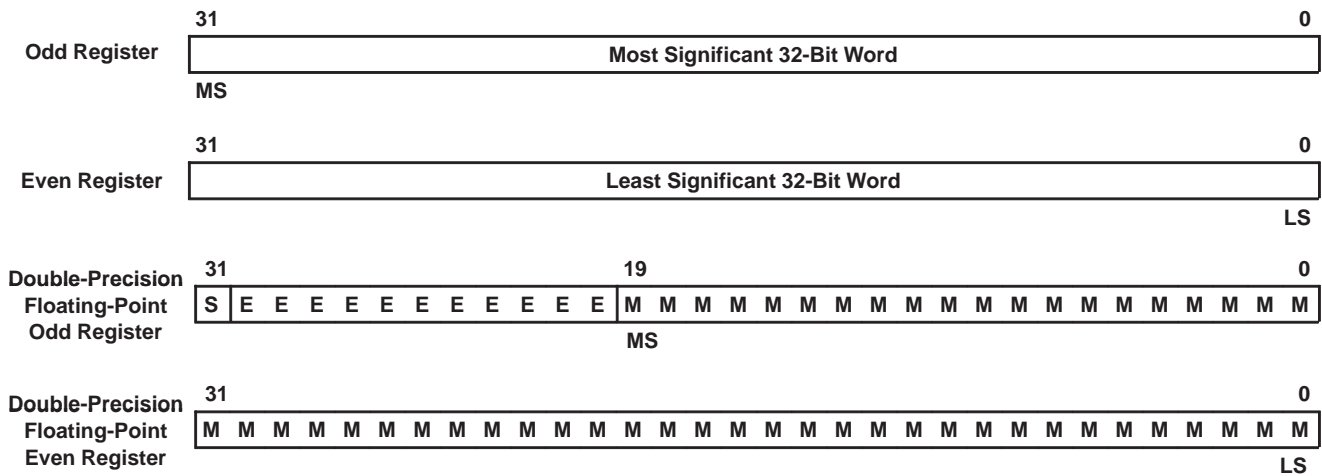

Figure 7. MP Register 64-Bit Data

## MP double-precision floating-point accumulators

There are four double-precision floating-point registers (see Figure 8) to accumulate intermediate floating-point results.

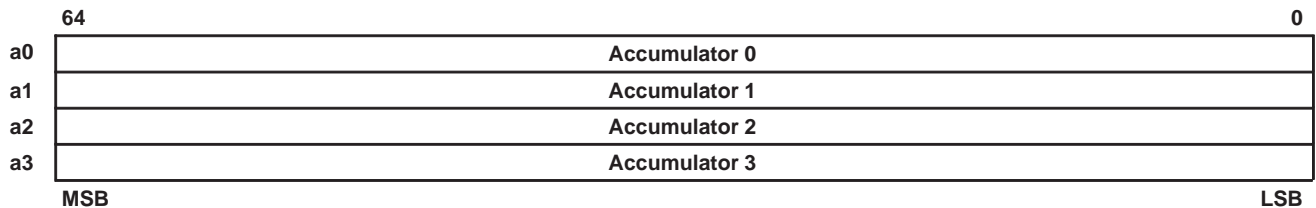

Figure 8. Double-Precision Floating-Point Accumulators



## MP control registers

In addition to the general-purpose registers, there are a number of control registers that are used to represent the state of the processor. Table 1 shows the control register numbers of the accessible registers.

**Table 1. Control Register Numbers**

| NO.    | NAME    | DESCRIPTION                   | NO.             | NAME     | DESCRIPTION                        |
|--------|---------|-------------------------------|-----------------|----------|------------------------------------|
| 0x0000 | EPC     | Exception Program Counter     | 0x0015–0x001F   | —        | Reserved                           |
| 0x0001 | EIP     | Exception Instruction Pointer | 0x0020          | SYSSTK   | System Stack Pointer               |
| 0x0002 | CONFIG  | Configuration                 | 0x0021          | SYSTMP   | System Temporary Register          |
| 0x0003 | —       | Reserved                      | 0x0022–0x002F   | —        | Reserved                           |
| 0x0004 | INTPEN  | Interrupt Pending             | 0x0030          | MPC      | Emulator Exception Program Cntr    |
| 0x0005 | —       | Reserved                      | 0x0031          | MIP      | Emulator Exception Instruction Ptr |
| 0x0006 | IE      | Interrupt Enable              | 0x0032          | —        | Reserved                           |
| 0x0007 | —       | Reserved                      | 0x0033          | ECOMCNTL | Emulator Communication Control     |
| 0x0008 | FPST    | Floating-Point Status         | 0x0034          | ANASTAT  | Emulation Analysis Status Reg      |
| 0x0009 | —       | Reserved                      | 0x0035–0x0038   | —        | Reserved                           |
| 0x000A | PPERROR | PP Error Indicators           | 0x0039          | BRK1     | Emulation Breakpoint 1 Reg.        |
| 0x000B | —       | Reserved                      | 0x003A          | BRK2     | Emulation Breakpoint 2 Reg.        |
| 0x000C | —       | Reserved                      | 0x003B–0x01FF   | —        | Reserved                           |
| 0x000D | PKTREQ  | Packet Request Register       | 0x0200 – 0x020F | ITAG0–15 | Instruction Cache Tags 0 to 15     |
| 0x000E | TCOUNT  | Current Counter Value         | 0x0300          | ILRU     | Instruction Cache LRU Register     |
| 0x000F | TSCALE  | Counter Reload Value          | 0x0400–0x040F   | DTAG0–15 | Data Cache Tags 0 to 15            |
| 0x0010 | FLTOP   | Faulting Operation            | 0x0500          | DLRU     | Data Cache LRU Register            |
| 0x0011 | FLTADR  | Faulting Address              | 0x4000          | IN0P     | Vector Load Pointer 0              |
| 0x0012 | FLT TAG | Faulting Tag                  | 0x4001          | IN1P     | Vector Load Pointer 1              |
| 0x0013 | FLTDTL  | Faulting Data (low)           | 0x4002          | OUTP     | Vector Store Pointer               |
| 0x0014 | FLTDTH  | Faulting Date (high)          |                 |          |                                    |

## MP pipeline registers

The MP uses a three-stage fetch, execute, access (FEA) pipeline. The primary pipeline registers are manipulated implicitly by branch and trap instructions and are not accessible by the user. The exception and emulation pipeline registers are user accessible as control registers. All pipeline registers are 32 bits.

|                      | Program Execution Mode |           |           |
|----------------------|------------------------|-----------|-----------|
|                      | Normal                 | Exception | Emulation |
| Program Counter      | PC                     | EPC       | MPC       |
| Instruction Pointer  | IP                     | EIP       | MIP       |
| Instruction Register | IR                     |           |           |

- Instruction register (IR) contains the instruction being executed.
- Instruction pointer (IP) points to the instruction being executed.
- Program counter (PC) points to the instruction being fetched.
- Exception/emulator instruction pointer (EIP/MIP) points to the instruction that would have been executed had the exception / emulation trap not occurred.
- Exception/emulator program counter (EPC/MPC) points to the instruction to be fetched on returning from the exception/emulation trap.

**Figure 9. MP FEA Pipeline Registers**

# TMS320C80 DIGITAL SIGNAL PROCESSOR

SPRS023B – JULY 1994 – REVISED OCTOBER 1997

## configuration (CONFIG) register (0x0002)

The CONFIG register controls or reflects the state of certain options as shown in Figure 10.

|    |    |    |    |    |          |    |    |    |    |      |    |    |    |    |          |    |    |         |    |    |          |   |   |   |   |   |   |   |   |   |   |
|----|----|----|----|----|----------|----|----|----|----|------|----|----|----|----|----------|----|----|---------|----|----|----------|---|---|---|---|---|---|---|---|---|---|
| 31 | 30 | 29 | 28 | 27 | 26       | 25 | 24 | 23 | 22 | 21   | 20 | 19 | 18 | 17 | 16       | 15 | 14 | 13      | 12 | 11 | 10       | 9 | 8 | 7 | 6 | 5 | 4 | 3 | 2 | 1 | 0 |
| E  | R  | T  | H  | X  | Reserved |    |    |    |    | Type |    |    |    |    | Reserved |    |    | Release |    |    | Reserved |   |   |   |   |   |   |   |   |   |   |

- E Endian mode; 0 = big-endian, 1 = little-endian, read only
- R PPData RAM round robin; 0 = fixed, 1 = variable, read/write
- T TC PT round robin; 0 = variable, 1 = fixed, read/write.
- H High priority MP events; 0 = disabled, 1 = enabled, read/write
- X Externally initiated packet transfers; 0 = disabled, 1 = enabled, read/write
- Type Number of PPs in device, read only
- Release TMS320C80 version number

Figure 10. CONFIG Register

## interrupt-enable (IE) register (0x0006)

The IE register contains enable bits for each of the interrupts/traps as shown in Figure 11. The global-interrupt-enable (ie) bit and the appropriate individual interrupt-enable bit must be set in order for an interrupt to occur.

|    |    |    |    |    |    |    |    |    |    |    |    |    |    |    |    |    |    |    |    |    |    |    |    |    |    |    |   |    |    |   |    |
|----|----|----|----|----|----|----|----|----|----|----|----|----|----|----|----|----|----|----|----|----|----|----|----|----|----|----|---|----|----|---|----|
| 31 | 30 | 29 | 28 | 27 | 26 | 25 | 24 | 23 | 22 | 21 | 20 | 19 | 18 | 17 | 16 | 15 | 14 | 13 | 12 | 11 | 10 | 9  | 8  | 7  | 6  | 5  | 4 | 3  | 2  | 1 | 0  |
| pe | x4 | x3 | bp | pb | pc | mi |    |    |    |    |    | p3 | p2 | p1 | p0 | io | mf |    | x2 | x1 | ti | f1 | f0 | fx | fu | fo |   | fz | fi |   | ie |

- |    |                                       |    |                                       |    |                               |
|----|---------------------------------------|----|---------------------------------------|----|-------------------------------|
| pe | PP error                              | p2 | PP2 message interrupt                 | f1 | Frame-timer 1 interrupt       |
| x4 | External interrupt 4 ( <u>LINT4</u> ) | p1 | PP1 message interrupt                 | f0 | Frame-timer 0 interrupt       |
| x3 | External interrupt 3 ( <u>EINT3</u> ) | p0 | PP0 message interrupt                 | fx | Floating-point inexact        |
| bp | Bad packet transfer                   | io | Integer overflow                      | fu | Floating-point underflow      |
| pb | Packet transfer busy                  | mf | Memory fault                          | fo | Floating-point overflow       |
| pc | Packet transfer complete              | x2 | External interrupt 2 ( <u>EINT2</u> ) | fz | Floating-point divide-by-zero |
| mi | Message (MP self) interrupt           | x1 | External interrupt 1 ( <u>EINT1</u> ) | fi | Floating-point invalid        |
| p3 | PP3 message interrupt                 | ti | MP timer interrupt                    | ie | Global-interrupt enable       |

Figure 11. IE Register

## interrupt-pending (INTPEN) register (0x0004)

The bits in INTPEN register show the current state of each interrupt/trap. Pending interrupts do not occur unless the ie bit and corresponding interrupt-enable bit are set. Software must write a 1 to the appropriate INTPEN bit to clear an interrupt. Figure 12 shows the INTPEN register locations.

|    |    |    |    |    |    |    |    |    |    |    |    |    |    |    |    |    |    |    |    |    |    |    |    |    |    |    |    |   |    |    |   |
|----|----|----|----|----|----|----|----|----|----|----|----|----|----|----|----|----|----|----|----|----|----|----|----|----|----|----|----|---|----|----|---|
| 31 | 30 | 29 | 28 | 27 | 26 | 25 | 24 | 23 | 22 | 21 | 20 | 19 | 18 | 17 | 16 | 15 | 14 | 13 | 12 | 11 | 10 | 9  | 8  | 7  | 6  | 5  | 4  | 3 | 2  | 1  | 0 |
| pe | x4 | x3 | bp | pb | pc | mi |    |    |    |    |    |    | p3 | p2 | p1 | p0 | io | mf |    | x2 | x1 | ti | f1 | f0 | fx | fu | fo |   | fz | fi |   |

Figure 12. INTPEN Register





**MP cache registers**

The ILRU and DLRU registers track least-recently-used (LRU) information for the sixteen instruction-cache and sixteen data-cache blocks. The ITAGxx registers contain block addresses and the present flags for each sub-block. DTAGxx registers are identical to ITAGxx registers but include dirty bits for each sub-block. Figure 17 shows the cache registers.

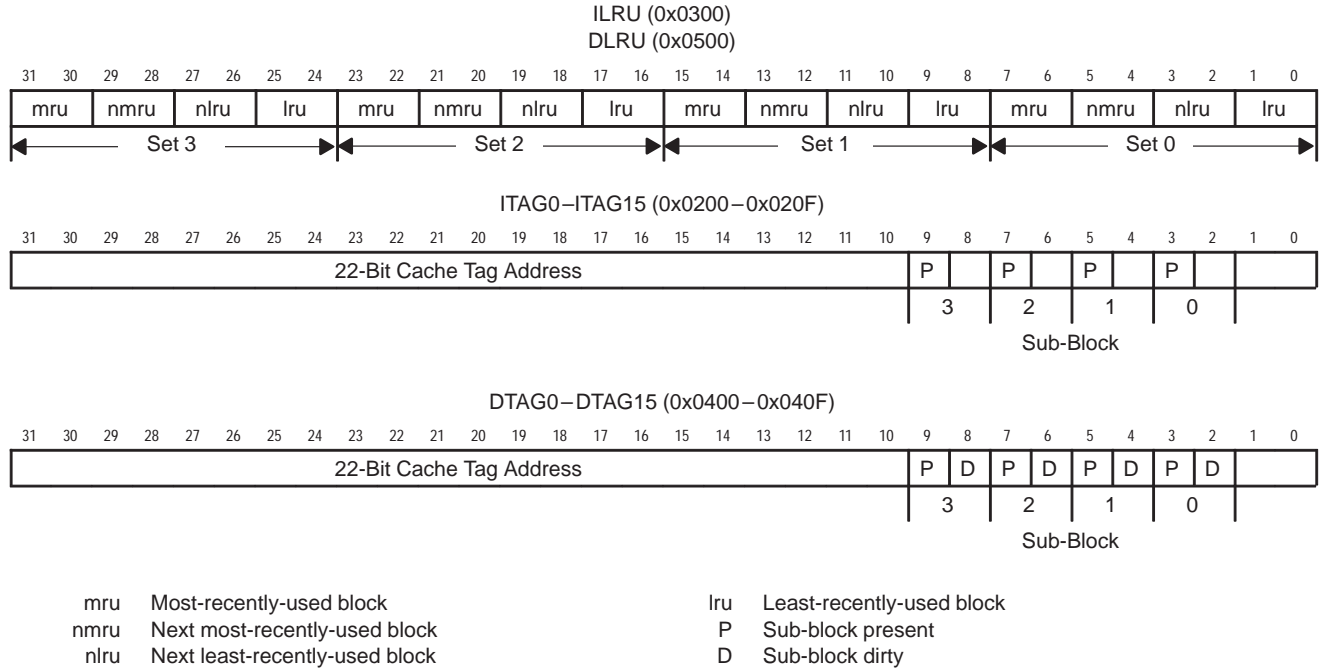

mru, nmru, nlru, and lru have the value 0, 1, 2, or 3 representing the block number and are mutually exclusive for each set.

**Figure 17. Cache Registers**

**MP cache architecture**

The MP contains two four-way set-associative, 4K caches for instructions and data. Each cache is divided into four sets with four blocks in each set. Each block represents 256 bytes of contiguous instructions or data and is aligned to a 256-byte address boundary. Each block is partitioned into four sub-blocks that each contain sixteen 32-bit words and are aligned to 64-byte boundaries within the block. Cache misses cause one sub-block to be loaded into cache. Figure 18 shows the cache architecture for one of the four sets in each cache. Figure 19 shows how addresses map into the cache using the cache tags and address bits.

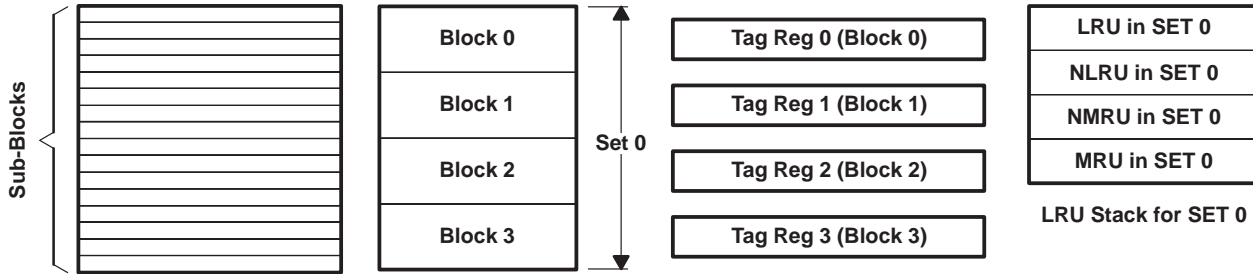

**Figure 18. MP Cache Architecture (x4 Sets)**

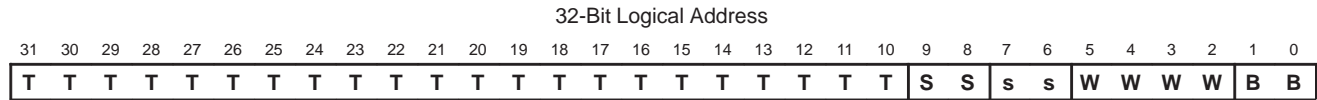

**On-Chip MP 2K Cache RAMS**

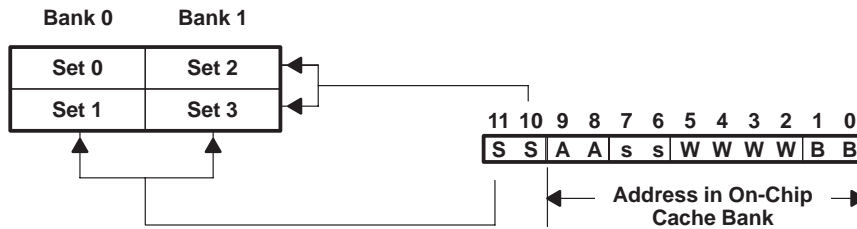

- T – Tag Address Bits
- S – Set Select Bits (0–3)
- s – Sub-Block (within block) Select (0–3)
- W – Word (within sub-block) Select (0–15)
- B – Byte (within word) Select (0–3)
- A – Block Select (which tag matched) (0–3)

**Figure 19. MP Cache Addressing**

## MP parameter RAM

The parameter RAM is a noncachable, 2K-byte, on-chip RAM which contains MP-interrupt vectors, MP-requested TC task buffers, and a general-purpose area. Figure 20 shows the parameter RAM address map.

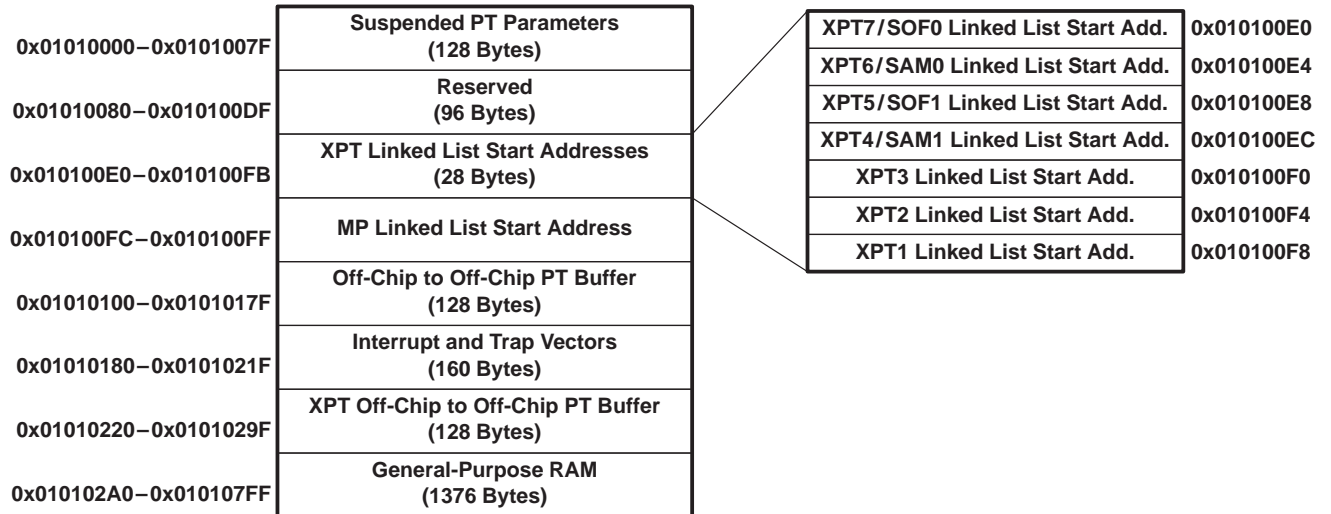

Figure 20. MP Parameter RAM

# TMS320C80 DIGITAL SIGNAL PROCESSOR

SPRS023B – JULY 1994 – REVISED OCTOBER 1997

## MP interrupt vectors

Table 2 and Table 3 show the MP interrupts and traps and their vector addresses.

**Table 2. Maskable Interrupts**

| IE BIT (TRAP#) | NAME | VECTOR ADDRESS | MASKABLE INTERRUPT                                 |
|----------------|------|----------------|--|
| 0              | ie   | 0x01010180     |  |
| 2              | fi   | 0x01010188     | Floating-point invalid                             |
| 3              | fz   | 0x0101018C     | Floating-point divide-by-zero                      |
| 5              | fo   | 0x01010194     | Floating-point overflow                            |
| 6              | fu   | 0x01010198     | Floating-point underflow                           |
| 7              | fx   | 0x0101019C     | Floating-point inexact                             |
| 8              | f0   | 0x010101A0     | Frame timer 0                                      |
| 9              | f1   | 0x010101A4     | Frame timer 1                                      |
| 10             | ti   | 0x010101A8     | MP timer   |
| 11             | x1   | 0x010101AC     | External interrupt 1 ( $\overline{\text{EINT}}1$ ) |
| 12             | x2   | 0x010101B0     | External interrupt 2 ( $\overline{\text{EINT}}2$ ) |
| 14             | mf   | 0x010101B8     | Memory fault                                       |
| 15             | io   | 0x010101BC     | Integer overflow                                   |
| 16             | p0   | 0x010101C0     | PP0 message  |
| 17             | p1   | 0x010101C4     | PP1 message  |
| 18             | p2   | 0x010101C8     | PP2 message  |
| 19             | p3   | 0x010101CC     | PP3 message  |
| 25             | mi   | 0x010101E4     | MP message   |
| 26             | pc   | 0x010101E8     | Packet transfer complete                           |
| 27             | pb   | 0x010101EC     | Packet transfer busy                               |
| 28             | bp   | 0x010101F0     | Bad packet transfer                                |
| 29             | x3   | 0x010101F4     | External interrupt 3 ( $\overline{\text{EINT}}3$ ) |
| 30             | x4   | 0x010101F8     | External interrupt 4 ( $\overline{\text{LINT}}4$ ) |
| 31             | pe   | 0x010101FC     | PP error   |

**Table 3. Nonmaskable Traps**

| TRAP NO.  | NAME | VECTOR ADDRESS           | NONMASKABLE TRAP          |
|-----------|------|--------------------------|---------------------------|
| 32        | e1   | 0x01010200               | Emulator trap1 (reserved) |
| 33        | e2   | 0x01010204               | Emulator trap2 (reserved) |
| 34        | e3   | 0x01010208               | Emulator trap3 (reserved) |
| 35        | e4   | 0x0101020C               | Emulator trap4 (reserved) |
| 36        | fe   | 0x01010210               | Floating-point error      |
| 37        |      | 0x01010214               | Reserved                  |
| 38        | er   | 0x01010218               | Illegal MP instruction    |
| 39        |      | 0x0101021C               | Reserved                  |
| 72 to 415 |      | 0x010102A0 to 0x010107FC | System or user defined    |

### MP opcode formats

The three basic classes of MP instruction opcodes are; short immediate, three register, and long immediate. Figure 21 shows the opcode structure for each class of instruction.

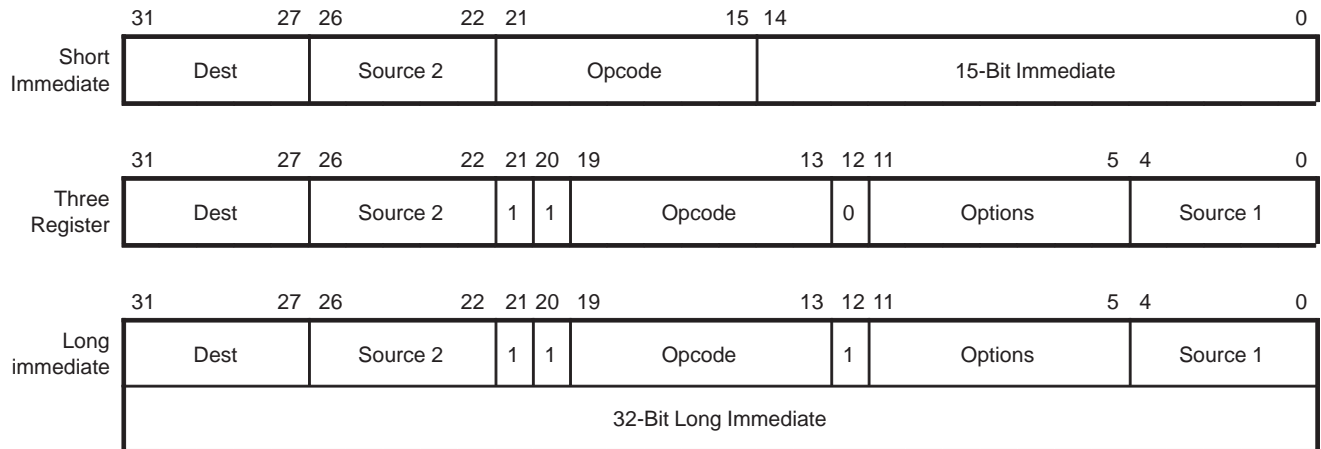

**Figure 21. MP Opcode Formats**

# TMS320C80 DIGITAL SIGNAL PROCESSOR

SPRS023B – JULY 1994 – REVISED OCTOBER 1997

## MP opcode summary

Table 4 through Table 6 show the opcode formats for the MP. Table 7 summarizes the master processor instruction set.

**Table 4. Short-Immediate Opcodes**

|          | 31     | 30 | 29 | 28 | 27 | 26      | 25 | 24 | 23 | 22 | 21 | 20 | 19 | 18 | 17 | 16 | 15            | 14                               | 13 | 12 | 11 | 10 | 9       | 8 | 7 | 6      | 5 | 4 | 3 | 2 | 1 | 0 |
|----------|--------|----|----|----|----|---------|----|----|----|----|----|----|----|----|----|----|---------------|----------------------------------|----|----|----|----|---------|---|---|--------|---|---|---|---|---|---|
| illop0   | Dest   |    |    |    |    | Source  |    |    |    |    | 0  | 0  | 0  | 0  | 0  | 0  | 0             | Unsigned Immediate               |    |    |    |    |         |   |   |        |   |   |   |   |   |   |
| trap     | -      | -  | -  | -  | E  | -       | -  | -  | -  | -  | 0  | 0  | 0  | 0  | 0  | 0  | 1             | Unsigned Trap Number             |    |    |    |    |         |   |   |        |   |   |   |   |   |   |
| cmdnd    | -      | -  | -  | -  | -  | -       | -  | -  | -  | -  | 0  | 0  | 0  | 0  | 0  | 1  | 0             | Unsigned Immediate               |    |    |    |    |         |   |   |        |   |   |   |   |   |   |
| rdcr     | Dest   |    |    |    |    | -       | -  | -  | -  | -  | 0  | 0  | 0  | 0  | 1  | 0  | 0             | Unsigned Control Register Number |    |    |    |    |         |   |   |        |   |   |   |   |   |   |
| swcr     | Dest   |    |    |    |    | Source  |    |    |    |    | 0  | 0  | 0  | 0  | 1  | 0  | 1             | Unsigned Control Register Number |    |    |    |    |         |   |   |        |   |   |   |   |   |   |
| brcr     | -      | -  | -  | -  | -  | -       | -  | -  | -  | -  | 0  | 0  | 0  | 0  | 1  | 1  | 0             | Unsigned Control Register Number |    |    |    |    |         |   |   |        |   |   |   |   |   |   |
| shift.dz | Dest   |    |    |    |    | Source  |    |    |    |    | 0  | 0  | 0  | 1  | 0  | 0  | 0             | -                                | -  | -  | i  | n  | Endmask |   |   | Rotate |   |   |   |   |   |   |
| shift.dm | Dest   |    |    |    |    | Source  |    |    |    |    | 0  | 0  | 0  | 1  | 0  | 0  | 1             | -                                | -  | -  | i  | n  | Endmask |   |   | Rotate |   |   |   |   |   |   |
| shift.ds | Dest   |    |    |    |    | Source  |    |    |    |    | 0  | 0  | 0  | 1  | 0  | 1  | 0             | -                                | -  | -  | i  | n  | Endmask |   |   | Rotate |   |   |   |   |   |   |
| shift.ez | Dest   |    |    |    |    | Source  |    |    |    |    | 0  | 0  | 0  | 1  | 0  | 1  | 1             | -                                | -  | -  | i  | n  | Endmask |   |   | Rotate |   |   |   |   |   |   |
| shift.em | Dest   |    |    |    |    | Source  |    |    |    |    | 0  | 0  | 0  | 1  | 1  | 0  | 0             | -                                | -  | -  | i  | n  | Endmask |   |   | Rotate |   |   |   |   |   |   |
| shift.es | Dest   |    |    |    |    | Source  |    |    |    |    | 0  | 0  | 0  | 1  | 1  | 0  | 1             | -                                | -  | -  | i  | n  | Endmask |   |   | Rotate |   |   |   |   |   |   |
| shift.iz | Dest   |    |    |    |    | Source  |    |    |    |    | 0  | 0  | 0  | 1  | 1  | 1  | 0             | -                                | -  | -  | i  | n  | Endmask |   |   | Rotate |   |   |   |   |   |   |
| shift.im | Dest   |    |    |    |    | Source  |    |    |    |    | 0  | 0  | 0  | 1  | 1  | 1  | 1             | -                                | -  | -  | i  | n  | Endmask |   |   | Rotate |   |   |   |   |   |   |
| and.tt   | Dest   |    |    |    |    | Source2 |    |    |    |    | 0  | 0  | 1  | 0  | 0  | 0  | 1             | Unsigned Immediate               |    |    |    |    |         |   |   |        |   |   |   |   |   |   |
| and.tf   | Dest   |    |    |    |    | Source2 |    |    |    |    | 0  | 0  | 1  | 0  | 0  | 1  | 0             | Unsigned Immediate               |    |    |    |    |         |   |   |        |   |   |   |   |   |   |
| and.ft   | Dest   |    |    |    |    | Source2 |    |    |    |    | 0  | 0  | 1  | 0  | 1  | 0  | 0             | Unsigned Immediate               |    |    |    |    |         |   |   |        |   |   |   |   |   |   |
| xor      | Dest   |    |    |    |    | Source2 |    |    |    |    | 0  | 0  | 1  | 0  | 1  | 1  | 0             | Unsigned Immediate               |    |    |    |    |         |   |   |        |   |   |   |   |   |   |
| or.tt    | Dest   |    |    |    |    | Source2 |    |    |    |    | 0  | 0  | 1  | 0  | 1  | 1  | 1             | Unsigned Immediate               |    |    |    |    |         |   |   |        |   |   |   |   |   |   |
| and.ff   | Dest   |    |    |    |    | Source2 |    |    |    |    | 0  | 0  | 1  | 1  | 0  | 0  | 0             | Unsigned Immediate               |    |    |    |    |         |   |   |        |   |   |   |   |   |   |
| xnor     | Dest   |    |    |    |    | Source2 |    |    |    |    | 0  | 0  | 1  | 1  | 0  | 0  | 1             | Unsigned Immediate               |    |    |    |    |         |   |   |        |   |   |   |   |   |   |
| or.tf    | Dest   |    |    |    |    | Source2 |    |    |    |    | 0  | 0  | 1  | 1  | 0  | 1  | 1             | Unsigned Immediate               |    |    |    |    |         |   |   |        |   |   |   |   |   |   |
| or.ft    | Dest   |    |    |    |    | Source2 |    |    |    |    | 0  | 0  | 1  | 1  | 1  | 0  | 1             | Unsigned Immediate               |    |    |    |    |         |   |   |        |   |   |   |   |   |   |
| or.ff    | Dest   |    |    |    |    | Source2 |    |    |    |    | 0  | 0  | 1  | 1  | 1  | 1  | 0             | Unsigned Immediate               |    |    |    |    |         |   |   |        |   |   |   |   |   |   |
| ld       | Dest   |    |    |    |    | Base    |    |    |    |    | 0  | 1  | 0  | 0  | M  | SZ | Signed Offset |                                  |    |    |    |    |         |   |   |        |   |   |   |   |   |   |
| ld.u     | Dest   |    |    |    |    | Base    |    |    |    |    | 0  | 1  | 0  | 1  | M  | SZ | Signed Offset |                                  |    |    |    |    |         |   |   |        |   |   |   |   |   |   |
| st       | Source |    |    |    |    | Base    |    |    |    |    | 0  | 1  | 1  | 0  | M  | SZ | Signed Offset |                                  |    |    |    |    |         |   |   |        |   |   |   |   |   |   |
| dcache   | -      | -  | -  | -  | F  | Source2 |    |    |    |    | 0  | 1  | 1  | 1  | M  | 0  | 0             | Signed Offset                    |    |    |    |    |         |   |   |        |   |   |   |   |   |   |
| bsr      | Link   |    |    |    |    | -       | -  | -  | -  | -  | 1  | 0  | 0  | 0  | 0  | 0  | A             | Signed Offset                    |    |    |    |    |         |   |   |        |   |   |   |   |   |   |
| jsr      | Link   |    |    |    |    | Base    |    |    |    |    | 1  | 0  | 0  | 0  | 1  | 0  | A             | Signed Offset                    |    |    |    |    |         |   |   |        |   |   |   |   |   |   |
| bbz      | BITNUM |    |    |    |    | Source  |    |    |    |    | 1  | 0  | 0  | 1  | 0  | 0  | A             | Signed Offset                    |    |    |    |    |         |   |   |        |   |   |   |   |   |   |
| bbo      | BITNUM |    |    |    |    | Source  |    |    |    |    | 1  | 0  | 0  | 1  | 0  | 1  | A             | Signed Offset                    |    |    |    |    |         |   |   |        |   |   |   |   |   |   |
| bcnd     | Cond   |    |    |    |    | Source  |    |    |    |    | 1  | 0  | 0  | 1  | 1  | 0  | A             | Signed Offset                    |    |    |    |    |         |   |   |        |   |   |   |   |   |   |
| cmp      | Dest   |    |    |    |    | Source2 |    |    |    |    | 1  | 0  | 1  | 0  | 0  | 0  | 0             | Signed Immediate                 |    |    |    |    |         |   |   |        |   |   |   |   |   |   |
| add      | Dest   |    |    |    |    | Source2 |    |    |    |    | 1  | 0  | 1  | 1  | 0  | 0  | U             | Signed Immediate                 |    |    |    |    |         |   |   |        |   |   |   |   |   |   |
| sub      | Dest   |    |    |    |    | Source2 |    |    |    |    | 1  | 0  | 1  | 1  | 0  | 1  | U             | Signed Immediate                 |    |    |    |    |         |   |   |        |   |   |   |   |   |   |

- Reserved bit (code as 0)
- A Annul delay slot instruction if branch taken
- E Emulation trap bit
- F Clear present flags
- i Invert endmask
- M Modify, write modified address back to register
- n Rotate sense for shifting
- SZ Size (0 = byte, 1 = halfword, 2 = word, 3 = doubleword)
- U Unsigned form



**MP opcode summary (continued)**

**Table 5. Long-Immediate and Three-Register Opcodes**

|          | 31 | 30 | 29 | 28 | 27 | 26 | 25 | 24 | 23 | 22 | 21 | 20 | 19 | 18 | 17 | 16 | 15 | 14 | 13 | 12 | 11 | 10 | 9 | 8 | 7 | 6 | 5 | 4 | 3 | 2 | 1 | 0       |         |
|----------|----|----|----|----|----|----|----|----|----|----|----|----|----|----|----|----|----|----|----|----|----|----|---|---|---|---|---|---|---|---|---|---------|---------|
| trap     | –  | –  | –  | –  | E  | –  | –  | –  | –  | –  | 1  | 1  | 0  | 0  | 0  | 0  | 0  | 0  | 0  | 1  | I  | –  | – | – | – | – | – | – | – | – | – | –       | IND TR  |
| cmnd     | –  | –  | –  | –  | –  | –  | –  | –  | –  | –  | 1  | 1  | 0  | 0  | 0  | 0  | 0  | 0  | 1  | 0  | I  | –  | – | – | – | – | – | – | – | – | – | –       | Source1 |
| rdcr     |    |    |    |    |    |    |    |    |    |    | 1  | 1  | 0  | 0  | 0  | 0  | 1  | 0  | 0  | I  | –  | –  | – | – | – | – | – | – | – | – | – | IND CR  |         |
| swcr     |    |    |    |    |    |    |    |    |    |    | 1  | 1  | 0  | 0  | 0  | 0  | 1  | 0  | 1  | I  | –  | –  | – | – | – | – | – | – | – | – | – | IND CR  |         |
| brcr     | –  | –  | –  | –  | –  | –  | –  | –  | –  | –  | 1  | 1  | 0  | 0  | 0  | 0  | 1  | 1  | 0  | I  | –  | –  | – | – | – | – | – | – | – | – | – | –       | IND CR  |
| shift.dz |    |    |    |    |    |    |    |    |    |    | 1  | 1  | 0  | 0  | 0  | 1  | 0  | 0  | 0  | 0  | I  | i  | n |   |   |   |   |   |   |   |   | Endmask | Rotate  |
| shift.dm |    |    |    |    |    |    |    |    |    |    | 1  | 1  | 0  | 0  | 0  | 1  | 0  | 0  | 1  | 0  | I  | i  | n |   |   |   |   |   |   |   |   | Endmask | Rotate  |
| shift.ds |    |    |    |    |    |    |    |    |    |    | 1  | 1  | 0  | 0  | 0  | 1  | 0  | 1  | 0  | 0  | I  | i  | n |   |   |   |   |   |   |   |   | Endmask | Rotate  |
| shift.ez |    |    |    |    |    |    |    |    |    |    | 1  | 1  | 0  | 0  | 0  | 1  | 0  | 1  | 1  | 0  | I  | i  | n |   |   |   |   |   |   |   |   | Endmask | Rotate  |
| shift.em |    |    |    |    |    |    |    |    |    |    | 1  | 1  | 0  | 0  | 0  | 1  | 1  | 0  | 0  | 0  | I  | i  | n |   |   |   |   |   |   |   |   | Endmask | Rotate  |
| shift.es |    |    |    |    |    |    |    |    |    |    | 1  | 1  | 0  | 0  | 0  | 1  | 1  | 0  | 1  | 0  | I  | i  | n |   |   |   |   |   |   |   |   | Endmask | Rotate  |
| shift.iz |    |    |    |    |    |    |    |    |    |    | 1  | 1  | 0  | 0  | 0  | 1  | 1  | 1  | 0  | 0  | I  | i  | n |   |   |   |   |   |   |   |   | Endmask | Rotate  |
| shift.im |    |    |    |    |    |    |    |    |    |    | 1  | 1  | 0  | 0  | 0  | 1  | 1  | 1  | 1  | 0  | I  | i  | n |   |   |   |   |   |   |   |   | Endmask | Rotate  |
| and.tt   |    |    |    |    |    |    |    |    |    |    | 1  | 1  | 0  | 0  | 1  | 0  | 0  | 0  | 1  | I  | –  | –  | – | – | – | – | – | – | – | – | – | –       | Source1 |
| and.tf   |    |    |    |    |    |    |    |    |    |    | 1  | 1  | 0  | 0  | 1  | 0  | 0  | 1  | 0  | I  | –  | –  | – | – | – | – | – | – | – | – | – | –       | Source1 |
| and.ft   |    |    |    |    |    |    |    |    |    |    | 1  | 1  | 0  | 0  | 1  | 0  | 1  | 0  | 0  | I  | –  | –  | – | – | – | – | – | – | – | – | – | –       | Source1 |
| xor      |    |    |    |    |    |    |    |    |    |    | 1  | 1  | 0  | 0  | 1  | 0  | 1  | 1  | 0  | I  | –  | –  | – | – | – | – | – | – | – | – | – | –       | Source1 |
| or.tt    |    |    |    |    |    |    |    |    |    |    | 1  | 1  | 0  | 0  | 1  | 0  | 1  | 1  | 1  | I  | –  | –  | – | – | – | – | – | – | – | – | – | –       | Source1 |
| and.ff   |    |    |    |    |    |    |    |    |    |    | 1  | 1  | 0  | 0  | 1  | 1  | 0  | 0  | 0  | I  | –  | –  | – | – | – | – | – | – | – | – | – | –       | Source1 |
| xnor     |    |    |    |    |    |    |    |    |    |    | 1  | 1  | 0  | 0  | 1  | 1  | 0  | 0  | 1  | I  | –  | –  | – | – | – | – | – | – | – | – | – | –       | Source1 |
| or.tf    |    |    |    |    |    |    |    |    |    |    | 1  | 1  | 0  | 0  | 1  | 1  | 0  | 1  | 1  | I  | –  | –  | – | – | – | – | – | – | – | – | – | –       | Source1 |
| or.ft    |    |    |    |    |    |    |    |    |    |    | 1  | 1  | 0  | 0  | 1  | 1  | 1  | 0  | 1  | I  | –  | –  | – | – | – | – | – | – | – | – | – | –       | Source1 |
| or.ff    |    |    |    |    |    |    |    |    |    |    | 1  | 1  | 0  | 0  | 1  | 1  | 1  | 1  | 0  | I  | –  | –  | – | – | – | – | – | – | – | – | – | –       | Source1 |
| ld       |    |    |    |    |    |    |    |    |    |    | 1  | 1  | 0  | 1  | 0  | 0  |    |    | M  | SZ | I  | S  | D | – | – | – | – | – | – | – | – | Offset  |         |
| ld.u     |    |    |    |    |    |    |    |    |    |    | 1  | 1  | 0  | 1  | 0  | 1  |    |    | M  | SZ | I  | S  | D | – | – | – | – | – | – | – | – | Offset  |         |
| st       |    |    |    |    |    |    |    |    |    |    | 1  | 1  | 0  | 1  | 1  | 0  |    |    | M  | SZ | I  | S  | D | – | – | – | – | – | – | – | – | Offset  |         |
| dcache   | –  | –  | –  | –  | F  |    |    |    |    |    | 1  | 1  | 0  | 1  | 1  | 1  |    |    | M  | 0  | 0  | I  | 0 | 0 | – | – | – | – | – | – | – | Source1 |         |
| bsr      |    |    |    |    |    |    |    |    |    |    | 1  | 1  | 1  | 0  | 0  | 0  | 0  | 0  |    | A  | I  | –  | – | – | – | – | – | – | – | – | – | –       | Offset  |
| jsr      |    |    |    |    |    |    |    |    |    |    | 1  | 1  | 1  | 0  | 0  | 0  | 1  | 0  |    | A  | I  | –  | – | – | – | – | – | – | – | – | – | –       | Offset  |
| bbz      |    |    |    |    |    |    |    |    |    |    | 1  | 1  | 1  | 0  | 0  | 1  | 0  | 0  |    | A  | I  | –  | – | – | – | – | – | – | – | – | – | –       | Target  |
| bbo      |    |    |    |    |    |    |    |    |    |    | 1  | 1  | 1  | 0  | 0  | 1  | 0  | 1  |    | A  | I  | –  | – | – | – | – | – | – | – | – | – | –       | Target  |
| bcnd     |    |    |    |    |    |    |    |    |    |    | 1  | 1  | 1  | 0  | 0  | 1  | 1  | 0  |    | A  | I  | –  | – | – | – | – | – | – | – | – | – | –       | Target  |
| cmp      |    |    |    |    |    |    |    |    |    |    | 1  | 1  | 1  | 0  | 1  | 0  | 0  | 0  | 0  | I  | –  | –  | – | – | – | – | – | – | – | – | – | –       | Source1 |
| add      |    |    |    |    |    |    |    |    |    |    | 1  | 1  | 1  | 0  | 1  | 1  | 0  | 0  |    | U  | I  | –  | – | – | – | – | – | – | – | – | – | –       | Source1 |
| sub      |    |    |    |    |    |    |    |    |    |    | 1  | 1  | 1  | 0  | 1  | 1  | 0  | 1  |    | U  | I  | –  | – | – | – | – | – | – | – | – | – | –       | Source1 |

- |   |   |
|---|---|
| <ul style="list-style-type: none"> <li>– Reserved bit (code as 0)</li> <li>D Direct external access bit</li> <li>E Emulation trap bit</li> <li>F Clear present flags</li> <li>i Invert endmask</li> </ul> | <ul style="list-style-type: none"> <li>I Long immediate</li> <li>M Modify, write modified address back to register</li> <li>n Rotate sense for shifting</li> <li>S Scale offset by data size</li> <li>SZ Size (0 = byte, 1 = halfword, 2 = word, 3 = doubleword)</li> </ul> |
|---|---|

# TMS320C80 DIGITAL SIGNAL PROCESSOR

SPRS023B – JULY 1994 – REVISED OCTOBER 1997

## MP opcode summary (continued)

**Table 6. Miscellaneous Instruction Opcodes**

|           | 31          | 30 | 29 | 28 | 27 | 26          | 25 | 24 | 23 | 22 | 21 | 20 | 19 | 18 | 17 | 16 | 15 | 14 | 13 | 12 | 11 | 10 | 9  | 8  | 7 | 6  | 5 | 4 | 3       | 2       | 1       | 0 |
|-----------|-------------|----|----|----|----|-------------|----|----|----|----|----|----|----|----|----|----|----|----|----|----|----|----|----|----|---|----|---|---|---------|---------|---------|---|
| vadd      | Mem Src/Dst |    |    |    |    | Source2/Dst |    |    |    |    | 1  | 1  | 1  | 1  | 0  | -  | 0  | 0  | 0  | 0  | l  | -  | m  | P  | - | d  | m | s |         |         | Source1 |   |
| vsub      | Mem Src/Dst |    |    |    |    | Source2/Dst |    |    |    |    | 1  | 1  | 1  | 1  | 0  | -  | 0  | 0  | 1  | l  | -  | m  | P  | -  | d | m  | s |   |         | Source1 |         |   |
| vmpy      | Mem Src/Dst |    |    |    |    | Source2/Dst |    |    |    |    | 1  | 1  | 1  | 1  | 0  | -  | 0  | 1  | 0  | l  | -  | m  | P  | -  | d | m  | s |   |         | Source1 |         |   |
| vmsub     | Mem Src/Dst |    |    |    |    | Dest        |    |    |    |    | 1  | 1  | 1  | 1  | 0  | a  | 0  | 1  | 1  | l  | a  | m  | P  | Z  | - | m  | - |   |         | Source1 |         |   |
| vrnd(FP)  | Mem Src/Dst |    |    |    |    | Dest        |    |    |    |    | 1  | 1  | 1  | 1  | 0  | a  | 1  | 0  | 0  | l  | a  | m  | P  | PD |   | m  | s |   |         | Source1 |         |   |
| vrnd(Int) | Mem Src/Dst |    |    |    |    | Dest        |    |    |    |    | 1  | 1  | 1  | 1  | 0  | -  | 1  | 0  | 1  | l  | -  | m  | P  | -  | d | m  | s |   |         | Source1 |         |   |
| vmac      | Mem Src/Dst |    |    |    |    | Source2     |    |    |    |    | 1  | 1  | 1  | 1  | 0  | a  | 1  | 1  | 0  | l  | a  | m  | P  | Z  | - | m  | - |   |         | Source1 |         |   |
| vmsc      | Mem Src/Dst |    |    |    |    | Source2     |    |    |    |    | 1  | 1  | 1  | 1  | 0  | a  | 1  | 1  | 1  | l  | a  | m  | P  | Z  | - | m  | - |   |         | Source1 |         |   |
| fadd      | Dest        |    |    |    |    | Source2     |    |    |    |    | 1  | 1  | 1  | 1  | 1  | 0  | 0  | 0  | 0  | l  | -  |    | PD | P2 |   | P1 |   |   | Source1 |         |         |   |
| fsub      | Dest        |    |    |    |    | Source2     |    |    |    |    | 1  | 1  | 1  | 1  | 1  | 0  | 0  | 0  | 1  | l  | -  |    | PD | P2 |   | P1 |   |   | Source1 |         |         |   |
| fmpy      | Dest        |    |    |    |    | Source2     |    |    |    |    | 1  | 1  | 1  | 1  | 1  | 0  | 0  | 1  | 0  | l  | -  |    | PD | P2 |   | P1 |   |   | Source1 |         |         |   |
| fdiv      | Dest        |    |    |    |    | Source2     |    |    |    |    | 1  | 1  | 1  | 1  | 1  | 0  | 0  | 1  | 1  | l  | -  |    | PD | P2 |   | P1 |   |   | Source1 |         |         |   |
| frndx     | Dest        |    | -  | -  | -  | -           |    |    |    |    | 1  | 1  | 1  | 1  | 1  | 0  | 1  | 0  | 0  | l  | -  |    | PD | RM |   | P1 |   |   | Source1 |         |         |   |
| fcmp      | Dest        |    |    |    |    | Source2     |    |    |    |    | 1  | 1  | 1  | 1  | 1  | 0  | 1  | 0  | 1  | l  | -  | -  | -  | P2 |   | P1 |   |   | Source1 |         |         |   |
| fsqrt     | Dest        |    | -  | -  | -  | -           |    |    |    |    | 1  | 1  | 1  | 1  | 1  | 0  | 1  | 1  | 1  | l  | -  |    | PD | -  | - | P1 |   |   | Source1 |         |         |   |
| lmo       | Dest        |    |    |    |    | Source      |    |    |    |    | 1  | 1  | 1  | 1  | 1  | 1  | 0  | 0  | 0  | -  |    | -  | -  | -  | - | -  | - | - | -       | -       | -       |   |
| rmo       | Dest        |    |    |    |    | Source      |    |    |    |    | 1  | 1  | 1  | 1  | 1  | 1  | 0  | 0  | 1  | -  |    | -  | -  | -  | - | -  | - | - | -       | -       | -       |   |
| estop     | -           | -  | -  | -  | -  | -           |    |    |    |    | 1  | 1  | 1  | 1  | 1  | 1  | 1  | 1  | 0  | -  |    | -  | -  | -  | - | -  | - | - | -       | -       | -       |   |
| illopF    | -           | -  | -  | -  | -  | -           |    |    |    |    | 1  | 1  | 1  | 1  | 1  | 1  | 1  | 1  | 1  | C  |    | -  | -  | -  | - | -  | - | - | -       | -       | -       |   |

- Reserved bit (code as 0)
- a Floating-point accumulator select
- C Constant operands rather than register
- d Destination precision for vector (0 = sp, 1 = dp)
- l Long immediate 32-bit data
- m Parallel memory operation specifier
- Mem Src/Dst Vector store or load source/dst register
- Dest Destination register
- P Dest precision for parallel load/store (0 = single, 1 = double)
- P1 Precision of source1 operand
- P2 Precision of source2 operand
- PD Precision of destination result
- RM Rounding Mode (0 = N, 1 = Z, 2 = P, 3 = M)
- s Scale offset by data size
- Z Use 0 rather than accumulator



**MP opcode summary (continued)**

**Table 7. Summary of MP Opcodes**

| INSTRUCTION | DESCRIPTION                    | INSTRUCTION | DESCRIPTION  |
|-------------|--------------------------------|-------------|--|
| add         | Signed integer add             | or.ff       | Bitwise OR with 1s complement                                |
| and.tt      | Bitwise AND                    | or.ft       | Bitwise OR with 1s complement                                |
| and.ff      | Bitwise AND with 1s complement | or.tf       | Bitwise OR with 1s complement                                |
| and.ft      | Bitwise AND with 1s complement | rdcr        | Read control register  |
| and.tf      | Bitwise AND with 1s complement | rmo         | Rightmost one  |
| bbo         | Branch bit one                 | shift.dz    | Shift, disable mask, zero extend                             |
| bbz         | Branch bit zero                | shift.dm    | Shift, disable mask, merge                                   |
| bcnd        | Branch conditional             | shift.ds    | Shift, disable mask, sign extend                             |
| br          | Branch always                  | shift.ez    | Shift, enable mask, zero extend                              |
| brcr        | Branch control register        | shift.em    | Shift, enable mask, merge                                    |
| bsr         | Branch and save return         | shift.es    | Shift, enable mask, sign extend                              |
| cmnd        | Send command                   | shift.iz    | Shift, invert mask, zero extend                              |
| cmp         | Integer compare                | shift.im    | Shift, invert mask, merge                                    |
| dcache      | Flush data cache sub-block     | st          | Store register into memory                                   |
| estop       | Emulation stop                 | sub         | Signed integer subtract                                      |
| fadd        | Floating-point add             | swcr        | Swap control register  |
| fcmp        | Floating-point compare         | trap        | Trap   |
| fdiv        | Floating-point divide          | vadd        | Vector floating-point add                                    |
| fmpy        | Floating-point multiply        | vmac        | Vector floating-point multiply and add to accumulator        |
| frndx       | Floating-point convert/round   | vmpy        | Vector floating-point multiply                               |
| fsqrt       | Floating-point square root     | vmsc        | Vector floating-point multiply and subtract from accumulator |
| fsub        | Floating-point subtract        | vmsub       | Vector floating-point subtract accumulator from source       |
| ilop        | Illegal operation              | vrnd(FP)    | Vector round with floating-point input                       |
| jsr         | Jump and save return           | vrnd(Int)   | Vector round with integer input                              |
| ld          | Load signed into register      | vsub        | Vector floating-point subtract                               |
| ld.u        | Load unsigned into register    | xnor        | Bitwise exclusive NOR  |
| lmo         | Leftmost one                   | xor         | Bitwise exclusive OR   |
| or.tt       | Bitwise OR                     |             |  |

### PP architecture

The parallel processor (PP) is a 32-bit integer DSP optimized for imaging and graphics applications. Each PP can execute in parallel; a multiply, ALU operation, and two memory accesses within a single instruction. This internal parallelism allows a single PP to achieve over 500 million operations per second for certain algorithms. The PP has a three-input ALU that supports all 256 three input Boolean combinations and many combinations of arithmetic and Boolean functions. Data-merging and bit-to-byte, bit-to-word, and bit-to-halfword translations are supported by hardware in the input data path to the ALU. Typical tasks performed by a PP include:

- Pixel-intensive processing
  - Motion estimation
  - Convolution
  - PixBLTs
  - Warp
  - Histogram
  - Mean square error
- Domain transforms
  - DCT
  - FFT
  - Hough
- Core graphics functions
  - Line
  - Circle
  - Shaded fills
  - Fonts
- Image Analysis
  - Segmentation
  - Feature extraction
- Bit-stream encoding/decoding
  - Data merging
  - Table look-ups

---

### PP functional block diagram

Figure 22 shows a block diagram of a parallel processor. Key features of the PP include:

- 64-bit instruction word (supports multiple parallel operations)
- Three-stage pipeline for fast instruction cycle
- Numerous registers
  - 8 data, 10 address, 6 index registers
  - 20 other user-visible registers
- Data Unit
  - 16x16 integer multiplier (optional dual 8x8)
  - Splittable 3-input ALU
  - 32-bit barrel rotator
  - Mask generator
  - Multiple-status flag expander for translations to/from 1 bit-per-pixel space.
  - Conditional assignment of data unit results
  - Conditional source selection
  - Special processing hardware
    - Leftmost one / rightmost one
    - Leftmost bit change / rightmost bit change
- Memory addressing
  - Two address units (global & local) provide up to two 32-bit accesses in parallel with data unit operation.
  - 12 addressing modes (immediate and indexed)
  - Byte, halfword, and word addressability
  - Scaled indexed addressing
  - Conditional assignment for loads
  - Conditional source selection for stores
- Program flow
  - Three hardware loop controllers
    - Zero overhead looping / branching
    - Nested loops
    - Multiple loop endpoints
  - Instruction cache management
  - PC mapped to register file
  - Interrupts for messages and context switching
- Algebraic assembly language

# TMS320C80 DIGITAL SIGNAL PROCESSOR

SPRS023B – JULY 1994 – REVISED OCTOBER 1997

## PP functional block diagram (continued)

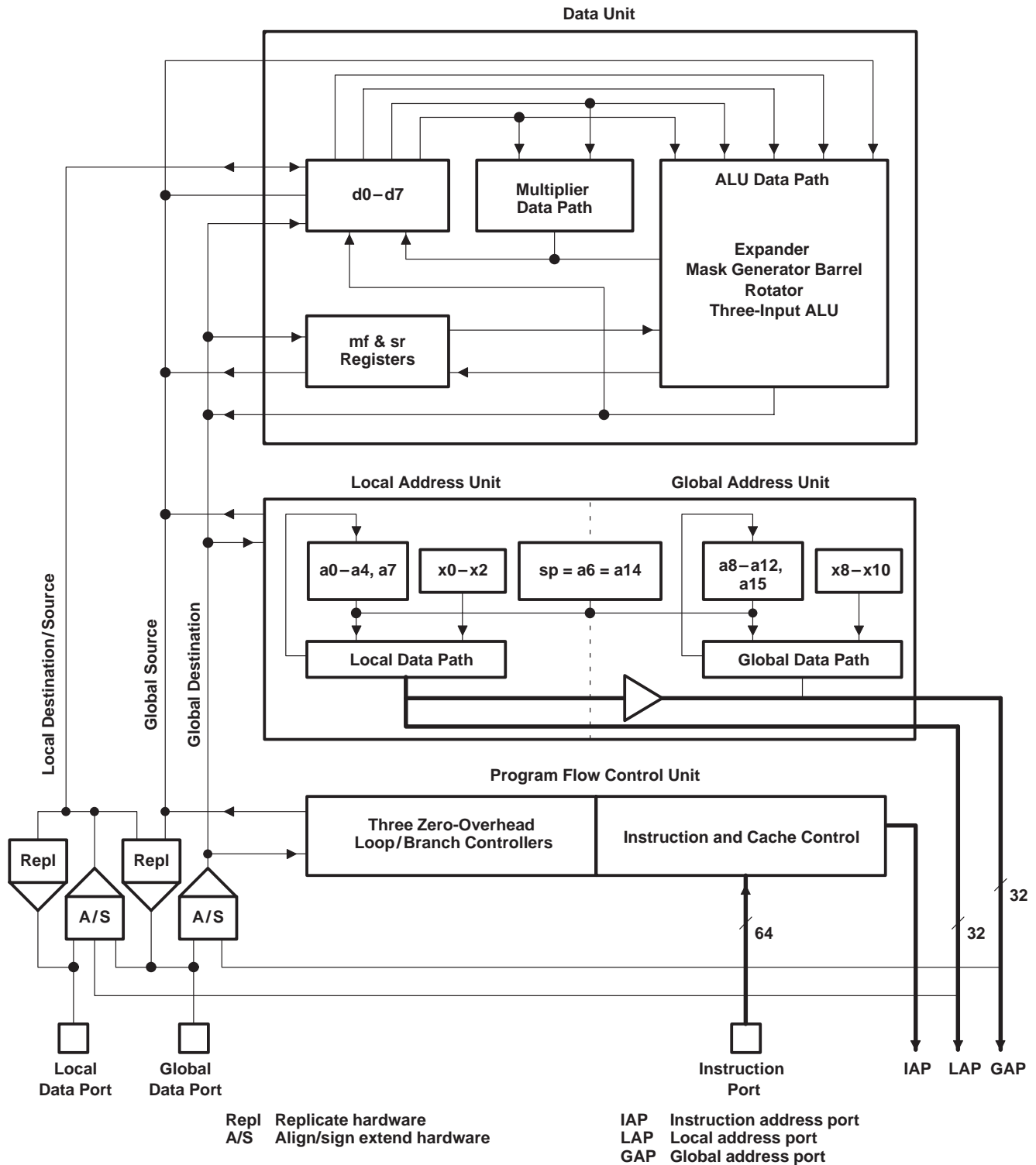
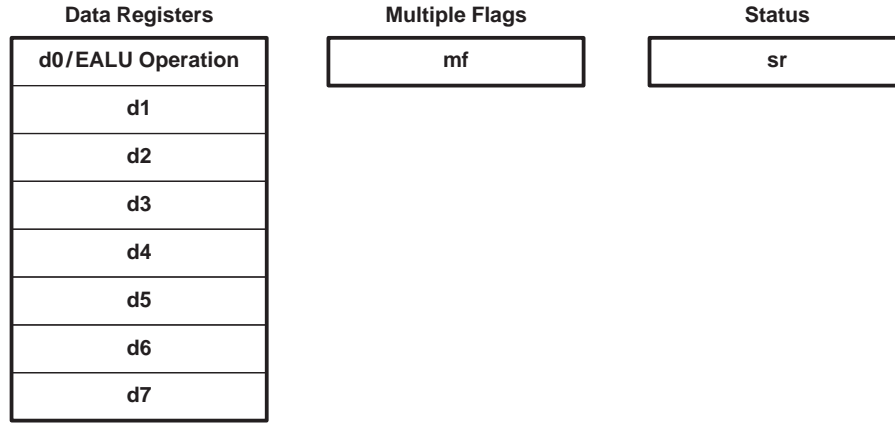

Figure 22. PP Block Diagram

## PP registers

The PP contains many general-purpose registers, status registers, and configuration registers. All PP registers are 32-bit registers. Figure 23 shows the accessible registers of the PP blocks.

### Data-Unit Registers



### Address-Unit Registers

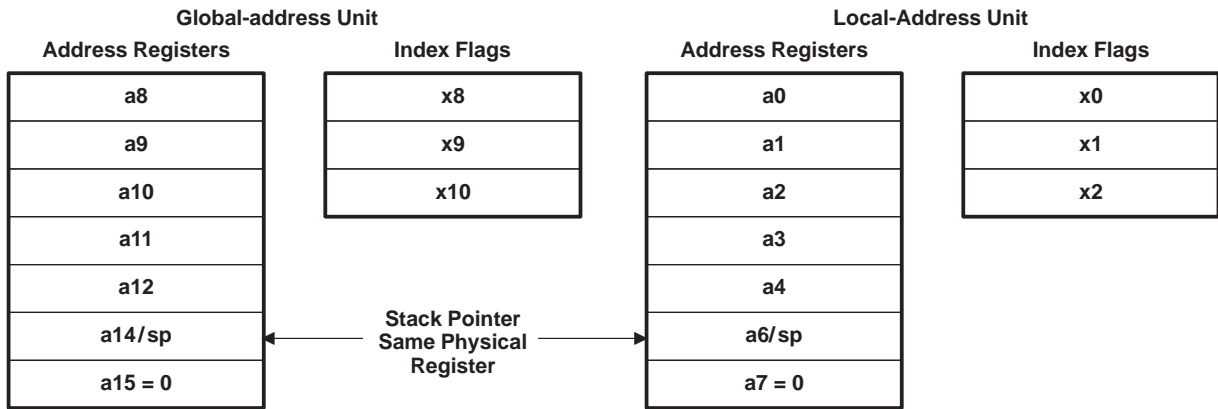

### PFC-Unit Registers

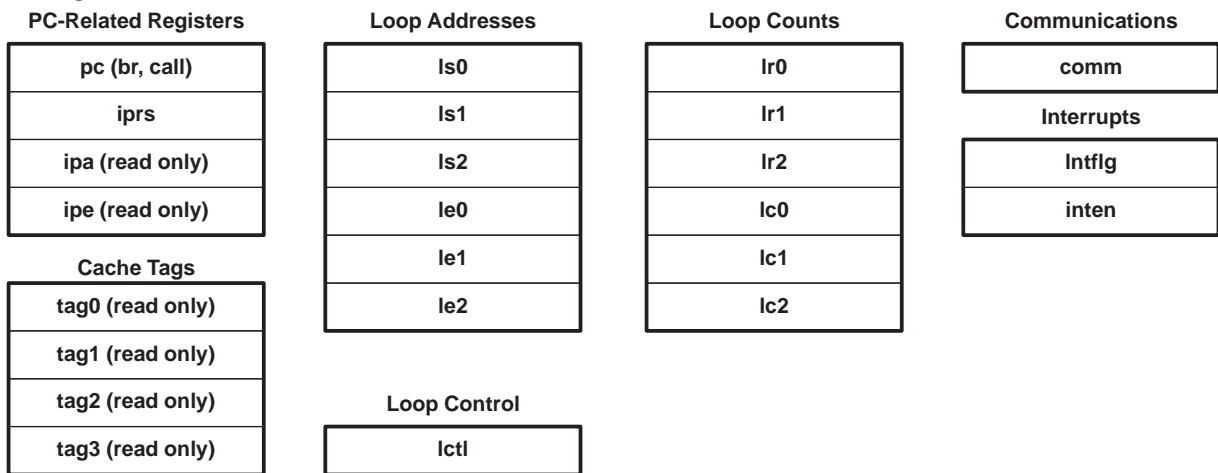

Figure 23. PP Registers

# TMS320C80 DIGITAL SIGNAL PROCESSOR

SPRS023B – JULY 1994 – REVISED OCTOBER 1997

## PP data-unit registers

The data unit contains eight 32-bit general-purpose data registers (d0–d7) referred to as the D registers. The d0 register also acts as the control register for EALU operations.

### d0 register

Figure 24 shows the format when d0 is used as the EALU control register.

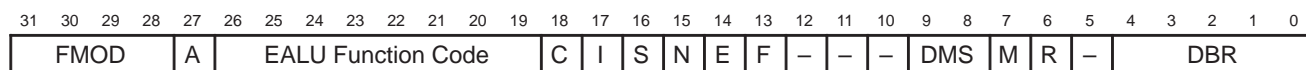

- |      |                    |     |                               |
|------|--------------------|-----|-------------------------------|
| FMOD | Function modifiers | E   | Explicit multiple carry-In    |
| A    | Arithmetic enable  | F   | Expanded mf                   |
| C    | EALU carry-In      | DMS | Default multiply shift amount |
| I    | Invert-carry-In    | M   | Split multiply                |
| S    | Sign extend        | R   | Rounded multiply              |
| N    | Nonmultiple mask   | DBR | Default barrel rotate amount  |

**Figure 24. d0 Format for EALU Operations**

### multiple flags (mf) register

The mf register records status information from each split ALU segment for multiple arithmetic operations. The mf register may be expanded to generate a mask for the ALU. Figure 25 shows the mf register format.

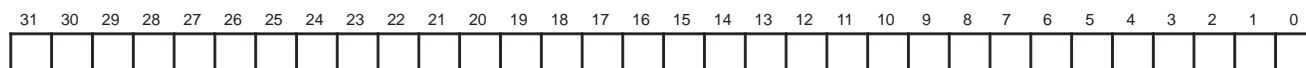

**Figure 25. mf Register Format**

### status register (sr)

The sr contains status and control bits for the PP ALU. Figure 26 shows the sr register format.

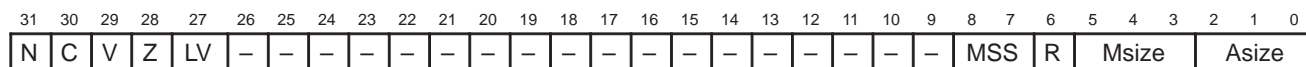

- |    |                     |       |  |
|----|---------------------|-------|--|
| N  | Negative status bit | MSS   | mf Status selection                          |
| C  | Carry status bit    | 00    | – set by zero    10 – set by extended result |
| V  | Overflow status bit | 01    | – set by sign    11 – reserved               |
| Z  | Zero status bit     | Msize | Expander data size                           |
| LV | Latched overflow    | Asize | Split ALU data size                          |
| R  | Rotation bit        |       |  |

**Figure 26. sr Format**

## PP address-unit registers

### address registers

The address unit contains ten 32-bit address registers which contain the base address for address computations or which can be used for general-purpose data. The registers a0 – a4 are used for local address computations and registers a8–a12 are used for global-address computations.



## index registers

The six 32-bit index registers contain index values for use with the address registers in address computations or they can be used for general-purpose data. Registers x0–x2 are used by the local-address unit and registers x8–x10 are used by the global-address unit.

## stack pointer (sp)

The sp contains the address of the bottom of the PP's system stack. The stack pointer is addressed as a6 by the local-address unit and as a14 by the global-address unit. Figure 27 shows the sp register format.

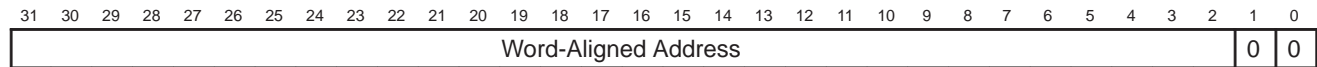

Figure 27. sp Register Format

## zero register

The zero registers are read-as-zero address registers for the local address unit (a7) and global-address unit (a15). Writes to the registers are ignored and can be specified when operational results are to be discarded. Figure 28 shows the zero register format.

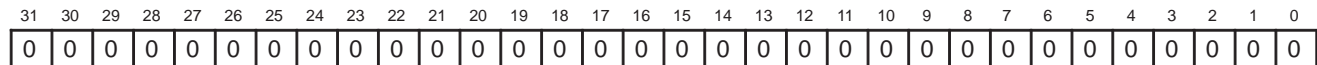

Figure 28. zero Registers

## PP program flow control (PFC) unit registers

### loop registers

The loop registers control three levels of zero-overhead loops. The 32-bit loop start registers (ls0 – ls2) and loop-end registers (le0 – le2) contain the starting and ending addresses for the loops. The loop-counter registers (lc0 – lc2) contain the number of repetitions remaining in their associated loops. The lr0 – lr2 registers are loop reload registers used to support nested loops. The format for the loop-control (lctl) register is shown in Figure 29. There are also six special write-only mappings of the loop-reload registers. The lrs0 – lrs2 codes are used for fast initialization of lsn, lrn, and lcn registers for multi-instruction loops while the lrse0 – lrse2 codes are used for single instruction-loop fast initialization.

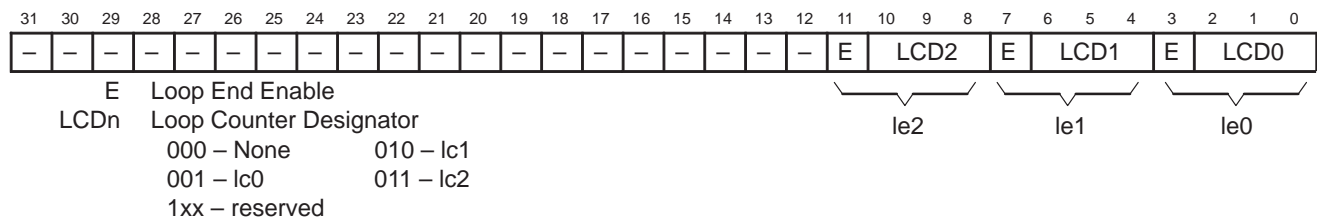

Figure 29. lctl Register

### pipeline registers

The PFC unit contains a pointer to each stage of the PP pipeline. The pc contains the program counter which points to the instruction being fetched. The ipa points to the instruction in the address stage of the pipeline and the ipe points to the instruction in the execute stage of the pipeline. The instruction pointer return-from-subroutine (iprs) register contains the return address for a subroutine call. Figure 30 shows the variable pipeline register format.

# TMS320C80 DIGITAL SIGNAL PROCESSOR

SPRS023B – JULY 1994 – REVISED OCTOBER 1997

## pipeline registers (continued)

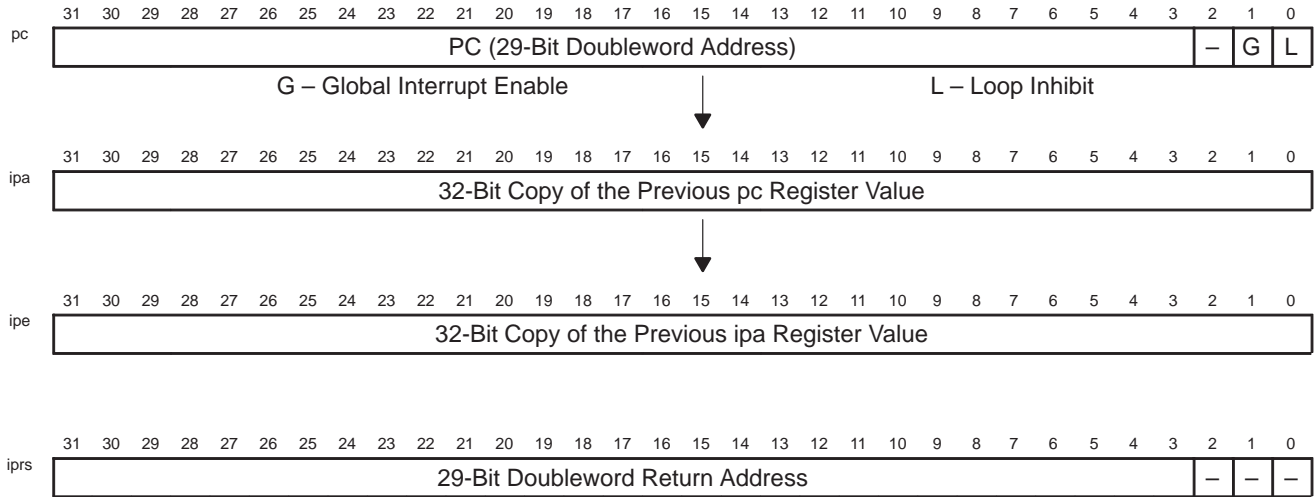

**Figure 30. Pipeline Registers**

## interrupt registers

The interrupt-enable (inten) register allows individual interrupts to be enabled and configures the interrupt flag (intflg) register operation. The intflg register contains the interrupt flag bits. Interrupt priority increases moving from left to right on intflg. Figure 31 shows the PP-interrupt register format.

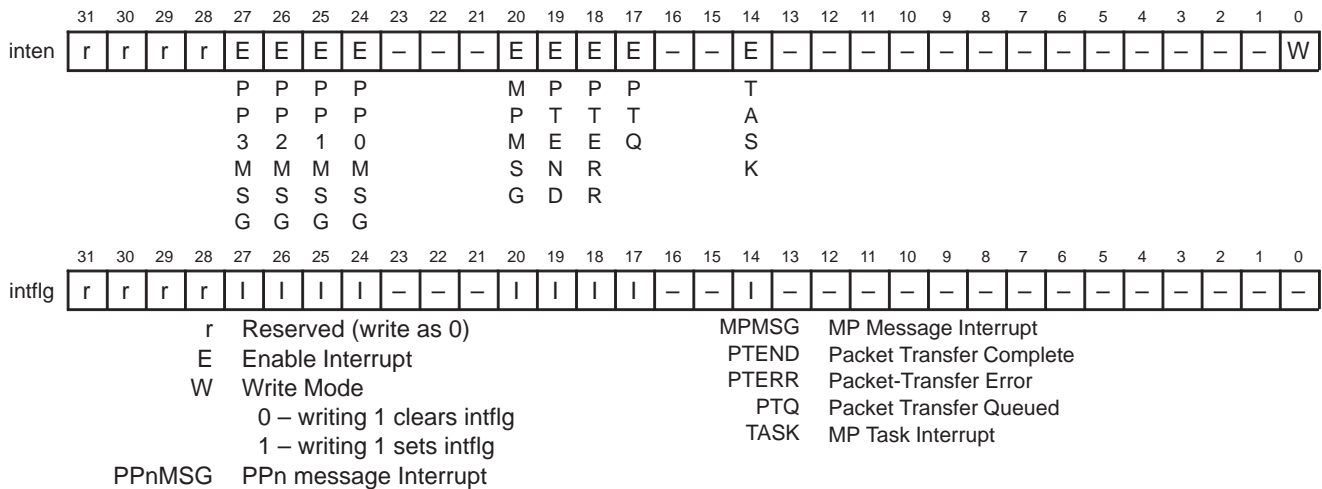

**Figure 31. PP-Interrupt Registers**

**communication (comm) register**

The comm register contains the packet-transfer handshake bits and PP indicator bits. Figure 32 shows the comm register format.

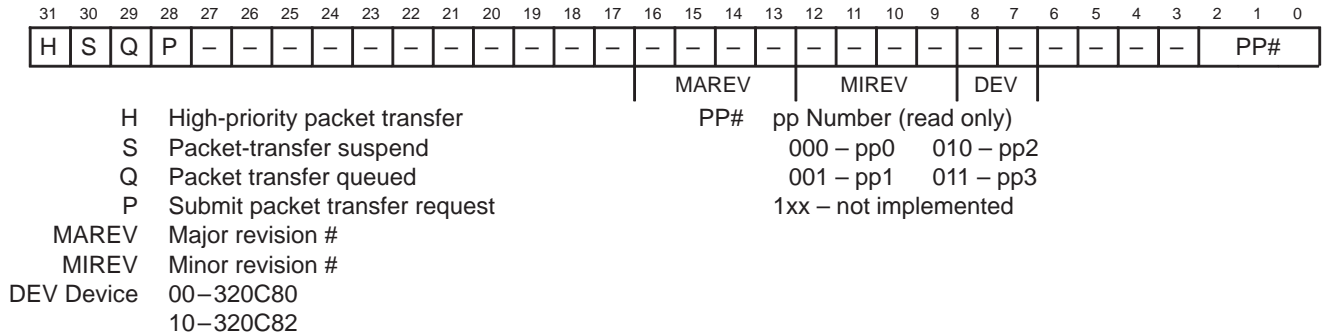

**Figure 32. comm Register**

**cache-tag registers**

The tag0 – tag3 registers contain the tag address and sub-block present bits for each cache block. Figure 33 shows the cache tag registers.

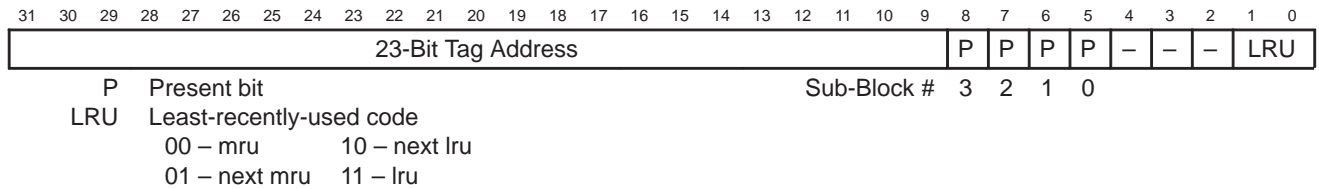

**Figure 33. Cache Tag Registers**

**PP cache architecture**

Each PP has its own 2K-byte instruction cache. Each cache is divided into four blocks and each block is divided into four sub-blocks containing 16 64-bit instructions each. Cache misses cause one sub-block to be loaded into cache. Figure 34 shows the cache architecture for one of the four sets in each cache. Figure 35 shows how addresses map into the cache using the cache tags and address bits.

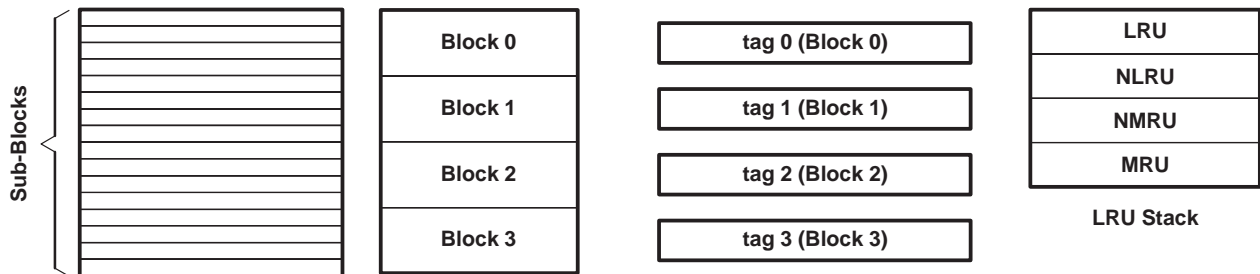

**Figure 34. PP Cache Architecture**

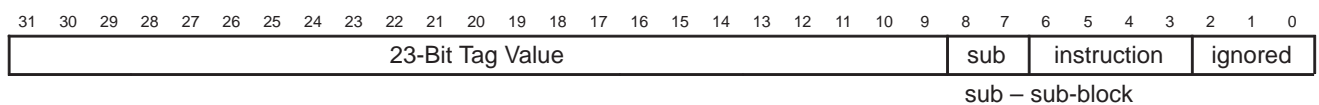

**Figure 35. pc Register Cache-Address Mapping**

**PP parameter RAM**

The parameter RAM is a, 2K-byte, on-chip RAM which contains PP-interrupt vectors, PP-requested TC task buffers, and a general-purpose area. The parameter RAM does not use the cache memory. Figure 36 shows the parameter RAM address map.

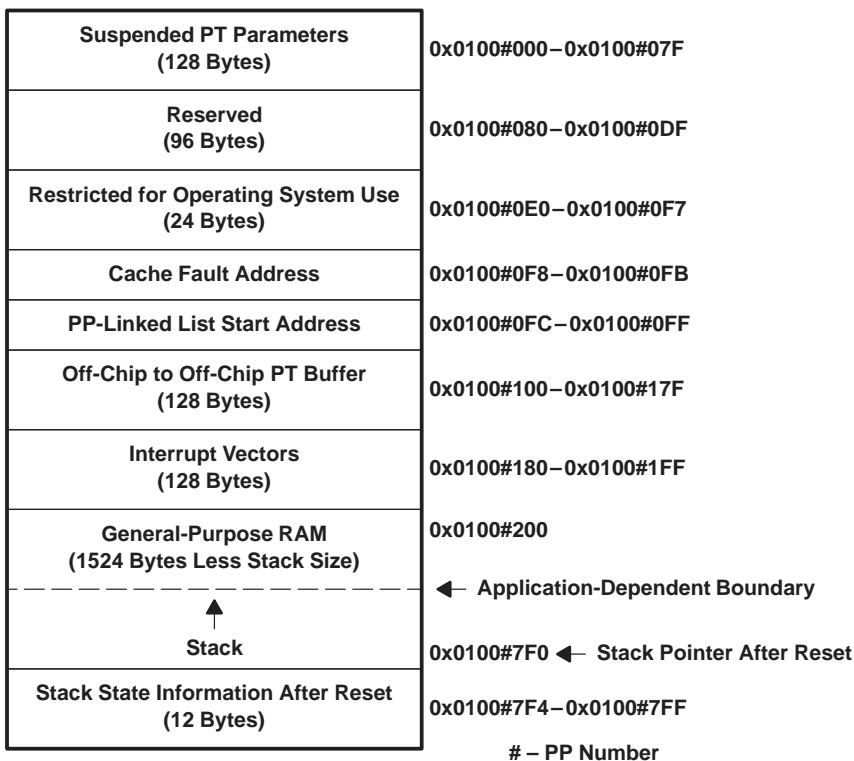

**Figure 36. PP Parameter RAM**

**PP interrupt vectors**

The PP interrupts and their vector addresses are shown in Table 8.

**Table 8. PP-Interrupt Vectors**

| NAME   | VECTOR ADDRESS | INTERRUPT              |
|--------|----------------|------------------------|
| TASK   | 0x0100#1B8     | Task Interrupt         |
| PTQ    | 0x0100#1C4     | Packet Transfer Queued |
| PTERR  | 0x0100#1C8     | Packet-Transfer Error  |
| PTEND  | 0x0100#1CC     | Packet-Transfer End    |
| MPMSG  | 0x0100#1D0     | MP Message             |
| PP0MSG | 0x0100#1E0     | PP0 Message            |
| PP1MSG | 0x0100#1E4     | PP1 Message            |
| PP2MSG | 0x0100#1E8     | PP2 Message            |
| PP3MSG | 0x0100#1EC     | PP3 Message            |

### PP data-unit architecture

The data unit has independent data paths for the ALU and the multiplier, each with its own set of hardware functions. The multiplier data path includes a 16 × 16 multiplier, a halfword swapper, and rounding hardware. The ALU data path includes a 32-bit three-input ALU, a barrel rotator, mask generator, mf expander, left/rightmost one and left/rightmost bit-change logic, and several multiplexers. Figure 37 shows the data-unit block diagram.

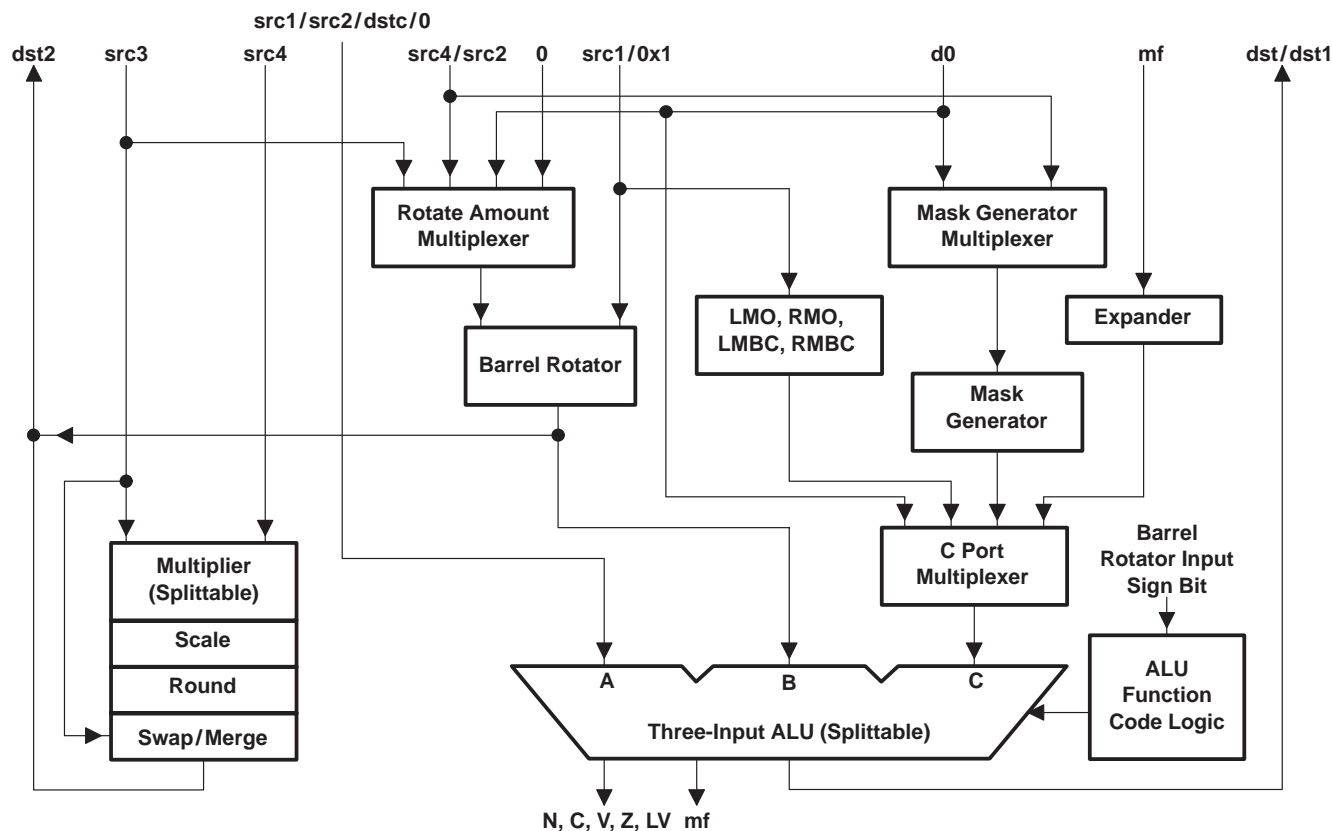

Legend:

|          |   |      |   |
|----------|---|------|---|
| src1     | Any register, D reg only for l/rmo, l/rmbc hardware | dst2 | D reg only                                    |
| scr2     | D reg or sometimes 15/32-bit immediate              | dstc | D reg only (destination companion reg source) |
| scr3     | D reg only  | 0x1  | Constant                                      |
| scr4     | D reg only  | 0    | Constant                                      |
| dst/dst1 | Any register  | d0   | 5 LSBs of d0                                  |

Figure 37. Data Unit Block Diagram

The PP's ALU can be split into one 32-bit ALU, two 16-bit ALUs, or four 8-bit ALUs. Figure 38 shows the multiple arithmetic data flow for the case of a four 8-bit split of the ALU (called multiple-byte arithmetic). The ALU operates as independent parallel ALUs where each ALU receives the same function code.

PP data-unit architecture (continued)

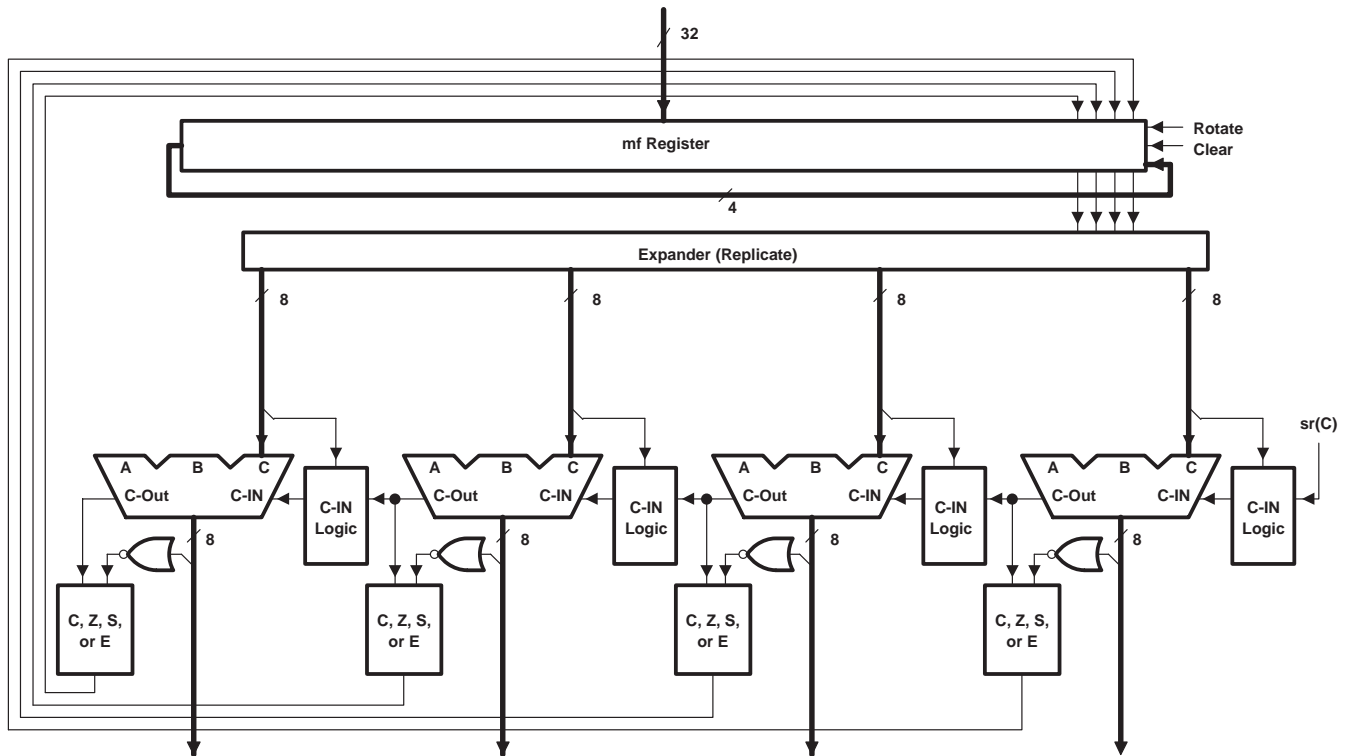

Figure 38. Multiple-Byte Arithmetic Data Flow

PP multiplier

The PP's hardware multiplier can perform one 16x16 multiply with a 32-bit result or two 8x8 multiplies with two 16-bit results in a single cycle. A 16x16 multiply can use signed or unsigned operands as shown in Figure 39.



Figure 39. 16 x 16 Multiplier Data Formats

When performing two simultaneous 8x8 split multiplies, the first input word contains unsigned byte operands and the second input word contains signed or unsigned byte operands. These formats are shown in Figure 40 and Figure 41.

**PP multiplier (continued)**

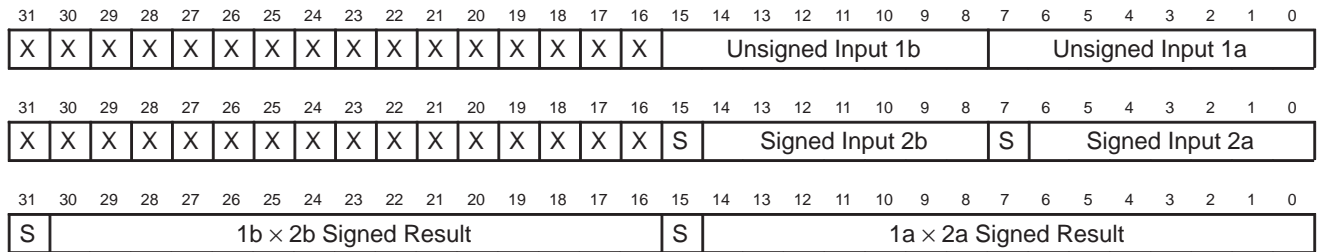

**Figure 40. Signed Split Multiply Data Formats**

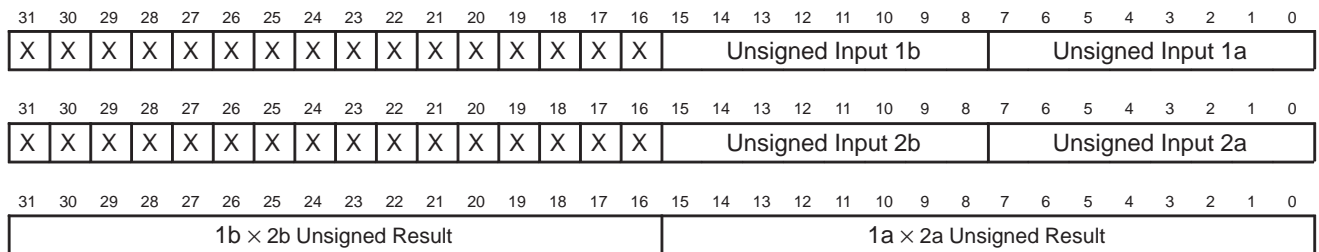
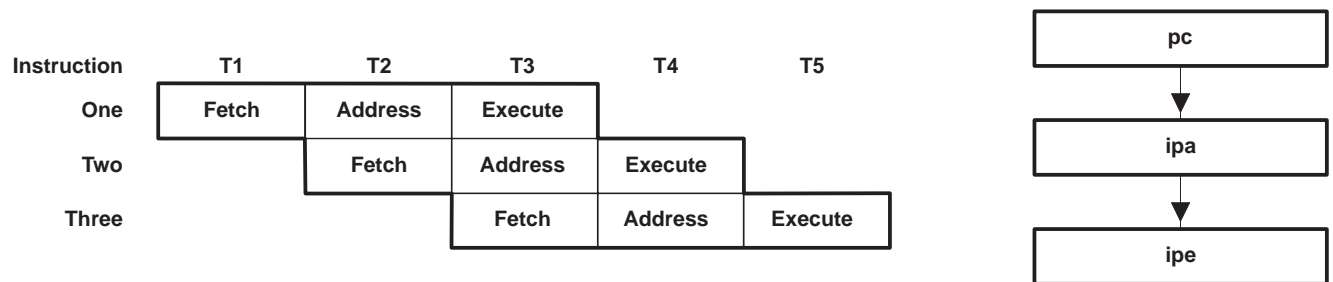

**Figure 41. Unsigned Split Multiply Data Formats**

**PP program-flow-control unit architecture**

The PP has a three-stage fetch, address, execute (FAE) pipeline as shown in Figure 42. The pc, ipa, and ipe registers point to the address of the instruction in each stage of the pipeline. On each cycle in which the pipeline advances, ipa is copied into ipe, pc is copied into ipa, and the pc is incremented by one instruction (8 bytes).

The program-flow-control (pfc) unit performs instruction fetching and decoding, loop control, and handshaking with the transfer controller. The pfc unit architecture is shown in Figure 43.



**Figure 42. FAE-Instruction Pipeline**

PP program-flow-control unit architecture (continued)

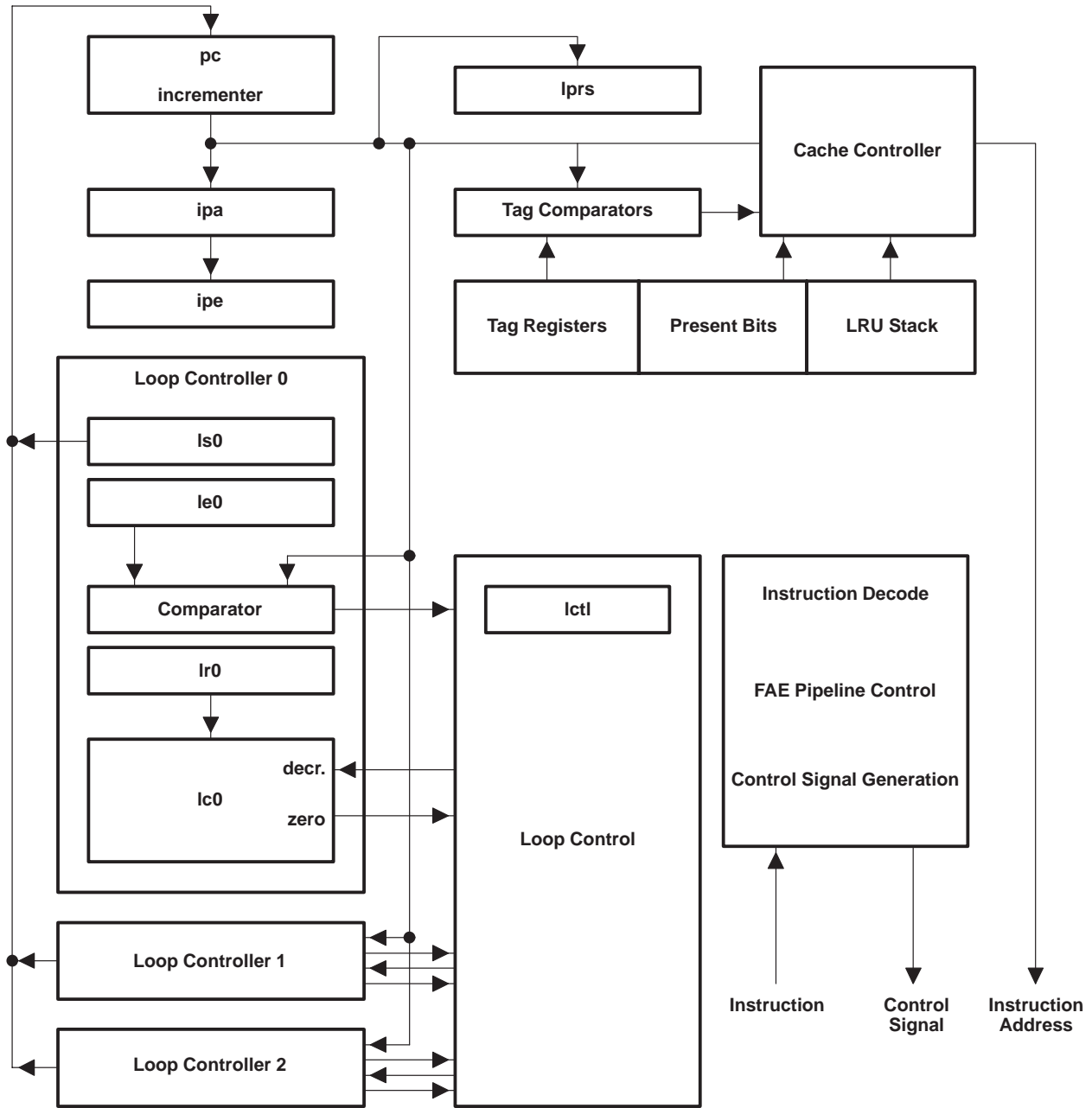

Figure 43. Program-Flow-Control Unit Block Diagram

PP address-unit architecture

The PP has both a local- and global-address unit which operate independently of each other. The address units support twelve different addressing modes. In place of performing a memory access, either or both of the address units can perform an address computation that is written directly to a PP register instead of being used for a memory access. This address-unit arithmetic provides additional arithmetic operation to supplement the data unit during compute-intensive algorithms. Figure 44 shows the address-out architecture.

PP address-unit architecture (continued)

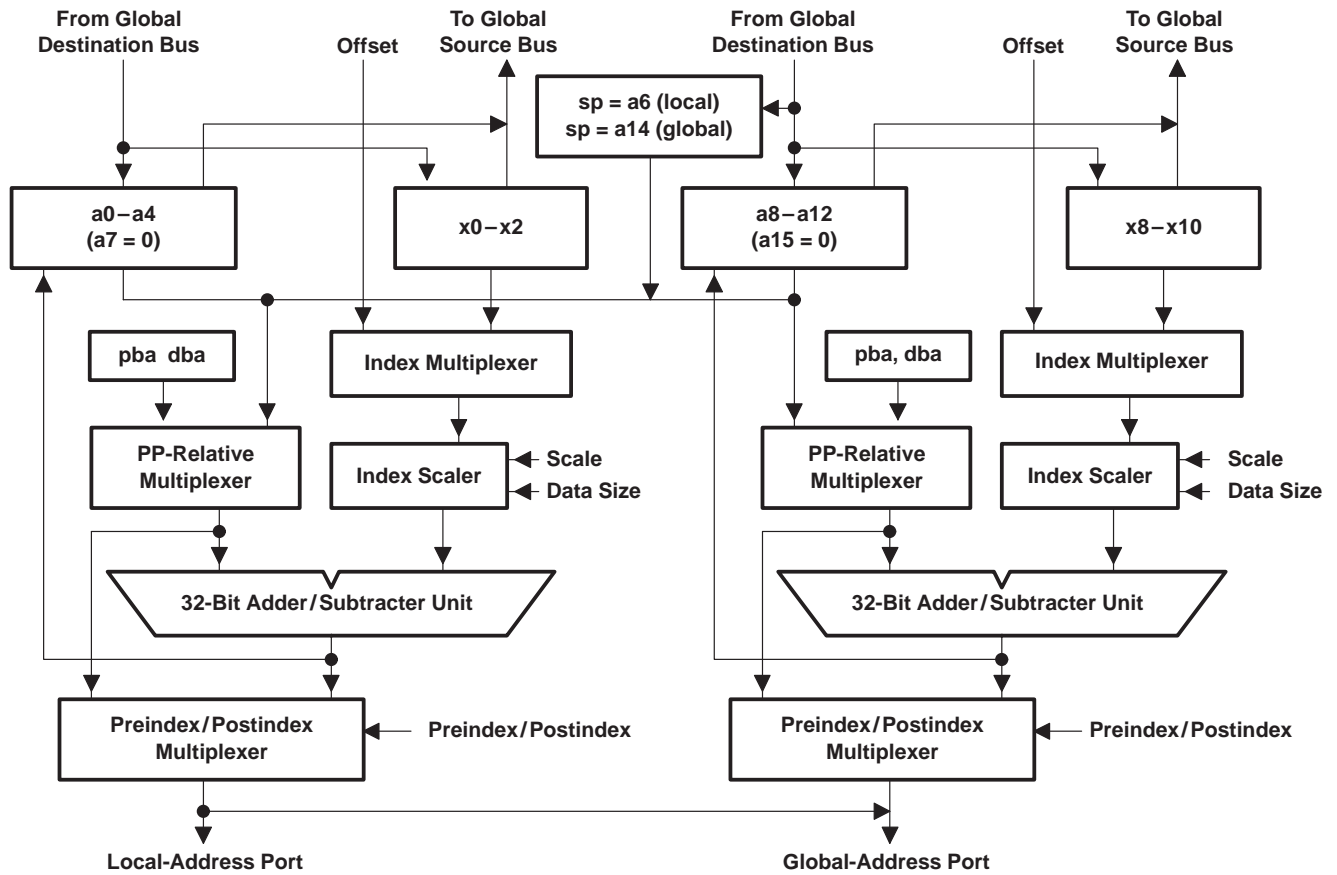

Figure 44. Address-Unit Architecture

PP instruction set

PP instructions are represented by algebraic expressions for the operations performed in parallel by the multiplier, ALU, global-address unit, and local-address unit. The expressions use the || symbol to indicate operations that are to be performed in parallel. The PP ALU operator syntax is shown in Table 9. The data unit operations (multiplier and ALU) are summarized in Table 10 and the parallel transfers (global and local) are summarized in Table 11.

**PP instruction set (continued)**

**Table 9. PP Operators by Precedence**

| <b>OPERATOR</b> | <b>FUNCTION</b>  |
|-----------------|--|
| src1 [n] src1-1 | Select odd (n=true) or even (n=false) register of D register pair based on negative condition code |
| ( )             | Subexpression delimiters   |
| @mf             | Expander operator  |
| %               | Mask generator   |
| %%              | Nonmultiple mask generator (EALU only)   |
| %!              | Modified mask generator (0xFFFFFFFF output for 0 input)  |
| %%!             | Nonmultiple shift right mask generator (EALU only)   |
| \               | Rotate left  |
| <<              | Shift left (pseudo-op for rotate and mask)   |
| >>u             | Unsigned shift right   |
| >> or >>s       | Signed shift right   |
| &               | Bitwise AND  |
| ^               | Bitwise XOR  |
|                 | Bitwise OR   |
| +               | Addition   |
| -               | Subtraction  |
| =[cond]         | Conditional assignment   |
| =[cond.pro]     | Conditional assignment with status protection  |
| =               | Equate   |

**PP instruction set (continued)**

**Table 10. Summary of Data-Unit Operations**

|             |  |
|-------------|--|
| Operation   | Base set ALUs  |
| Description | Perform an ALU operation specifying ALU function, 2 src and 1 dest operand, and operand routing. ALU function is one of 256 three-input Boolean operations or one of 17 arithmetic operations combined with one of 15 function modifiers.  |
| Syntax      | dst = [fmod] [ [cond [.pro]] ] ALU_EXPRESSION  |
| Examples    | d6 = (d6 ^ d4) & d2<br>d3 = [nn.nv] d1 -1  |
| Operation   | EALU    ROTATE   |
| Description | Perform an extended ALU (EALU) operation (specified in d0) with one of two data routings to the ALU and optionally write the barrel rotator output to a second dest register. ALU Function is one of 256 Boolean or 256 arithmetic.  |
| Syntax      | dst1 = [ [cond [.pro]] ] ealu (src2, [dst2 = [ [cond]] src1 [ [n]] src1-1] \ \ src3, [%] src4)<br>dst1 = [fmod] [ [cond [.pro]] ] ealu (label:EALU_EXPRESSION [    dst2 = [ [cond]] src1 [ [n]] src1-1] \ \ src3)  |
| Examples    | d7 = [nn] ealu(d2, d6 = [nn] d3\ \d1, %d4)<br>d3 = mzc ealu(mylabel: d4 + (d5\ \d6 & %d7)    d1 = d5\ \d6)   |
| Operation   | MPY    ADD   |
| Description | Perform a 16x16 multiply with optional parallel add or subtract. Condition code applies to both multiply and add.  |
| Syntax      | dst2 = [sign] [ [cond]] ] src3 * src4 [    dst = [ [cond[.pro]] ] src2 + src1 [ [n]] src1 -1] ]<br>dst2 = [sign] [ [cond]] ] src3 * src4 [    dst = [ [cond[.pro]] ] src2 - src1 [ [n]] src1 -1] ]   |
| Example     | d7 = u d6 * d5    d5 = d4 - d1   |
| Operation   | MPY    SADD  |
| Description | Perform a 16x16 multiply with a parallel right-shift and add or subtract. Condition code applies to multiply, shift, and add.  |
| Syntax      | dst2 = [sign] [ [cond]] ] src3 * src4    dst = [ [ cond [.pro]] ] src2 + src1 [ [n]] src1 -1] >> -d0<br>dst2 = [sign] [ [cond]] ] src3 * src4    dst = [ [ cond [.pro]] ] src2 - src1 [ [n]] src1 -1] >> -d0   |
| Examples    | d7 = u d6 * d5    d5 = d4 - d1 >> -d0  |
| Operation   | MPY    EALU  |
| Description | Perform a multiply and an optional parallel EALU. Multiply can use rounding, scaling, or splitting features.   |
| Syntax      | Generic Form:<br>dst2 = [sign] [ [cond]] ] src3 * src4    dst = [ [cond [.pro]] ] ealu[f] (src2, src1 [ [n]] src1 -1] \ \ d0, %d0)<br>dst2 = [sign] [ [cond]] ] src3 * src4    ealu()<br>Explicit Form:<br>dst2 = [sign] [opt] [ [cond]] ] src3 * src4 [<<dms]    dst1 = [fmod] [ [cond [.pro]] ] ealu (label: EALU_EXPRESSION)<br>dst2 = [sign] [opt] [ [cond]] ] src3 * src4 [<<dms]    ealu (label) |
| Examples    | d7 = [p] d5 * d3    d2 = [p] ealu(d1, d6\ \d0, %d0) ; generic form<br>d2 = m d4 * d7    d3 = ealu (mylabel: d3 + d2 >> 9) ; explicit form  |
| Operation   | divi   |
| Description | Perform one iteration of unsigned divide algorithm. Generates one quotient bit per execution using iterative subtraction.  |
| Syntax      | dst1 = [ [cond [.pro]] ] divi (src2, dst2 = [ [cond]] src1 [ [n]] src1 -1)   |
| Examples    | d3 = divi (d1, d2 = d2)<br>d3 = divi (d1, d2 = d3[n]d2)  |

Legend:

|       |                                      |      |                               |
|-------|--------------------------------------|------|-------------------------------|
| [ ]   | Optional parameter extension         | cond | Condition code                |
| [[ ]] | Square brackets ( [ ] ) must be used | fmod | Function modifier             |
| pro   | Protect status bits                  | dms  | Default multiply shift amount |
| f     | Use 1s compliment of d0              | sign | u = unsigned, s = signed      |

# TMS320C80 DIGITAL SIGNAL PROCESSOR

SPRS023B – JULY 1994 – REVISED OCTOBER 1997

---

## PP instruction set (continued)

**Table 10. Summary of Data-Unit Operations (Continued)**

|                  |  |
|------------------|--|
| Misc. Operations | dint; eint; nop; dloop; eloop; qwait   |
| Description      | Globally disable interrupts; globally enable interrupts; do nothing in the data unit; globally enable looping; globally disable looping; wait until comm register Q bit is zero. |
| Syntax           | dint dloop<br>eint eloop<br>nop qwait  |

Legend:

- |         |                                      |      |                               |
|---------|--------------------------------------|------|-------------------------------|
| [ ]     | Optional parameter extension         | cond | Condition code                |
| [ [ ] ] | Square brackets ( [ ] ) must be used | fmod | Function modifier             |
| pro     | Protect status bits                  | dms  | Default multiply shift amount |
| f       | Use 1s compliment of d0              | sign | u = unsigned, s = signed      |

PP instruction set (continued)

Table 11. Summary of Parallel Transfers

|             |  |
|-------------|--|
| Operation   | Load   |
| Description | Transfer from memory into PP register  |
| Syntax      | dst = [sign] [size] [ [[cond]] ] * addressp<br>dst = [sign] [size] [ [[cond]] ] * an.element |
| Examples    | d3 = uh[n] * (a9++=[2])<br>d1 = * a2.sMY_ELEMENT   |
| Operation   | Store  |
| Description | Transfer from PP register into memory  |
| Syntax      | * addressp = [size] src [ [[n]] src-1]<br>* an.element = [size] src [ [[n]] src-1]           |
| Examples    | *--a2 = d3<br>*a9.sMY_ELEMENT = a3   |
| Operation   | Address unit arithmetic  |
| Description | Compute address and store in PP register   |
| Syntax      | dst = [size] [ [[cond]] ] & * addressp<br>dst = [size] [ [[cond]] ] & * an.element           |
| Examples    | d2 = &*(a3 + x0)<br>a1 = &*a9.sMY_ELEMENT  |
| Operation   | Move   |
| Description | Transfer from PP register to PP register   |
| Syntax      | dst = [g] [ [[cond]] ] src   |
| Examples    | x2 = mf<br>d1 = g d3   |
| Operation   | Field extract move   |
| Description | Transfer from PP register to PP register extracting and right-aligning one byte or halfword  |
| Syntax      | dst = [sign] [size item]   |
| Example     | d3 = ub2 d1  |
| Operation   | Field replicate move   |
| Description | Transfer from PP register to PP register replicating the LSbyte or LShalfword to 32 bits     |
| Syntax      | dst = r [size] [[cond]] src  |
| Example     | d7 = rh d3   |

Legend:

|       |  |      |  |
|-------|--|------|--|
| [ ]   | Optional parameter extension                                   | cond | Condition code                             |
| [[ ]] | Square brackets ( [ ] ) must be used                           | sign | u = unsigned, s = signed                   |
| g     | Use global unit  | size | b = byte, h = halfword, w = word (default) |
| item  | 0 = byte0/halfword0, 1 = byte1/halfword1, 2 = byte2, 3 = byte3 |      |  |



**PP opcode formats (continued)**

**Table 12. Data Unit Mnemonics**

| MNEMONIC         | FUNCTION  |
|------------------|---|
| A                | A = 1 selects arithmetic operations, A = 0 selects Boolean operations   |
| ALU Operation    | For Boolean operation (A = 0) select the 8 ALU function signals. For arithmetic operation (A = 1), odd bits specify the ALU function and even bits define the ALU function modifiers. |
| class            | Operation class, determines routing of ALU operands   |
| cond             | condition code  |
| dst              | D register destination or lower 3 bits of non-D register code   |
| dst1             | ALU dest. for MPY  ADD, MPY  EALU, or EALU  ROTATE operation. D register or lower 3 bits of non-D register code   |
| dst2             | Multiply dest. for MPY  ADD or MPY  EALU operation or rotate dest. for EALU  ROTATE operation. D register   |
| dstbank          | ALU register bank   |
| imm.src2         | 5-bit immediate for src2 of ALU operation   |
| 32-Bit Immediate | 32-bit immediate for src2 of ALU operation  |
| oper             | Six-operand data unit operation (MPY  ADD, MPY  SADD, MPY  EALU, EALU  ROTATE, divi)  |
| Operation        | Miscellaneous operation   |
| src1             | ALU source 1 register code (D register unless srcbank or s1bank is used)  |
| src2             | D register used as ALU source 2   |
| src3             | D register for multiplier source (MPY  ADD or MPY  EALU) or rotate amount (EALU  ROTATE)  |
| src4             | D reg for ALU C port operand or EALU  ROTATE mask generator input or multiplier source 2 for MPY  ADD, MPY  EALU  |
| s1bnk            | Bits 5-3 of src1 register code (bit 6 assumed to be 0)  |

**PP opcode formats (continued)**

**Table 13. Parallel Transfer Mnemonics**

| <b>MNEMONIC</b> | <b>FUNCTION</b>   |
|-----------------|---|
| 0bank           | Bits 5–3 of global transfer source/destination register code (bit 6 assumed to be 0)                                      |
| Adstbnk         | Bits 6–3 of ALU destination register code   |
| As1bank         | Bits 6–3 of ALU source 1 register code  |
| bank            | Bits 6–3 of global (or local) store source or load destination  |
| c               | Conditional choice of D register for src1 operand of the ALU  |
| C               | Protect status register's carry bit   |
| cond            | Condition code  |
| d               | D register or lower 3 bits of register code for local transfer source/destination   |
| D               | Duplicate least significant data during moves   |
| dst             | The three lowest bits of the register code for move or field move destination   |
| dstbank         | Bits 6–3 of move destination register code  |
| e               | Sign extend local (bit 31), sign extend global (bit 9)  |
| g               | Conditional global transfer   |
| Ga              | Global address register for load, store, or address unit arithmetic   |
| Gim / X         | Global address unit immediate offset or index register  |
| Gmode           | Global unit addressing mode   |
| Grm             | Global PP-relative addressing mode  |
| itm             | Number of item selected for field extract move  |
| L               | L = 1 selects load operation, L = 0 selects store/address unit arithmetic operation                                       |
| La              | Local address register for load, store, or address unit arithmetic  |
| Lim / X         | Local address unit immediate offset or index register   |
| Lmode           | Local unit addressing mode  |
| Lrm             | Local PP-relative addressing mode   |
| N               | Protect status register's negative bit  |
| r               | Conditional write of ALU result   |
| reg             | Register number used with bank or 0bank for global load, store, or address unit arithmetic                                |
| s               | Enable index scaling. Additional index bit for byte accesses or arithmetic operations (bit 28, local; bit 6, global)      |
| size            | Size of data transfer (bits 30–29, local; bits 8–7, global)   |
| src             | Three lowest bits of register code for register-register move source or non-field moves. D register source for field move |
| srcbank         | Bits 6–3 of register code for register-register move source   |
| V               | Protect status register's overflow bit  |
| Z               | Protect status register's zero bit  |
| –               | Unused bit (fill with 0)  |

**PP opcode formats (continued)**

Table 14 summarizes the supported parallel-transfer formats, their formats, and whether the transfers are local or global. It also lists the allowed ALU operations and states whether conditions and status protection are supported.

**Table 14. Parallel-Transfer Format Summary**

| FORMAT                 | ALU OPERANDS |       | Cond | Status Protection | GLOBAL TRANSFER   |                |         |     | LOCAL TRANSFER |         |     |        |
|------------------------|--------------|-------|------|-------------------|-------------------|----------------|---------|-----|----------------|---------|-----|--------|
|                        | dst1         | src1  |      |                   | Move<br>src → dst | Load/Store/AUA |         |     | Load/Store/AUA |         |     |        |
|                        |              |       |      |                   |                   | s/d            | Index   | Rel | s/d            | Index   | Rel | Port   |
| Double parallel        | D            | D     | No   | No                | —                 | Lower          | X/short | No  | D              | X/short | No  | Local  |
| Move    Local          | D            | D     | No   | No                | Any→Any           | —              | —       | —   | D              | X/short | Yes | Local  |
| Field move    Local    | D            | D     | No   | No                | D→Any             | —              | —       | —   | D              | X/short | No  | Local  |
| Global (long offset)   | D            | D     | No   | No                | —                 | Any            | X/long  | Yes | —              | —       | —   | —      |
| Local (long offset)    | D            | D     | No   | No                | —                 | —              | —       | —   | Any            | X/long  | Yes | Global |
| Non-D DU    Local      | Any          | Any   | No   | No                | —                 | —              | —       | —   | D              | X/short | Yes | Global |
| Conditional move       | D            | D     | Yes  | Yes               | Any→Any           | —              | —       | —   | —              | —       | —   | —      |
| Conditional field move | D            | D     | Yes  | Yes               | D→Any             | —              | —       | —   | —              | —       | —   | —      |
| Conditional global     | D            | D     | Yes  | Yes               | —                 | Any            | X/short | Yes | —              | —       | —   | —      |
| Conditional non-D DU   | Any          | Any   | Yes  | Yes               | —                 | —              | —       | —   | —              | —       | —   | —      |
| 32-bit imm. base ALU   | Any          | Lower | Yes  | No                | —                 |                |         |     |                |         |     |        |

Legend:

- DU Data unit
- AUA Address unit arithmetic
- s/d Source/destination register
- Rel Relative addressing support

# TMS320C80 DIGITAL SIGNAL PROCESSOR

SPRS023B – JULY 1994 – REVISED OCTOBER 1997

## PP opcode formats (continued)

Table 15 shows the encoding used in the opcodes to specify particular PP registers. A 3-bit register field contains the three LSBs. The register codes are used for the src, src1, src2, src3, src4, dst, dst1, dst2, d, reg, Ga, La, Gim/X, and Lim/X opcode fields. The four MSBs specify the register bank which is concatenated to the register field for the full 7-bit code. The register bank codes are used for the dstbank, s1bnk, srcbank, 0bank, bank, Adstbnk, and As1bank opcode fields. When no associated bank is specified for a register field in the opcode, the D register bank is assumed. When the MSB of the bank code is not specified in the opcode (as in 0bank and s1bnk) it is assumed to be 0, indicating a lower register.

Table 15. PP Register Codes

| LOWER REGISTERS (MSB OF BANK = 0) |     |            |        |     |          | UPPER REGISTERS (MSB OF BANK = 1) |     |          |        |     |          |
|-----------------------------------|-----|------------|--------|-----|----------|-----------------------------------|-----|----------|--------|-----|----------|
| CODING                            |     | REGISTER   | CODING |     | REGISTER | CODING                            |     | REGISTER | CODING |     | REGISTER |
| BANK                              | REG |            | BANK   | REG |          | BANK                              | REG |          | BANK   | REG |          |
| 0000                              | 000 | a0         | 0100   | 000 | d0       | 1000                              | 000 | reserved | 1100   | 000 | lc0      |
| 0000                              | 001 | a1         | 0100   | 001 | d1       | 1000                              | 001 | reserved | 1100   | 001 | lc1      |
| 0000                              | 010 | a2         | 0100   | 010 | d2       | 1000                              | 010 | reserved | 1100   | 010 | lc2      |
| 0000                              | 011 | a3         | 0100   | 011 | d3       | 1000                              | 011 | reserved | 1100   | 011 | reserved |
| 0000                              | 100 | a4         | 0100   | 100 | d4       | 1000                              | 100 | reserved | 1100   | 100 | lr0      |
| 0000                              | 101 | reserved   | 0100   | 101 | d5       | 1000                              | 101 | reserved | 1100   | 101 | lr1      |
| 0000                              | 110 | a6 (sp)    | 0100   | 110 | d6       | 1000                              | 110 | reserved | 1100   | 110 | lr2      |
| 0000                              | 111 | a7 (zero)  | 0100   | 111 | d7       | 1000                              | 111 | reserved | 1100   | 111 | reserved |
| 0001                              | 000 | a8         | 0101   | 000 | reserved | 1001                              | 000 | reserved | 1101   | 000 | lrse0    |
| 0001                              | 001 | a9         | 0101   | 001 | sr       | 1001                              | 001 | reserved | 1101   | 001 | lrse1    |
| 0001                              | 010 | a10        | 0101   | 010 | mf       | 1001                              | 010 | reserved | 1101   | 010 | lrse2    |
| 0001                              | 011 | a11        | 0101   | 011 | reserved | 1001                              | 011 | reserved | 1101   | 011 | reserved |
| 0001                              | 100 | a12        | 0101   | 100 | reserved | 1001                              | 100 | reserved | 1101   | 100 | lrs0     |
| 0001                              | 101 | reserved   | 0101   | 101 | reserved | 1001                              | 101 | reserved | 1101   | 101 | lrs1     |
| 0001                              | 110 | a14 (sp)   | 0101   | 110 | reserved | 1001                              | 110 | reserved | 1101   | 110 | lrs2     |
| 0001                              | 111 | a15 (zero) | 0101   | 111 | reserved | 1001                              | 111 | reserved | 1101   | 111 | reserved |
| 0010                              | 000 | x0         | 0110   | 000 | reserved | 1010                              | 000 | reserved | 1110   | 000 | ls0      |
| 0010                              | 001 | x1         | 0110   | 001 | reserved | 1010                              | 001 | reserved | 1110   | 001 | ls1      |
| 0010                              | 010 | x2         | 0110   | 010 | reserved | 1010                              | 010 | reserved | 1110   | 010 | ls2      |
| 0010                              | 011 | reserved   | 0110   | 011 | reserved | 1010                              | 011 | reserved | 1110   | 011 | reserved |
| 0010                              | 100 | reserved   | 0110   | 100 | reserved | 1010                              | 100 | reserved | 1110   | 100 | le0      |
| 0010                              | 101 | reserved   | 0110   | 101 | reserved | 1010                              | 101 | reserved | 1110   | 101 | le1      |
| 0010                              | 110 | reserved   | 0110   | 110 | reserved | 1010                              | 110 | reserved | 1110   | 110 | le2      |
| 0010                              | 111 | reserved   | 0110   | 111 | reserved | 1010                              | 111 | reserved | 1110   | 111 | reserved |
| 0011                              | 000 | x8         | 0111   | 000 | pc/call  | 1011                              | 000 | reserved | 1111   | 000 | reserved |
| 0011                              | 001 | x9         | 0111   | 001 | ipa/br   | 1011                              | 001 | reserved | 1111   | 001 | reserved |
| 0011                              | 010 | x10        | 0111   | 010 | ipe #    | 1011                              | 010 | reserved | 1111   | 010 | reserved |
| 0011                              | 011 | reserved   | 0111   | 011 | iprs     | 1011                              | 011 | reserved | 1111   | 011 | reserved |
| 0011                              | 100 | reserved   | 0111   | 100 | inten    | 1011                              | 100 | reserved | 1111   | 100 | tag0 #   |
| 0011                              | 101 | reserved   | 0111   | 101 | intflg   | 1011                              | 101 | reserved | 1111   | 101 | tag1 #   |
| 0011                              | 110 | reserved   | 0111   | 110 | comm     | 1011                              | 110 | reserved | 1111   | 110 | tag2 #   |
| 0011                              | 111 | reserved   | 0111   | 111 | lctl     | 1011                              | 111 | reserved | 1111   | 111 | tag3 #   |

# Read only



**data unit operation code**

For data unit opcode format A, a 4-bit operation code specifies one of 16 six-operand operations and an associated data path, as shown in Table 16.

**Table 16. Six Operand Format Operation Codes**

| oper FIELD BIT |    |    |    | OPERATION TYPE |
|----------------|----|----|----|----------------|
| 60             | 59 | 58 | 57 |                |
| 0              | u  | 0  | s  | MPY    ADD     |
| 0              | u  | 1  | f  | MPYU    EALU   |
| 1              | 0  | f  | k  | EALU    ROTATE |
| 1              | 0  | 1  | 0  | divi           |
| 1              | 1  | u  | s  | MPY    SADD    |

Legend:

- u Unsigned
- f 1s complement EALU function code
- s Subtract
- k Use mask or mf expander

**operation class code**

The base set ALU opcodes (formats B, C, D) use an operation class code to specify one of eight different routings to the A, B, and C ports of the ALU, as shown in Table 17.

**Table 17. Base Set ALU Class Summary**

| CLASS | DESTINATION | A PORT | B PORT       | C PORT |
|-------|-------------|--------|--------------|--------|
| 000   | dst         | src2   | src1         | @mf    |
| 001   | dst         | dstc   | src1 \\ d0   | src2   |
| 010   | dst         | dstc   | src1         | %src2  |
| 011   | dst         | dstc   | src1 \\ src2 | %src2  |
| 100   | dst         | src2   | src1 \\ d0   | %d0    |
| 101   | dst         | src2   | src1 \\ d0   | @mf    |
| 110   | dst         | dstc   | src1         | src2   |
| 111   | dst         | src1   | 1 \\ src2    | src2   |

Legend:

- \\ Rotate left
- @mf Expand function
- % Mask generation
- dstc Companion D reg
- dst Destination Dreg or any reg if dstbank or Adstbnk is used with destination.
- src2 Source D reg or immediate
- srd1 Source D reg or any if As1bank is used or any lower reg if s1bnk is used

# TMS320C80 DIGITAL SIGNAL PROCESSOR

SPRS023B – JULY 1994 – REVISED OCTOBER 1997

## ALU-operation code

For base-set ALU Boolean opcodes (A=0), the ALU function is formed by a sum of Boolean products selected by the ALU operation opcode bits as shown in Table 18. For base-set arithmetic opcodes (A=1), the four odd ALU operation bits specify an arithmetic operation as described in Table 19 while the four even bits specify one of the ALU function modifiers as shown in Table 20.

**Table 18. Base-Set ALU Boolean Function Codes**

| OPCODE BIT | PRODUCT TERM |
|------------|--------------|
| 58         | A & B & C    |
| 57         | ~A & B & C   |
| 56         | A & ~B & C   |
| 55         | ~A & ~B & C  |
| 54         | A & B & ~C   |
| 53         | ~A & B & ~C  |
| 52         | A & ~B & ~C  |
| 51         | ~A & ~B & ~C |

**Table 19. Base-Set Arithmetics**

| OPCODE BITS |    |    |    | CARRY IN | ALGEBRAIC DESCRIPTION     | NATURAL FUNCTION | MODIFIED FUNCTION (IF DIFFERENT FROM NATURAL FUNCTION) |
|-------------|----|----|----|----------|---------------------------|------------------|--|
| 57          | 55 | 53 | 51 |          |                           |                  |  |
| 0           | 0  | 0  | 0  | x        |                           |                  |  |
| 0           | 0  | 0  | 1  | 1        | A - (B   C)               | A - B <1<        |  |
| 0           | 0  | 1  | 0  | 0        | A + (B & ~C)              | A + B <0<        |  |
| 0           | 0  | 1  | 1  | 1        | A - C                     | A - C            |  |
| 0           | 1  | 0  | 0  | 1        | A - (B   ~C)              | A - B >1>        | (A - (B & C)) if sign=0                                |
| 0           | 1  | 0  | 1  | 1        | A - B                     | A - B            |  |
| 0           | 1  | 1  | 0  | C(n)     | A - (B & @mf   ~B & ~@mf) | A + B / A - B    | if class 0 or 5  |
|             |    |    |    | 1/0      | A +  B                    | A + B / A - B    | if class 1-4 or 6-7, A-B if sign=1                     |
| 0           | 1  | 1  | 1  | 1        | A - (B & C)               | A - B >0>        |  |
| 1           | 0  | 0  | 0  | 0        | A + (B & C)               | A + B >0>        |  |
| 1           | 0  | 0  | 1  | ~C(n)    | A + (B & @mf   ~B & ~@mf) | A - B / A + B    | if class 0 or 5  |
|             |    |    |    | 0/1      | A -  B                    | A - B / A + B    | if class 1-4 or 6-7, A+B if sign=1                     |
| 1           | 0  | 1  | 0  | 0        | A + B                     | A + B            |  |
| 1           | 0  | 1  | 1  | 0        | A + (B   ~C)              | A + B >1>        | (A + (B & C)) if sign=0                                |
| 1           | 1  | 0  | 0  | 0        | A + C                     | A + C            |  |
| 1           | 1  | 0  | 1  | 1        | A - (B & ~C)              | A - B <0<        |  |
| 1           | 1  | 1  | 0  | 0        | A + (B   C)               | A + B <1<        |  |
| 1           | 1  | 1  | 1  | 0        | (A & C) + (B & C)         | field A + B      |  |

Legend:

- C(n) LSB of each part of C port register
- >0> Zero-extend shift right
- <0< Zero-extend shift left
- >1> One-extend shift right
- <1< One-extend shift left



ALU-operation code (continued)

Table 20. Function Modifier Codes

| FUNCTION MODIFIER BITS |    |    |    | MODIFICATION PERFORMED  |
|------------------------|----|----|----|---|
| 58                     | 56 | 54 | 52 |   |
| 0                      | 0  | 0  | 0  | Normal operation  |
| 0                      | 0  | 0  | 1  | cin   |
| 0                      | 0  | 1  | 0  | %! if maskgen instruction, lmo if not maskgen                               |
| 0                      | 0  | 1  | 1  | %! and cin if maskgen instruction, rmo if not maskgen                       |
| 0                      | 1  | 0  | 0  | A port = 0  |
| 0                      | 1  | 0  | 1  | A port = 0 and cin  |
| 0                      | 1  | 1  | 0  | A port = 0 and %! if maskgen, lmbc if not maskgen                           |
| 0                      | 1  | 1  | 1  | A port = 0, %! and cin if maskgen, rmbc if not maskgen                      |
| 1                      | 0  | 0  | 0  | mf bit(s) set by carry out(s). (mc)   |
| 1                      | 0  | 0  | 1  | mf bit(s) set based on status register MSS field. (me)                      |
| 1                      | 0  | 1  | 0  | Rotate mf by Asize, mf bit(s) set by carry out(s). (mrc)                    |
| 1                      | 0  | 1  | 1  | Rotate mf by Asize, mf bit(s) set based on status register MSS field. (mre) |
| 1                      | 1  | 0  | 0  | Clear mf, mf bit(s) set by carry out(s). (mzc)                              |
| 1                      | 1  | 0  | 1  | Clear mf, mf bit(s) set based on status register MSS field. (mze)           |
| 1                      | 1  | 1  | 0  | No setting of bits in mf register. (mx)                                     |
| 1                      | 1  | 1  | 1  | Reserved  |

Legend:

|      |                     |      |                         |
|------|---------------------|------|-------------------------|
| cin  | Carry in from sr(C) | %!   | Modified mask generator |
| lmbc | Leftmost-bit change | rmbc | Rightmost-bit change    |
| lmo  | Leftmost one        | rmo  | Rightmost one           |

miscellaneous operation code

For data-unit opcode format E, the operation field selects one of the miscellaneous operations codes as shown in Table 21.

Table 21. Miscellaneous Operation Codes

| OPCODE BITS |    |    |    |    | MNEMONIC | OPERATION                                   |
|-------------|----|----|----|----|----------|---|
| 43          | 42 | 41 | 40 | 39 |          |   |
| 0           | 0  | 0  | 0  | 0  | nop      | No data-unit operation. Status not modified |
| 0           | 0  | 0  | 0  | 1  | qwait    | Wait until comm Q bit is clear              |
| 0           | 0  | 0  | 1  | 0  | eint     | Global-interrupt enable                     |
| 0           | 0  | 0  | 1  | 1  | dint     | Global-interrupt disable                    |
| 0           | 0  | 1  | 0  | 0  | eloop    | Global loop enable                          |
| 0           | 0  | 1  | 0  | 1  | dloop    | Global loop disable                         |
| 0           | 0  | 1  | 1  | x  | reserved |   |
| 0           | 1  | x  | x  | x  | reserved |   |
| 1           | x  | x  | x  | x  | reserved |   |

**addressing-mode codes**

The Lmode (bits 35–38) and Gmode (bits 13–16) of the opcode specify the local and global transfer for various parallel transfer opcode formats (Lmode in formats 1, 2, 3, 4, and 6 and Gmode in formats 1, 5, and 9). Table 22 shows the coding for the addressing-mode fields.

**Table 22. Addressing-Mode Codes**

| CODING | EXPRESSION    | DESCRIPTION                                    |
|--------|---------------|--|
| 00xx   |               | Nop (nonaddressing mode operation)             |
| 0100   | *(an ++= xm)  | Postaddition of index register, with modify    |
| 0101   | *(an --= xm)  | Postsubtraction of index register, with modify |
| 0110   | *(an ++= imm) | Postaddition of immediate, with modify         |
| 0111   | *(an --= imm) | Postsubtraction of immediate, with modify      |
| 1000   | *(an + xm)    | Preaddition of index register                  |
| 1001   | *(an - xm)    | Presubtraction of index register               |
| 1010   | *(an + imm)   | Preaddition of immediate                       |
| 1011   | *(an - imm)   | Presubtraction of immediate                    |
| 1100   | *(an += xm)   | Preaddition of index register, with modify     |
| 1101   | *(an -= xm)   | Presubtraction of index register, with modify  |
| 1110   | *(an += imm)  | Preaddition of immediate, with modify          |
| 1111   | *(an -= imm)  | Presubtraction of immediate, with modify       |

Legend:

- an Address register in l/g address unit
- imm Immediate offset
- xm Index register in same unit as an register

**L, e codes**

The L and e bits combine to specify the type of parallel transfer performed, as shown in Table 23. For the local transfer, L and e are bits 21 and 31, respectively. For the global transfer, L and e are bits 17 and 9, respectively.

**Table 23. Parallel Transfer Type**

| L | e | PARALLEL TRANSFER       |
|---|---|-------------------------|
| 1 | 0 | Zero-extend load        |
| 1 | 1 | Sign-extend load        |
| 0 | 0 | Store                   |
| 0 | 1 | Address unit arithmetic |

**size codes**

The size code specifies the data transfer size. For field moves (parallel transfer format 3), only byte and halfword data sizes are valid, as shown in Table 24.

**Table 24. Transfer Data Size**

| CODING | DATA SIZE          |
|--------|--------------------|
| 00     | Byte (8 bits)      |
| 01     | Halfword (16 bits) |
| 10     | Word (32 bits)     |
| 11     | Reserved           |

### relative-addressing mode codes

The Lrm and Grm opcode fields allow the local-address or global-address units, respectively, to select PP-relative addressing as shown in Table 25.

**Table 25. Relative-Addressing Mode Codes**

| CODING | RELATIVE-ADDRESSING MODE     |
|--------|------------------------------|
| 00     | Normal (absolute addressing) |
| 01     | Reserved                     |
| 10     | PP-relative dba              |
| 11     | PP-relative pba              |

Legend:

dba – Data RAM 0 base is base address

pba – Parameter RAM base is base address

### condition codes

In the four conditional parallel transfer opcodes (formats 7–10), the condition code field specifies one of 16 condition codes to be applied to the data-unit operation source, data-unit result, or global transfer based on the setting of the c, r, and g bits, respectively. Table 26 shows the condition codes. For the 32-bit immediate data unit opcode (format D), the condition applies to the data-unit result only.

**Table 26. Condition Codes**

| CONDITION BITS |    |    |    | MNEMONIC | DESCRIPTION                | STATUS BIT COMBINATION  |
|----------------|----|----|----|----------|----------------------------|---|
| 35             | 34 | 33 | 32 |          |                            |   |
| 0              | 0  | 0  | 0  | u        | Unconditional (default)    | None  |
| 0              | 0  | 0  | 1  | p        | Positive                   | $\sim N \ \& \ \sim Z$  |
| 0              | 0  | 1  | 0  | ls       | Lower than or same         | $\sim C \   \ Z$  |
| 0              | 0  | 1  | 1  | hi       | Higher than                | $C \ \& \ \sim Z$   |
| 0              | 1  | 0  | 0  | lt       | Less than                  | $(N \ \& \ \sim V) \   \ (\sim N \ \& \ V)$                             |
| 0              | 1  | 0  | 1  | le       | Less than or equal         | $(N \ \& \ \sim V) \   \ (\sim N \ \& \ V) \   \ Z$                     |
| 0              | 1  | 1  | 0  | ge       | Greater than or equal      | $(N \ \& \ V) \   \ (\sim N \ \& \ \sim V)$                             |
| 0              | 1  | 1  | 1  | gt       | Greater than               | $(N \ \& \ V \ \& \ \sim Z) \   \ (\sim N \ \& \ \sim V \ \& \ \sim Z)$ |
| 1              | 0  | 0  | 0  | hs, c    | Higher than or same, carry | C   |
| 1              | 0  | 0  | 1  | lo, nc   | Lower than, no carry       | $\sim C$  |
| 1              | 0  | 1  | 0  | eq, z    | Equal, zero                | Z   |
| 1              | 0  | 1  | 1  | ne, nz   | Not equal, not zero        | $\sim Z$  |
| 1              | 1  | 0  | 0  | v        | Overflow                   | V   |
| 1              | 1  | 0  | 1  | nv       | No overflow                | $\sim V$  |
| 1              | 1  | 1  | 0  | n        | Negative                   | N   |
| 1              | 1  | 1  | 1  | nn       | Nonnegative                | $\sim N$  |

### EALU operations

Extended ALU (EALU) operations allow the execution of more advanced ALU functions than those specified in the base set ALU opcodes. The opcode for EALU instructions contains the operands for the operation while the d0 register extends the opcode by specifying the EALU operation to be performed. The format of d0 for EALU operations is shown in Figure 24.

**EALU Boolean functions**

EALU operations support all 256 Boolean ALU functions plus the flexibility to add 1 or a carry-in to Boolean sum. The Boolean function performed by the ALU are shown below and in Table 27.

$$\left( \begin{array}{l} (F0 \& (\sim A \& \sim B \& \sim C)) \\ (F3 \& (A \& B \& \sim C)) \\ (F6 \& (\sim A \& B \& C)) \end{array} \right) \left| \left( \begin{array}{l} (F1 \& (A \& \sim B \& \sim C)) \\ (F4 \& (\sim A \& \sim B \& C)) \\ (F7 \& (A \& B \& C)) \end{array} \right) \left| \left( \begin{array}{l} (F2 \& (\sim A \& B \& \sim C)) \\ (F5 \& (A \& \sim B \& C)) \end{array} \right) \right. \left. [+1 \mid +cin] \right.$$

**Table 27. EALU Boolean Function Codes**

| d0 BIT | ALU FUNCTION SIGNAL | PRODUCT TERM |
|--------|---------------------|--------------|
| 26     | F7                  | A & B & C    |
| 25     | F6                  | ~A & B & C   |
| 24     | F5                  | A & ~B & C   |
| 23     | F4                  | ~A & ~B & C  |
| 22     | F3                  | A & B & ~C   |
| 21     | F2                  | ~A & B & ~C  |
| 20     | F1                  | A & ~B & ~C  |
| 19     | F0                  | ~A & ~B & ~C |

**EALU arithmetic functions**

EALU operations support all 256 arithmetic functions provided by the three-input ALU plus the flexibility to add 1 or a carry-in to the result. The arithmetic function performed by the ALU is:

$$f(A,B,C) = A \& f1(B,C) + f2(B,C) [+1 \mid cin]$$

f1(B,C) and f2(B,C) are independent Boolean combinations of the B and C ALU inputs. The ALU function is specified by selecting the desired f1 and f2 subfunction and then XORing the f1 and f2 code from Table 28 to create the ALU function code for bits 19–26 of d0. Additional operations such as absolute values and signed shifts can be performed using d0 bits which control the ALU function based on the sign of one of the inputs.

**Table 28. ALU f1(B,C) and f2(B,C) Subfunctions**

| f1 CODE | f2 CODE | SUBFUNCTION               | COMMON USAGE  |
|---------|---------|---------------------------|---|
| 00      | 00      | 0                         | Zero the term   |
| AA      | FF      | –1                        | –1 (All 1s)   |
| 88      | CC      | B                         | B   |
| 22      | 33      | –B –1                     | Negate B  |
| A0      | F0      | C                         | C   |
| 0A      | 0F      | –C –1                     | Negate C  |
| 80      | C0      | B & C                     | Force bits in B to 0 where bits in C are 0            |
| 2A      | 3F      | –(B & C) – 1              | Force bits in B to 0 where bits in C are 0 and negate |
| A8      | FC      | B   C                     | Force bits in B to 1 where bits in C are 1            |
| 02      | 03      | –(B   C) – 1              | Force bits in B to 1 where bits in C are 1 and negate |
| 08      | 0C      | B & ~C                    | Force bits in B to 0 where bits in C are 1            |
| A2      | F3      | –(B & ~C) –1              | Force bits in B to 0 where bits in C are 1 and negate |
| 8A      | CF      | B   ~C                    | Force bits in B to 1 where bits in C are 0            |
| 20      | 30      | –(B   ~C) –1              | Force bits in B to 1 where bits in C are 0 and negate |
| 28      | 3C      | (B & ~C)   ((–B – 1) & C) | Choose B if C = all 0s and –B if C = all 1s           |
| 82      | C3      | (B & C)   ((–B – 1) & ~C) | Choose B if C = all 1s and –B if C = all 0s           |

## video controller architecture

The video controller (VC) provides a method for handling the video or graphics capture, or display portions of a TMS320C80 system. It provides simultaneous control over two independent capture or display systems and frame grabber or frame buffer image storage.

### VC functional block diagram

Figure 46 shows a functional block diagram of the video controller. Key features of the VC include:

- Dual-frame timers
  - Independent or locked operation
  - Programmable horizontal and vertical timing
  - Separate or composite sync and blanking control
  - Synchronization to external timing signals
  - Interlaced or noninterlaced frame control
  - Virtually limitless screen resolutions
- Programmable timing and control registers
- Programmable line interrupt to MP
- Shift register transfer (SRT) controller
  - Generates VRAM serial register transfer requests to the TC
  - Tracks VRAM tap point and schedules midline reloads
  - Generates packet-transfer requests for DRAM-based buffer updates
  - Supports two display or capture buffers

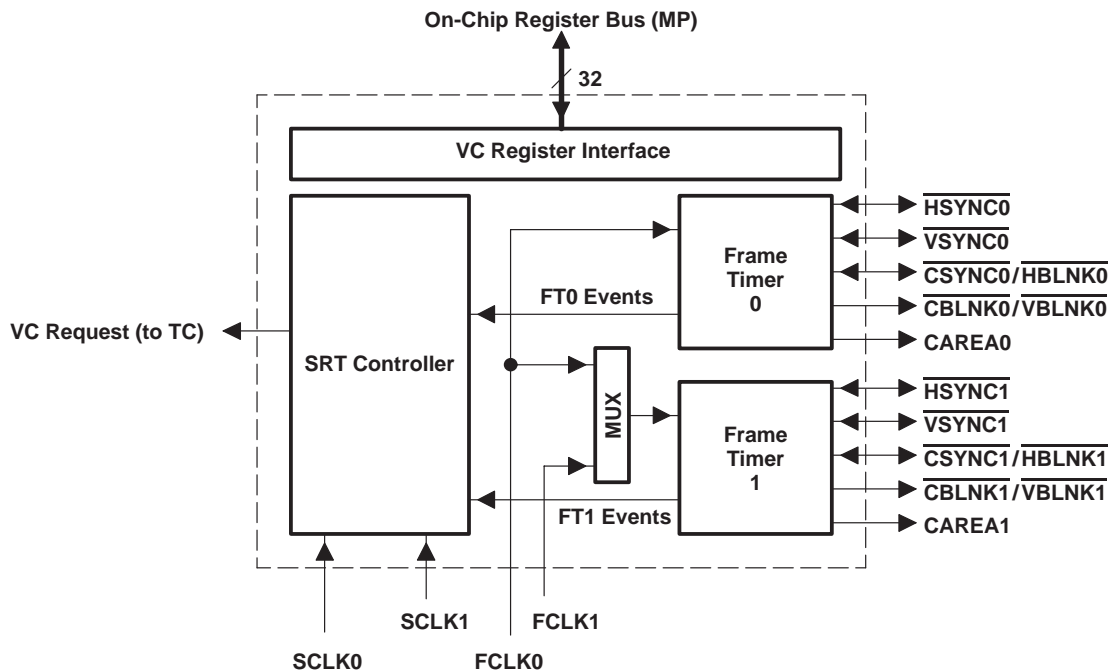

Figure 46. VC Block Diagram

**frame-timer registers**

Each frame timer has twenty-one 16-bit registers to control its horizontal and vertical timing signals. The registers are on-chip memory-mapped registers accessible by the MP only. Each horizontal/vertical register pair can be accessed as a single 32-bit quantity. The register map for Frame-Timer 0 is shown in Figure 47. The Frame-Timer 1 register map is shown in Figure 48.

|         | Address    |         | Address    |
|---------|------------|---------|------------|
| SETVCT0 | 0x01820206 | FTCTL0  | 0x01820200 |
| VFTINT0 | 0x0182020A | SETHCT0 | 0x01820204 |
| VESYNC0 | 0x0182020E | HESERR0 | 0x01820208 |
| VEBLNK0 | 0x01820212 | HESYNC0 | 0x0182020C |
| VSAREA0 | 0x01820216 | HEBLNK0 | 0x01820210 |
| VEAREA0 | 0x0182021A | HSAREA0 | 0x01820214 |
| VSBLNK0 | 0x0182021E | HEAREA0 | 0x01820218 |
| VTOTAL0 | 0x01820222 | HSBLNK0 | 0x0182021C |
|         |            | HTOTAL0 | 0x01820220 |
|         |            | HALINE0 | 0x01820224 |
|         |            | HBLINE0 | 0x01820228 |
| VCOUNT0 | 0x0182023E | HCOUNT0 | 0x0182023C |

**Figure 47. Frame-Timer 0 Register Map**

|         | Address    |         | Address    |
|---------|------------|---------|------------|
| SETVCT1 | 0x01820246 | FTCTL1  | 0x01820240 |
| VFTINT1 | 0x0182024A | SETHCT1 | 0x01820244 |
| VESYNC1 | 0x0182024E | HESERR1 | 0x01820248 |
| VEBLNK1 | 0x01820252 | HESYNC1 | 0x0182024C |
| VSAREA1 | 0x01820256 | HEBLNK1 | 0x01820250 |
| VEAREA1 | 0x0182025A | HSAREA1 | 0x01820254 |
| VSBLNK1 | 0x0182025E | HEAREA1 | 0x01820258 |
| VTOTAL1 | 0x01820262 | HSBLNK1 | 0x0182025C |
|         |            | HTOTAL1 | 0x01820260 |
|         |            | HALINE1 | 0x01820264 |
|         |            | HBLINE1 | 0x01820268 |
| VCOUNT1 | 0x0182027E | HCOUNT1 | 0x0182027C |

**Figure 48. Frame-Timer 1 Register Map**

**frame-timer register programming**

The register format for the frame-timer control registers is shown in Figure 49. All other registers are 16-bit values. For programming details, see the *TMS320C80 Video Controller User's Guide* (literature number SPRU111).

### frame-timer control (FTCTLx) register

The FTCTLx register contains mode bits to determine frame-timer behavior.

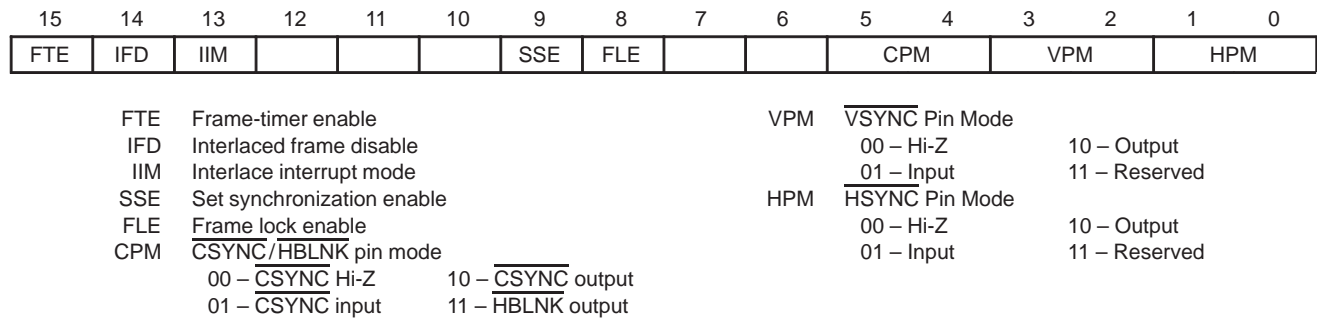

Figure 49. FTCTLx Register

### SRT controller registers

The SRT controller has two sets of 32-bit registers, one for each of the supported frame memory regions. The location of these registers in on-chip memory-mapped register space is shown in Figure 50.

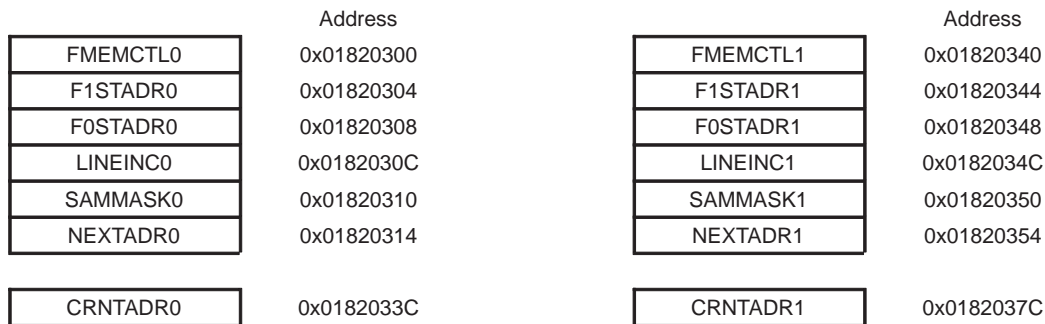

Figure 50. SRT Controller Register Map

### SRT controller register programming

The register format for the frame memory control registers is shown in Figure 51. All other registers are 32-bit values. For programming details, see the *TMS320C80 Video Controller User's Guide* (literature number SPRU111).

#### FMEMCTLx Register

The frame memory control (FMEMCTLx) register contains mode bits to determine operation of the associated frame memory.

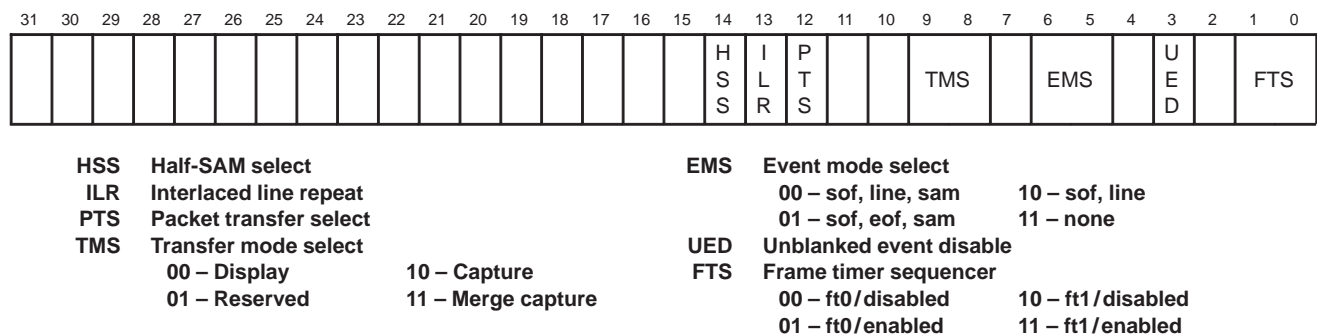

Figure 51. FMEMCTLx Register

## TC architecture

The transfer controller (TC) is a combined memory controller and DMA (direct memory access) machine. It handles the movement of data within the 'C80 system as requested by the master processor, parallel processors, video controller, and external devices. The transfer controller performs the following data movement and memory control functions:

- MP and PP instruction cache fills
- MP data cache fills and dirty block write-back
- MP and PP direct external accesses (DEAs)
- MP and PP packet transfers
- Externally initiated packet transfers (XPTs)
- VC packet transfers (VCPTs)
- VC shift register transfers (SRTs)
- DRAM/SDRAM refresh
- Host bus request

## TC functional block diagram

Figure 52 shows a functional block diagram of the transfer controller. Key features of the TC include:

- Crossbar interface
  - 64-bit data path
  - Single-cycle access
- External memory interface
  - 4G-Byte address range
  - Dynamically configurable memory cycles
    - 8-, 16-, 32-, or 64-bit bus size
    - Selectable memory page size
    - Selectable address multiplexing
    - Selectable cycle timing
  - Big- or little-endian operation
- Cache, VRAM, refresh controller
  - Programmable refresh rate
  - VRAM block write support
- Independent Src and Dst addressing
  - Autonomous addressing based on packet-transfer parameters
  - Data read and write at different rates
  - Numerous data merging and alignment functions performed during transfer
- Intelligent request prioritization

TC functional block diagram (continued)

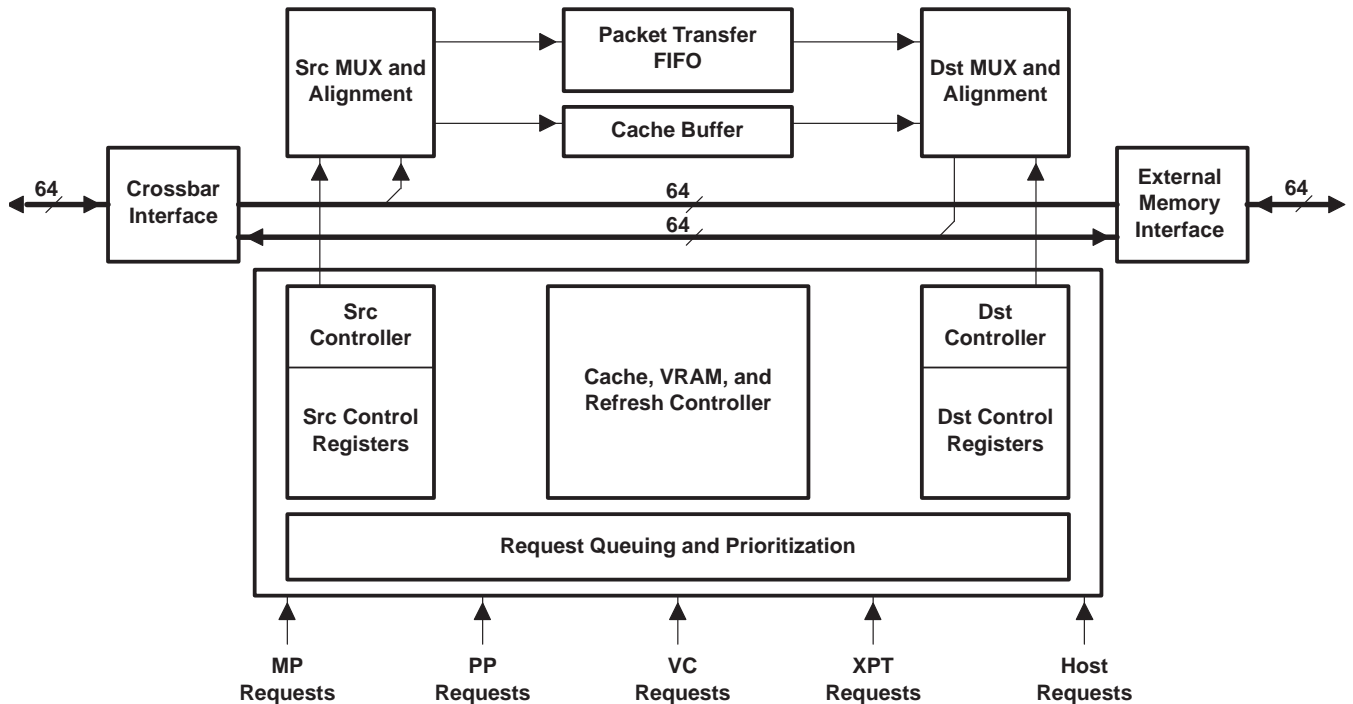

Figure 52. TC Block Diagram

TC registers

The TC contains four on-chip memory-mapped registers accessible by the MP. TC registers are shown in Figure 53.

**refresh control (REFCNTL) register (0x01820000)**

The REFCNTL register controls refresh cycles.

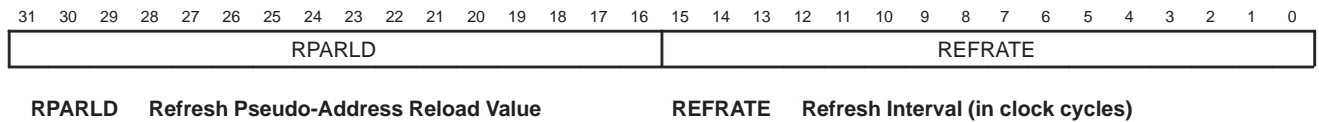

Figure 53. REFCNTL Register

**packet-transfer minimum (PTMIN) register (0x01820004)**

The PTMIN register determines the minimum number of cycles that a packet transfer executes before being suspended by a higher priority packet transfer. Figure 54 shows the PTMIN register.

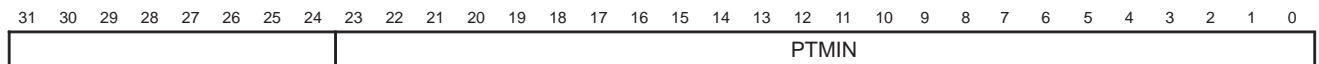

Figure 54. PTMIN Register

# TMS320C80 DIGITAL SIGNAL PROCESSOR

SPRS023B – JULY 1994 – REVISED OCTOBER 1997

## ***PT maximum (PTMAX) register (0x01820008)***

The PTMAX register determines the maximum number of cycles after PTMIN has elapsed that a packet transfer executes before timing out. Figure 55 shows the format of the PTMAX register.

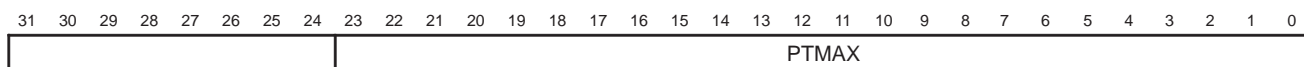

**Figure 55. PTMAX Register**

## ***fault status (FLTSTS) register (0x0182000C)***

The FLTSTS register indicates the cause of a memory access fault. Fault status bits are cleared by writing a 1 to the appropriate bit. Figure 56 shows the format of the fault status (FLTSTS) register.

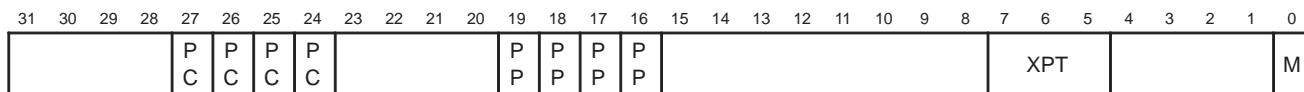

|      |                           |   |   |   |  |     |                          |   |   |   |
|------|---------------------------|---|---|---|--|-----|--------------------------|---|---|---|
| PP # | 3                         | 2 | 1 | 0 |  | PP# | 3                        | 2 | 1 | 0 |
| PC   | PPx Cache / DEA Fault     |   |   |   |  | XPT | Faulting XPT             |   |   |   |
| PP   | PPx Packet-Transfer Fault |   |   |   |  | M   | MP Packet-Transfer Fault |   |   |   |

**Figure 56. FLTSTS Register**

## **packet-transfer parameters**

The most efficient method for data movement in a TMS320C80 system is through the use of packet transfers (PTs). Packet transfers allow the TC to move blocks of data autonomously between a specified src and dst memory region. Requests for the TC to execute a packet transfer may be made by the MP, PPs, VC, or external devices. A packet-transfer parameter table describing the data packet and how it is to be transferred must be programmed in on-chip memory before the transfer is requested. The parameter table formats for long-form and short-form packet transfers are shown in Figure 57.



packet-transfer parameters (continued)

| Byte Address | Long-Form Parameter Table |             | Word Number | Byte Address  | Short-Form Parameter Table |       | Word Number |
|--------------|---------------------------|-------------|-------------|---|----------------------------|-------|-------------|
|              | 31                        | 0           |             |   | 31                         | 0     |             |
| PT           | Next Entry Address        |             | 0           | PT  | Next Entry Address         |       | 0           |
| PT+4         | PT Options                |             | 1           | PT+4  | PT Options                 | Count | 1           |
| PT+8         | Src Start Address         |             | 0           | PT+8  | Src Start Address          |       | 0           |
| PT+12        | Dst Start Address         |             | 1           | PT+12   | Dst Start Address          |       | 1           |
| PT+16        | Src B Count               | Src A Count | 0           | PT - 16-byte aligned on-chip starting address of parameter table. |                            |       |             |
| PT+20        | Dst B Count               | Dst A Count | 1           |   |                            |       |             |
| PT+24        | Src C Count               |             | 0           |   |                            |       |             |
| PT+28        | Dst C Count               |             | 1           |   |                            |       |             |
| PT+32        | Src B Pitch               |             | 0           |   |                            |       |             |
| PT+36        | Dst B Pitch               |             | 1           |   |                            |       |             |
| PT+40        | Src C Pitch               |             | 0           |   |                            |       |             |
| PT+44        | Dst C Pitch               |             | 1           |   |                            |       |             |
| †PT+48       | Transparency/Color Word 0 |             | 0†          |   |                            |       |             |
| †PT+52       | Transparency/Color Word 1 |             | 1†          |   |                            |       |             |
| PT+56        | Don't Care                |             | 0           |   |                            |       |             |
| PT+60        | Don't Care                |             | 1           |   |                            |       |             |

PT - 64-byte aligned on-chip starting address of parameter table.

† These words are swapped in big-endian mode.

Figure 57. Packet-Transfer Parameter Table

# TMS320C80 DIGITAL SIGNAL PROCESSOR

SPRS023B – JULY 1994 – REVISED OCTOBER 1997

## PT-options field

The PT-options field of the parameter table controls the type of src and dst transfer that the TC performs. The formats of the options field for long-form and short-form packet transfers are shown in Figure 58.

### Long-Form PT Options



|     |                                       |         |  |
|-----|---------------------------------------|---------|--|
| S   | Stop Bit                              | PAM     | PT Access Mode   |
| PTS | PT Status                             |         | 000 – Normal      100 – 8-Bit Transparency               |
|     | 00 – Active      10 – Fault on Src    |         | 001 – PDT      101 – 16-Bit Transparency                 |
|     | 01 – Suspended      11 – Fault on Dst |         | 010 – Block Write      110 – 32-Bit Transparency         |
| I   | Stop Bit                              |         | 011 – SRT      111 – 64-Bit Transparency                 |
| RDC | Reverse Dst C Addressing              | STM/DTM | Src/Dst Transfer Mode                                    |
| RDB | Reverse Dst B Addressing              |         | 000 – Dimensioned      100 – Variable, Delta-Guided      |
| RA  | Reverse A Addressing                  |         | 001 – Fill (Src Only)      101 – Variable, Offset-Guided |
| RSC | Reverse Src C Addressing              |         | 010 – Reserved      110 – Fixed, Delta-Guided            |
| RSB | Reverse Src B Addressing              |         | 011 – LUT (Src Only)      111 – Fixed, Offset-Guided     |
| SF  | Short Form                            | SUM/DTM | Src/Dst Update Mode                                      |
| X   | Exchange Src and Dst Parameters       |         | 00 – None      01 – Add C Pitch                          |
|     |                                       |         | 01 – Add B Pitch      11 – Add C Pitch/Reverse           |

### Short-Form PT Options

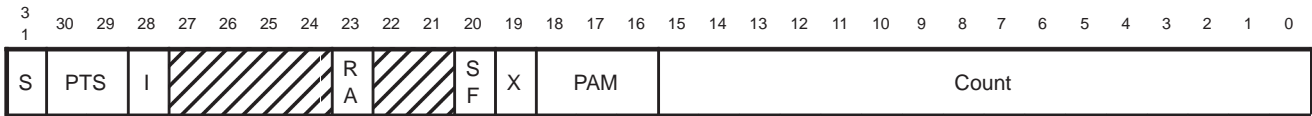

|     |                                       |     |                                    |
|-----|---------------------------------------|-----|------------------------------------|
| S   | Stop Bit                              | RA  | Reverse Addressing                 |
| PTS | PT Status                             | X   | Exchange Src & Dst Parameters      |
|     | 00 – Active      10 – Fault on Src    | PAM | PT Access Mode                     |
|     | 01 – Suspended      11 – Fault on Dst |     | 000 – Normal      100 – Reserved   |
| I   | Stop Bit                              |     | 001 – PDT      101 – Reserved      |
| RA  | Reverse Addressing                    |     | 010 – Reserved      110 – Reserved |
|     |                                       |     | 011 – SRT      111 – Reserved      |

Figure 58. PT-Options Field



LOCAL MEMORY INTERFACE

status codes

Status codes are output on STATUS[5:0] to describe the cycle being performed. During row time, the STATUS[5:0] pins indicate the type of cycle being performed. The cycle type can be latched using  $\overline{RL}$  or  $\overline{RAS}$  and used by external logic to perform memory bank decoding or to enable special hardware features. During column time, the STATUS[5:0] pins indicate the requesting processor or special column information. See Table 29 for a listing of the Row-time status codes and Table 30 for a listing of column-time status codes.

Table 29. Row-Time Status Codes

| STATUS[5:0] | CYCLE TYPE                   | STATUS[5:0] | CYCLE TYPE           |
|-------------|------------------------------|-------------|----------------------|
| 0 0 0 0 0 0 | Normal Read                  | 1 0 0 0 0 0 | Reserved             |
| 0 0 0 0 0 1 | Normal Write                 | 1 0 0 0 0 1 | Reserved             |
| 0 0 0 0 1 0 | Refresh                      | 1 0 0 0 1 0 | Reserved             |
| 0 0 0 0 1 1 | SDRAM DCAB                   | 1 0 0 0 1 1 | Reserved             |
| 0 0 0 1 0 0 | Peripheral Device PT Read    | 1 0 0 1 0 0 | XPT1 Read            |
| 0 0 0 1 0 1 | Peripheral Device PT Write   | 1 0 0 1 0 1 | XPT1 Write           |
| 0 0 0 1 1 0 | Reserved                     | 1 0 0 1 1 0 | XPT1 PDPT Read       |
| 0 0 0 1 1 1 | Reserved                     | 1 0 0 1 1 1 | XPT1 PDPT Write      |
| 0 0 1 0 0 0 | Reserved                     | 1 0 1 0 0 0 | XPT2 Read            |
| 0 0 1 0 0 1 | Block Write PT               | 1 0 1 0 0 1 | XPT2 Write           |
| 0 0 1 0 1 0 | Reserved                     | 1 0 1 0 1 0 | XPT2 PDPT Read       |
| 0 0 1 0 1 1 | Reserved                     | 1 0 1 0 1 1 | XPT2 PDPT Write      |
| 0 0 1 1 0 0 | SDRAM MRS                    | 1 0 1 1 0 0 | XPT3 Read            |
| 0 0 1 1 0 1 | Load Color Register          | 1 0 1 1 0 1 | XPT3 Write           |
| 0 0 1 1 1 0 | Reserved                     | 1 0 1 1 1 0 | XPT3 PDPT Read       |
| 0 0 1 1 1 1 | Reserved                     | 1 0 1 1 1 1 | XPT3 PDPT Write      |
| 0 1 0 0 0 0 | Frame 0 Read Transfer        | 1 1 0 0 0 0 | XPT4/SAM1 Read       |
| 0 1 0 0 0 1 | Frame 0 Write Transfer       | 1 1 0 0 0 1 | XPT4/SAM1 Write      |
| 0 1 0 0 1 0 | Frame 0 Split Read Transfer  | 1 1 0 0 1 0 | XPT4/SAM1 PDPT Read  |
| 0 1 0 0 1 1 | Frame 0 Split Write Transfer | 1 1 0 0 1 1 | XPT4/SAM1 PDPT Write |
| 0 1 0 1 0 0 | Frame 1 Read Transfer        | 1 1 0 1 0 0 | XPT5/SOF1 Read       |
| 0 1 0 1 0 1 | Frame 1 Write Transfer       | 1 1 0 1 0 1 | XPT5/SOF1 Write      |
| 0 1 0 1 1 0 | Frame 1 Split Read Transfer  | 1 1 0 1 1 0 | XPT5/SOF1 PDPT Read  |
| 0 1 0 1 1 1 | Frame 1 Split Write Transfer | 1 1 0 1 1 1 | XPT5/SOF1 PDPT Write |
| 0 1 1 0 0 0 | Reserved                     | 1 1 1 0 0 0 | XPT6/SAM0 Read       |
| 0 1 1 0 0 1 | Reserved                     | 1 1 1 0 0 1 | XPT6/SAM0 Write      |
| 0 1 1 0 1 0 | Reserved                     | 1 1 1 0 1 0 | XPT6/SAM0 PDPT Read  |
| 0 1 1 0 1 1 | Reserved                     | 1 1 1 0 1 1 | XPT6/SAM0 PDPT Write |
| 0 1 1 1 0 0 | PT Read Transfer             | 1 1 1 1 0 0 | XPT7/SOF0 Read       |
| 0 1 1 1 0 1 | PT Write Transfer            | 1 1 1 1 0 1 | XPT7/SOF0 Write      |
| 0 1 1 1 1 0 | Reserved                     | 1 1 1 1 1 0 | XPT7/SOF0 PDPT Read  |
| 0 1 1 1 1 1 | Idle                         | 1 1 1 1 1 1 | XPT7/SOF0 PDPT Write |

# TMS320C80 DIGITAL SIGNAL PROCESSOR

SPRS023B – JULY 1994 – REVISED OCTOBER 1997

## status codes (continued)

**Table 30. Column-Time Status Codes**

| STATUS[5:0] | CYCLE TYPE                        | STATUS[5:0] | CYCLE TYPE               |
|-------------|-----------------------------------|-------------|--------------------------|
| 0 0 0 0 0 0 | PP0 Low Priority Packet Transfer  | 1 0 0 0 0 0 | Reserved                 |
| 0 0 0 0 0 1 | PP0 High Priority Packet Transfer | 1 0 0 0 0 1 | Reserved                 |
| 0 0 0 0 1 0 | PP0 Instruction Cache             | 1 0 0 0 1 0 | Reserved                 |
| 0 0 0 0 1 1 | PP0 DEA                           | 1 0 0 0 1 1 | Reserved                 |
| 0 0 0 1 0 0 | PP1 Low Priority Packet Transfer  | 1 0 0 1 0 0 | Reserved                 |
| 0 0 0 1 0 1 | PP1 High Priority Packet Transfer | 1 0 0 1 0 1 | Reserved                 |
| 0 0 0 1 1 0 | PP1 Instruction Cache             | 1 0 0 1 1 0 | Reserved                 |
| 0 0 0 1 1 1 | PP1 DEA                           | 1 0 0 1 1 1 | Reserved                 |
| 0 0 1 0 0 0 | PP2 Low Priority Packet Transfer  | 1 0 1 0 0 0 | Reserved                 |
| 0 0 1 0 0 1 | PP2 High Priority Packet Transfer | 1 0 1 0 0 1 | Reserved                 |
| 0 0 1 0 1 0 | PP2 Instruction Cache             | 1 0 1 0 1 0 | Reserved                 |
| 0 0 1 0 1 1 | PP2 DEA                           | 1 0 1 0 1 1 | Reserved                 |
| 0 0 1 1 0 0 | PP3 Low Priority Packet Transfer  | 1 0 1 1 0 0 | Reserved                 |
| 0 0 1 1 0 1 | PP3 High Priority Packet Transfer | 1 0 1 1 0 1 | Reserved                 |
| 0 0 1 1 1 0 | PP3 Instruction Cache             | 1 0 1 1 1 0 | Reserved                 |
| 0 0 1 1 1 1 | PP3 DEA                           | 1 0 1 1 1 1 | Reserved                 |
| 0 1 0 0 0 0 | MP Low Priority Packet Transfer   | 1 1 0 0 0 0 | Reserved                 |
| 0 1 0 0 0 1 | MP High Priority Packet Transfer  | 1 1 0 0 0 1 | Reserved                 |
| 0 1 0 0 1 0 | MP Urgent Packet Transfer (Low)   | 1 1 0 0 1 0 | Reserved                 |
| 0 1 0 0 1 1 | MP Urgent Packet Transfer (High)  | 1 1 0 0 1 1 | Reserved                 |
| 0 1 0 1 0 0 | XPT/VCPT in Progress              | 1 1 0 1 0 0 | Reserved                 |
| 0 1 0 1 0 1 | XPT/VCPT Complete                 | 1 1 0 1 0 1 | Reserved                 |
| 0 1 0 1 1 0 | MP Instruction Cache (Low)        | 1 1 0 1 1 0 | Reserved                 |
| 0 1 0 1 1 1 | MP Instruction Cache (High)       | 1 1 0 1 1 1 | Reserved                 |
| 0 1 1 0 0 0 | MP DEA (Low)                      | 1 1 1 0 0 0 | Reserved                 |
| 0 1 1 0 0 1 | MP DEA (High)                     | 1 1 1 0 0 1 | Reserved                 |
| 0 1 1 0 1 0 | MP Data Cache (Low)               | 1 1 1 0 1 0 | Reserved                 |
| 0 1 1 0 1 1 | MP Data Cache (High)              | 1 1 1 0 1 1 | Reserved                 |
| 0 1 1 1 0 0 | Frame 0                           | 1 1 1 1 0 0 | Reserved                 |
| 0 1 1 1 0 1 | Frame 1                           | 1 1 1 1 0 1 | Reserved                 |
| 0 1 1 1 1 0 | Refresh                           | 1 1 1 1 1 0 | Reserved                 |
| 0 1 1 1 1 1 | Idle                              | 1 1 1 1 1 1 | Write Drain / SDRAM DCAB |

Low – MP operating in low (normal) priority mode  
High – MP operating in high priority mode



### address multiplexing

To support various RAM devices, the TMS320C80 can provide multiplexed row and column addresses on its address bus. A full 32-bit address is always output at row time. The alignment of column addresses is configured by the value input on the AS[2:0] pins at row time (see Figure 59).

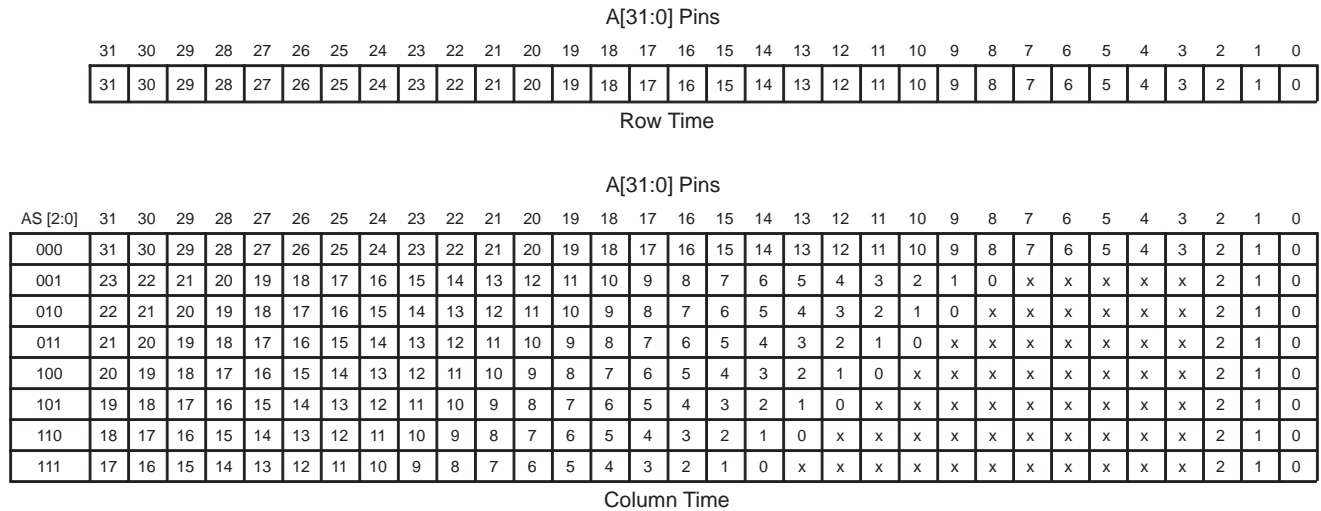

**Figure 59. Address Multiplexing**

### dynamic bus sizing

The 'C80 supports data bus sizes of 8, 16, 32, or 64 bits as shown in Table 31. The value input on the BS[1:0] pins at row time indicates the bus size of the addressed memory. This determines the maximum number of bytes which the 'C80 can transfer during each column access. If the number of bytes to be transferred exceeds the bus size, multiple accesses are performed automatically to complete the transfer.

**Table 31. Bus Size Selection**

| BS[1:0] | BUS SIZE |
|---------|----------|
| 0 0     | 8 bits   |
| 0 1     | 16 bits  |
| 1 0     | 32 bits  |
| 1 1     | 64 bits  |

The selected bus size also determines which portion of the data bus is used for the transfer. For 64-bit memory, the entire data bus is used. For 32-bit memory, D[31:0] are used in little-endian mode and D[63:32] are used in big-endian mode. 16-bit buses use D[15:0] and D[63:48] and 8-bit buses use D[7:0] and D[63:56] for little- and big-endian modes, respectively. The 'C80 always aligns data to the proper portion of the bus and activates the appropriate CAS/DQM strobes to ensure that only valid bytes are transferred.

**cycle time selection**

The 'C80 supports eight basic sets of memory timings to support various memory types directly. The cycle timing is selected by the value input on the CT[2:0] and  $\overline{UTIME}$  pins at row time. The selected timing remains in effect until the next row access. See Table 32 for Cycle-timing selections.

**Table 32. Cycle-Timing Selection**

| $\overline{UTIME}$ | CT[2:0] | MEMORY TIMING                             |
|--------------------|---------|---|
| 0                  | 0 0 0   | Reserved                                  |
| 0                  | 0 0 1   | SDRAM: burst length 1, read latency 4     |
| 0                  | 0 1 0   | Reserved                                  |
| 0                  | 0 1 1   | SDRAM: burst length 2, read latency 4     |
| 0                  | 1 0 0   | User timed DRAM: pipelined 1 cycle/column |
| 0                  | 1 0 1   | User timed DRAM: 1 cycle/column           |
| 0                  | 1 1 0   | User timed DRAM: 2 cycle/column           |
| 0                  | 1 1 1   | User timed DRAM: 3 cycle/column           |
| 1                  | 0 0 0   | SDRAM: burst length 1, read latency 2     |
| 1                  | 0 0 1   | SDRAM: burst length 1, read latency 3     |
| 1                  | 0 1 0   | SDRAM: burst length 2, read latency 2     |
| 1                  | 0 1 1   | SDRAM: burst length 2, read latency 3     |
| 1                  | 1 0 0   | DRAM: pipelined 1 cycle/column            |
| 1                  | 1 0 1   | DRAM: 1 cycle/column                      |
| 1                  | 1 1 0   | DRAM: 2 cycle/column                      |
| 1                  | 1 1 1   | DRAM: 3 cycle/column                      |

**page sizing**

Whenever an external memory access occurs, the TC records the 26 most significant bits of the address in its internal LASTPAGE register. The address of each subsequent (column) access is compared to this value. The page size value input on the PS[3:0] pins determines which bits of LASTPAGE are used for this comparison. If a difference exists between the enabled LASTPAGE bits and the corresponding bits of the next access then the page has changed and the next memory access begins with a new row-address cycle (see Table 33).

page sizing (continued)

Table 33. Page-Size Selection

| PS[3:0] | ADDRESS BITS COMPARED | PAGE SIZE (BYTES) |
|---------|-----------------------|-------------------|
| 0 0 0 0 | A(31:6)               | 64                |
| 0 0 0 1 | A(31:7)               | 128               |
| 0 0 1 0 | A(31:8)               | 256               |
| 0 0 1 1 | A(31:9)               | 512               |
| 0 1 0 0 | A(31:10)              | 1K                |
| 0 1 0 1 | A(31:18)              | 256K              |
| 0 1 1 0 | A(31:19)              | 512K              |
| 0 1 1 1 | A(31:20)              | 1M                |
| 1 0 0 0 | A(31:0)               | 1–8†              |
| 1 0 0 1 | A(31:11)              | 2K                |
| 1 0 1 0 | A(31:12)              | 4K                |
| 1 0 1 1 | A(31:13)              | 8K                |
| 1 1 0 0 | A(31:14)              | 16K               |
| 1 1 0 1 | A(31:15)              | 32K               |
| 1 1 1 0 | A(31:16)              | 64K               |
| 1 1 1 1 | A(31:17)              | 128K              |

† PS[3:0] = 1000 disables page-mode cycles so that the effective page size is the same as the bus size

block write support

The TMS320C80 supports three modes of VRAM block write. The block-write mode is dynamically selectable so that software may specify block writes without knowing what type of block write the addressed memory supports. Block writes are supported only for 64-bit buses. During block-write and load-color-register cycles, the BS[1:0] inputs determine which block mode will be used (see Table 34).

Table 34. Block-Write Selection

| BS[1:0] | BLOCK-WRITE MODE |
|---------|------------------|
| 0 0     | Simulated        |
| 0 1     | Reserved         |
| 1 0     | 4x               |
| 1 1     | 8x               |

SDRAM support

The TMS320C80 provides direct support for synchronous DRAM (SDRAM), VRAM (SVRAM), and graphics RAM (SGRAM). During 'C80 power-up refresh cycles, the external system must signal the presence of these memories by inputting a CT2 value of 0. This causes the 'C80 to perform special deactivate (DCAB) and mode register set (MRS) commands to initialize the synchronous RAMs. Figure 60 shows the MRS value generated by the 'C80. Note that read latency 4 timing programs the mode register for a read latency of 3. See Figure 60 for a listing of MRS values.

# TMS320C80 DIGITAL SIGNAL PROCESSOR

SPRS023B – JULY 1994 – REVISED OCTOBER 1997

## SDRAM support (continued)

| SDRAM Mode Register Bit | 11 | 10 | 9  | 8 | 7 | 6            | 5     | 4         | 3   | 2            | 1 | 0   |
|-------------------------|----|----|----|---|---|--------------|-------|-----------|-----|--------------|---|-----|
| Meaning                 |    |    | WB | 0 | 0 | Read Latency |       |           | S/I | Burst Length |   |     |
| Value                   | 0  | 0  | 0  | 0 | 0 | !(UTIME)     | UTIME | UTIME&CT0 | 0   | 0            | 0 | CT1 |

UTIME, CT0, CT1 values as input at the start of the MRS cycle

**Figure 60. MRS Value**

Because the MRS register is programmed through the SDRAM address inputs, the alignment of the MRS data to the 'C80 logical-address bits is adjusted for the bus size (see Figure 61). The appearance of the MRS bits on the 'C80 physical-address bus is dependent on the address multiplexing as selected by the AS[2:0] inputs.

| BS[1:0] | 'C80 LOGICAL ADDRESS BITS |     |     |     |     |     |    |    |    |    |    |    |    |    |    |    |
|---------|---------------------------|-----|-----|-----|-----|-----|----|----|----|----|----|----|----|----|----|----|
|         | A15                       | A14 | A13 | A12 | A11 | A10 | A9 | A8 | A7 | A6 | A5 | A4 | A3 | A2 | A1 | A0 |
| 0 0     | X                         | X   | X   | X   | 11  | 10  | 9  | 8  | 7  | 6  | 5  | 4  | 3  | 2  | 1  | 0  |
| 0 1     | X                         | X   | X   | 11  | 10  | 9   | 8  | 7  | 6  | 5  | 4  | 3  | 2  | 1  | 0  | X  |
| 1 0     | X                         | X   | 11  | 10  | 9   | 8   | 7  | 6  | 5  | 4  | 3  | 2  | 1  | 0  | X  | X  |
| 1 1     | X                         | 11  | 10  | 9   | 8   | 7   | 6  | 5  | 4  | 3  | 2  | 1  | 0  | X  | X  | X  |

**Figure 61. MRS Value Alignment**

## memory cycles

TMS320C80 external memory cycles are generated by the TC's external memory controller. The controller's state machine generates a sequence of states which define the transition of the memory interface signals. The state sequence is dependent on the cycle timing selected for the memory access being performed as shown in Figure 62. Memory cycles consist of row states and the column pipeline (see Figure 62).



memory cycles (continued)

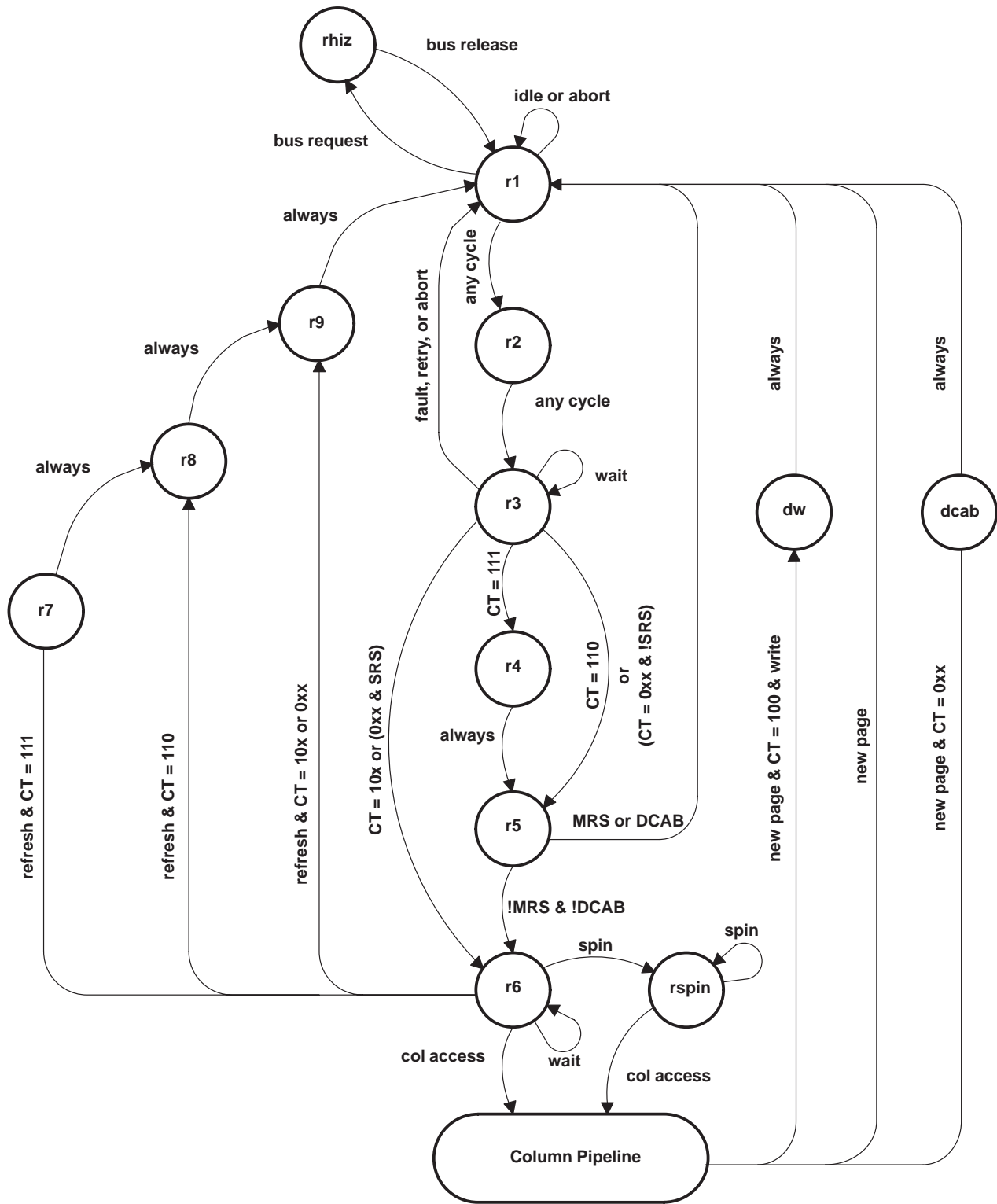

Figure 62. Memory Cycle State Diagram

# TMS320C80 DIGITAL SIGNAL PROCESSOR

SPRS023B – JULY 1994 – REVISED OCTOBER 1997

## row states

The row states make up the row time of each memory access. They occur when each new page access begins. The transition indicators determine the conditions that cause transitions to another state. See Table 35 and Table 36.

**Table 35. Row States**

| STATE | DESCRIPTION  |
|-------|--|
| r1    | Beginning state for all memory accesses. Outputs row address (A[31:0]) and cycle type (STATUS[5:0]) and drives control signals to their inactive state   |
| r2    | Common to all memory accesses. Asserts $\overline{RL}$ and drives $\overline{DDIN}$ according to the data transfer direction. AS[2:0], BS[1:0], CT[2:0], PS[3:0] and $\overline{UTIME}$ inputs are sampled   |
| r3    | Common to all memory accesses. $\overline{DBEN}$ is driven to its active level. For non-SDRAM, $\overline{W}$ , $\overline{TRG/CAS}$ , and DSF are driven to their active levels and for non-SDRAM refreshes, all $\overline{CAS/DQM}$ strobes are activated. $\overline{FAULT}$ , $\overline{READY}$ , and $\overline{RETRY}$ inputs are sampled.                                   |
| r4    | Inserted for 3 cycle/column accesses (CT=111) only. No signal transitions occur. $\overline{RETRY}$ input is sampled.  |
| r5    | Common to SDRAM and 2 or 3 cycle/column accesses (CT=0xx or 11x). $\overline{RAS}$ is driven low. $\overline{W}$ is driven low for DCAB and MRS cycles and $\overline{TRG/CAS}$ is driven low for MRS and SDRAM refresh cycles.  |
| r6    | Common to all memory accesses. For SDRAM cycles, $\overline{RAS}$ , $\overline{TRG/CAS}$ , and $\overline{W}$ are driven high. For non-SDRAM, $\overline{RAS}$ is driven low (if not already) and $\overline{W}$ , $\overline{TRG/CAS}$ , and DSF are driven to their appropriate levels. $\overline{DBEN}$ is driven low and $\overline{READY}$ and $\overline{RETRY}$ are sampled. |
| rspin | Additional state to allow TC column time pipeline to load. No signal transitions occur. $\overline{RETRY}$ is sampled. The rspin state can, on occasion, repeat multiple times.  |
| r7    | Common to 2 and 3 cycle/column refreshes (CT=11x). Processor activity code is output on STATUS[5:0]. $\overline{RETRY}$ input is sampled.  |
| r8    | For 3 cycle/column refreshes only (CT=111). No signal transitions occur. $\overline{RETRY}$ input is sampled.  |
| r9    | Common to all refresh cycles. Processor activity code is output on STATUS[5:0] and $\overline{RETRY}$ input is sampled.  |
| dw    | Occurs for pipelined 1 cycle/column writes only. All $\overline{CAS/DQM}$ strobes are activated.   |
| dcab  | Occurs for SDRAM cycles (CT = 0xx). $\overline{RAS}$ and $\overline{W}$ are activated to perform a DCAB command.   |
| rhiz  | High impedance state. Occurs during host requests and repeats until bus is released by the host  |

**Table 36. State Transition Indicators**

| INDICATOR | DESCRIPTION   |
|-----------|---|
| any cycle | Continuation of current cycle   |
| CT=xxx    | State change occurs for indicated CT[2:0] value (as latched in r2 state)                    |
| abort     | Current cycle aborted by TC in favor of higher priority cycle                               |
| fault     | $\overline{FAULT}$ input sampled low (in r3 state), memory access faulted                   |
| retry     | $\overline{RETRY}$ input sampled low (in r3 state), row-time retry                          |
| wait      | $\overline{READY}$ input sampled low (in r3, r6, or last column state) repeat current state |
| spin      | Internally generated wait state to allow TC pipeline to load                                |
| new page  | The next access requires a page change (new row access).                                    |

## external memory timing examples

The following sections contain descriptions of the 'C80 memory cycles and illustrate the signal transitions for those cycles. Memory cycles may be separated into two basic categories; DRAM-type cycles for use with DRAM-like devices, SRAM, and peripherals, and SDRAM-type cycles for use with SDRAM-like devices.



### DRAM-type cycles

The DRAM-type cycles are page-mode accesses consisting of a row access followed by one or more column accesses. Column accesses may be one, two, or three clock cycles in length with two and three cycle accesses allowing the insertion of wait states to accommodate slow devices. Idle cycles can occur after necessary column accesses have completed or between column accesses due to “bubbles” in the TC data-flow pipeline. The pipeline diagrams in Figure 63 show the pipeline stages for each access type and when the  $\overline{\text{CAS/DQM}}$  signal corresponding to the column access is activated.

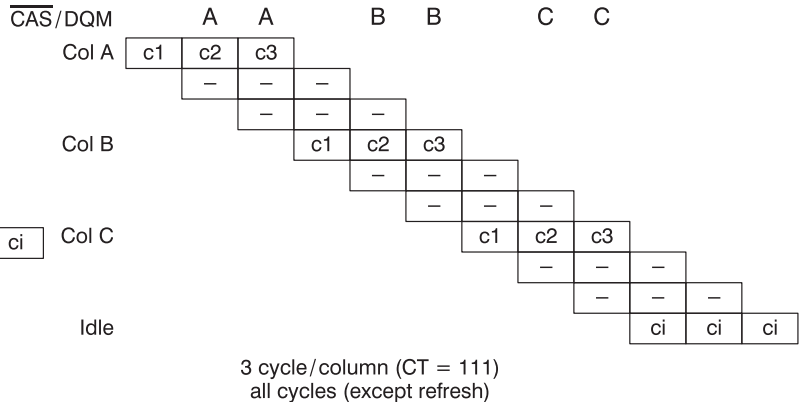
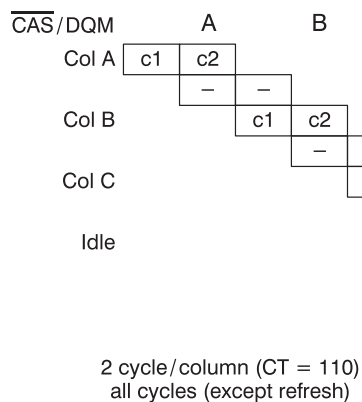
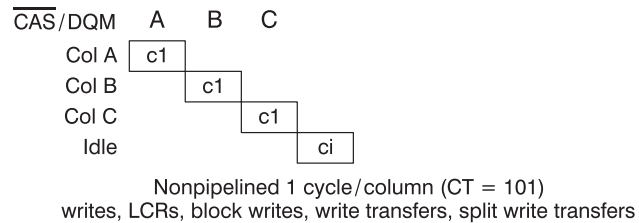
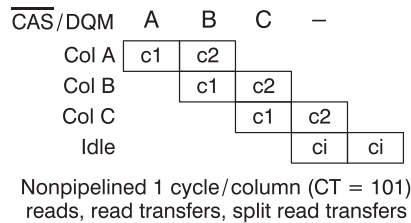
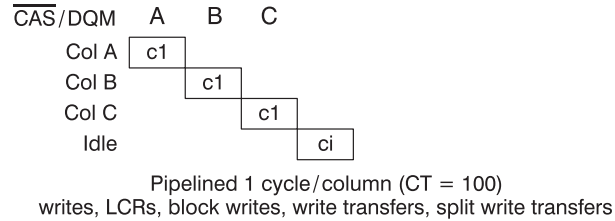
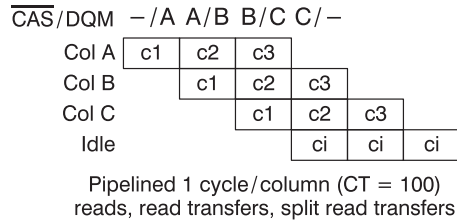

Figure 63. DRAM Cycle Column Pipelines

### read cycles

Read cycles transfer data or instructions from external memory to the 'C80. The cycles can occur as a result of a packet transfer, cache request, or DEA request. During the cycle,  $\overline{\text{W}}$  is held high,  $\overline{\text{TRG/CAS}}$  is driven low after  $\overline{\text{RAS}}$  to enable memory output drivers and  $\overline{\text{DDIN}}$  is low so that data transceivers drive into the 'C80. The TC places D[63:0] in high impedance allowing it to be driven by the memory and latches input data during the appropriate column state. The TC always reads 64 bits and extracts and aligns the appropriate bytes. Invalid bytes for bus sizes of less than 64 bits are discarded. During peripheral device packet transfers,  $\overline{\text{DBEN}}$  remains high. Read cycles are shown in Figure 64 through Figure 67.

# TMS320C80 DIGITAL SIGNAL PROCESSOR

SPRS023B – JULY 1994 – REVISED OCTOBER 1997

## read cycles (continued)

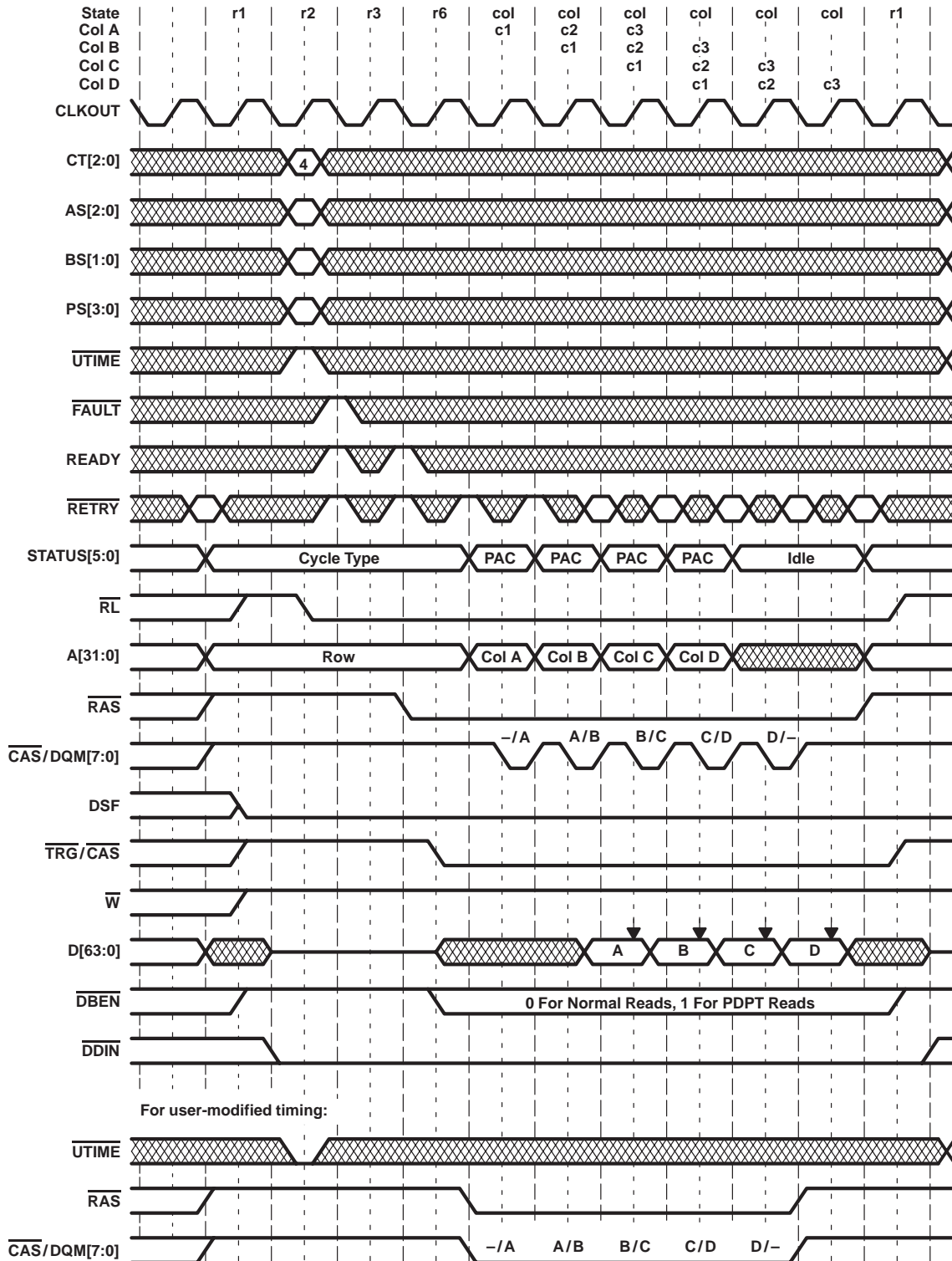

Figure 64. Pipelined 1 Cycle/Column Read-Cycle Timing



read cycles (continued)

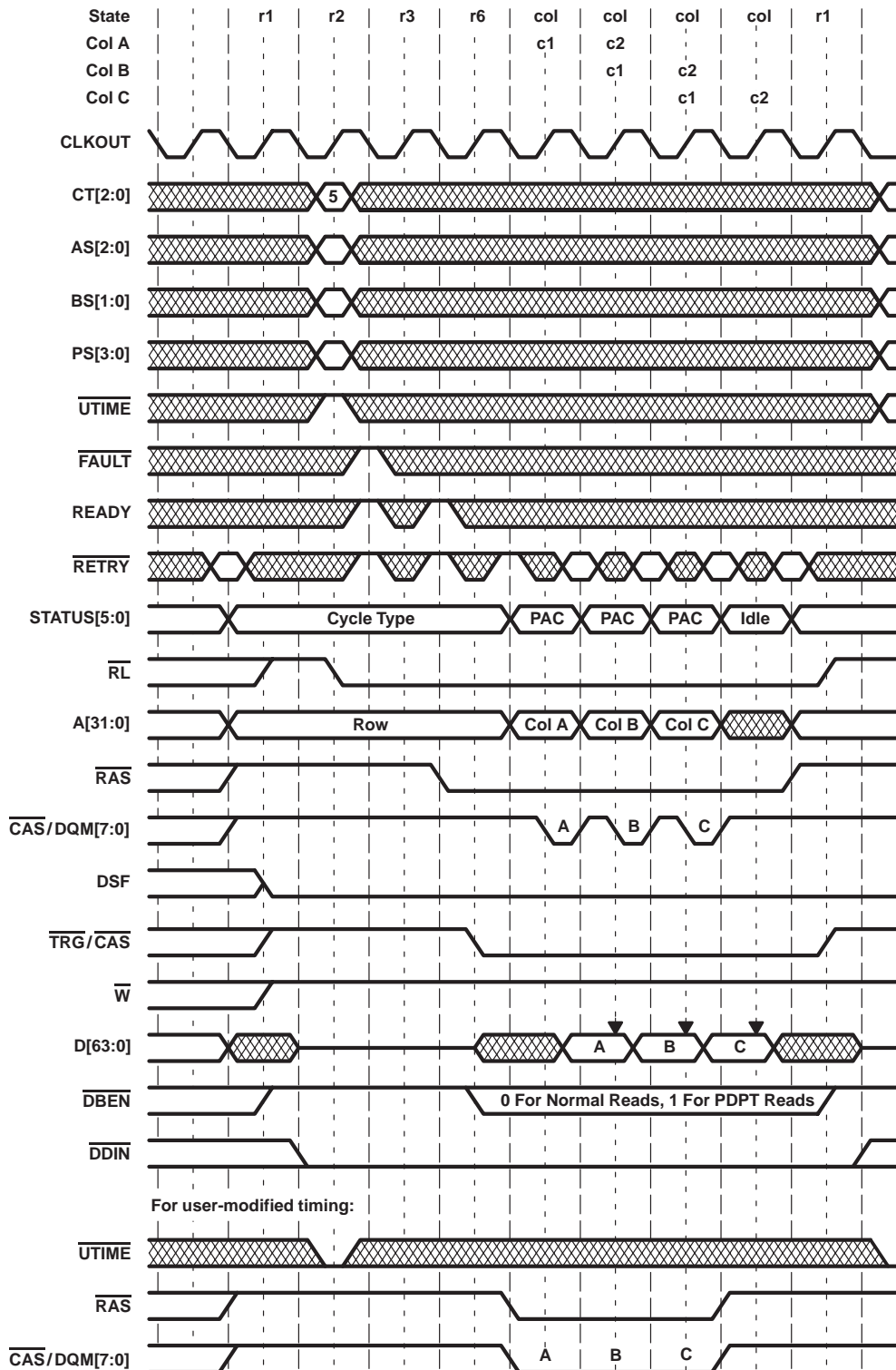
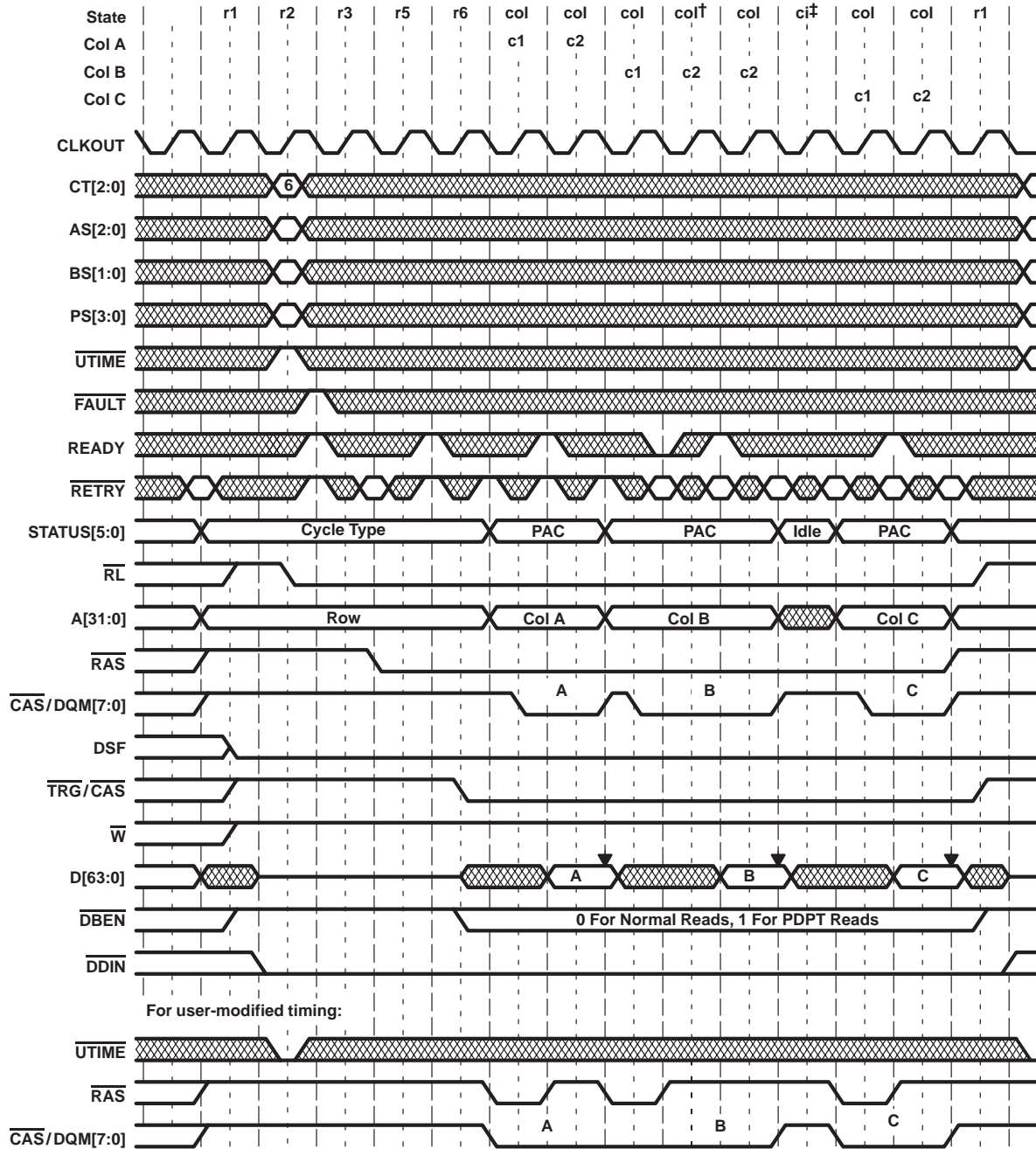

Figure 65. Nonpipelined 1 Cycle/Column Read-Cycle Timing

# TMS320C80 DIGITAL SIGNAL PROCESSOR

SPRS023B – JULY 1994 – REVISED OCTOBER 1997

## read cycles (continued)



† Wait state inserted by external logic (example)

‡ Internally generated pipeline bubble (example)

Figure 66. 2 Cycles/Column Read-Cycle Timing

read cycles (continued)

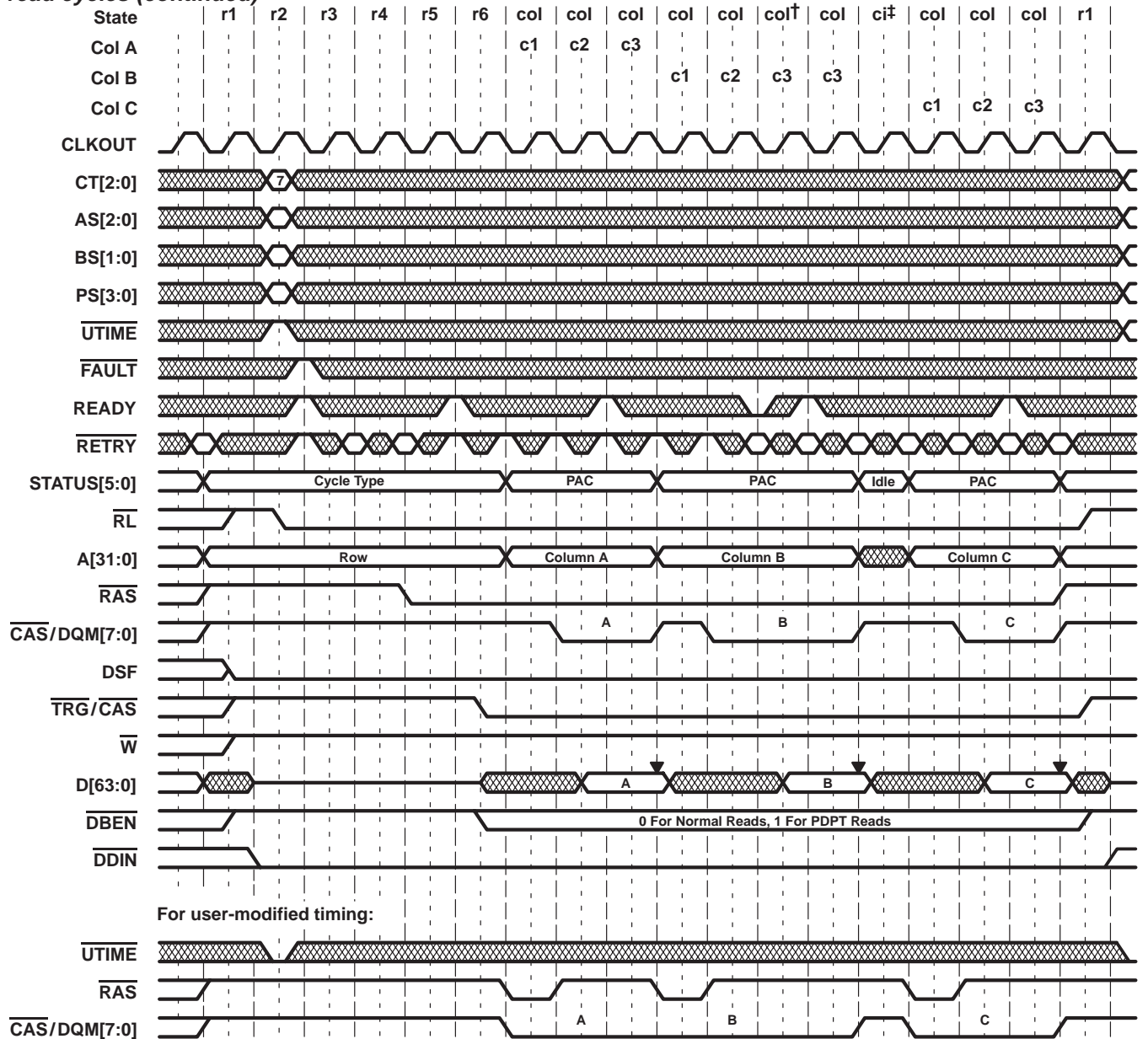

† Wait state inserted by external logic (example)  
‡ Internally generated pipeline bubble (example)

Figure 67. 3 Cycles/Column Read-Cycle Timing

write cycles

Write cycles transfer data from the 'C80 to external memory. These cycles can occur as a result of a packet transfer, a DEA request, or an MP data cache write-back. During the cycle TRG/CAS is held high,  $\overline{W}$  is driven low after the fall of RAS to enable early-write cycles, and DDIN is high so that data transceivers drive toward memory. The TC drives data out on D[63:0] and indicates valid bytes by activating the appropriate CAS/DQM strobes. During peripheral device packet transfers, DBEN remains high and D[63:0] is placed in high impedance so that the peripheral device can drive data into the memory. Write cycles are shown in Figure 68 through Figure 71.

# TMS320C80 DIGITAL SIGNAL PROCESSOR

SPRS023B – JULY 1994 – REVISED OCTOBER 1997

## write cycles (continued)

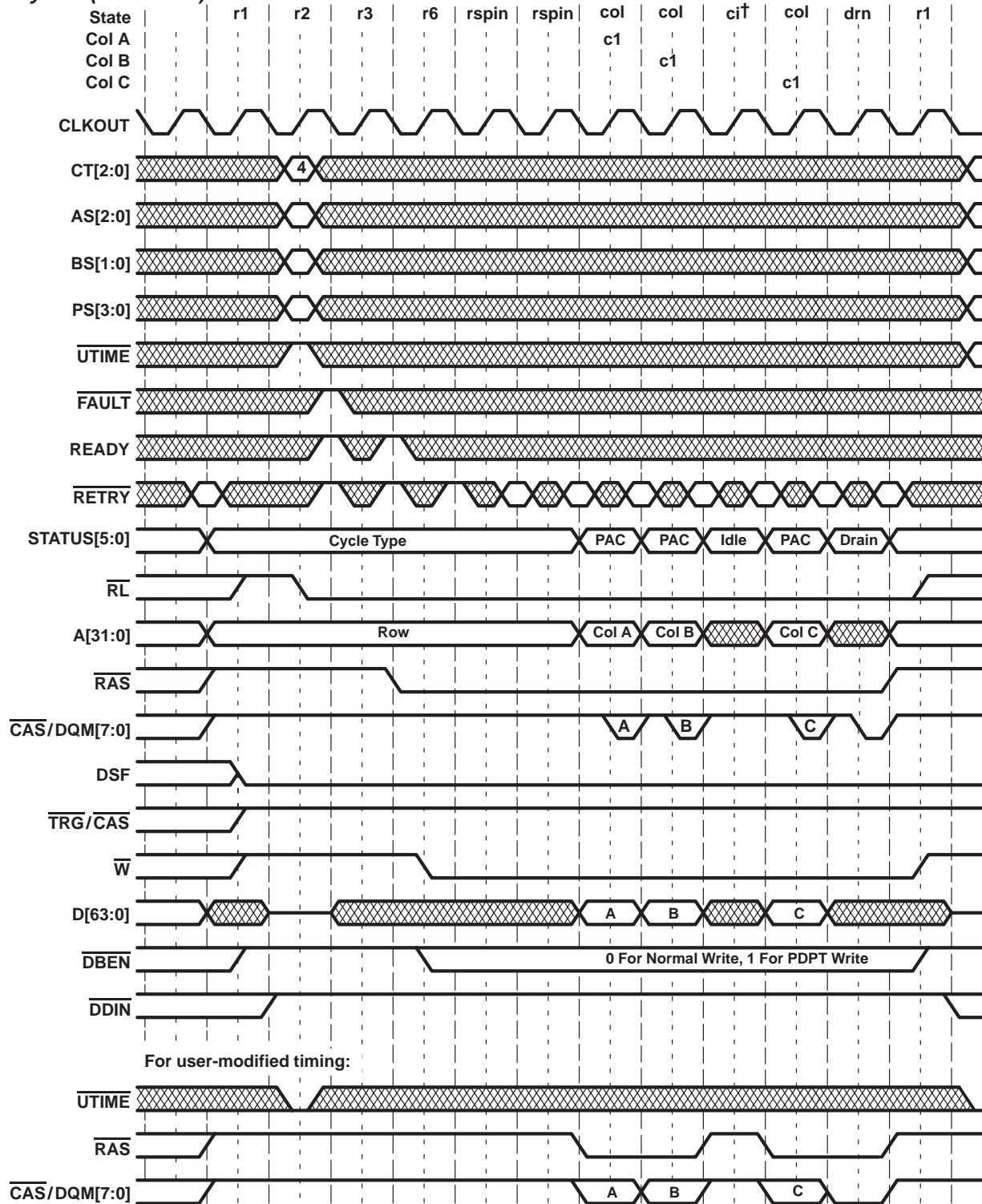
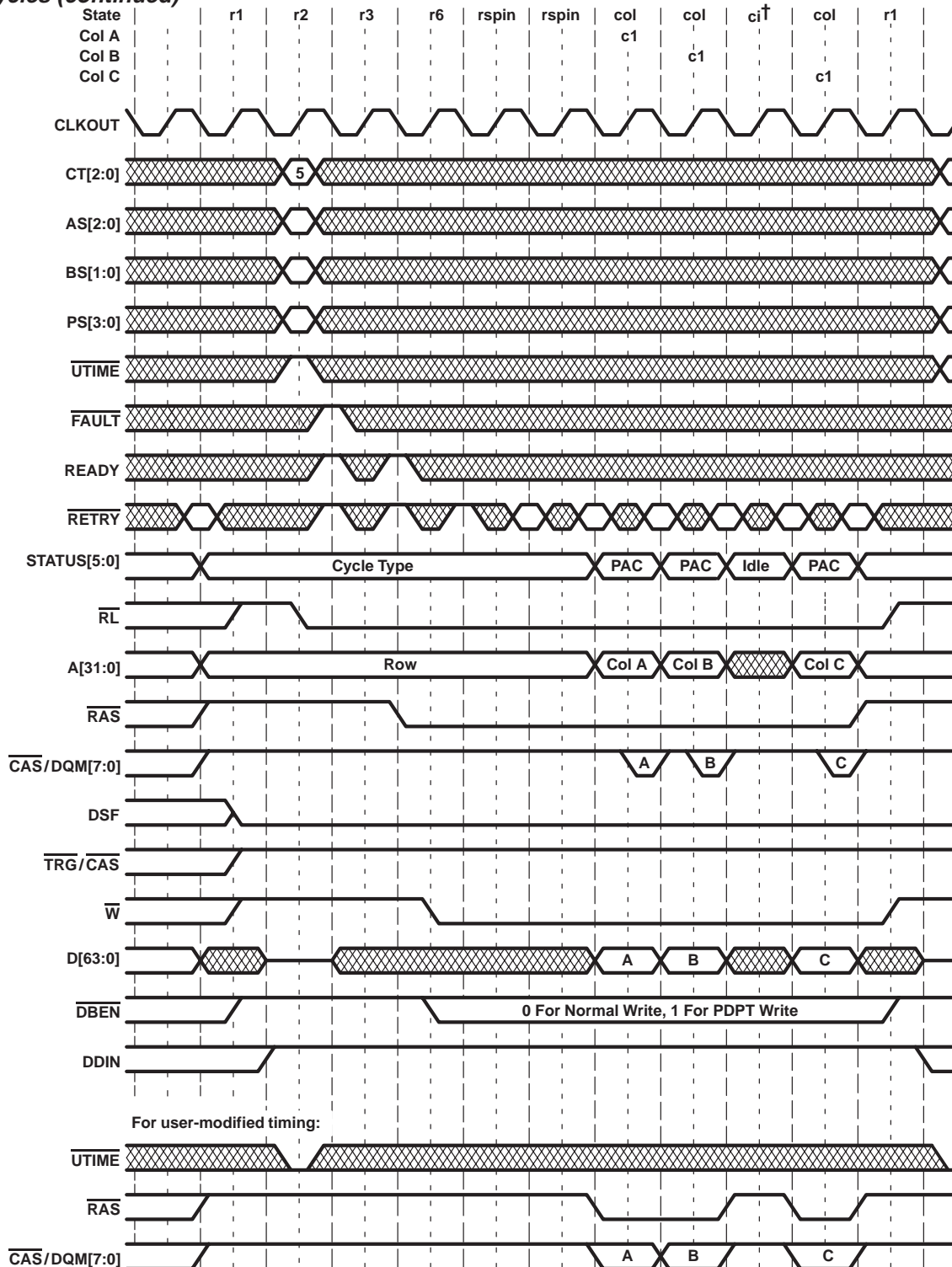

Figure 68. Pipelined 1 Cycle/Column Write-Cycle Timing

write cycles (continued)



† Internally generated pipeline bubble (example)

Figure 69. Nonpipelined 1 Cycle/Column Write-Cycle Timing

# TMS320C80 DIGITAL SIGNAL PROCESSOR

SPRS023B – JULY 1994 – REVISED OCTOBER 1997

## write cycles (continued)

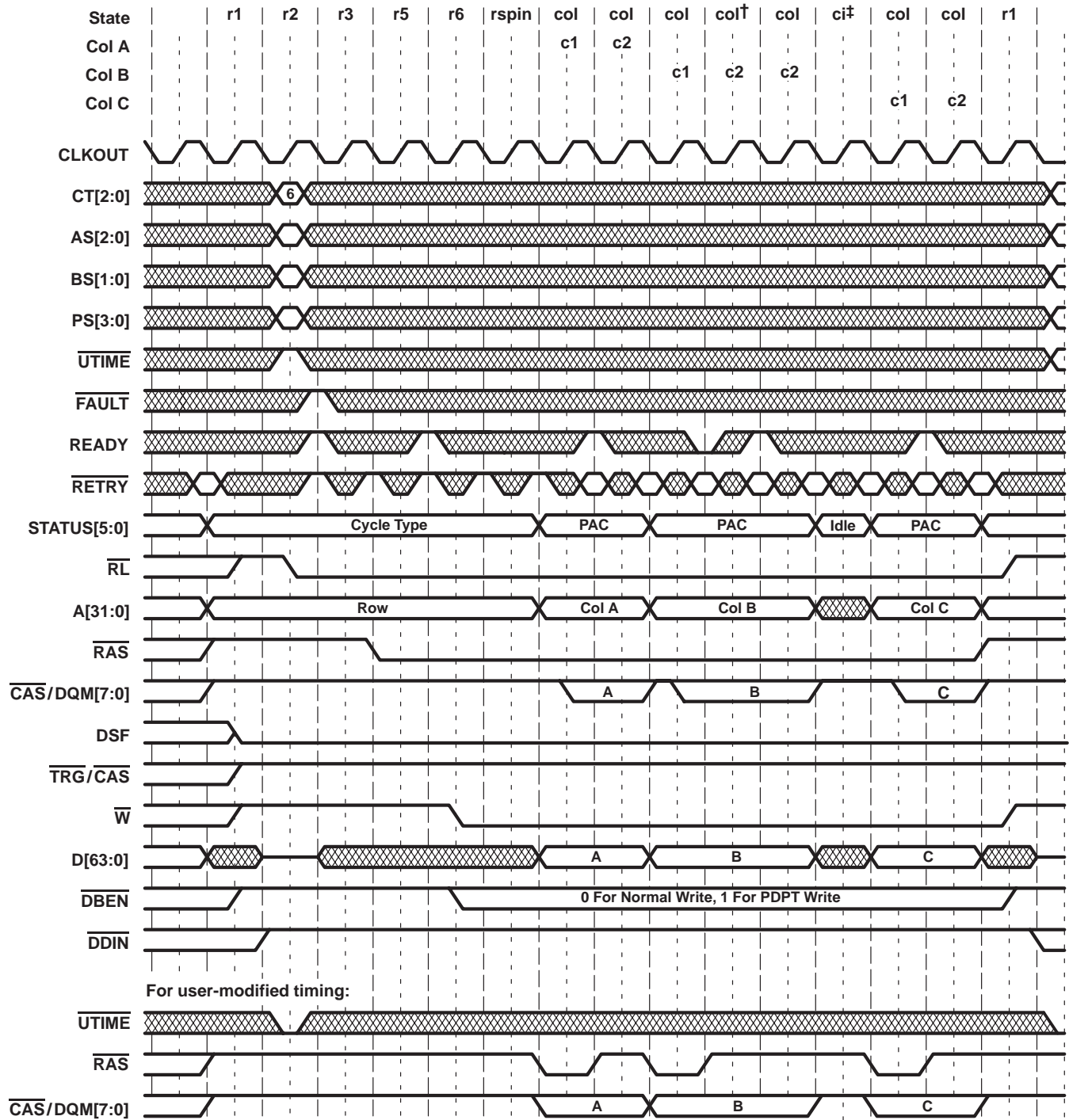

† Wait state inserted by external logic (example)  
‡ Internally generated pipeline bubble (example)

Figure 70. 2 Cycles/Column Write-Cycle Timing

write cycles (continued)

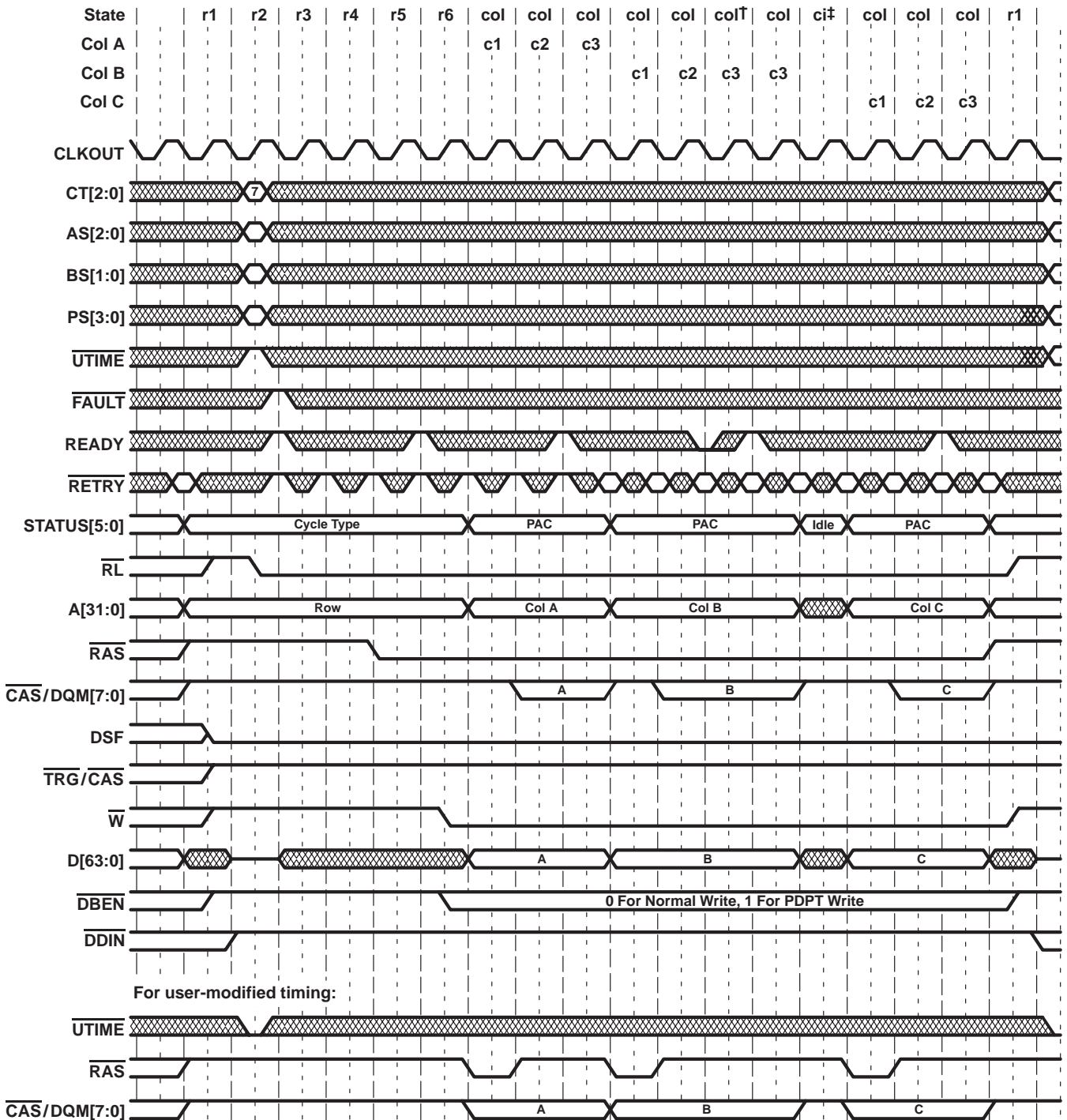

† Wait state inserted by external logic (example)  
‡ Internally generated pipeline bubble (example)

Figure 71. 3 Cycles/Column Write-Cycle Timing

# TMS320C80

## DIGITAL SIGNAL PROCESSOR

SPRS023B – JULY 1994 – REVISED OCTOBER 1997

---

### *load-color-register cycles*

Load-color-register (LCR) cycles are used to load a VRAM's color register prior to performing a block write. LCR cycles are supported only on 64-bit data buses. An LCR cycle closely resembles a normal write cycle because it writes into a VRAM. The difference is that the DSF output is high at both the fall of  $\overline{RAS}$  and the fall of  $\overline{CAS}/DQM$ . Also, because the VRAM color register is a single location, only one column access occurs.

The row address that is output by the TC is used for bank decode only. Normally all VRAM banks should be selected during an LCR cycle because another LCR cycle will not occur when a block-write memory page change occurs. The column address that is output during an LCR is likewise irrelevant because the VRAM color register is the only location written. All  $\overline{CAS}/DQM$  strobes are active during an LCR cycle.

The  $\overline{RETRY}$  input is sampled during LCR column states and must be valid high or low. Asserting  $\overline{RETRY}$  at column time has no effect, however, because only one column access is performed.

If the BS[1:0] inputs indicate that the addressed memory supports only simulated block writes, the LCR cycle will be changed into a normal write cycle at the start of the simulated block write. Load color register cycles timing is shown in Figure 72 through Figure 75.



load-color-register cycles (continued)

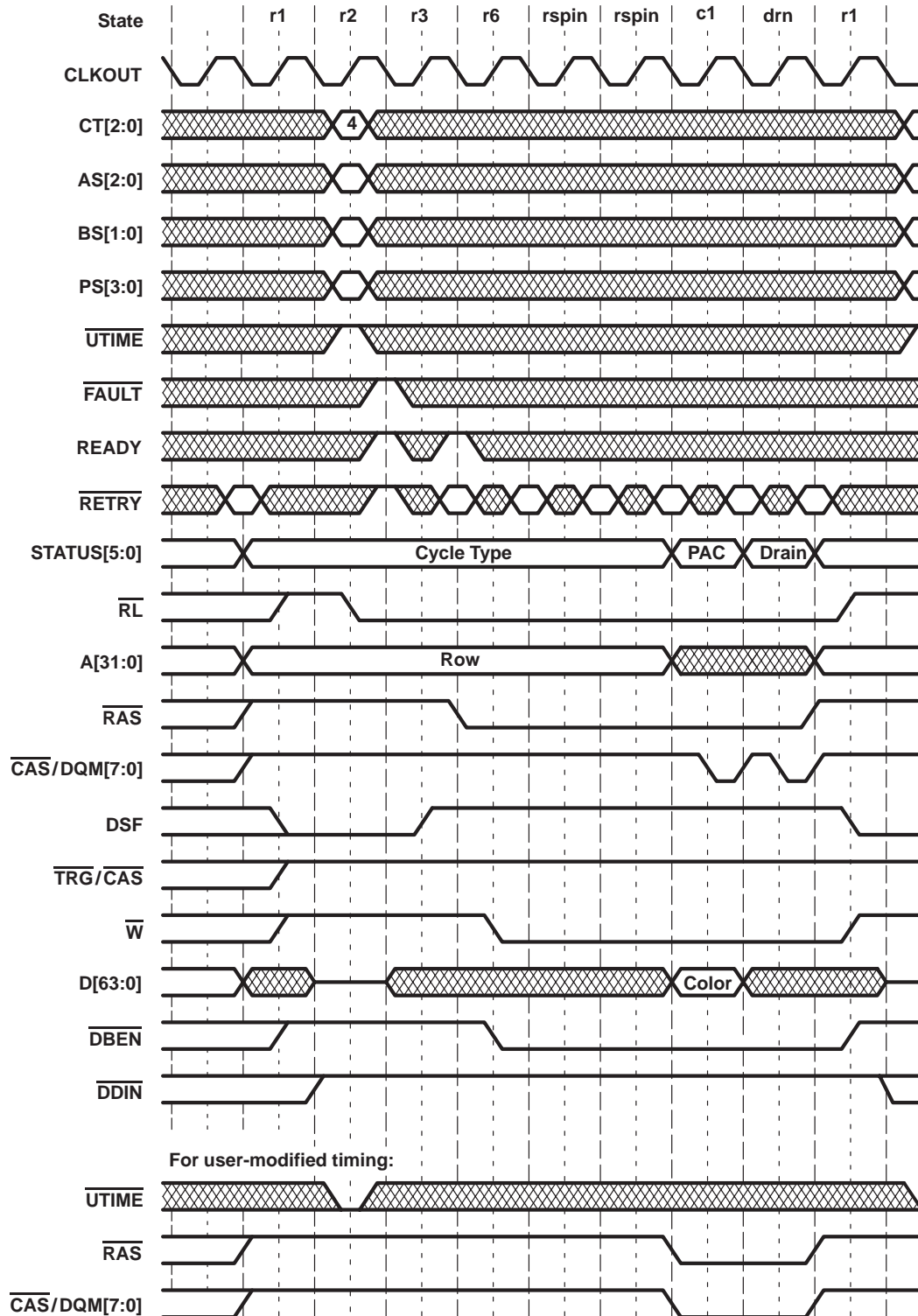

Figure 72. Pipelined 1 Cycle/Column Load-Color-Register-Cycle Timing

# TMS320C80 DIGITAL SIGNAL PROCESSOR

SPRS023B – JULY 1994 – REVISED OCTOBER 1997

## load-color-register cycles (continued)

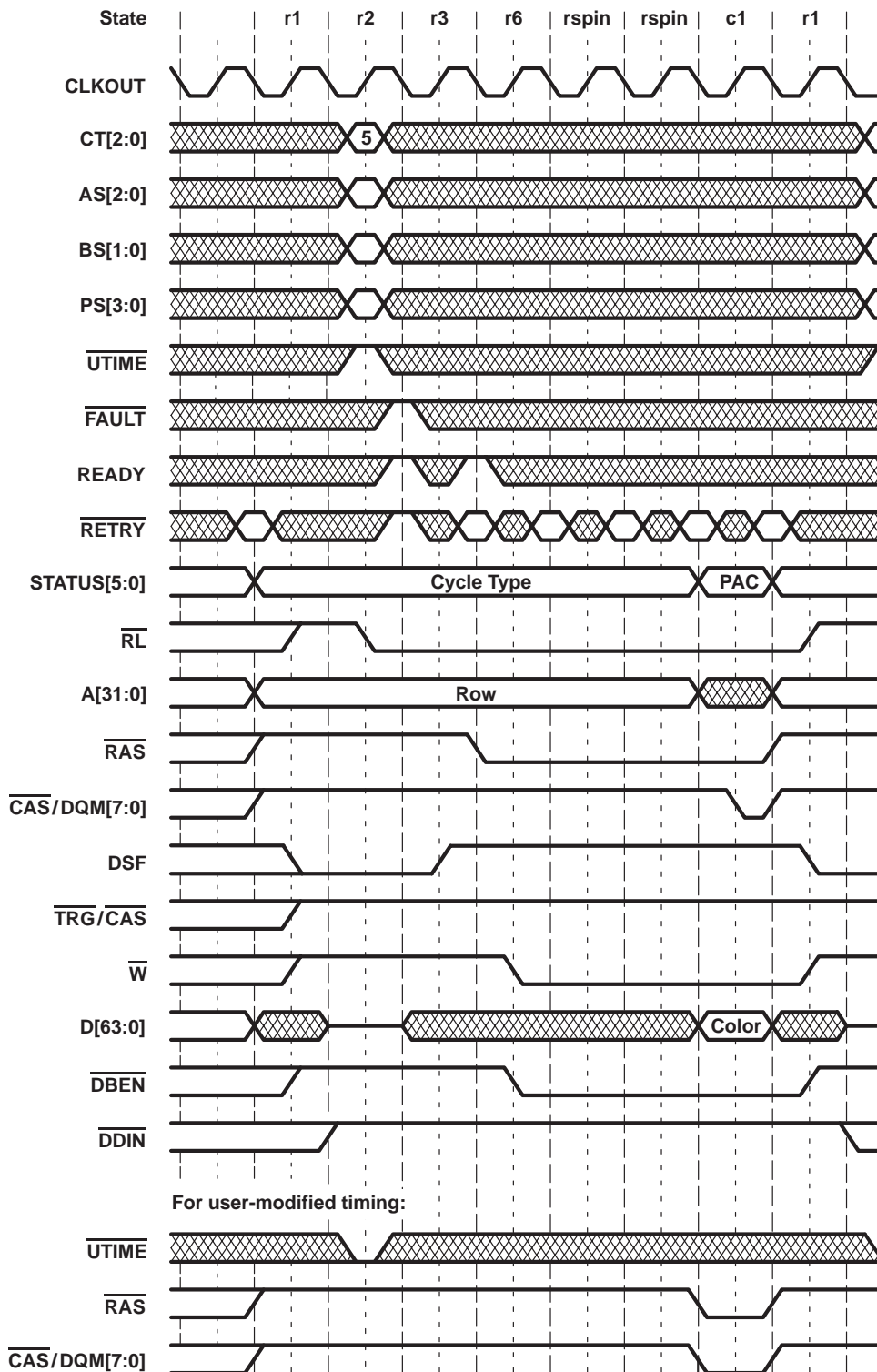

Figure 73. Nonpipelined 1 Cycle/Column Load-Color-Register-Cycle Timing

load-color-register cycles (continued)

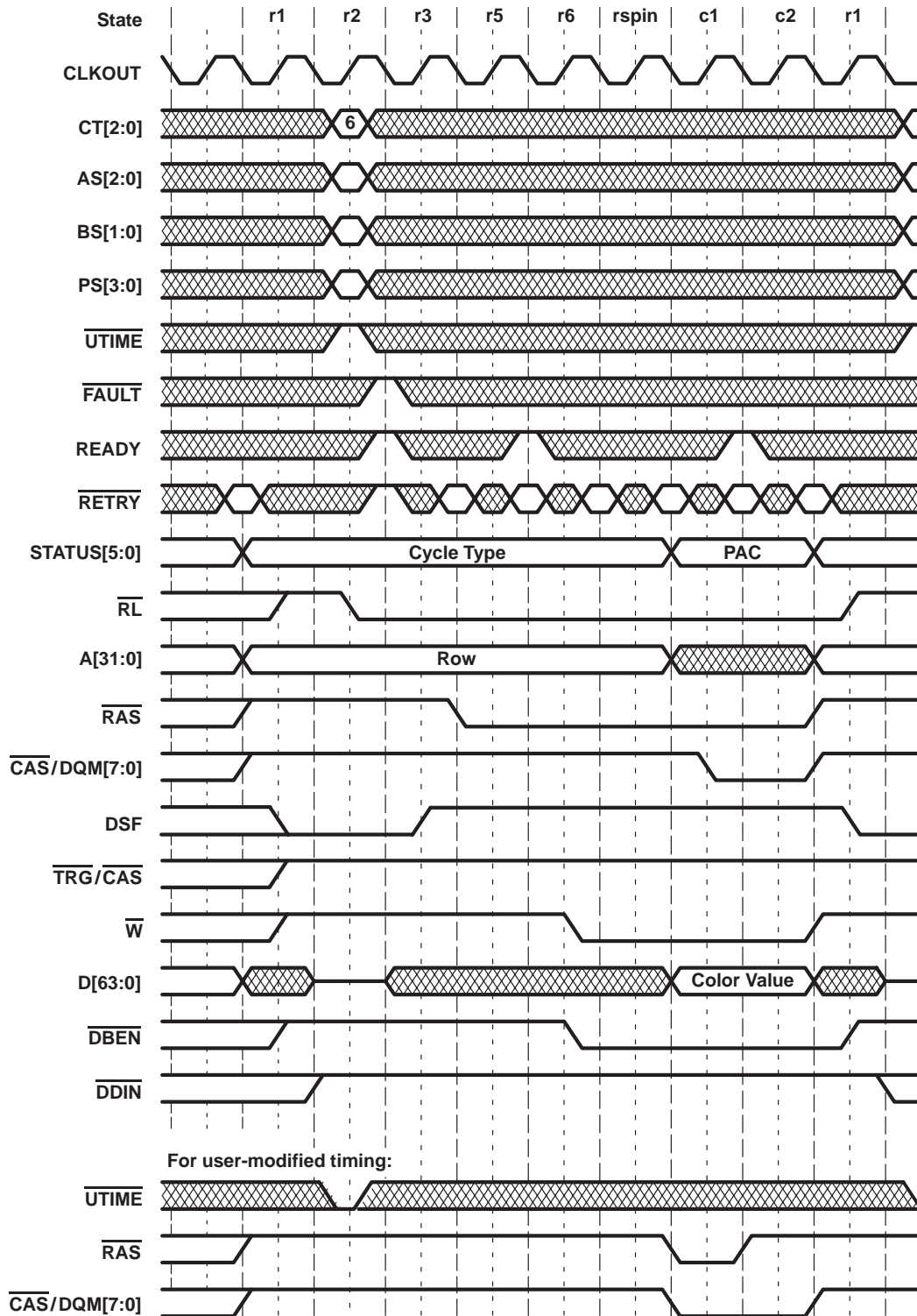

Figure 74. 2 Cycles/Column Load-Color-Register-Cycle Timing

# TMS320C80 DIGITAL SIGNAL PROCESSOR

SPRS023B – JULY 1994 – REVISED OCTOBER 1997

## load-color-register cycles (continued)

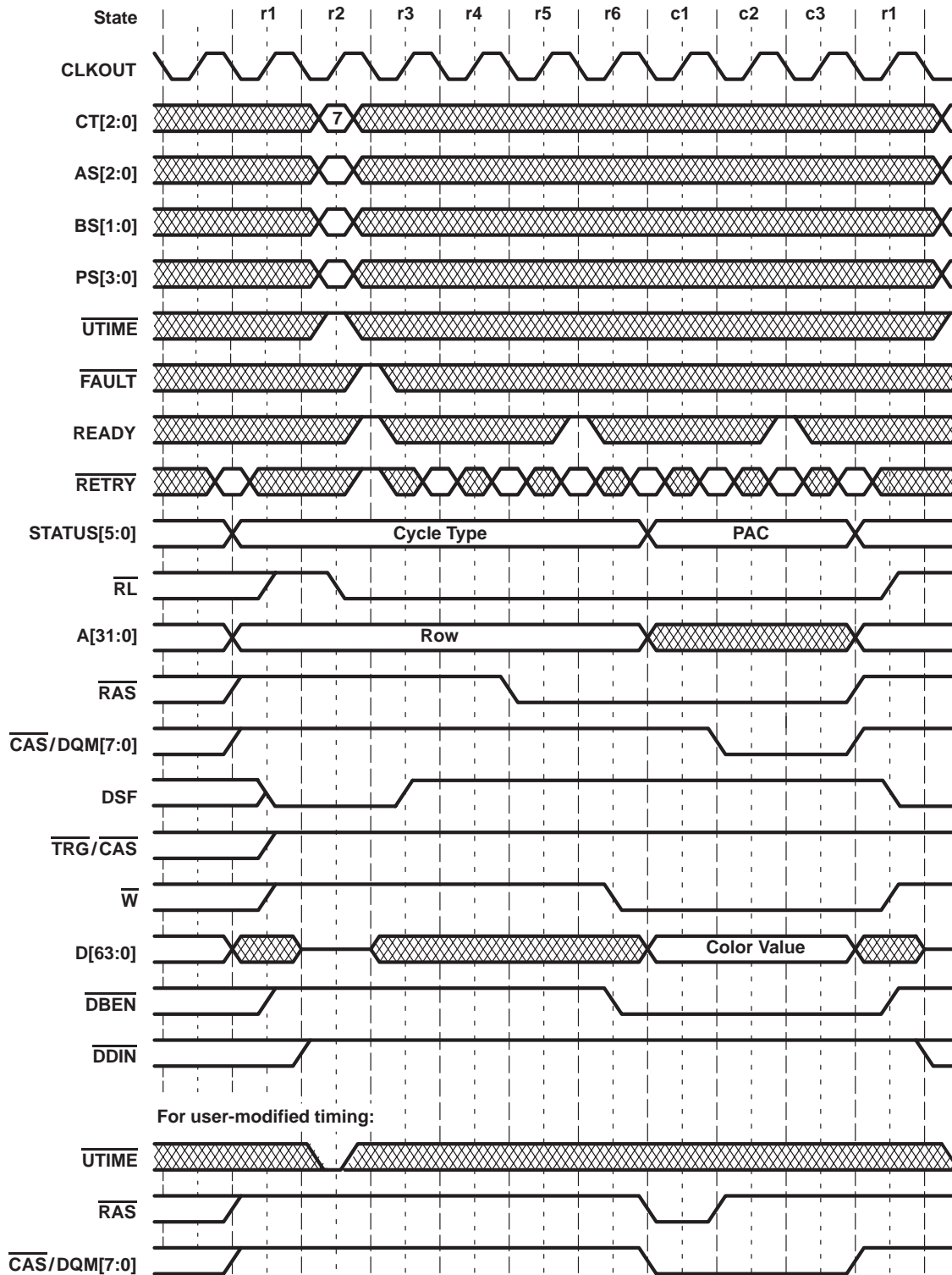

Figure 75. 3 Cycles/Column Load-Color-Register-Cycle Timing



POST OFFICE BOX 1443 • HOUSTON, TEXAS 77251-1443

### ***block-write cycles***

Block-write cycles cause the data stored in the VRAM color registers to be written to the memory locations enabled by the appropriate data bits output on the D[63:0] bus. This allows up to a total of 64 bytes (depending on the type of block write being used) to be written in a single-column access. This cycle is identical to a standard write cycle with the following exceptions:

- DSF is active (high) at the fall of  $\overline{\text{CAS}}$ , enabling the block-write function within the VRAMs.
- Only 64-bit bus sizes are supported during block write; therefore, BS[1:0] inputs are used to indicate the type of block write that is supported by the addressed VRAMs, rather than the bus size.
- The two or three LSBs (depending on the type of block write) of the column address are ignored by the VRAMs because these column locations are specified by the data inputs.
- The values output by the TC on D[63:0] represent the column locations to be written to, using the color-register value. Depending on the type of block write supported by the VRAM, all of the data bits are not necessarily used by the VRAMs.
- Block writes always begin with a row access. Upon completion of a block write, the memory interface returns to state r1 to await the next access.

See Figure 76 through Figure 79 for block-write cycle timing.

# TMS320C80 DIGITAL SIGNAL PROCESSOR

SPRS023B – JULY 1994 – REVISED OCTOBER 1997

## block-write cycles (continued)

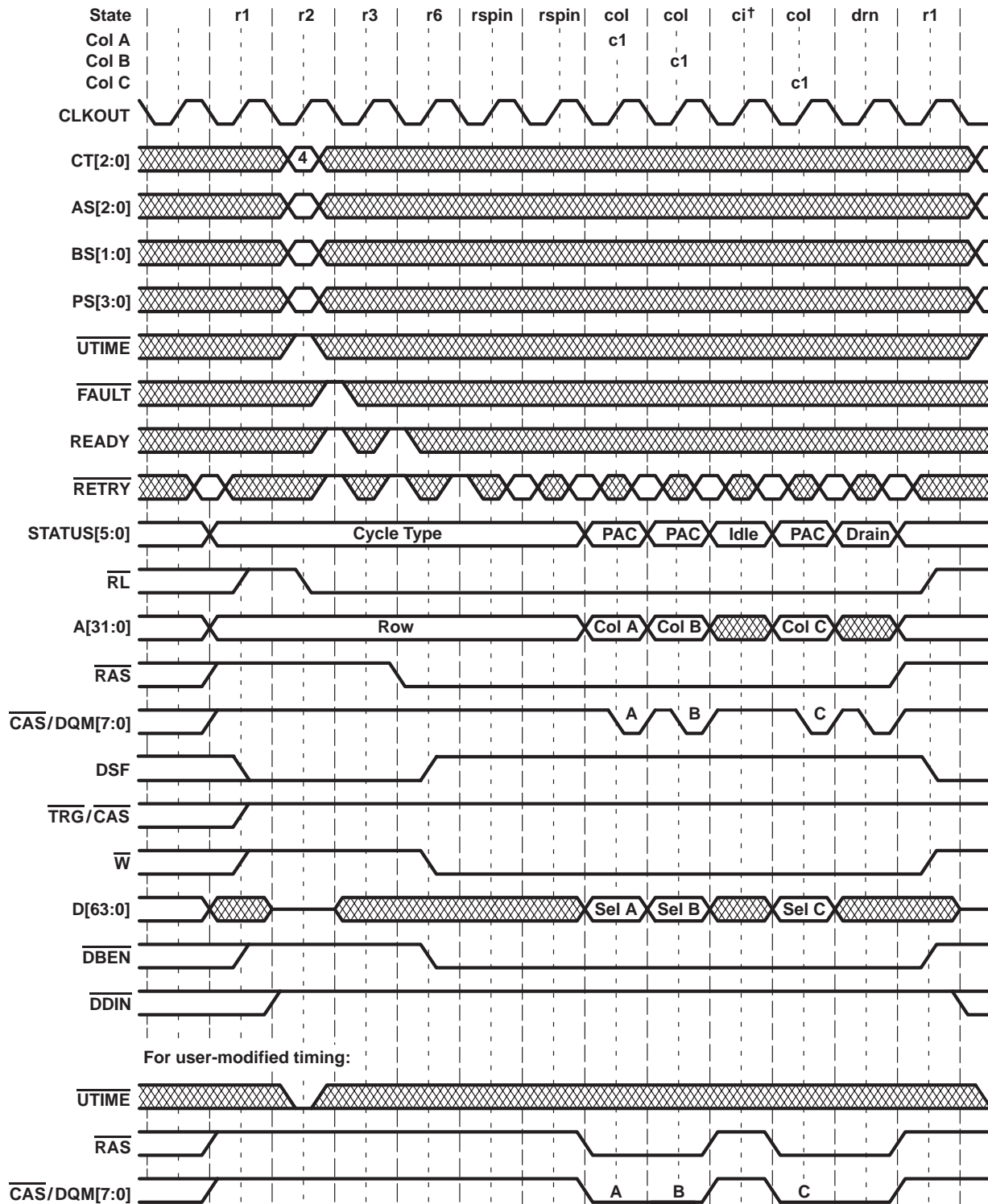

† Internally generated pipeline bubble (example)

Figure 76. Pipelined 1 Cycle/Column Block-Write-Cycle Timing



POST OFFICE BOX 1443 • HOUSTON, TEXAS 77251-1443

block-write cycles (continued)

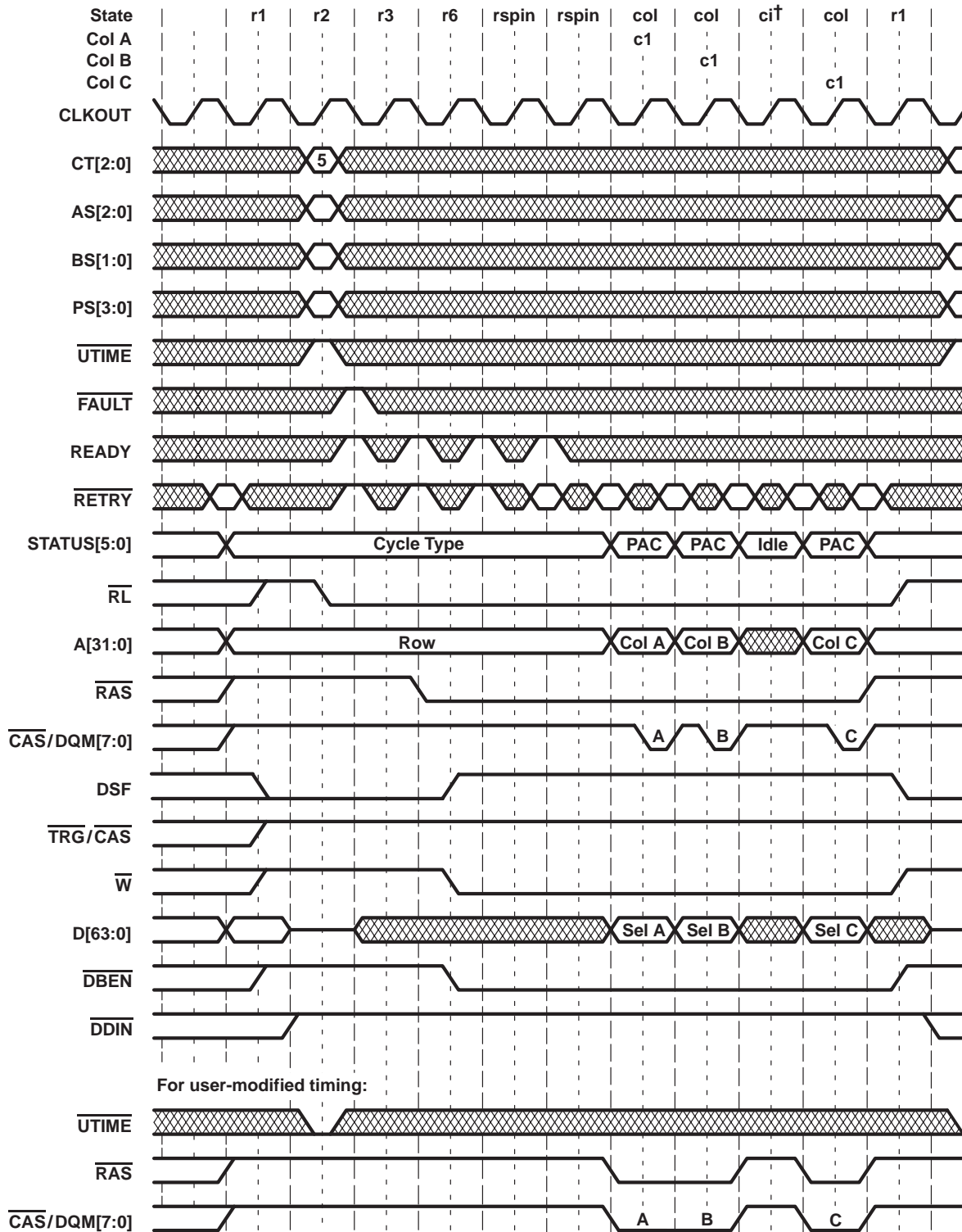

† Internally generated pipeline bubble (example)

Figure 77. Nonpipelined 1 Cycle/Column Block-Write-Cycle Timing

# TMS320C80 DIGITAL SIGNAL PROCESSOR

SPRS023B – JULY 1994 – REVISED OCTOBER 1997

## block-write cycles (continued)

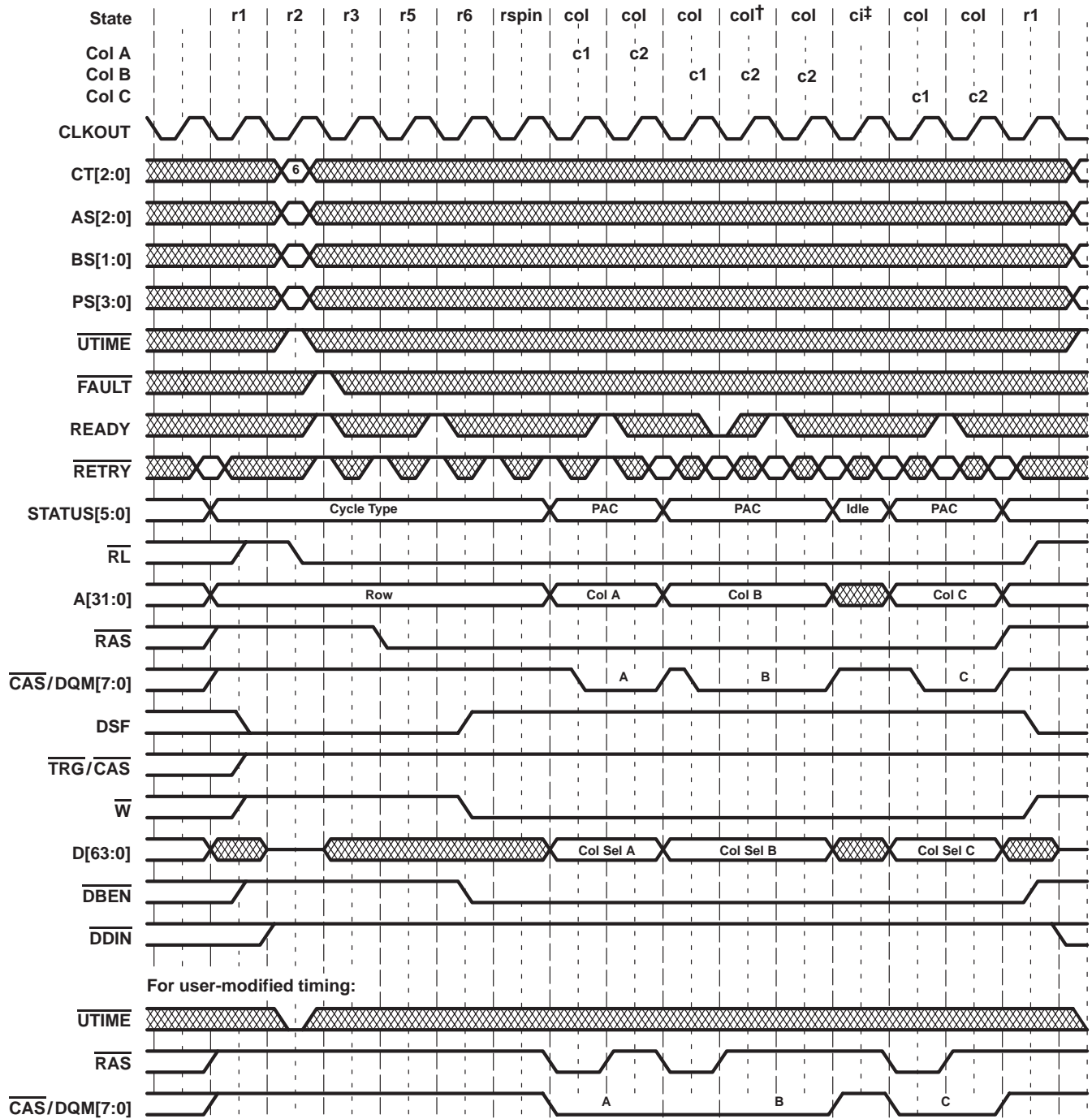

† Wait state inserted by external logic (example)

‡ Internally generated pipeline bubble (example)

Figure 78. 2 Cycles/Column Block-Write-Cycle Timing



block-write cycles (continued)

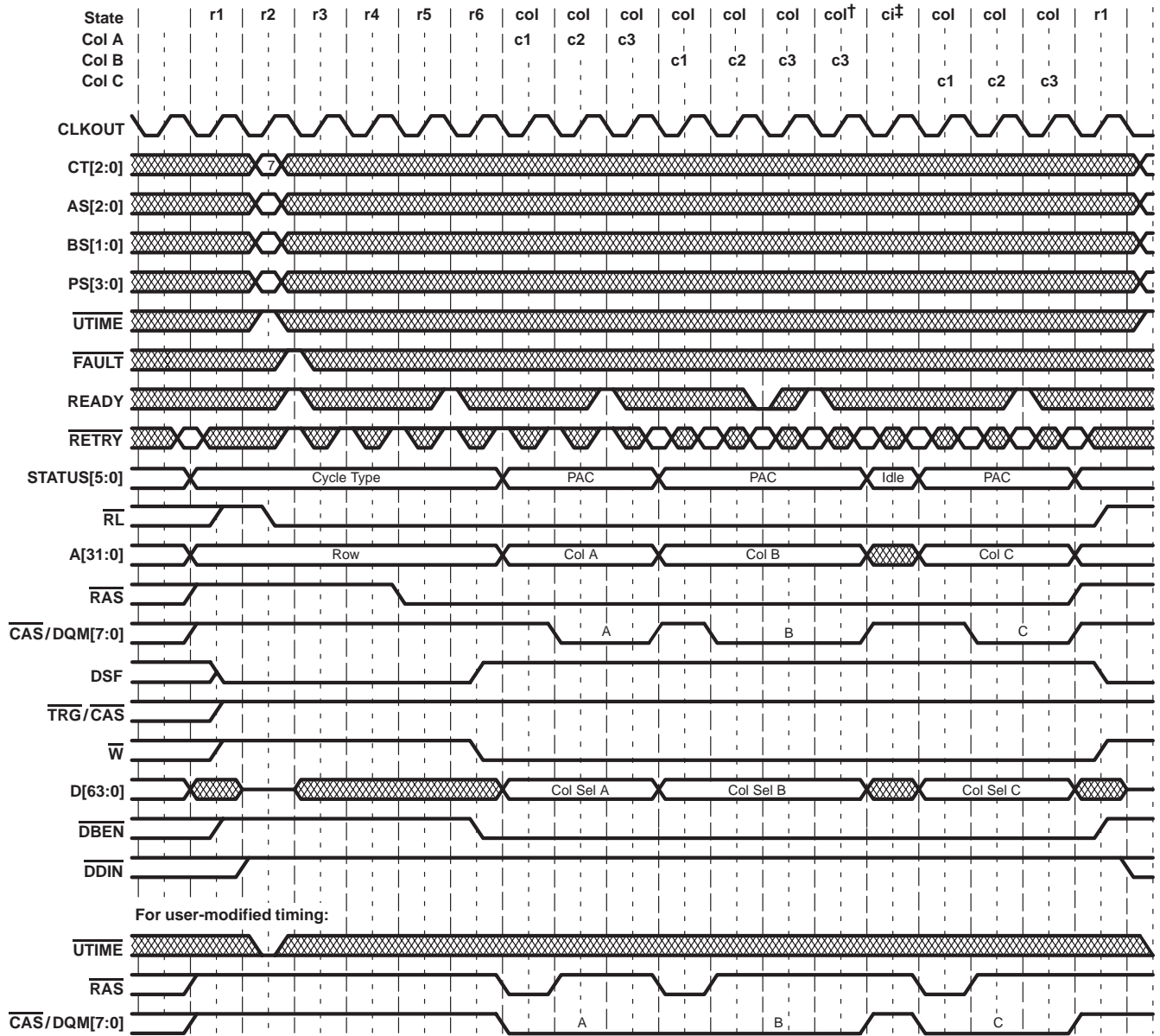

† Wait state inserted by external logic (example)  
‡ Internally generated pipeline bubble (example)

Figure 79. 3 Cycles/Column Block-Write-Cycle Timing

# TMS320C80

## DIGITAL SIGNAL PROCESSOR

SPRS023B – JULY 1994 – REVISED OCTOBER 1997

---

### *transfer cycles*

Read-transfer (memory-to-register) cycles transfer a row from the VRAM memory array into the VRAM shift register (SAM). This causes the entire SAM (both halves of the split SAM) to be loaded with the array data.

Split-register read-transfer (memory-to-split-register) cycles also transfer data from a row in the memory array to the SAM. However, these transfers cause only half of the SAM to be written. Split-register read transfers allow the inactive half of the SAM to be loaded with the new data while the other active half continues to shift data in or out.

Write-transfer (register-to-memory) cycles transfer data from the SAM into a row of the VRAM array. This transfer causes the entire SAM (both halves of the split SAM) to be written into the array.

Split-register write-transfer (split-register-to-memory) cycles also transfer data from the SAM to a row in the memory array. However, these transfers write only half of the SAM into the array. Split-register write transfers allow the inactive half of the SAM to be transferred into memory while the other (active) half continues to shift serial data in or out.

Read and split-read transfers resemble a standard read cycle. Write and split-write transfers resemble a standard write cycle. The  $\overline{\text{TRG}}/\overline{\text{CAS}}$  output is driven low prior to the fall of  $\overline{\text{RAS}}$  to indicate a transfer cycle. Only a single column access is performed so  $\overline{\text{RETRY}}$ , while required to be at a valid level, has no effect if asserted at column time. The value output on A[31:0] at column time represents the SAM tap point (see Figure 80 through Figure 86 for transfer cycle timing).



transfer cycles (continued)

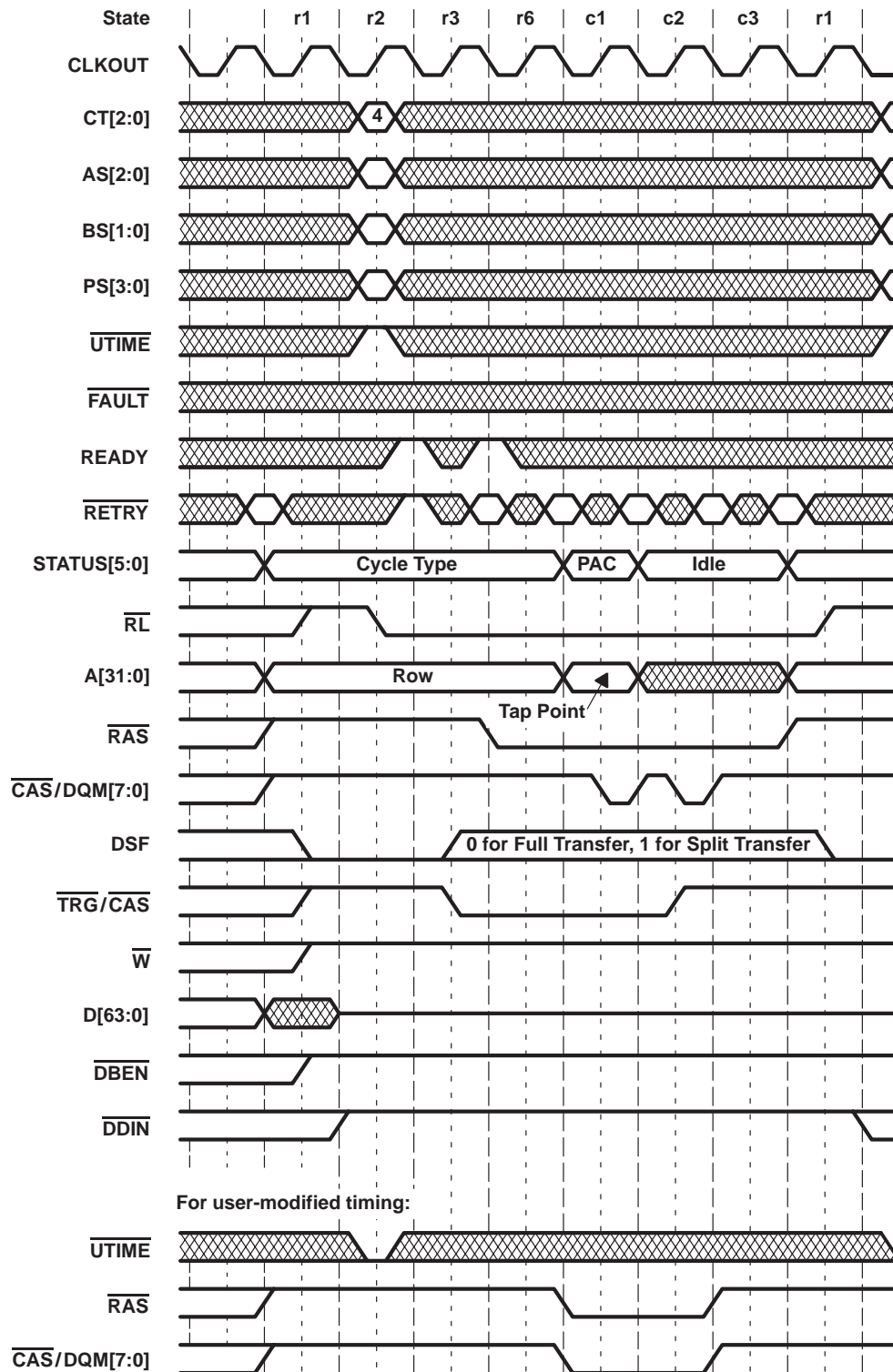

Figure 80. Pipelined 1 Cycle/Column Read-Transfer and Split-Register Read-Transfer-Cycle Timing

# TMS320C80 DIGITAL SIGNAL PROCESSOR

SPRS023B – JULY 1994 – REVISED OCTOBER 1997

## transfer cycles (continued)

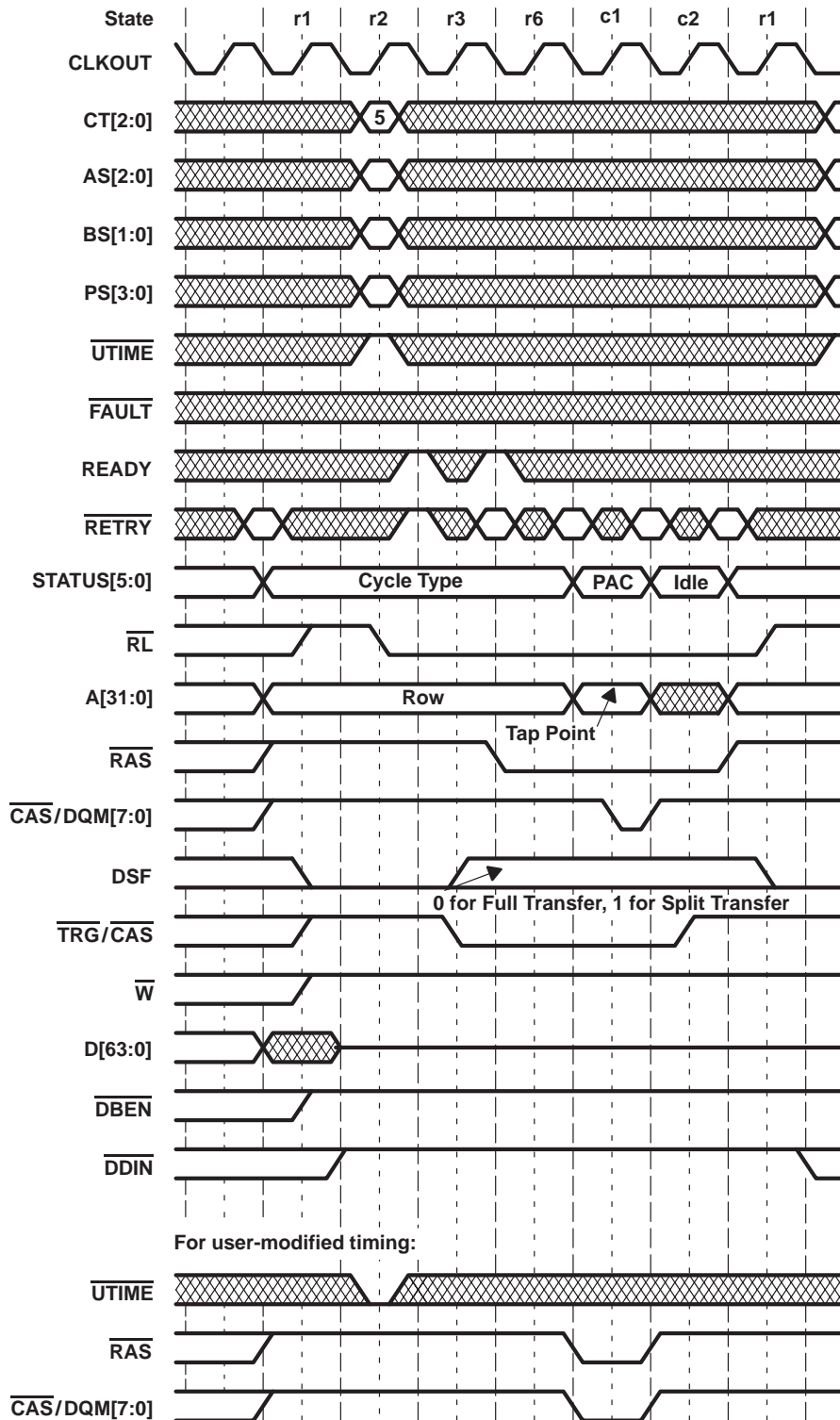

Figure 81. Nonpipelined 1 Cycle/Column Read-Transfer and Split-Register Read-Transfer-Cycle Timing



transfer cycles (continued)

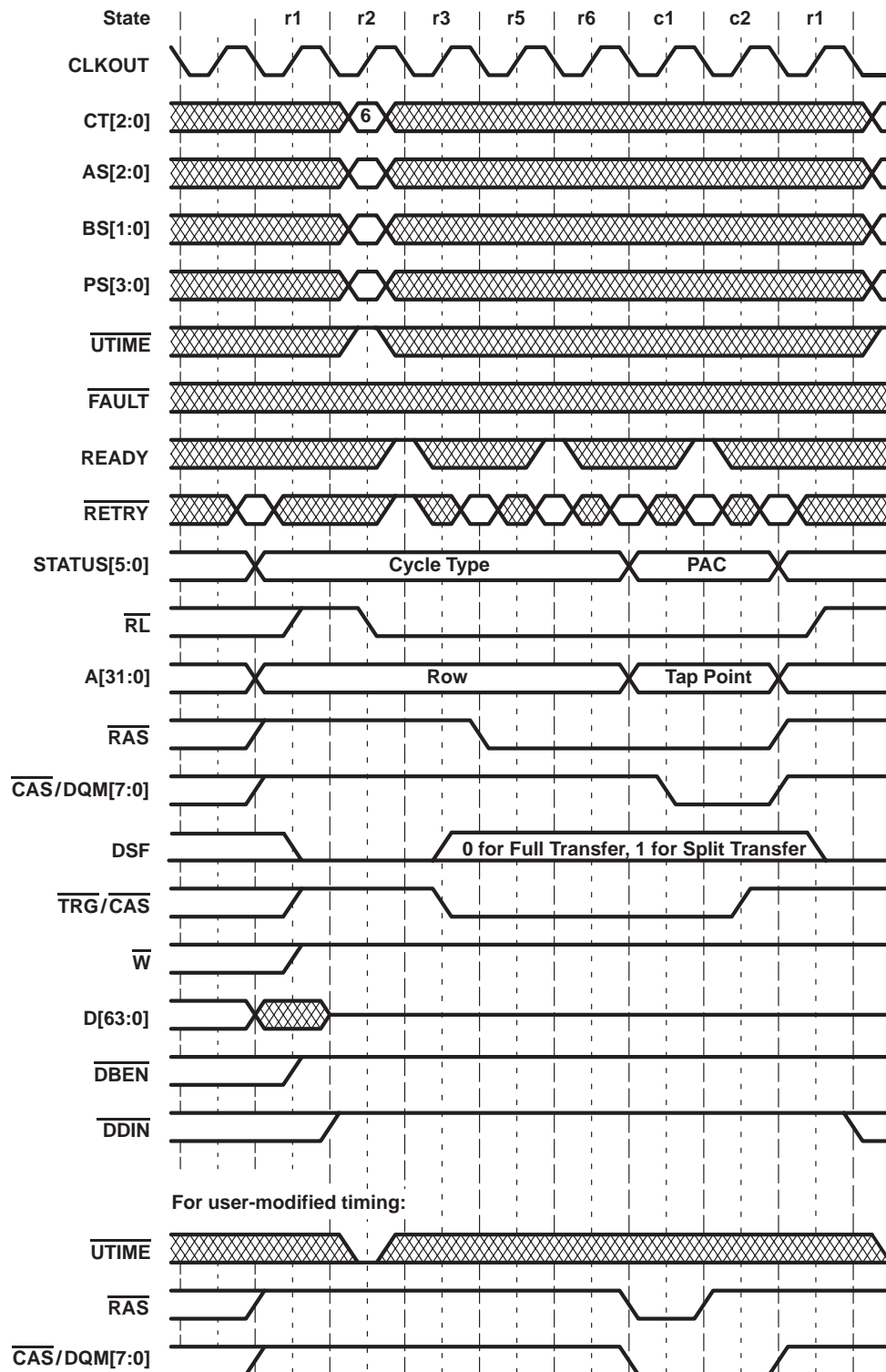

Figure 82. 2 Cycles/Column Read-Transfer and Split-Register Read-Transfer-Cycle Timing

# TMS320C80 DIGITAL SIGNAL PROCESSOR

SPRS023B – JULY 1994 – REVISED OCTOBER 1997

## transfer cycles (continued)

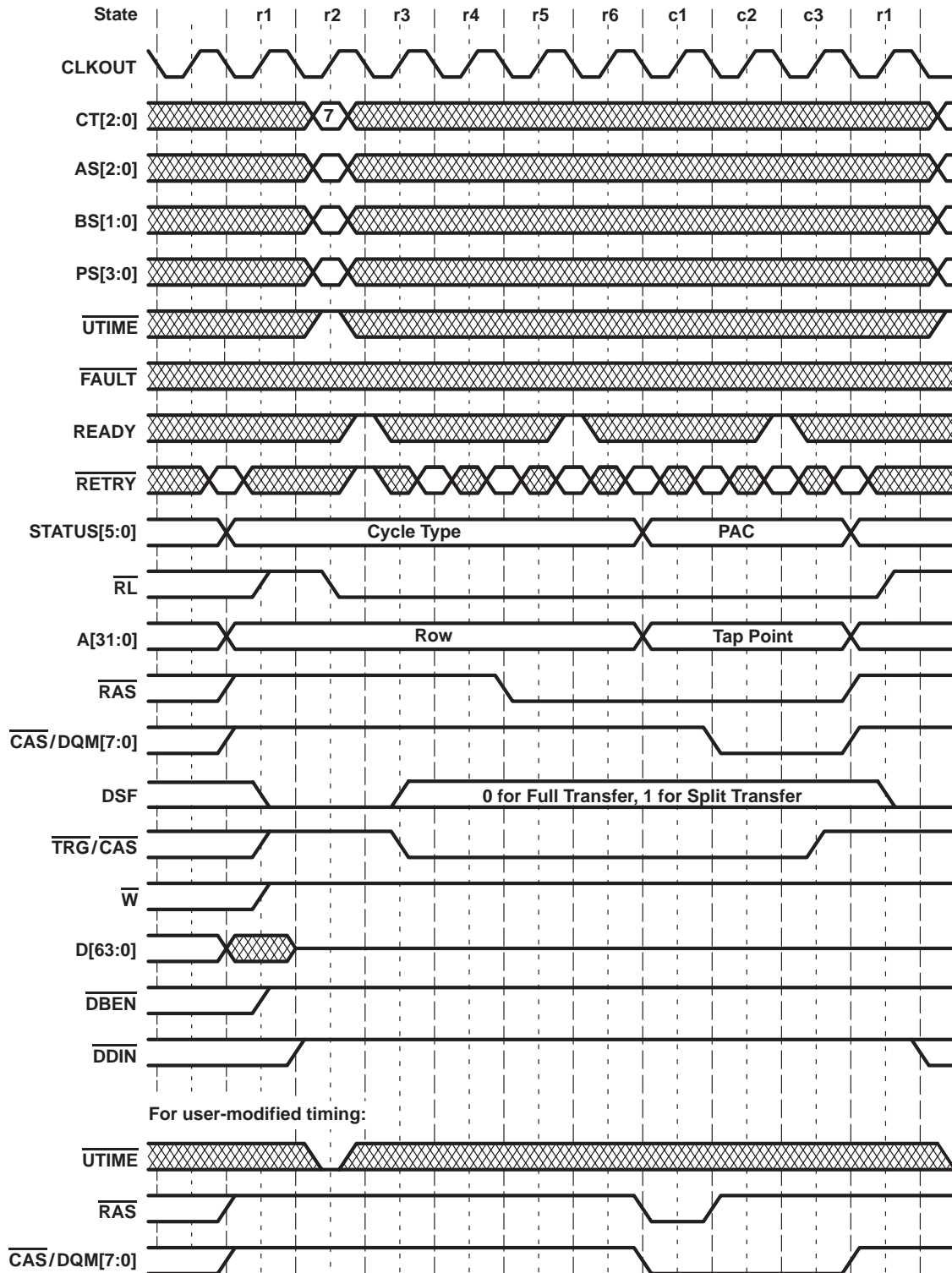

Figure 83. 3 Cycles/Column Read-Transfer and Split-Register Read-Transfer-Cycle Timing



POST OFFICE BOX 1443 • HOUSTON, TEXAS 77251-1443

transfer cycles (continued)

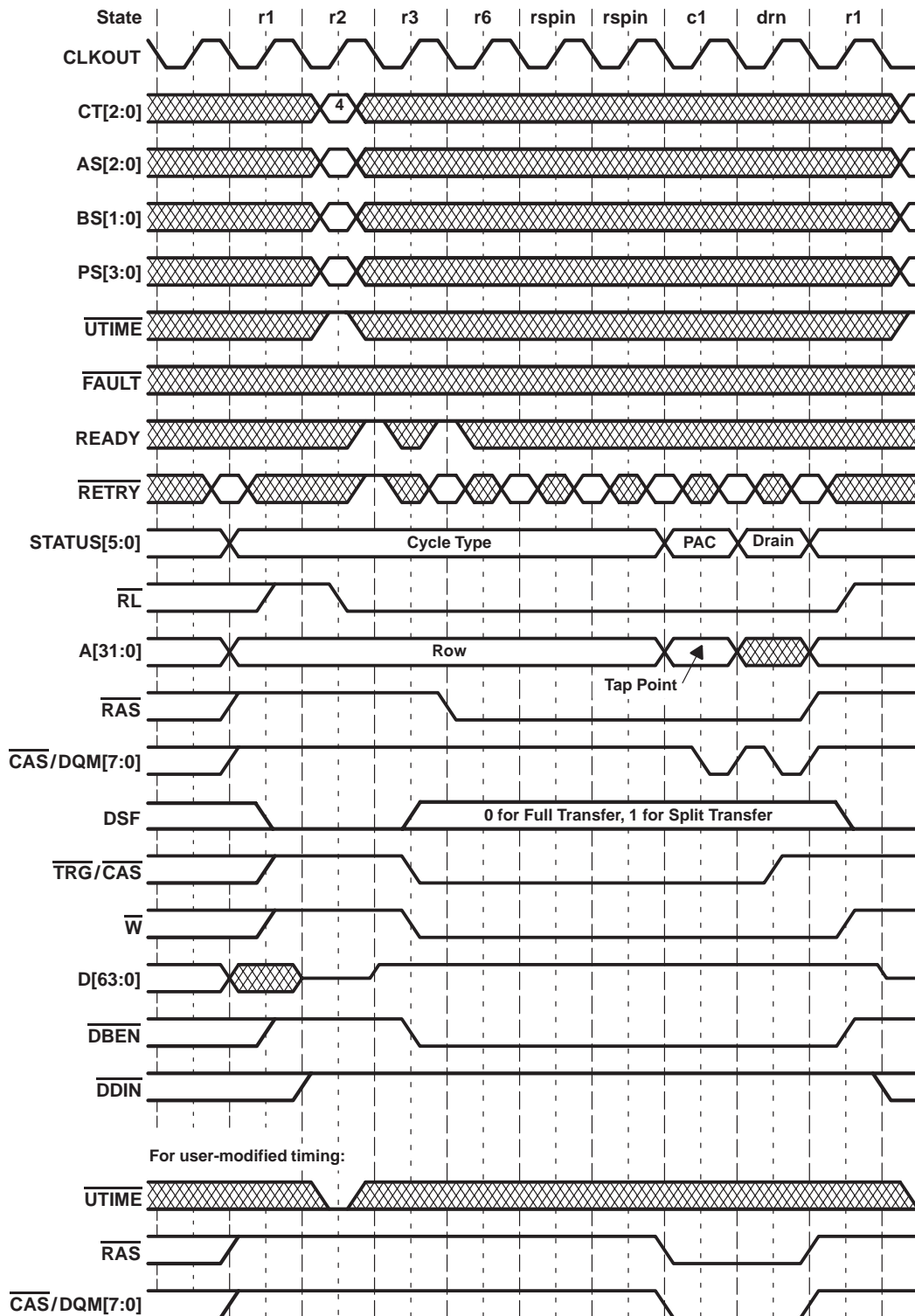

Figure 84. Pipelined 1 Cycle/Column Write-Transfer and Split-Register Write-Transfer-Cycle Timing

# TMS320C80 DIGITAL SIGNAL PROCESSOR

SPRS023B – JULY 1994 – REVISED OCTOBER 1997

## transfer cycles (continued)

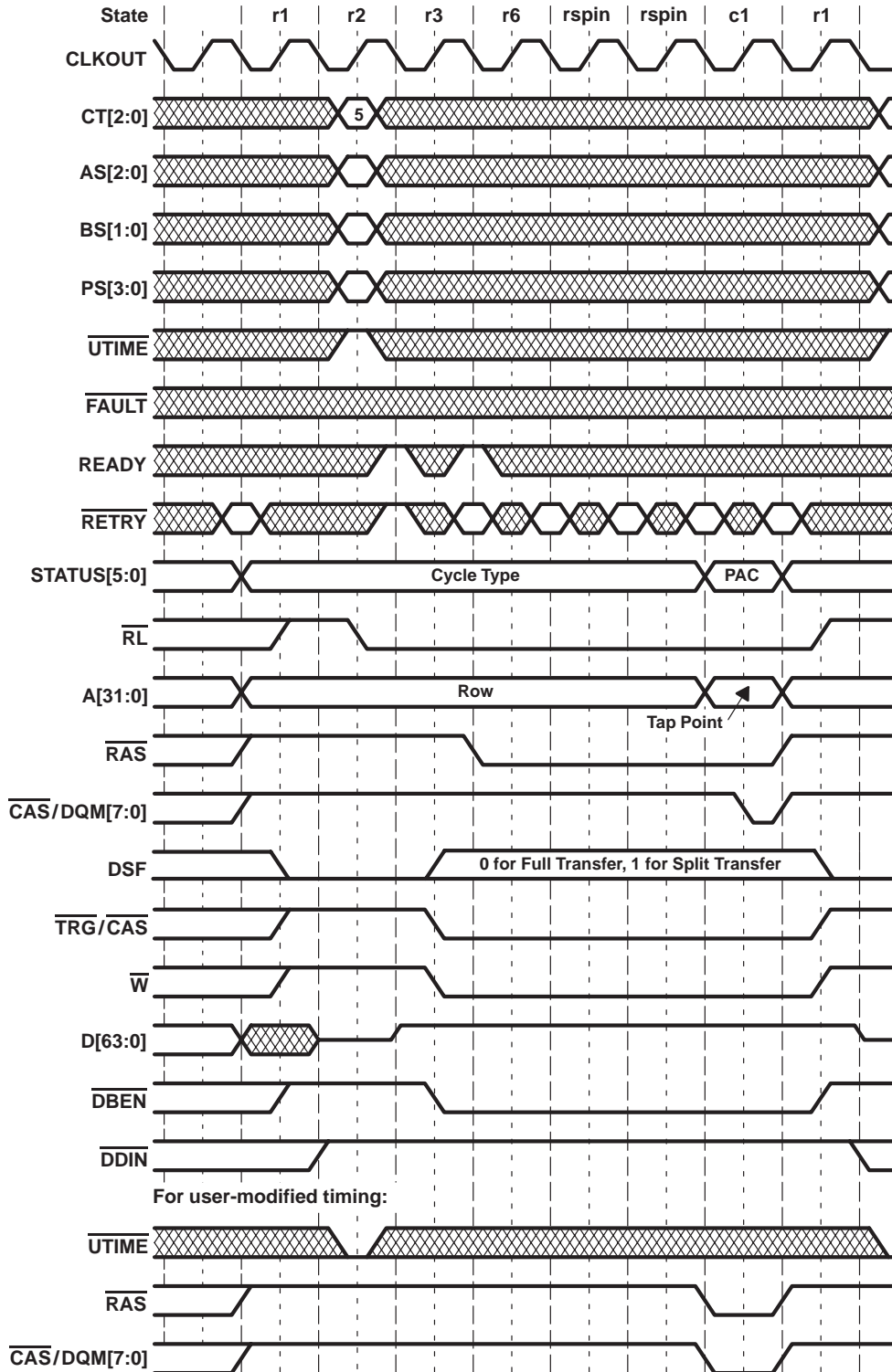

Figure 85. Nonpipelined 1 Cycle/Column Write-Transfer and Split-Register Write-Transfer-Cycle Timing

transfer cycles (continued)

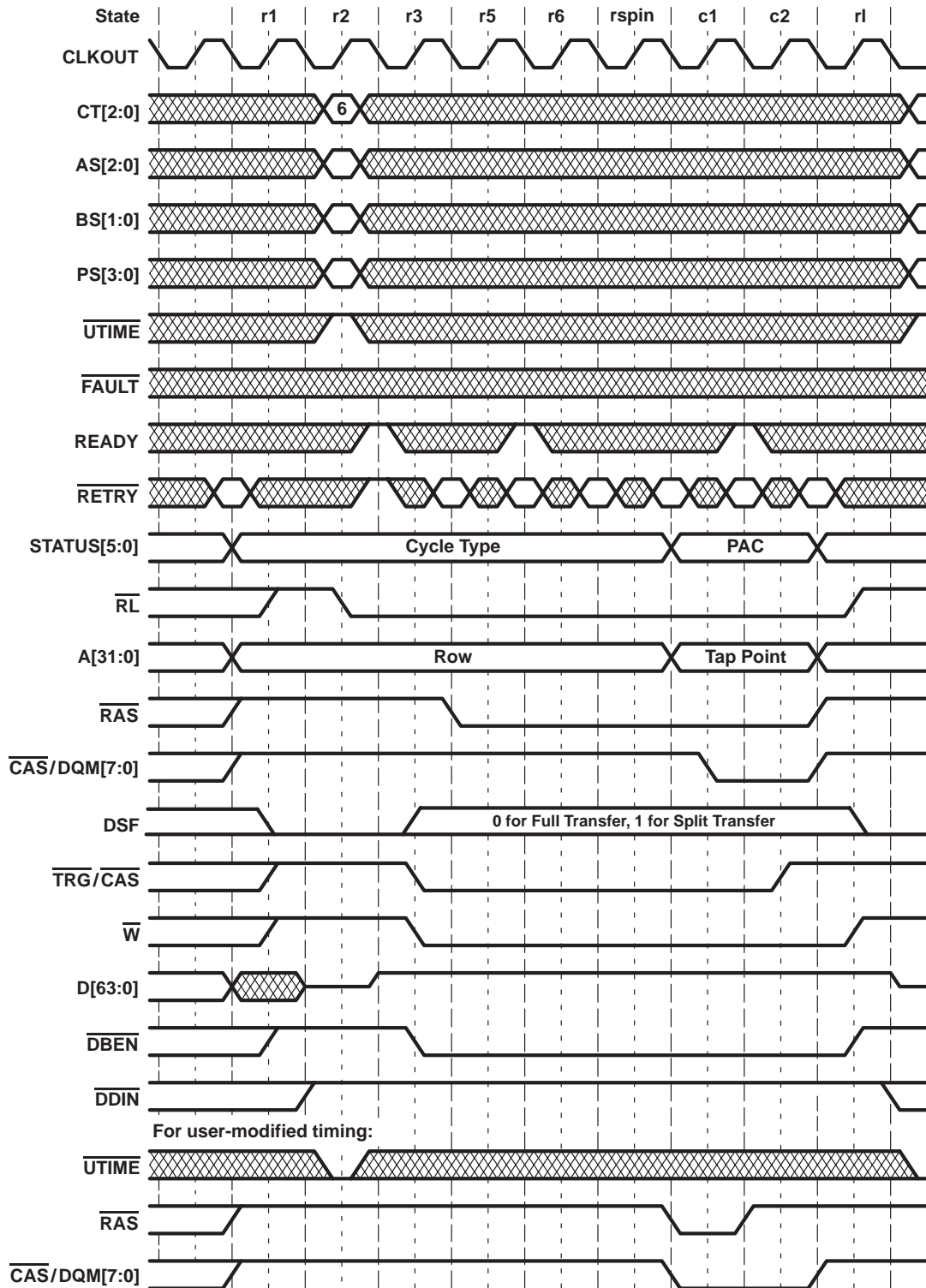

Figure 86. 2 Cycles/Column Write-Transfer and Split-Register Write-Transfer-Cycle Timing

# TMS320C80 DIGITAL SIGNAL PROCESSOR

SPRS023B – JULY 1994 – REVISED OCTOBER 1997

## transfer cycles (continued)

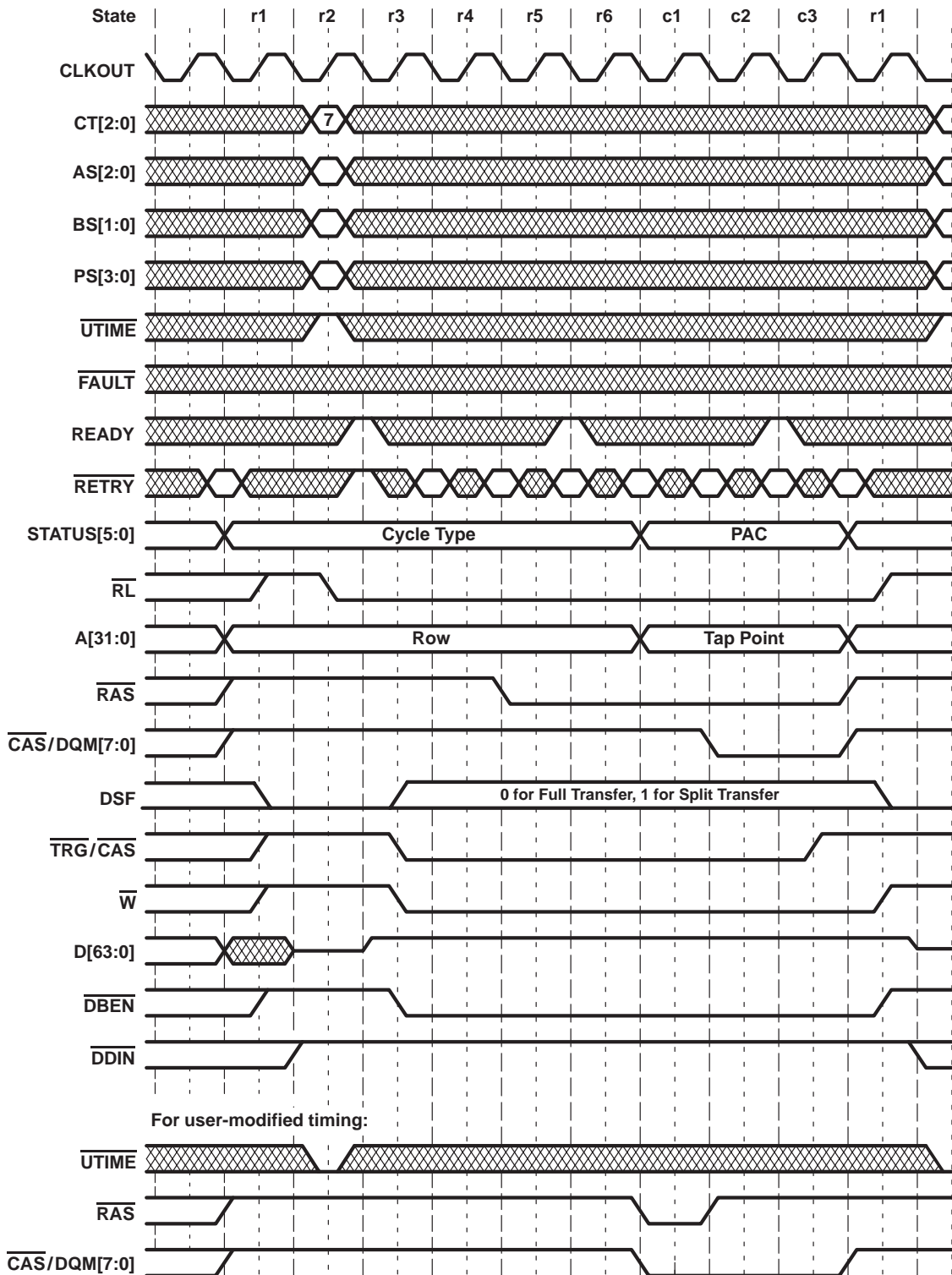

Figure 87. 3 Cycles/Column Write-Transfer and Split-Register Write-Transfer-Cycle Timing

---

### *refresh cycles*

Refresh cycles are generated by the TC at the programmed refresh interval. They are characterized by the following signal activity:

- $\overline{\text{CAS}}$  falls prior to  $\overline{\text{RAS}}$ .
- All  $\overline{\text{CAS}}$  pins ( $\overline{\text{CAS}}/\text{DQM}[7:0]$ ) are active.
- $\overline{\text{TRG}}$ ,  $\overline{\text{W}}$ , and  $\overline{\text{DBEN}}$  all remain inactive (high) because no data transfer occurs.
- DSF remains inactive (low).
- The data bus is driven to the high-impedance state.
- The upper half of the address bus (A[31:16]) contains the refresh pseudo-address and the lower half (A[15:0]) is driven to all zeros.
- If  $\overline{\text{RETRY}}$  is asserted at any sample point during the cycle, the cycle timing is not modified. Instead, the pseudo-address and backlog counters are simply not decremented.
- Selecting user-modified timing has no effect on the cycles.
- Upon completion of the refresh cycle, the memory interface returns to state r1 to await the next access.

See Figure 88 through Figure 90 for refresh cycle timing.

# TMS320C80 DIGITAL SIGNAL PROCESSOR

SPRS023B – JULY 1994 – REVISED OCTOBER 1997

## refresh cycles (continued)

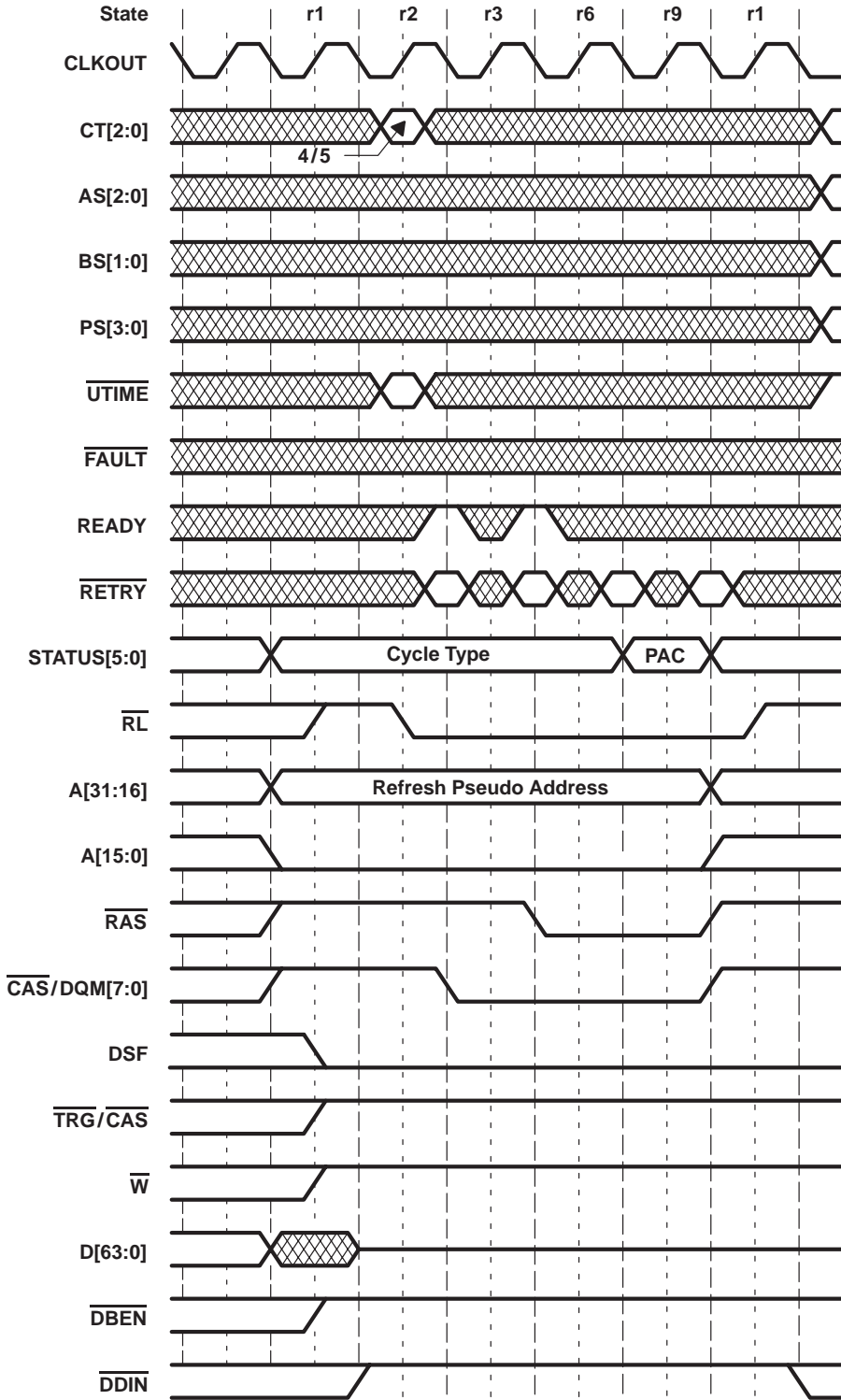

Figure 88. 1-Cycle/Column Refresh-Cycle Timing

refresh cycles (continued)

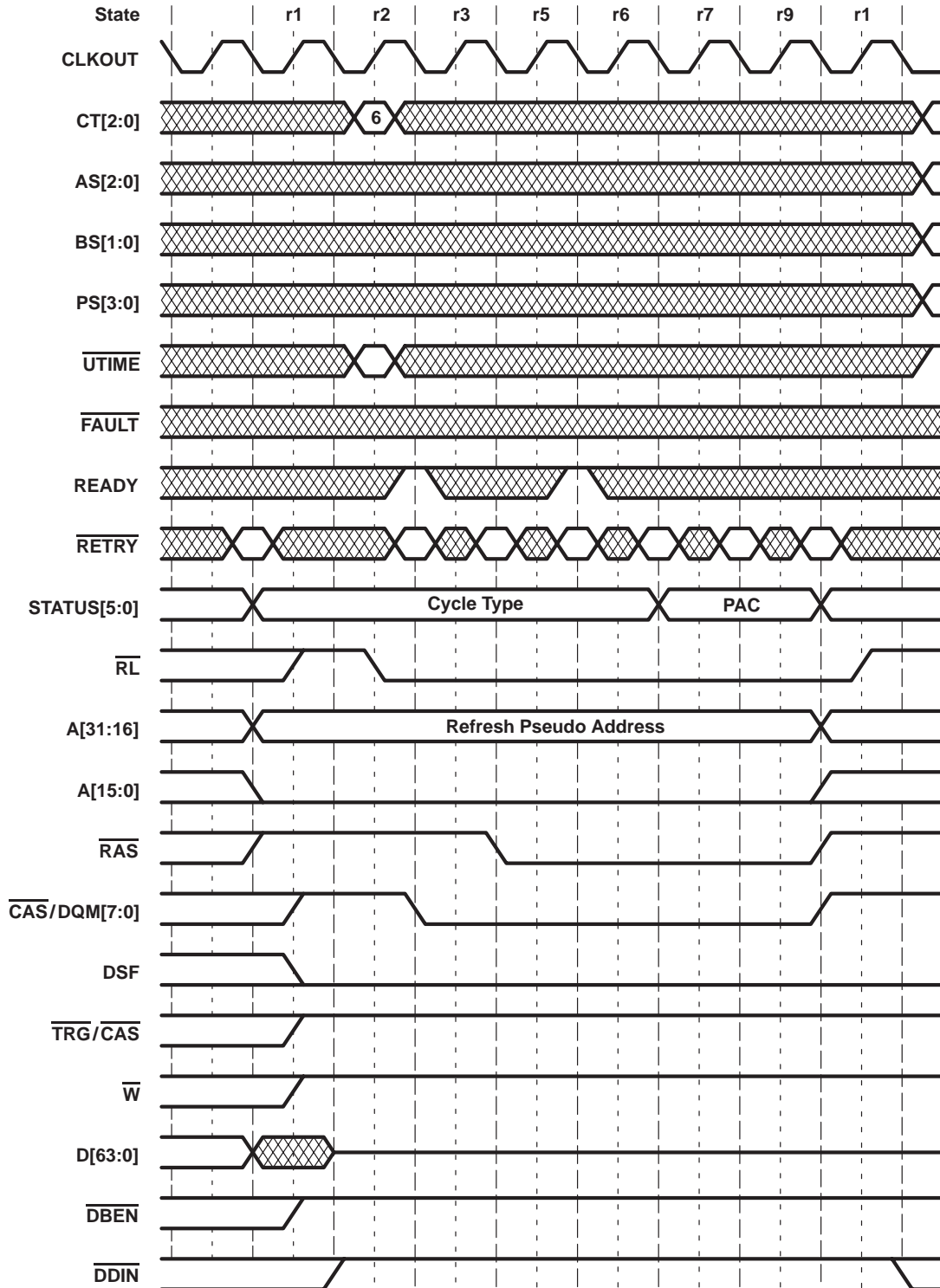

Figure 89. 2 Cycles/Column Refresh-Cycle Timing

# TMS320C80 DIGITAL SIGNAL PROCESSOR

SPRS023B – JULY 1994 – REVISED OCTOBER 1997

## refresh cycles (continued)

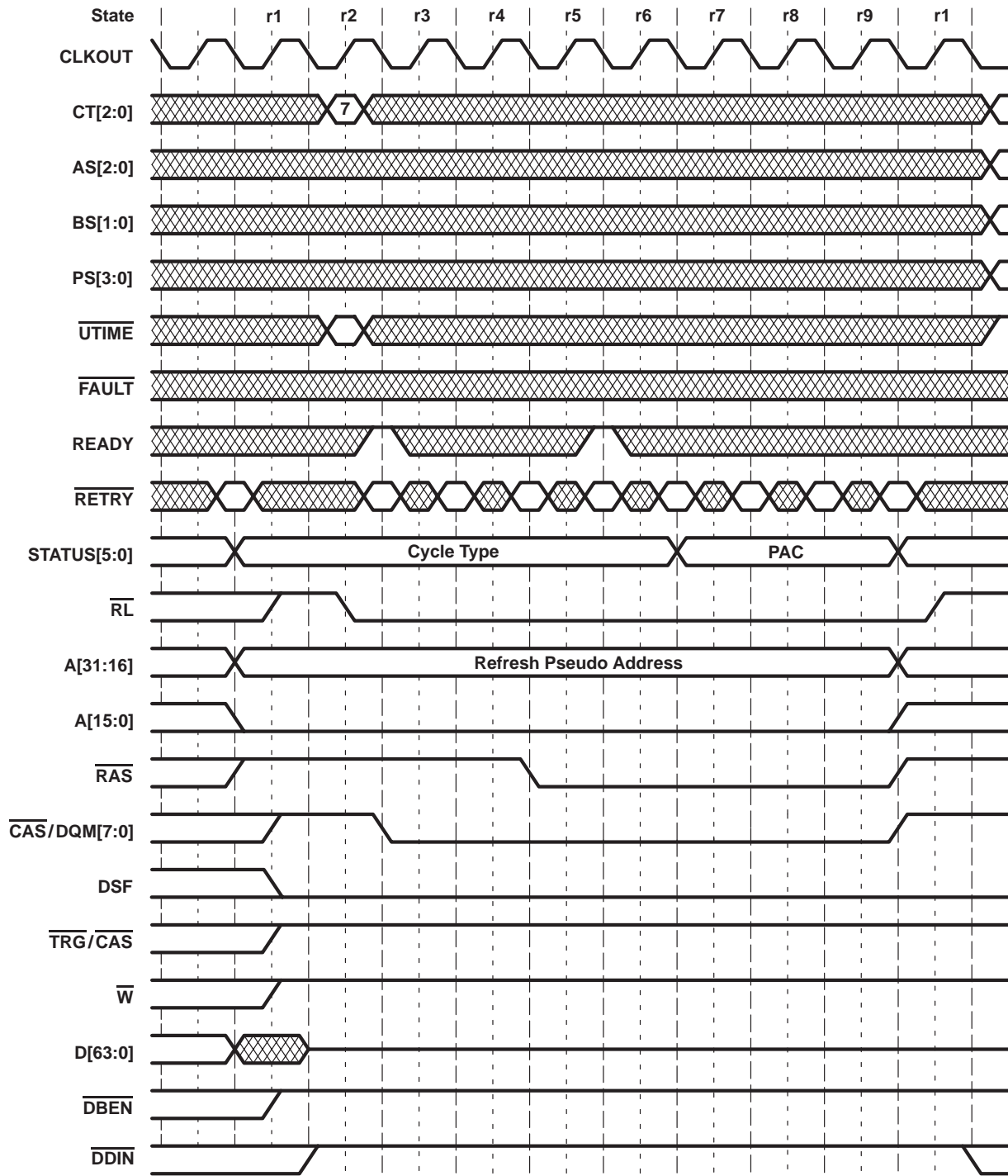

Figure 90. 3 Cycles/Column Refresh-Cycle Timing

---

## SDRAM type cycles

The SDRAM type cycles support the use of SDRAM, SGRAM, or SVRAM devices for single-cycle memory accesses. While SDRAM cycles use the same state sequences as DRAM cycles, the memory-control signal transitions are modified to perform SDRAM command cycles. The supported SDRAM commands are:

|      |   |
|------|---|
| DCAB | Deactivate (precharge) all banks                        |
| ACTV | Activate the selected bank and select the row           |
| READ | Input starting column address and start read operation  |
| WRT  | Input starting column address and start write operation |
| MRS  | Set SDRAM mode register                                 |
| REFR | Auto-refresh cycle with internal address                |
| SRS  | Set special register (color register)                   |
| BLW  | Block write   |

SDRAM cycles begin with an activate (ACTV) command followed by the requested column accesses. When a memory-page change occurs, the selected bank is deactivated with a DCAB command.

The TMS320C80 supports read latencies of 2, 3, or 4 cycles and burst lengths of 1 or 2. These are selected by the CT code and  $\overline{UTIME}$  value input at the start of the access.

The column pipelines for SDRAM accesses are shown in Figure 91. Idle cycles can occur after necessary column accesses have completed or between column accesses due to “bubbles” in the TC data flow pipeline. The pipeline diagrams show the pipeline stages for each access type and when the  $\overline{CAS}/DQM$  signal corresponding to the column access is activated.

# TMS320C80 DIGITAL SIGNAL PROCESSOR

SPRS023B – JULY 1994 – REVISED OCTOBER 1997

## SDRAM type cycles (continued)

| $\overline{\text{CAS}}/\text{DQM}$ | A  | B  | C  |
|------------------------------------|----|----|----|
| Col A                              | c1 | c2 | c3 |
| Col B                              |    | c1 | c2 |
| Col C                              |    |    | c1 |
| Idle                               |    |    |    |

Burst-length 1, 2 cycle latency reads, read transfers, split-read transfers

| $\overline{\text{CAS}}/\text{DQM}$ | A  | B  | C  |
|------------------------------------|----|----|----|
| Col A                              | c1 | c2 | c3 |
| Col B                              |    | c1 | c2 |
| Col C                              |    |    | c1 |
| Idle                               |    |    |    |

Burst-length 1, 3 cycle latency reads, read transfers, split-read transfers

| $\overline{\text{CAS}}/\text{DQM}$ | A  | B  | C  |
|------------------------------------|----|----|----|
| Col A                              | c1 | c2 | c3 |
| Col B                              |    | c1 | c2 |
| Col C                              |    |    | c1 |
| Idle                               |    |    |    |

Burst-length 1, 4 cycle latency reads, read transfers, split-read transfers.

| $\overline{\text{CAS}}/\text{DQM}$ | A  | (B) | C  | (D) | E  | (F) |
|------------------------------------|----|-----|----|-----|----|-----|
| Col A, B                           | c1 | c2  | c3 |     |    |     |
| Col C, D                           |    |     |    | c1  | c2 | c3  |
| Col E, F                           |    |     |    |     |    |     |
| Idle                               |    |     |    |     |    |     |

Burst-length 2, 2 cycle latency reads, read transfers, split-read transfers

| $\overline{\text{CAS}}/\text{DQM}$ | A  | B  | C  |
|------------------------------------|----|----|----|
| Col A                              | c1 |    |    |
| Col B                              |    | c1 |    |
| Col C                              |    |    | c1 |
| Idle                               |    |    |    |

Burst-length 1 writes, block writes, SRSs, write transfers, split-write transfers

| $\overline{\text{CAS}}/\text{DQM}$ | A  | (B) | C | (D) | E  | (F) |
|------------------------------------|----|-----|---|-----|----|-----|
| Col A, B                           | c1 | c2  |   |     |    |     |
| Col C, D                           |    |     |   | c1  | c2 |     |
| Col E, F                           |    |     |   |     |    |     |
| Idle                               |    |     |   |     |    |     |

Burst-length 2, writes

| $\overline{\text{CAS}}/\text{DQM}$ | A  | (B) | C  | (D) | E | (F) |
|------------------------------------|----|-----|----|-----|---|-----|
| Col A, B                           | c1 | c2  | c3 | c4  |   |     |
| Col C, D                           |    |     |    |     |   |     |
| Col E, F                           |    |     |    |     |   |     |
| Idle                               |    |     |    |     |   |     |

Burst-length 2, 3 cycle latency reads, read transfers, split-read transfers

| $\overline{\text{CAS}}/\text{DQM}$ | A  | B  | C  |
|------------------------------------|----|----|----|
| Col A                              | c1 |    |    |
| Col B                              |    | c1 |    |
| Col C                              |    |    | c1 |
| Idle                               |    |    |    |

Burst-length 2, block writes, write transfers, split-write transfers

| $\overline{\text{CAS}}/\text{DQM}$ | A  | (B) | C  | (D) | E  | (F) |
|------------------------------------|----|-----|----|-----|----|-----|
| Col A, B                           | c1 | c2  | c3 | c4  | c5 |     |
| Col C, D                           |    |     |    |     |    |     |
| Col E, F                           |    |     |    |     |    |     |
| Idle                               |    |     |    |     |    |     |

Burst-length 2, 4 cycle latency reads, read transfers, split-read transfers.

Figure 91. SDRAM Column Pipelines



***special SDRAM cycles***

To initialize the SDRAM properly, the TMS320C80 performs two special SDRAM cycles after reset. The 'C80 first performs a deactivate cycle on all banks (DCAB) and then initializes the SDRAM mode register with a mode register set (MRS) cycle. The CT code input at the start of the MRS cycle determines the burst length and latency that is programmed into the SDRAM mode register (see Figure 92 and Figure 93).

*special SDRAM cycles (continued)*

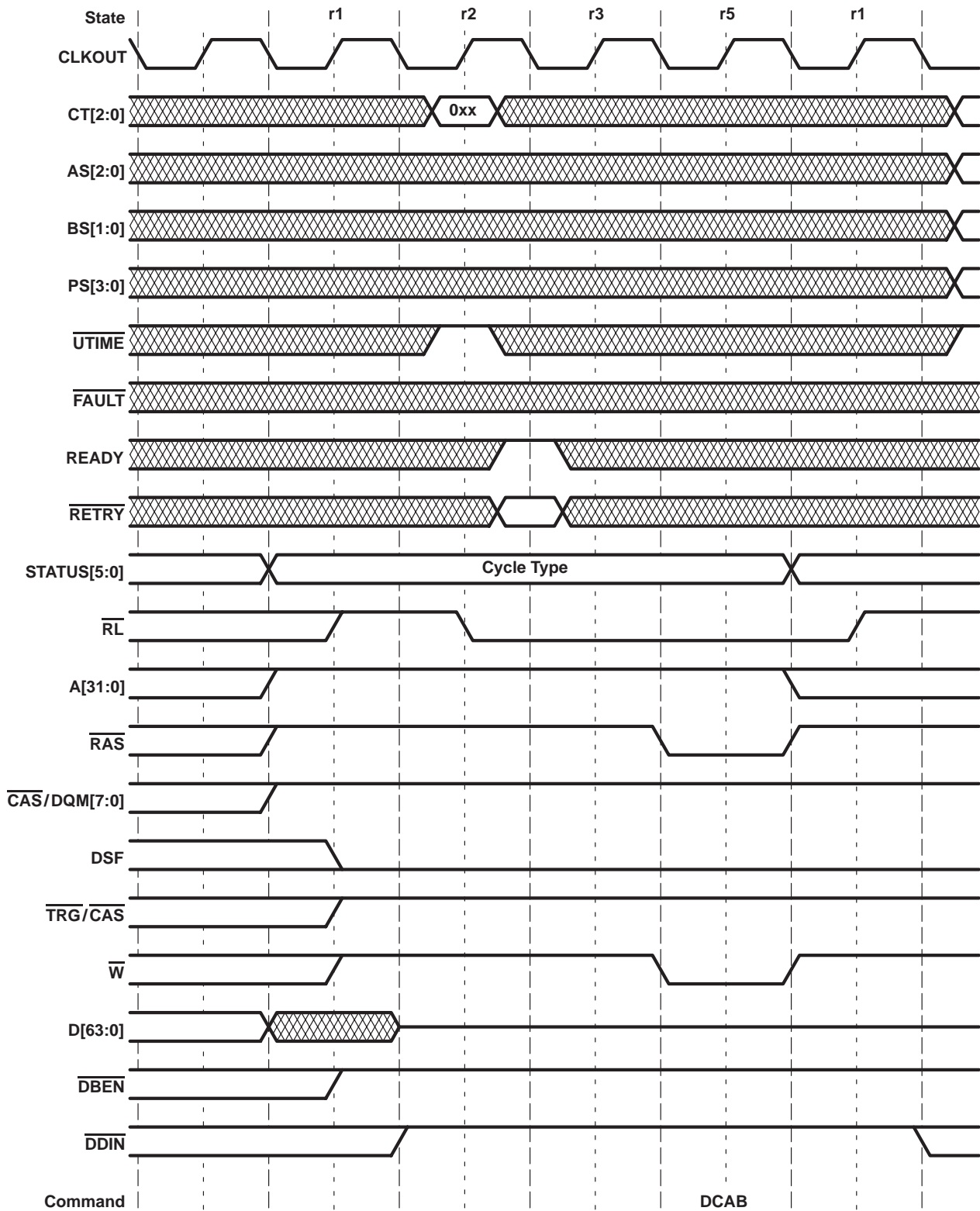

Figure 92. SDRAM Power-Up Deactivate Cycle Timing

special SDRAM cycles (continued)

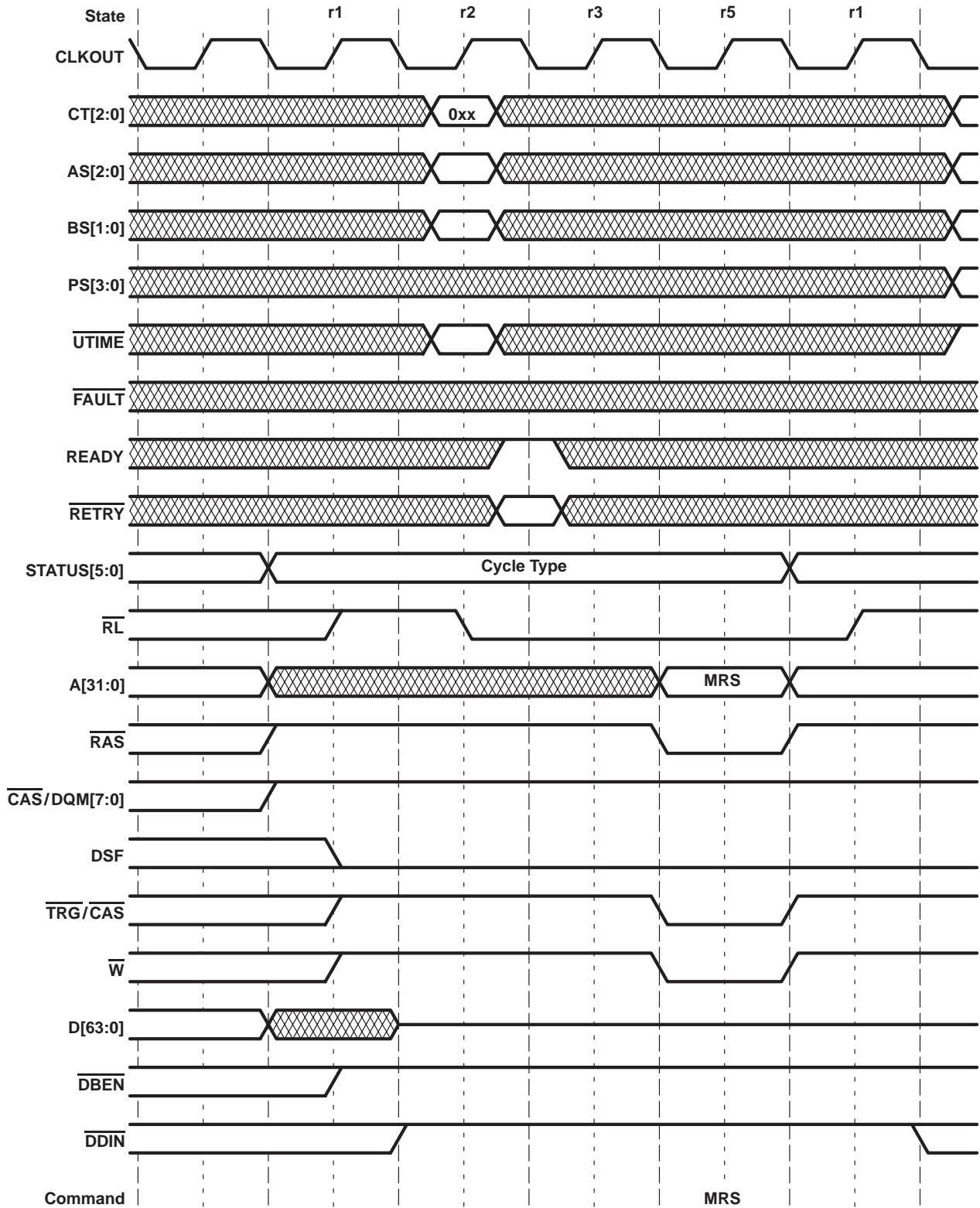

Figure 93. SDRAM Mode Register Set-Cycle Timing

# TMS320C80

## DIGITAL SIGNAL PROCESSOR

SPRS023B – JULY 1994 – REVISED OCTOBER 1997

---

### ***SDRAM read cycles***

Read cycles begin with an activate (ACTV) command to activate the bank and to select the row. The TC outputs the column address and activates the  $\overline{\text{TRG}}/\overline{\text{CAS}}$  strobe for each read command. For burst length 1 accesses, a read command can occur on each cycle. For burst-length 2 accesses, a read command can occur every two cycles. The TC places D[63:0] into the high-impedance state, allowing it to be driven by the memory, and latches input data during the appropriate column state. The TC always reads 64 bits and extracts and aligns the appropriate bytes. Invalid bytes for bus sizes of less than 64 bits are discarded. The  $\overline{\text{CAS}}/\overline{\text{DQM}}$  strobes are activated two cycles before input data is latched. If the second column in a burst is not required, then  $\overline{\text{CAS}}/\overline{\text{DQM}}$  is not activated. During peripheral device packet transfers,  $\overline{\text{DBEN}}$  remains high (see Figure 94 through Figure 99).



SDRAM read cycles (continued)

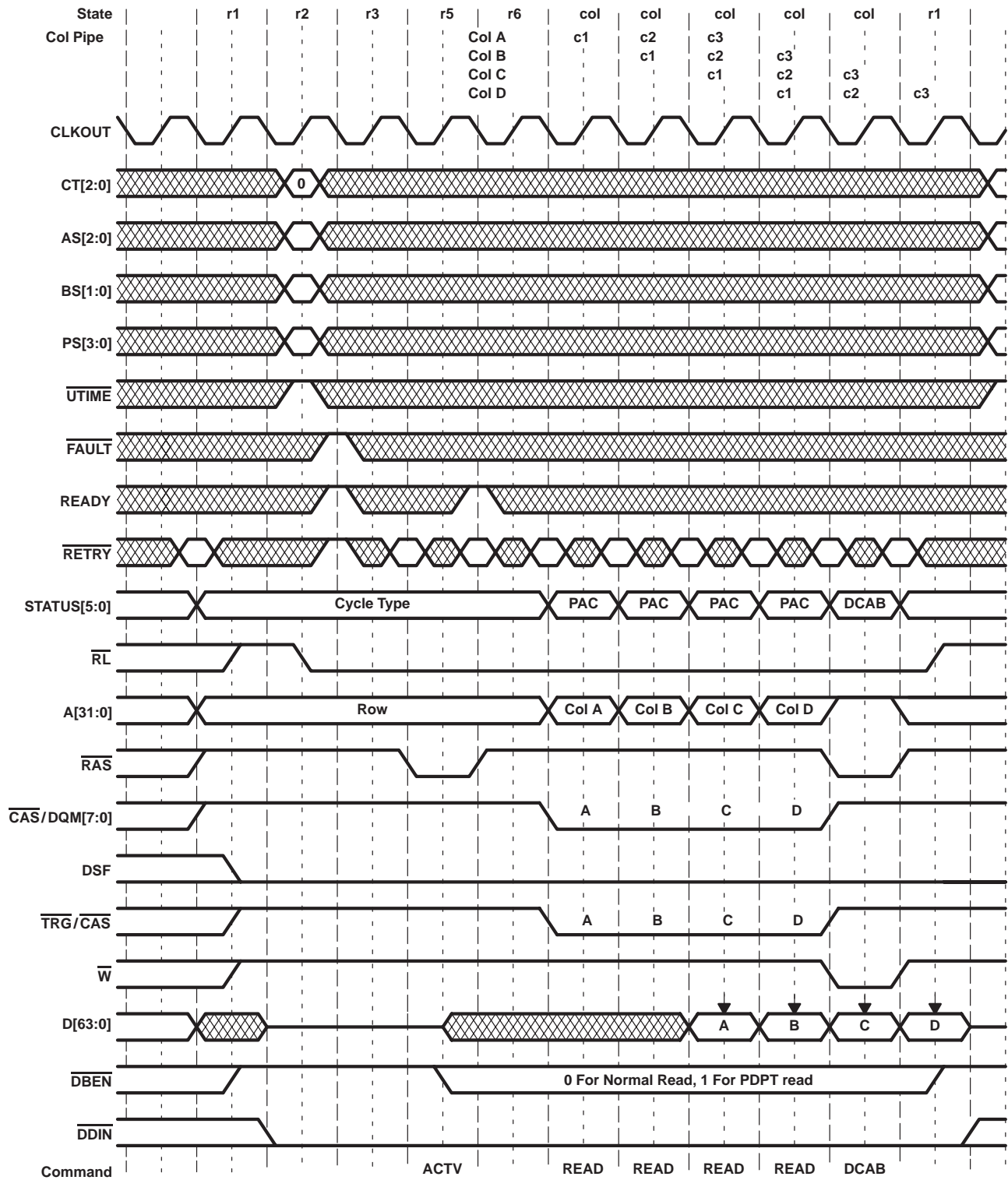
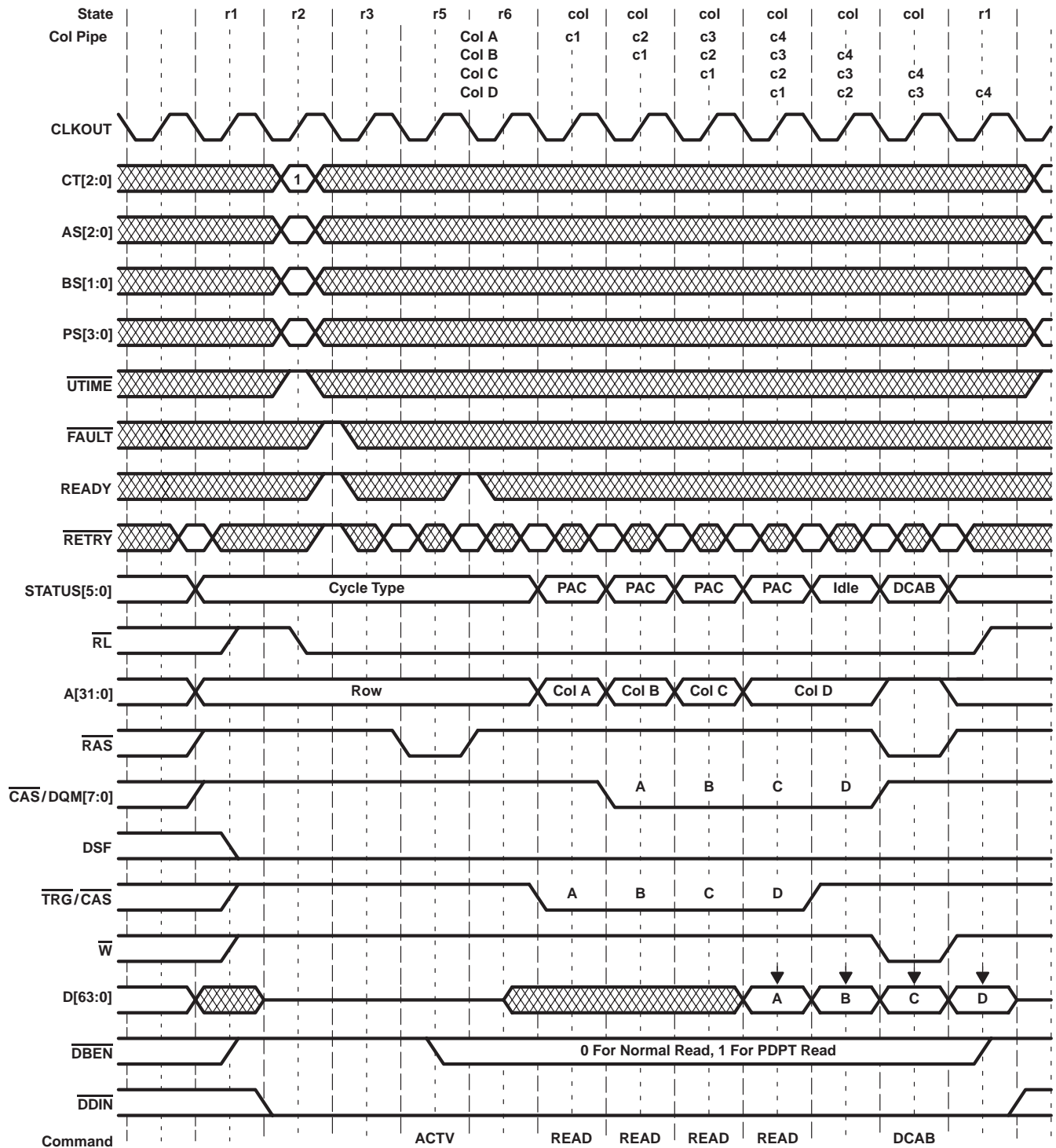

Figure 94. SDRAM Burst-Length 1, 2 Cycle Latency Read-Cycle Timing

**SDRAM read cycles (continued)**



**Figure 95. SDRAM Burst-Length 1, 3 Cycle Latency Read-Cycle Timing**

SDRAM read cycles (continued)

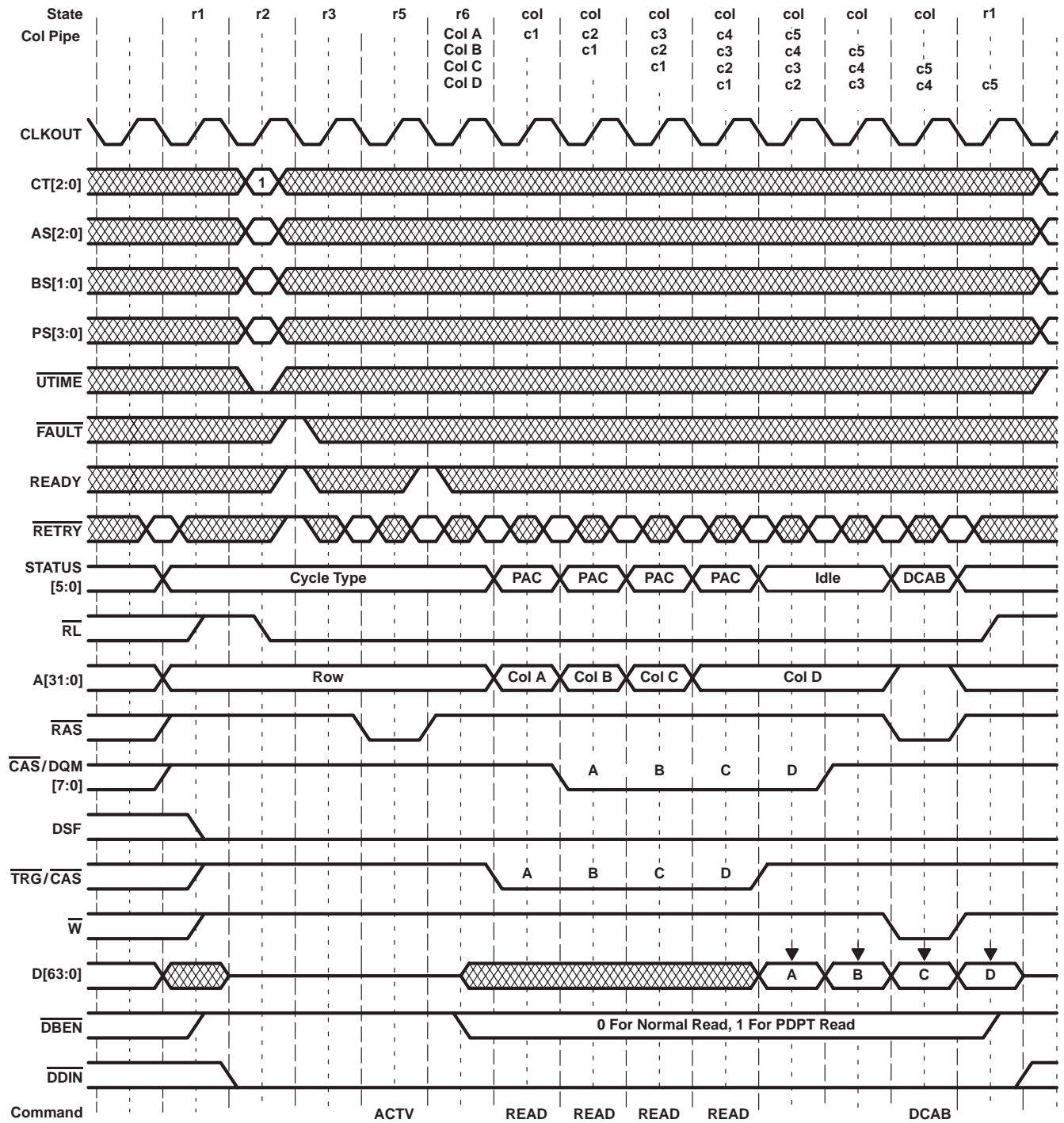

Figure 96. SDRAM Burst-Length 1, 4 Cycle Latency Read-Cycle Timing

# TMS320C80 DIGITAL SIGNAL PROCESSOR

SPRS023B – JULY 1994 – REVISED OCTOBER 1997

## SDRAM read cycles (continued)

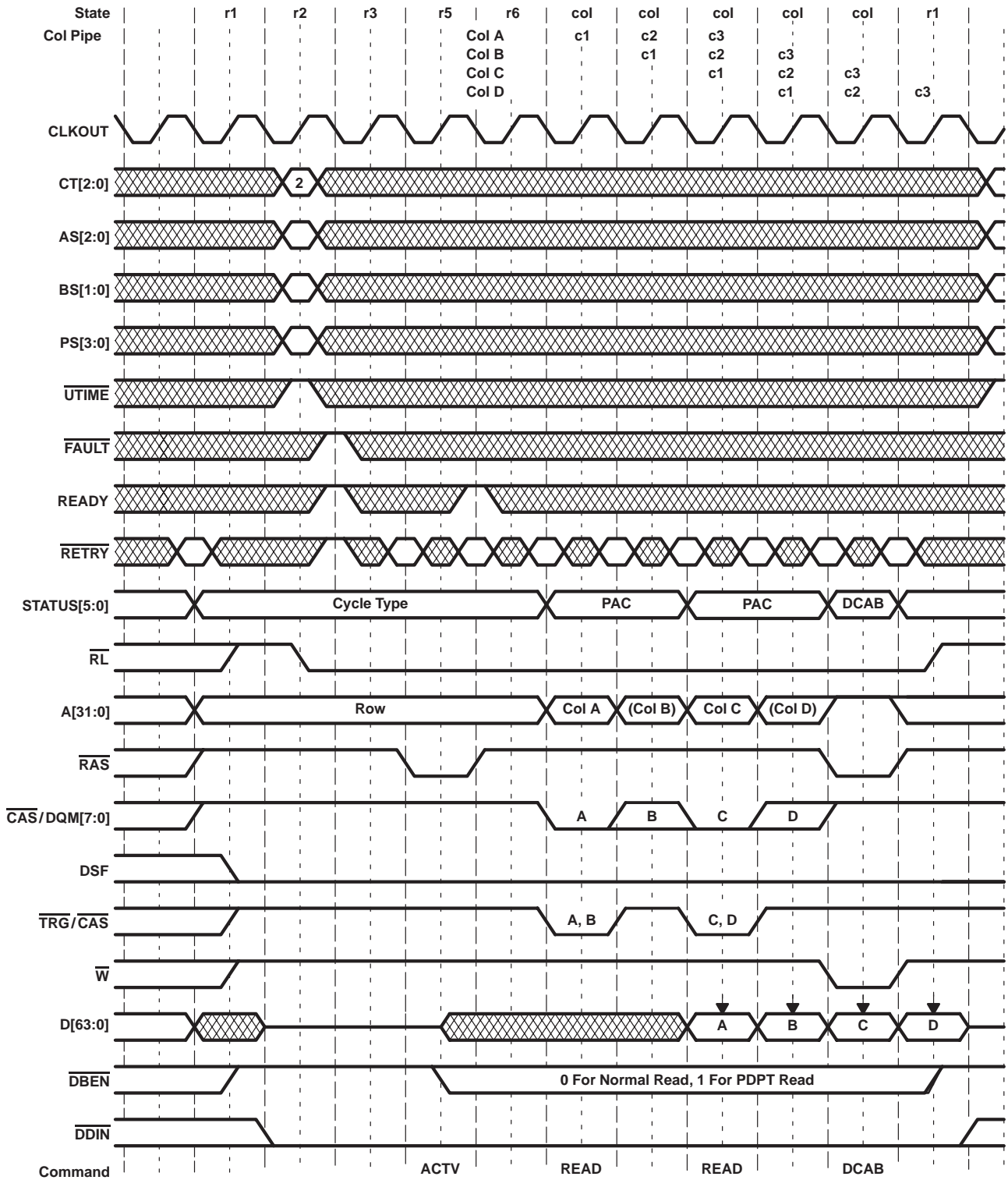

Figure 97. SDRAM Burst-Length 2, 2 Cycle Latency Read-Cycle Timing



SDRAM read cycles (continued)

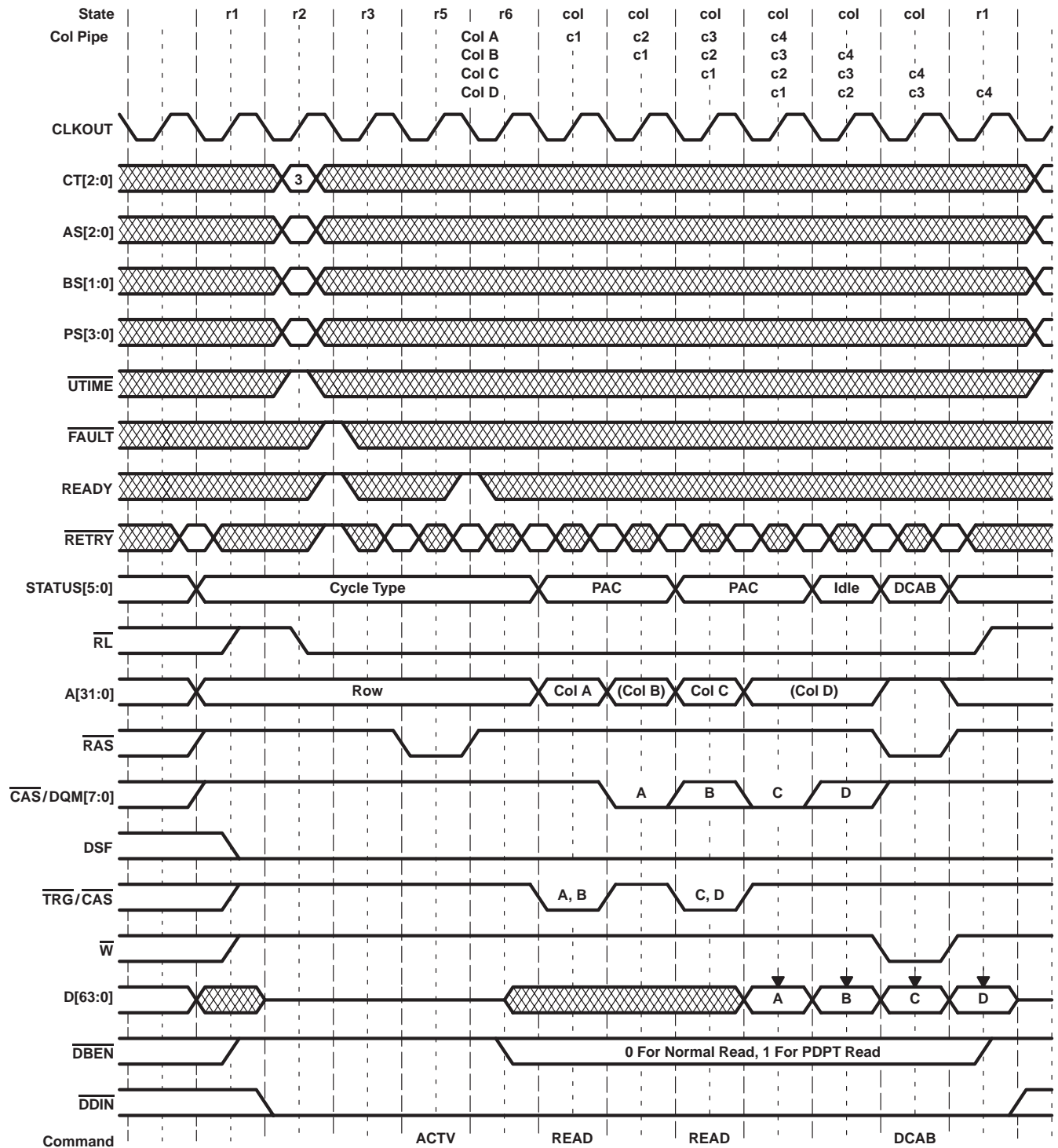

Figure 98. SDRAM Burst-Length 2, 3 Cycle Latency Read-Cycle Timing

# TMS320C80 DIGITAL SIGNAL PROCESSOR

SPRS023B – JULY 1994 – REVISED OCTOBER 1997

## SDRAM read cycles (continued)

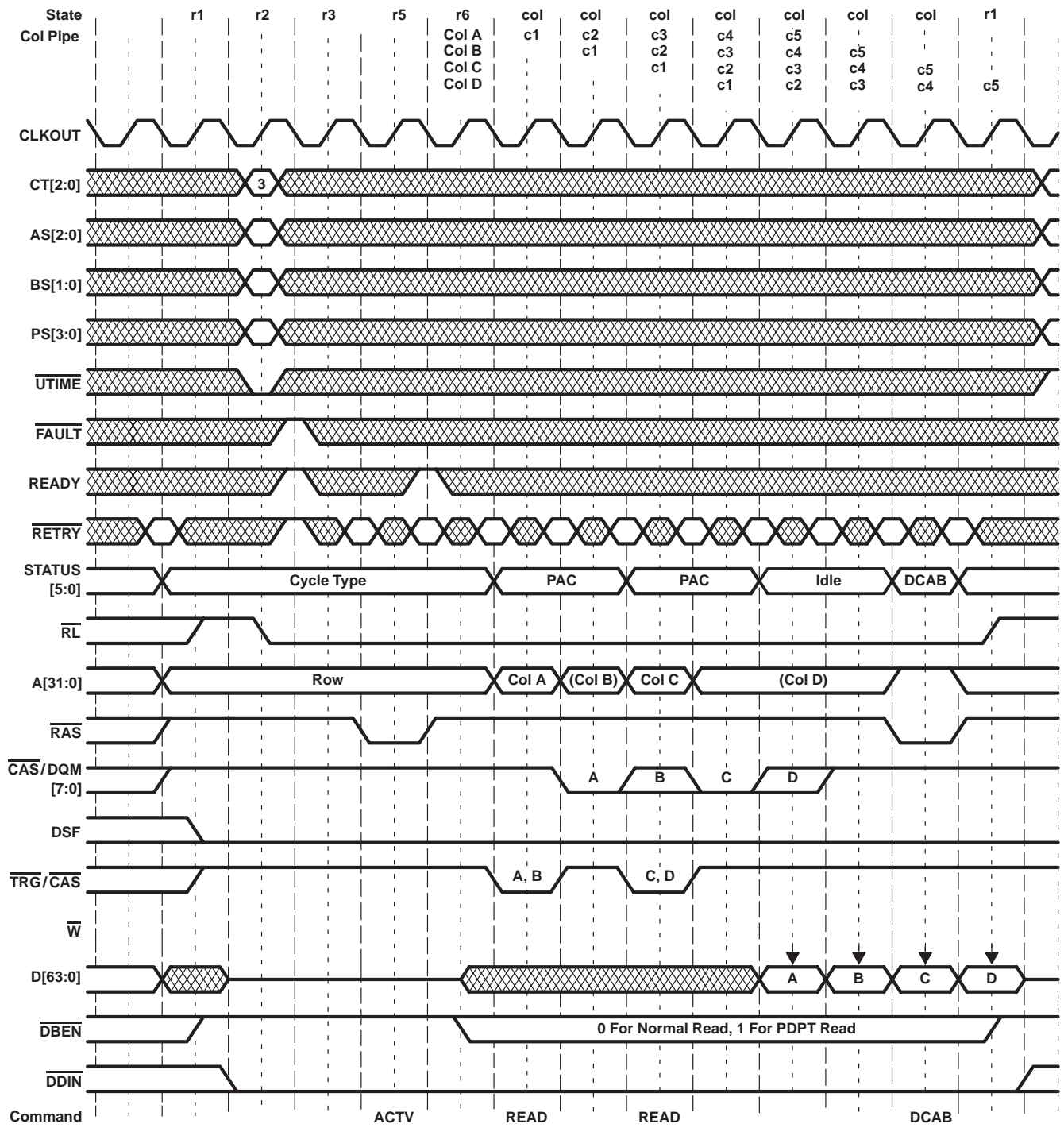

Figure 99. SDRAM Burst-Length 2, 4 Cycle Latency Read-Cycle Timing



### ***SDRAM write cycles***

Write cycles begin with an activate (ACTV) command to activate the bank and select the row. The TC outputs the column address and activates the  $\overline{\text{TRG/CAS}}$  and  $\overline{\text{W}}$  strobes for each write command. For burst-length 1 accesses, a write command can occur on each cycle. For burst-length 2 accesses, a write command can occur every two cycles. The TC drives data out on D[63:0] during each cycle of an active-write command and indicates valid bytes by driving the appropriate  $\overline{\text{CAS/DQM}}$  strobes low. During peripheral device packet transfers,  $\overline{\text{DBEN}}$  remains high and D[63:0] are placed in the high-impedance state so that the peripheral can drive data into the memories. For SDRAM write cycles, see Figure 100 and Figure 101.

# TMS320C80 DIGITAL SIGNAL PROCESSOR

SPRS023B – JULY 1994 – REVISED OCTOBER 1997

## SDRAM write cycles (continued)

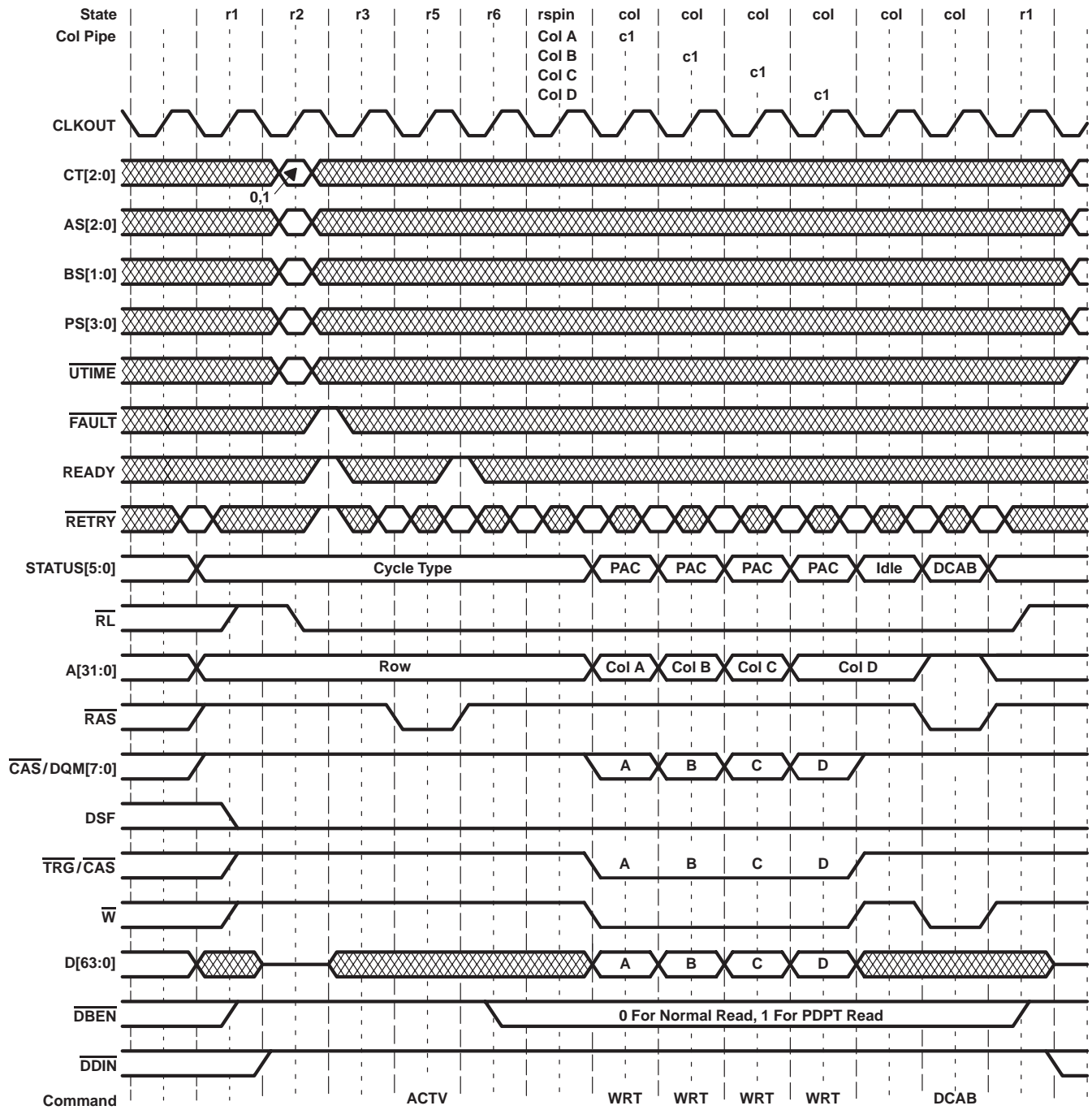
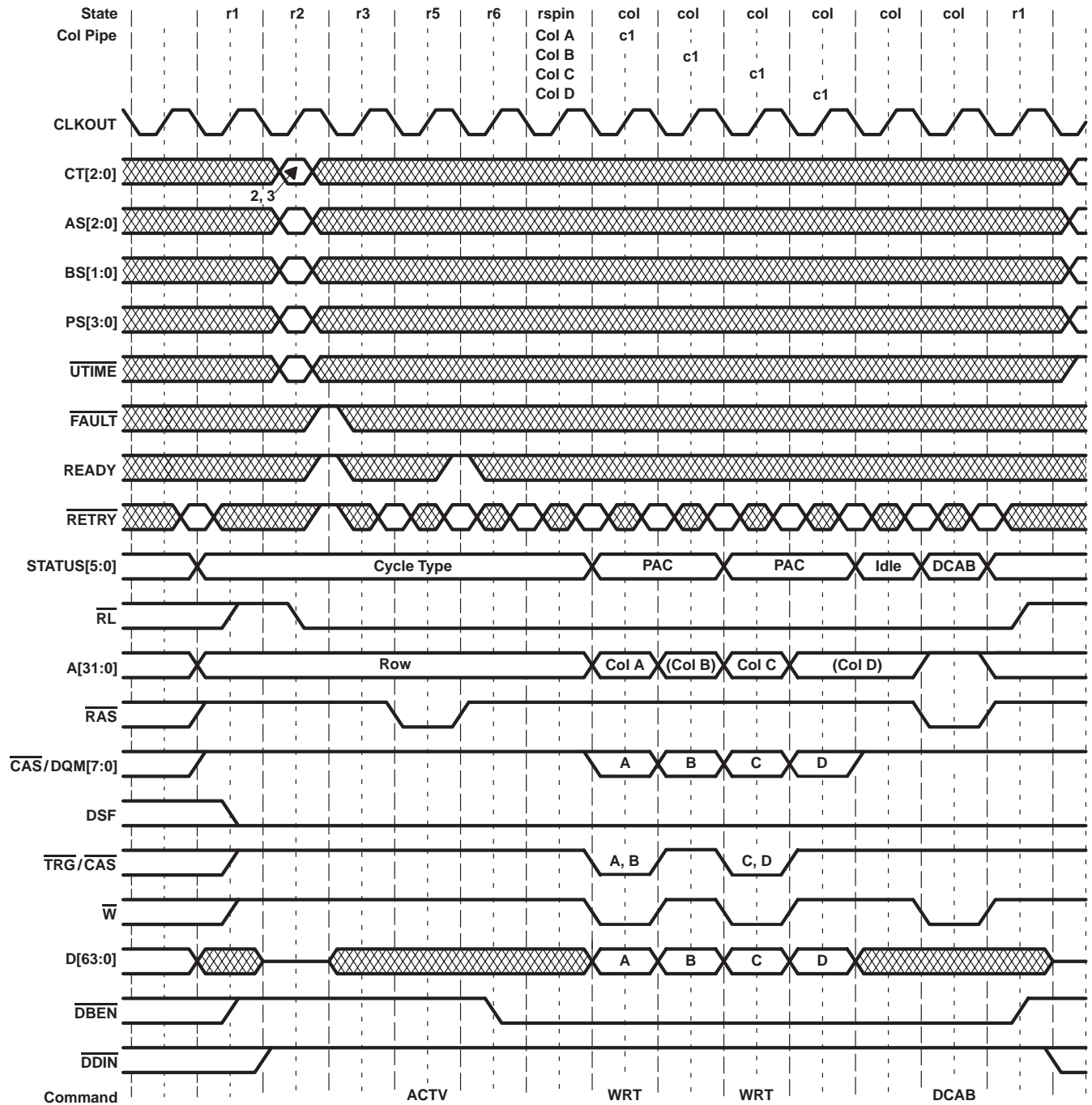

Figure 100. SDRAM Burst-Length 1 Write-Cycle Timing



POST OFFICE BOX 1443 • HOUSTON, TEXAS 77251-1443

**SDRAM write cycles (continued)**



**Figure 101. SDRAM Burst-Length 2 Write-Cycle Timing**

**special register set cycles**

Special register set (SRS) cycles are used to program control registers within an SVRAM or SGRAM. The 'C80 only supports programming of the color register for use with block writes. The cycle is similar to a single burst length 1 write cycle but DSF is driven high. The values output on the 'C80 address bits cause the color register to be selected as shown in Figure 102 (see Figure 103).

# TMS320C80 DIGITAL SIGNAL PROCESSOR

SPRS023B – JULY 1994 – REVISED OCTOBER 1997

## special register set cycles (continued)

| SDRAM Address Pin      | BS | A8 | A7 | A6 | A5 | A4 | A3            | A2 | A1 | A0 |
|------------------------|----|----|----|----|----|----|---------------|----|----|----|
| SDRAM Function         | 0  | 0  | 0  | LC | LM | LS | Stop Register |    |    |    |
| TMS320C80 Output Value | 0  | 0  | 0  | 1  | 0  | 0  | 0             | 0  | 0  | 0  |

Figure 102. Special-Register-Set Value

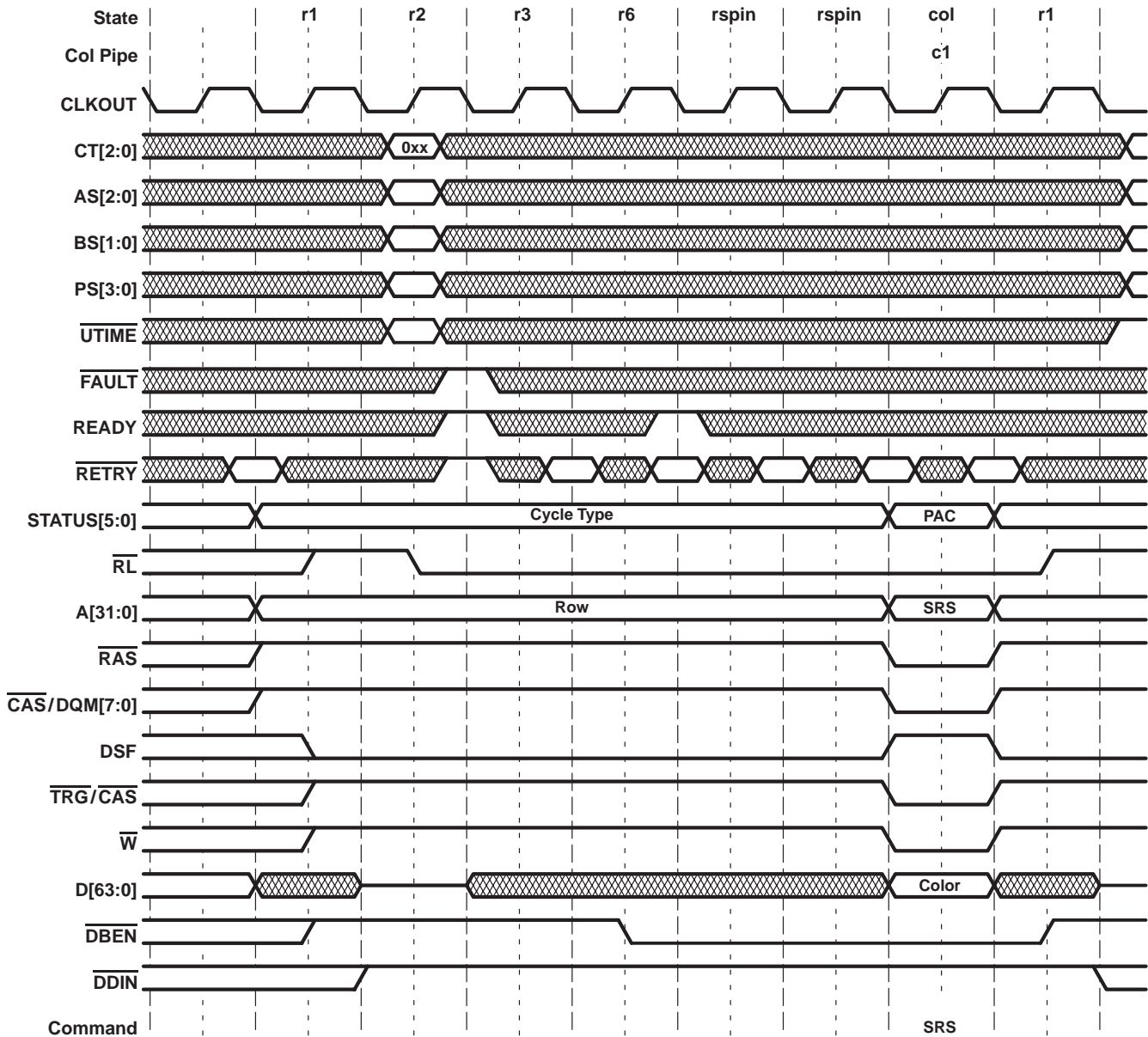

Figure 103. SDRAM SRS-Cycle Timing

**SDRAM block-write cycles**

Block-write cycles allow SDRAMs and SGRAMs to write a stored color value to multiple column locations in a single access. Block-write cycles are similar to write cycles except that DSF is driven high to indicate a block-write command. Because burst is not supported for block write, burst length 2 accesses generate a single block-write every other clock cycle (see Figure 104 and Figure 105).

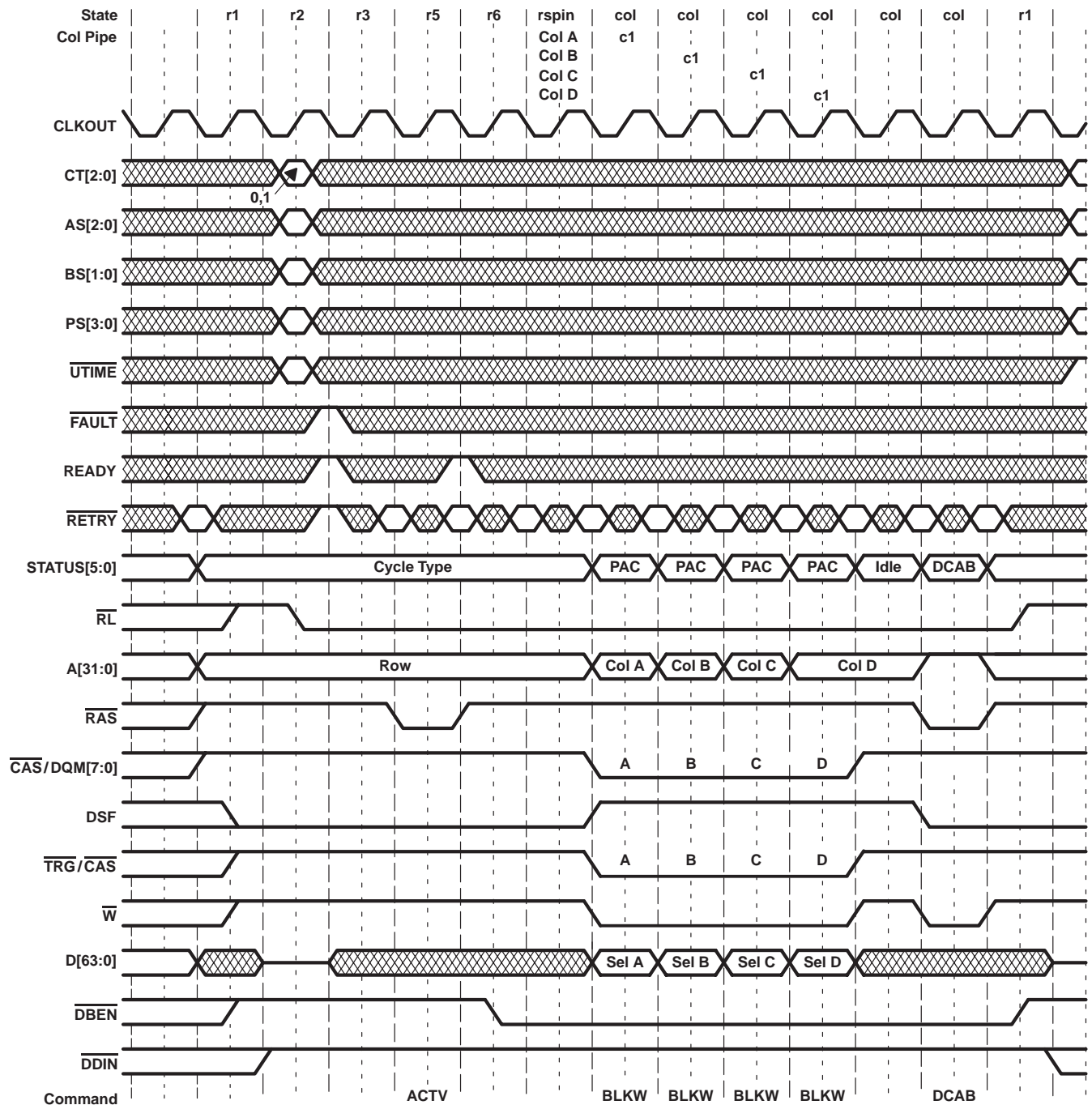
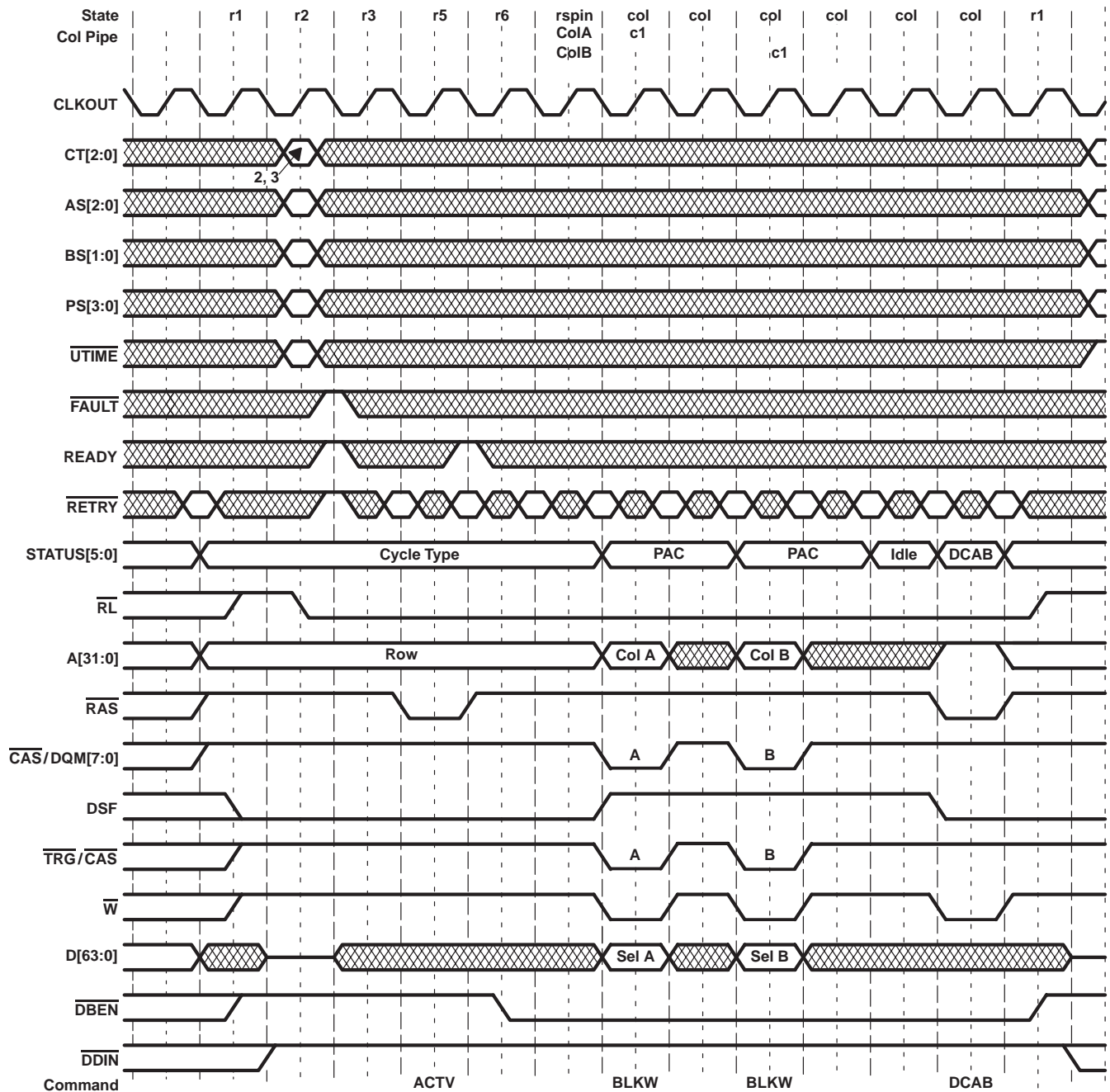

Figure 104. SDRAM Burst-Length 1 Block-Write Cycle Timing

**SDRAM block-write cycles (continued)**



**Figure 105. SDRAM Burst-Length 2 Block-Write Cycle Timing**

**SVRAM transfer cycles**

The SVRAM read- and write-transfer cycles transfer data between the SVRAM memory-array and the serial register (SAM). The TMS320C80 supports both normal and split transfers for SVRAMs. Read-and split-read transfers resemble a standard read cycle. Write-and split-write transfers resemble a standard write cycle. Because the 'C80's TRG output is used as CAS, external logic must generate a TRG signal (by decoding STATUS) to enable the SVRAM transfer cycle. The value output on A[31:0] at column time represents the SAM tap point (see Figure 106 through Figure 113).

SVRAM transfer cycles (continued)

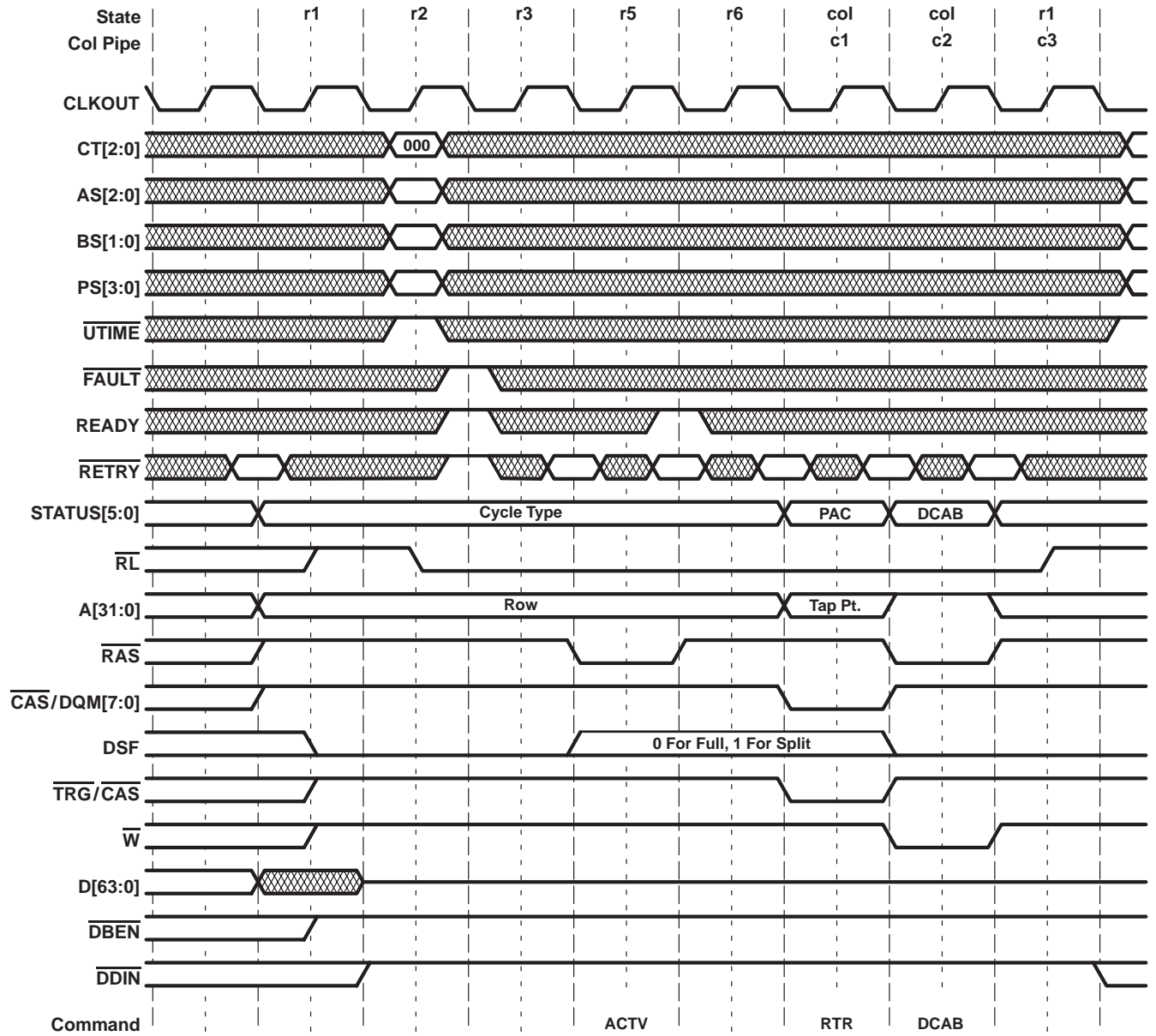

Figure 106. SVRAM Burst-Length 1, 2 Cycle Latency Read-Transfer Cycle Timing

# TMS320C80 DIGITAL SIGNAL PROCESSOR

SPRS023B – JULY 1994 – REVISED OCTOBER 1997

## SVRAM transfer cycles (continued)

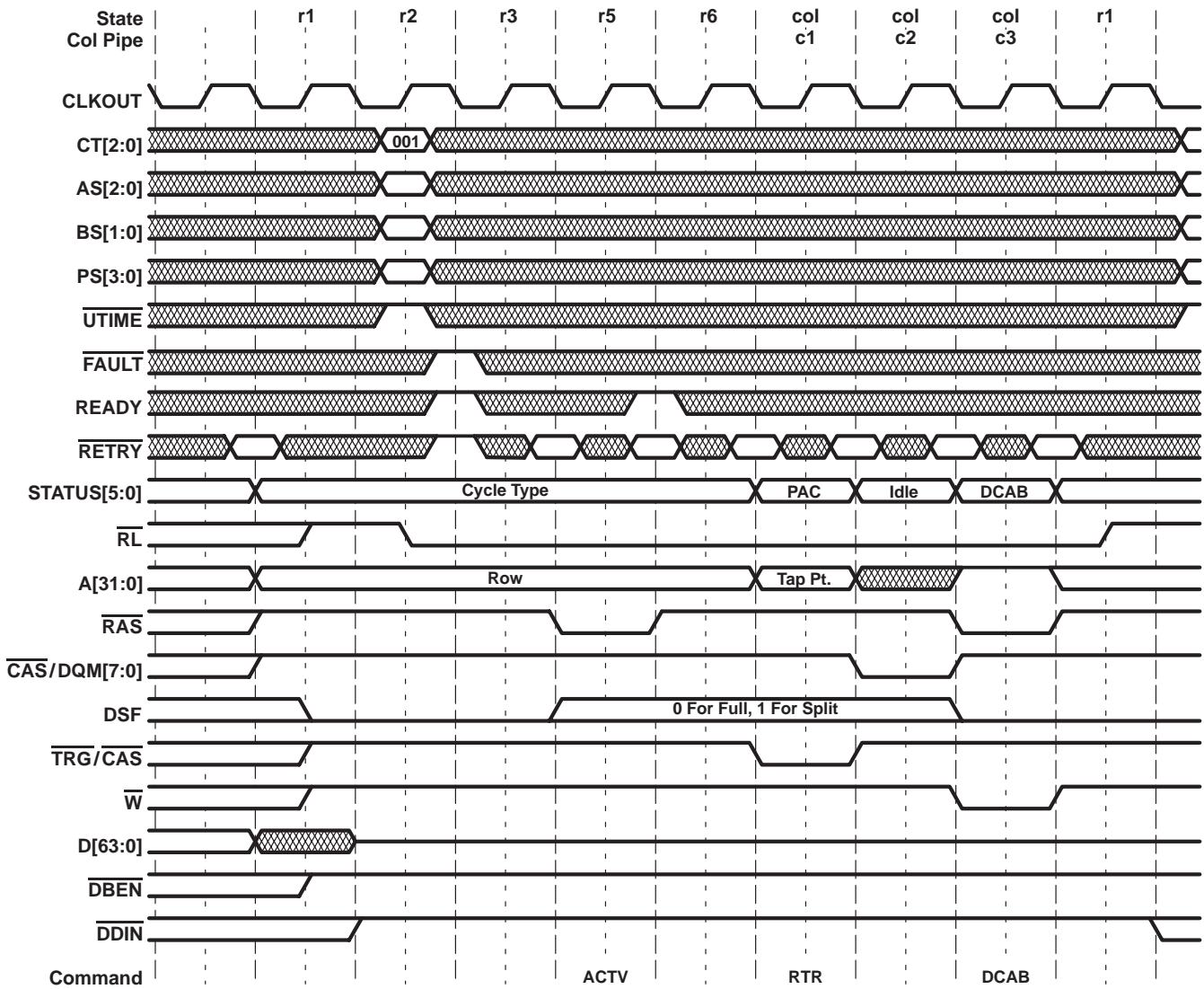

Figure 107. SVRAM Burst-Length 1, 3 Cycle Latency Read-Transfer Cycle Timing

SVRAM transfer cycles (continued)

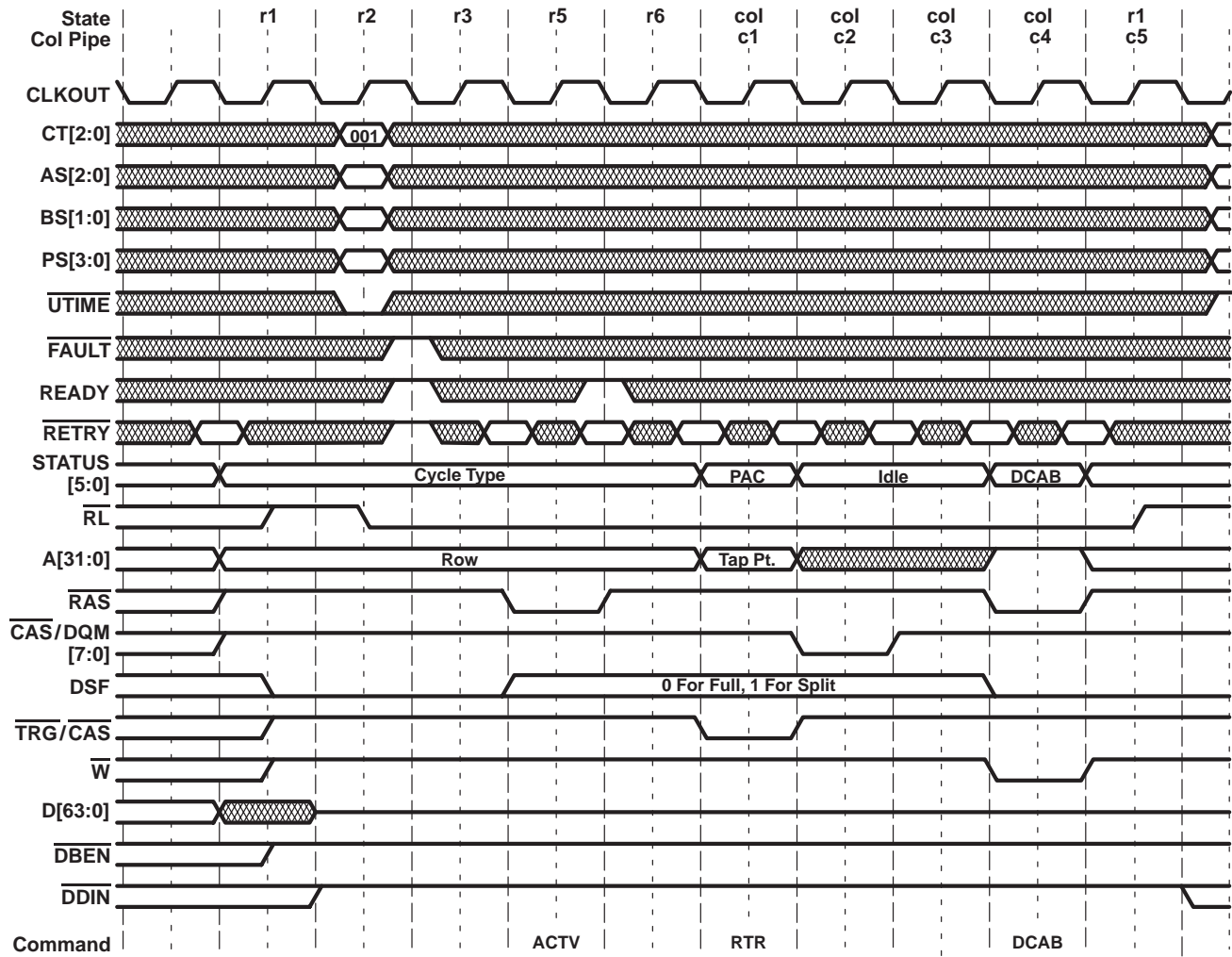

Figure 108. SVRAM Burst-Length 1, 4 Cycle Latency Read-Transfer Cycle Timing

# TMS320C80 DIGITAL SIGNAL PROCESSOR

SPRS023B – JULY 1994 – REVISED OCTOBER 1997

## SVRAM transfer cycles (continued)

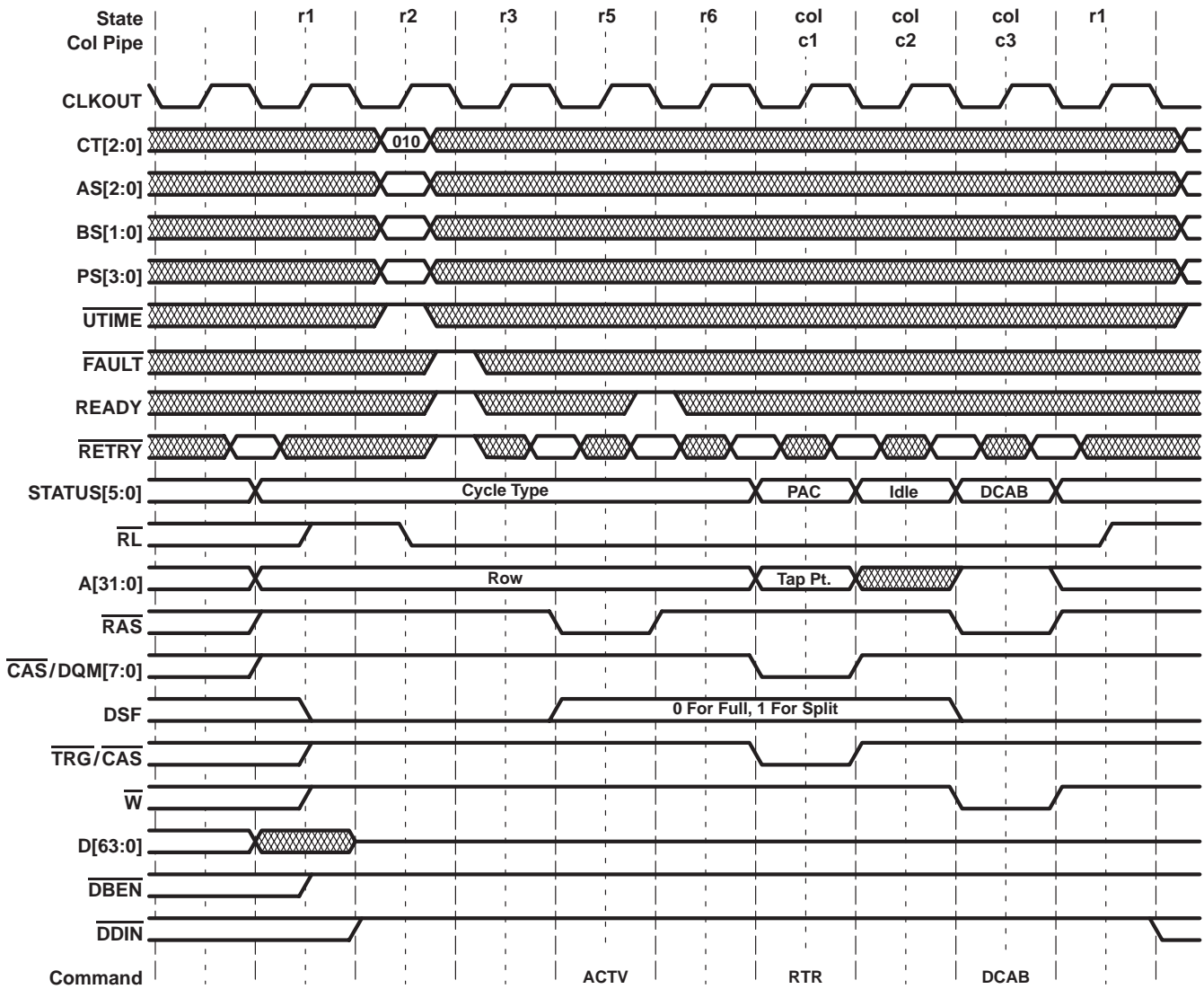

Figure 109. SVRAM Burst-Length 2, 2 Cycle Latency Read-Transfer Cycle Timing

SVRAM transfer cycles (continued)

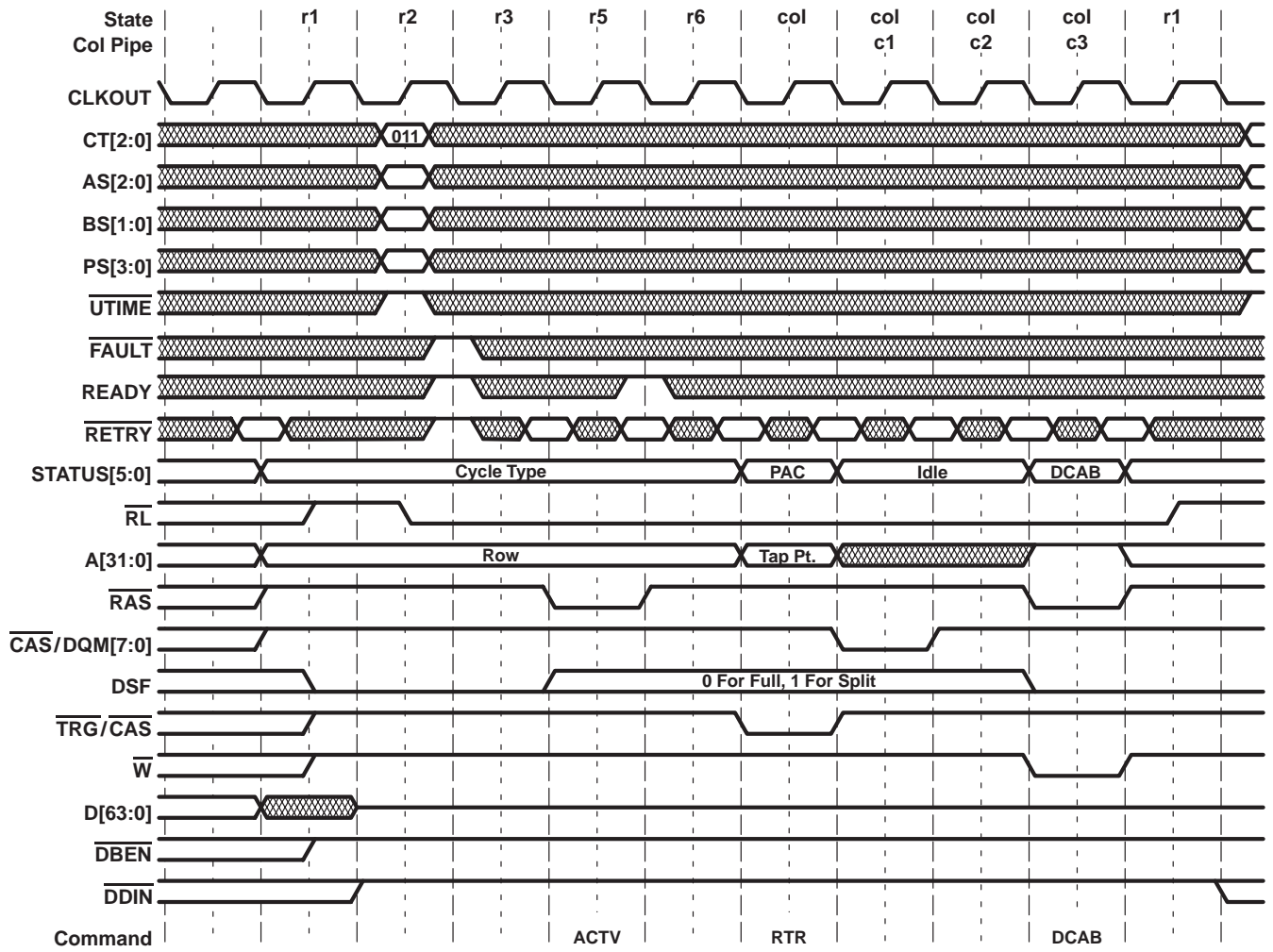

Figure 110. SVRAM Burst-Length 2, 3 Cycle Latency Read-Transfer Cycle Timing

# TMS320C80 DIGITAL SIGNAL PROCESSOR

SPRS023B – JULY 1994 – REVISED OCTOBER 1997

## SVRAM transfer cycles (continued)

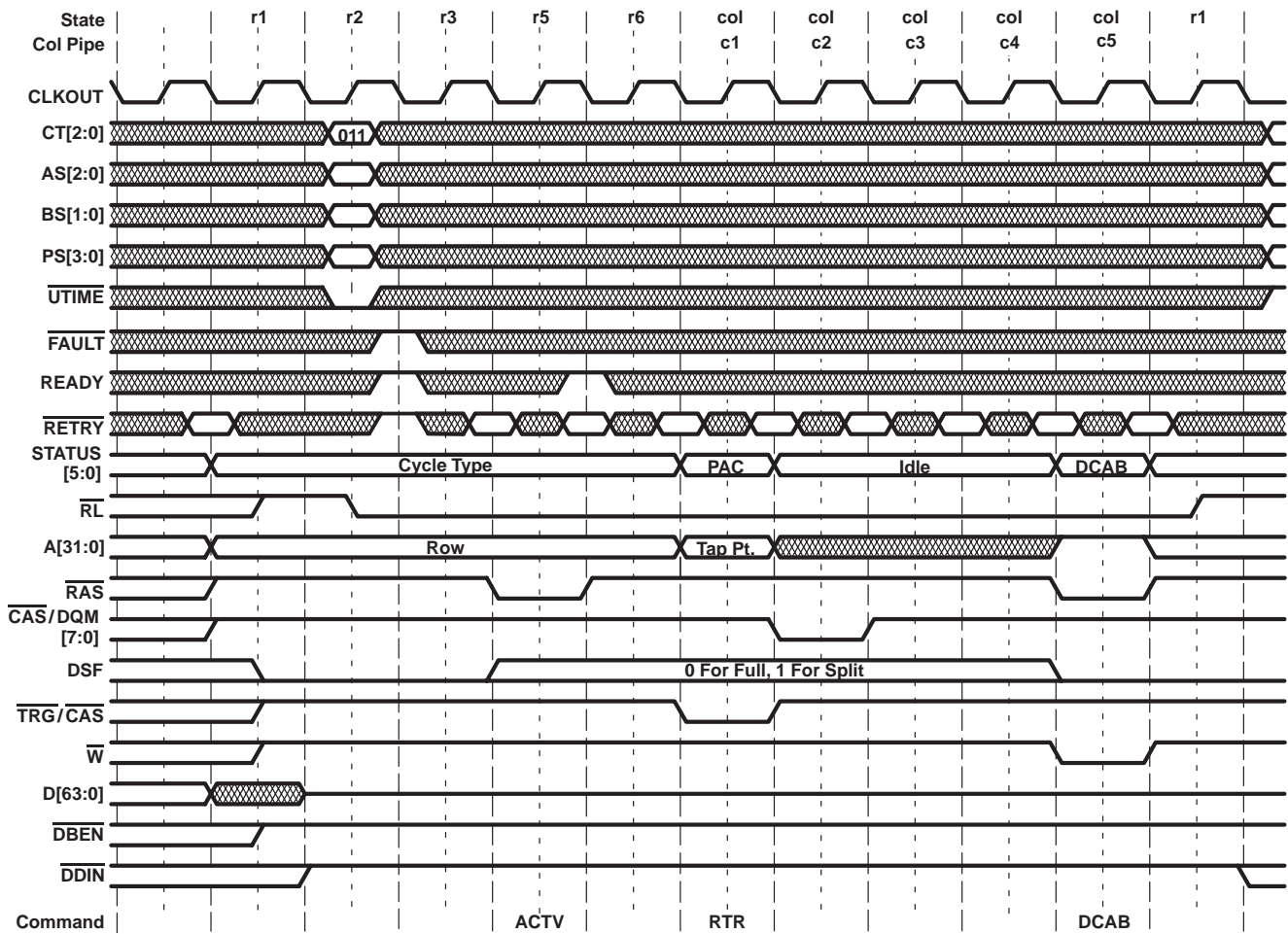

Figure 111. SVRAM Burst-Length 2, 4 Cycle Latency Read-Transfer Cycle Timing

SVRAM transfer cycles (continued)

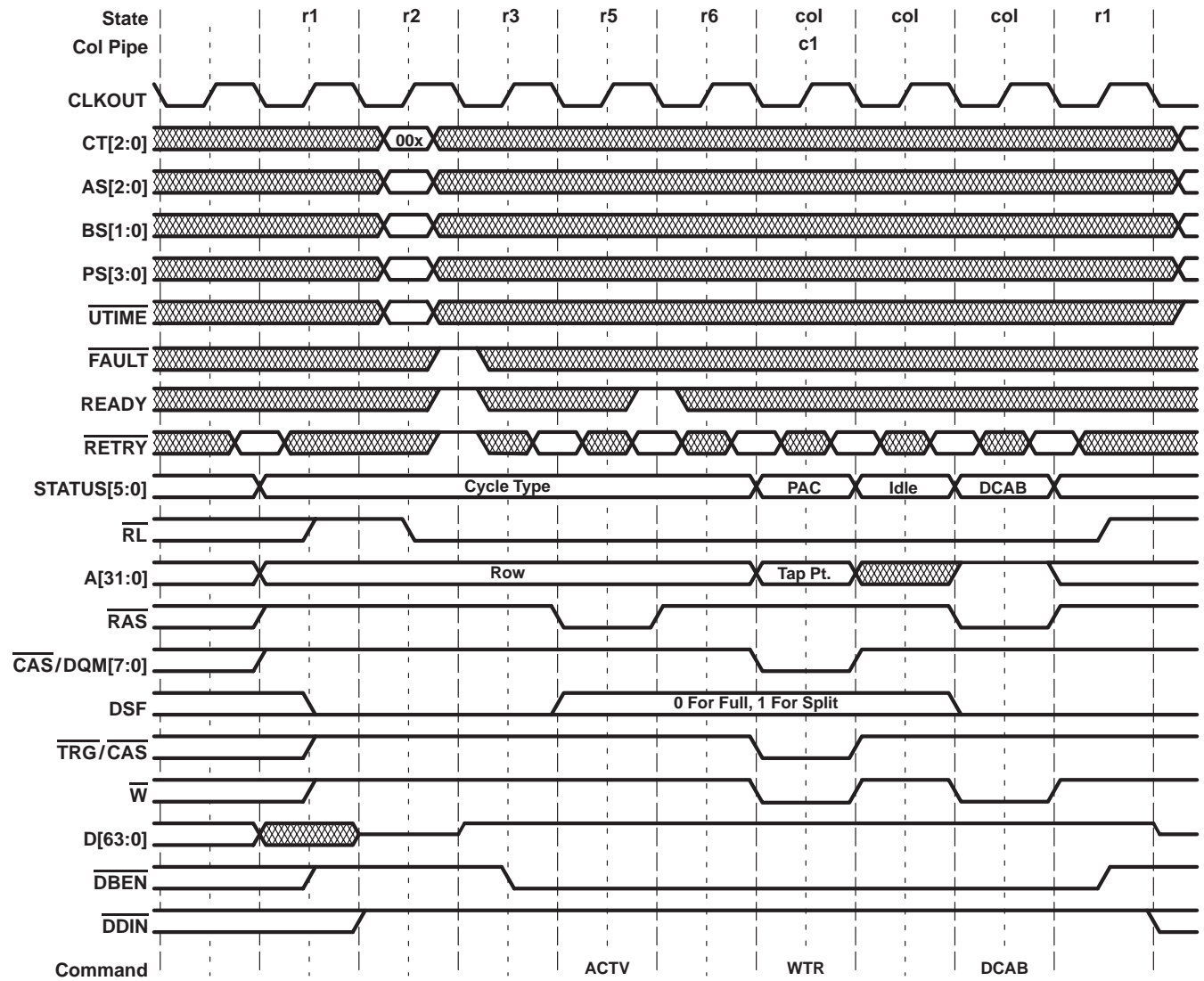
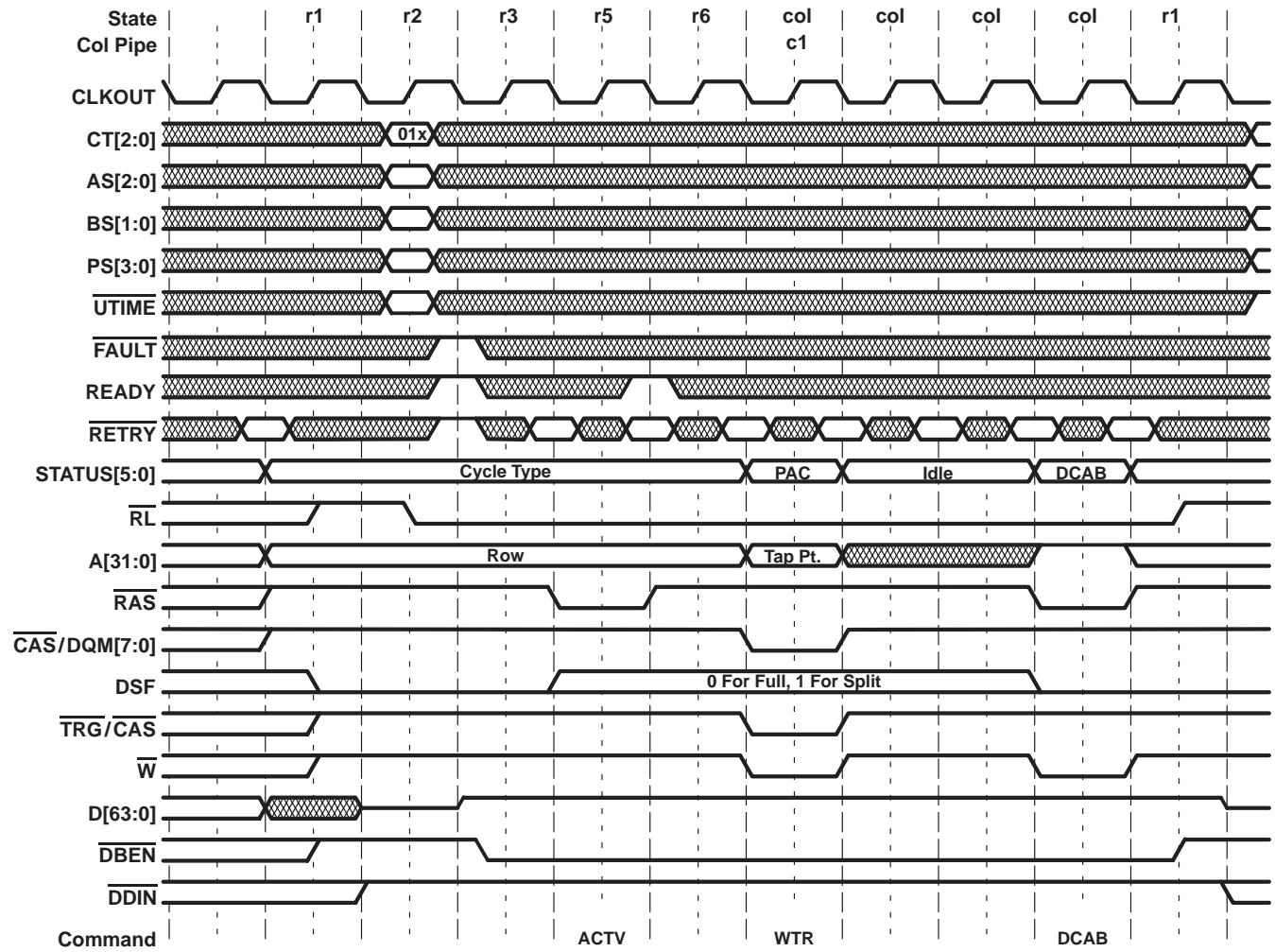

Figure 112. SVRAM Burst-Length 1, Write-Transfer Cycle Timing

**SVRAM transfer cycles (continued)**



**Figure 113. SVRAM Burst-Length 2, Write-Transfer Cycle Timing**

**SDRAM refresh cycle**

The SDRAM refresh cycle is performed when the TC receives an SDRAM-cycle timing input (CT=0xx) at the start of a refresh cycle. The RAS and TRG/CAS outputs are driven low for one cycle to strobe a refresh command (REFR) into the SDRAM. The refresh address is generated internal to the SDRAM. The 'C80 outputs a 16-bit pseudo-address (used for refresh bank decode) on A[31:16] and drives A[15:0] low (see Figure 114).

SDRAM refresh cycle (continued)

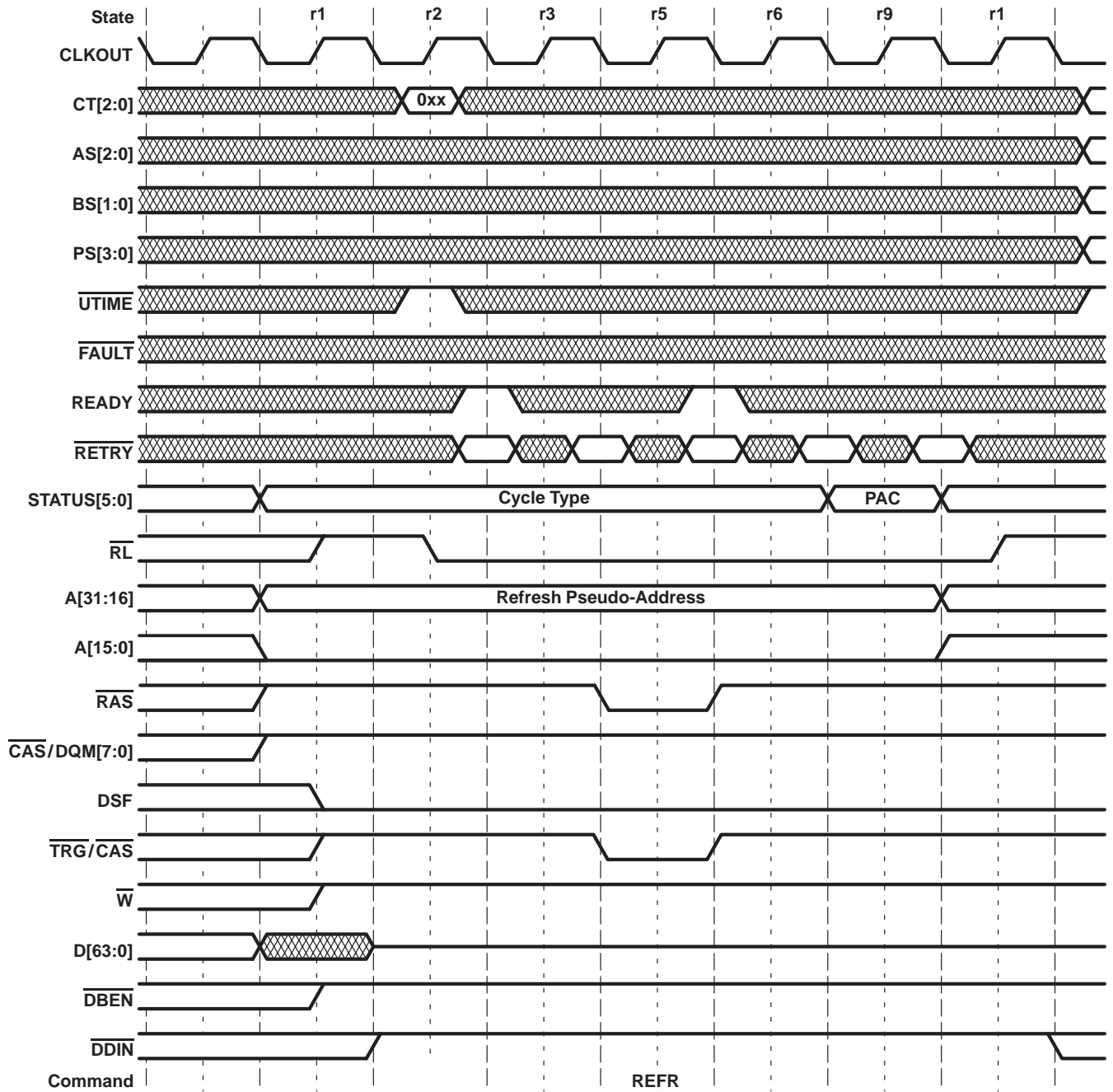

Figure 114. SDRAM Refresh-Cycle Timing

**host interface**

The 'C80 contains a simple four-pin mechanism by which a host or another device can gain control of the 'C80 local memory bus. The  $\overline{\text{HREQ}}$  input can be driven low by the host to request the 'C80's bus. Once the TC has completed the current memory access, it places the local bus (except CLKOUT) into a high-impedance state. It then drives the  $\overline{\text{HACK}}$  output low to indicate that the host device owns the bus and can drive it. The REQ[1:0] outputs reflect the highest priority cycle request being received internally by the TC. The host can monitor these outputs to determine if it needs to relinquish the local bus back to the 'C80 (see Table 37).

**Table 37. TC Priority Cycles**

| REQ[1:0] | ASSOCIATED INTERNAL TC REQUEST                      |
|----------|---|
| 11       | SRT, urgent refresh, XPT, or VCPT                   |
| 10       | Cache/DEA request, urgent packet transfer           |
| 01       | High-priority packet transfer                       |
| 00       | Low-priority packet transfer, trickle refresh, idle |

**device reset**

The TMS320C80 is reset when the  $\overline{\text{RESET}}$  input is driven low. The 'C80 outputs immediately go into a high-impedance state with the exception of CLKOUT,  $\overline{\text{HACK}}$ , and REQ[1:0]. While  $\overline{\text{RESET}}$  is low, all internal registers are set to their default values and internal logic is reset.

On the rising edge of  $\overline{\text{RESET}}$ , the state of  $\overline{\text{UTIME}}$  is sampled to determine if big-endian ( $\overline{\text{UTIME}} = 0$ ) or little-endian ( $\overline{\text{UTIME}} = 1$ ) operation is selected. Also on the rising edge of  $\overline{\text{RESET}}$ , the state of  $\overline{\text{HREQ}}$  is sampled to determine if the master processor comes up running ( $\overline{\text{HREQ}} = 0$ ) or halted ( $\overline{\text{HREQ}} = 1$ ).

Once  $\overline{\text{RESET}}$  is high, the 'C80 drives the high-impedance signals to their inactive values. The TC then performs 32 refresh cycles to initialize system memory. If, during initialization refresh, the TC receives an SDRAM cycle timing code (CT = 0xx), it performs an SDRAM DCAB cycle and a MRS cycle to initialize the SDRAM, and then continues the refresh cycles.

After completing initialization refresh, if the MP is running, the TC performs its instruction-cache-fill request to fetch the cache block beginning at 0xFFFFFC0. This block contains the starting MP instruction located at 0xFFFFFFF8. If the MP comes up halted, the instruction cache fill does not take place until the first occurrence of an  $\overline{\text{EINT3}}$  interrupt to unhalt the MP.



**absolute maximum ratings over specified temperature ranges (unless otherwise noted)†**

|   |                 |
|---|-----------------|
| Supply voltage range, $V_{DD}$ (see Note 1) | – 0.3 V to 4 V  |
| Input voltage range, $V_I$                  | – 0.3 V to 4 V  |
| Output voltage range                        | – 0.3 V to 4 V  |
| Operating case temperature range, $T_C$     | 0°C to 85°C     |
| Storage temperature range, $T_{Stg}$        | – 55°C to 150°C |

† Stresses beyond those listed under “absolute maximum ratings” may cause permanent damage to the device. These are stress ratings only, and functional operation of the device at these or any other conditions beyond those indicated under “recommended operating conditions” is not implied. Exposure to absolute-maximum-rated conditions for extended periods may affect device reliability.

NOTE 1: All voltage values are with respect to  $V_{SS}$ .

**recommended operating conditions**

|                                      | MIN   | NOM | MAX   | UNIT |
|--------------------------------------|-------|-----|-------|------|
| $V_{DD}$ Supply voltage              | 3.135 | 3.3 | 3.465 | V    |
| $V_{SS}$ Supply voltage (see Note 2) |       | 0   |       | V    |
| $I_{OH}$ High-level output current   |       |     | – 400 | μA   |
| $I_{OL}$ Low-level output current    |       |     | 2     | mA   |
| $T_C$ Operating case temperature     | 0     |     | 85    | °C   |

NOTE 2: In order to minimize noise on  $V_{SS}$ , care should be taken to provide a minimum inductance path between the  $V_{SS}$  pins and system ground.

**electrical characteristics over recommended ranges of supply voltage and operating case temperature (unless otherwise noted)**

| PARAMETER   | TEST CONDITIONS‡                           | MIN   | TYP§           | MAX  | UNIT |
|---|--|-------|----------------|------|------|
| $V_{IH}$ High-level input voltage                                     |  | 2     | $V_{DD} + 0.3$ |      | V    |
| $V_{IL}$ Low-level input voltage                                      |  | – 0.3 |                | 0.8  | V    |
| $V_{OH}$ High-level output voltage                                    | $V_{DD} = \text{MIN}, I_{OH} = \text{MAX}$ | 2.6   | †              |      | V    |
| $V_{OL}$ Low-level output voltage                                     | $V_{DD} = \text{MAX}, I_{OH} = \text{MIN}$ |       |                | 0.6  | V    |
| $I_O$ Output current, leakage (high impedance) (except EMU0 and EMU1) | $V_{DD} = \text{MAX}, V_O = 2.8 \text{ V}$ |       |                | 20   | μA   |
|   | $V_{DD} = \text{MAX}, V_O = 0.6 \text{ V}$ |       |                | – 20 |      |
| $I_I$ Input current (except TCK, TDI, and TMS)                        | $V_I = V_{SS} \text{ to } V_{DD}$          |       |                | ±20  | μA   |
| $I_{DD}$ Supply current (see Note 3)                                  | $V_{DD} = \text{MAX}, 60 \text{ MHz}$      |       | 1.2#           | 2.5# | A    |
|   | $V_{DD} = \text{MAX}, 50 \text{ MHz}$      |       | 1.0#           | 2.3# |      |
|   | $V_{DD} = \text{MAX}, 40 \text{ MHz}$      |       | 0.9#           | 1.9# |      |
| $C_i$ Input capacitance   |  |       | 10             |      | pF   |
| $C_o$ Output capacitance  |  |       | 10             |      | pF   |

‡ For conditions shown as MIN/MAX, use the appropriate value specified under the recommended operating conditions.

§ All typical values are at  $V_{DD} = 3.3 \text{ V}$ , ambient air temperature = 25°C

† Typical steady-state  $V_{OH}$  will not exceed  $V_{DD}$

# Parameter value is representative of revision 4.x and higher devices.

NOTE 3: Maximum supply current is derived from a test case that generates the theoretical maximum data flow using a worst case checkerboard data pattern on a sustained cycle by cycle basis. Actual maximum  $I_{DD}$  varies in real applications based on internal and external data flow and transitions. Typical supply current is derived from a test case which attempts to emulate typical use conditions of the on-chip processors with random data. Typical  $I_{DD}$  varies from application to application based on data flow and transitions and on-chip processor utilization.

PARAMETER MEASUREMENT INFORMATION

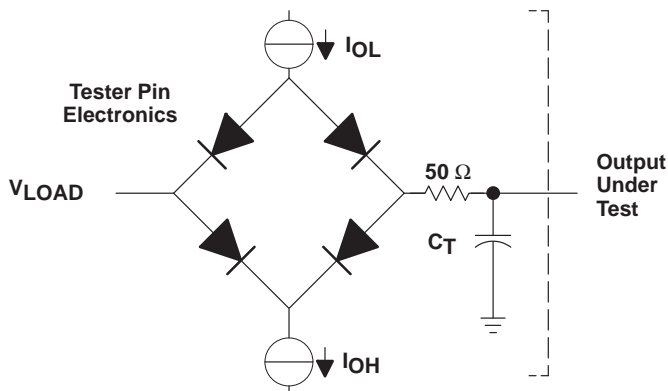

Where:  $I_{OL}$  = 2.0 mA (all outputs)  
 $I_{OH}$  = 400  $\mu$ A (all outputs)  
 $V_{LOAD}$  = 1.5 V  
 $C_T$  = 60 pF typical load circuit capacitance

Figure 115. Test Load Circuit

signal transition levels

TTL-output levels are driven to a minimum logic-high level of 2.4 V and to a maximum logic-low level of 0.6 V. Figure 116 shows the TTL-level outputs.

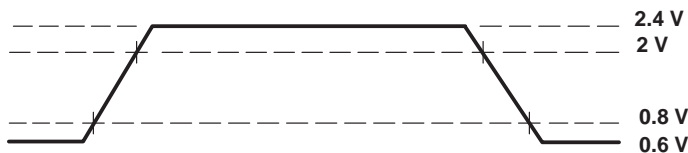

Figure 116. TTL-Level Outputs

TTL-output transition times are specified as follows:

- For a high-to-low transition, the level at which the output is said to be no longer high is 2 V, and the level at which the output is said to be low is 0.8 V.
- For a low-to-high transition, the level at which the output is said to be no longer low is 0.8 V, and the level at which the output is said to be high is 2 V.

Figure 117 shows the TTL-level inputs.

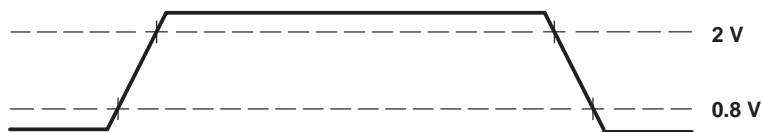

Figure 117. TTL-Level Inputs

TTL-compatible input transition times are specified as follows:

- For a high-to-low transition on an input signal, the level at which the input is said to be no longer high is 2 V, and the level at which the input is said to be low is 0.8 V.
- For a low-to-high transition on an input signal, the level at which the input is said to be no longer low is 0.8 V, and the level at which the input is said to be high is 2 V.

## PARAMETER MEASUREMENT INFORMATION

### timing parameter symbology

Timing parameter symbols used herein were created in accordance with JEDEC Standard 100-A. In order to shorten the symbols, some of the pin names and other related terminology have been abbreviated as follows:

|     |   |     |  |
|-----|---|-----|--|
| A   | A[31:0]   | RDY | READY  |
| CAS | $\overline{\text{CAS}}/\text{DQM}[7:0]$   | RST | $\overline{\text{RESET}}$  |
| CFG | AS[2:0], BS[1:0], CT[2:0], PS[3:0], $\overline{\text{UTIME}}$   | RTY | $\overline{\text{RETRY}}$  |
| CKI | CLKIN   | REQ | REQ[1:0]   |
| CKO | CLKOUT  | RL  | $\overline{\text{RL}}$   |
| CMP | $\overline{\text{RETRY}}$ , READY, $\overline{\text{FAULT}}$  | RR  | READY, $\overline{\text{RETRY}}$   |
| D   | D[63:0]   | SCK | SCLK0, SCLK1   |
| EIN | $\overline{\text{EINT1}}$ , $\overline{\text{EINT2}}$ , $\overline{\text{EINT3}}$ , or EINTx  | TCK | TCK  |
| EMU | EMU0, EMU1  | TDI | TDI  |
| FCK | FCLK0, FCLK1  | TDO | TDO  |
| HAK | $\overline{\text{HACK}}$  | TMS | TMS  |
| HRQ | $\overline{\text{HREQ}}$  | TRS | $\overline{\text{TRST}}$   |
| LIN | $\overline{\text{LINT4}}$   | UTM | $\overline{\text{UTIME}}$  |
| MID | A[31:0], STATUS[5:0]  | SI  | $\overline{\text{HSYNC0}}$ , $\overline{\text{VSYNC0}}$ , $\overline{\text{CSYNC0}}$ , $\overline{\text{HSYNC1}}$ , $\overline{\text{VSYNC1}}$ ,<br>or $\overline{\text{CSYNC1}}$  |
| OUT | A[31:0], $\overline{\text{CAS}}/\text{DQM}[7:0]$ , D[63:0], $\overline{\text{DBEN}}$ , $\overline{\text{DDIN}}$ ,<br>DSF, RAS, $\overline{\text{RL}}$ , STATUS[5:0], $\overline{\text{TRG}}/\text{CAS}$ , W | SY  | $\overline{\text{HSYNC0}}$ , $\overline{\text{VSYNC0}}$ , $\overline{\text{CSYNC0}}/\text{HBLNK0}$ ,<br>$\overline{\text{CBLNK0}}/\text{VBLNK0}$ , $\overline{\text{HSYNC1}}$ , $\overline{\text{VSYNC1}}$ ,<br>$\overline{\text{CSYNC1}}/\text{HBLNK1}$ , $\overline{\text{CBLNK1}}/\text{VBLNK1}$ , CAREA0,<br>or CAREA1 |
| RAS | $\overline{\text{RAS}}$   | XPT | $\overline{\text{XPT}}[2:0]$ OR $\overline{\text{XPTx}}$   |

Lowercase subscripts and their meanings are:

|    |                        |
|----|------------------------|
| a  | access time            |
| c  | cycle time (period)    |
| d  | delay time             |
| h  | hold time              |
| su | setup time             |
| t  | transition time        |
| w  | pulse duration (width) |

The following letters and symbols and their meanings are:

|   |  |
|---|--|
| H | High                                   |
| L | Low                                    |
| V | Valid                                  |
| Z | High impedance                         |
| X | Unknown, changing, or don't care level |

### general notes on timing parameters

The period of the output clock (CLKOUT) is twice the period of the input clock (CLKIN), or  $2 \times t_{c(\text{CKI})}$ . The half cycle time ( $t_H$ ) that appears in the following tables is one-half of the output clock period, or equal to the input clock period,  $t_{c(\text{CKI})}$ .

All output signals from the 'C80 (including CLKOUT) are derived from an internal clock such that all output transitions for a given half cycle occur with a minimum of skewing relative to each other.

The signal combinations shown in the following timing diagrams may not necessarily represent actual cycles. For actual cycle examples, refer to the appropriate cycle description section of this data sheet.

# TMS320C80 DIGITAL SIGNAL PROCESSOR

SPRS023B – JULY 1994 – REVISED OCTOBER 1997

## CLKIN timing requirements (see Figure 118)

| NO. |   | 'C80-40 |     | 'C80-50 |     | 'C80-60 |     | UNIT |
|-----|---|---------|-----|---------|-----|---------|-----|------|
|     |   | MIN     | MAX | MIN     | MAX | MIN     | MAX |      |
| 1   | $t_c(\text{CKI})$ Period of CLKIN ( $t_H$ )     | 12.5    |     | 10      |     | 8.3     |     | ns   |
| 2   | $t_w(\text{CKIH})$ Pulse duration of CLKIN high | 4.8     |     | 4.2     |     | 3.9     |     | ns   |
| 3   | $t_w(\text{CKIL})$ Pulse duration of CLKIN low  | 4.8     |     | 4.2     |     | 3.9     |     | ns   |
| 4   | $t_t(\text{CKI})$ Transition time of CLKIN†     |         | 1.5 |         | 1.5 |         | 1.5 | ns   |

† This parameter is verified by computer simulation and is not tested.

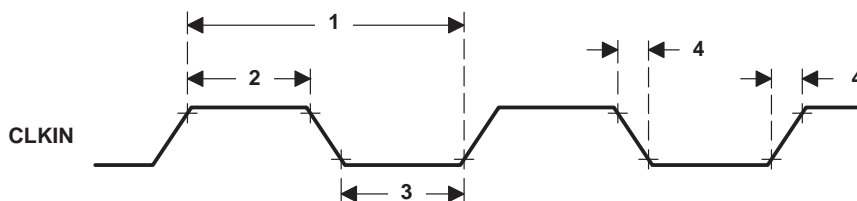

Figure 118. CLKIN Timing

## local-bus switching characteristics over full operating range: CLKOUT‡(see Figure 119)

| NO. | PARAMETER  | 'C80-40              |     | 'C80-50              |     | 'C80-60              |     | UNIT |
|-----|--|----------------------|-----|----------------------|-----|----------------------|-----|------|
|     |  | MIN                  | MAX | MIN                  | MAX | MIN                  | MAX |      |
| 5   | $t_c(\text{CKO})$ Period of CLKOUT               | $2t_c(\text{CKI})$ § |     | $2t_c(\text{CKI})$ § |     | $2t_c(\text{CKI})$ § |     | ns   |
| 6   | $t_w(\text{CKOH})$ Pulse duration of CLKOUT high | $t_H - 5.5$          |     | $t_H - 4.5$          |     | $t_H - 3.7$          |     | ns   |
| 7   | $t_w(\text{CKOL})$ Pulse duration of CLKOUT low  | $t_H - 5.5$          |     | $t_H - 4.5$          |     | $t_H - 3.7$          |     | ns   |
| 8   | $t_t(\text{CKO})$ Transition time of CLKOUT      | $2$ ¶                |     | $2$ ¶                |     | $2$ ¶                |     | ns   |

‡ The CLKOUT output has twice the period of CLKIN. No propagation delay or phase relationship to CLKIN is assured. Each state of a memory access begins on the falling edge of CLKOUT.

§ This is a functional minimum and is not tested. This parameter may also be specified as  $2t_H$ .

¶ This parameter is verified by computer simulation and is not tested.

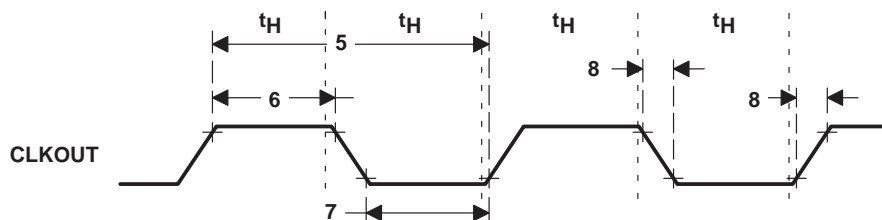

Figure 119. CLKOUT Timing

device reset timing requirements (see Figure 120)

| NO. |  |   | MIN                           | MAX    | UNIT |
|-----|--|---|-------------------------------|--------|------|
| 9   | $t_w(\overline{\text{RSTL}})$                | Pulse duration, $\overline{\text{RESET}}$ low   | Initial reset during power-up | $6t_h$ | ns   |
|     |  |   | Reset during active operation | $6t_h$ | ns   |
| 10  | $t_{su}(\overline{\text{HRQL}}\text{-RSTH})$ | Setup time of $\overline{\text{HREQ}}$ low to $\overline{\text{RESET}}$ high to configure self-bootstrap mode   | $4t_h$                        |        | ns   |
| 11  | $t_h(\text{RSTH-}\overline{\text{HRQL}})$    | Hold time, $\overline{\text{HREQ}}$ low after $\overline{\text{RESET}}$ high to configure self-bootstrap mode   | 0                             |        | ns   |
| 12  | $t_{su}(\overline{\text{UTML}}\text{-RSTH})$ | Setup time of $\overline{\text{UTIME}}$ low to $\overline{\text{RESET}}$ high to configure big-endian operation | $4t_h$                        |        | ns   |
| 13  | $t_h(\text{RSTH-}\overline{\text{UTML}})$    | Hold time, $\overline{\text{UTIME}}$ low after $\overline{\text{RESET}}$ high to configure big-endian operation | 0                             |        | ns   |

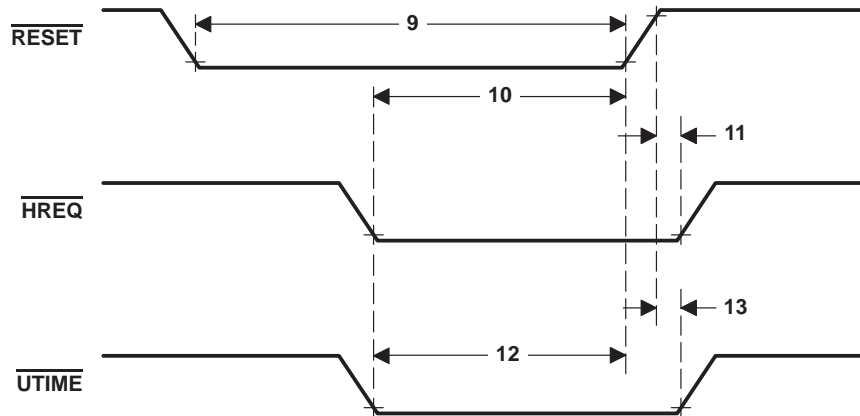
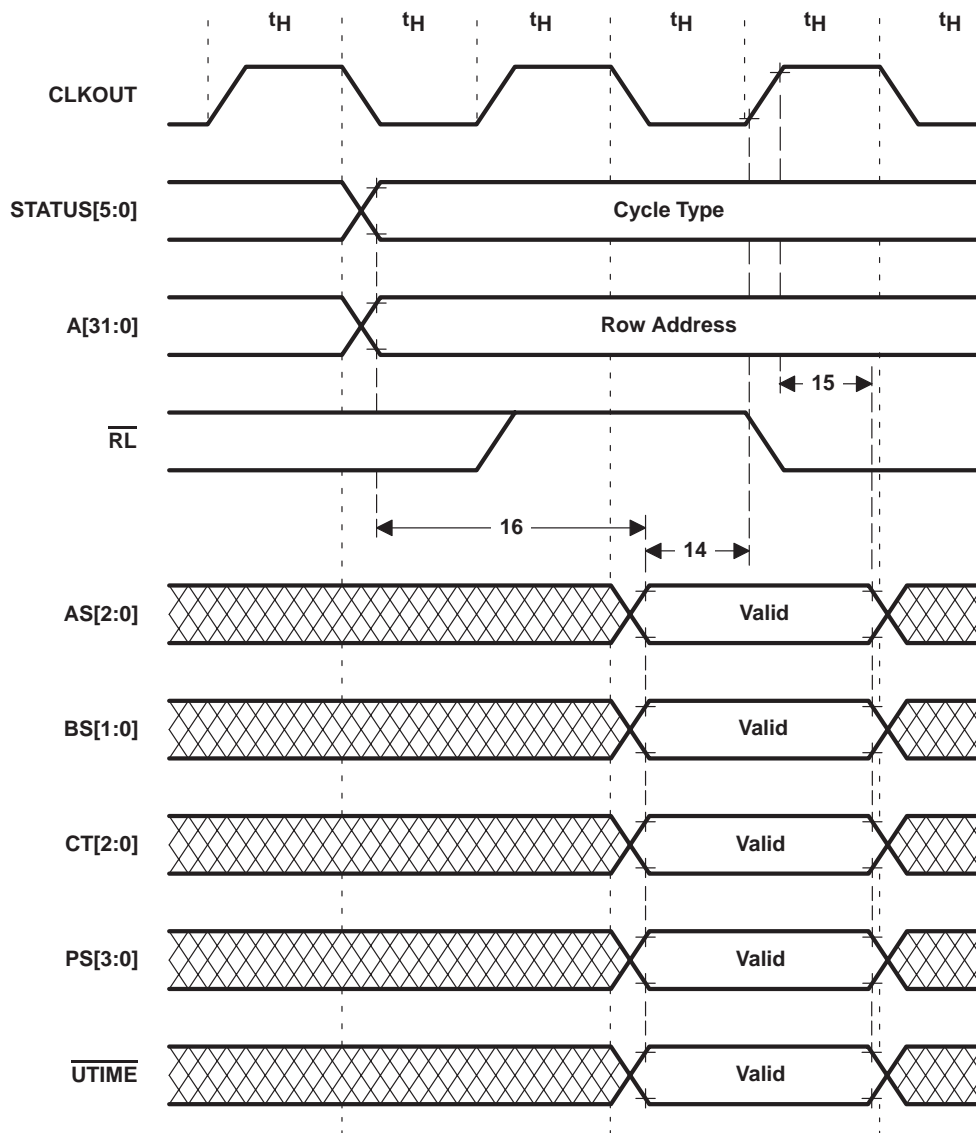

Figure 120. Device-Reset Timing

**local bus timing requirements: cycle configuration inputs (see Figure 121)**

The cycle configuration inputs are sampled at the beginning of each row access during the r2 state. The inputs typically are generated by a static decode of the A[31:0] and STATUS[5:0] outputs.

| NO. |  | MIN         | MAX | UNIT |
|-----|--|-------------|-----|------|
| 14  | $t_{su}(CFGV-CKOH)$ Setup time, AS, BS, CT, PS, and $\overline{UTIME}$ valid to CLKOUT no longer low                     | 8           |     | ns   |
| 15  | $t_h(CKOH-CFGV)$ Hold time, AS, BS, CT, PS, and $\overline{UTIME}$ valid after CLKOUT high                               | 2           |     | ns   |
| 16  | $t_a(MIDV-CFGV)$ Access time, AS, BS, CT, PS, and $\overline{UTIME}$ valid after memory identification (A, STATUS) valid | $3t_H - 10$ |     | ns   |



**Figure 121. Local Bus Timing: Cycle Configuration Inputs**

**local bus timing: cycle completion inputs (see Figure 122 and Figure 123)**

The cycle completion inputs are sampled at the beginning of each row access at the start of the r3 state. The READY input is also sampled at the start of the r6 state and during each column access (2 and 3 cyc/col accesses only). The  $\overline{\text{RETRY}}$  input is sampled on each CLKOUT falling edge following r3. The value  $n$  as used in the parameters represents the integral number of half cycles between the transitions of the two signals in question.

| NO. |  | 'C80-40            |            | 'C80-50 |            | 'C80-60 |            | UNIT |
|-----|--|--------------------|------------|---------|------------|---------|------------|------|
|     |  | MIN                | MAX        | MIN     | MAX        | MIN     | MAX        |      |
| 17  | $t_{a(\text{MIDV-CMPV})}$ Access time, $\overline{\text{RETRY}}$ , $\overline{\text{READY}}$ , $\overline{\text{FAULT}}$ valid after memory identification (A, STATUS) valid |                    | $nt_H-9$   |         | $nt_H-8$   |         | $nt_H-7$   | ns   |
| 18  | $t_{su(\text{CMPV-CKOL})}$ Setup time, $\overline{\text{RETRY}}$ , $\overline{\text{READY}}$ , $\overline{\text{FAULT}}$ valid to CLKOUT no longer high                      | 8.0                |            | 7.5     |            | 7.5     |            | ns   |
| 19  | $t_h(\text{CKOL-CMPV})$ Hold time, $\overline{\text{RETRY}}$ , $\overline{\text{READY}}$ , $\overline{\text{FAULT}}$ valid after CLKOUT low                                  | 1.2                |            | 1.2     |            | 1.2     |            | ns   |
| 20  | $t_{a(\text{RASL-RRV})}$ Access time $\overline{\text{RETRY}}$ , $\overline{\text{READY}}$ valid from $\overline{\text{RAS}}$ low  |                    | $nt_H-8$   |         | $nt_H-7.5$ |         | $nt_H-7.5$ | ns   |
| 21  | $t_{a(\text{RLL-RRV})}$ Access time, $\overline{\text{RETRY}}$ , $\overline{\text{READY}}$ valid from $\overline{\text{RL}}$ low   |                    | $nt_H-8$   |         | $nt_H-7.5$ |         | $nt_H-7.5$ | ns   |
| 22  | $t_{a(\text{CASL-RRV})}$ Access time, $\overline{\text{READY}}$ valid from $\overline{\text{CAS}}$ low (non-usertime mode)   | 2 cyc/col accesses | $t_H-13.5$ |         | $t_H-12$   |         | $t_H-12$   | ns   |
|     |  | 3 cyc/col accesses | $2t_H-9$   |         | $2t_H-8$   |         | $2t_H-7$   |      |

local bus timing: cycle completion inputs (continued)

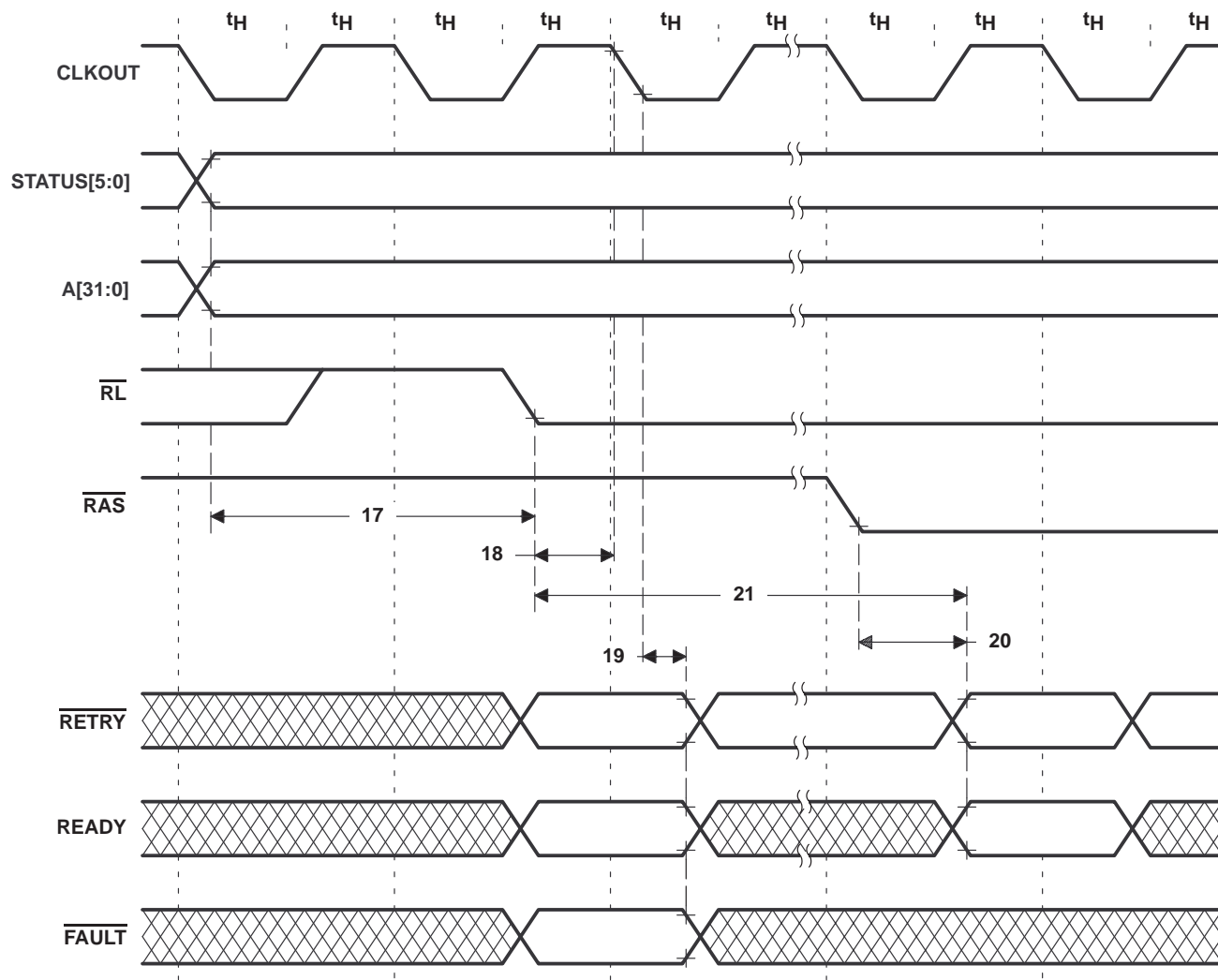

Figure 122. Local Bus Timing: Row-Time Cycle Completion Inputs

local bus timing: cycle completion inputs (continued)

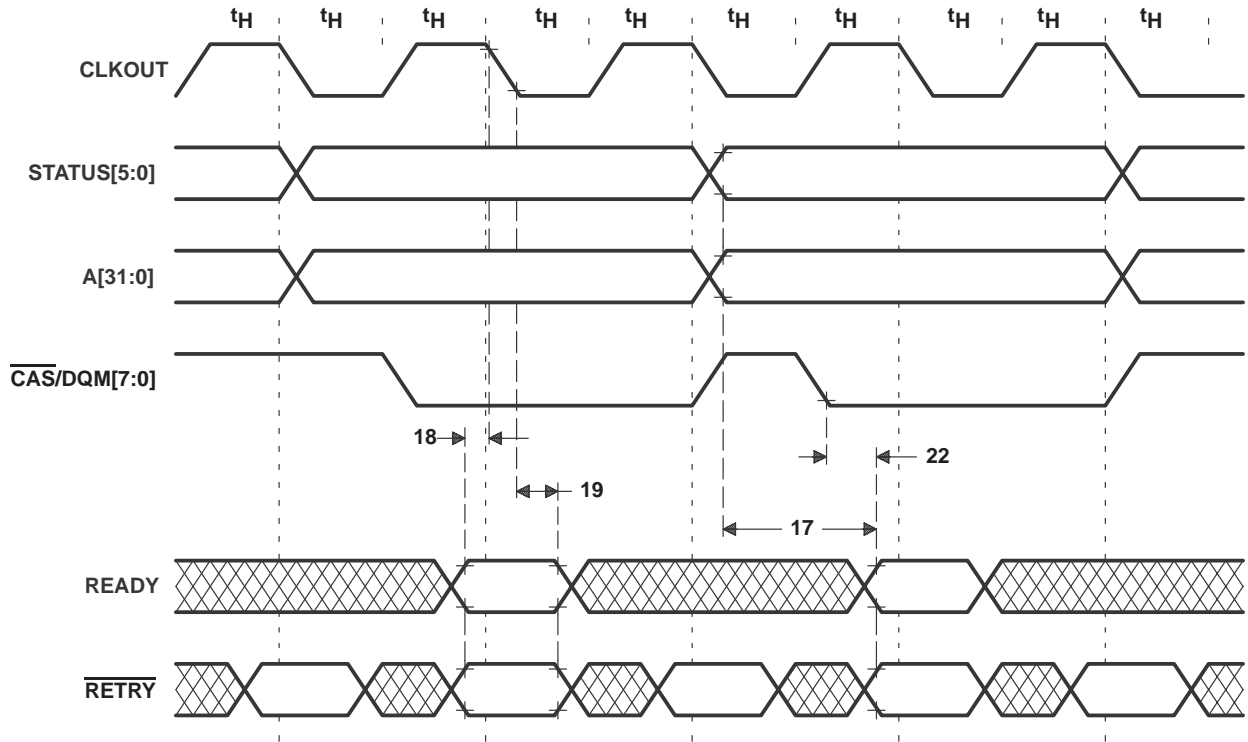

Figure 123. Local Bus Timing: Column-Time Cycle Completion Inputs

# TMS320C80

## DIGITAL SIGNAL PROCESSOR

SPRS023B – JULY 1994 – REVISED OCTOBER 1997

---

### general output signal characteristics over full range of operating conditions

The following general timing parameters apply to all TMS320C80 output signals unless otherwise specifically given. The value  $n$  as used in the parameters represents the integral number of half cycles between the transitions of the two outputs in question. For timing purposes, outputs fall into one of three groups – the data bus ( $D[63:0]$ ); the other output buses ( $A[31:0]$ ,  $STATUS[5:0]$ ,  $\overline{CAS}/DQM[7:0]$ ); and non-bus outputs ( $\overline{DBEN}$ ,  $\overline{DDIN}$ ,  $DSF$ ,  $RAS$ ,  $\overline{RL}$ ,  $\overline{TRG}/\overline{CAS}$ ,  $\overline{W}$ ). When measuring output to output, the named group refers to the first output to transition (output A), and the second output (output B) refers to any output group (see Figure 124).



general output signal characteristics over full range of operating conditions†(continued)

| NO. | PARAMETER  | 'C80-40    |            | 'C80-50    |            | 'C80-60    |            | UNIT |
|-----|--|------------|------------|------------|------------|------------|------------|------|
|     |  | MIN        | MAX        | MIN        | MAX        | MIN        | MAX        |      |
| 23  | $t_{h(OUTV-CKOL)}$<br>Hold time, CLKOUT high after output valid<br>D[63:0]<br>A[31:0], STATUS[5:0],<br>CAS/DQM[7:0]‡<br>DBEN, DDIN, DSF, RAS, RL,<br>TRG/CAS, W        | $nt_H-7$   |            | $nt_H-5.3$ |            | $nt_H-5.3$ |            | ns   |
|     |  | $nt_H-6.5$ |            | $nt_H-4.3$ |            | $nt_H-4.3$ |            |      |
|     |  | $nt_H-5.5$ |            | $nt_H-3.9$ |            | $nt_H-3.9$ |            |      |
| 24  | $t_{h(OUTV-CKOH)}$<br>Hold time, CLKOUT low after output valid<br>D[63:0]<br>A[31:0]<br>STATUS[5:0], CAS/DQM[7:0]‡<br>DBEN, DDIN, DSF, RAS, RL,<br>TRG/CAS, W          | $nt_H-7$   |            | $nt_H-5.5$ |            | $nt_H-4$   |            | ns   |
|     |  | $nt_H-6.5$ |            | $nt_H-4.5$ |            | $nt_H-4$   |            |      |
|     |  | $nt_H-6.5$ |            | $nt_H-4.5$ |            | $nt_H-4.5$ |            |      |
|     |  | $nt_H-5.5$ |            | $nt_H-4.1$ |            | $nt_H-4.1$ |            |      |
| 25  | $t_{h(CKOL-OUTV)}$<br>Hold time, output valid after CLKOUT low   | $nt_H-5.5$ |            | $nt_H-5$   |            | $nt_H-5$   |            | ns   |
| 26  | $t_{h(CKOH-OUTV)}$<br>Hold time, output valid after CLKOUT high  | $nt_H-5.5$ |            | $nt_H-5$   |            | $nt_H-4$   |            | ns   |
| 27  | $t_{h(OUTV-OUTV)}$<br>Hold time, output valid after output valid<br>D[63:0]<br>A[31:0], STATUS[5:0],<br>CAS/DQM[7:0]‡<br>DBEN, DDIN, DSF, RAS, RL,<br>TRG/CAS, W       | $nt_H-7$   |            | $nt_H-6.5$ |            | $nt_H-5.9$ |            | ns   |
|     |  | $nt_H-6.5$ |            | $nt_H-5.5$ |            | $nt_H-5.5$ |            |      |
|     |  | $nt_H-5.5$ |            | $nt_H-5$   |            | $nt_H-4.7$ |            |      |
| 28  | $t_d(CKOH-OUTV)$<br>Delay time, CLKOUT no longer low to output valid<br>D[63:0]<br>A[31:0], STATUS[5:0],<br>CAS/DQM[7:0]‡<br>DBEN, DDIN, DSF, RAS, RL,<br>TRG/CAS, W   |            | $nt_H+7$   |            | $nt_H+6.5$ |            | $nt_H+5.9$ | ns   |
|     |  |            | $nt_H+6.5$ |            | $nt_H+5.5$ |            | $nt_H+5.5$ |      |
|     |  |            | $nt_H+5.5$ |            | $nt_H+5$   |            | $nt_H+4.7$ |      |
| 29  | $t_d(CKOL-OUTV)$<br>Delay time, CLKOUT no longer high to output valid<br>D[63:0]<br>A[31:0], STATUS[5:0],<br>CAS/DQM[7:0]‡<br>DBEN, DDIN, DSF, RAS, RL,<br>TRG/CAS, W  |            | $nt_H+7$   |            | $nt_H+6.5$ |            | $nt_H+5.9$ | ns   |
|     |  |            | $nt_H+6.5$ |            | $nt_H+5.5$ |            | $nt_H+5.5$ |      |
|     |  |            | $nt_H+5.5$ |            | $nt_H+5$   |            | $nt_H+4.7$ |      |
| 30  | $t_d(OUTV-CKOH)$<br>Delay time, output no longer valid to CLKOUT high  |            | $nt_H+5.5$ |            | $nt_H+5$   |            | $nt_H+5$   | ns   |
| 31  | $t_d(OUTV-CKOL)$<br>Delay time, output no longer valid to CLKOUT low   |            | $nt_H+5.5$ |            | $nt_H+5$   |            | $nt_H+5$   | ns   |
| 32  | $t_d(OUTV-OUTV)$<br>Delay time, output no longer valid to output valid<br>D[63:0]<br>A[31:0], STATUS[5:0],<br>CAS/DQM[7:0]‡<br>DBEN, DDIN, DSF, RAS, RL,<br>TRG/CAS, W |            | $nt_H+7$   |            | $nt_H+6.5$ |            | $nt_H+6.1$ | ns   |
|     |  |            | $nt_H+6.5$ |            | $nt_H+5.5$ |            | $nt_H+5.5$ |      |
|     |  |            | $nt_H+5.5$ |            | $nt_H+5$   |            | $nt_H+5$   |      |

† Tested across full voltage. Test temperature is selected by manufacturing test flow. Compliance across full temperature range is ensured by device characterization.

‡ Except for CAS/DQM[7:0] during non user-timed 2 cycle/column accesses

# TMS320C80 DIGITAL SIGNAL PROCESSOR

SPRS023B – JULY 1994 – REVISED OCTOBER 1997

## general output signal characteristics over full range of operating conditions† (continued)

| NO. | PARAMETER  | 'C80-40    |     | 'C80-50    |     | 'C80-60    |     | UNIT |
|-----|--|------------|-----|------------|-----|------------|-----|------|
|     |  | MIN        | MAX | MIN        | MAX | MIN        | MAX |      |
| 33  | $t_w(\text{OUTV})$<br>Pulse duration, output valid<br>D[63:0]<br>A[31:0], STATUS[5:0],<br>CAS/DQM[7:0]‡<br>DBEN, DDIN, DSF, RAS, RL,<br>TRG/CAS, W | $nt_H-7$   |     | $nt_H-6.5$ |     | $nt_H-6.1$ |     | ns   |
|     |  | $nt_H-6.5$ |     | $nt_H-5.5$ |     | $nt_H-5.5$ |     |      |
|     |  | $nt_H-5.5$ |     | $nt_H-5$   |     | $nt_H-5$   |     |      |

† Tested across full voltage. Test temperature is selected by manufacturing test flow. Compliance across full temperature range is ensured by device characterization.

‡ Except for CAS/DQM[7:0] during non user-timed 2 cycle/column accesses

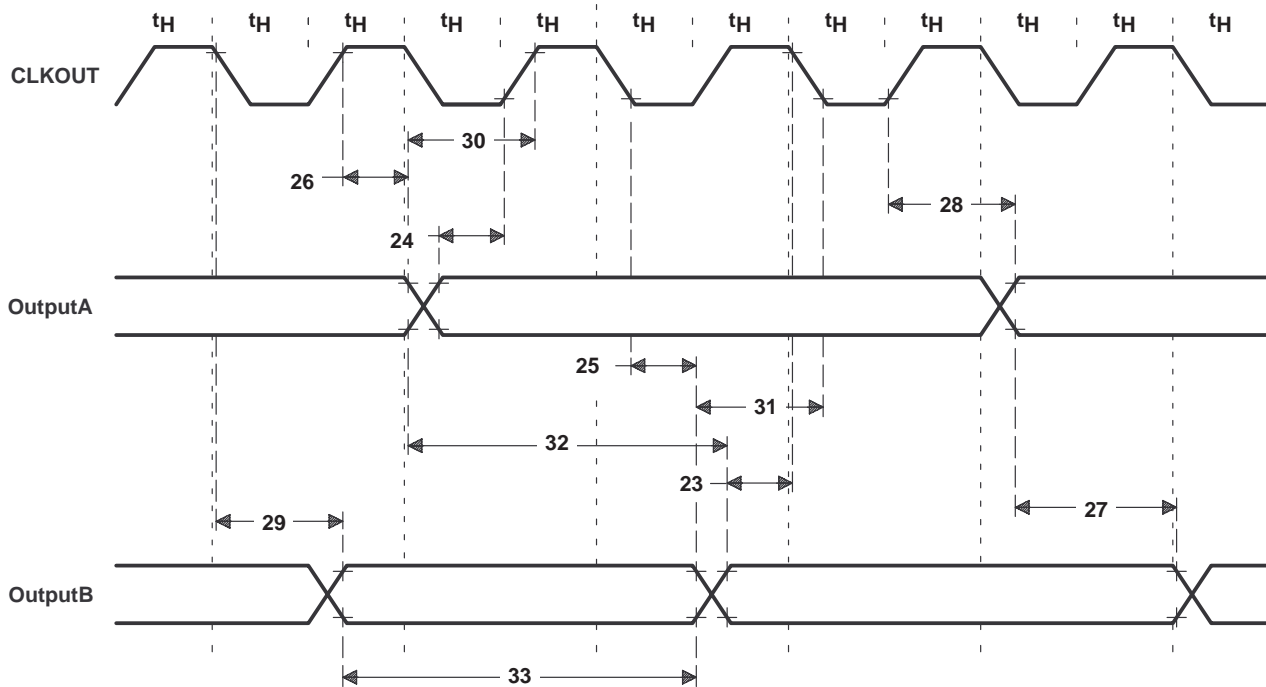

Figure 124. General Output-Signal Timing

**data input timing**

The following general timing parameters apply to the D[63:0] inputs unless otherwise specifically given. The value *n* as used in the parameters represents the integral number of half cycles between the transitions of the output and input in question (see Figure 125).

| NO. | PARAMETER   | 'C80-40 |          | 'C80-50 |            | 'C80-60 |            | UNIT |
|-----|---|---------|----------|---------|------------|---------|------------|------|
|     |   | MIN     | MAX      | MIN     | MAX        | MIN     | MAX        |      |
| 34  | $t_{a(CKOH-DV)}$ Access time, CLKOUT high to D[63:0] valid  |         | $nt_H-8$ |         | $nt_H-5.3$ |         | $nt_H-4.0$ | ns   |
| 35  | $t_{a(CKOL-DV)}$ Access time, CLKOUT low to D[63:0] valid   |         | $nt_H-8$ |         | $nt_H-6.5$ |         | $nt_H-6.5$ | ns   |
| 36  | $t_{su(DV-CKOH)}$ Setup time, D[63:0] valid to CLKOUT no longer low   | 8       |          | 6.1     |            | 6.1     |            | ns   |
| 37  | $t_{su(DV-CKOL)}$ Setup time, D[63:0] valid to CLKOUT no longer high  | 8       |          | 6.1     |            | 6.1     |            | ns   |
| 38  | $t_h(CKOL-DV)$ Hold time, D[63:0] valid after CLKOUT low  | 2       |          | 2       |            | 2       |            | ns   |
| 39  | $t_h(CKOH-DV)$ Hold time, D[63:0] valid after CLKOUT high   | 2       |          | 2       |            | 2       |            | ns   |
| 40  | $t_{a(OUTV-DV)}$ Access time, output valid to D[63:0] inputs valid<br>A[31:0], $\overline{CAS}/DQM[7:0]^\dagger$ , STATUS[5:0]<br>DBEN, DDIN, DSF, RAS, RL,<br>TRG/CAS, W |         | $nt_H-9$ |         | $nt_H-7$   |         | $nt_H-7$   | ns   |
|     |   |         | $nt_H-8$ |         | $nt_H-6.5$ |         | $nt_H-6.5$ |      |
| 41  | $t_h(OUTV-DV)^\ddagger$ Hold time, D[63:0] valid after output valid<br>RAS, $\overline{CAS}/DQM[7:0]$<br>A[31:0]  | 2<br>3  |          | 2<br>3  |            | 2<br>3  |            | ns   |

<sup>†</sup> Except  $\overline{CAS}/DQM[7:0]$  during non user-timed 2 cycle/column accesses

<sup>‡</sup> Applies to RAS,  $\overline{CAS}/DQM[7:0]$ , and A[31:0] transitions that occur on CLKOUT edge coincident with input data sampling

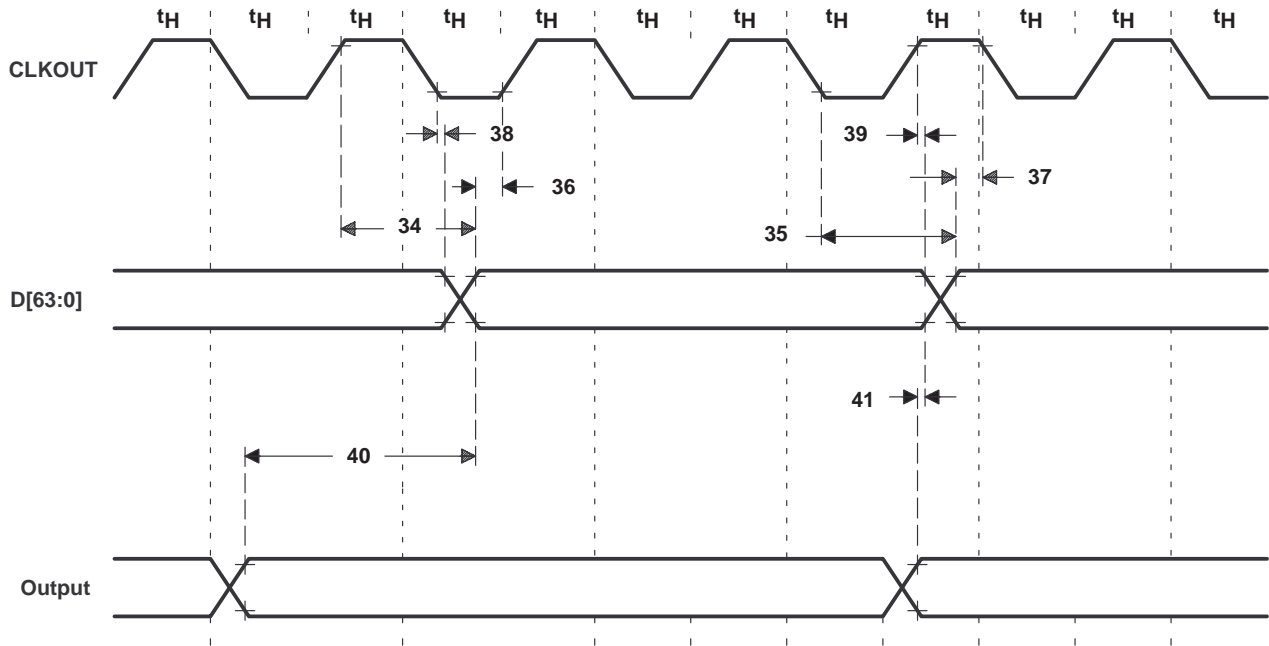

Figure 125. Data-Input Timing

# TMS320C80 DIGITAL SIGNAL PROCESSOR

SPRS023B – JULY 1994 – REVISED OCTOBER 1997

## local bus timing: 2 cycle/column $\overline{\text{CAS}}$ timing

These timing parameters apply to the  $\overline{\text{CAS}}/\text{DQM}[7:0]$  signals during 2 cycle per column memory accesses only. They should be used in place of the general output and data input timing parameters when the 2 cycle/column (non user-timed) cycle timing is selected (CT[2:0] inputs = 0b110). The value  $n$  as used in the parameters represents the integral number of half cycles between the transitions of the signals in question (see Figure 126).

| NO. |   | 'C80-40                              |           | 'C80-50<br>'C80-60                   |           | UNIT |
|-----|---|--------------------------------------|-----------|--------------------------------------|-----------|------|
|     |   | MIN                                  | MAX       | MIN                                  | MAX       |      |
| 42  | $t_w(\text{CASH})$ Pulse duration, $\overline{\text{CAS}}/\text{DQM}$ high  | $t_H-2$                              |           | $t_H-2$                              |           | ns   |
| 43  | $t_w(\text{CASL})$ Pulse duration, $\overline{\text{CAS}}/\text{DQM}$ low   | $3t_H-11$                            |           | $3t_H-9.5$                           |           | ns   |
| 44  | $t_h(\text{OUTV-CASL})$ Hold time, $\overline{\text{CAS}}/\text{DQM}$ high after output valid<br>D[63:0]<br>A[31:0], STATUS[5:0]<br>$\overline{\text{DBEN}}$ , $\overline{\text{DDIN}}$ , $\overline{\text{DSF}}$ , $\overline{\text{RAS}}$ , $\overline{\text{RL}}$ , $\overline{\text{TRG}}/\text{CAS}$ , $\overline{\text{W}}$ | $nt_H-5$<br>$nt_H-4.5$<br>$nt_H-3.5$ |           | $nt_H-4.5$<br>$nt_H-3.5$<br>$nt_H-3$ |           | ns   |
| 45  | $t_h(\text{CASL-OUTV})$ Hold time, output valid after $\overline{\text{CAS}}/\text{DQM}$ low  | $nt_H-11$                            |           | $nt_H-9.5$                           |           | ns   |
| 46  | $t_a(\text{CASL-DV})$ Access time, data valid from $\overline{\text{CAS}}/\text{DQM}$ low   |                                      | $3t_H-12$ |                                      | $3t_H-12$ | ns   |
| 47  | $t_h(\text{CASH-DV})$ Hold time, data valid after $\overline{\text{CAS}}/\text{DQM}$ high   | 2                                    |           | 2                                    |           | ns   |

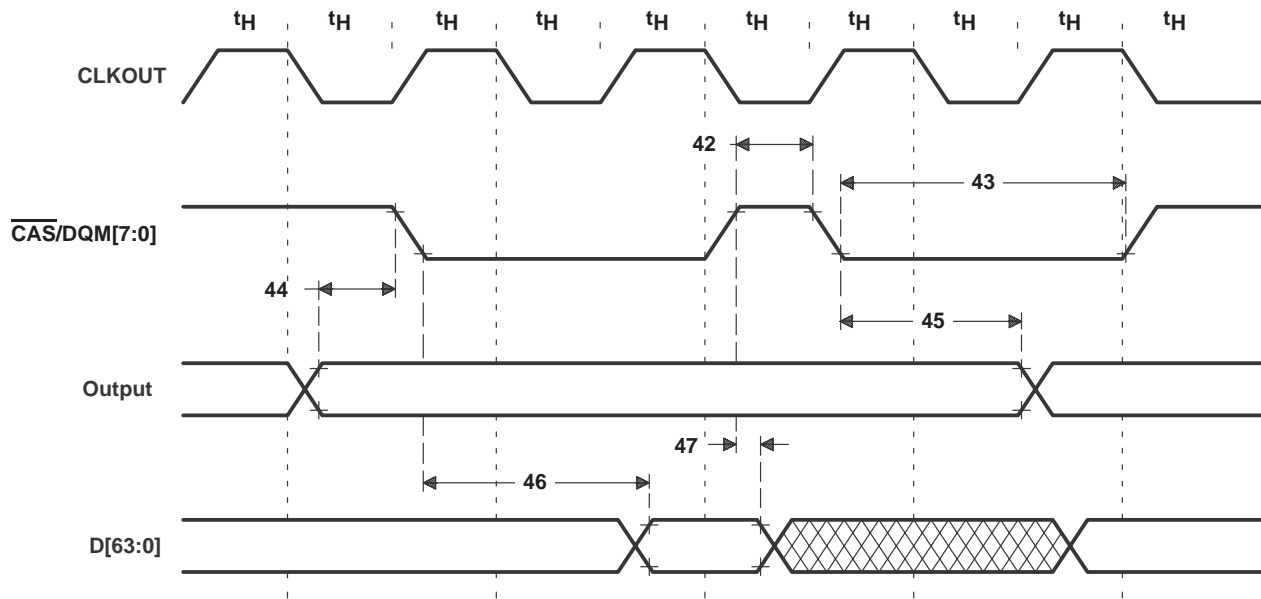

Figure 126. 2 Cycle/Column  $\overline{\text{CAS}}$  Timing

**external-interrupt timing**

The following description defines the timing of the edge-triggered interrupts  $\overline{EINT1}$  –  $\overline{EINT3}$  and the level triggered interrupt  $\overline{LINT4}$  (see Note 4). See Figure 127.

| NO. |  | 'C80-40 |     | 'C80-50<br>'C80-60 |     | UNIT |
|-----|--|---------|-----|--------------------|-----|------|
|     |  | MIN     | MAX | MIN                | MAX |      |
| 48  | $t_{w(EINL)}$ Pulse duration, $\overline{EINTx}$ low <sup>†</sup>                                | 6       |     | 6                  |     | ns   |
| 49  | $t_{su(EINH-CKOH)}$ Setup time, $\overline{EINTx}$ high before CLKOUT no longer low <sup>‡</sup> | 11.5    |     | 9.5                |     | ns   |
| 50  | $t_{w(EINH)}$ Pulse duration, $\overline{EINTx}$ high <sup>†</sup>                               | 6       |     | 6                  |     | ns   |
| 51  | $t_{su(LINL-CKOL)}$ Setup time, $\overline{LINT4}$ low before CLKOUT no longer high <sup>‡</sup> | 10      |     | 8                  |     | ns   |

<sup>†</sup> This parameter is assured by characterization and is not tested.

<sup>‡</sup> This parameter must only be met to ensure that the interrupt is recognized on the indicated cycle.

NOTE 4: In order to assure recognition,  $\overline{LINT4}$  must remain low until cleared by the interrupt service routine.

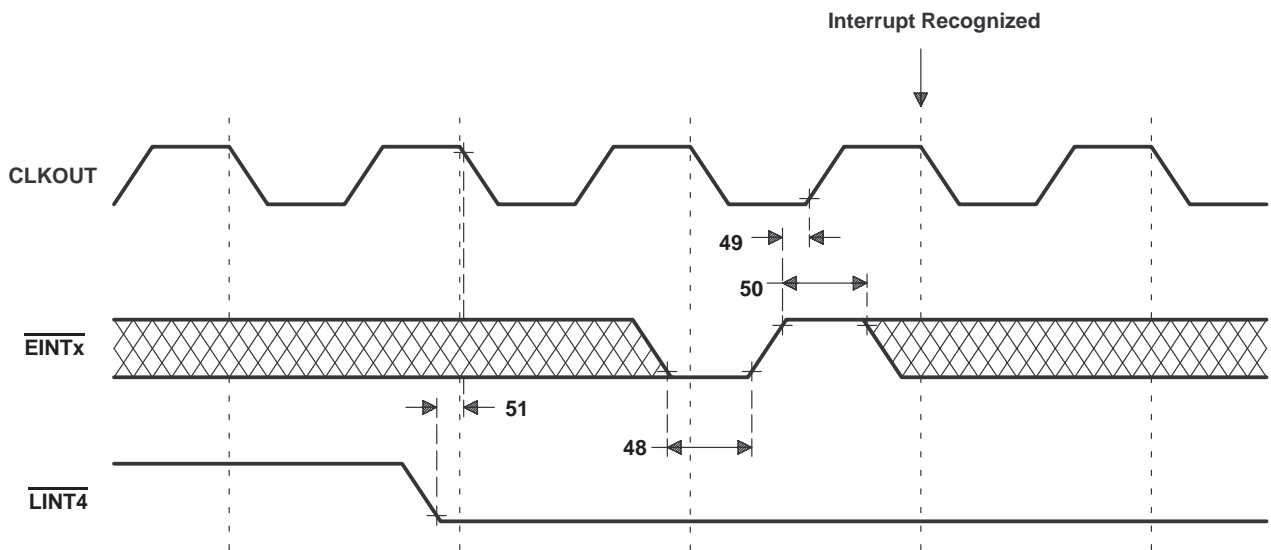

**Figure 127. External-Interrupt Timing**

**XPT input timing**

The following description defines the sampling of the  $\overline{\text{XPT}}[2:0]$  inputs. The value encoded on the  $\overline{\text{XPT}}[2:0]$  inputs is synchronized over multiple cycles to ensure that a stable value is present (see Figure 128 and Figure 129).

| NO. |  | 'C80-40          |                 | 'C80-50<br>'C80-60 |                 | UNIT |
|-----|--|------------------|-----------------|--------------------|-----------------|------|
|     |  | MIN              | MAX             | MIN                | MAX             |      |
| 52  | $t_w(\text{XPTV})$ Pulse duration, $\overline{\text{XPT}}_x$ valid†                                    | 12t <sub>H</sub> |                 | 12t <sub>H</sub>   |                 | ns   |
| 53  | $t_{su}(\text{XPTV-CKOH})$ Setup time, $\overline{\text{XPT}}[2:0]$ valid before CLKOUT no longer low‡ | 13.5             |                 | 12                 |                 | ns   |
| 54  | $t_h(\text{CKOH-XPTV})$ Hold time, $\overline{\text{XPT}}[2:0]$ valid after CLKOUT high                | 5                |                 | 5                  |                 | ns   |
| 55  | $t_h(\text{RLL-XPTV})$ Hold time, $\overline{\text{XPT}}[2:0]$ valid after $\overline{\text{RL}}$ low§ |                  | 6t <sub>H</sub> |                    | 6t <sub>H</sub> | ns   |

† This parameter is a functional minimum assured by logic and is not tested.

‡ This parameter must only be met to ensure that the XPT input is recognized on the indicated cycle.

§ This parameter must be met to ensure that a second XPT request does not occur. This parameter is a functional maximum assured by logic and is not tested.

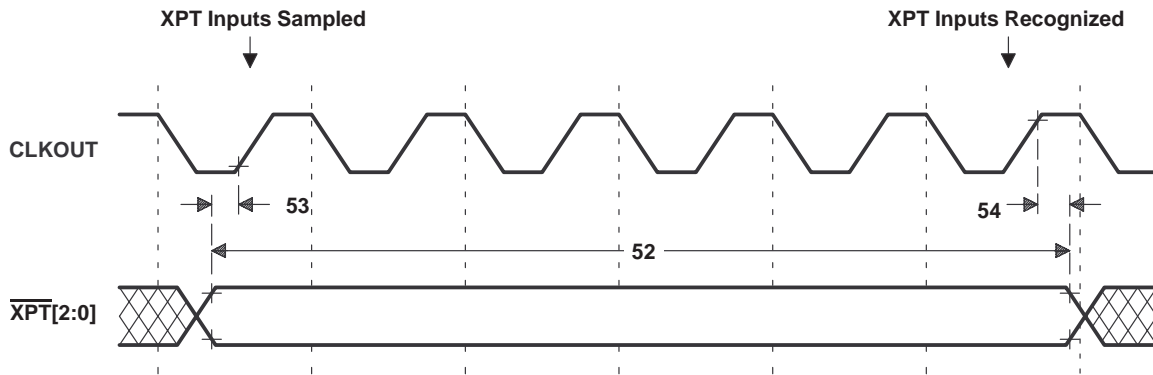

Figure 128. XPT Input Timing – XPT Recognition

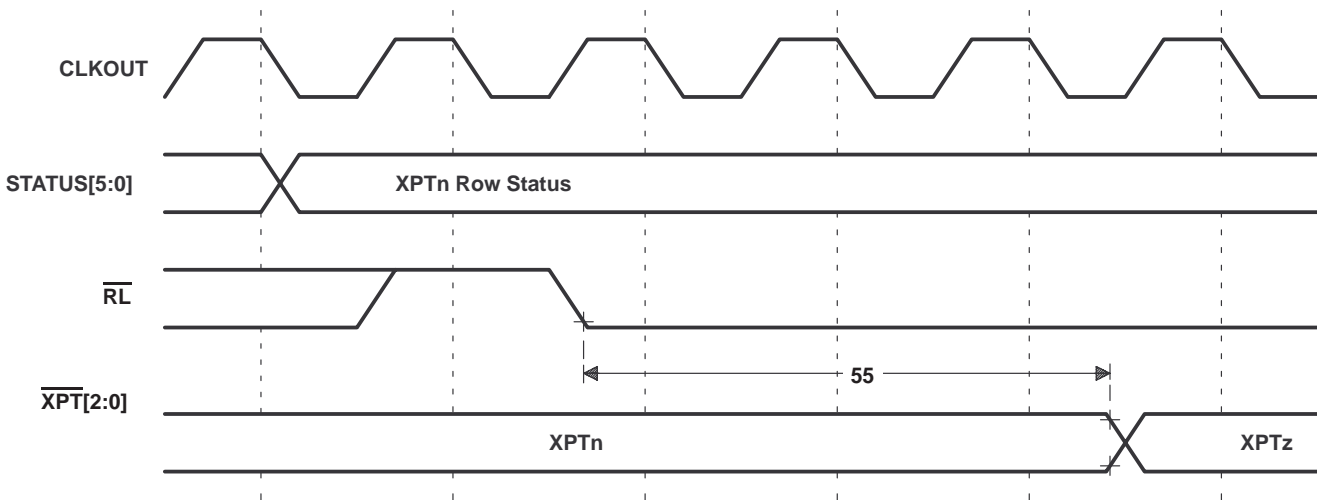

Figure 129. XPT Input Timing – XPT Service

**host-interface timing (see Figure 130)**

| NO. |  | 'C80-40                    |     | 'C80-50     |     | 'C80-60     |     | UNIT |
|-----|--|----------------------------|-----|-------------|-----|-------------|-----|------|
|     |  | MIN                        | MAX | MIN         | MAX | MIN         | MAX |      |
| 56  | $t_{su}(REQV-CKOH)$ Setup time, REQ1–REQ0 valid to CLKOUT no longer low                    | $t_H - 7$                  |     | $t_H - 7$   |     | $t_H - 5.5$ |     | ns   |
| 57  | $t_h(CKOH-REQV)$ Hold time, REQ1–REQ0 valid after CLKOUT high                              | $t_H - 7$                  |     | $t_H - 7$   |     | $t_H - 5.5$ |     | ns   |
| 58  | $t_h(HRQL-HAKL)$ Hold time for $\overline{HACK}$ high after $\overline{HREQ}$ goes low†    | $4t_H - 12$                |     | $4t_H - 12$ |     | $4t_H - 12$ |     | ns   |
| 59  | $t_d(HAKL-OUTZ)$ Delay time, $\overline{HACK}$ low to output hi-Z‡                         | All signals except D[63:0] |     | 0           | 0   | 0           | 0   | ns   |
|     |  | D[63:0]                    |     | 1           | 1   | 1           | 1   |      |
| 60  | $t_d(HRQH-HAKH)$ Delay time, $\overline{HREQ}$ high to $\overline{HACK}$ no longer low     | 10                         |     | 10          |     | 10          |     | ns   |
| 61  | $t_d(HAKH-OUTD)$ Delay time, $\overline{HACK}$ high to outputs driven†                     | $6t_H$                     |     | $6t_H$      |     | $6t_H$      |     |      |
| 62  | $t_{su}(HRQL-CKOH)$ Setup time, $\overline{HREQ}$ low to CLKOUT no longer low (see Note 5) | 10.5                       |     | 8.5         |     | 8.5         |     | ns   |

† This parameter is a functional minimum assured by logic and is not tested.

‡ This parameter is assured by characterization and is not tested.

NOTE 5: Parameter must be met only to ensure  $\overline{HREQ}$  recognition during the indicated clock cycle.

host-interface timing (see Figure 130) (continued)

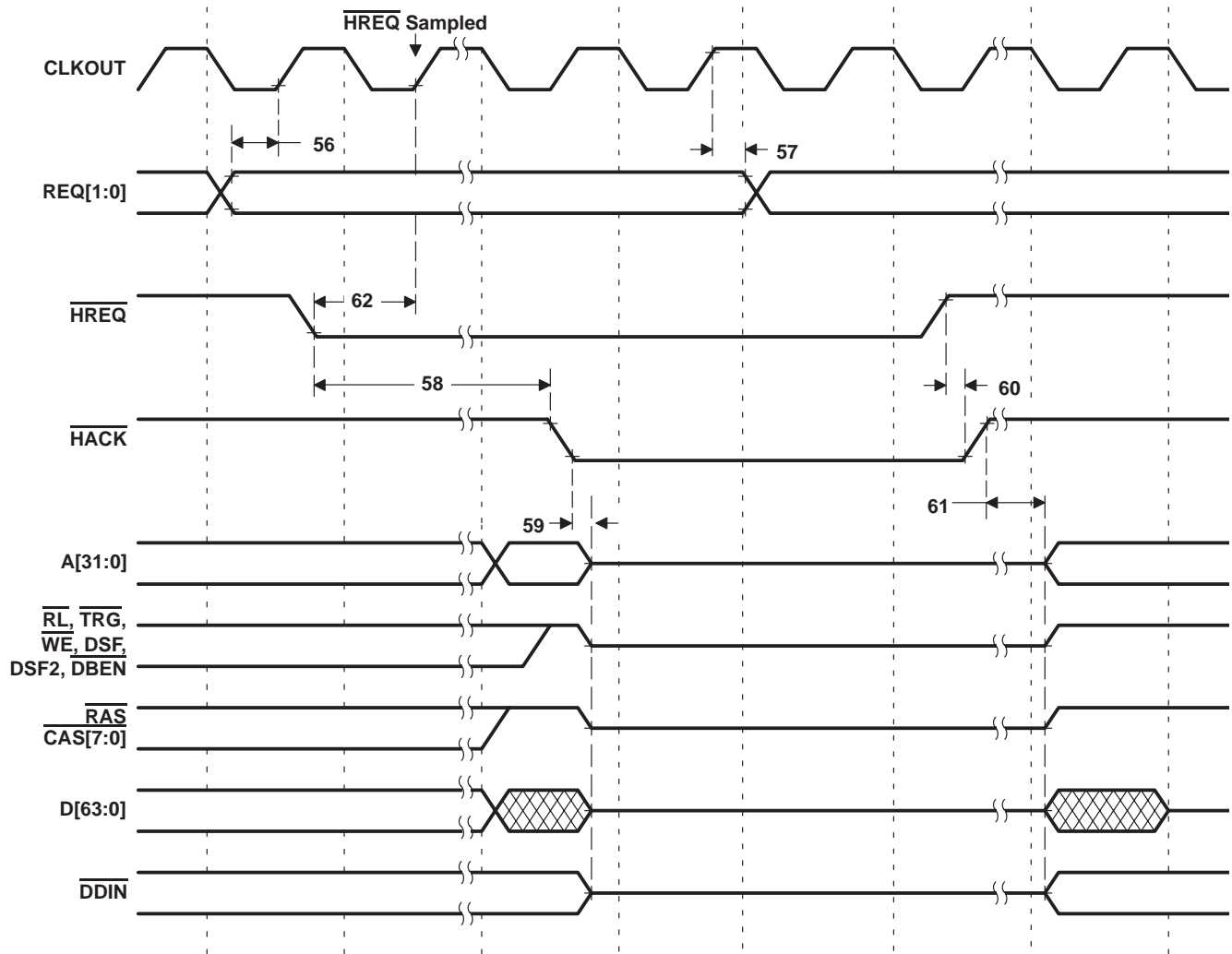

Figure 130. Host-Interface Timing

video interface timing: SCLK timing (see Figure 131)

| NO. |  | MIN | MAX | UNIT |
|-----|--|-----|-----|------|
| 63  | $t_c(\text{SCK})$ SCLK period  | 13  |     | ns   |
| 64  | $t_w(\text{SCKH})$ Pulse duration, SCLK high                         | 5   |     | ns   |
| 65  | $t_w(\text{SCKL})$ Pulse duration, SCLK low                          | 5   |     | ns   |
| 66  | $t_t(\text{SCK})$ Transition time, SCLK (rise and fall) <sup>†</sup> |     | 2   | ns   |

<sup>†</sup> This parameter is assured by simulation and is not tested.

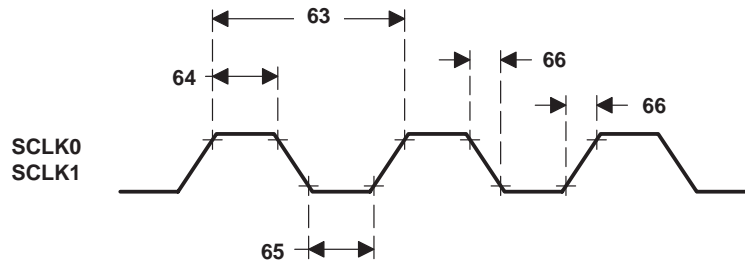

Figure 131. Video Interface Timing: SCLK Timing

# TMS320C80 DIGITAL SIGNAL PROCESSOR

SPRS023B – JULY 1994 – REVISED OCTOBER 1997

## video interface timing: FCLK input and video outputs (see Note 6 and Figure 132)

| NO. |   | MIN | MAX | UNIT |
|-----|---|-----|-----|------|
| 67  | $t_c(\text{FCK})$ FCLK period   | 25  |     | ns   |
| 68  | $t_w(\text{FCKH})$ Pulse duration, FCLK high  | 8   |     | ns   |
| 69  | $t_w(\text{FCKL})$ Pulse duration, FCLK low   | 8   |     | ns   |
| 70  | $t_t(\text{FCK})$ Transition time, FCLK (rise and fall) <sup>†</sup>  |     | 2   | ns   |
| 71  | $t_h(\text{FCKL-SYL})$ Hold time, $\overline{\text{HSYNC}}$ , $\overline{\text{VSYNC}}$ , $\overline{\text{CSYNC}}/\overline{\text{HBLNK}}$ , $\overline{\text{CBLNK}}/\overline{\text{VBLNK}}$ , or CAREA high after FCLK low          | 0   |     | ns   |
| 72  | $t_h(\text{FCKL-SYH})$ Hold time, $\overline{\text{HSYNC}}$ , $\overline{\text{VSYNC}}$ , $\overline{\text{CSYNC}}/\overline{\text{HBLNK}}$ , $\overline{\text{CBLNK}}/\overline{\text{VBLNK}}$ , or CAREA low after FCLK low           | 0   |     | ns   |
| 73  | $t_d(\text{FCKL-SYL})$ Delay time, FCLK no longer high to $\overline{\text{HSYNC}}$ , $\overline{\text{VSYNC}}$ , $\overline{\text{CSYNC}}/\overline{\text{HBLNK}}$ , $\overline{\text{CBLNK}}/\overline{\text{VBLNK}}$ , or CAREA low  |     | 20  | ns   |
| 74  | $t_d(\text{FCKL-SYH})$ Delay time, FCLK no longer high to $\overline{\text{HSYNC}}$ , $\overline{\text{VSYNC}}$ , $\overline{\text{CSYNC}}/\overline{\text{HBLNK}}$ , $\overline{\text{CBLNK}}/\overline{\text{VBLNK}}$ , or CAREA high |     | 20  | ns   |

<sup>†</sup> This parameter is assured by simulation and is not tested.

NOTE 6: Under certain circumstances these outputs also can transition asynchronously. These transitions occur when controller timing register values are modified by user programming. If the new register value forces the output to change states then this transition occurs without regard to FCLK inputs.

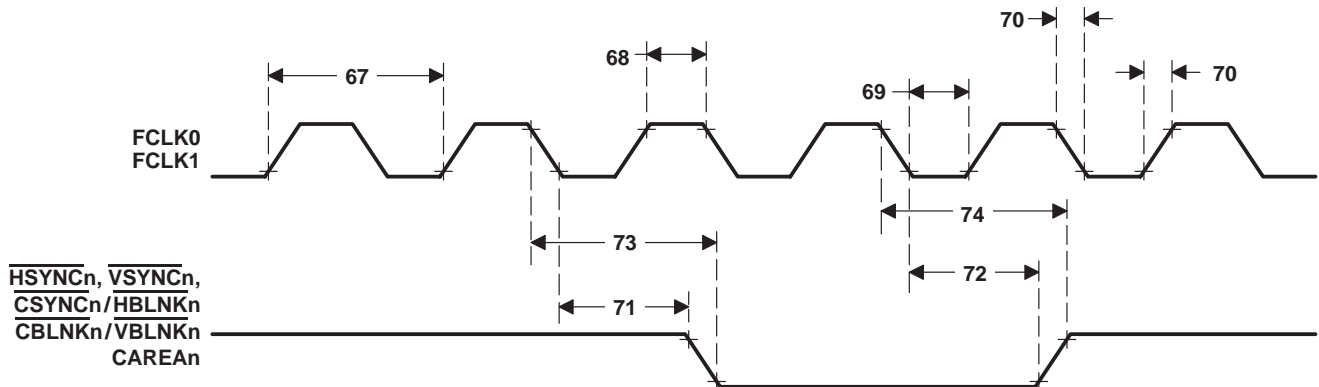

Figure 132. Video Interface Timing: FCLK Input and Video Outputs

**video interface timing: external sync inputs**

When configured as inputs, the  $\overline{\text{HSYNC}}_n$ ,  $\overline{\text{VSYNC}}_n$ , and  $\overline{\text{CSYNC}}_n$  signals may be driven asynchronously. The following parameters apply only when the inputs are being generated synchronous to FCLK $_n$  in order to ensure recognition on a particular FLCK $_n$  edge (see Figure 133).

| NO. |  | MIN | MAX | UNIT |
|-----|--|-----|-----|------|
| 75  | $t_{su}(\text{SIL-FCKH})$ Setup time, $\overline{\text{HSYNC}}$ , $\overline{\text{VSYNC}}$ , or $\overline{\text{CSYNC}}$ low to FCLK no longer low <sup>†</sup>  | 5   |     | ns   |
| 76  | $t_h(\text{FCKH-SIL})$ Hold time, $\overline{\text{HSYNC}}$ , $\overline{\text{VSYNC}}$ , or $\overline{\text{CSYNC}}$ high after FCLK high <sup>‡</sup>           | 7   |     | ns   |
| 77  | $t_{su}(\text{SIH-FCKH})$ Setup time, $\overline{\text{HSYNC}}$ , $\overline{\text{VSYNC}}$ , or $\overline{\text{CSYNC}}$ high to FCLK no longer low <sup>§</sup> | 5   |     | ns   |
| 78  | $t_h(\text{FCKH-SIH})$ Hold time, $\overline{\text{HSYNC}}$ , $\overline{\text{VSYNC}}$ , or $\overline{\text{CSYNC}}$ low after FCLK high <sup>¶</sup>            | 7   |     | ns   |

<sup>†</sup> This parameter must be met only to ensure the input is recognized as low at FLCK edge B.

<sup>‡</sup> This parameter must be met only to ensure the input is recognized as high at FLCK edge A.

<sup>§</sup> This parameter must be met only to ensure the input is recognized as high at FLCK edge D.

<sup>¶</sup> This parameter must be met only to ensure the input is recognized as low at FLCK edge C.

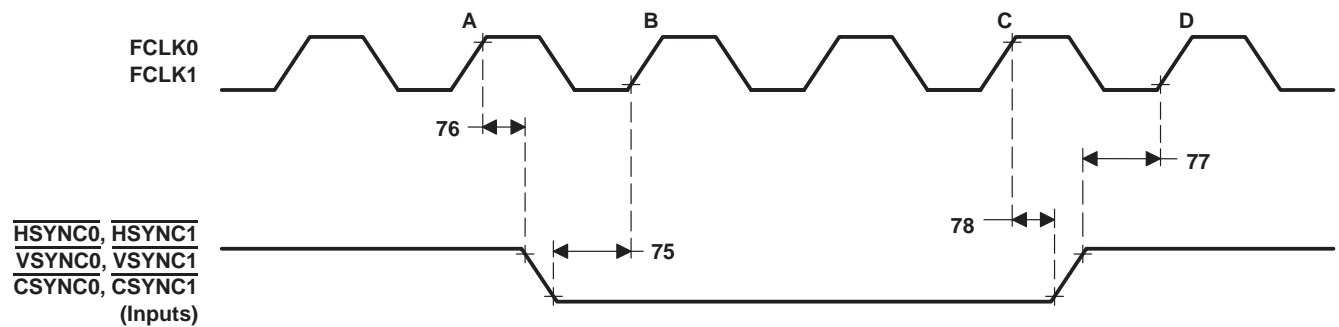

**Figure 133. Video Interface Timing: External Sync Inputs**

## thermal resistance

Figure 134 illustrates the maximum ambient temperature allowed for various air flow rates across the TMS320C80 to ensure that the case temperature is kept below the maximum operating temperature (85°C) (see Note A). Values for the GF package include integral heat sink. Values for the GGP package are with no heat sink.

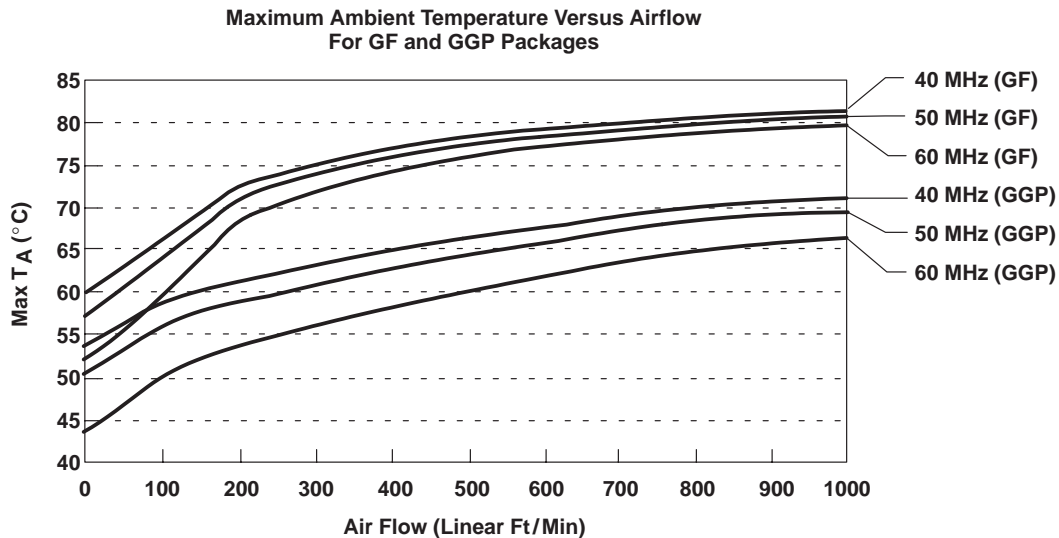

NOTE A: TMS320C80 power consumption is based on the “typical” values of  $I_{DD}$  measured at  $V_{DD} = 3.3$  V. Power consumption varies by application based on TMS320C80 processor activity and I/O pin loadings. User must ensure that the case temperature ( $T_C$ ) specifications are met when defining airflow and other thermal constraints of their system.

**Figure 134. Airflow Requirements**

### emulator interface connection

The 'C80 supports emulation through a dedicated emulation port that is a superset of the IEEE Standard 1149.1 (JTAG) Standard. To support the 'C80 emulator, a target system must include a 14-pin header (2 rows of 7 pins) with the connections shown in Figure 135.

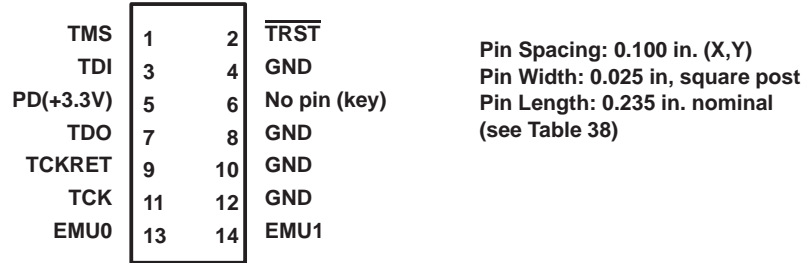

Figure 135. Target System Header

Table 38. Target Connectors

| XDS 510 SIGNAL           | XDS 510 STATE | TARGET STATE | DESCRIPTION   |
|--------------------------|---------------|--------------|---|
| TMS                      | O             | I            | Test-mode select <sup>†</sup>   |
| TDI                      | O             | I            | Test-data input <sup>†</sup>  |
| TDO                      | I             | O            | Test-data output <sup>†</sup>   |
| TCK                      | O             | I            | Test clock – 10 MHz clock source from emulator. Can be used to drive system-test clock. <sup>†</sup>                    |
| $\overline{\text{TRST}}$ | O             | I            | Test reset <sup>†</sup>   |
| EMU0                     | I             | I/O          | Emulation pin 0   |
| EMU1                     | I             | I/O          | Emulation pin 1   |
| PD (3.3 V)               | I             | O            | Presence detect. Indicates that the target is connected and powered up. Should be tied to + 3.3 V on target system.     |
| TCKRET                   | I             | O            | Test clock return. Test clock input to the XDS 510 emulator. Can be buffered or unbuffered version of TCK. <sup>†</sup> |

<sup>†</sup> IEEE Standard 1149.1.

For best results, the emulation header should be located as close as possible to the 'C80. If the distance exceeds six inches, the emulation signals should be buffered. See Figure 136.

emulator-interface connection (continued)

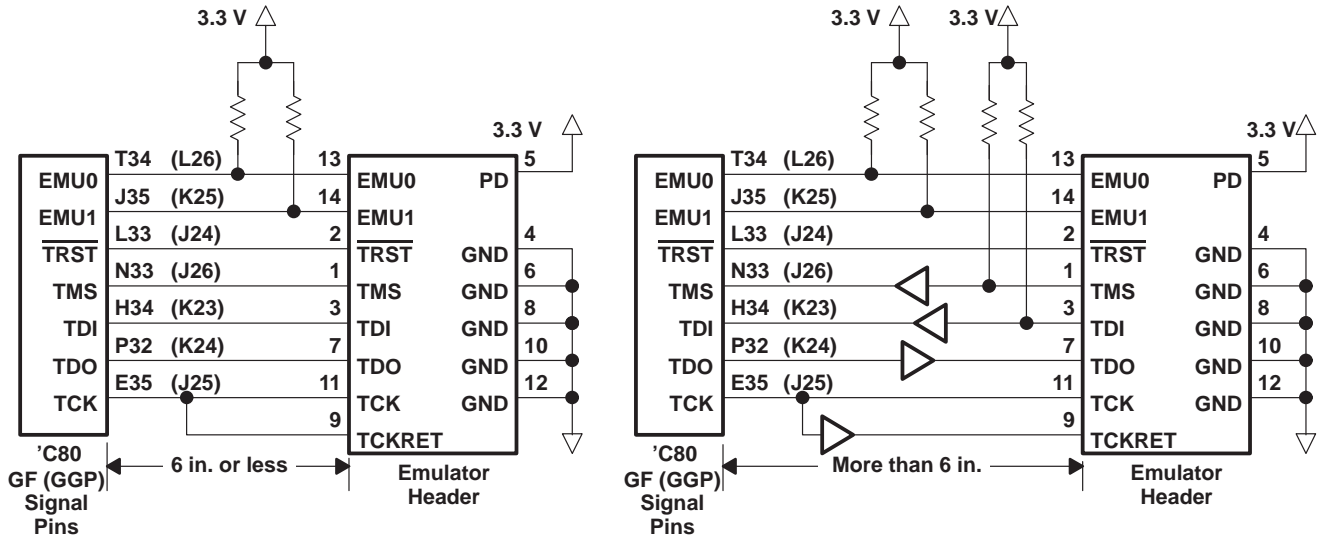

Figure 136. Emulation Header Connections – Emulator Driven Test Clock

The target system also can generate the test clock. This allows the user to:

- Set the test clock frequency to match the system requirements. (The emulator provides only a 10-MHz test clock.)
- Have other devices in the system that require a test clock when the emulator is not connected

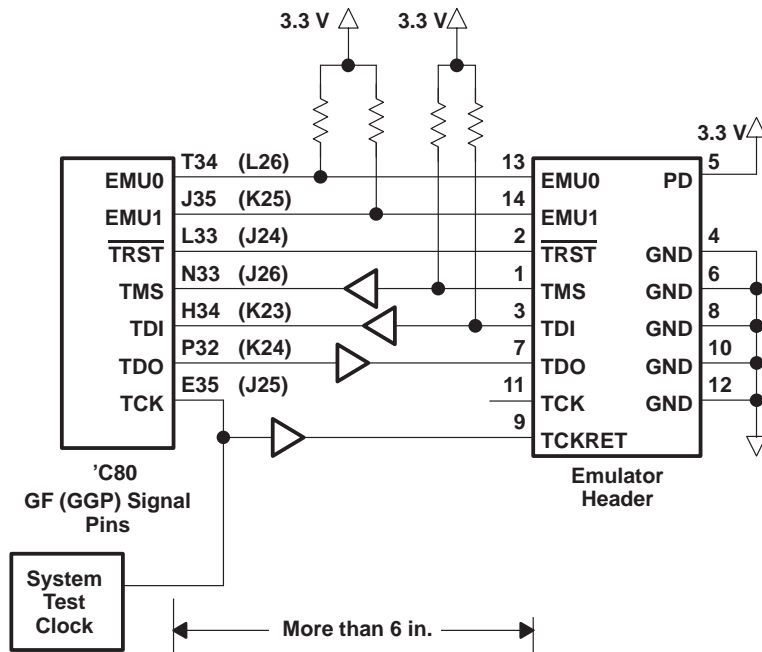
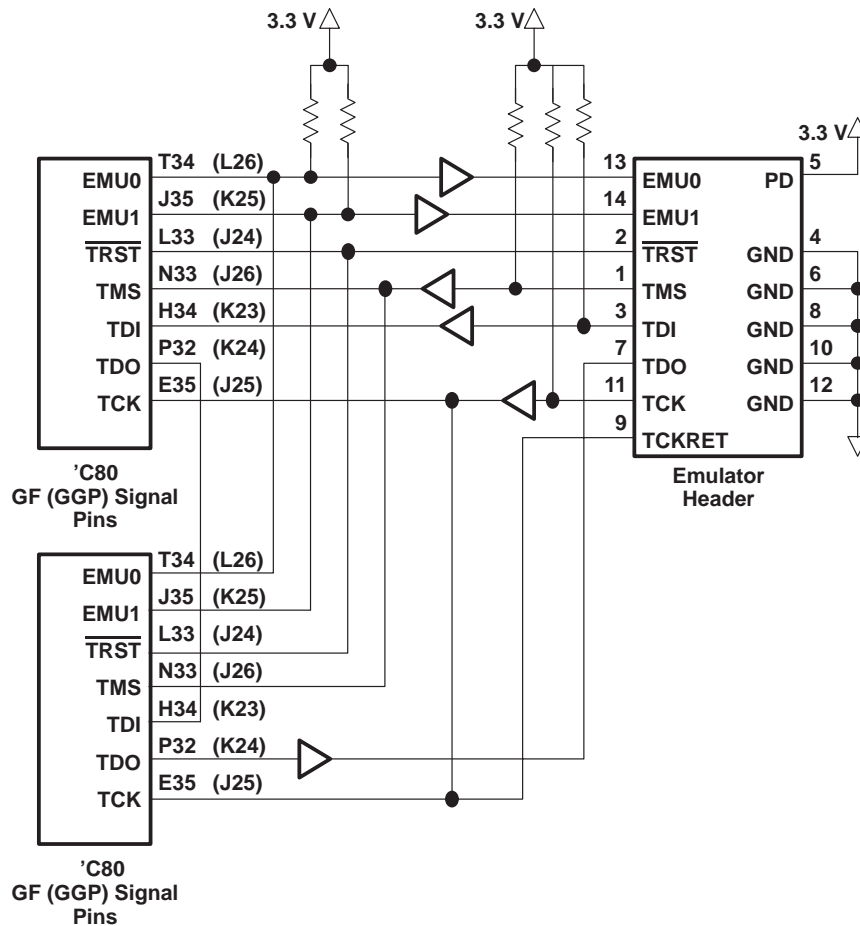

Figure 137. Emulation Header Connections – System Driven Test Clock

**emulator-interface connection (continued)**

For multiprocessor applications, the following conditions are recommended:

- To reduce timing skew, buffer TMS, TDI, TDO, and TCK through the same physical package.
- If buffering is used, 4.7 kΩ resistors are recommended for TMS, TDI, and TCK which should be pulled high (3.3 V).
- Buffering EMU0 and EMU1 is highly recommended to provide isolation. The buffers need not be in the same physical package as TMS, TCK, TDI, or TDO. Pullups to 3.3 V are required and should provide a signal rise time of less than 10 μs. A 4.7 kΩ resistor is suggested for most applications.
- To ensure high quality signals, special printed wire board (PWB) routing and use of termination resistors may be required. The emulator provides fixed series termination (33 Ω) on TMS and TDI and optional parallel terminators (180 Ω pullup and 270 Ω pulldown) on TCKRET and TDO.

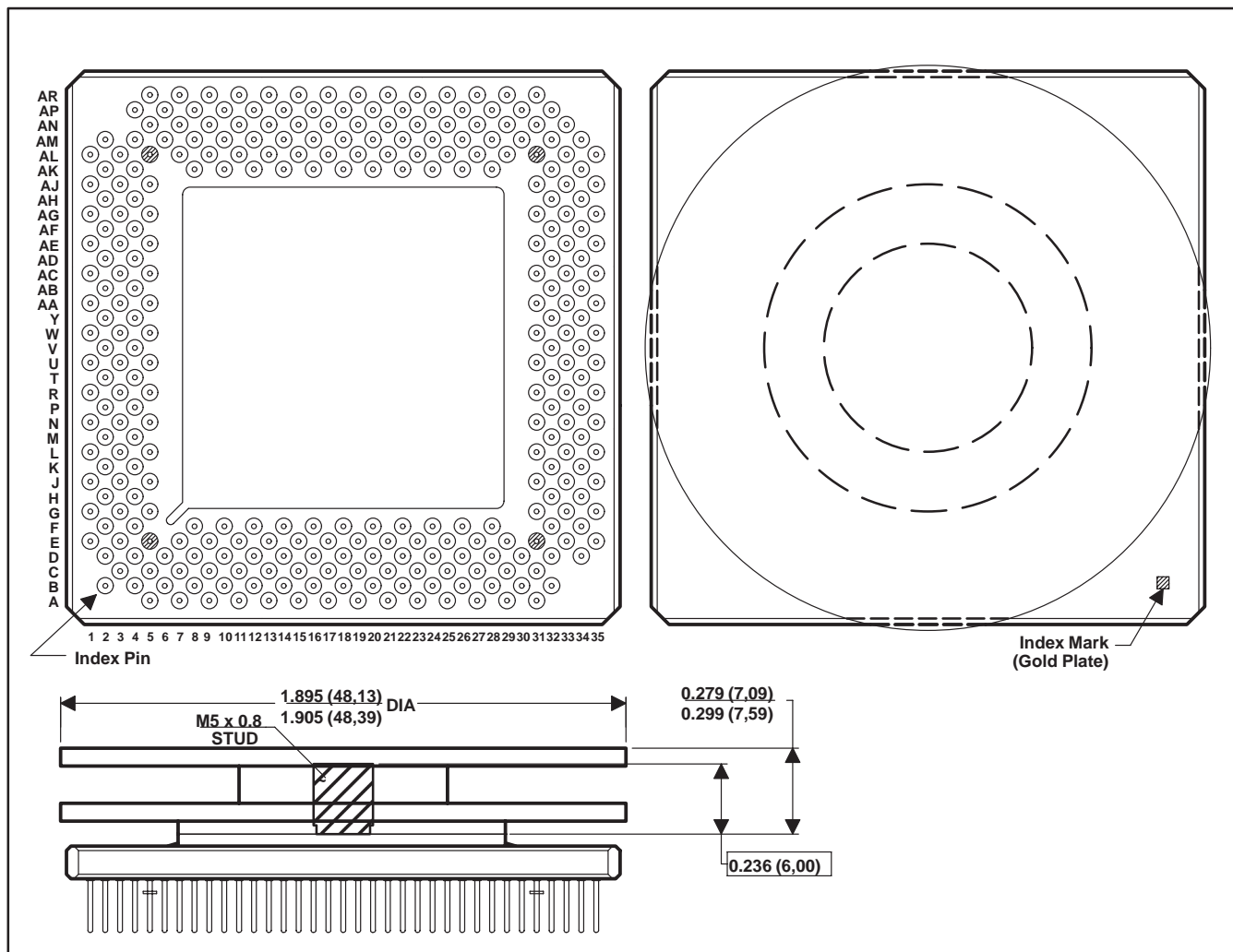

**Figure 138. Emulation Header Connections – Multiprocessor Applications**

# TMS320C80 DIGITAL SIGNAL PROCESSOR

SPRS023B – JULY 1994 – REVISED OCTOBER 1997

## GF package drawing



- NOTES: A. Pins are located within 0,13 (0.005) radius of the true position relative to each other at maximum material condition and within 0,457 (0.018) radius of the center of the ceramic.  
 B. Dimensions do not include solder finish.

**Figure 139. Assembled Package Drawing Showing Integral Heatsink**



# TMS320C80 DIGITAL SIGNAL PROCESSOR

SPRS023B – JULY 1994 – REVISED OCTOBER 1997

## MECHANICAL DATA

GGP (S-PBGA-N352)

PLASTIC BALL GRID ARRAY (CAVITY DOWN) PACKAGE

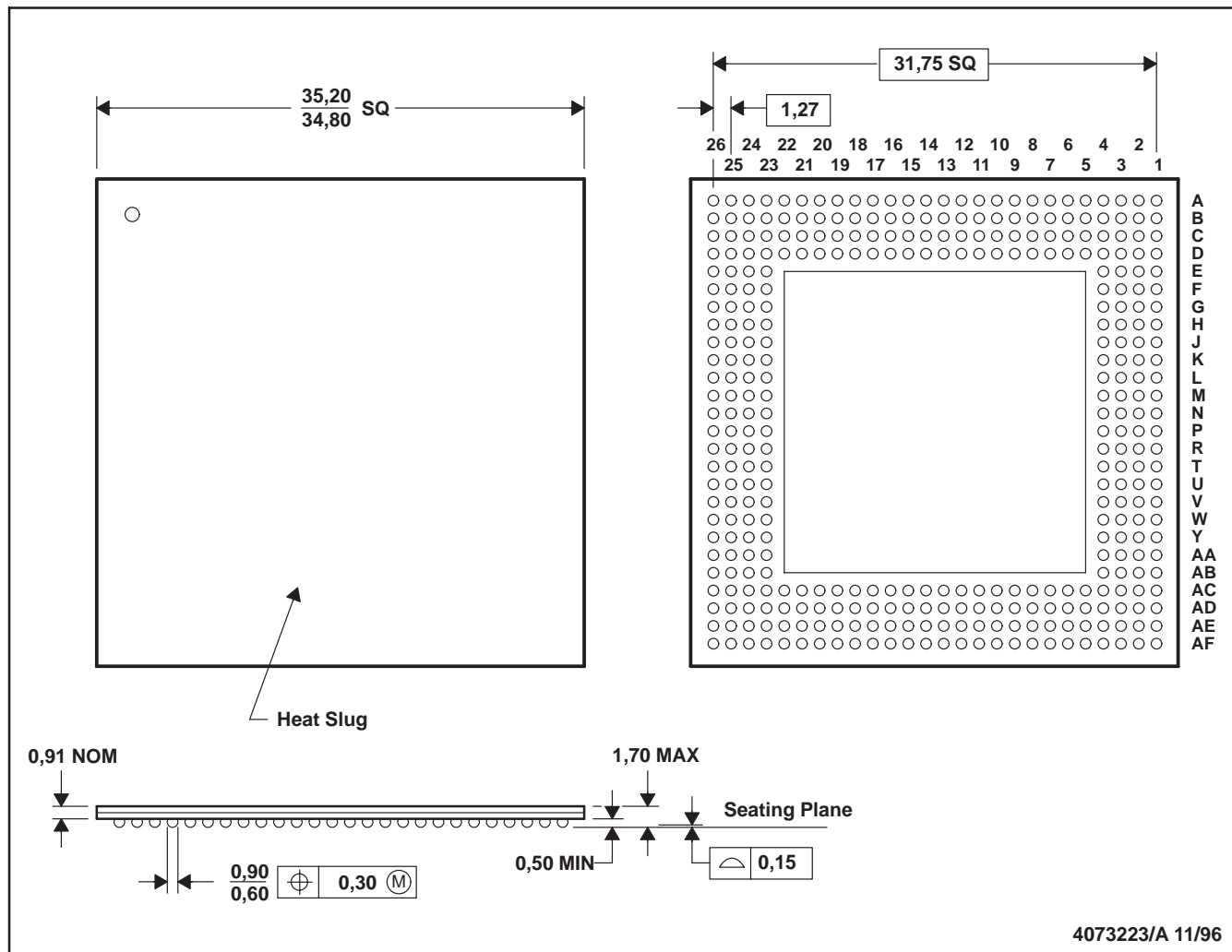

- NOTES: A. All linear dimensions are in millimeters.  
 B. This drawing is subject to change without notice.  
 C. Thermally enhanced die down plastic package with top surface metal heat slug.

## IMPORTANT NOTICE

Texas Instruments and its subsidiaries (TI) reserve the right to make changes to their products or to discontinue any product or service without notice, and advise customers to obtain the latest version of relevant information to verify, before placing orders, that information being relied on is current and complete. All products are sold subject to the terms and conditions of sale supplied at the time of order acknowledgement, including those pertaining to warranty, patent infringement, and limitation of liability.

TI warrants performance of its semiconductor products to the specifications applicable at the time of sale in accordance with TI's standard warranty. Testing and other quality control techniques are utilized to the extent TI deems necessary to support this warranty. Specific testing of all parameters of each device is not necessarily performed, except those mandated by government requirements.

CERTAIN APPLICATIONS USING SEMICONDUCTOR PRODUCTS MAY INVOLVE POTENTIAL RISKS OF DEATH, PERSONAL INJURY, OR SEVERE PROPERTY OR ENVIRONMENTAL DAMAGE ("CRITICAL APPLICATIONS"). TI SEMICONDUCTOR PRODUCTS ARE NOT DESIGNED, AUTHORIZED, OR WARRANTED TO BE SUITABLE FOR USE IN LIFE-SUPPORT DEVICES OR SYSTEMS OR OTHER CRITICAL APPLICATIONS. INCLUSION OF TI PRODUCTS IN SUCH APPLICATIONS IS UNDERSTOOD TO BE FULLY AT THE CUSTOMER'S RISK.

In order to minimize risks associated with the customer's applications, adequate design and operating safeguards must be provided by the customer to minimize inherent or procedural hazards.

TI assumes no liability for applications assistance or customer product design. TI does not warrant or represent that any license, either express or implied, is granted under any patent right, copyright, mask work right, or other intellectual property right of TI covering or relating to any combination, machine, or process in which such semiconductor products or services might be or are used. TI's publication of information regarding any third party's products or services does not constitute TI's approval, warranty or endorsement thereof.

## Looking for pricing, stock, or lifecycle information?

Click below to explore more details on WIN SOURCE:

 [View TMS320C80GGP60 on WIN SOURCE](#)

 [Texas Instruments](#) Information

## Optimize Your Supply Chain with WIN SOURCE Solutions

-  Global Sourcing Solution
-  Obsolete Management
-  Cost Control Management
-  Shortage Management
-  Alternative Solution
-  Excess Inventory Management