



**THE DATASHEET OF
SNJ5472J**



SN5472, SN7472

AND-GATED J-K MASTER-SLAVE FLIP-FLOPS WITH PRESET AND CLEAR

SDLS117 – DECEMBER 1983 – REVISED MARCH 1988

- Package Options Include Plastic and Ceramic DIPs and Ceramic Flat Packages
- Dependable Texas Instruments Quality and Reliability

description

These J-K flip-flops are based on the master-slave principle and each has AND gate inputs for entry into the master section which are controlled by the clock pulse. The clock pulse also regulates the state of the coupling transistors which connect the master and slave sections. The sequence of operation is as follows:

1. Isolate slave from master
2. Enter information from AND gate inputs to master
3. Disable AND gate inputs
4. Transfer information from master to slave

The logical states of the J and K inputs must not be allowed to change when the clock pulse is in a high state.

The SN5472, and the SN54H72 are characterized for operation over the full military temperature range of -55°C to 125°C . The SN7472 is characterized for operation from 0°C to 70°C .

FUNCTION TABLE

INPUTS					OUTPUTS	
$\overline{\text{PRE}}$	$\overline{\text{CLR}}$	CLK	J	K	Q	$\overline{\text{Q}}$
L	H	X	X	X	H	L
H	L	X	X	X	L	H
L	L	X	X	X	H^{\dagger}	H^{\dagger}
H	H	\square	L	L	Q_0	$\overline{\text{Q}}_0$
H	H	\square	H	L	H	L
H	H	\square	L	H	L	H
H	H	\square	H	H	TOGGLE	

\dagger This configuration is nonstable; that is, it will not persist when either preset or clear returns to its inactive (high) level.

SN5472 . . . J PACKAGE
SN7472 . . . N PACKAGE
(TOP VIEW)

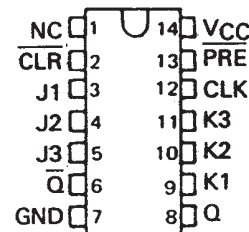

SN5472 . . . W PACKAGE
(TOP VIEW)

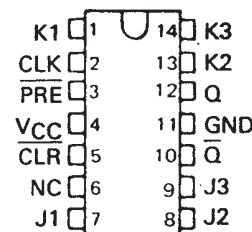

NC - No internal connection

logic symbol \ddagger

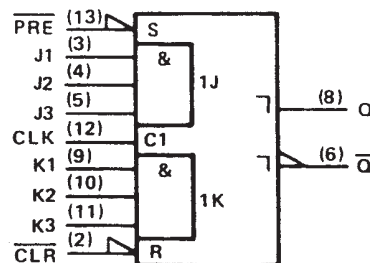

\ddagger This symbol is in accordance with ANSI/IEEE Std. 91-1984 and IEC Publication 617-12.

Pin numbers shown are for J and N packages.

positive logic

$$J = J1 \cdot J2 \cdot J3$$

$$K = K1 \cdot K2 \cdot K3$$

SN5472, SN7472 AND-GATED J-K MASTER-SLAVE FLIP-FLOPS WITH PRESET AND CLEAR

SDLS117 – DECEMBER 1983 – REVISED MARCH 1988

logic diagram (positive logic)

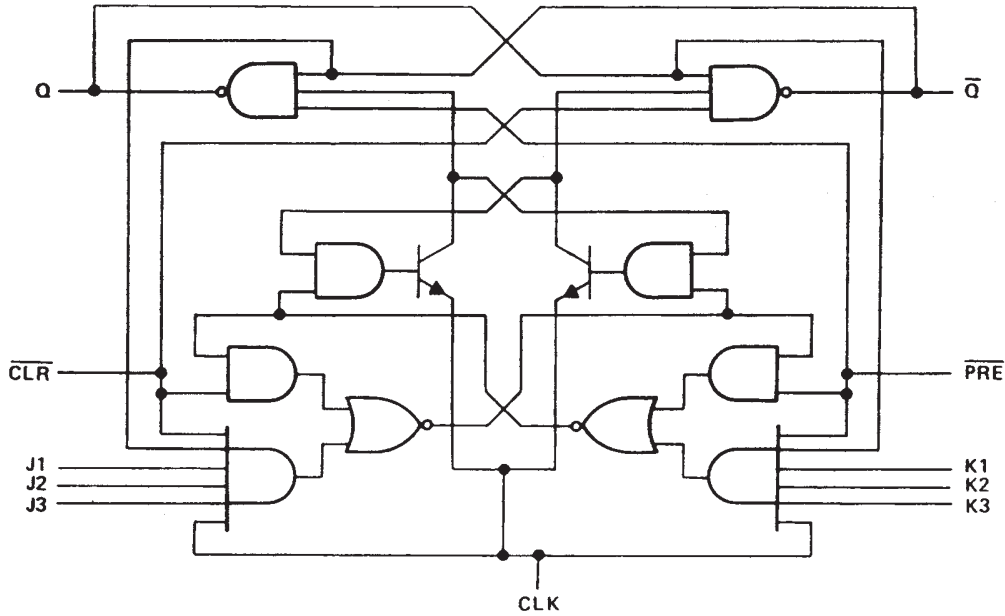

schematics of inputs and outputs

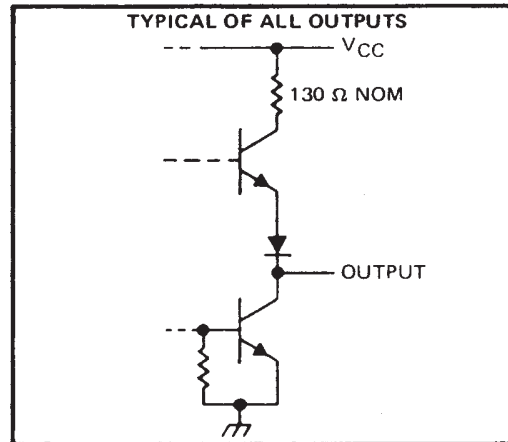
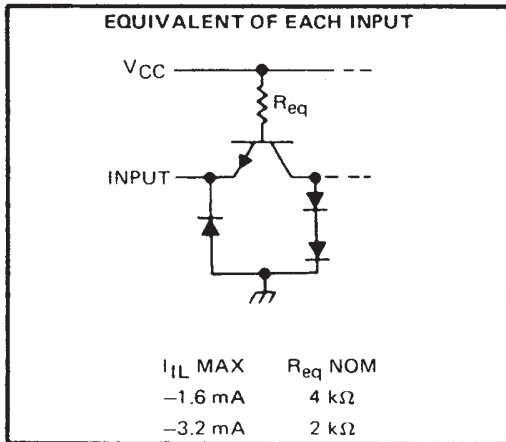

absolute maximum ratings over operating free-air temperature range (unless otherwise noted)

Supply voltage, V_{CC} (see Note 1)	7 V
Input voltage	5.5 V
Operating free-air temperature: SN54'	-55°C to 125°C
SN74'	0°C to 70°C
Storage temperature range	-65°C to 150°C

NOTE 1: Voltage values are with respect to network ground terminal.

SN5472, SN7472 AND-GATED J-K MASTER-SLAVE FLIP-FLOPS WITH PRESET AND CLEAR

SDLS117 – DECEMBER 1983 – REVISED MARCH 1988

recommended operating conditions

		SN5472			SN7472			UNIT	
		MIN	NOM	MAX	MIN	NOM	MAX		
V_{CC}	Supply voltage	4.5	5	5.5	4.75	5	5.25	V	
V_{IH}	High-level input voltage	2			2			V	
V_{IL}	Low-level input voltage	0.8			0.8			V	
I_{OH}	High-level output current	-0.4			-0.4			mA	
I_{OL}	Low-level output current	16			16			mA	
t_w	Pulse duration	CLK high	20		20		ns		
		CLK low	47		47				
		PRE or CLR	25		25				
t_{su}	Input setup time before CLK ↑	0			0			ns	
t_h	Input hold time-data after CLK ↓	0			0			ns	
T_A	Operating free-air temperature	-55		125		0		70	°C

electrical characteristics over recommended operating free-air temperature range (unless otherwise noted)

PARAMETER		TEST CONDITIONS †	SN5472			SN7472			UNIT	
			MIN	TYP‡	MAX	MIN	TYP‡	MAX		
V_{IK}		$V_{CC} = \text{MIN}, I_I = -12 \text{ mA}$	-1.5			-1.5			V	
V_{OH}		$V_{CC} = \text{MIN}, V_{IH} = 2 \text{ V}, V_{IL} = 0.8 \text{ V}, I_{OH} = -0.4 \text{ mA}$	2.4	3.4		2.4	3.4		V	
V_{OL}		$V_{CC} = \text{MIN}, V_{IH} = 2 \text{ V}, V_{IL} = 0.8 \text{ V}, I_{OL} = 16 \text{ mA}$		0.2	0.4		0.2	0.4	V	
I_I		$V_{CC} = \text{MAX}, V_I = 5.5 \text{ V}$	1			1			mA	
I_{IH}	J or K	$V_{CC} = \text{MAX}, V_I = 2.4 \text{ V}$	40			40			μA	
	All other		80			80				
I_{IL}	J or K	$V_{CC} = \text{MAX}, V_I = 0.4 \text{ V}$	-1.6			-1.6			mA	
	All other		-3.2			-3.2				
$I_{OS}\S$		$V_{CC} = \text{MAX}$	-20		-57	-18		-57	mA	
I_{CC}		$V_{CC} = \text{MAX},$ See Note 2	10		20		10		20	mA

† For conditions shown as MIN or MAX, use the appropriate value specified under recommended operating conditions.

‡ All typical values are at $V_{CC} = 5 \text{ V}, T_A = 25^\circ\text{C}$.

§ Not more than one output should be shorted at a time.

NOTE 2: With all outputs open, I_{CC} is measured with the Q and \bar{Q} outputs high in turn. At the time of measurement, the clock input is grounded.

switching characteristics, $V_{CC} = 5 \text{ V}, T_A = 25^\circ\text{C}$ (see note 3)

PARAMETER	FROM (INPUT)	TO (OUTPUT)	TEST CONDITIONS		MIN	TYP	MAX	UNIT	
f_{max}			$R_L = 400 \Omega, C_L = 15 \text{ pF}$		15	20		MHz	
t_{PLH}	$\overline{\text{PRE}}$ or $\overline{\text{CLR}}$	Q or \bar{Q}				16	25		ns
t_{PHL}						25	40		ns
t_{PLH}	CLK	Q or \bar{Q}				16	25		ns
t_{PHL}						25	40		ns

NOTE 3: Load circuits and voltage waveforms are shown in Section 1.



PACKAGING INFORMATION

Orderable Device	Status (1)	Package Type	Package Drawing	Pins	Package Qty	Eco Plan (2)	Lead finish/ Ball material (6)	MSL Peak Temp (3)	Op Temp (°C)	Device Marking (4/5)	Samples
SN5472J	ACTIVE	CDIP	J	14	25	Non-RoHS & Green	SNPB	N / A for Pkg Type	-55 to 125	SN5472J	Samples
SNJ5472J	ACTIVE	CDIP	J	14	25	Non-RoHS & Green	SNPB	N / A for Pkg Type	-55 to 125	SNJ5472J	Samples
SNJ5472J	ACTIVE	CDIP	J	14	25	Non-RoHS & Green	SNPB	N / A for Pkg Type	-55 to 125	SNJ5472J	Samples
SNJ5472W	ACTIVE	CFP	W	14	25	Non-RoHS & Green	SNPB	N / A for Pkg Type	-55 to 125	SNJ5472W	Samples
SNJ5472W	ACTIVE	CFP	W	14	25	Non-RoHS & Green	SNPB	N / A for Pkg Type	-55 to 125	SNJ5472W	Samples

(1) The marketing status values are defined as follows:

ACTIVE: Product device recommended for new designs.

LIFEBUY: TI has announced that the device will be discontinued, and a lifetime-buy period is in effect.

NRND: Not recommended for new designs. Device is in production to support existing customers, but TI does not recommend using this part in a new design.

PREVIEW: Device has been announced but is not in production. Samples may or may not be available.

OBSOLETE: TI has discontinued the production of the device.

(2) **RoHS:** TI defines "RoHS" to mean semiconductor products that are compliant with the current EU RoHS requirements for all 10 RoHS substances, including the requirement that RoHS substance do not exceed 0.1% by weight in homogeneous materials. Where designed to be soldered at high temperatures, "RoHS" products are suitable for use in specified lead-free processes. TI may reference these types of products as "Pb-Free".

RoHS Exempt: TI defines "RoHS Exempt" to mean products that contain lead but are compliant with EU RoHS pursuant to a specific EU RoHS exemption.

Green: TI defines "Green" to mean the content of Chlorine (Cl) and Bromine (Br) based flame retardants meet JS709B low halogen requirements of <=1000ppm threshold. Antimony trioxide based flame retardants must also meet the <=1000ppm threshold requirement.

(3) MSL, Peak Temp. - The Moisture Sensitivity Level rating according to the JEDEC industry standard classifications, and peak solder temperature.

(4) There may be additional marking, which relates to the logo, the lot trace code information, or the environmental category on the device.

(5) Multiple Device Markings will be inside parentheses. Only one Device Marking contained in parentheses and separated by a "~" will appear on a device. If a line is indented then it is a continuation of the previous line and the two combined represent the entire Device Marking for that device.

(6) Lead finish/Ball material - Orderable Devices may have multiple material finish options. Finish options are separated by a vertical ruled line. Lead finish/Ball material values may wrap to two lines if the finish value exceeds the maximum column width.

Important Information and Disclaimer: The information provided on this page represents TI's knowledge and belief as of the date that it is provided. TI bases its knowledge and belief on information provided by third parties, and makes no representation or warranty as to the accuracy of such information. Efforts are underway to better integrate information from third parties. TI has taken and continues to take reasonable steps to provide representative and accurate information but may not have conducted destructive testing or chemical analysis on incoming materials and chemicals. TI and TI suppliers consider certain information to be proprietary, and thus CAS numbers and other limited information may not be available for release.

In no event shall TI's liability arising out of such information exceed the total purchase price of the TI part(s) at issue in this document sold by TI to Customer on an annual basis.

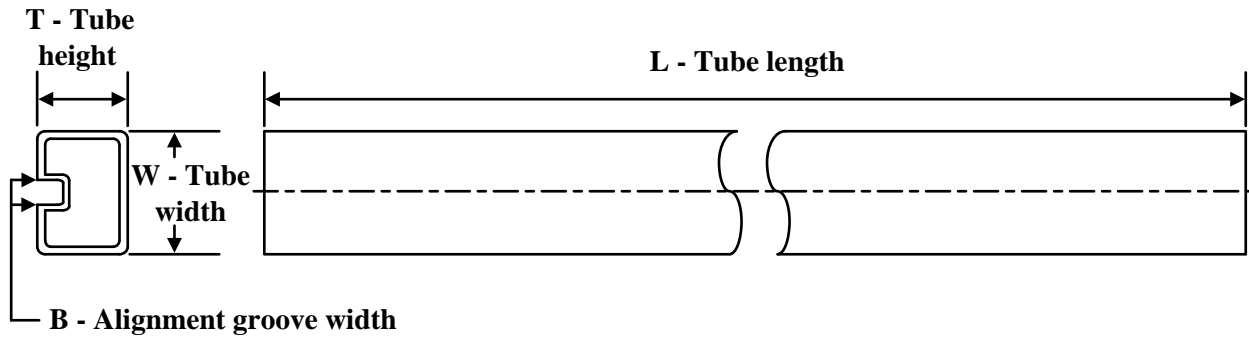
TUBE

*All dimensions are nominal

Device	Package Name	Package Type	Pins	SPQ	L (mm)	W (mm)	T (μm)	B (mm)
SNJ5472W	W	CFP	14	25	506.98	26.16	6220	NA

W (R-GDFP-F14)

CERAMIC DUAL FLATPACK

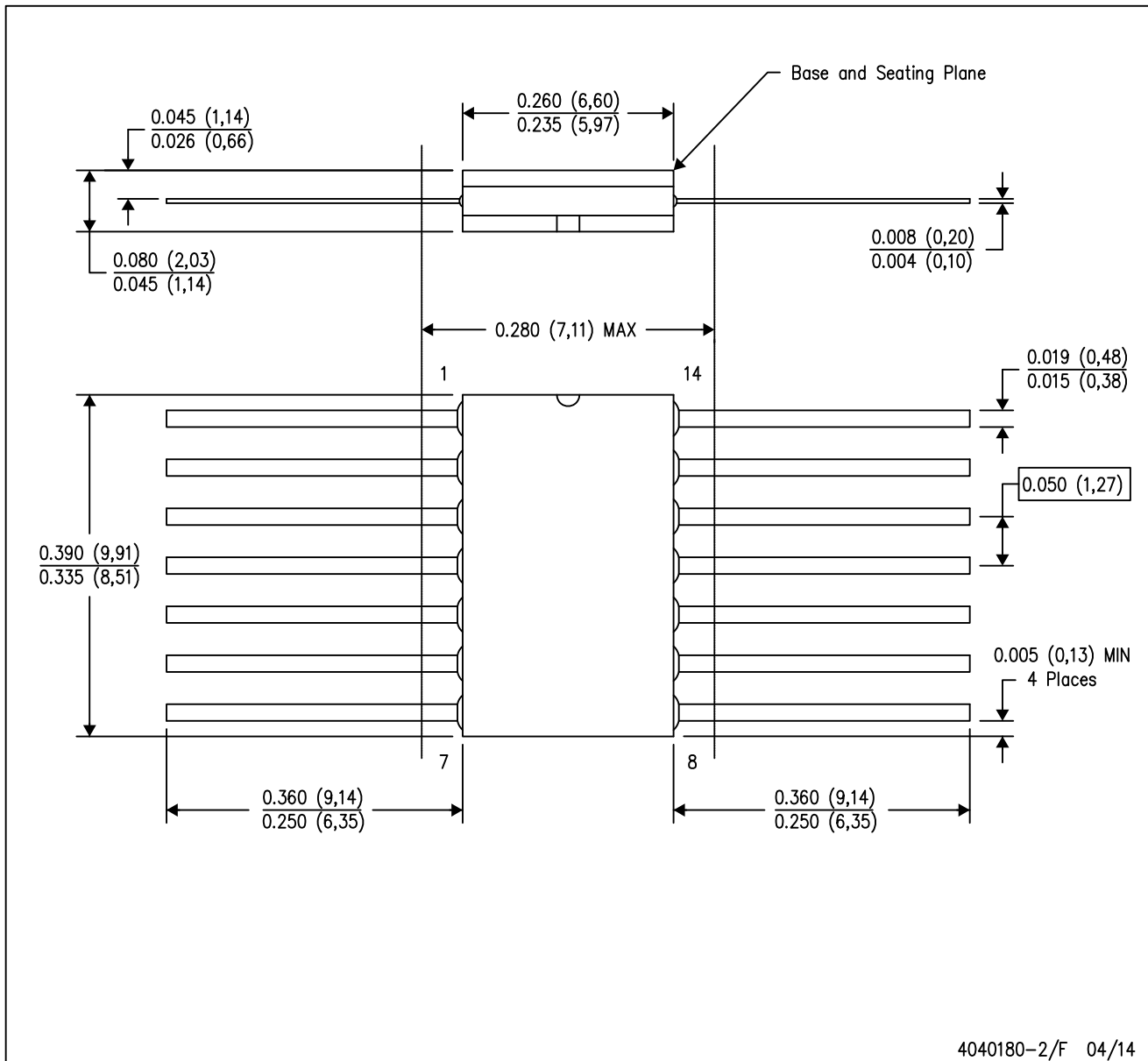

- NOTES:
- A. All linear dimensions are in inches (millimeters).
 - B. This drawing is subject to change without notice.
 - C. This package can be hermetically sealed with a ceramic lid using glass frit.
 - D. Index point is provided on cap for terminal identification only.
 - E. Falls within MIL STD 1835 GDFP1-F14

J 14

GENERIC PACKAGE VIEW
CDIP - 5.08 mm max height
CERAMIC DUAL IN LINE PACKAGE

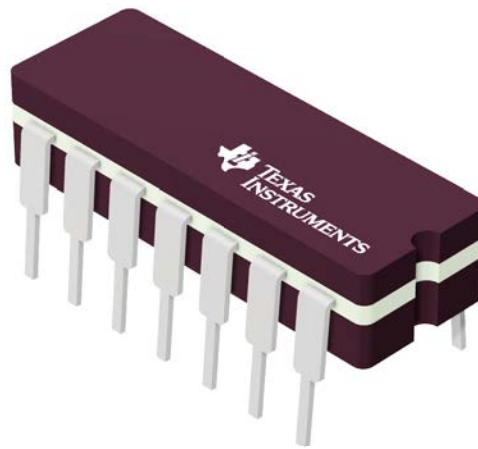

Images above are just a representation of the package family, actual package may vary.
Refer to the product data sheet for package details.

4040083-5/G



J0014A

PACKAGE OUTLINE

CDIP - 5.08 mm max height

CERAMIC DUAL IN LINE PACKAGE

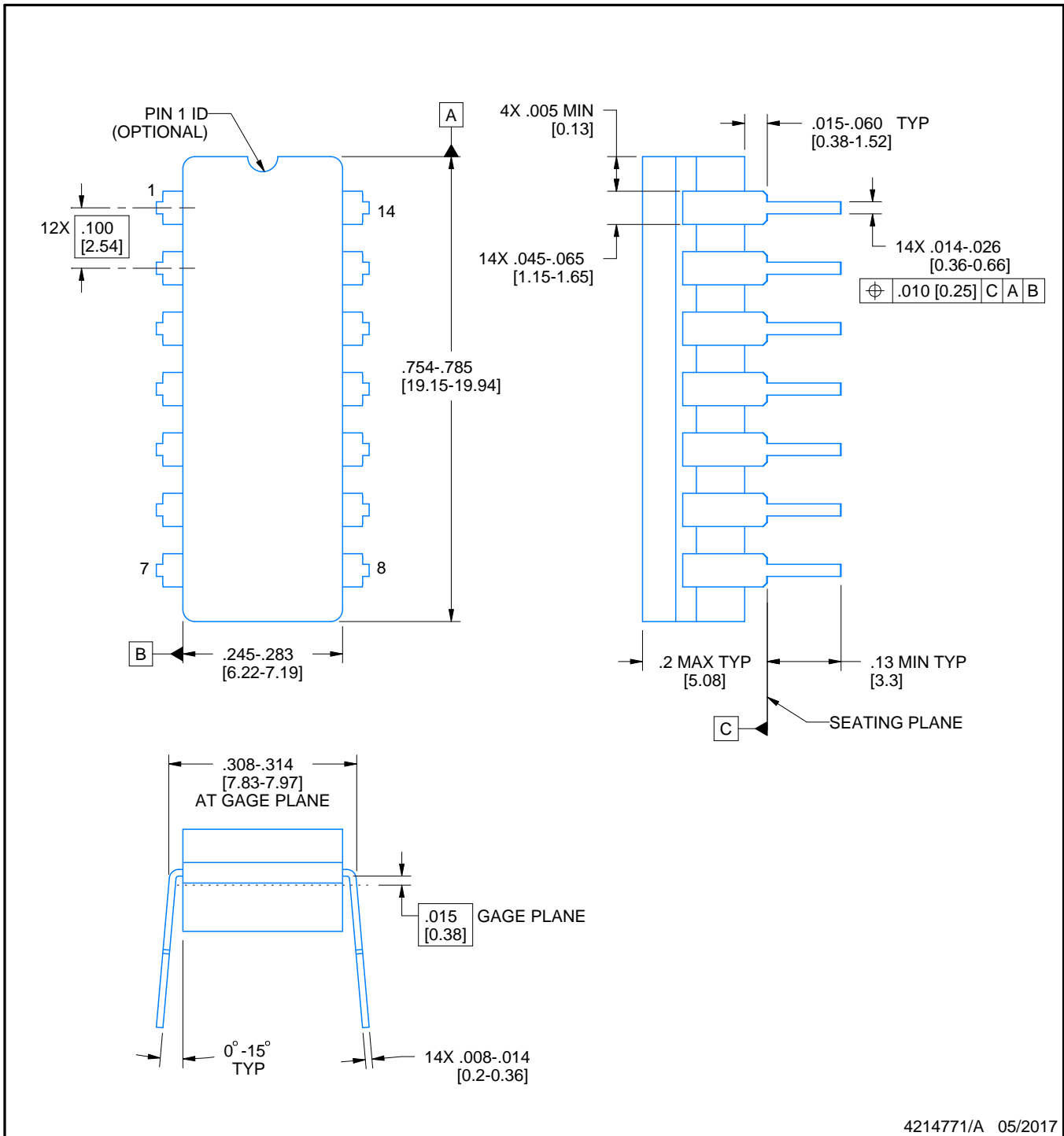

4214771/A 05/2017

NOTES:

1. All controlling linear dimensions are in inches. Dimensions in brackets are in millimeters. Any dimension in brackets or parenthesis are for reference only. Dimensioning and tolerancing per ASME Y14.5M.
2. This drawing is subject to change without notice.
3. This package is hermetically sealed with a ceramic lid using glass frit.
4. Index point is provided on cap for terminal identification only and on press ceramic glass frit seal only.
5. Falls within MIL-STD-1835 and GDIP1-T14.

EXAMPLE BOARD LAYOUT

J0014A

CDIP - 5.08 mm max height

CERAMIC DUAL IN LINE PACKAGE



LAND PATTERN EXAMPLE
NON-SOLDER MASK DEFINED
SCALE: 5X

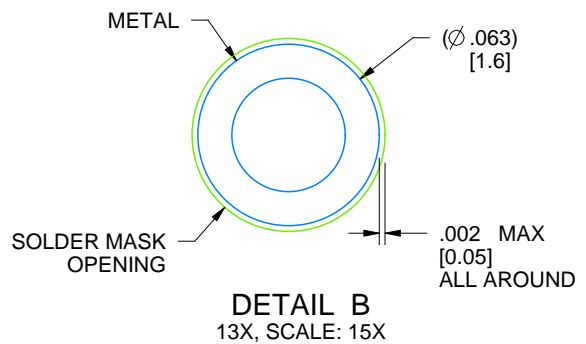

4214771/A 05/2017

IMPORTANT NOTICE AND DISCLAIMER

TI PROVIDES TECHNICAL AND RELIABILITY DATA (INCLUDING DATA SHEETS), DESIGN RESOURCES (INCLUDING REFERENCE DESIGNS), APPLICATION OR OTHER DESIGN ADVICE, WEB TOOLS, SAFETY INFORMATION, AND OTHER RESOURCES "AS IS" AND WITH ALL FAULTS, AND DISCLAIMS ALL WARRANTIES, EXPRESS AND IMPLIED, INCLUDING WITHOUT LIMITATION ANY IMPLIED WARRANTIES OF MERCHANTABILITY, FITNESS FOR A PARTICULAR PURPOSE OR NON-INFRINGEMENT OF THIRD PARTY INTELLECTUAL PROPERTY RIGHTS.

These resources are intended for skilled developers designing with TI products. You are solely responsible for (1) selecting the appropriate TI products for your application, (2) designing, validating and testing your application, and (3) ensuring your application meets applicable standards, and any other safety, security, regulatory or other requirements.

These resources are subject to change without notice. TI grants you permission to use these resources only for development of an application that uses the TI products described in the resource. Other reproduction and display of these resources is prohibited. No license is granted to any other TI intellectual property right or to any third party intellectual property right. TI disclaims responsibility for, and you will fully indemnify TI and its representatives against, any claims, damages, costs, losses, and liabilities arising out of your use of these resources.

TI's products are provided subject to [TI's Terms of Sale](#) or other applicable terms available either on [ti.com](https://www.ti.com) or provided in conjunction with such TI products. TI's provision of these resources does not expand or otherwise alter TI's applicable warranties or warranty disclaimers for TI products.

TI objects to and rejects any additional or different terms you may have proposed.

Mailing Address: Texas Instruments, Post Office Box 655303, Dallas, Texas 75265
Copyright © 2024, Texas Instruments Incorporated

Looking for pricing, stock, or lifecycle information?

Click below to explore more details on WIN SOURCE:

 [View SNJ5472J on WIN SOURCE](#)

 [Texas Instruments](#) Information

Optimize Your Supply Chain with WIN SOURCE Solutions

-  Global Sourcing Solution
-  Obsolete Management
-  Cost Control Management
-  Shortage Management
-  Alternative Solution
-  Excess Inventory Management