



**THE DATASHEET OF  
TRSF3238EIDBR**



## FEATURES

- RS-232 Bus-Pin ESD Protection Exceeds  $\pm 15$  kV Using Human-Body Model (HBM)
- Meets or Exceeds the Requirements of TIA/EIA-232-F and ITU v.28 Standards
- Operates With 3-V to 5.5-V  $V_{CC}$  Supply
- Operates up to 1000 kbit/s
- Five Drivers and Three Receivers
- Auto-Powerdown Plus Feature Enables Flexible Power-Down Mode
- Low Standby Current . . . 1  $\mu$ A Typical
- External Capacitors . . .  $4 \times 0.1 \mu$ F
- Accept 5-V Logic Input With 3.3-V Supply
- Always-Active Noninverting Receiver Output (ROUT1B)
- ESD Protection for RS-232 Interface Pins
  - $\pm 15$ -kV Human-Body Model (HBM)
  - $\pm 8$ -kV IEC61000-4-2, Contact Discharge
  - $\pm 15$ -kV IEC61000-4-2, Air-Gap Discharge

## APPLICATIONS

- Battery-Powered Systems
- PDAs
- Notebooks
- Subnotebooks
- Laptops
- Palmtop PCs
- Hand-Held Equipment
- Modems
- Printers

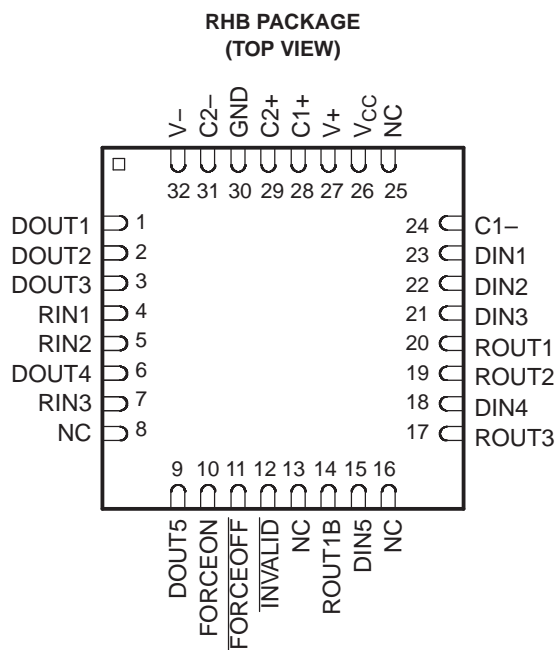
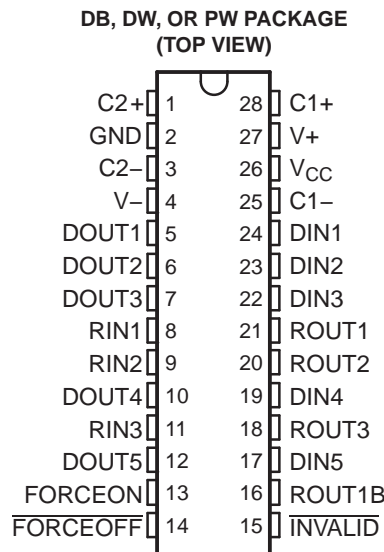

## DESCRIPTION/ORDERING INFORMATION

The TRSF3238E consists of five line drivers, three line receivers, and a dual charge-pump circuit with  $\pm 15$ -kV ESD (HBM) protection on the driver output (DOUT) and receiver input (RIN) terminals. The device meets the requirements of TIA/EIA-232-F and provides the electrical interface between notebook and subnotebook computer applications. The charge pump and four small external capacitors allow operation from a single 3-V to 5.5-V supply. In addition, the device includes an always-active noninverting output (ROUT1B), which allows applications using the ring indicator to transmit data while the device is powered down. The TRSF3238E operates at data signaling rates up to 1000 kbit/s.



Please be aware that an important notice concerning availability, standard warranty, and use in critical applications of Texas Instruments semiconductor products and disclaimers thereto appears at the end of this data sheet.

**TRSF3238E**  
**3-V TO 5.5-V MULTICHANNEL RS-232 LINE DRIVER/RECEIVER**  
**WITH ±15-kV ESD (HBM) PROTECTION**

SLLS826 – AUGUST 2007

**DESCRIPTION/ORDERING INFORMATION (CONTINUED)**

Flexible control options for power management are featured when the serial port and driver inputs are inactive. The auto-powerdown plus feature functions when FORCEON is low and FORCEOFF is high. During this mode of operation, if the device does not sense valid signal transitions on all receiver and driver inputs for approximately 30 s, the built-in charge pump and drivers are powered down, reducing the supply current to 1 µA. By disconnecting the serial port or placing the peripheral drivers off, auto-powerdown plus occurs if there is no activity in the logic levels for the driver inputs. Auto-powerdown plus can be disabled when FORCEON and FORCEOFF are high. With auto-powerdown plus enabled, the device activates automatically when a valid signal is applied to any receiver or driver input. INVALID is high (valid data) if any receiver input voltage is greater than 2.7 V or less than -2.7 V, or has been between -0.3 V and 0.3 V for less than 30 µs. INVALID is low (invalid data) if all receiver input voltages are between -0.3 V and 0.3 V for more than 30 µs. Refer to Figure 5 for receiver input levels.

**ORDERING INFORMATION**

T <sub>A</sub>	PACKAGE <sup>(1)(2)</sup>		ORDERABLE PART NUMBER	TOP-SIDE MARKING
0°C to 70°C	QFN – RHB	Reel of 2000	TRSF3238ECRHBR	RS38EC
	SOIC – DW	Tube of 50	TRSF3238ECDW	TRS3238EC
		Reel of 2000	TRSF3238ECDWR	
	SSOP – DB	Tube of 50	TRSF3238ECDB	TRS3238EC
		Reel of 2000	TRSF3238ECDBR	
	TSSOP – PW	Tube of 50	TRSF3238ECPW	RS38EC
		Reel of 2000	TRSF3238ECPWR	
	-40°C to 85°C	QFN – RHB	Reel of 2000	TRSF3238EIRHBR
SOIC – DW		Tube of 50	TRSF3238EIDW	TRS3238EI
		Reel of 2000	TRSF3238EIDWR	
SSOP – DB		Tube of 50	TRSF3238EIDB	TRS3238EI
		Reel of 2000	TRSF3238EIDBR	
TSSOP – PW		Tube of 50	TRSF3238EIPW	RS38EI
		Reel of 2000	TRSF3238EIPWR	

(1) Package drawings, thermal data, and symbolization are available at [www.ti.com/packaging](http://www.ti.com/packaging).

(2) For the most current package and ordering information, see the Package Option Addendum at the end of this document, or see the TI website at [www.ti.com](http://www.ti.com).

**FUNCTION TABLES**
**Each Driver<sup>(1)</sup>**

INPUTS				OUTPUT DOUT	DRIVER STATUS
DIN	FORCEON	$\overline{\text{FORCEOFF}}$	TIME ELAPSED SINCE LAST RIN OR DIN TRANSITION		
X	X	L	X	Z	Powered off
L	H	H	X	H	Normal operation with auto-powerdown plus disabled
H	H	H	X	L	
L	L	H	<30 s	H	Normal operation with auto-powerdown plus enabled
H	L	H	<30 s	L	
L	L	H	>30 s	Z	Powered off by auto-powerdown plus feature
H	L	H	>30 s	Z	

(1) H = high level, L = low level, X = irrelevant, Z = high impedance

**Each Receiver<sup>(1)</sup>**

INPUTS				OUTPUTS		RECEIVER STATUS
RIN1	RIN2 AND RIN3	$\overline{\text{FORCEOFF}}$	TIME ELAPSED SINCE LAST RIN OR DIN TRANSITION	ROUT1B	ROUT2 AND ROUT3	
L	X	L	X	L	Z	Powered off while ROUT1B is active
H	X	L	X	H	Z	
L	L	H	<30 s	L	H	Normal operation with auto-powerdown plus disabled/enabled
L	H	H	<30 s	L	L	
H	L	H	<30 s	H	H	
H	H	H	<30 s	H	L	
Open	Open	H	<30 s	L	H	

(1) H = high level, L = low level, X = irrelevant, Z = high impedance (off), Open = input disconnected or connected driver off

**TRSF3238E**  
**3-V TO 5.5-V MULTICHANNEL RS-232 LINE DRIVER/RECEIVER**  
**WITH  $\pm 15$ -kV ESD (HBM) PROTECTION**

SLLS826–AUGUST 2007

**LOGIC DIAGRAM (POSITIVE LOGIC)**

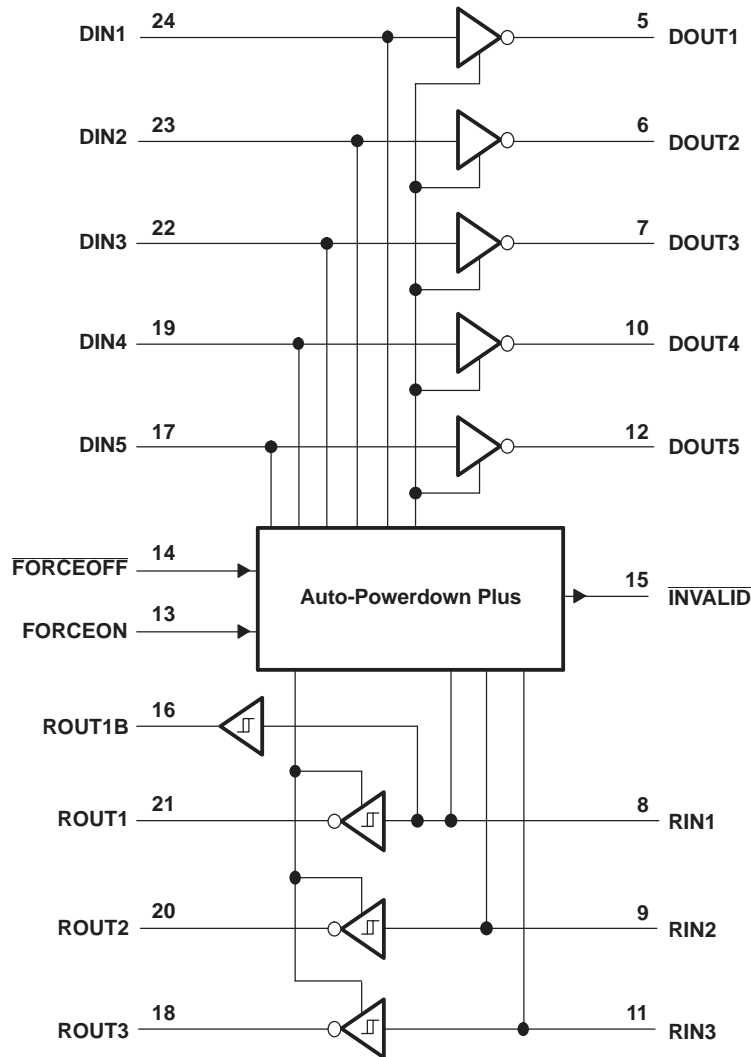

## Absolute Maximum Ratings<sup>(1)</sup>

over operating free-air temperature range (unless otherwise noted)

		MIN	MAX	UNIT	
V <sub>CC</sub>	Supply voltage range <sup>(2)</sup>	–0.3	6	V	
V+	Positive-output supply voltage range <sup>(2)</sup>	–0.3	7	V	
V–	Negative-output supply voltage range <sup>(2)</sup>	0.3	–7	V	
V+ – V–	Supply voltage difference <sup>(2)</sup>		13	V	
V <sub>I</sub>	Input voltage range	Driver (FORCEOFF, FORCEON)	–0.3	6	V
		Receiver	–25	25	
V <sub>O</sub>	Output voltage range	Driver	–13.2	13.2	V
		Receiver (INVALID)	–0.3	V <sub>CC</sub> + 0.3	
$\theta_{JA}$	Package thermal impedance <sup>(3)(4)</sup>	DB package		62	°C/W
		DW package		46	
		PW package		62	
		RHB package		TBD	
T <sub>J</sub>	Operating virtual junction temperature		150	°C	
T <sub>stg</sub>	Storage temperature range	–65	150	°C	

- Stresses beyond those listed under "absolute maximum ratings" may cause permanent damage to the device. These are stress ratings only, and functional operation of the device at these or any other conditions beyond those indicated under "recommended operating conditions" is not implied. Exposure to absolute-maximum-rated conditions for extended periods may affect device reliability.
- All voltages are with respect to network GND.
- Maximum power dissipation is a function of T<sub>J</sub>(max),  $\theta_{JA}$ , and T<sub>A</sub>. The maximum allowable power dissipation at any allowable ambient temperature is P<sub>D</sub> = (T<sub>J</sub>(max) – T<sub>A</sub>)/ $\theta_{JA}$ . Operating at the absolute maximum T<sub>J</sub> of 150°C can affect reliability.
- The package thermal impedance is calculated in accordance with JESD 51-7.

## Recommended Operating Conditions<sup>(1)</sup>

See Figure 6

		MIN	NOM	MAX	UNIT
Supply voltage	V <sub>CC</sub> = 3.3 V	3	3.3	3.6	V
	V <sub>CC</sub> = 5 V	4.5	5	5.5	
V <sub>IH</sub> Driver and control high-level input voltage	DIN, FORCEOFF, FORCEON	V <sub>CC</sub> = 3.3 V	2	5.5	V
		V <sub>CC</sub> = 5 V	2.4	5.5	
V <sub>IL</sub> Driver and control low-level input voltage	DIN, FORCEOFF, FORCEON	0		0.8	V
V <sub>I</sub> Receiver input voltage		–25		25	V
T <sub>A</sub> Operating free-air temperature	TRSF3238EC	0		70	°C
	TRSF3238EI	–40		85	

- Testing supply conditions are C1–C4 = 0.1  $\mu$ F at V<sub>CC</sub> = 3.3 V  $\pm$  0.15 V; C1–C4 = 0.22  $\mu$ F at V<sub>CC</sub> = 3.3 V  $\pm$  0.3 V; and C1 = 0.047  $\mu$ F and C2–C4 = 0.33  $\mu$ F at V<sub>CC</sub> = 5 V  $\pm$  0.5 V.

## Electrical Characteristics<sup>(1)</sup>

over recommended ranges of supply voltage and operating free-air temperature (unless otherwise noted) (see Figure 6)

PARAMETER		TEST CONDITIONS	MIN	TYP <sup>(2)</sup>	MAX	UNIT
I <sub>I</sub>	Input leakage current	FORCEOFF, FORCEON		$\pm 0.01$	$\pm 1$	$\mu$ A
I <sub>CC</sub>	Supply current (T <sub>A</sub> = 25°C)	Auto-powerdown plus disabled	No load, FORCEOFF and FORCEON at V <sub>CC</sub> , V <sub>CC</sub> at 3.3 V or 5 V	0.5	2	mA
		Powered off	No load, FORCEOFF at GND	1	10	$\mu$ A
		Auto-powerdown plus enabled	No load, FORCEOFF at V <sub>CC</sub> , FORCEON at GND, All RIN are open or grounded	1	10	

- Testing supply conditions are C1–C4 = 0.1  $\mu$ F at V<sub>CC</sub> = 3.3 V  $\pm$  0.15 V; C1–C4 = 0.22  $\mu$ F at V<sub>CC</sub> = 3.3 V  $\pm$  0.3 V; and C1 = 0.047  $\mu$ F and C2–C4 = 0.33  $\mu$ F at V<sub>CC</sub> = 5 V  $\pm$  0.5 V.
- All typical values are at V<sub>CC</sub> = 3.3 V or V<sub>CC</sub> = 5 V, and T<sub>A</sub> = 25°C.

**TRSF3238E**  
**3-V TO 5.5-V MULTICHANNEL RS-232 LINE DRIVER/RECEIVER**  
**WITH ±15-kV ESD (HBM) PROTECTION**

SLLS826–AUGUST 2007

**DRIVER SECTION**

**Electrical Characteristics<sup>(1)</sup>**

over recommended ranges of supply voltage and operating free-air temperature (unless otherwise noted) (see [Figure 6](#))

PARAMETER	TEST CONDITIONS		MIN	TYP <sup>(2)</sup>	MAX	UNIT
V <sub>OH</sub>	High-level output voltage	All DOUT at R <sub>L</sub> = 3 kΩ to GND	5	5.4		V
V <sub>OL</sub>	Low-level output voltage	All DOUT at R <sub>L</sub> = 3 kΩ to GND	–5	–5.4		V
I <sub>IH</sub>	High-level input current	V <sub>I</sub> = V <sub>CC</sub>		±0.01	±1	μA
I <sub>IL</sub>	Low-level input current	V <sub>I</sub> at GND		±0.01	±1	μA
I <sub>OS</sub>	Short-circuit output current <sup>(3)</sup>	V <sub>O</sub> = 0 V		±35	±60	mA
		V <sub>CC</sub> = 3.6 V				
		V <sub>CC</sub> = 5.5 V		±40	±100	
r <sub>o</sub>	Output resistance	V <sub>CC</sub> , V+, and V– = 0 V, V <sub>O</sub> = ±2 V	300	10M		Ω
I <sub>OZ</sub>	Output leakage current	FORCEOFF = GND			±25	μA
		V <sub>O</sub> = ±12 V, V <sub>CC</sub> = 3 V to 3.6 V				
		V <sub>O</sub> = ±10 V, V <sub>CC</sub> = 4.5 V to 5.5 V			±25	

(1) Testing supply conditions are C1–C4 = 0.1 μF at V<sub>CC</sub> = 3.3 V ± 0.15 V; C1–C4 = 0.22 μF at V<sub>CC</sub> = 3.3 V ± 0.3 V; and C1 = 0.047 μF and C2–C4 = 0.33 μF at V<sub>CC</sub> = 5 V ± 0.5 V.

(2) All typical values are at V<sub>CC</sub> = 3.3 V or V<sub>CC</sub> = 5 V, and T<sub>A</sub> = 25°C.

(3) Short-circuit durations should be controlled to prevent exceeding the device absolute power dissipation ratings, and not more than one output should be shorted at a time.

**Switching Characteristics<sup>(1)</sup>**

over recommended ranges of supply voltage and operating free-air temperature (unless otherwise noted) (see [Figure 6](#))

PARAMETER	TEST CONDITIONS		MIN	TYP <sup>(2)</sup>	MAX	UNIT
Maximum data rate (see <a href="#">Figure 1</a> )	R <sub>L</sub> = 3 kΩ, One DOUT switching	C <sub>L</sub> = 1000 pF		250		kbit/s
		C <sub>L</sub> = 250 pF, V <sub>CC</sub> = 3 V to 4.5 V		1000		
		C <sub>L</sub> = 1000 pF, V <sub>CC</sub> = 4.5 V to 5.5 V		1000		
t <sub>sk(p)</sub>	Pulse skew <sup>(3)</sup>	C <sub>L</sub> = 150 pF to 2500 pF, R <sub>L</sub> = 3 kΩ to 7 kΩ, See <a href="#">Figure 2</a>		25		ns
SR(tr)	Slew rate, transition region (see <a href="#">Figure 1</a> )	C <sub>L</sub> = 150 pF to 1000 pF, R <sub>L</sub> = 3 kΩ to 7 kΩ, V <sub>CC</sub> = 3.3 V		18	150	V/μs

(1) Testing supply conditions are C1–C4 = 0.1 μF at V<sub>CC</sub> = 3.3 V ± 0.15 V; C1–C4 = 0.22 μF at V<sub>CC</sub> = 3.3 V ± 0.3 V; and C1 = 0.047 μF and C2–C4 = 0.33 μF at V<sub>CC</sub> = 5 V ± 0.5 V.

(2) All typical values are at V<sub>CC</sub> = 3.3 V or V<sub>CC</sub> = 5 V, and T<sub>A</sub> = 25°C.

(3) Pulse skew is defined as |t<sub>PLH</sub> – t<sub>PHL</sub>| of each channel of the same device.

**ESD Protection**

PARAMETER	TEST CONDITIONS	TYP	UNIT
DOUT	HBM	±15	kV
	IEC 61000-4-2, Air-Gap Discharge	±15	
	IEC 61000-4-2, Contact Discharge	±8	

## RECEIVER SECTION

### Electrical Characteristics<sup>(1)</sup>

over recommended ranges of supply voltage and operating free-air temperature (unless otherwise noted) (see [Figure 6](#))

PARAMETER		TEST CONDITIONS	MIN	TYP <sup>(2)</sup>	MAX	UNIT
V <sub>OH</sub>	High-level output voltage	I <sub>OH</sub> = -1 mA	V <sub>CC</sub> - 0.6	V <sub>CC</sub> - 0.1		V
V <sub>OL</sub>	Low-level output voltage	I <sub>OL</sub> = 1.6 mA			0.4	V
V <sub>IT+</sub>	Positive-going input threshold voltage	V <sub>CC</sub> = 3.3 V		1.5	2.4	V
		V <sub>CC</sub> = 5 V		1.8	2.4	
V <sub>IT-</sub>	Negative-going input threshold voltage	V <sub>CC</sub> = 3.3 V	0.6	1.2		V
		V <sub>CC</sub> = 5 V	0.8	1.5		
V <sub>hys</sub>	Input hysteresis (V <sub>IT+</sub> - V <sub>IT-</sub> )			0.3		V
I <sub>OZ</sub>	Output leakage current (except ROUT1B)	FORCEOFF = 0 V		±0.05	±10	µA
r <sub>i</sub>	Input resistance	V <sub>i</sub> = ±3 V to ±25 V	3	5	7	kΩ

(1) Testing supply conditions are C1–C4 = 0.1 µF at V<sub>CC</sub> = 3.3 V ± 0.15 V; C1–C4 = 0.22 µF at V<sub>CC</sub> = 3.3 V ± 0.3 V; and C1 = 0.047 µF and C2–C4 = 0.33 µF at V<sub>CC</sub> = 5 V ± 0.5 V.

(2) All typical values are at V<sub>CC</sub> = 3.3 V or V<sub>CC</sub> = 5 V, and T<sub>A</sub> = 25°C.

### Switching Characteristics<sup>(1)</sup>

over recommended ranges of supply voltage and operating free-air temperature (unless otherwise noted)

PARAMETER		TEST CONDITIONS	TYP <sup>(2)</sup>	UNIT
t <sub>PLH</sub>	Propagation delay time, low- to high-level output	C <sub>L</sub> = 150 pF, See <a href="#">Figure 3</a>	150	ns
t <sub>PHL</sub>	Propagation delay time, high- to low-level output	C <sub>L</sub> = 150 pF, See <a href="#">Figure 3</a>	150	ns
t <sub>en</sub>	Output enable time	C <sub>L</sub> = 150 pF, R <sub>L</sub> = 3 kΩ, See <a href="#">Figure 4</a>	200	ns
t <sub>dis</sub>	Output disable time	C <sub>L</sub> = 150 pF, R <sub>L</sub> = 3 kΩ, See <a href="#">Figure 4</a>	200	ns
t <sub>sk(p)</sub>	Pulse skew <sup>(3)</sup>	See <a href="#">Figure 3</a>	50	ns

(1) Testing supply conditions are C1–C4 = 0.1 µF at V<sub>CC</sub> = 3.3 V ± 0.15 V; C1–C4 = 0.22 µF at V<sub>CC</sub> = 3.3 V ± 0.3 V; and C1 = 0.047 µF and C2–C4 = 0.33 µF at V<sub>CC</sub> = 5 V ± 0.5 V.

(2) All typical values are at V<sub>CC</sub> = 3.3 V or V<sub>CC</sub> = 5 V, and T<sub>A</sub> = 25°C.

(3) Pulse skew is defined as |t<sub>PLH</sub> - t<sub>PHL</sub>| of each channel of the same device.

## ESD Protection

PARAMETER	TEST CONDITIONS	TYP	UNIT
RIN	HBM	±15	kV
	IEC 61000-4-2, Air-Gap Discharge	±15	
	IEC 61000-4-2, Contact Discharge	±8	

**TRSF3238E**  
**3-V TO 5.5-V MULTICHANNEL RS-232 LINE DRIVER/RECEIVER**  
**WITH  $\pm 15$ -kV ESD (HBM) PROTECTION**

SLLS826–AUGUST 2007

**AUTO-POWERDOWN PLUS SECTION**

**Electrical Characteristics**

over recommended ranges of supply voltage and operating free-air temperature (unless otherwise noted) (see [Figure 5](#))

PARAMETER		TEST CONDITIONS	MIN	MAX	UNIT
$V_{T+(valid)}$	Receiver input threshold for $\overline{INVALID}$ high-level output voltage	FORCEON = GND, $\overline{FORCEOFF} = V_{CC}$		2.7	V
$V_{T-(valid)}$	Receiver input threshold for $\overline{INVALID}$ high-level output voltage	FORCEON = GND, $\overline{FORCEOFF} = V_{CC}$	-2.7		V
$V_{T(invalid)}$	Receiver input threshold for $\overline{INVALID}$ low-level output voltage	FORCEON = GND, $\overline{FORCEOFF} = V_{CC}$	-0.3	0.3	V
$V_{OH}$	$\overline{INVALID}$ high-level output voltage	$I_{OH} = -1$ mA, FORCEON = GND, $\overline{FORCEOFF} = V_{CC}$	$V_{CC} - 0.6$		V
$V_{OL}$	$\overline{INVALID}$ low-level output voltage	$I_{OL} = 1.6$ mA, FORCEON = GND, $\overline{FORCEOFF} = V_{CC}$		0.4	V

**Switching Characteristics**

over recommended ranges of supply voltage and operating free-air temperature (unless otherwise noted) (see [Figure 5](#))

PARAMETER		MIN	TYP <sup>(1)</sup>	MAX	UNIT
$t_{valid}$	Propagation delay time, low- to high-level output		0.1		$\mu$ s
$t_{invalid}$	Propagation delay time, high- to low-level output		50		$\mu$ s
$t_{en}$	Supply enable time		25		$\mu$ s
$t_{dis}$	Receiver or driver edge to auto-powerdown plus	15	30	60	s

(1) All typical values are at  $V_{CC} = 3.3$  V or  $V_{CC} = 5$  V, and  $T_A = 25^\circ\text{C}$ .

PARAMETER MEASUREMENT INFORMATION

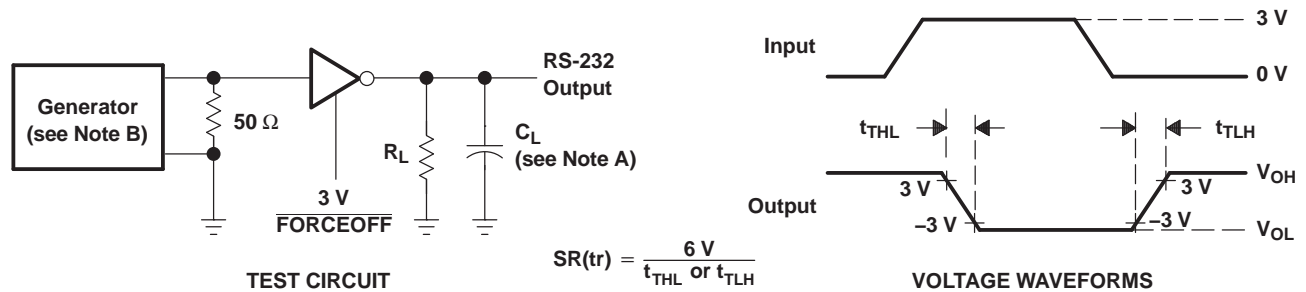

- A. C<sub>L</sub> includes probe and jig capacitance.
- B. The pulse generator has the following characteristics: PRR = 250 kbit/s, Z<sub>O</sub> = 50 Ω, 50% duty cycle, t<sub>r</sub> ≤ 10 ns, t<sub>f</sub> ≤ 10 ns.

Figure 1. Driver Slew Rate

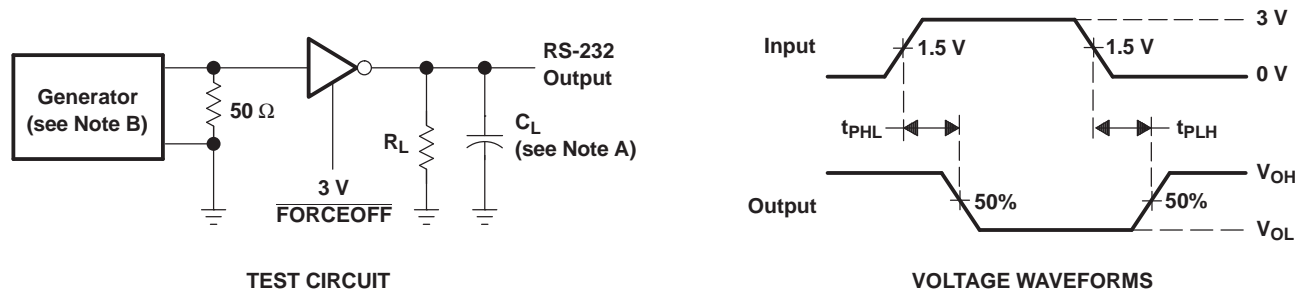

- A. C<sub>L</sub> includes probe and jig capacitance.
- B. The pulse generator has the following characteristics: PRR = 250 kbit/s, Z<sub>O</sub> = 50 Ω, 50% duty cycle, t<sub>r</sub> ≤ 10 ns, t<sub>f</sub> ≤ 10 ns.

Figure 2. Driver Pulse Skew

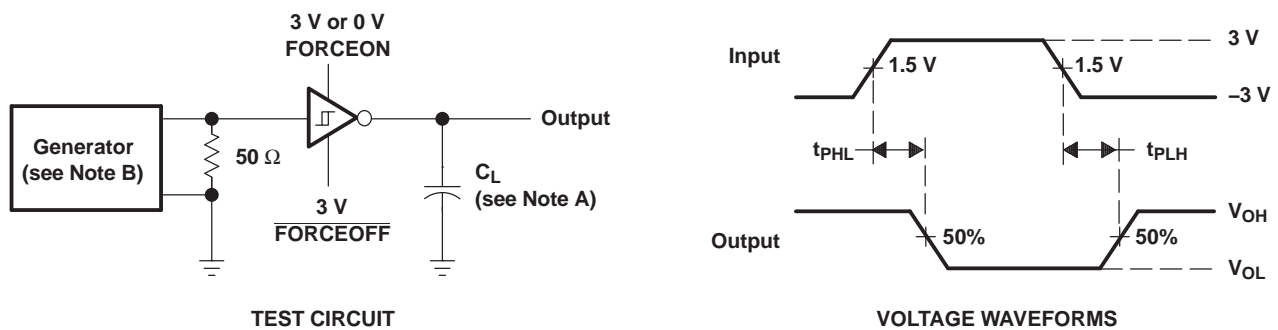

- A. C<sub>L</sub> includes probe and jig capacitance.
- B. The pulse generator has the following characteristics: Z<sub>O</sub> = 50 Ω, 50% duty cycle, t<sub>r</sub> ≤ 10 ns, t<sub>f</sub> ≤ 10 ns.

Figure 3. Receiver Propagation Delay Times

PARAMETER MEASUREMENT INFORMATION (continued)

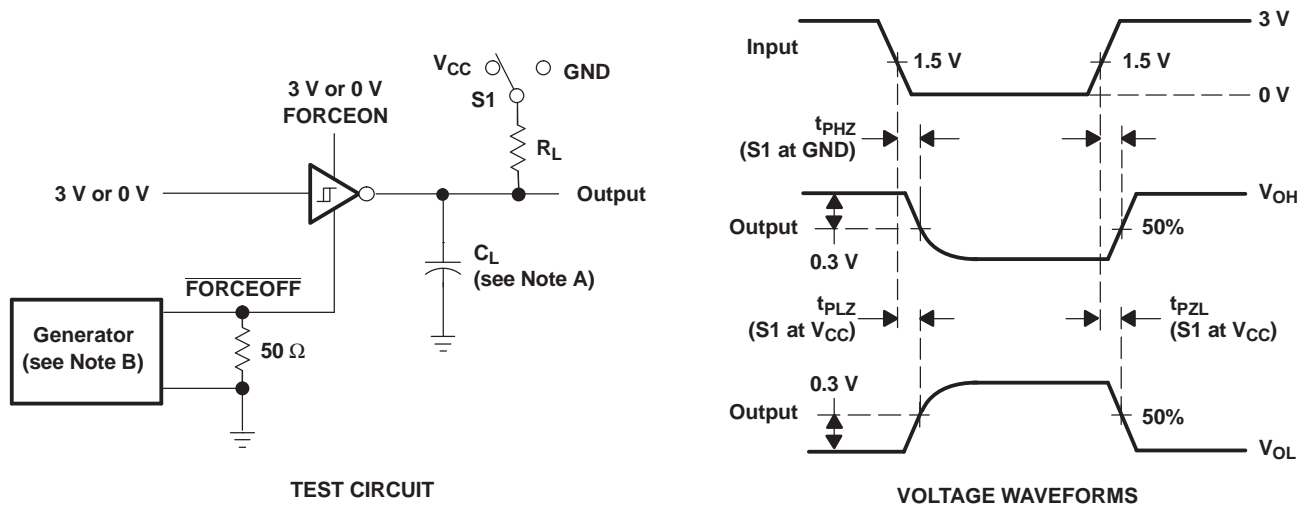

- A.  $C_L$  includes probe and jig capacitance.
- B. The pulse generator has the following characteristics:  $Z_O = 50 \Omega$ , 50% duty cycle,  $t_r \leq 10$  ns,  $t_f \leq 10$  ns.
- C.  $t_{PLZ}$  and  $t_{PHZ}$  are the same as  $t_{dis}$ .
- D.  $t_{PZL}$  and  $t_{PZH}$  are the same as  $t_{en}$ .

Figure 4. Receiver Enable and Disable Times

PARAMETER MEASUREMENT INFORMATION (continued)

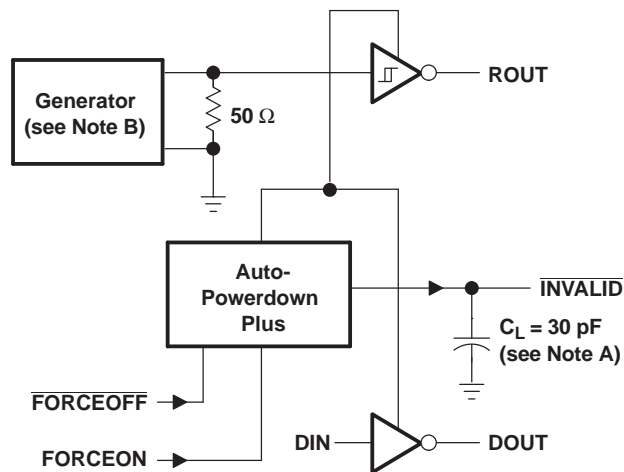

TEST CIRCUIT

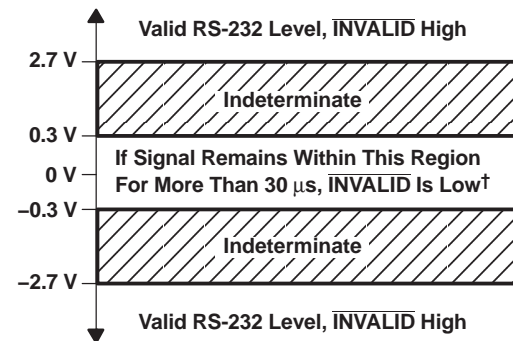

† Auto-powerdown plus disables drivers and reduces supply current to 1  $\mu$ A.

- NOTES: A.  $C_L$  includes probe and jig capacitance.  
B. The pulse generator has the following characteristics: PRR = 5 kbit/s,  $Z_O = 50 \Omega$ , 50% duty cycle,  $t_r \leq 10$  ns,  $t_f \leq 10$  ns.

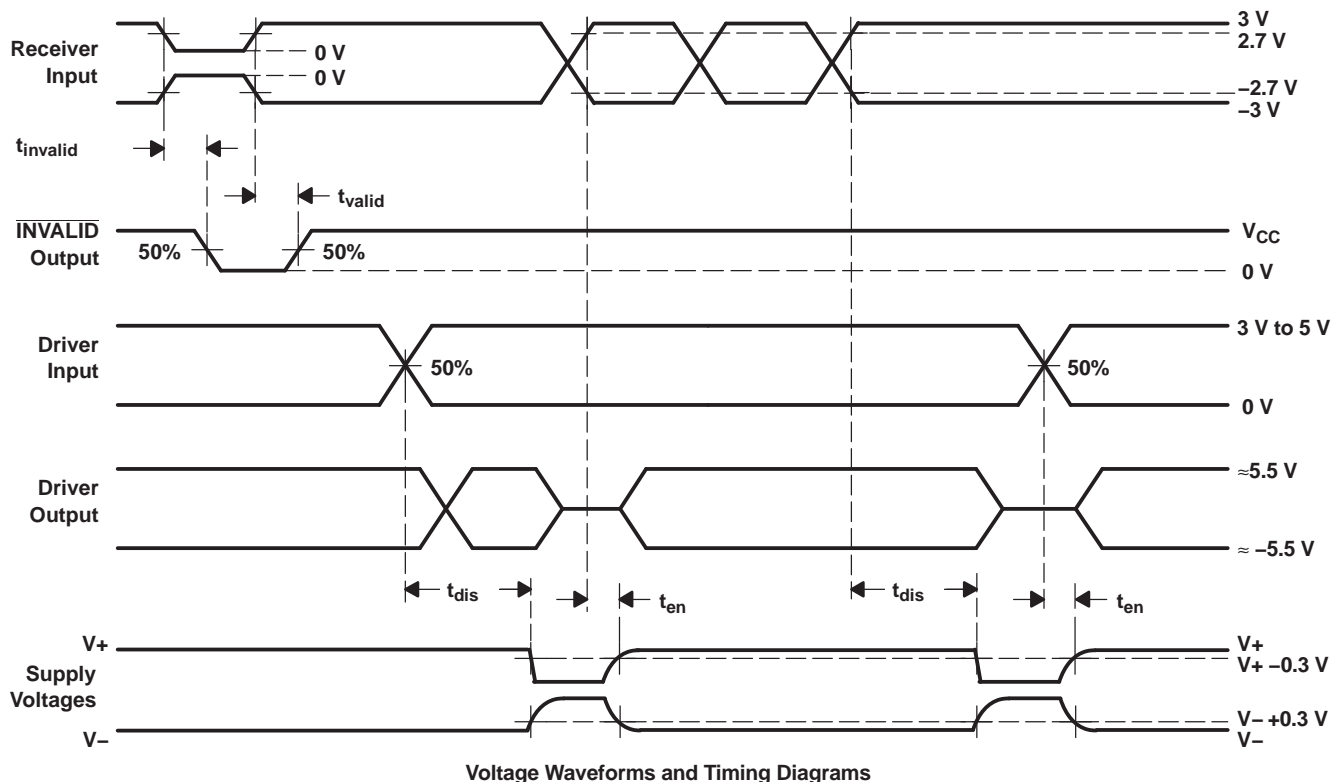
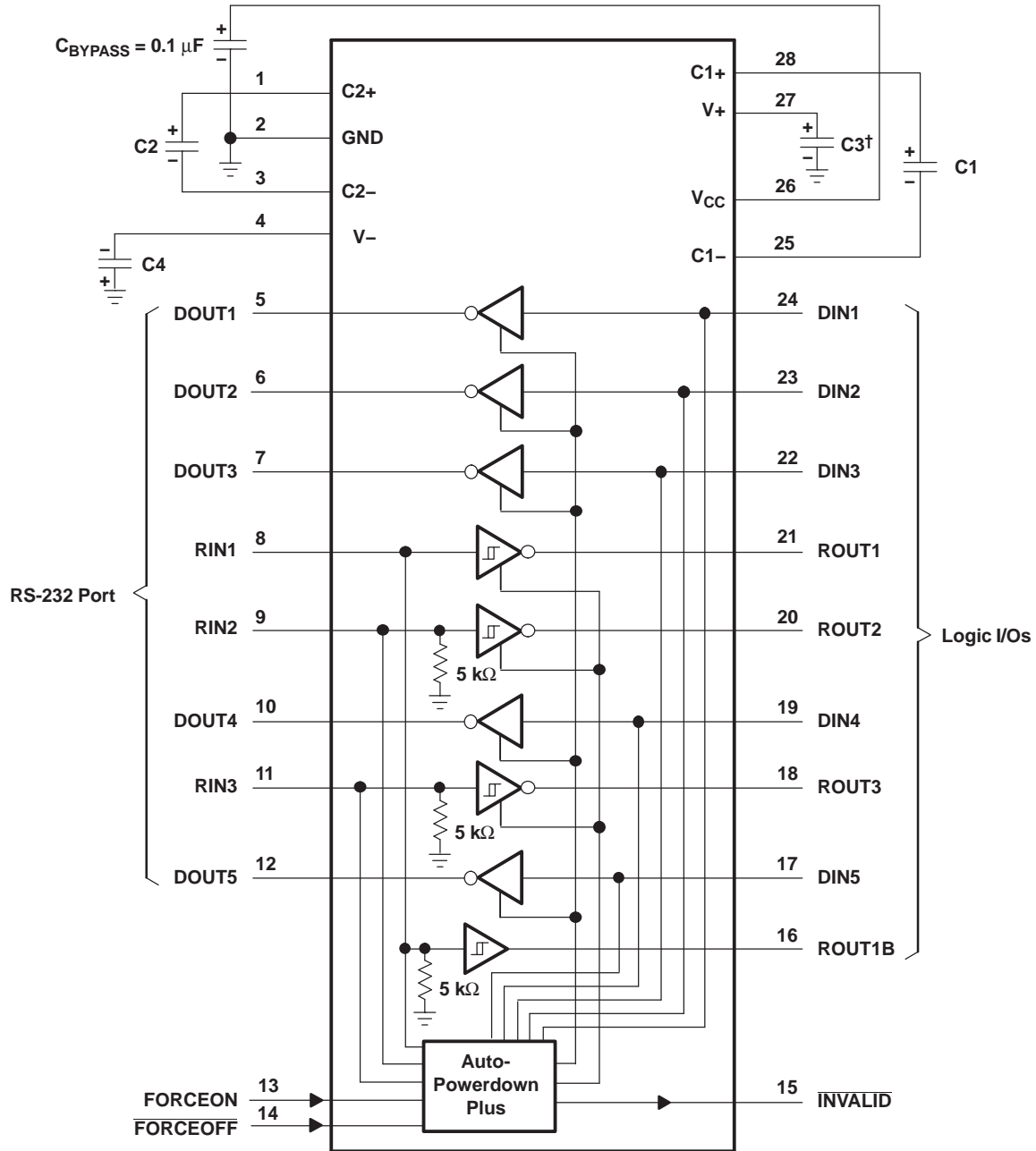

Figure 5.  $\overline{\text{INVALID}}$  Propagation-Delay Times and Supply-Enabling Time

**APPLICATION INFORMATION**



**V<sub>CC</sub> vs CAPACITOR VALUES**

V <sub>CC</sub>	C1	C2, C3, and C4
3.3 V ± 0.15 V	0.1 μF	0.1 μF
3.3 V ± 0.3 V	0.22 μF	0.22 μF
5 V ± 0.5 V	0.047 μF	0.33 μF
3 V to 5.5 V	0.22 μF	1 μF

† C3 can be connected to V<sub>CC</sub> or GND.

NOTES: A. Resistor values shown are nominal.

B. Nonpolarized ceramic capacitors are acceptable. If polarized tantalum or electrolytic capacitors are used, they should be connected as shown.

**Figure 6. Typical Operating Circuit and Capacitor Values**

**PACKAGING INFORMATION**

Orderable Device	Status (1)	Package Type	Package Drawing	Pins	Package Qty	Eco Plan (2)	Lead finish/ Ball material (6)	MSL Peak Temp (3)	Op Temp (°C)	Device Marking (4/5)	Samples
TRSF3238EIDBR	ACTIVE	SSOP	DB	28	2000	RoHS & Green	NIPDAU	Level-1-260C-UNLIM	-40 to 85	TRSF3238EI	<a href="#">Samples</a>
TRSF3238EIDWR	ACTIVE	SOIC	DW	28	1000	RoHS & Green	NIPDAU	Level-1-260C-UNLIM	-40 to 85	TRSF3238EI	<a href="#">Samples</a>

(1) The marketing status values are defined as follows:

**ACTIVE:** Product device recommended for new designs.

**LIFEBUY:** TI has announced that the device will be discontinued, and a lifetime-buy period is in effect.

**NRND:** Not recommended for new designs. Device is in production to support existing customers, but TI does not recommend using this part in a new design.

**PREVIEW:** Device has been announced but is not in production. Samples may or may not be available.

**OBSELETE:** TI has discontinued the production of the device.

(2) **RoHS:** TI defines "RoHS" to mean semiconductor products that are compliant with the current EU RoHS requirements for all 10 RoHS substances, including the requirement that RoHS substance do not exceed 0.1% by weight in homogeneous materials. Where designed to be soldered at high temperatures, "RoHS" products are suitable for use in specified lead-free processes. TI may reference these types of products as "Pb-Free".

**RoHS Exempt:** TI defines "RoHS Exempt" to mean products that contain lead but are compliant with EU RoHS pursuant to a specific EU RoHS exemption.

**Green:** TI defines "Green" to mean the content of Chlorine (Cl) and Bromine (Br) based flame retardants meet JS709B low halogen requirements of <=1000ppm threshold. Antimony trioxide based flame retardants must also meet the <=1000ppm threshold requirement.

(3) MSL, Peak Temp. - The Moisture Sensitivity Level rating according to the JEDEC industry standard classifications, and peak solder temperature.

(4) There may be additional marking, which relates to the logo, the lot trace code information, or the environmental category on the device.

(5) Multiple Device Markings will be inside parentheses. Only one Device Marking contained in parentheses and separated by a "~" will appear on a device. If a line is indented then it is a continuation of the previous line and the two combined represent the entire Device Marking for that device.

(6) Lead finish/Ball material - Orderable Devices may have multiple material finish options. Finish options are separated by a vertical ruled line. Lead finish/Ball material values may wrap to two lines if the finish value exceeds the maximum column width.

**Important Information and Disclaimer:**The information provided on this page represents TI's knowledge and belief as of the date that it is provided. TI bases its knowledge and belief on information provided by third parties, and makes no representation or warranty as to the accuracy of such information. Efforts are underway to better integrate information from third parties. TI has taken and continues to take reasonable steps to provide representative and accurate information but may not have conducted destructive testing or chemical analysis on incoming materials and chemicals. TI and TI suppliers consider certain information to be proprietary, and thus CAS numbers and other limited information may not be available for release.

In no event shall TI's liability arising out of such information exceed the total purchase price of the TI part(s) at issue in this document sold by TI to Customer on an annual basis.



**TAPE AND REEL INFORMATION**

**QUADRANT ASSIGNMENTS FOR PIN 1 ORIENTATION IN TAPE**

\*All dimensions are nominal

Device	Package Type	Package Drawing	Pins	SPQ	Reel Diameter (mm)	Reel Width W1 (mm)	A0 (mm)	B0 (mm)	K0 (mm)	P1 (mm)	W (mm)	Pin1 Quadrant
TRSF3238EIDBR	SSOP	DB	28	2000	330.0	16.4	8.2	10.5	2.5	12.0	16.0	Q1
TRSF3238EIDWR	SOIC	DW	28	1000	330.0	32.4	11.35	18.67	3.1	16.0	32.0	Q1

## TAPE AND REEL BOX DIMENSIONS



\*All dimensions are nominal

Device	Package Type	Package Drawing	Pins	SPQ	Length (mm)	Width (mm)	Height (mm)
TRSF3238EIDBR	SSOP	DB	28	2000	356.0	356.0	35.0
TRSF3238EIDWR	SOIC	DW	28	1000	350.0	350.0	66.0

DW (R-PDSO-G28)

PLASTIC SMALL OUTLINE

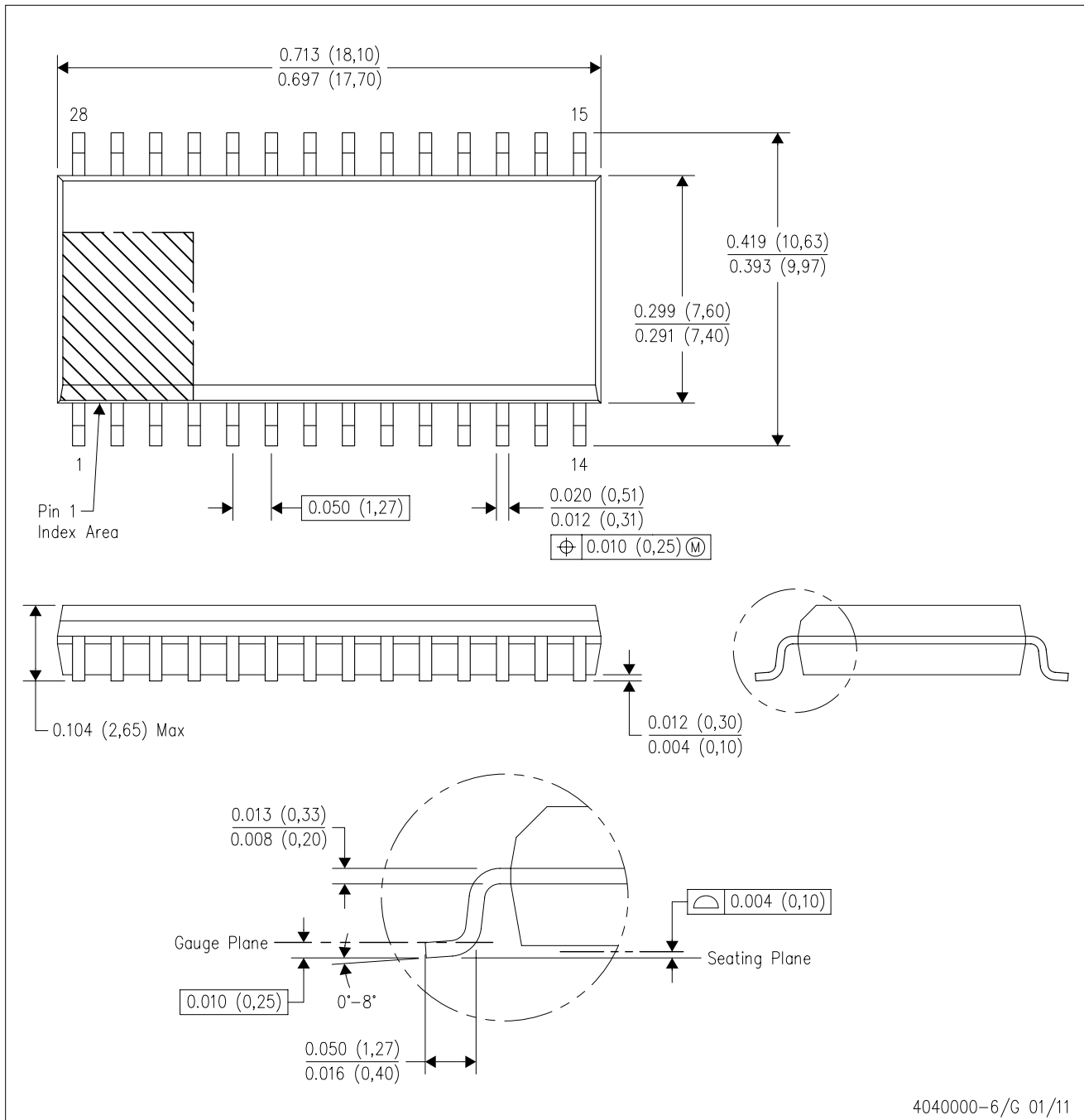

4040000-6/G 01/11

- NOTES:
- All linear dimensions are in inches (millimeters). Dimensioning and tolerancing per ASME Y14.5M-1994.
  - This drawing is subject to change without notice.
  - Body dimensions do not include mold flash or protrusion not to exceed 0.006 (0,15).
  - Falls within JEDEC MS-013 variation AE.

DW (R-PDSO-G28)

PLASTIC SMALL OUTLINE

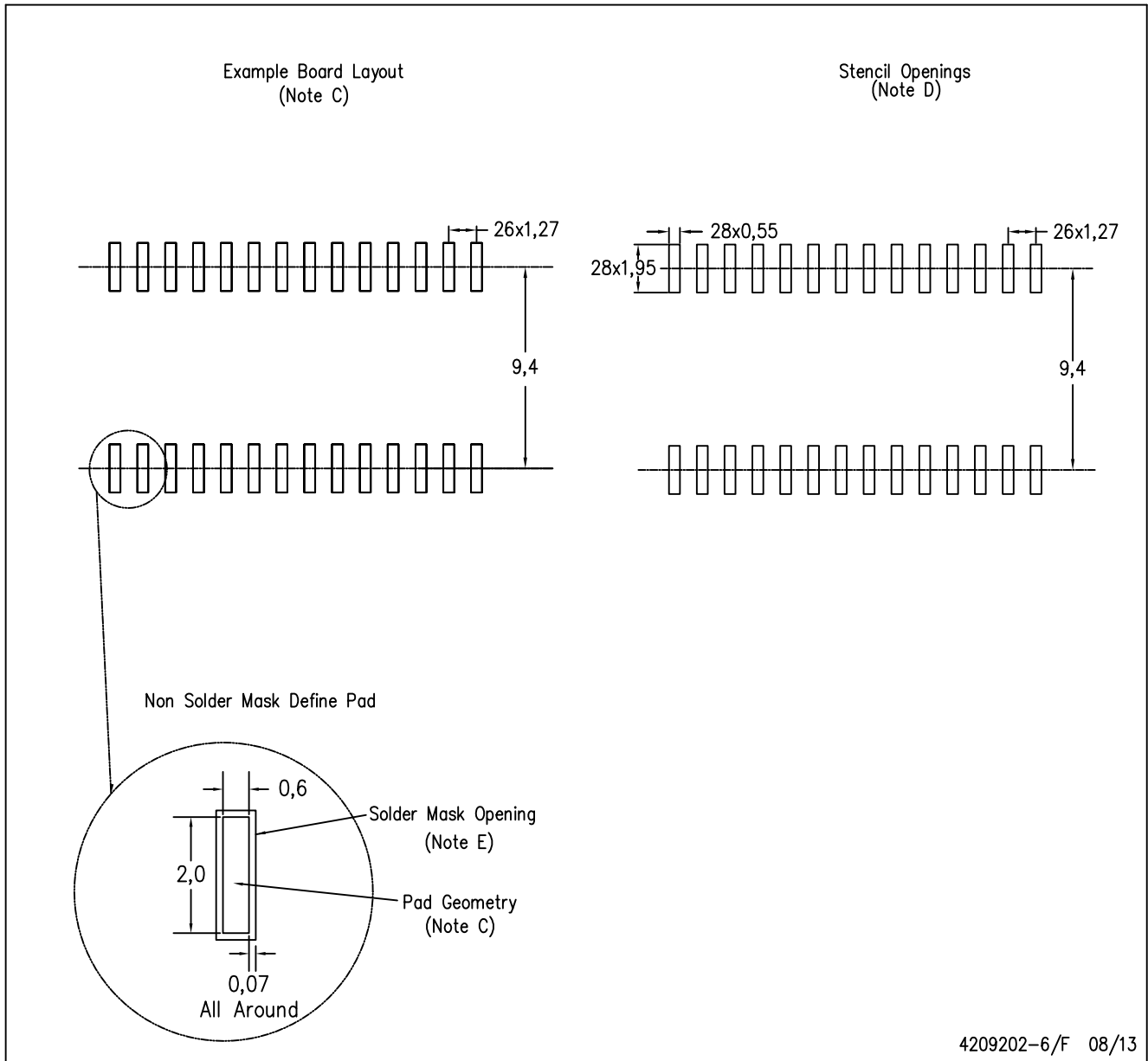

- NOTES:
- A. All linear dimensions are in millimeters.
  - B. This drawing is subject to change without notice.
  - C. Refer to IPC7351 for alternate board design.
  - D. Laser cutting apertures with trapezoidal walls and also rounding corners will offer better paste release. Customers should contact their board assembly site for stencil design recommendations. Refer to IPC-7525
  - E. Customers should contact their board fabrication site for solder mask tolerances between and around signal pads.

# DB0028A



# PACKAGE OUTLINE

## SSOP - 2 mm max height

SMALL OUTLINE PACKAGE

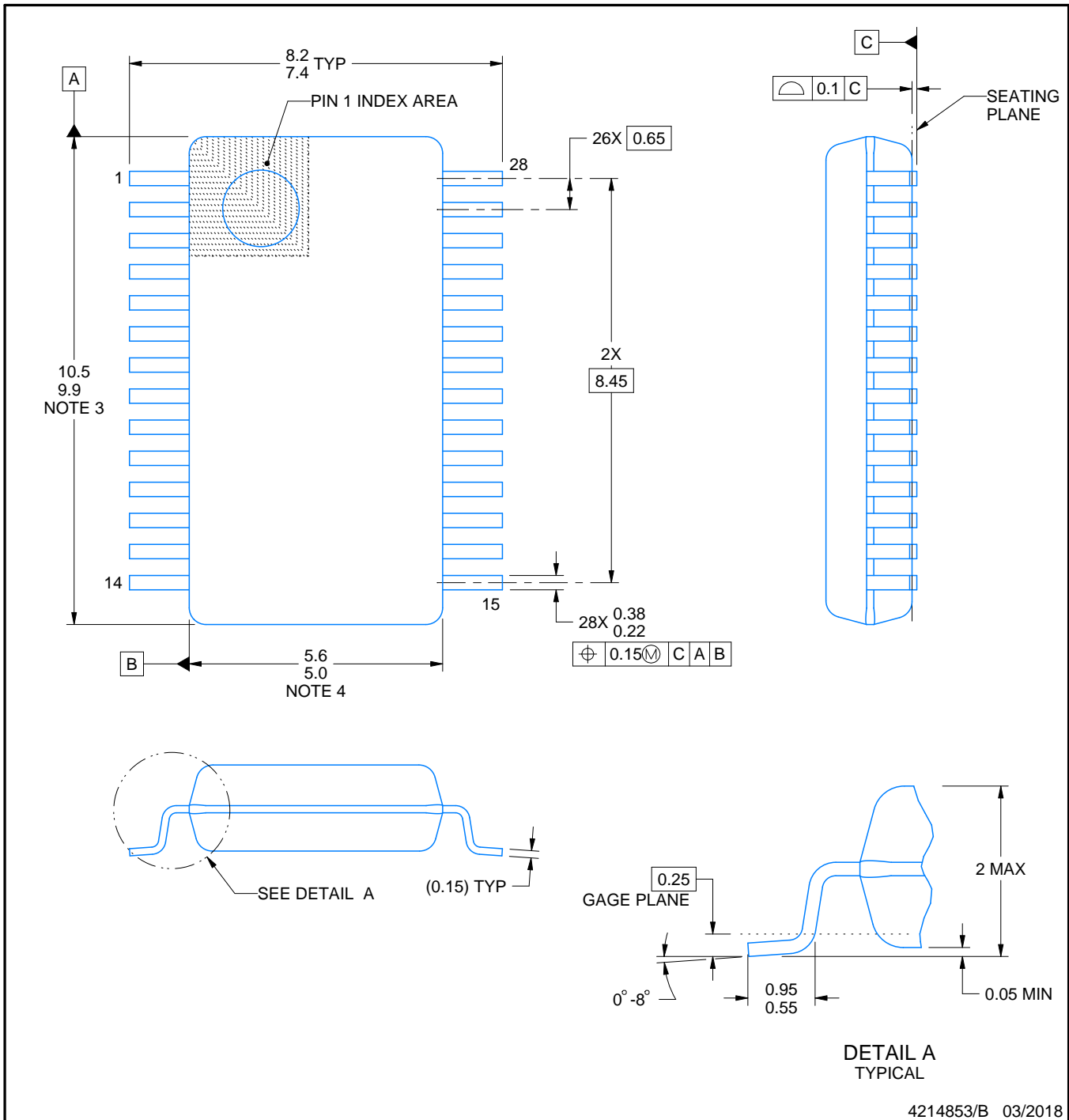

4214853/B 03/2018

### NOTES:

- All linear dimensions are in millimeters. Any dimensions in parenthesis are for reference only. Dimensioning and tolerancing per ASME Y14.5M.
- This drawing is subject to change without notice.
- This dimension does not include mold flash, protrusions, or gate burrs. Mold flash, protrusions, or gate burrs shall not exceed 0.15 mm per side.
- This dimension does not include interlead flash. Interlead flash shall not exceed 0.25 mm per side.
- Reference JEDEC registration MO-150.

# EXAMPLE BOARD LAYOUT

DB0028A

SSOP - 2 mm max height

SMALL OUTLINE PACKAGE

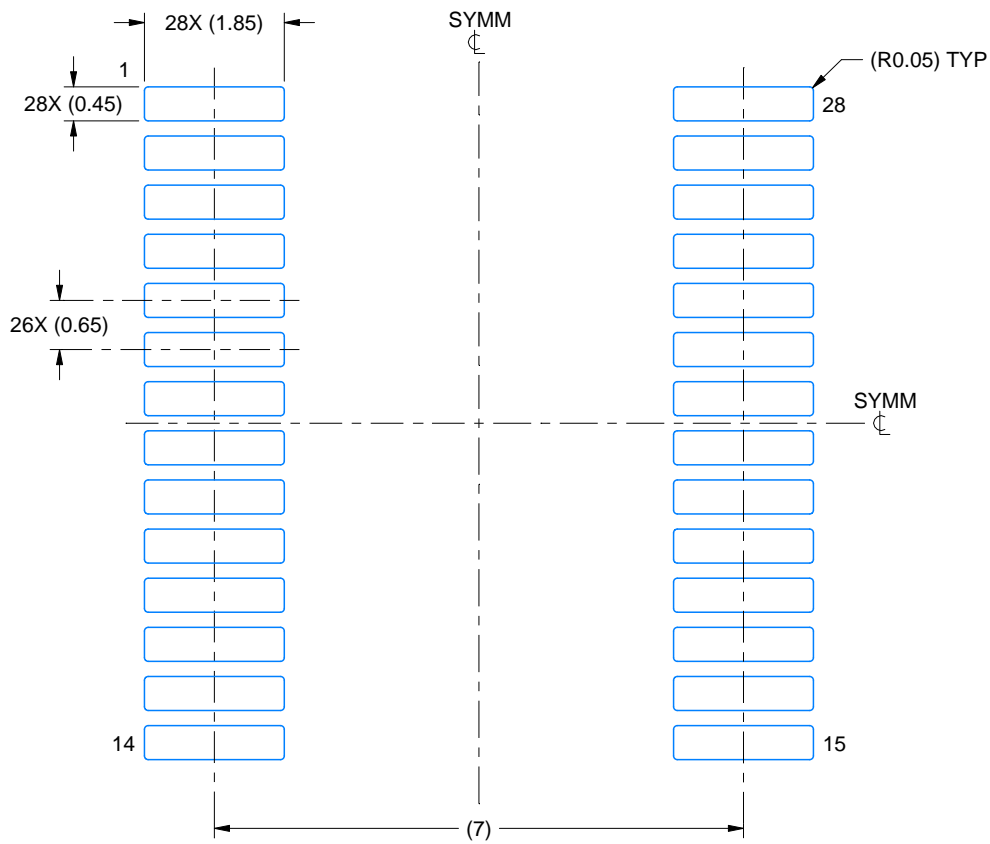

LAND PATTERN EXAMPLE  
EXPOSED METAL SHOWN  
SCALE: 10X

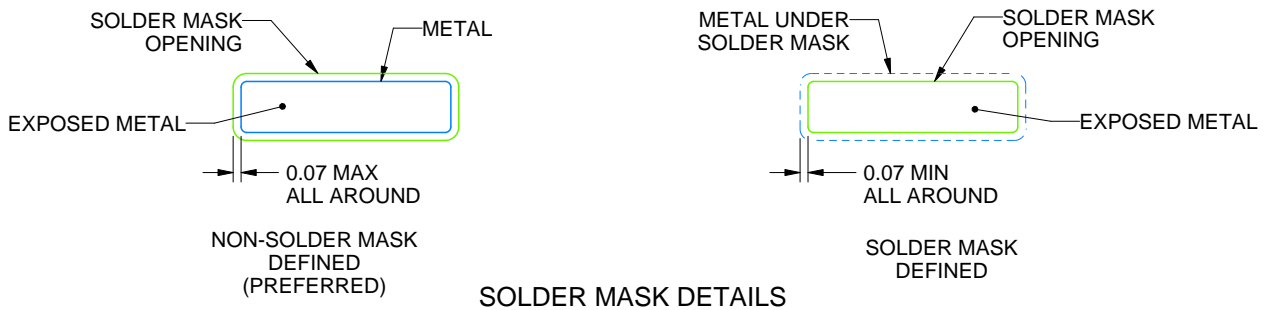

4214853/B 03/2018

NOTES: (continued)

- 6. Publication IPC-7351 may have alternate designs.
- 7. Solder mask tolerances between and around signal pads can vary based on board fabrication site.

# EXAMPLE STENCIL DESIGN

DB0028A

SSOP - 2 mm max height

SMALL OUTLINE PACKAGE

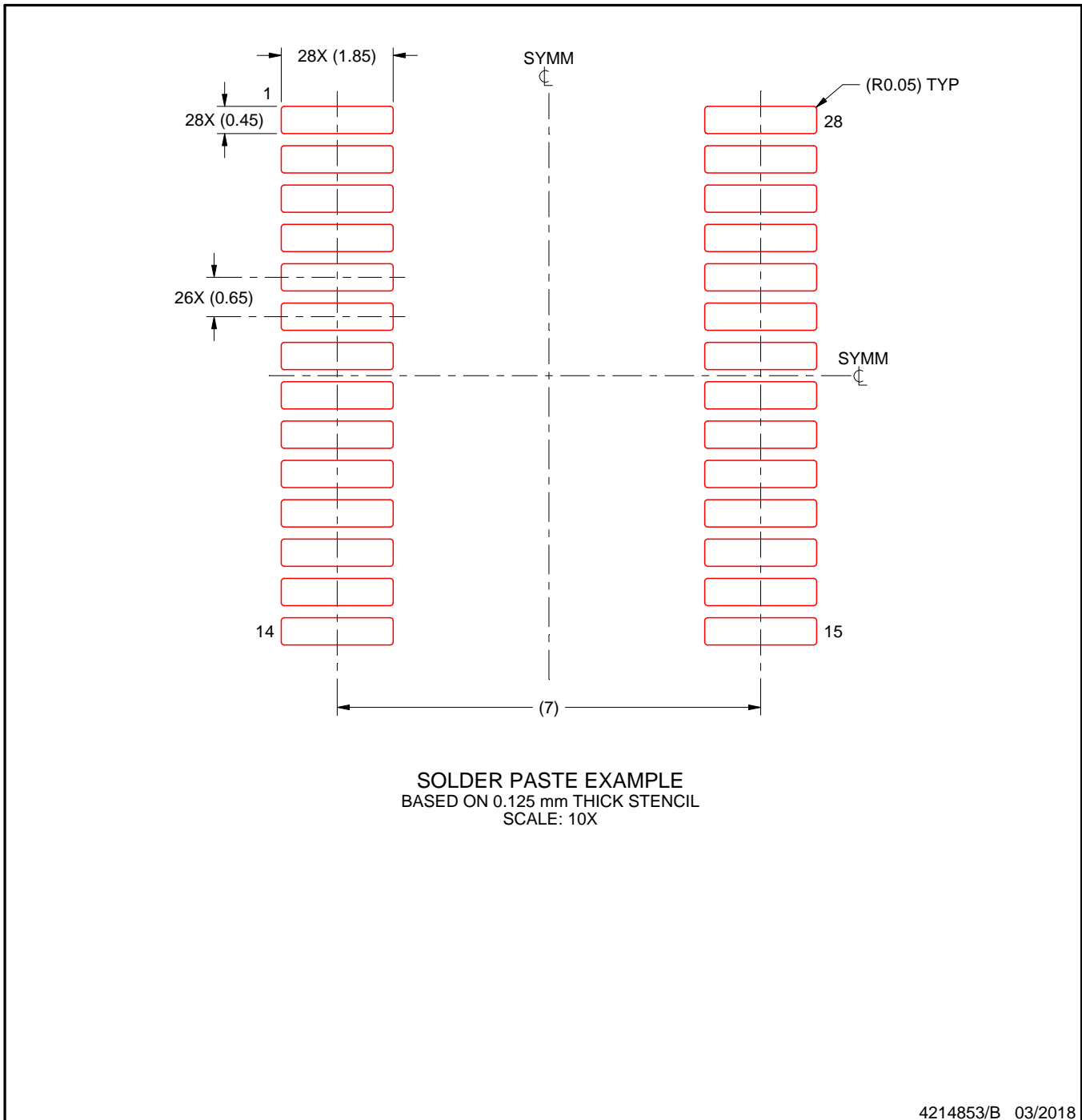

NOTES: (continued)

8. Laser cutting apertures with trapezoidal walls and rounded corners may offer better paste release. IPC-7525 may have alternate design recommendations.
9. Board assembly site may have different recommendations for stencil design.

## IMPORTANT NOTICE AND DISCLAIMER

TI PROVIDES TECHNICAL AND RELIABILITY DATA (INCLUDING DATA SHEETS), DESIGN RESOURCES (INCLUDING REFERENCE DESIGNS), APPLICATION OR OTHER DESIGN ADVICE, WEB TOOLS, SAFETY INFORMATION, AND OTHER RESOURCES "AS IS" AND WITH ALL FAULTS, AND DISCLAIMS ALL WARRANTIES, EXPRESS AND IMPLIED, INCLUDING WITHOUT LIMITATION ANY IMPLIED WARRANTIES OF MERCHANTABILITY, FITNESS FOR A PARTICULAR PURPOSE OR NON-INFRINGEMENT OF THIRD PARTY INTELLECTUAL PROPERTY RIGHTS.

These resources are intended for skilled developers designing with TI products. You are solely responsible for (1) selecting the appropriate TI products for your application, (2) designing, validating and testing your application, and (3) ensuring your application meets applicable standards, and any other safety, security, regulatory or other requirements.

These resources are subject to change without notice. TI grants you permission to use these resources only for development of an application that uses the TI products described in the resource. Other reproduction and display of these resources is prohibited. No license is granted to any other TI intellectual property right or to any third party intellectual property right. TI disclaims responsibility for, and you will fully indemnify TI and its representatives against, any claims, damages, costs, losses, and liabilities arising out of your use of these resources.

TI's products are provided subject to [TI's Terms of Sale](#) or other applicable terms available either on [ti.com](https://www.ti.com) or provided in conjunction with such TI products. TI's provision of these resources does not expand or otherwise alter TI's applicable warranties or warranty disclaimers for TI products.

TI objects to and rejects any additional or different terms you may have proposed.

Mailing Address: Texas Instruments, Post Office Box 655303, Dallas, Texas 75265  
Copyright © 2024, Texas Instruments Incorporated

## Looking for pricing, stock, or lifecycle information?

Click below to explore more details on WIN SOURCE:

 [View TRSF3238EIDBR on WIN SOURCE](#)

 [Texas Instruments](#) Information

## Optimize Your Supply Chain with WIN SOURCE Solutions

-  Global Sourcing Solution
-  Obsolete Management
-  Cost Control Management
-  Shortage Management
-  Alternative Solution
-  Excess Inventory Management