



**THE DATASHEET OF
NB4N855SMR4G**



3.3 V, 1.5 Gb/s Dual AnyLevel™ to LVDS Receiver/Driver/Buffer/Translator NB4N855S

Description

NB4N855S is a clock or data Receiver/Driver/Buffer/Translator capable of translating AnyLevel input signal (LVPECL, CML, HSTL, LVDS, or LVTTL/LVCMOS) to LVDS. Depending on the distance, noise immunity of the system design, and transmission line media, this device will receive, drive or translate data or clock signals up to 1.5 Gb/s or 1.0 GHz, respectively. This device is pin-for-pin plug in compatible to the SY55855V in a 3.3 V applications.

The NB4N855S has a wide input common mode range of $GND + 50\text{ mV}$ to $V_{CC} - 50\text{ mV}$. This feature is ideal for translating differential or single-ended data or clock signals to 350 mV typical LVDS output levels.

The device is offered in a small 10 lead MSOP package. NB4N855S is targeted for data, wireless and telecom applications as well as high speed logic interface where jitter and package size are main requirements.

Application notes, models, and support documentation are available at www.onsemi.com.

Features

- Guaranteed Input Clock Frequency up to 1.0 GHz
- Guaranteed Input Data Rate up to 1.5 Gb/s
- 490 ps Maximum Propagation Delay
- 1.0 ps Maximum RMS Jitter
- 180 ps Maximum Rise/Fall Times
- Single Power Supply; $V_{CC} = 3.3\text{ V} \pm 10\%$
- Temperature Compensated TIA/EIA-644 Compliant LVDS Outputs
- $GND + 50\text{ mV}$ to $V_{CC} - 50\text{ mV}$ V_{CMR} Range
- This is a Pb-Free Device

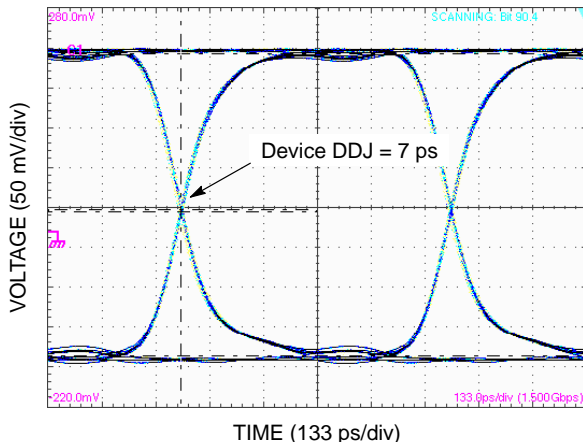
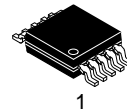
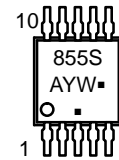

Figure 1. Typical Output Waveform at 1.5 Gb/s with K28.5 ($V_{INPP} = 100\text{ mV}$, Input Signal DDJ = 24 ps)



Micro-10
M SUFFIX
CASE 846B

MARKING DIAGRAM*



A = Assembly Location
Y = Year
W = Work Week
▪ = Pb-Free Package

(Note: Microdot may be in either location)

*For additional marking information, refer to Application Note AND8002/D.

FUNCTIONAL BLOCK DIAGRAM

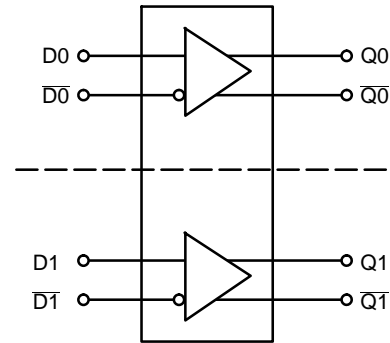

ORDERING INFORMATION

See detailed ordering and shipping information in the package dimensions section on page 8 of this data sheet.

NB4N855S

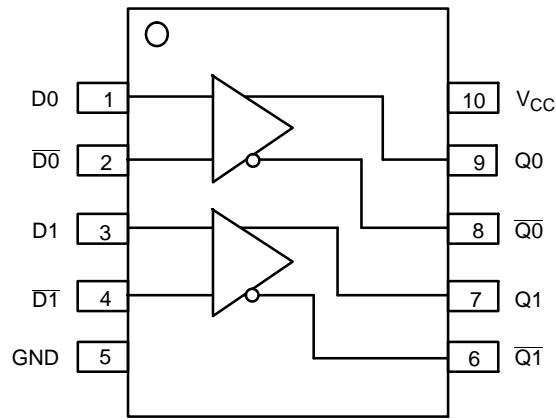

**Figure 2. Pin Configuration and Block Diagram
(Top View)**

Table 1. PIN DESCRIPTION

| Pin | Name | I/O | Description |
|-----|-----------------|-----------------------------------|---|
| 1 | D0 | LVPECL, CML, LVCMOS, LVTTTL, LVDS | Noninverted Differential Clock/Data D0 Input. |
| 2 | $\overline{D0}$ | LVPECL, CML, LVCMOS, LVTTTL, LVDS | Inverted Differential Clock/Data $\overline{D0}$ Input. |
| 3 | D1 | LVPEL, CML, LVDS LVCMOS, LVTTTL | Noninverted Differential Clock/Data D1 Input. |
| 4 | $\overline{D1}$ | LVPECL, CML, LVDS LVCMOS LVTTTL | Inverted Differential Clock/Data $\overline{D1}$ Input. |
| 5 | GND | - | Ground. 0 V. |
| 6 | $\overline{Q1}$ | LVDS Output | Inverted $\overline{Q1}$ output. Typically loaded with 100 Ω receiver termination resistor across differential pair. |
| 7 | Q1 | LVDS Output | Noninverted Q1 output. Typically loaded with 100 Ω receiver termination resistor across differential pair. |
| 8 | $\overline{Q0}$ | LVDS Output | Inverted $\overline{Q0}$ output. Typically loaded with 100 Ω receiver termination resistor across differential pair. |
| 9 | Q0 | LVDS Output | Noninverted Q0 output. Typically loaded with 100 Ω receiver termination resistor across differential pair. |
| 10 | V _{CC} | - | Positive Supply Voltage. |

NB4N855S

Table 2. ATTRIBUTES

| Characteristics | | Value | |
|--|---|-----------------------------|-------------|
| Moisture Sensitivity (Note 1) | | Pb Pkg | Pb-Free Pkg |
| Micro-10 | | Level 1 | Level 1 |
| Flammability Rating | Oxygen Index: 28 to 34 | UL 94 V-0 @ 0.125 in | |
| ESD Protection | Human Body Model Machine Model Charged Device Model | > 2 kV > 200 V > 1 kV | |
| Transistor Count | | 281 | |
| Meets or exceeds JEDEC Spec EIA/JESD78 IC Latchup Test | | | |

1. For additional information, see Application Note AND8003/D.

Table 3. MAXIMUM RATINGS

| Symbol | Parameter | Condition 1 | Condition 2 | Rating | Unit |
|------------------|---|---|----------------------------------|-------------|--------------|
| V _{CC} | Positive Power Supply | GND = 0 V | | 3.8 | V |
| V _I | Positive Input | GND = 0 V | V _I = V _{CC} | 3.8 | V |
| I _{OSC} | Output Short Circuit Current Line-to-Line (Q to \bar{Q}) Line-to-End (Q or \bar{Q} to GND) | Q to \bar{Q} Q or \bar{Q} to GND | Continuous Continuous | 12 24 | mA |
| T _A | Operating Temperature Range | Micro-10 | | -40 to +85 | °C |
| T _{stg} | Storage Temperature Range | | | -65 to +150 | °C |
| θ _{JA} | Thermal Resistance (Junction-to-Ambient) (Note 2) | 0 lfpm 500 lfpm | Micro-10 Micro-10 | 177 132 | °C/W °C/W |
| θ _{JC} | Thermal Resistance (Junction-to-Case) | 1S2P (Note 4) | Micro-10 | 40 | °C/W |
| T _{sol} | Wave Solder | Pb Pb-Free | <3 Sec @ 248°C <3 Sec @ 260°C | 265 265 | °C |

Stresses exceeding those listed in the Maximum Ratings table may damage the device. If any of these limits are exceeded, device functionality should not be assumed, damage may occur and reliability may be affected.

2. JEDEC standard multilayer board – 1S2P (1 signal, 2 power).

NB4N855S

Table 4. DC CHARACTERISTICS, CLOCK INPUTS, LVDS OUTPUTS $V_{CC} = 3.0\text{ V to }3.6\text{ V}$, $GND = 0\text{ V}$, $T_A = -40^\circ\text{C to }+85^\circ\text{C}$

| Symbol | Characteristic | Min | Typ | Max | Unit |
|----------|-------------------------------|-----|-----|-----|------|
| I_{CC} | Power Supply Current (Note 3) | | 40 | 53 | mA |

DIFFERENTIAL INPUTS DRIVEN SINGLE-ENDED (Figures 10 and 12)

| | | | | | |
|----------|--|----------------|--|----------------|----|
| V_{th} | Input Threshold Reference Voltage Range (Note 4) | GND +100 | | $V_{CC} - 100$ | mV |
| V_{IH} | Single-ended Input HIGH Voltage | $V_{th} + 100$ | | V_{CC} | mV |
| V_{IL} | Single-ended Input LOW Voltage | GND | | $V_{th} - 100$ | mV |

DIFFERENTIAL INPUTS DRIVEN DIFFERENTIALLY (Figures 11 and 13)

| | | | | | |
|-----------|--|----------|--|----------------|----|
| V_{IHD} | Differential Input HIGH Voltage | 100 | | V_{CC} | mV |
| V_{ILD} | Differential Input LOW Voltage | GND | | $V_{CC} - 100$ | mV |
| V_{CMR} | Input Common Mode Range (Differential Configuration) | GND + 50 | | $V_{CC} - 50$ | mV |
| V_{ID} | Differential Input Voltage ($V_{IHD} - V_{ILD}$) | 100 | | V_{CC} | mV |

LVDS OUTPUTS (Note 5)

| | | | | | |
|-----------------|--|------|------|------|----|
| V_{OD} | Differential Output Voltage | 250 | | 450 | mV |
| ΔV_{OD} | Change in Magnitude of V_{OD} for Complementary Output States (Note 6) | 0 | 1.0 | 25 | mV |
| V_{OS} | Offset Voltage (Figure 9) | 1125 | | 1375 | mV |
| ΔV_{OS} | Change in Magnitude of V_{OS} for Complementary Output States (Note 6) | 0 | 1.0 | 25 | mV |
| V_{OH} | Output HIGH Voltage (Note 7) | | 1425 | 1600 | mV |
| V_{OL} | Output LOW Voltage (Note 8) | 900 | 1075 | | mV |

NOTE: Device will meet the specifications after thermal equilibrium has been established when mounted in a test socket or printed circuit board with maintained transverse airflow greater than 500 lfpm.

3. Dx/\overline{Dx} at the DC level within V_{CMR} and output pins loaded with $R_L = 100\ \Omega$ across differential.
4. V_{th} is applied to the complementary input when operating in single-ended mode.
5. LVDS outputs require $100\ \Omega$ receiver termination resistor between differential pair. See Figure 8.
6. Parameter guaranteed by design verification not tested in production.
7. $V_{OHmax} = V_{OSmax} + \frac{1}{2} V_{ODmax}$.
8. $V_{OLmax} = V_{OSmin} - \frac{1}{2} V_{ODmax}$.

NB4N855S

Table 5. AC CHARACTERISTICS $V_{CC} = 3.0\text{ V to }3.6\text{ V}$, $GND = 0\text{ V}$; (Note 9)

| Symbol | Characteristic | -40°C | | | 25°C | | | 85°C | | | Unit |
|--------------------------|---|------------|----------------------------------|--------------------------------|------------|----------------------------------|--------------------------------|------------|----------------------------------|--------------------------------|------|
| | | Min | Typ | Max | Min | Typ | Max | Min | Typ | Max | |
| V_{OUTPP} | Output Voltage Amplitude (@ $V_{INPPMIN}$) $f_{in} \leq 1.0\text{ GHz}$ (Figure 3) $f_{in} = 1.5\text{ GHz}$ | 230 200 | 350 300 | | 230 200 | 350 300 | | 230 200 | 350 300 | | mV |
| f_{DATA} | Maximum Operating Data Rate | 1.5 | 2.5 | | 1.5 | 2.5 | | 1.5 | 2.5 | | Gb/s |
| t_{PLH} , t_{PHL} | Differential Input to Differential Output Propagation Delay | 330 | 410 | 490 | 330 | 410 | 490 | 330 | 410 | 490 | ps |
| t_{SKEW} | Duty Cycle Skew (Note 10) Within -Device Skew (Note 11) Device to Device Skew (Note 12) | | 8 10 20 | 45 35 100 | | 8 10 20 | 45 35 100 | | 8 10 20 | 45 35 100 | ps |
| t_{JITTER} | RMS Random Clock Jitter (Note 13) $f_{in} = 1.0\text{ GHz}$ $f_{in} = 1.5\text{ GHz}$ Deterministic Jitter (Note 14) $f_{DATA} = 622\text{ Mb/s}$ $f_{DATA} = 1.5\text{ Gb/s}$ $f_{DATA} = 2.488\text{ Gb/s}$ Crosstalk Induced Jitter (Note 15) | | 0.5 0.5 6 7 10 20 | 1 1 15 20 25 40 | | 0.5 0.5 6 7 10 20 | 1 1 15 20 25 40 | | 0.5 0.5 6 7 10 20 | 1 1 15 20 25 40 | ps |
| V_{INPP} | Input Voltage Swing/Sensitivity (Differential Configuration) (Note 16) | 100 | | $V_{CC}-GND$ | 100 | | $V_{CC}-GND$ | 100 | | $V_{CC}-GND$ | mV |
| t_r t_f | Output Rise/Fall Times @ 250 MHz (20% – 80%) Q, \bar{Q} | 50 | 110 | 180 | 50 | 110 | 180 | 50 | 110 | 180 | ps |

NOTE: Device will meet the specifications after thermal equilibrium has been established when mounted in a test socket or printed circuit board with maintained transverse airflow greater than 500 lpm.

9. Measured by forcing $V_{INPPMIN}$ with 50% duty cycle clock source and $V_{CC} - 1400\text{ mV}$ offset. All loading with an external $R_L = 100\ \Omega$ across "D" and "D" of the receiver. Input edge rates 150 ps (20%–80%).

10. See Figure 7 differential measurement of $t_{skew} = |t_{PLH} - t_{PHL}|$ for a nominal 50% differential clock input waveform @ 250 MHz.

11. The worst case condition between $Q0/Q0$ and $Q1/Q1$ from either $D0/D0$ or $D1/D1$, when both outputs have the same transition.

12. Skew is measured between outputs under identical transition @ 250 MHz.

13. RMS jitter with 50% Duty Cycle clock signal.

14. Deterministic jitter with input NRZ data at PRBS $2^{23}-1$ and K28.5.

15. Crosstalk Induced Jitter is the additive Deterministic jitter to channel one with channel two active both running at 622 Gb/s PRBS $2^{23}-1$ as an asynchronous signals.

16. Input voltage swing is a single-ended measurement operating in differential mode.

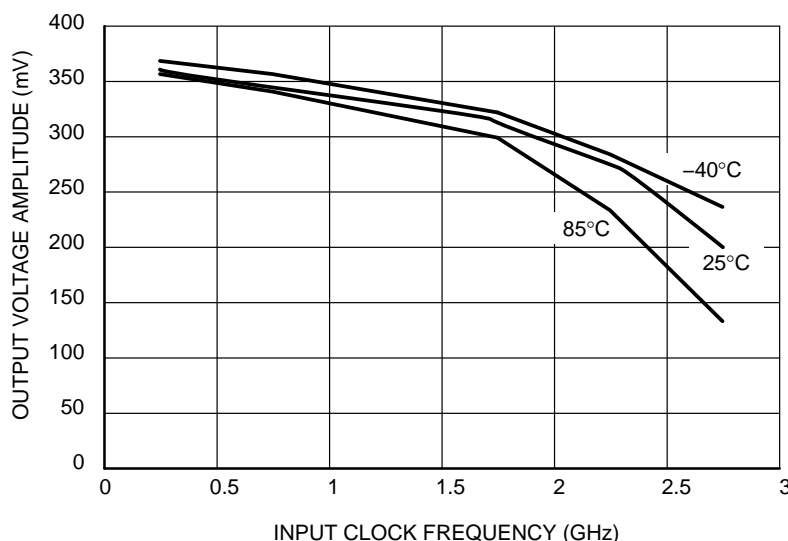
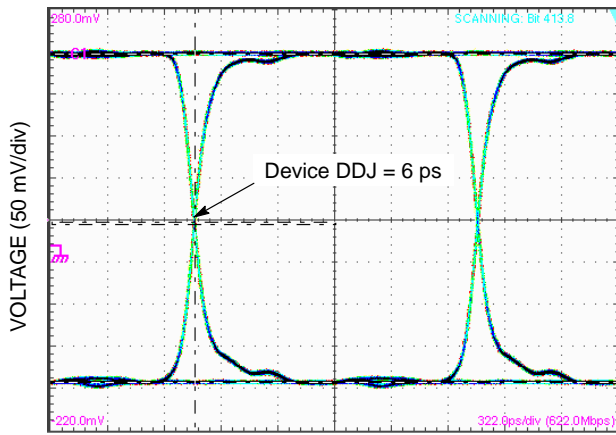
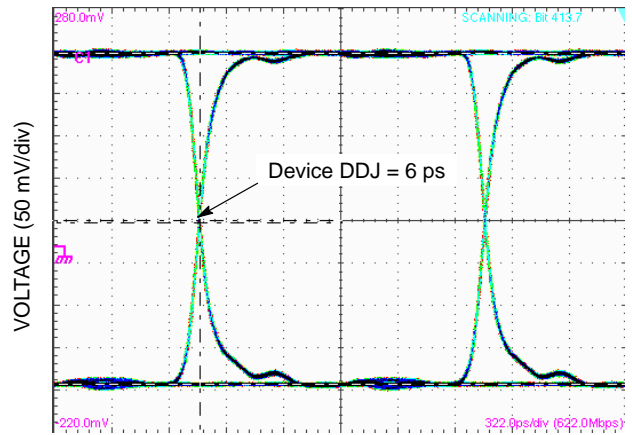

Figure 3. Output Voltage Amplitude (V_{OUTPP}) versus Input Clock Frequency (f_{in}) and Temperature (@ $V_{CC} = 3.3\text{ V}$)

NB4N855S



TIME (322 ps/div)



TIME (322 ps/div)

Figure 4. Typical Output Waveform at 1.5 Gb/s with $2^{23}-1$
 ($V_{INPP} = 100$ mV (left) & $V_{INPP} = 400$ mV (right), Input Signal DDJ = 24 ps)

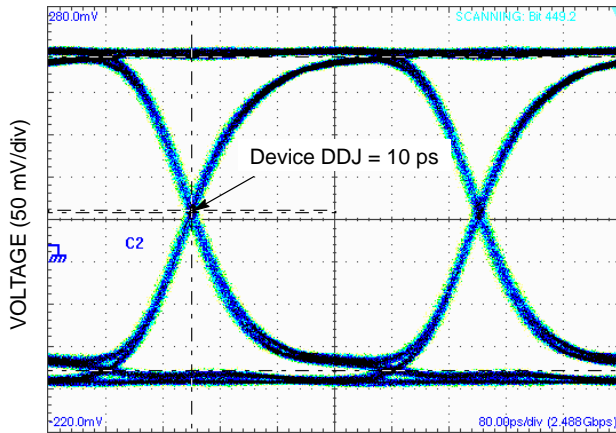

TIME (80 ps/div)

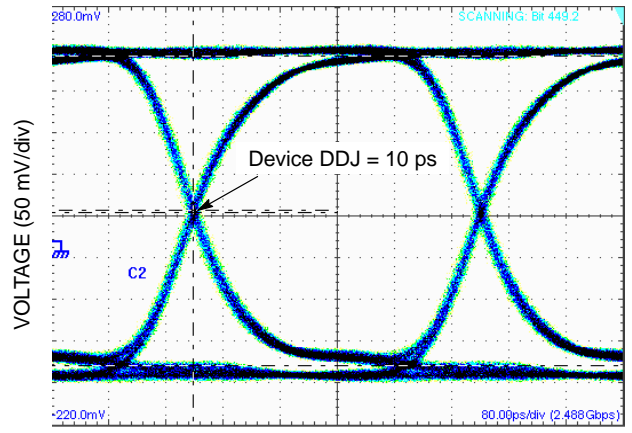

TIME (80 ps/div)

Figure 5. Typical Output Waveform at 2.488 Gb/s with $2^{23}-1$
 ($V_{INPP} = 100$ mV (left) & $V_{INPP} = 400$ mV (right), Input Signal DDJ = 30 ps)

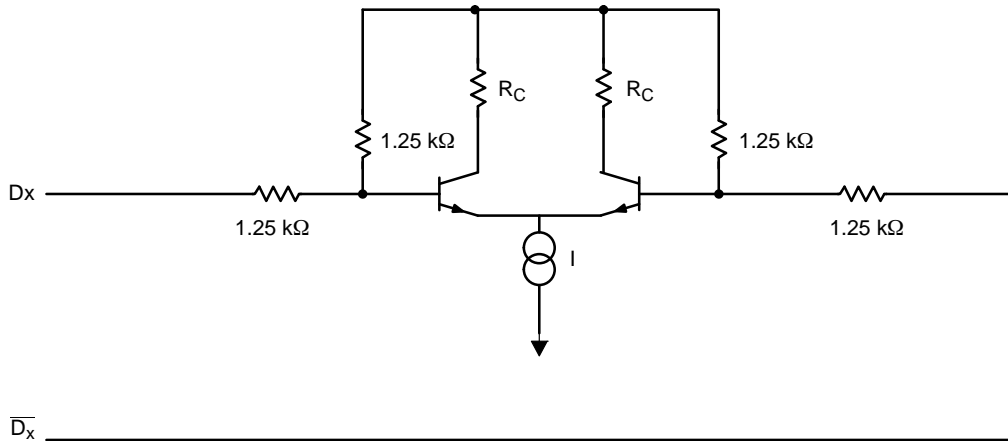

Figure 6. Input Structure

NB4N855S

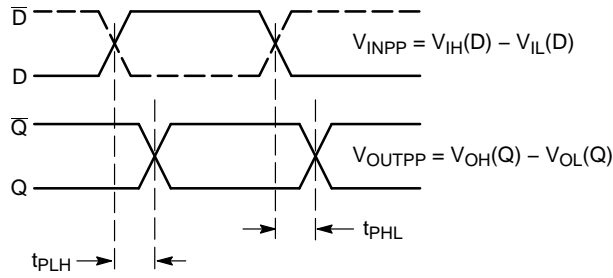

Figure 7. AC Reference Measurement

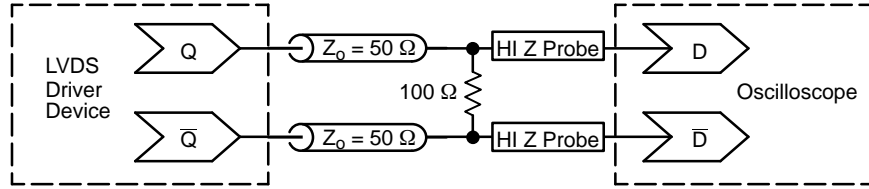

Figure 8. Typical LVDS Termination for Output Driver and Device Evaluation

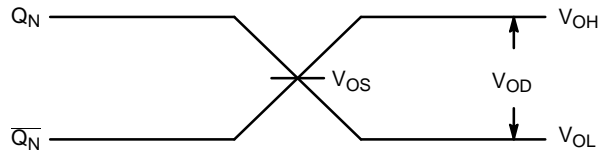

Figure 9. LVDS Output

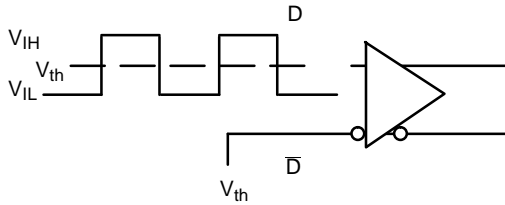

Figure 10. Differential Input Driven Single-Ended

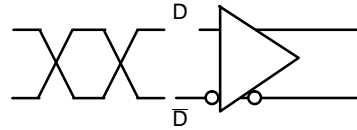

Figure 11. Differential Inputs Driven Differentially

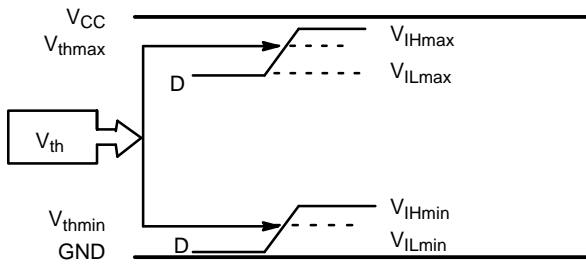

Figure 12. V_{th} Diagram

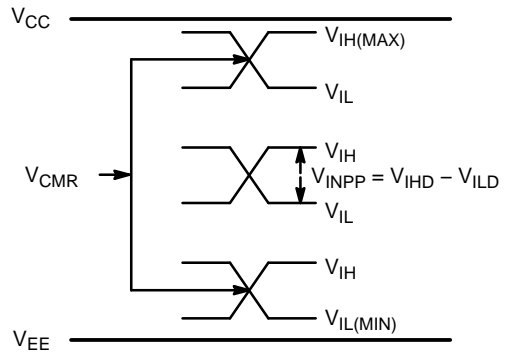

Figure 13. V_{CMR} Diagram

NB4N855S

ORDERING INFORMATION

| Device | Package | Shipping† |
|--------------|-----------------------|--------------------|
| NB4N855SMR4G | Micro-10 (Pb-Free) | 1000 / Tape & Reel |

†For information on tape and reel specifications, including part orientation and tape sizes, please refer to our Tape and Reel Packaging Specifications Brochure, BRD8011/D

AnyLevel is trademark of Semiconductor Components Industries, LLC dba "onsemi" or its affiliates and/or subsidiaries in the United States and/or other countries.

MECHANICAL CASE OUTLINE PACKAGE DIMENSIONS

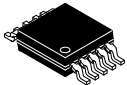

SCALE 2:1

Micro10
CASE 846B-03
ISSUE D

DATE 07 DEC 2004

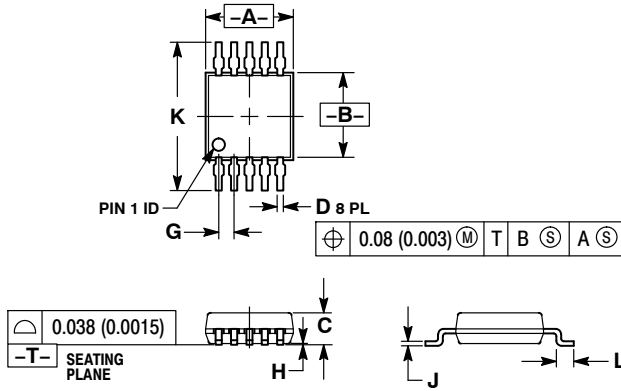

NOTES:

1. DIMENSIONING AND TOLERANCING PER ANSI Y14.5M, 1982.
2. CONTROLLING DIMENSION: MILLIMETER.
3. DIMENSION "A" DOES NOT INCLUDE MOLD FLASH, PROTRUSIONS OR GATE BURRS. MOLD FLASH, PROTRUSIONS OR GATE BURRS SHALL NOT EXCEED 0.15 (0.006) PER SIDE.
4. DIMENSION "B" DOES NOT INCLUDE INTERLEAD FLASH OR PROTRUSION. INTERLEAD FLASH OR PROTRUSION SHALL NOT EXCEED 0.25 (0.010) PER SIDE.
5. 846B-01 OBSOLETE. NEW STANDARD 846B-02

| DIM | MILLIMETERS | | INCHES | |
|-----|-------------|------|-----------|-------|
| | MIN | MAX | MIN | MAX |
| A | 2.90 | 3.10 | 0.114 | 0.122 |
| B | 2.90 | 3.10 | 0.114 | 0.122 |
| C | 0.95 | 1.10 | 0.037 | 0.043 |
| D | 0.20 | 0.30 | 0.008 | 0.012 |
| G | 0.50 BSC | | 0.020 BSC | |
| H | 0.05 | 0.15 | 0.002 | 0.006 |
| J | 0.10 | 0.21 | 0.004 | 0.008 |
| K | 4.75 | 5.05 | 0.187 | 0.199 |
| L | 0.40 | 0.70 | 0.016 | 0.028 |

SOLDERING FOOTPRINT

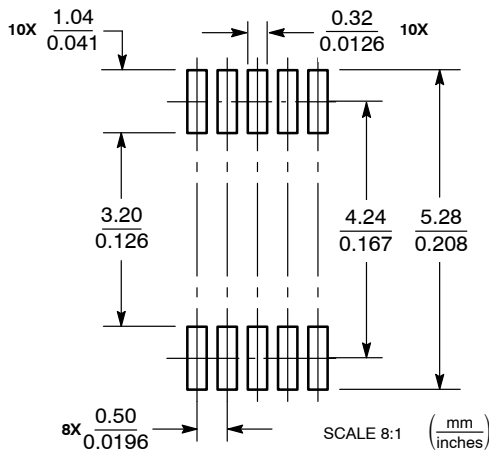

Micro10

GENERIC MARKING DIAGRAM*



- xxxx = Device Code
- A = Assembly Location
- Y = Year
- W = Work Week
- = Pb-Free Package

*This information is generic. Please refer to device data sheet for actual part marking. Pb-Free indicator, "G" or microdot "▪", may or may not be present. Some products may not follow the Generic Marking.

| | | |
|-------------------------|--------------------|--|
| DOCUMENT NUMBER: | 98AON03799D | Electronic versions are uncontrolled except when accessed directly from the Document Repository. Printed versions are uncontrolled except when stamped "CONTROLLED COPY" in red. |
| DESCRIPTION: | Micro10 | PAGE 1 OF 1 |

onsemi and ONSEMI are trademarks of Semiconductor Components Industries, LLC dba onsemi or its subsidiaries in the United States and/or other countries. onsemi reserves the right to make changes without further notice to any products herein. onsemi makes no warranty, representation or guarantee regarding the suitability of its products for any particular purpose, nor does onsemi assume any liability arising out of the application or use of any product or circuit, and specifically disclaims any and all liability, including without limitation special, consequential or incidental damages. onsemi does not convey any license under its patent rights nor the rights of others.

onsemi, **Onsemi**, and other names, marks, and brands are registered and/or common law trademarks of Semiconductor Components Industries, LLC dba "**onsemi**" or its affiliates and/or subsidiaries in the United States and/or other countries. **onsemi** owns the rights to a number of patents, trademarks, copyrights, trade secrets, and other intellectual property. A listing of **onsemi**'s product/patent coverage may be accessed at www.onsemi.com/site/pdf/Patent-Marking.pdf. **onsemi** reserves the right to make changes at any time to any products or information herein, without notice. The information herein is provided "as-is" and **onsemi** makes no warranty, representation or guarantee regarding the accuracy of the information, product features, availability, functionality, or suitability of its products for any particular purpose, nor does **onsemi** assume any liability arising out of the application or use of any product or circuit, and specifically disclaims any and all liability, including without limitation special, consequential or incidental damages. Buyer is responsible for its products and applications using **onsemi** products, including compliance with all laws, regulations and safety requirements or standards, regardless of any support or applications information provided by **onsemi**. "Typical" parameters which may be provided in **onsemi** data sheets and/or specifications can and do vary in different applications and actual performance may vary over time. All operating parameters, including "Typicals" must be validated for each customer application by customer's technical experts. **onsemi** does not convey any license under any of its intellectual property rights nor the rights of others. **onsemi** products are not designed, intended, or authorized for use as a critical component in life support systems or any FDA Class 3 medical devices or medical devices with a same or similar classification in a foreign jurisdiction or any devices intended for implantation in the human body. Should Buyer purchase or use **onsemi** products for any such unintended or unauthorized application, Buyer shall indemnify and hold **onsemi** and its officers, employees, subsidiaries, affiliates, and distributors harmless against all claims, costs, damages, and expenses, and reasonable attorney fees arising out of, directly or indirectly, any claim of personal injury or death associated with such unintended or unauthorized use, even if such claim alleges that **onsemi** was negligent regarding the design or manufacture of the part. **onsemi** is an Equal Opportunity/Affirmative Action Employer. This literature is subject to all applicable copyright laws and is not for resale in any manner.

ADDITIONAL INFORMATION

TECHNICAL PUBLICATIONS:

Technical Library: www.onsemi.com/design/resources/technical-documentation
onsemi Website: www.onsemi.com

ONLINE SUPPORT: www.onsemi.com/support

For additional information, please contact your local Sales Representative at www.onsemi.com/support/sales

Looking for pricing, stock, or lifecycle information?

Click below to explore more details on WIN SOURCE:

 [View NB4N855SMR4G on WIN SOURCE](#)

 [ON Semiconductor](#) Information

Optimize Your Supply Chain with WIN SOURCE Solutions

-  Global Sourcing Solution
-  Obsolete Management
-  Cost Control Management
-  Shortage Management
-  Alternative Solution
-  Excess Inventory Management