



# THE DATASHEET OF DM10



# NDI & DM SERIES SPST STANDARD DIP SWITCHES

## FEATURES

High reliability.  
Self-cleaning contacts.  
Multi- positions.  
Process compatible with tape seal.  
Dual in-line .100" x .300" term. spacing.

SPECIFICATIONS SUBJECT TO CHANGE WITHOUT NOTICE.

### GENERAL SPECIFICATIONS

#### ELECTRICALS

Electrical life	2000 cycles min. per switch @ 24 VDC, 25 mA
Contact rating, non-switching	100 mA at 50 VDC
Contact rating, switching	25 mA at 24 VDC
Contact resistance at current 100 mA	50 milliohms max. initial - 100 milliohms max. after life test
Insulation resistance at 500 VDC	100 Megohms minimum
Dielectric strength	500 VAC for 1 minute
Capacitance	5 pf. max. between adjacent terminals

#### MECHANICALS, THERMALS

Mechanical life	2000 cycles min. per switch
Operating force	1000 grams max.
Vibration	10-55 Hz. per MIL-STD-202F METHOD 201A
Shock	50 G (peak value) for 11 msec. per MIL-STD-202F, METHOD 213B
Operating temperature range	-20°C to 85°C

#### SOLDERING & CLEANING RECOMMENDATIONS\*

Hand soldering	350°C max. for 2 seconds max. (30 watt iron max.)
Wave soldering	260°C max. for 5 seconds max.
Cleaning (with tape seal)	Spray wash from top side only.

\* Note: keep switches in "OFF" position during soldering and cleaning for best results

### MATERIALS

Base & Cover	NDI: UL94V-O, glass fiber filled PBT, black DM: UL94V-O, glass fiber filled PPS, black
Actuators	UL94V-O, Nylon, white
Contacts	Gold over nickel plated copper alloy
Terminals	Gold plated brass.
Term. Sealing	Molded-in
Tape seal	Kapton

### PACKAGING

DIP switches are shipped in standard IC tubes with all actuators in the "OFF" position.  
Tape & reel packaging per EIA available for DMR models (see next page).

### SWITCH CROSS SECTIONS

Double  
contact system

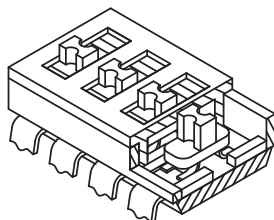

DI & DM

### SCHEMATIC (TYPICAL)

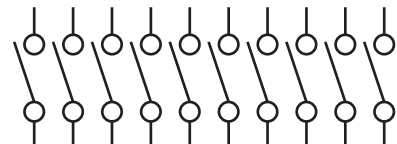

See tabulations on following pages for  
number of positions available (10 shown)

P

**NDI Series Machine Insertable †**

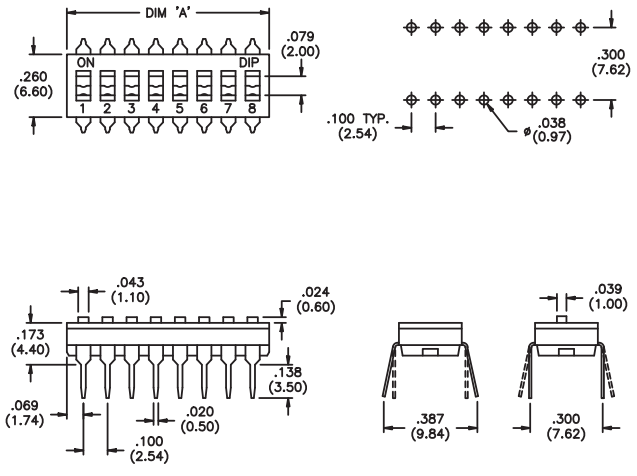

Actuator	Squared terminals		Spread terminals		No. of Pos.	'A' Dim. +.008/--.000" (+0.2/-0.0mm)
	MODEL NO. with no tape seal	MODEL NO. with tape seal	MODEL NO. with no tape seal	MODEL NO. with tape seal		
Raised	NDI01H	n/a	NDI01S	n/a	1	.137 (3,48)
	NDI02H	n/a	NDI02S	n/a	2	.237 (6,02)
	NDI04H	n/a	NDI04S	n/a	4	.437 (11,10)
	NDI06H	n/a	NDI06S	n/a	6	.637 (16,18)
	NDI08H	n/a	NDI08S	n/a	8	.837 (21,26)
Recessed	NDI10H	n/a	NDI10S	n/a	10	1.037 (26,34)
	NDIR01H	n/a	NDIR01S	n/a	1	.137 (3,48)
	NDIR02H	NDIR02HT	NDIR02S	NDIR02ST	2	.237 (6,02)
	NDIR04H	NDIR04HT	NDIR04S	NDIR04ST	4	.437 (11,10)
	NDIR06H	NDIR06HT	NDIR06S	NDIR06ST	6	.637 (16,18)
	NDIR08H	NDIR08HT	NDIR08S	NDIR08ST	8	.837 (21,26)
	NDIR10H	NDIR10HT	NDIR10S	NDIR10ST	10	1.037 (26,34)

† Auto-insertable using equipment from Amistar, Dynapert, Panasert, Northeastern Tool, Universal and others.

n/a = not available.

SPECIFICATIONS SUBJECT TO CHANGE WITHOUT NOTICE.

**P**

**DM Series Surface Mount †**

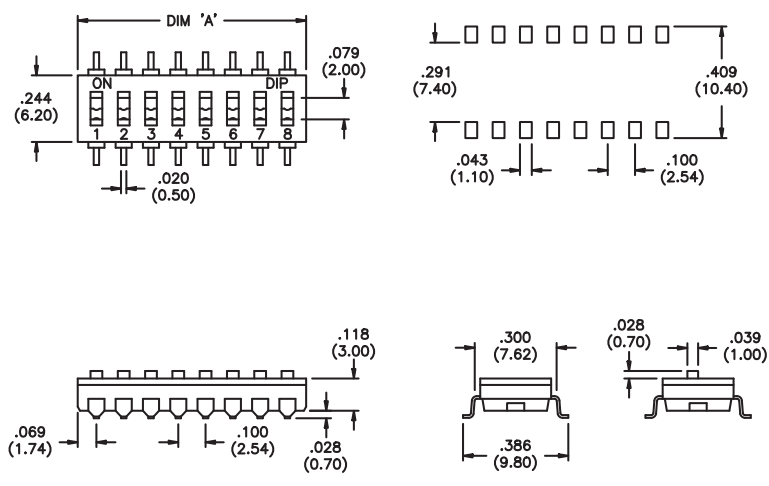

Actuator Style	MODEL NO. with no tape seal	MODEL NO. with tape seal	No. of Pos.	'A' Dimension +.008/--.000" (+0.2/-0.0mm)
Raised Actuator	DM01	n/a	1	.137 (3,48)
	DM02	n/a	2	.237 (6,02)
	DM03	n/a	3	.337 (8,56)
	DM04	n/a	4	.437 (11,10)
	DM05	n/a	5	.537 (13,64)
	DM06	n/a	6	.637 (16,18)
	DM07	n/a	7	.737 (18,72)
	DM08	n/a	8	.837 (21,26)
	DM09	n/a	9	.937 (23,80)
	DM10	n/a	10	1.037 (26,34)
	DM12	n/a	12	1.237 (31,42)
	Recessed Actuator	DMR01	n/a	1
DMR02		DMR02T	2	.237 (6,02)
DMR03		DMR03T	3	.337 (8,56)
DMR04		DMR04T	4	.437 (11,10)
DMR05		DMR05T	5	.537 (13,64)
DMR06		DMR06T	6	.637 (16,18)
DMR07		DMR07T	7	.737 (18,72)
DMR08		DMR08T	8	.837 (21,26)
DMR09		DMR09T	9	.937 (23,80)
DMR10		DMR10T	10	1.037 (26,34)
DMR12		DMR12T	12	1.237 (31,42)

For tape & reel packaging on DMR models only, add 'TR' to model number - example: DMR08TTR. Note- tape & reel packaging is available only with tape seal models. 900 switches per reel.

## Looking for pricing, stock, or lifecycle information?

Click below to explore more details on WIN SOURCE:

 [View DM10 on WIN SOURCE](#)

 [Apem Inc. Information](#)

## Optimize Your Supply Chain with WIN SOURCE Solutions

-  Global Sourcing Solution
-  Obsolete Management
-  Cost Control Management
-  Shortage Management
-  Alternative Solution
-  Excess Inventory Management