



**THE DATASHEET OF  
CDCU877AGQLT**



## FEATURES

- 1.8-V Phase Lock Loop Clock Driver for Double Data Rate (DDR II) Applications
- Spread Spectrum Clock Compatible
- Operating Frequency: 10 MHz to 400 MHz
- Low Current Consumption: <135 mA
- Low Jitter (Cycle-Cycle):  $\pm 30$  ps
- Low Output Skew: 35 ps
- Low Period Jitter:  $\pm 20$  ps
- Low Dynamic Phase Offset:  $\pm 15$  ps
- Low Static Phase Offset:  $\pm 50$  ps
- Distributes One Differential Clock Input to Ten Differential Outputs
- 52-Ball  $\mu$ BGA (MicroStar™ Junior BGA, 0,65-mm pitch) and 40-Pin MLF
- External Feedback Pins (FBIN,  $\overline{\text{FBIN}}$ ) are Used to Synchronize the Outputs to the Input Clocks
- Meets or Exceeds JESD82-8 PLL Standard for PC2-3200/4300
- Fail-Safe Inputs

## DESCRIPTION

The CDCU877 is a high-performance, low-jitter, low-skew, zero-delay buffer that distributes a differential clock input pair (CK,  $\overline{\text{CK}}$ ) to ten differential pairs of clock outputs ( $Y_n$ ,  $\overline{Y_n}$ ) and to one differential pair of feedback clock outputs (FBOUT,  $\overline{\text{FBOUT}}$ ). The clock outputs are controlled by the input clocks (CK,  $\overline{\text{CK}}$ ), the feedback clocks (FBIN,  $\overline{\text{FBIN}}$ ), the LVCMOS control pins (OE, OS), and the analog power input ( $AV_{DD}$ ). When OE is low, the clock outputs, except FBOUT/ $\overline{\text{FBOUT}}$ , are disabled while the internal PLL continues to maintain its locked-in frequency. OS (output select) is a program pin that must be tied to GND or  $V_{DD}$ . When OS is high, OE functions as previously described. When OS and OE are both low, OE has no effect on  $Y7/\overline{Y7}$ , they are free running. When  $AV_{DD}$  is grounded, the PLL is turned off and bypassed for test purposes.

When both clock inputs (CK,  $\overline{\text{CK}}$ ) are logic low, the device enters in a low power mode. An input logic detection circuit on the differential inputs, independent from input buffers, detects the logic low level and performs in a low power state where all outputs, the feedback, and the PLL are off. When the clock inputs transition from being logic low to being differential signals, the PLL turns back on, the inputs and the outputs are enabled, and the PLL obtains phase lock between the feedback clock pair (FBIN,  $\overline{\text{FBIN}}$ ) and the clock input pair (CK,  $\overline{\text{CK}}$ ) within the specified stabilization time.

The CDCU877 is able to track spread spectrum clocking (SSC) for reduced EMI. This device operates from  $-40^\circ\text{C}$  to  $85^\circ\text{C}$ .

## ORDERING INFORMATION

$T_A$	52-BALL BGA <sup>(1)</sup>	40-Pin MLF
-40°C to 85°C	CDCU877ZQL	CDCU877RHA
	CDCU877AZQL	CDCU877ARHA
	CDCU877GQL	CDCU877RTB
	CDCU877AGQL	CDCU877ARTB

- (1) For the most current package and ordering information, see the Package Option Addendum at the end of this document, or see the TI website at [www.ti.com](http://www.ti.com).



Please be aware that an important notice concerning availability, standard warranty, and use in critical applications of Texas Instruments semiconductor products and disclaimers thereto appears at the end of this data sheet.

MicroStar is a trademark of Texas Instruments.

# 1.8-V PHASE LOCK LOOP CLOCK DRIVER

SCAS688D–JUNE 2005–REVISED JULY 2007



These devices have limited built-in ESD protection. The leads should be shorted together or the device placed in conductive foam during storage or handling to prevent electrostatic damage to the MOS gates.

**MicroStar Junior (ZQL) Package  
(TOP VIEW)**

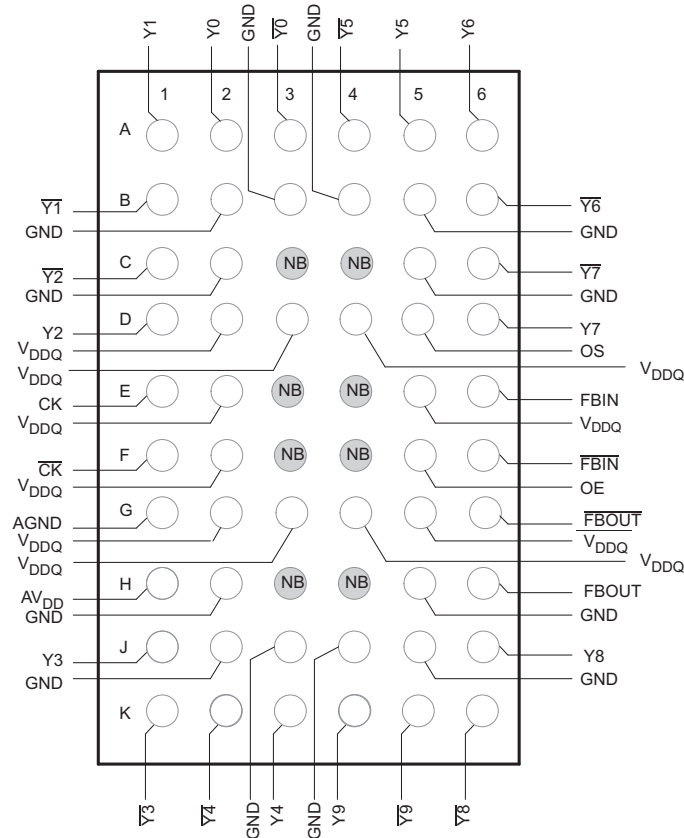

- A. NC = No Connection
- B. NB = No Ball

**RHA/RTB Package (MLF Package)  
(TOP VIEW)**

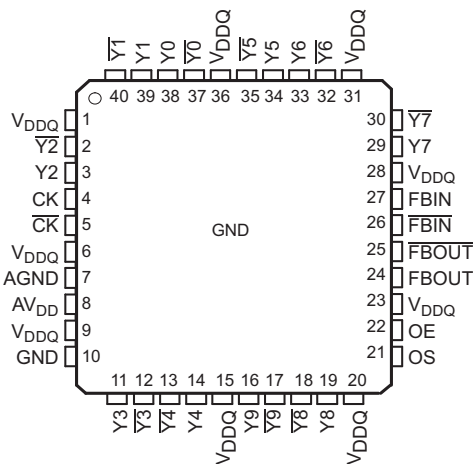

40-pin HP-VFQFP-N (6,0 x 6,0 mm Body Size,  
0,5 mm Pitch, M0#220, Variation VJJD-2,  
E2 = D2 = 2,9 mm ± 0,15 mm) Package Pinouts

**1.8-V PHASE LOCK LOOP CLOCK DRIVER**

SCAS688D–JUNE 2005–REVISED JULY 2007

**TERMINAL FUNCTIONS**

TERMINAL			I/O	DESCRIPTION
NAME	GQL/ZQL	RHA/RTB		
AGND	G1	7		Analog ground
AV <sub>DD</sub>	H1	8		Analog power
CK	E1	4	I	Clock input with a (10 kΩ to 100 kΩ) pulldown resistor
$\overline{\text{CK}}$	F1	5	I	Complementary clock input with a (10 kΩ to 100 kΩ) pulldown resistor
FBIN	E6	27	I	Feedback clock input
$\overline{\text{FBIN}}$	F6	26	I	Complementary feedback clock input
FBOU <sub>T</sub>	H6	24	O	Feedback clock output
$\overline{\text{FBOU}}\overline{\text{T}}$	G6	25	O	Complementary feedback clock output
OE	F5	22	I	Output enable (asynchronous)
OS	D5	21	I	Output select (tied to GND or V <sub>DD</sub> )
GND	B2, B3, B4, B5, C2, C5, H2, H5, J2, J3, J4, J5	10		Ground
V <sub>DDQ</sub>	D2, D3, D4, E2, E5, F2, G2, G3, G4, G5	1, 6, 9, 15, 20, 23, 28, 31, 36		Logic and output power
Y[0:9]	A2, A1, D1, J1, K3, A5, A6, D6, J6, K4	3, 11, 14, 16, 19, 29, 33, 34, 38, 39	O	Clock outputs
$\overline{\text{Y}}[0:9]$	A3, B1, C1, K1, K2, A4, B6, C6, K6, K5	2, 12, 13, 18, 17, 30, 32, 35, 37, 40	O	Complementary clock outputs

**FUNCTION TABLE**

INPUTS					OUTPUTS				
AVDD	OE	OS	CK	$\overline{\text{CK}}$	Y	$\overline{\text{Y}}$	FBOU <sub>T</sub>	$\overline{\text{FBOU}}\overline{\text{T}}$	PLL
GND	H	X	L	H	L	H	L	H	Bypassed/Off
GND	H	X	H	L	H	L	H	L	Bypassed/Off
GND	L	H	L	H	L <sub>Z</sub>	L <sub>Z</sub>	L	H	Bypassed/Off
GND	L	L	H	L	L <sub>Z</sub> Y7 Active	L <sub>Z</sub> $\overline{\text{Y}}\overline{7}$ Active	H	L	Bypassed/Off
1.8 V Nominal	L	H	L	H	L <sub>Z</sub>	L <sub>Z</sub>	L	H	On
1.8 V Nominal	L	L	H	L	L <sub>Z</sub> Y7 Active	L <sub>Z</sub> $\overline{\text{Y}}\overline{7}$ Active	H	L	On
1.8 V Nominal	H	X	L	H	L	H	L	H	On
1.8 V Nominal	H	X	H	L	H	L	H	L	On
1.8 V Nominal	X	X	L	L	L <sub>Z</sub>	L <sub>Z</sub>	L <sub>Z</sub>	L <sub>Z</sub>	Off
X	X	X	H	H	Reserved				

1.8-V PHASE LOCK LOOP CLOCK DRIVER

SCAS688D-JUNE 2005-REVISED JULY 2007

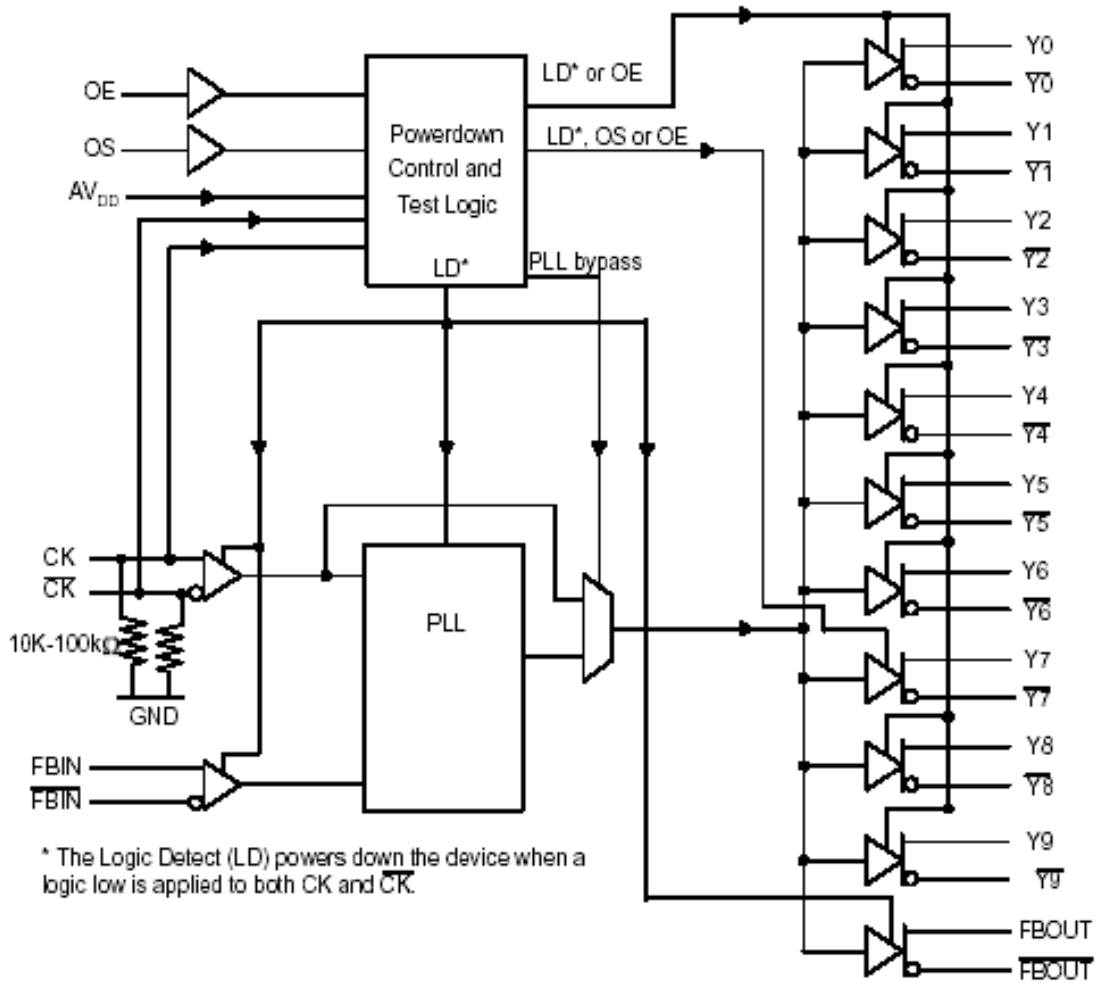

Figure 1. LOGIC DIAGRAM (POSITIVE LOGIC)

**Absolute Maximum Ratings<sup>(1)</sup>**

over operating free-air temperature range (unless otherwise noted)

			MIN	MAX	UNIT
V <sub>CC</sub>	Supply voltage range	V <sub>DDQ</sub> or AV <sub>DD</sub>	-0.5	2.5	V
V <sub>I</sub>	Input voltage range <sup>(2)(3)</sup>		-0.5	V <sub>DDQ</sub> + 0.5	V
V <sub>O</sub>	Output voltage range <sup>(2)(3)</sup>		-0.5	V <sub>DDQ</sub> + 0.5	V
I <sub>IK</sub>	Input clamp current	V <sub>I</sub> < 0 or V <sub>I</sub> > V <sub>DDQ</sub>		±50	mA
I <sub>OK</sub>	Output clamp current	V <sub>O</sub> < 0 or V <sub>O</sub> > V <sub>DDQ</sub>		±50	mA
I <sub>O</sub>	Continuous output current	V <sub>O</sub> = 0 to V <sub>DDQ</sub>		±50	mA
	Continuous current through each V <sub>DDQ</sub> or GND			±100	mA
T <sub>stg</sub>	Storage temperature range		-65	150	°C

- (1) Stresses beyond those listed under "absolute maximum ratings" may cause permanent damage to the device. These are stress ratings only, and functional operation of the device at these or any other conditions beyond those indicated under "recommended operating conditions" is not implied. Exposure to absolute-maximum-rated conditions for extended periods may affect device reliability.
- (2) The input and output voltage ratings may be exceeded if the input and output clamp-current ratings are observed.
- (3) This value is limited to 2.5 V maximum.

**Recommended Operating Conditions**

			MIN	NOM	MAX	UNIT
V <sub>CC</sub>	Output supply voltage, V <sub>DDQ</sub>		1.7	1.8	1.9	V
	Supply Voltage, AV <sub>DD</sub> <sup>(1)</sup>			V <sub>DDQ</sub>		V
V <sub>IL</sub>	Low-level input voltage <sup>(2)</sup>	OE, OS			0.35 x V <sub>DDQ</sub>	V
V <sub>IH</sub>	High-level input voltage <sup>(2)</sup>	CK, $\overline{CK}$	0.65 x V <sub>DDQ</sub>			V
I <sub>OH</sub>	High-level output current (see Figure 2)				-9	mA
I <sub>OL</sub>	Low-level output current (see Figure 2)				9	mA
V <sub>IX</sub>	Input differential-pair cross voltage		(V <sub>DDQ</sub> /2) - 0.15		(V <sub>DDQ</sub> /2) + 0.15	V
V <sub>I</sub>	Input voltage level		-0.3		V <sub>DDQ</sub> + 0.3	V
V <sub>ID</sub>	Input differential voltage <sup>(2)</sup> (see Figure 9)	DC	0.3		V <sub>DDQ</sub> + 0.4	V
		AC	0.6		V <sub>DDQ</sub> + 0.4	V
T <sub>A</sub>	Operating free-air temperature		-40		85	°C

- (1) The PLL is turned off and bypassed for test purposes when AV<sub>DD</sub> is grounded. During this test mode, V<sub>DDQ</sub> remains within the recommended operating conditions and no timing parameters are specified.
- (2) V<sub>ID</sub> is the magnitude of the difference between the input level on CK and the input level on  $\overline{CK}$ , see Figure 9 for definition. The CK and  $\overline{CK}$ , V<sub>IH</sub> and V<sub>IL</sub> limits define the dc low and high levels for the logic detect state.

# 1.8-V PHASE LOCK LOOP CLOCK DRIVER

SCAS688D–JUNE 2005–REVISED JULY 2007

## Electrical Characteristics

over recommended operating free-air temperature range (unless otherwise noted)

PARAMETER		TEST CONDITIONS	AV <sub>DD</sub> , V <sub>DDQ</sub>	MIN	TYP <sup>(1)</sup>	MAX	UNIT
V <sub>IK</sub>	Input	I <sub>I</sub> = 18 mA	1.7			-1.2	V
V <sub>OH</sub>	High-level output voltage	I <sub>OH</sub> = -100 μA	1.7 to 1.9	V <sub>DDQ</sub> - 0.2			V
		I <sub>OH</sub> = -9 mA	1.7	1.1			
V <sub>OL</sub>	Low-level output voltage	I <sub>OL</sub> = 100 μA				0.1	V
		I <sub>OL</sub> = 9 mA	1.7			0.6	
I <sub>O(DL)</sub>	Low-level output current, disabled	V <sub>O(DL)</sub> = 100 mV, OE = L	1.7	100			μA
V <sub>OD</sub>	Differential output voltage <sup>(1)</sup>		1.7	0.5			V
I <sub>I</sub>	Input current	CK, $\overline{CK}$	1.9			±250	μA
		OE, OS, FBIN, $\overline{FBIN}$	1.9			±10	
I <sub>DD(LD)</sub>	Supply current, static (I <sub>DDQ</sub> + I <sub>ADD</sub> )		1.9			500	μA
I <sub>DD</sub>	Supply current, dynamic (I <sub>DDQ</sub> + I <sub>ADD</sub> ) (see Note <sup>(2)</sup> for CPD calculation)	CK and $\overline{CK}$ = 270 MHz. All outputs are open (not connected to a PCB)	1.9			135	mA
		All outputs are loaded with 2 pF and 120-Ω termination resistor	1.9			235	
C <sub>I</sub>	Input capacitance	CK, $\overline{CK}$	V <sub>I</sub> = V <sub>DD</sub> or GND	1.8	2	3	pF
		FBIN, $\overline{FBIN}$		1.8	2	3	
C <sub>I(Δ)</sub>	Change in input current	CK, $\overline{CK}$	V <sub>I</sub> = V <sub>DD</sub> or GND	1.8		0.25	pF
		FBIN, $\overline{FBIN}$		1.8		0.25	

(1) V<sub>OD</sub> is the magnitude of the difference between the true and complimentary outputs. See Figure 9 for a definition.

(2) Total I<sub>DD</sub> = I<sub>DDQ</sub> + I<sub>ADD</sub> = f<sub>CK</sub> × C<sub>PD</sub> × V<sub>DDQ</sub>, solving for C<sub>PD</sub> = (I<sub>DDQ</sub> + I<sub>ADD</sub>)/(f<sub>CK</sub> × V<sub>DDQ</sub>) where f<sub>CK</sub> is the input frequency, V<sub>DDQ</sub> is the power supply, and C<sub>PD</sub> is the power dissipation capacitance.

## Timing Requirements

over recommended operating free-air temperature range (unless otherwise noted)<sup>(1)</sup>

PARAMETER		TEST CONDITIONS	MIN	MAX	UNIT
f <sub>CK</sub>	Clock frequency (operating) <sup>(1)(2)</sup>	AV <sub>DD</sub> , V <sub>DD</sub> = 1.8 V ±0.1 V	10	400	MHz
	Clock frequency (application) <sup>(1)(3)</sup>		160	340	MHz
t <sub>DC</sub>	Duty cycle, input clock		40%	60%	
t <sub>L</sub>	Stabilization time <sup>(4)</sup>			12	μs

(1) The PLL must be able to handle spread spectrum induced skew.

(2) Operating clock frequency indicates a range over which the PLL must be able to lock, but in which it is not required to meet the other timing parameters (used for low speed system debug).

(3) Application clock frequency indicates a range over which the PLL must meet all timing parameters.

(4) Stabilization time is the time required for the integrated PLL circuit to obtain phase lock of its feedback signal to its reference signal after power up. During normal operation, the stabilization time is also the time required for the integrated PLL circuit to obtain phase lock of its feedback signal to its reference signal when CK and  $\overline{CK}$  go to a logic low state, enter the power-down mode and later return to active operation. CK and  $\overline{CK}$  may be left floating after they have been driven low for one complete clock cycle.

**Switching Characteristics**

 over recommended operating free-air temperature range (unless otherwise noted) (see <sup>(1)</sup>)  $AV_{DD}, V_{DD} = 1.8\text{ V} \pm 0.1\text{ V}$ 

PARAMETER		TEST CONDITIONS	MIN	TYP	MAX	UNIT
$t_{en}$	Enable time, OE to any $Y/\bar{Y}$	See <a href="#">Figure 11</a>			8	ns
$t_{dis}$	Disable time, OE to any $Y/\bar{Y}$	See <a href="#">Figure 11</a>			8	ns
$t_{jit(cc+)}$ $t_{jit(cc-)}$	Cycle-to-cycle period jitter <sup>(2)</sup>	160 MHz to 190 MHz, see <a href="#">Figure 4</a>	0		40	ps
			0		-40	
$t_{jit(cc+)}$ $t_{jit(cc-)}$	Cycle-to-cycle period jitter <sup>(2)</sup>	160 MHz to 340 MHz, see <a href="#">Figure 4</a>	0		30	ps
			0		-30	
$t_{(w)}$	Static phase offset time <sup>(3)</sup>	See <a href="#">Figure 5</a>	-50		50	ps
$t_{(w)dyn}$	Dynamic phase offset time	See <a href="#">Figure 10</a>	-15		15	ps
$t_{sk(o)}$	Output clock skew	See <a href="#">Figure 6</a>			35	ps
$t_{jit(per)}$	Period jitter <sup>(4)(2)</sup>	160 MHz to 190 MHz, see <a href="#">Figure 7</a>	-30		30	ps
		190 MHz to 340 MHz, see <a href="#">Figure 7</a>	-20		20	
$t_{jit(hper)}$	Half-period jitter <sup>(4)(2)</sup>	160 MHz to 190 MHz, see <a href="#">Figure 8</a>	-115		115	ps
		190 MHz to 250 MHz, see <a href="#">Figure 8</a>	-70		70	
		250 MHz to 300 MHz, see <a href="#">Figure 8</a>	-40		40	
		300 MHz to 340 MHz, see <a href="#">Figure 8</a>	-60		60	
SR	Slew rate, OE	See <a href="#">Figure 3</a> and <a href="#">Figure 9</a>	0.5			V/ns
	Input clock slew rate	See <a href="#">Figure 3</a> and <a href="#">Figure 9</a>	1	2.5	4	
	Output clock slew rate <sup>(5)(6)</sup> (no load)	See <a href="#">Figure 3</a> and <a href="#">Figure 9</a>	1.5	2.5	3	
$V_{OX}$	Output differential-pair cross voltage <sup>(7)</sup>	CDCU877, See <a href="#">Figure 2</a>	$(V_{DDQ}/2) - 0.1$		$(V_{DDQ}/2) + 0.1$	V
		CDCU877A <sup>(8)</sup> , See <a href="#">Figure 2</a> (0 - 85°C)	$(V_{DDQ}/2) - 0.1$		$(V_{DDQ}/2) + 0.1$	
	SSC modulation frequency		30		33	kHz
	SSC clock input frequency deviation		0%		-0.5%	
	PLL loop bandwidth		2			MHz

- (1) There are two different terminations that are used with the following tests. The load/board in [Figure 2](#) is used to measure the input and output differential-pair cross voltage only. The load/board in [Figure 3](#) is used to measure all other tests. For consistency, equal length cables must be used.
- (2) This parameter is specified by design and characterization.
- (3) Phase static offset time does not include jitter.
- (4) Period jitter, half-period jitter specifications are separate specifications that must be met independently of each other.
- (5) The output slew rate is determined from the IBIS model with a 120- $\Omega$  load only.
- (6) To eliminate the impact of input slew rates on static phase offset, the input skew rates of reference clock input CK and  $\bar{CK}$  and feedback clock inputs FBIN and  $\bar{FBIN}$  are recommended to be nearly equal. The 2.5-V/ns skew rates are shown as a recommended target. Compliance with these typical values is not mandatory if it can adequately shown that alternative characteristics meet the requirements of the registered DDR2 DIMM application.
- (7) Output differential-pair cross voltage specified at the DRAM clock input or the test load.
- (8)  $V_{OX}$  of CDCU877A is on average 30 mV lower than that of CDCU877 for the same application.

# 1.8-V PHASE LOCK LOOP CLOCK DRIVER

SCAS688D—JUNE 2005—REVISED JULY 2007

## PARAMETER MEASUREMENT INFORMATION

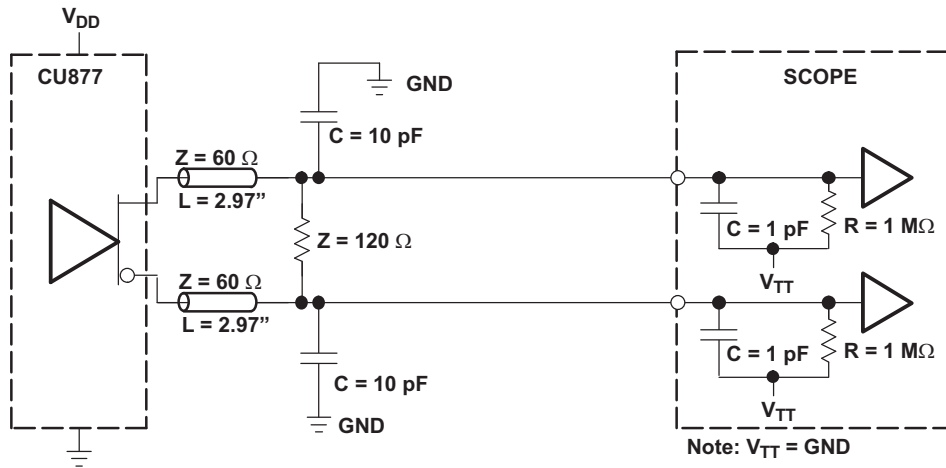

Figure 2. Output Load Test Circuit 1

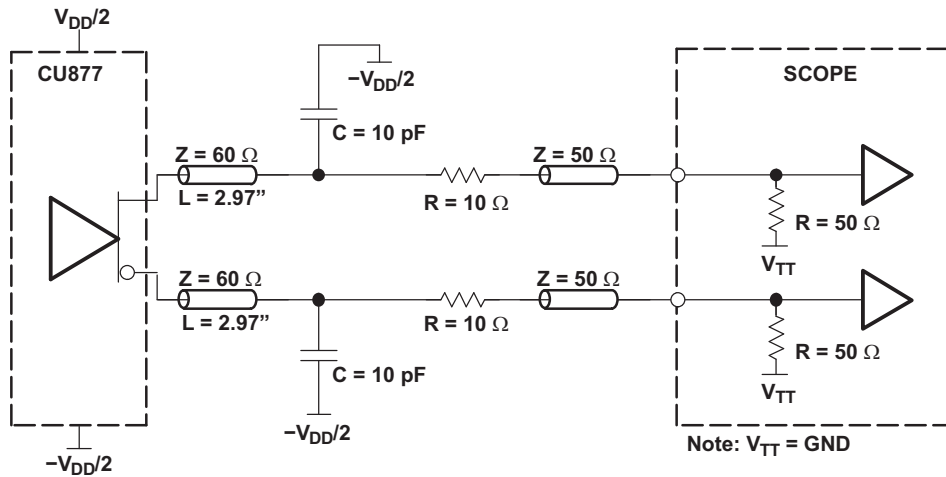

Figure 3. Output Load Test Circuit 2

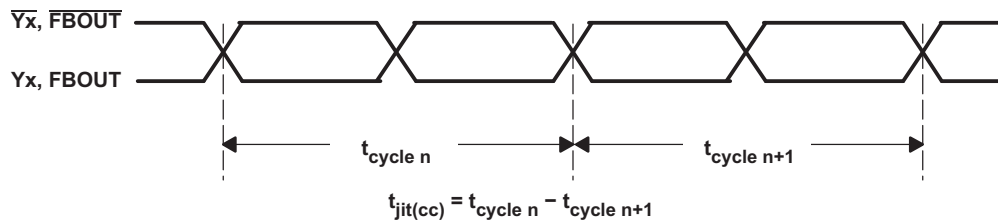

Figure 4. Cycle-To-Cycle Period Jitter

PARAMETER MEASUREMENT INFORMATION (continued)

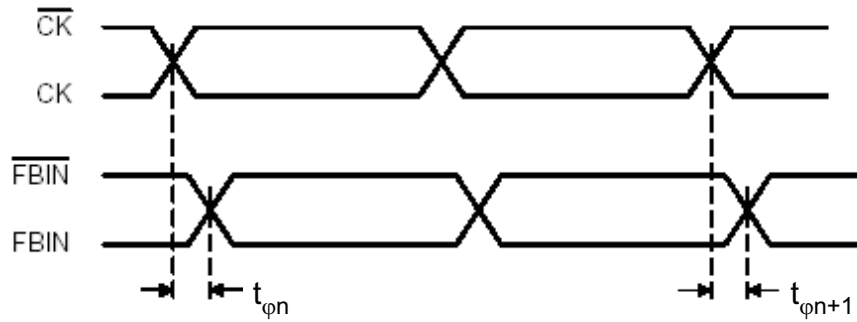

Figure 5. Static Phase Offset

$$t_{\phi} = \frac{\sum_{n=1}^N t_{\phi n}}{N}$$

(N is the large number of samples)

(N > 1000 samples)

(1)

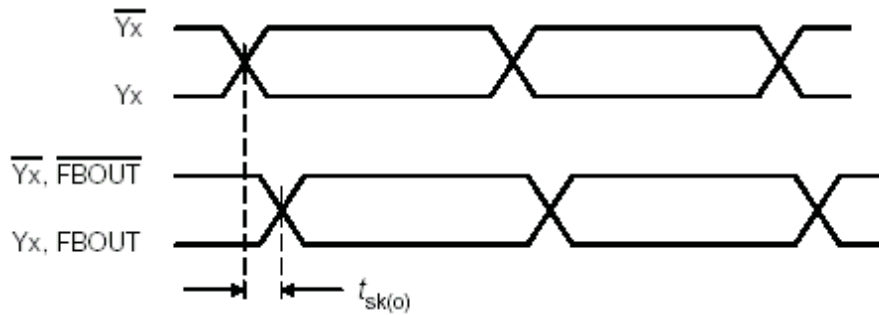

Figure 6. Output Skew

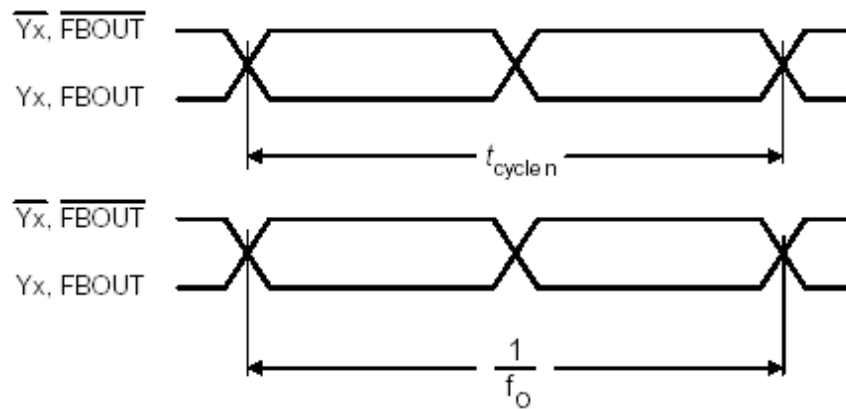

Figure 7. Period Jitter

$$t_{jit(per)} = t_{cycle\ n} - \frac{1}{f_0}$$

( $f_0$  average input frequency measured at CK/ $\overline{CK}$ )

(2)

1.8-V PHASE LOCK LOOP CLOCK DRIVER

SCAS688D–JUNE 2005–REVISED JULY 2007

PARAMETER MEASUREMENT INFORMATION (continued)

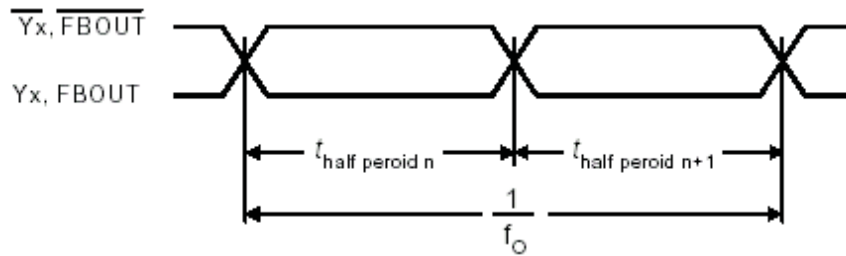

Figure 8. Half-Period Jitter

$$t_{jit(hper)} = t_{half\ period\ n} - \frac{1}{2 \times f_0}$$

n = any half cycle

(f<sub>0</sub> average input frequency measured at CK/ $\overline{CK}$ )

(3)

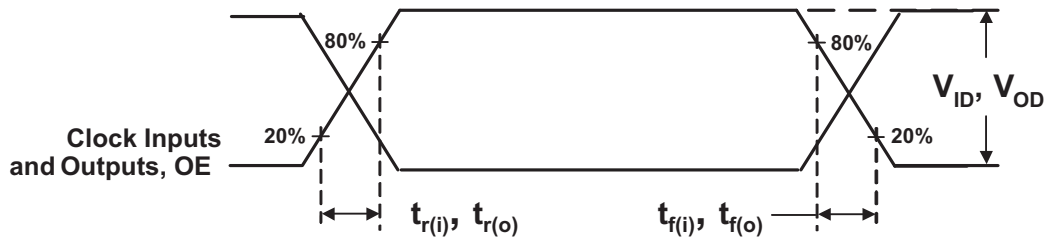

Figure 9. Input and Output Slew Rates

$$slrr_{(i/o)} = \frac{V_{80\%} - V_{20\%}}{t_{r(i/o)}}$$

$$slrf_{(i/o)} = \frac{V_{80\%} - V_{20\%}}{t_{f(i/o)}}$$

(4)

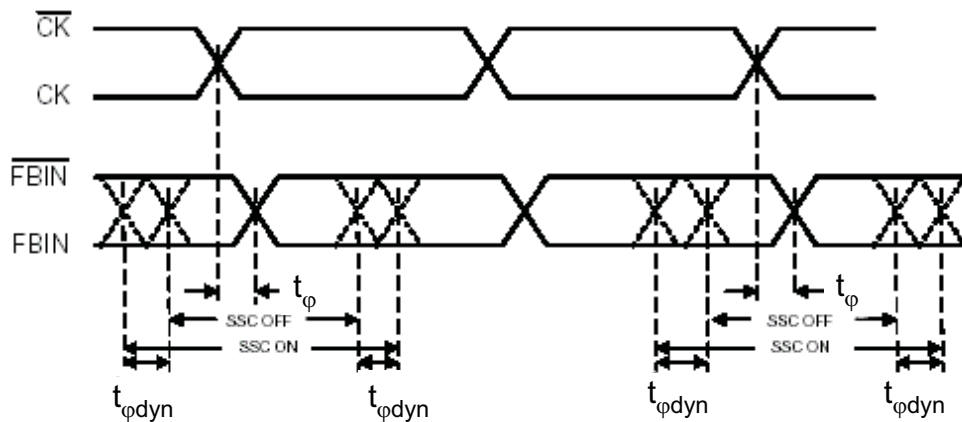

Figure 10. Dynamic Phase Offset

PARAMETER MEASUREMENT INFORMATION (continued)

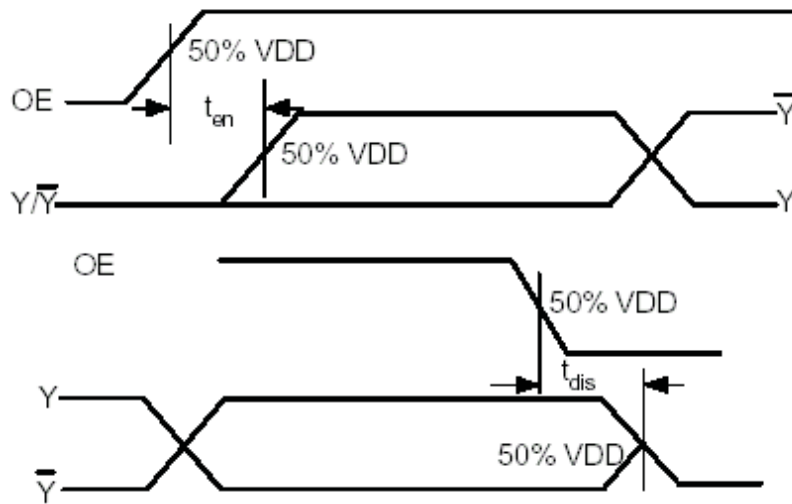
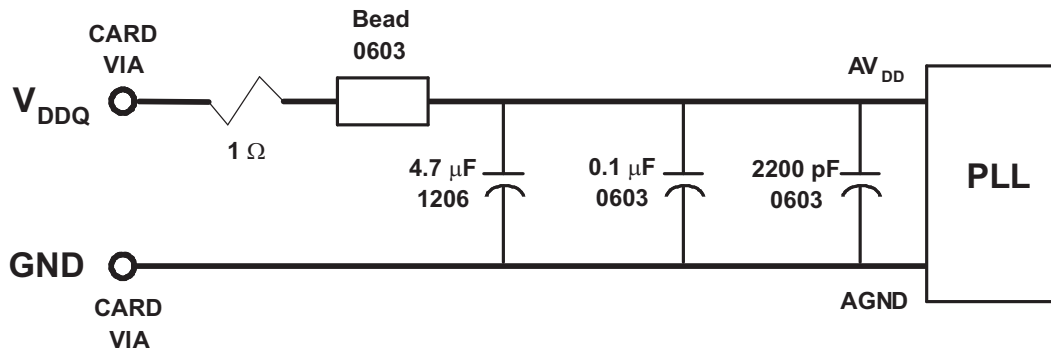

Figure 11. Time Delay Between OE and Clock Output (Y,  $\bar{Y}$ )

RECOMMENDED AV<sub>DD</sub> FILTERING



- Place the 2200-pF capacitor close to the PLL.
- Use a wide trace for the PLL analog power and ground. Connect PLL and capacitors to AGND trace and connect trace to one GND via (farthest from the PLL).
- Recommended bead: Fair-Rite PN 2506036017Y0 or equivalent (0.8 Ω dc maximum, 600 Ω at 100 MHz).

Figure 12. Recommended AV<sub>DD</sub> Filtering

**PACKAGING INFORMATION**

Orderable Device	Status (1)	Package Type	Package Drawing	Pins	Package Qty	Eco Plan (2)	Lead/Ball Finish (6)	MSL Peak Temp (3)	Op Temp (°C)	Device Marking (4/5)	Samples
CDCU877ARHAR	ACTIVE	VQFN	RHA	40	2500	Green (RoHS & no Sb/Br)	CU NIPDAU	Level-3-260C-168 HR	-40 to 85	CDCU877A	<a href="#">Samples</a>
CDCU877ARHARG4	ACTIVE	VQFN	RHA	40	2500	Green (RoHS & no Sb/Br)	CU NIPDAU	Level-3-260C-168 HR	-40 to 85	CDCU877A	<a href="#">Samples</a>
CDCU877ARHAT	ACTIVE	VQFN	RHA	40	250	Green (RoHS & no Sb/Br)	CU NIPDAU	Level-3-260C-168 HR	-40 to 85	CDCU877A	<a href="#">Samples</a>
CDCU877AZQLR	ACTIVE	BGA MICROSTAR JUNIOR	ZQL	52	1000	Green (RoHS & no Sb/Br)	SNAGCU	Level-2-260C-1 YEAR	-40 to 85	CDCU877A	<a href="#">Samples</a>
CDCU877AZQLT	ACTIVE	BGA MICROSTAR JUNIOR	ZQL	52	250	Green (RoHS & no Sb/Br)	SNAGCU	Level-2-260C-1 YEAR	-40 to 85	CDCU877A	<a href="#">Samples</a>
CDCU877GQLT	LIFEBUY	BGA MICROSTAR JUNIOR	GQL	52	250	TBD	SNPB	Level-2-235C-1 YEAR	-40 to 85	CDCU877	
CDCU877RHAR	ACTIVE	VQFN	RHA	40	2500	Green (RoHS & no Sb/Br)	CU NIPDAU	Level-3-260C-168 HR	-40 to 85	CDCU877	<a href="#">Samples</a>
CDCU877RHARG4	ACTIVE	VQFN	RHA	40	2500	Green (RoHS & no Sb/Br)	CU NIPDAU	Level-3-260C-168 HR	-40 to 85	CDCU877	<a href="#">Samples</a>
CDCU877RHAT	ACTIVE	VQFN	RHA	40	250	Green (RoHS & no Sb/Br)	CU NIPDAU	Level-3-260C-168 HR	-40 to 85	CDCU877	<a href="#">Samples</a>
CDCU877RHATG4	ACTIVE	VQFN	RHA	40	250	Green (RoHS & no Sb/Br)	CU NIPDAU	Level-3-260C-168 HR	-40 to 85	CDCU877	<a href="#">Samples</a>
CDCU877RTBR	ACTIVE	VQFN	RHA	40	2500	Green (RoHS & no Sb/Br)	CU NIPDAU	Level-3-260C-168 HR	-40 to 85	CDCU877	<a href="#">Samples</a>
CDCU877ZQLR	LIFEBUY	BGA MICROSTAR JUNIOR	ZQL	52	1000	Green (RoHS & no Sb/Br)	SNAGCU	Level-2-260C-1 YEAR	-40 to 85	CDCU877	

(1) The marketing status values are defined as follows:

**ACTIVE:** Product device recommended for new designs.

**LIFEBUY:** TI has announced that the device will be discontinued, and a lifetime-buy period is in effect.

**NRND:** Not recommended for new designs. Device is in production to support existing customers, but TI does not recommend using this part in a new design.

**PREVIEW:** Device has been announced but is not in production. Samples may or may not be available.

**OBsolete:** TI has discontinued the production of the device.

---

(2) **RoHS:** TI defines "RoHS" to mean semiconductor products that are compliant with the current EU RoHS requirements for all 10 RoHS substances, including the requirement that RoHS substance do not exceed 0.1% by weight in homogeneous materials. Where designed to be soldered at high temperatures, "RoHS" products are suitable for use in specified lead-free processes. TI may reference these types of products as "Pb-Free".

**RoHS Exempt:** TI defines "RoHS Exempt" to mean products that contain lead but are compliant with EU RoHS pursuant to a specific EU RoHS exemption.

**Green:** TI defines "Green" to mean the content of Chlorine (Cl) and Bromine (Br) based flame retardants meet JS709B low halogen requirements of  $\leq 1000$ ppm threshold. Antimony trioxide based flame retardants must also meet the  $\leq 1000$ ppm threshold requirement.

(3) MSL, Peak Temp. - The Moisture Sensitivity Level rating according to the JEDEC industry standard classifications, and peak solder temperature.

(4) There may be additional marking, which relates to the logo, the lot trace code information, or the environmental category on the device.

(5) Multiple Device Markings will be inside parentheses. Only one Device Marking contained in parentheses and separated by a "~" will appear on a device. If a line is indented then it is a continuation of the previous line and the two combined represent the entire Device Marking for that device.

(6) Lead/Ball Finish - Orderable Devices may have multiple material finish options. Finish options are separated by a vertical ruled line. Lead/Ball Finish values may wrap to two lines if the finish value exceeds the maximum column width.

**Important Information and Disclaimer:** The information provided on this page represents TI's knowledge and belief as of the date that it is provided. TI bases its knowledge and belief on information provided by third parties, and makes no representation or warranty as to the accuracy of such information. Efforts are underway to better integrate information from third parties. TI has taken and continues to take reasonable steps to provide representative and accurate information but may not have conducted destructive testing or chemical analysis on incoming materials and chemicals. TI and TI suppliers consider certain information to be proprietary, and thus CAS numbers and other limited information may not be available for release.

In no event shall TI's liability arising out of such information exceed the total purchase price of the TI part(s) at issue in this document sold by TI to Customer on an annual basis.

**TAPE AND REEL INFORMATION**

**QUADRANT ASSIGNMENTS FOR PIN 1 ORIENTATION IN TAPE**

\*All dimensions are nominal

Device	Package Type	Package Drawing	Pins	SPQ	Reel Diameter (mm)	Reel Width W1 (mm)	A0 (mm)	B0 (mm)	K0 (mm)	P1 (mm)	W (mm)	Pin1 Quadrant
CDCU877ARHAR	VQFN	RHA	40	2500	330.0	16.4	6.3	6.3	1.1	12.0	16.0	Q2
CDCU877ARHAT	VQFN	RHA	40	250	180.0	16.4	6.3	6.3	1.1	12.0	16.0	Q2
CDCU877AZQLR	BGA MICROSTAR JUNIOR	ZQL	52	1000	330.0	16.4	4.8	7.3	1.5	8.0	16.0	Q1
CDCU877AZQLT	BGA MICROSTAR JUNIOR	ZQL	52	250	180.0	16.4	4.8	7.3	1.5	8.0	16.0	Q1
CDCU877GQLT	BGA MICROSTAR JUNIOR	GQL	52	250	180.0	16.4	4.8	7.3	1.5	8.0	16.0	Q1
CDCU877RHAR	VQFN	RHA	40	2500	330.0	16.4	6.3	6.3	1.1	12.0	16.0	Q2
CDCU877RHAT	VQFN	RHA	40	250	180.0	16.4	6.3	6.3	1.1	12.0	16.0	Q2
CDCU877ZQLR	BGA MICROSTAR JUNIOR	ZQL	52	1000	330.0	16.4	4.8	7.3	1.5	8.0	16.0	Q1

**TAPE AND REEL BOX DIMENSIONS**

\*All dimensions are nominal

Device	Package Type	Package Drawing	Pins	SPQ	Length (mm)	Width (mm)	Height (mm)
CDCU877ARHAR	VQFN	RHA	40	2500	367.0	367.0	38.0
CDCU877ARHAT	VQFN	RHA	40	250	210.0	185.0	35.0
CDCU877AZQLR	BGA MICROSTAR JUNIOR	ZQL	52	1000	350.0	350.0	43.0
CDCU877AZQLT	BGA MICROSTAR JUNIOR	ZQL	52	250	213.0	191.0	55.0
CDCU877GQLT	BGA MICROSTAR JUNIOR	GQL	52	250	213.0	191.0	55.0
CDCU877RHAR	VQFN	RHA	40	2500	367.0	367.0	38.0
CDCU877RHAT	VQFN	RHA	40	250	210.0	185.0	35.0
CDCU877ZQLR	BGA MICROSTAR JUNIOR	ZQL	52	1000	350.0	350.0	43.0

RHA (S-PVQFN-N40)

PLASTIC QUAD FLATPACK NO-LEAD

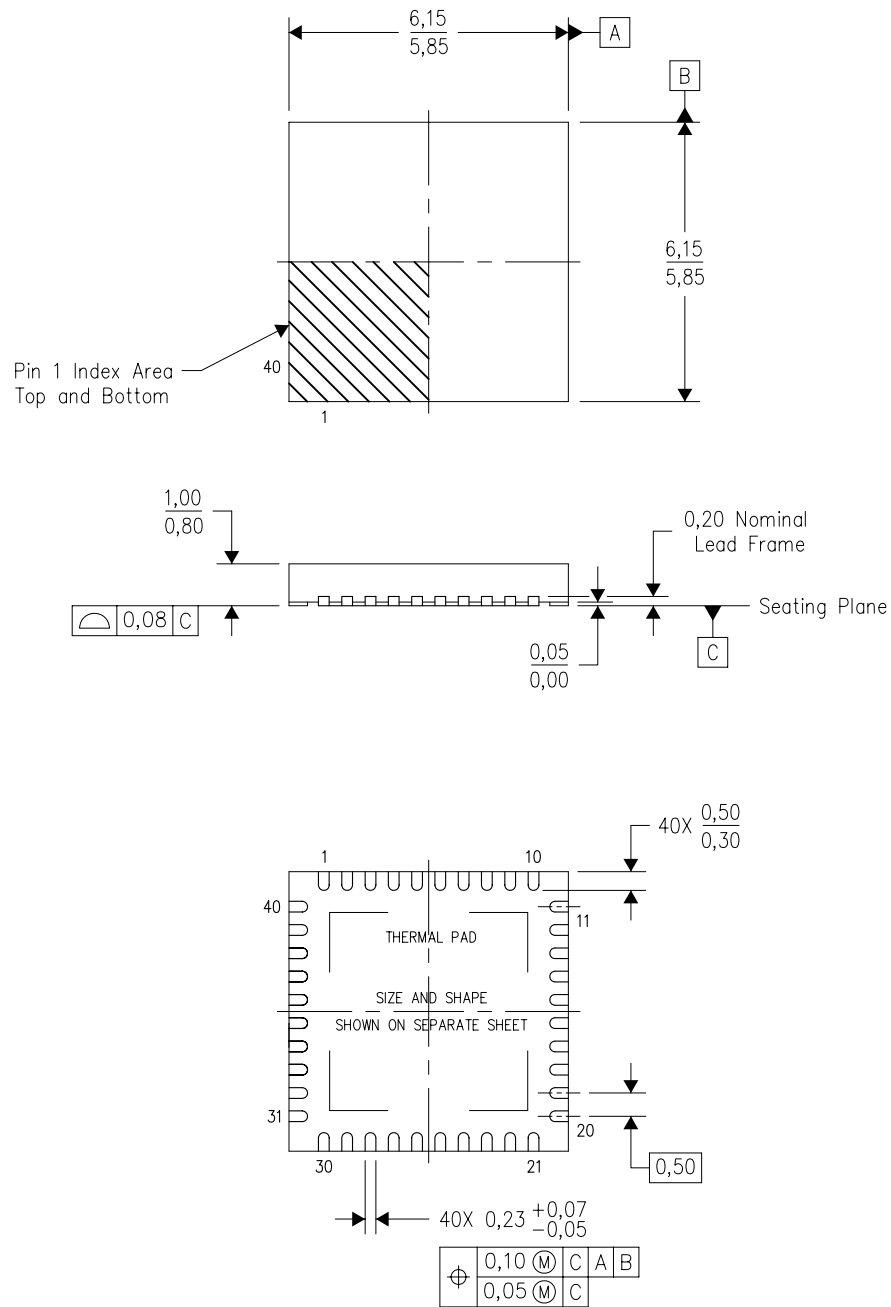

Bottom View

4204276/E 06/11

- NOTES:
- All linear dimensions are in millimeters. Dimensioning and tolerancing per ASME Y14.5M-1994.
  - This drawing is subject to change without notice.
  - QFN (Quad Flatpack No-Lead) Package configuration.
  - The package thermal pad must be soldered to the board for thermal and mechanical performance.
  - See the additional figure in the Product Data Sheet for details regarding the exposed thermal pad features and dimensions.
  - Package complies to JEDEC MO-220 variation VJJD-2.

# THERMAL PAD MECHANICAL DATA

RHA (S-PVQFN-N40)

PLASTIC QUAD FLATPACK NO-LEAD

## THERMAL INFORMATION

This package incorporates an exposed thermal pad that is designed to be attached directly to an external heatsink. The thermal pad must be soldered directly to the printed circuit board (PCB). After soldering, the PCB can be used as a heatsink. In addition, through the use of thermal vias, the thermal pad can be attached directly to the appropriate copper plane shown in the electrical schematic for the device, or alternatively, can be attached to a special heatsink structure designed into the PCB. This design optimizes the heat transfer from the integrated circuit (IC).

For information on the Quad Flatpack No-Lead (QFN) package and its advantages, refer to Application Report, QFN/SON PCB Attachment, Texas Instruments Literature No. SLUA271. This document is available at [www.ti.com](http://www.ti.com).

The exposed thermal pad dimensions for this package are shown in the following illustration.

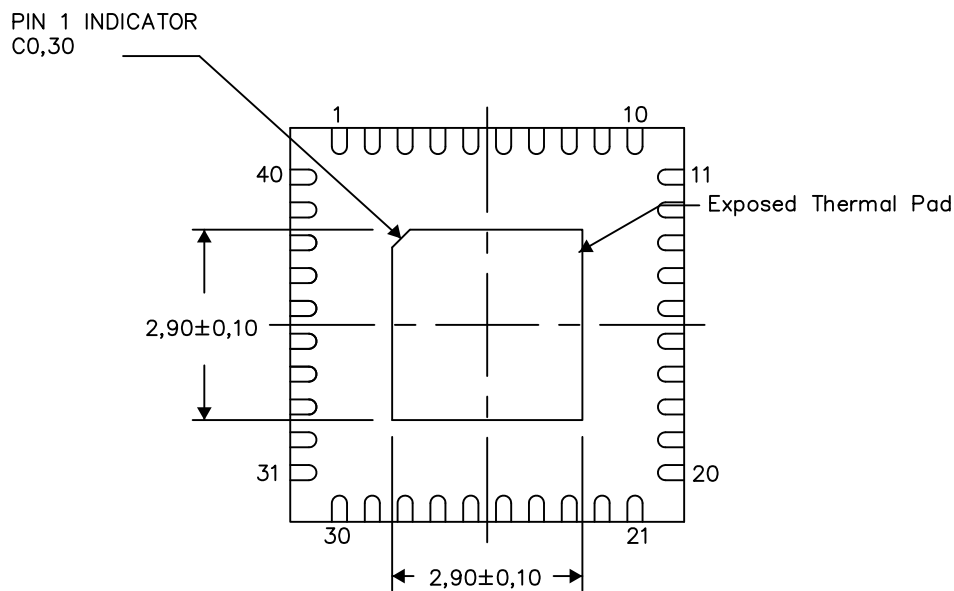

Bottom View

Exposed Thermal Pad Dimensions

4206355-3/X 08/14

NOTES: A. All linear dimensions are in millimeters

RHA (S-PVQFN-N40)

PLASTIC QUAD FLATPACK NO-LEAD

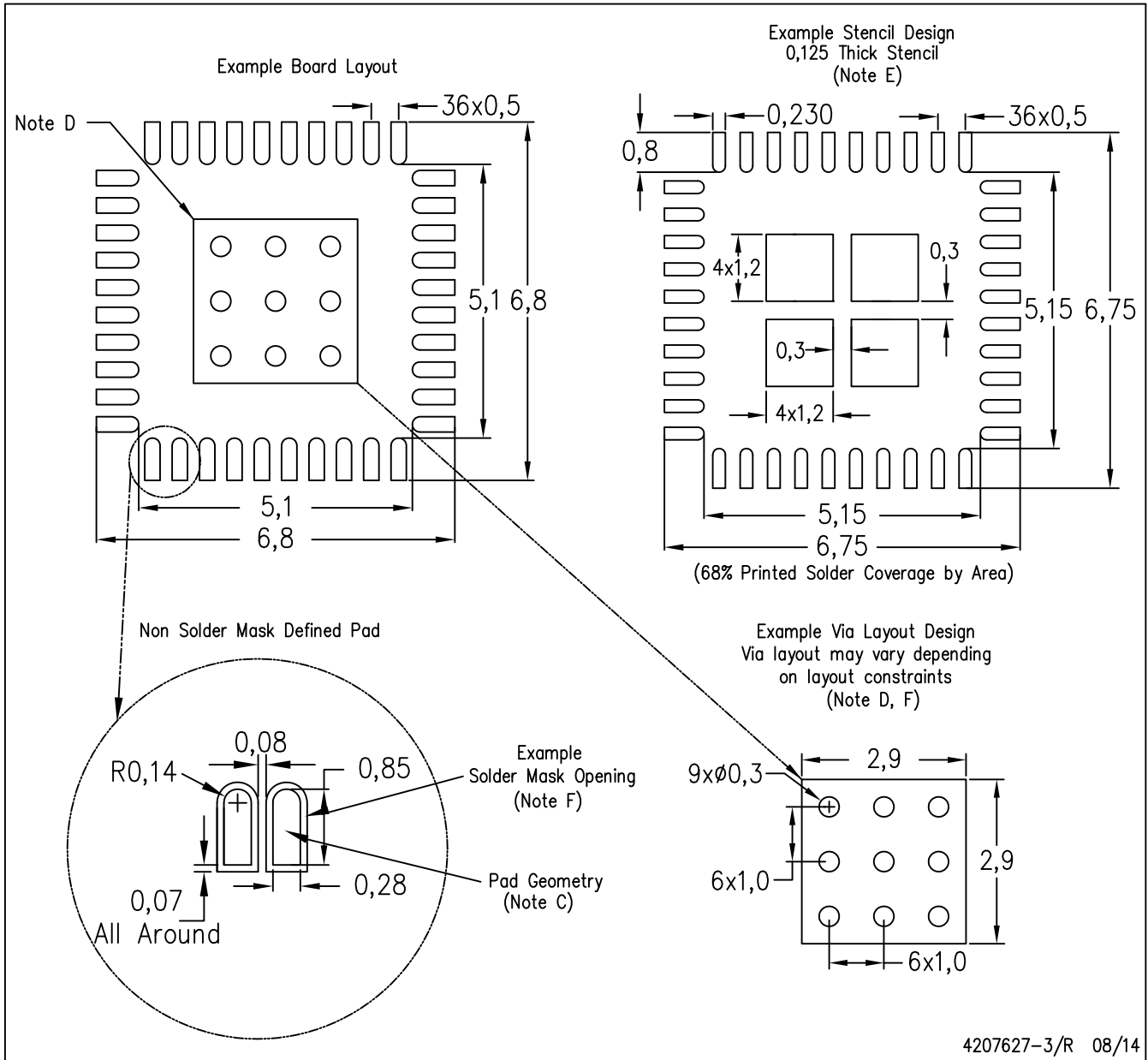

- NOTES:
- A. All linear dimensions are in millimeters.
  - B. This drawing is subject to change without notice.
  - C. Publication IPC-7351 is recommended for alternate designs.
  - D. This package is designed to be soldered to a thermal pad on the board. Refer to Application Note, Quad Flat-Pack Packages, Texas Instruments Literature No. SLUA271, and also the Product Data Sheets for specific thermal information, via requirements, and recommended board layout. These documents are available at [www.ti.com](http://www.ti.com) <<http://www.ti.com>>.
  - E. Laser cutting apertures with trapezoidal walls and also rounding corners will offer better paste release. Customers should contact their board assembly site for stencil design recommendations. Refer to IPC 7525 for stencil design considerations.
  - F. Customers should contact their board fabrication site for recommended solder mask tolerances and via tenting recommendations for vias placed in the thermal pad.



GQL (R-PBGA-N52)

PLASTIC BALL GRID ARRAY

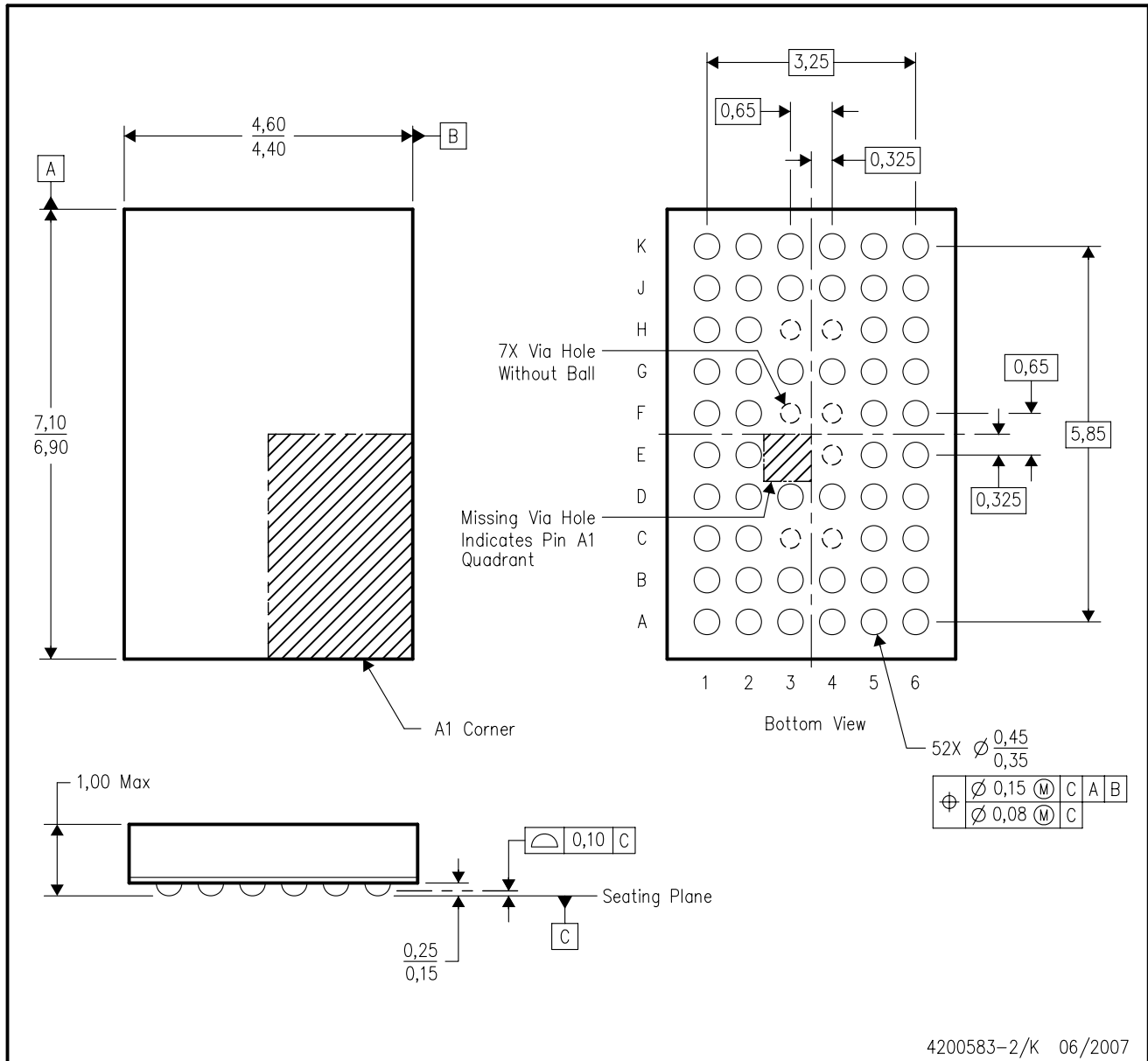

- NOTES:
- A. All linear dimensions are in millimeters. Dimensioning and tolerancing per ASME Y14.5M-1994.
  - B. This drawing is subject to change without notice.
  - C. Falls within JEDEC MO-285 variation BA-2.
  - D. This package is tin-lead (SnPb). Refer to the 52 ZQL package (drawing 4204437) for lead-free.

## IMPORTANT NOTICE AND DISCLAIMER

TI PROVIDES TECHNICAL AND RELIABILITY DATA (INCLUDING DATASHEETS), DESIGN RESOURCES (INCLUDING REFERENCE DESIGNS), APPLICATION OR OTHER DESIGN ADVICE, WEB TOOLS, SAFETY INFORMATION, AND OTHER RESOURCES "AS IS" AND WITH ALL FAULTS, AND DISCLAIMS ALL WARRANTIES, EXPRESS AND IMPLIED, INCLUDING WITHOUT LIMITATION ANY IMPLIED WARRANTIES OF MERCHANTABILITY, FITNESS FOR A PARTICULAR PURPOSE OR NON-INFRINGEMENT OF THIRD PARTY INTELLECTUAL PROPERTY RIGHTS.

These resources are intended for skilled developers designing with TI products. You are solely responsible for (1) selecting the appropriate TI products for your application, (2) designing, validating and testing your application, and (3) ensuring your application meets applicable standards, and any other safety, security, or other requirements. These resources are subject to change without notice. TI grants you permission to use these resources only for development of an application that uses the TI products described in the resource. Other reproduction and display of these resources is prohibited. No license is granted to any other TI intellectual property right or to any third party intellectual property right. TI disclaims responsibility for, and you will fully indemnify TI and its representatives against, any claims, damages, costs, losses, and liabilities arising out of your use of these resources.

TI's products are provided subject to TI's Terms of Sale ([www.ti.com/legal/termsofsale.html](http://www.ti.com/legal/termsofsale.html)) or other applicable terms available either on [ti.com](http://ti.com) or provided in conjunction with such TI products. TI's provision of these resources does not expand or otherwise alter TI's applicable warranties or warranty disclaimers for TI products.

Mailing Address: Texas Instruments, Post Office Box 655303, Dallas, Texas 75265  
Copyright © 2019, Texas Instruments Incorporated

## Looking for pricing, stock, or lifecycle information?

Click below to explore more details on WIN SOURCE:

 [View CDCU877AGQLT](#) on WIN SOURCE

 [Texas Instruments](#) Information

## Optimize Your Supply Chain with WIN SOURCE Solutions

-  Global Sourcing Solution
-  Obsolete Management
-  Cost Control Management
-  Shortage Management
-  Alternative Solution
-  Excess Inventory Management