



THE DATASHEET OF BA3308FV



Audio Accessory ICs

Preamps with Built-in ALC

BA3308F,BA3308FV

No.11087ECT01

●Description

The BA3308F/FV is a dual preamplifier for recording and playback with ALC (auto level control), developed for stereo radio, cassette recorders, tape recorders, and other pre amplifiers audio applications.

ALC circuit has a build in rectification circuit with wide adjustable dynamic range, high gain, low distortion amplifiers with direct coupling and mute circuit, used to cut off pop noise during power on.

Available in SOP14, or SSOP-B14 Packages.

●Features

- 1) Built-in ALC rectification diode
- 2) Wide operating power supply voltage range ($V_{CC}=4.5\sim 14\text{ V}$)
- 3) Low current consumption ($I_Q=3.5\text{mA}$)
- 4) High gain ($G_{VO}=80\text{dB}$)
- 5) Low distortion ($\text{THD}=0.1\%$)
- 6) Low noise ($V_{NIN}=1\ \mu\text{V}_{\text{rms}}$)
- 7) Input coupling capacitor not needed
- 8) Good ALC channel balance
- 9) Built-in power supply mute circuit
- 10) Dynamic range of ALC can be changed by attaching input resistance.

●Applications

Stereo radio, cassette tape recorders, stereo cassette decks, home stereos, music centers, etc.

●Line up matrix

Part No.	BA3308F	BA3308FV
Package	SOP14	SSOP-B14

● **Absolute maximum ratings**($T_a=25^\circ\text{C}$)

Parameter	Symbol	Limits	Unit
Supply voltage	V_{CC}	16	V
Power dissipation	BA3308F	450 ^{*1}	mW
	BA3308FV	350 ^{*2}	
Operating temperature	T_{opr}	$-25 \sim +75$	$^\circ\text{C}$
Storage temperature	T_{stg}	$-55 \sim +125$	$^\circ\text{C}$

*1 Reduce by 4.5 mW/ $^\circ\text{C}$ over 25 $^\circ\text{C}$, when mounted on a 70mm × 70mm × 1.6mm PCB board.

*2 Reduce by 3.5 mW/ $^\circ\text{C}$ over 25 $^\circ\text{C}$

● **Operating conditions**($T_a=25^\circ\text{C}$)

Parameter	Symbol	Min.	Typ.	Max.	Unit
Supply voltage	V_{CC}	4.5	-	14	V

Note: This IC is not designed to be radiation-resistant.

● **Electrical characteristics**(Unless otherwise noted, $T_a=25^\circ\text{C}$, $V_{CC}=7.0\text{V}$, $f=1\text{kHz}$, BPF20~20kHz)

Parameter	Symbol	Min.	Typ.	Max.	Unit	Conditions	Test Circuit
Quiescent current	I_Q	1.5	3.5	4.5	mA	$V_{IN}=0V_{rms}$	Fig.17
Open loop voltage gain	G_{VO}	70	80	-	dB	$V_{OUT}=-10\text{dBV}$	Fig.17
Total harmonic distortion	THD	-	0.1	0.3	%	NAB34dB, $V_{OUT}=40mV_{rms}$	Fig.17
Input resistance	R_{IN}	15	25	45	k Ω		Fig.17
Maximum output voltage	V_{OM}	0.6	1.2	-	V_{rms}	THD=1%	Fig.17
Input conversion noise voltage	V_{NIN}	-	1	2	μV_{rms}	$R_g=2.2k\Omega$, referenced to NAB 34dB at 1kHz	Fig.17
ALC range	ALC	40	45	-	dB	$R_g=3.9k\Omega$, $V_{IN}=-70\text{dBV}$ standard, THD=3%	Fig.17
ALC channel balance	ΔALC	-	0	2.5	dB	$V_{IN}=-60\text{dBV}, -30\text{dBV}$	Fig.17
Channel separation	CS	60	75	-	dB	$V_O=0\text{dBV}$, NAB 34dB	Fig.17

●Block diagram

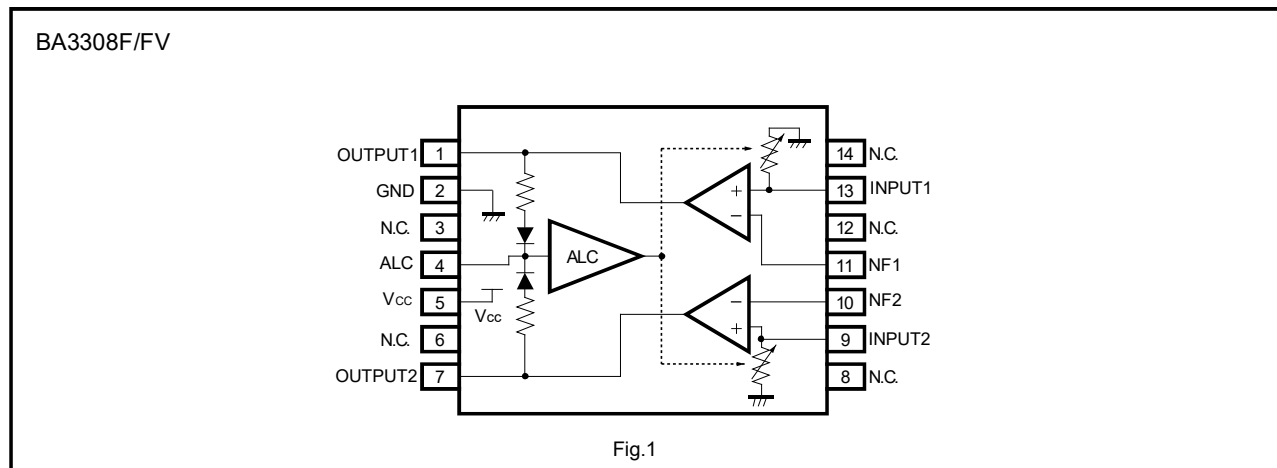

●Electrical characteristic curves (Reference data)

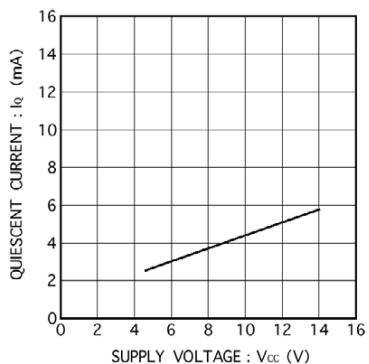

Fig.2 Quiescent current vs. power supply voltage

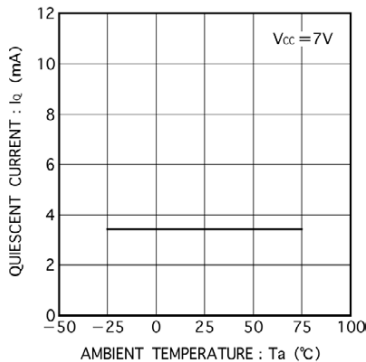

Fig.3 Quiescent current vs. ambient temperature

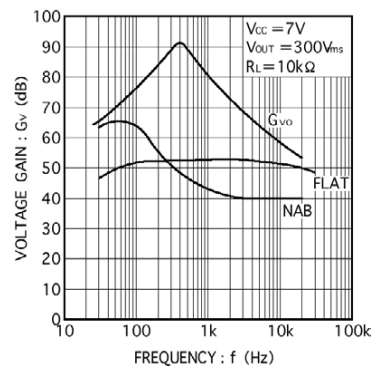

Fig.4 Voltage gain vs. frequency

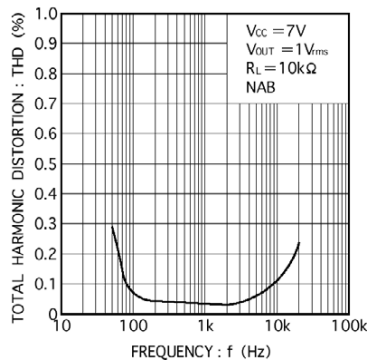

Fig.5 Total harmonic distortion vs. frequency

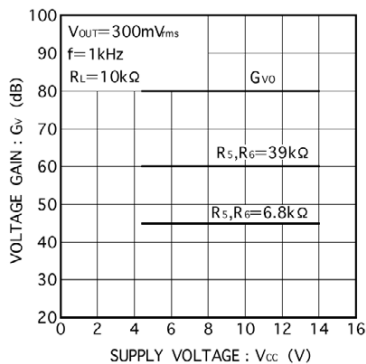

Fig.6 Voltage gain vs. supply voltage

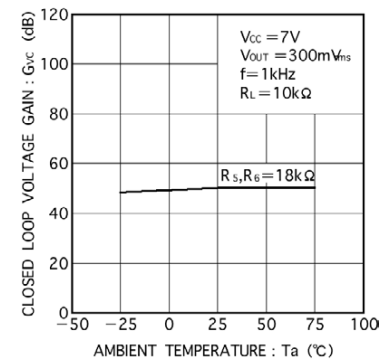

Fig.7 Closed loop voltage gain vs. ambient temperature

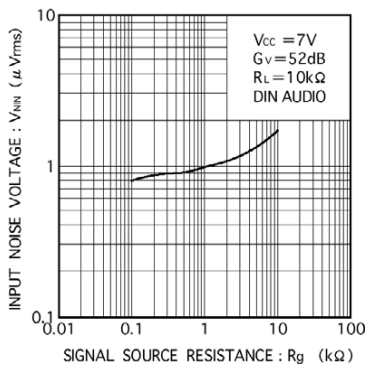

Fig.8 Input conversion noise voltage vs. signal source resistance

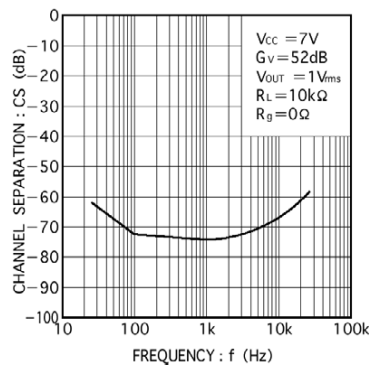

Fig.9 Channel separation vs. frequency

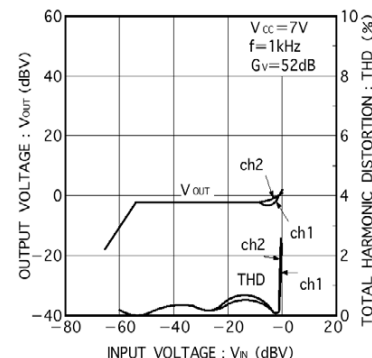

Fig.10 ALC characteristics

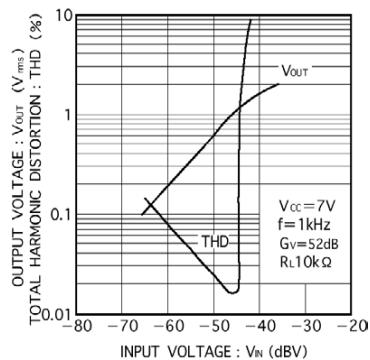

Fig.11 Input/output characteristics

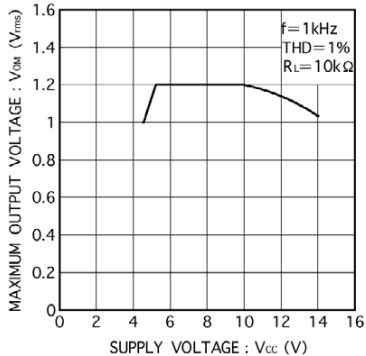

Fig.12 Maximum output voltage vs. power supply voltage

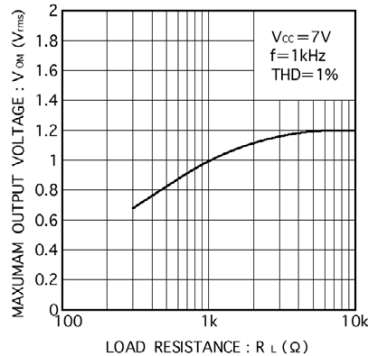

Fig.13 Maximum output voltage vs. load resistance

●Description of operations

1. Recording
 - 1) Record amplifier

The BA3308F/FV amplifier of ch1 and ch2 input stage (13pin, 9pin) can be direct coupled or use coupling capacitors (C1/C2). The voltage gain of the record amplifier is determined by $Gv=R5/R3$. The R5/R6, and C3/R3 regulate control of the pop noise that occurs at power-on (see "Cautions on use") and direct current bias fed back is set by R5/R6 and C5/C6 at the output stage.

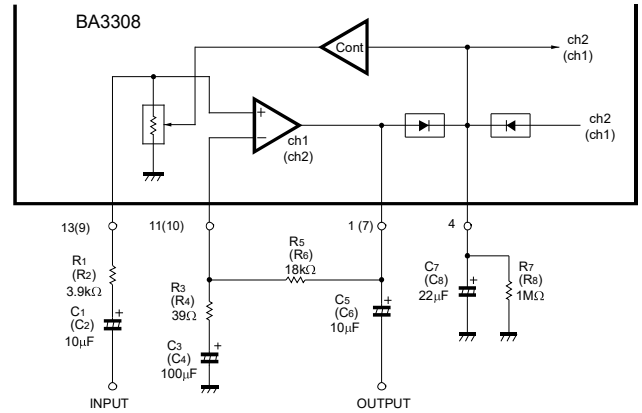

Fig.14

- 2) ALC

The BA3308F/FV has an on-chip signal rectifier and electronic volume needed for ALC. The signal rectifier compares the direct current output voltage that is superposed in the output stage (1, 7pin) signal to the reference voltage $4.5V_f$ ($\cong 3V$; $1V_f$ is approximately $0.7V$) in the comparator circuit and if the output voltage is higher, it turns the comparator ON to charge the smoothing capacitor C7. Since the operation point of the output stage of amplifier ch1 and ch2 is fixed at $3V_f$, the comparator turns ON when the peak value of the signal output voltage is $1.5V_f$ (effective value approx. $0.75V$). Once the direct current signal for electronic volume is controlled, ALC operation starts. The electronic volume, which is connected between the input line (13, 9pin) and GND, causes the input signal to attenuate according to the ratio of the external resistance (R1, R2) to the resistance value of the electronic volume. The ALC range varies according to the values of R1 and R2. For small ALC variation the S/N will determinate an adequate ALC range is obtained by applying several $k\Omega$ of the R1 and R2. The attack time and recovery time of ALC are set according to C7 and R7 of 4pin. If the time constants (C7, R7) are large, the recovery time will be long and as C7 becomes smaller, and the attack time will be shorter.

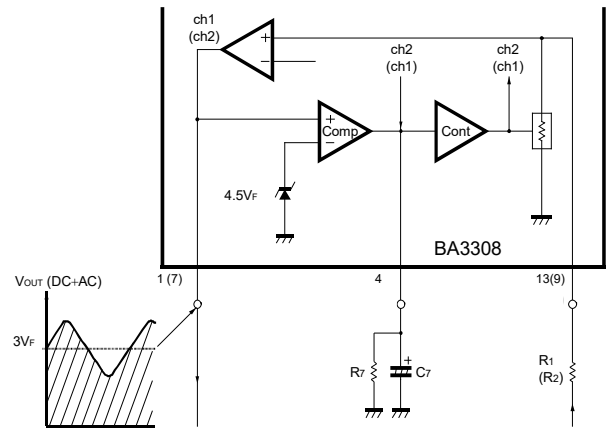

Fig.15

2. On playback

Since amplifier ch1 and ch2 are used as a NAB equalizer amplifier at playback, a time constant circuit is established in the NF section (1-11pin, 7-10pin) to obtain NAB characteristics. The voltage gain at this time is determined by the following formula:

$$G_V = |R_{11} + R_9 / (| + j\omega C_9 \cdot R_9 |) / R_3$$

Obtain the necessary gain by regulating the (power-on pop noise prevention) NAB time constant circuit in the same way when regulating the gain at recording stage. The operating point of the output stage (1,7pin) is fixed at 3VF. Accordingly, even if V_{CC} is raised to 5V or more, as in the V_{MAX} - V_{CC} characteristic (Fig.13), the maximum output voltage does not rise above 1.2V (Typ.). 4pin is grounded at playback since ALC is not needed. For better signal-to-noise ratio characteristics at playback, don't use R1 and R2, which are attached to the input pin (13pin, 9pin).

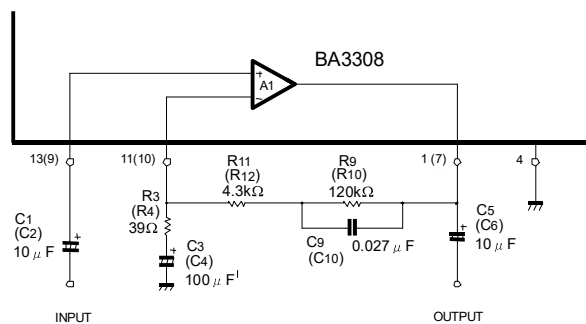

Fig.16

● Measurement circuit

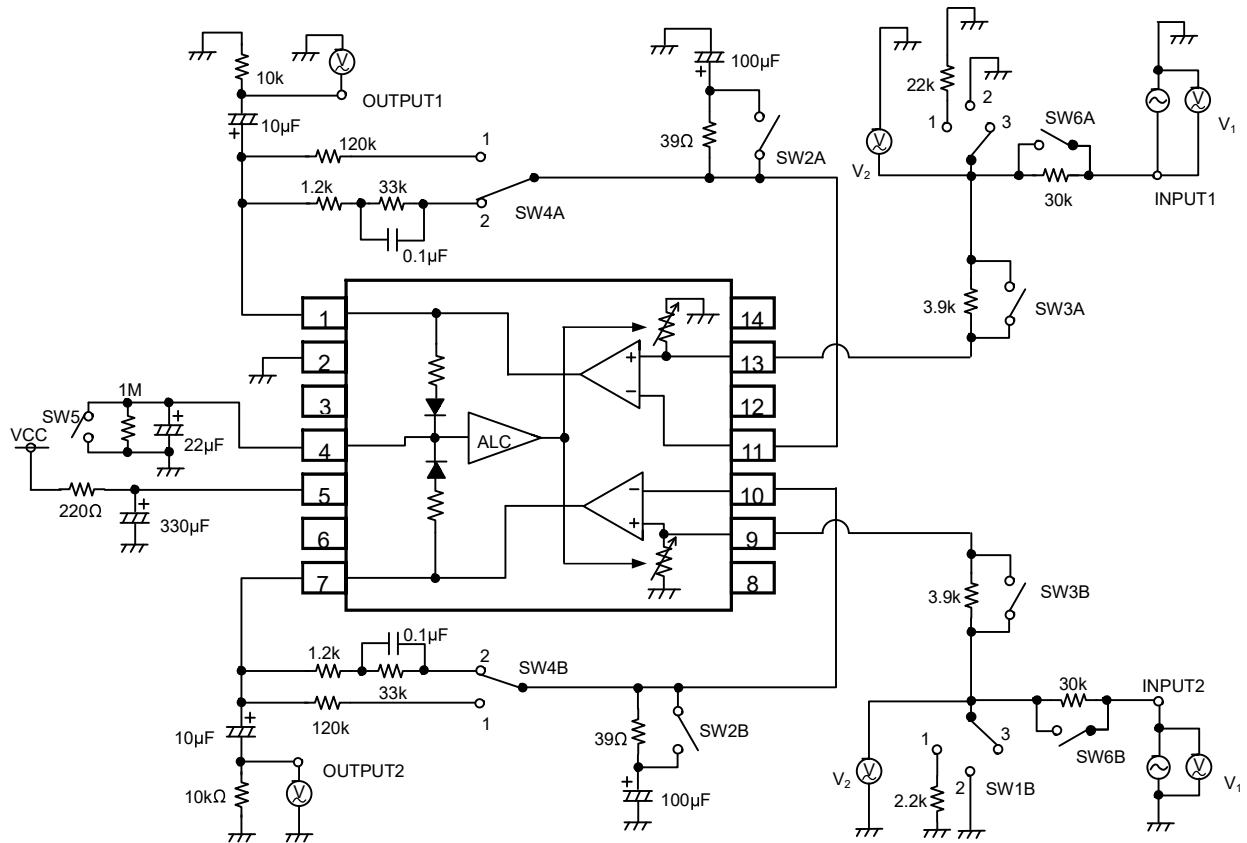
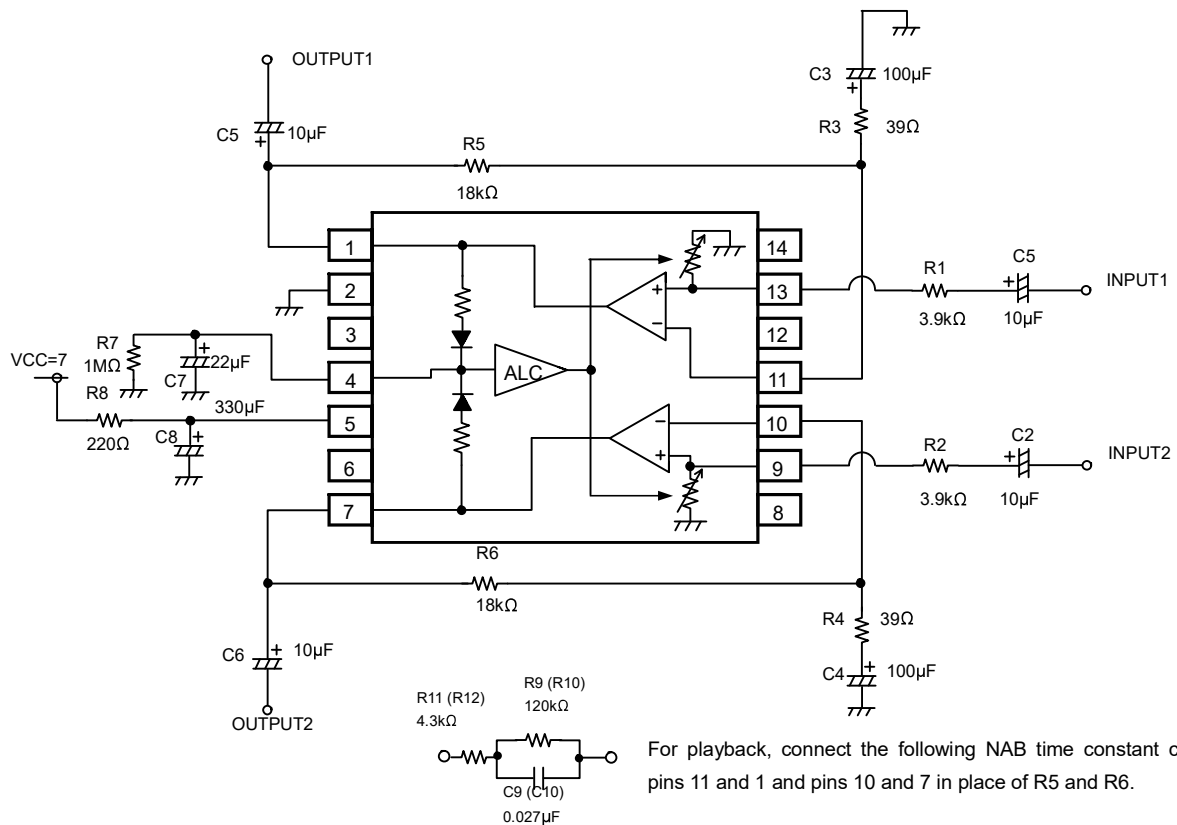

Fig.17

● Application circuit



For playback, connect the following NAB time constant circuit between pins 11 and 1 and pins 10 and 7 in place of R5 and R6.

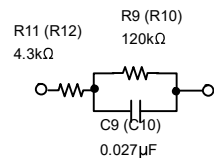
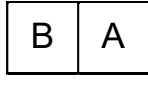

Fig.18

●Notes for use

- 1) Numbers and data in entries are representative design values and are not guaranteed values of the items.
- 2) Although ROHM is confident that the example application circuit reflects the best possible recommendations, be sure to verify circuit characteristics for your particular application. Modification of constants for other externally connected circuits may cause variations in both static and transient characteristics for external components as well as this Rohm IC. Allow for sufficient margins when determining circuit constants.
- 3) Absolute maximum ratings
Use of the IC in excess of absolute maximum ratings, such as the applied voltage or operating temperature range (Topr), may result in IC damage. Assumptions should not be made regarding the state of the IC (short mode or open mode) when such damage is suffered. A physical safety measure, such as a fuse, should be implemented when using the IC at times where the absolute maximum ratings may be exceeded.
- 4) GND potential
Ensure a minimum GND pin potential in all operating conditions. Make sure that no pins are at a voltage below the GND at any time, regardless of whether it is a transient signal or not.
- 5) Thermal design
Perform thermal design, in which there are adequate margins, by taking into account the permissible dissipation (Pd) in actual states of use.
- 6) Short circuit between terminals and erroneous mounting
Pay attention to the assembly direction of the ICs. Wrong mounting direction or shorts between terminals, GND, or other components on the circuits, can damage the IC.
- 7) Operation in strong magnetic fields
Using the ICs in a strong electromagnetic field can cause operation malfunction.
- 8) The BA3308F/FV has an on-chip power supply mute circuit that checks for pop noise at power-on. This prevents the occurrence of pop noise by timing the charge times of the direct current cut capacitors C3 and C4 of 10pin and 11pin, and of capacitor C8 for the ripple filter of 5pin.
Accordingly, to obtain an adequate effect, it is recommended that the constants of the application circuit be used in C3, C4, R3, R4, C8, and R8.

●Ordering part number



Part No.

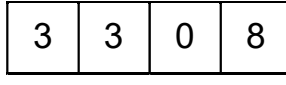

Part No.



Package
F: SOP14
FV: SSOP-B14

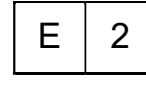

Packaging and forming specification
E2: Embossed tape and reel

SOP14

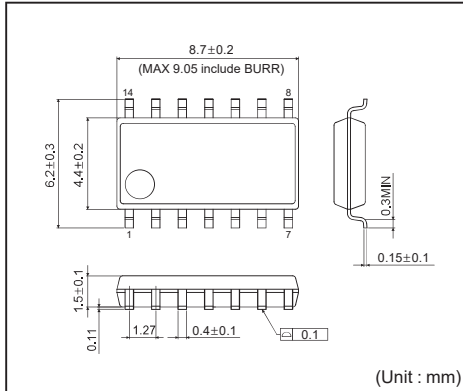

<Tape and Reel information>

Tape	Embossed carrier tape
Quantity	2500pcs
Direction of feed	E2 (The direction is the 1pin of product is at the upper left when you hold reel on the left hand and you pull out the tape on the right hand)

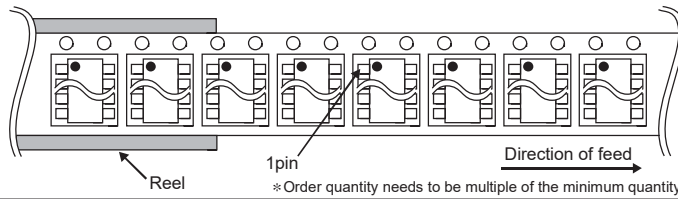

SSOP-B14

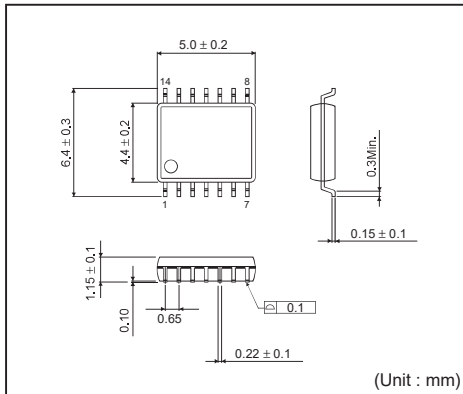

<Tape and Reel information>

Tape	Embossed carrier tape
Quantity	2500pcs
Direction of feed	E2 (The direction is the 1pin of product is at the upper left when you hold reel on the left hand and you pull out the tape on the right hand)

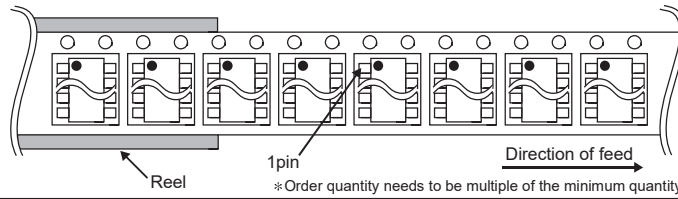

Notice

Precaution on using ROHM Products

- Our Products are designed and manufactured for application in ordinary electronic equipments (such as AV equipment, OA equipment, telecommunication equipment, home electronic appliances, amusement equipment, etc.). If you intend to use our Products in devices requiring extremely high reliability (such as medical equipment ^(Note 1), transport equipment, traffic equipment, aircraft/spacecraft, nuclear power controllers, fuel controllers, car equipment including car accessories, safety devices, etc.) and whose malfunction or failure may cause loss of human life, bodily injury or serious damage to property ("Specific Applications"), please consult with the ROHM sales representative in advance. Unless otherwise agreed in writing by ROHM in advance, ROHM shall not be in any way responsible or liable for any damages, expenses or losses incurred by you or third parties arising from the use of any ROHM's Products for Specific Applications.

(Note1) Medical Equipment Classification of the Specific Applications

JAPAN	USA	EU	CHINA
CLASS III	CLASS III	CLASS II b	CLASS III
CLASS IV		CLASS III	

- ROHM designs and manufactures its Products subject to strict quality control system. However, semiconductor products can fail or malfunction at a certain rate. Please be sure to implement, at your own responsibilities, adequate safety measures including but not limited to fail-safe design against the physical injury, damage to any property, which a failure or malfunction of our Products may cause. The following are examples of safety measures:
 - Installation of protection circuits or other protective devices to improve system safety
 - Installation of redundant circuits to reduce the impact of single or multiple circuit failure
- Our Products are designed and manufactured for use under standard conditions and not under any special or extraordinary environments or conditions, as exemplified below. Accordingly, ROHM shall not be in any way responsible or liable for any damages, expenses or losses arising from the use of any ROHM's Products under any special or extraordinary environments or conditions. If you intend to use our Products under any special or extraordinary environments or conditions (as exemplified below), your independent verification and confirmation of product performance, reliability, etc. prior to use, must be necessary:
 - Use of our Products in any types of liquid, including water, oils, chemicals, and organic solvents
 - Use of our Products outdoors or in places where the Products are exposed to direct sunlight or dust
 - Use of our Products in places where the Products are exposed to sea wind or corrosive gases, including Cl₂, H₂S, NH₃, SO₂, and NO₂
 - Use of our Products in places where the Products are exposed to static electricity or electromagnetic waves
 - Use of our Products in proximity to heat-producing components, plastic cords, or other flammable items
 - Sealing or coating our Products with resin or other coating materials
 - Use of our Products without cleaning residue of flux (even if you use no-clean type fluxes, cleaning residue of flux is recommended); or Washing our Products by using water or water-soluble cleaning agents for cleaning residue after soldering
 - Use of the Products in places subject to dew condensation
- The Products are not subject to radiation-proof design.
- Please verify and confirm characteristics of the final or mounted products in using the Products.
- In particular, if a transient load (a large amount of load applied in a short period of time, such as pulse. is applied, confirmation of performance characteristics after on-board mounting is strongly recommended. Avoid applying power exceeding normal rated power; exceeding the power rating under steady-state loading condition may negatively affect product performance and reliability.
- De-rate Power Dissipation (Pd) depending on Ambient temperature (Ta). When used in sealed area, confirm the actual ambient temperature.
- Confirm that operation temperature is within the specified range described in the product specification.
- ROHM shall not be in any way responsible or liable for failure induced under deviant condition from what is defined in this document.

Precaution for Mounting / Circuit board design

- When a highly active halogenous (chlorine, bromine, etc.) flux is used, the residue of flux may negatively affect product performance and reliability.
- In principle, the reflow soldering method must be used; if flow soldering method is preferred, please consult with the ROHM representative in advance.

For details, please refer to ROHM Mounting specification

Precautions Regarding Application Examples and External Circuits

1. If change is made to the constant of an external circuit, please allow a sufficient margin considering variations of the characteristics of the Products and external components, including transient characteristics, as well as static characteristics.
2. You agree that application notes, reference designs, and associated data and information contained in this document are presented only as guidance for Products use. Therefore, in case you use such information, you are solely responsible for it and you must exercise your own independent verification and judgment in the use of such information contained in this document. ROHM shall not be in any way responsible or liable for any damages, expenses or losses incurred by you or third parties arising from the use of such information.

Precaution for Electrostatic

This Product is electrostatic sensitive product, which may be damaged due to electrostatic discharge. Please take proper caution in your manufacturing process and storage so that voltage exceeding the Products maximum rating will not be applied to Products. Please take special care under dry condition (e.g. Grounding of human body / equipment / solder iron, isolation from charged objects, setting of Ionizer, friction prevention and temperature / humidity control).

Precaution for Storage / Transportation

1. Product performance and soldered connections may deteriorate if the Products are stored in the places where:
 - [a] the Products are exposed to sea winds or corrosive gases, including Cl₂, H₂S, NH₃, SO₂, and NO₂
 - [b] the temperature or humidity exceeds those recommended by ROHM
 - [c] the Products are exposed to direct sunshine or condensation
 - [d] the Products are exposed to high Electrostatic
2. Even under ROHM recommended storage condition, solderability of products out of recommended storage time period may be degraded. It is strongly recommended to confirm solderability before using Products of which storage time is exceeding the recommended storage time period.
3. Store / transport cartons in the correct direction, which is indicated on a carton with a symbol. Otherwise bent leads may occur due to excessive stress applied when dropping of a carton.
4. Use Products within the specified time after opening a humidity barrier bag. Baking is required before using Products of which storage time is exceeding the recommended storage time period.

Precaution for Product Label

QR code printed on ROHM Products label is for ROHM's internal use only.

Precaution for Disposition

When disposing Products please dispose them properly using an authorized industry waste company.

Precaution for Foreign Exchange and Foreign Trade act

Since our Products might fall under controlled goods prescribed by the applicable foreign exchange and foreign trade act, please consult with ROHM representative in case of export.

Precaution Regarding Intellectual Property Rights

1. All information and data including but not limited to application example contained in this document is for reference only. ROHM does not warrant that foregoing information or data will not infringe any intellectual property rights or any other rights of any third party regarding such information or data. ROHM shall not be in any way responsible or liable for infringement of any intellectual property rights or other damages arising from use of such information or data.:
2. No license, expressly or implied, is granted hereby under any intellectual property rights or other rights of ROHM or any third parties with respect to the information contained in this document.

Other Precaution



1. This document may not be reprinted or reproduced, in whole or in part, without prior written consent of ROHM.
2. The Products may not be disassembled, converted, modified, reproduced or otherwise changed without prior written consent of ROHM.
3. In no event shall you use in any way whatsoever the Products and the related technical information contained in the Products or this document for any military purposes, including but not limited to, the development of mass-destruction weapons.
4. The proper names of companies or products described in this document are trademarks or registered trademarks of ROHM, its affiliated companies or third parties.

General Precaution

1. Before you use our Products, you are requested to carefully read this document and fully understand its contents. ROHM shall not be in any way responsible or liable for failure, malfunction or accident arising from the use of any ROHM's Products against warning, caution or note contained in this document.
2. All information contained in this document is current as of the issuing date and subject to change without any prior notice. Before purchasing or using ROHM's Products, please confirm the latest information with a ROHM sales representative.
3. The information contained in this document is provided on an "as is" basis and ROHM does not warrant that all information contained in this document is accurate and/or error-free. ROHM shall not be in any way responsible or liable for any damages, expenses or losses incurred by you or third parties resulting from inaccuracy or errors of or concerning such information.

Looking for pricing, stock, or lifecycle information?

Click below to explore more details on WIN SOURCE:

-  [View BA3308FV on WIN SOURCE](#)
-  [Rohm Semiconductor Information](#)

Optimize Your Supply Chain with WIN SOURCE Solutions

-  Global Sourcing Solution
-  Obsolete Management
-  Cost Control Management
-  Shortage Management
-  Alternative Solution
-  Excess Inventory Management