



# THE DATASHEET OF DS34LV87TM/NOPB



## DS34LV87T Enhanced CMOS Quad Differential Line Driver

Check for Samples: [DS34LV87T](#)

### FEATURES

- Meets TIA/EIA-422-B (RS-422) and ITU-T V.11 Recommendation
- Interoperable With Existing 5V RS-422 Networks
- Ensured  $V_{OD}$  of 2V Min Over Operating Conditions
- Balanced Output Crossover for Low EMI (Typical Within 40 mV of 50% Voltage Level)
- Low Power Design (330  $\mu$ W @ 3.3V Static)
- ESD  $\geq$  7 kV on Cable I/O Pins (HBM)
- Industrial Temperature Range
- Ensured AC Parameter:
  - Maximum Driver Skew: 2 ns
  - Maximum Transition Time: 10 ns
- Pin Compatible With DS26C31
- Available in SOIC Packaging

### DESCRIPTION

The DS34LV87T is a high speed quad differential CMOS driver that meets the requirements of both TIA/EIA-422-B and ITU-T V.11. The CMOS DS34LV87T features low static  $I_{CC}$  of 100  $\mu$ A max which makes it ideal for battery powered and power conscious applications. The TRI-STATE enable, EN, allows the device to be disabled when the device is not in use to minimize power. The dual enable scheme allows for flexibility in turning devices on or off.

Protection diodes protect all the driver inputs against electrostatic discharge. The driver and enable inputs (DI and EN) are compatible with LVTTTL and LVCMOS devices. Differential outputs have the same  $V_{OD}$  ( $\geq$ 2V) ensure as the 5V version. The outputs have enhanced ESD Protection providing greater than 7 kV tolerance.

### Connection Diagram

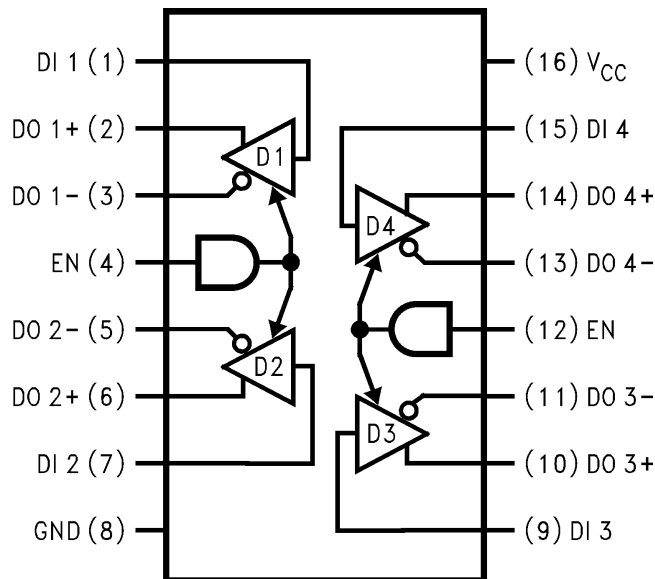

**Figure 1. Dual-In-Line Package (Top View)**  
See Package Number D0016A

### TRUTH TABLE<sup>(1)</sup>

Enables	Input	Outputs	
EN	DI	DO+	DO-
L	X	Z	Z
H	H	H	L
H	L	L	H

- (1) L = Low logic state  
X = Irrelevant  
H = High logic state  
Z = TRI-STATE



Please be aware that an important notice concerning availability, standard warranty, and use in critical applications of Texas Instruments semiconductor products and disclaimers thereto appears at the end of this data sheet.



These devices have limited built-in ESD protection. The leads should be shorted together or the device placed in conductive foam during storage or handling to prevent electrostatic damage to the MOS gates.

### ABSOLUTE MAXIMUM RATINGS<sup>(1)(2)</sup>

Supply Voltage ( $V_{CC}$ )		-0.5V to +7V
Enable Input Voltage (EN)		-0.5V to $V_{CC} + 0.5V$
Driver Input Voltage ( $D_i$ )		-0.5V to $V_{CC} + 0.5V$
Clamp Diode Current		$\pm 20$ mA
DC Output Current, per pin		$\pm 150$ mA
Driver Output Voltage	(Power Off: DO+, DO-)	-0.5V to +7V
Maximum Package Power Dissipation @+25°C	D Package	1226 mW
Derate D Package		9.8 mW/°C above +25°C
Storage Temperature Range		-65°C to +150°C
Lead Temperature Range (Soldering, 4 sec.)		+260°C
ESD Ratings (HBM, 1.5k, 100 pF)	Driver Outputs	$\geq 7$ kV
	Other Pins	$\geq 2.5$ kV

- (1) If Military/Aerospace specified devices are required, please contact the Texas Instruments Sales Office/ Distributors for availability and specifications.
- (2) Absolute Maximum Ratings are those values beyond which the safety of the device cannot be ensured. They are not meant to imply that the device should be operated at these limits. The table of [Electrical Characteristics](#) specifies conditions of device operation.

### RECOMMENDED OPERATING CONDITIONS

		Min	Typ	Max	Units
Supply Voltage ( $V_{CC}$ )		3.0	3.3	3.6	V
Operating Free Air	Temperature Range ( $T_A$ ) DS34LV87T	-40	25	+85	°C
Input Rise and Fall Time				500	ns

**ELECTRICAL CHARACTERISTICS<sup>(1)(2)</sup>**

Over Supply Voltage and Operating Temperature ranges, unless otherwise specified

Symbol	Parameter	Conditions	Pin	Min	Typ	Max	Units	
V <sub>OD1</sub>	Output Differential Voltage	R <sub>L</sub> = ∞, (No Load)	DO+, DO-		3.3	4.0	V	
V <sub>OD2</sub>	Output Differential Voltage	R <sub>L</sub> = 100Ω See <a href="#">Figure 2</a>		2	2.6		V	
ΔV <sub>OD2</sub>	Change in Magnitude of Output Differential Voltage			-400	7	400	mV	
V <sub>OD3</sub>	Output Differential Voltage	R <sub>L</sub> = 3900Ω (V.11), See <a href="#">Figure 2<sup>(3)</sup></a>			3.2	3.5	V	
V <sub>OC</sub>	Common Mode Voltage	R <sub>L</sub> = 100Ω See <a href="#">Figure 2</a>			1.5	2	V	
ΔV <sub>OC</sub>	Change in Magnitude of Common Mode Voltage			-400	6	400	mV	
I <sub>OZ</sub>	TRI-STATE Leakage Current	V <sub>OUT</sub> = V <sub>CC</sub> or GND Drivers Disabled			±0.5	±20	μA	
I <sub>SC</sub>	Output Short Circuit Current	V <sub>OUT</sub> = 0V V <sub>IN</sub> = V <sub>CC</sub> or GND <sup>(4)</sup>			-40	-70	-150	mA
I <sub>OFF</sub>	Output Leakage Current	V <sub>CC</sub> = 0V, V <sub>OUT</sub> = 3V			0.03	100	μA	
		V <sub>CC</sub> = 0V, V <sub>OUT</sub> = -0.25V			-0.08	-100	μA	
V <sub>IH</sub>	High Level Input Voltage		DI, EN	2.0		V <sub>CC</sub>	V	
V <sub>IL</sub>	Low Level Input Voltage			GND		0.8	V	
I <sub>IH</sub>	High Level Input Current	V <sub>IN</sub> = V <sub>CC</sub>				10	μA	
I <sub>IL</sub>	Low Level Input Current	V <sub>IN</sub> = GND			-10		μA	
V <sub>CL</sub>	Input Clamp Voltage	I <sub>IN</sub> = -18 mA					-1.5	V
I <sub>CC</sub>	Power Supply Current	No Load, V <sub>IN</sub> (all) = V <sub>CC</sub> or GND		V <sub>CC</sub>			100	μA

- (1) Current into device pins is defined as positive. Current out of device pins is defined as negative. All voltages are referenced to ground except differential voltages V<sub>OD1</sub>, V<sub>OD2</sub>, V<sub>OD3</sub>.
- (2) All typical values are given for V<sub>CC</sub> = 3.3V and T<sub>A</sub> = +25°C.
- (3) This specification limit is for compliance with TIA/EIA-422-B and ITU-T V.11.
- (4) Only one output shorted at a time. The output (true or complement) is configured High.

**SWITCHING CHARACTERISTICS**<sup>(1)(2)</sup>

Over Supply Voltage and Operating Temperature ranges, unless otherwise specified

Symbol	Parameter	Conditions	Min	Typ	Max	Units
t <sub>PHLD</sub>	Differential Propagation Delay High to Low	R <sub>L</sub> = 100Ω, C <sub>L</sub> = 50 pF See <a href="#">Figure 3</a> and <a href="#">Figure 4</a>	6	10.5	16	ns
t <sub>PLHD</sub>	Differential Propagation Delay Low to High		6	11	16	ns
t <sub>SKD</sub>	Differential Skew  t <sub>PHLD</sub> - t <sub>PLHD</sub>			0.5	2.0	ns
t <sub>SK1</sub>	Skew, Pin to Pin (same device)			1.0	2.0	ns
t <sub>SK2</sub>	Skew, Part to Part <sup>(3)</sup>			3.0	5.0	ns
t <sub>TLH</sub>	Differential Transition Time Low to High (20% to 80%)			4.2	10	ns
t <sub>THL</sub>	Differential Transition Time High to Low (80% to 20%)			4.7	10	ns
t <sub>PHZ</sub>	Disable Time High to Z	See <a href="#">Figure 5</a> and <a href="#">Figure 6</a>		12	20	ns
t <sub>PLZ</sub>	Disable Time Low to Z			9	20	ns
t <sub>PZH</sub>	Enable Time Z to High			22	32	ns
t <sub>PZL</sub>	Enable Time Z to Low			22	32	ns
f <sub>MAX</sub>	Maximum Operating Frequency <sup>(4)</sup>			32		MHz

(1) f = 1 MHz, t<sub>r</sub> and t<sub>f</sub> ≤ 6 ns (10% to 90%).

(2) See TIA/EIA-422-B specifications for exact test conditions.

(3) Devices are at the same V<sub>CC</sub> and within 5°C within the operating temperature range.

(4) All channels switching, output duty cycle criteria is 40%/60% measured at 50%. This parameter is ensured by design and characterization.

PARAMETER MEASUREMENT INFORMATION

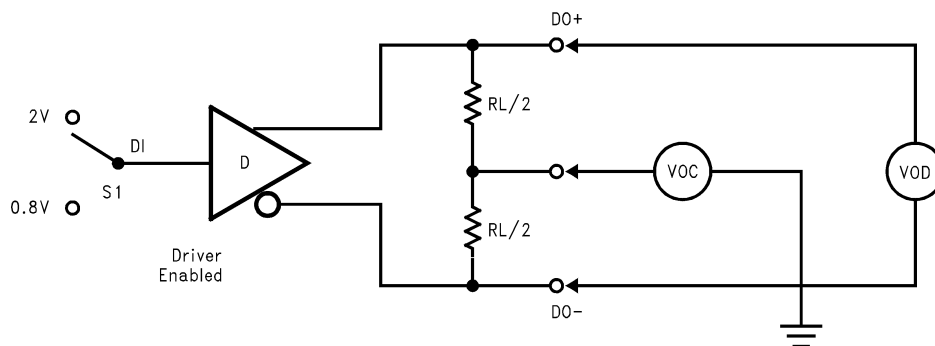

Figure 2. Differential Driver DC Test Circuit

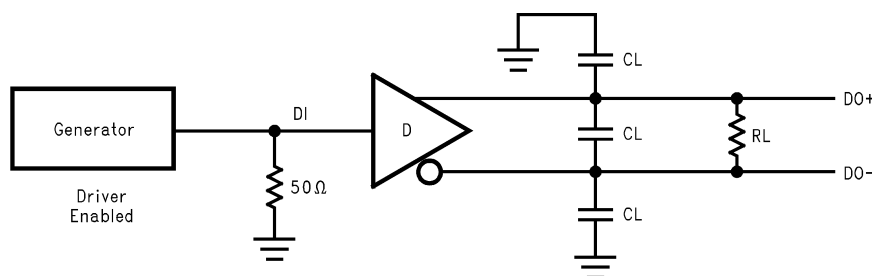
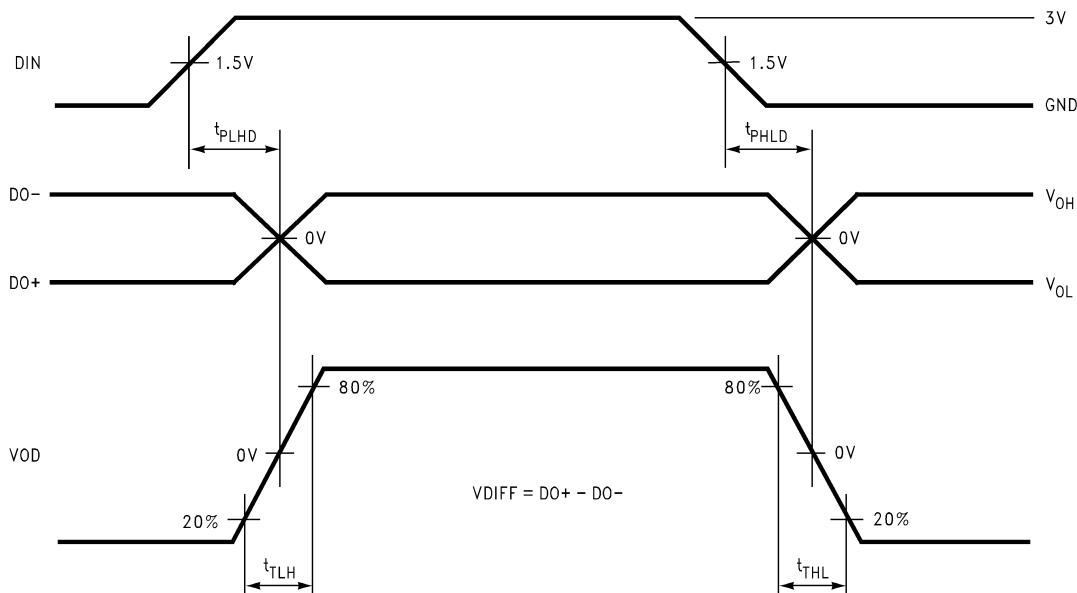

Figure 3. Differential Driver Propagation Delay and Transition Time Test Circuit



Generator waveform for all tests unless otherwise specified:  $f = 1 \text{ MHz}$ , Duty Cycle = 50%,  $Z_o = 50\Omega$ ,  $t_r \leq 10 \text{ ns}$ ,  $t_f \leq 10 \text{ ns}$ .

$C_L$  includes probe and fixture capacitance.

Figure 4. Differential Driver Propagation Delay and Transition Time Waveforms

PARAMETER MEASUREMENT INFORMATION (continued)

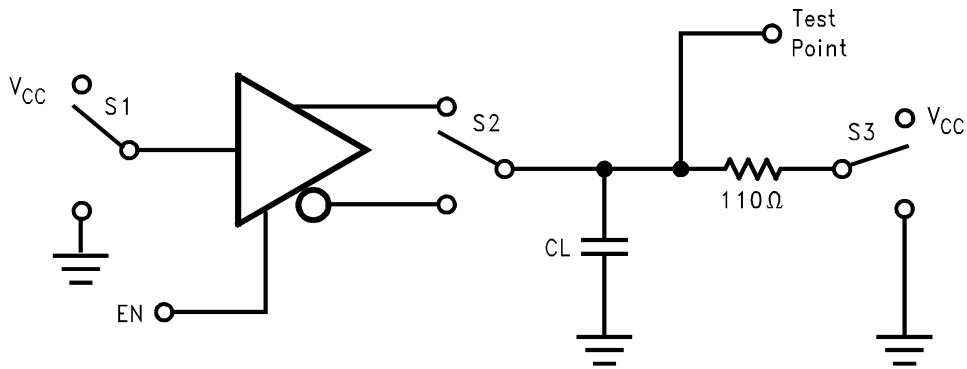

Figure 5. Driver Single-Ended Tri-state Test Circuit

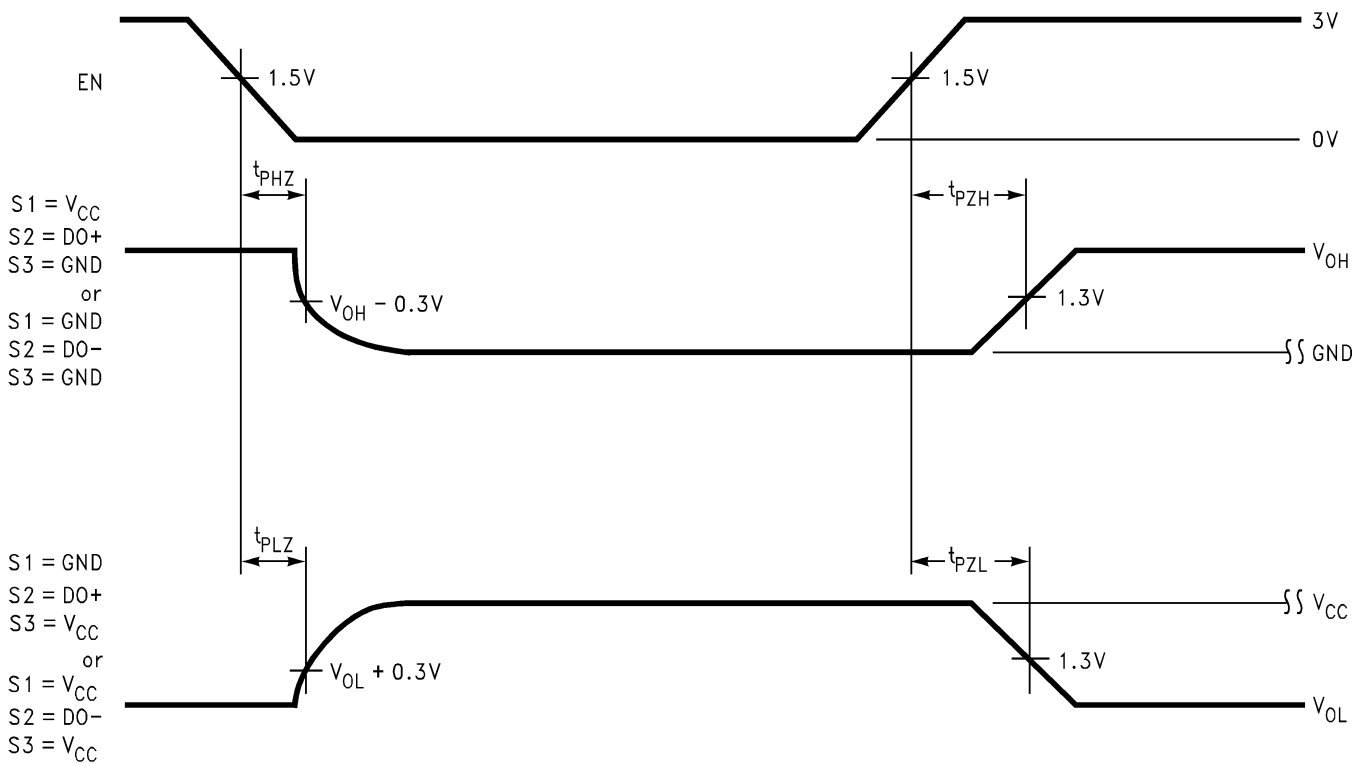

Figure 6. Driver Single-Ended Tri-state Waveforms

TYPICAL APPLICATION INFORMATION

General application guidelines and hints for differential drivers and receivers may be found in the following application notes:

- Transmission Line Drivers and Receivers for TIA/EIA Standards RS-422 and RS-423(SNLA137)
- A Comparison of Differential Termination Techniques(SNLA304)

Power Decoupling Recommendations:

Bypass caps must be used on power pins. High frequency ceramic (surface mount is recommended) 0.1  $\mu$ F in parallel with 0.01  $\mu$ F at the power supply pin. A 10  $\mu$ F or greater tantalum or electrolytic should be connected at the power entry point on the printed circuit board.

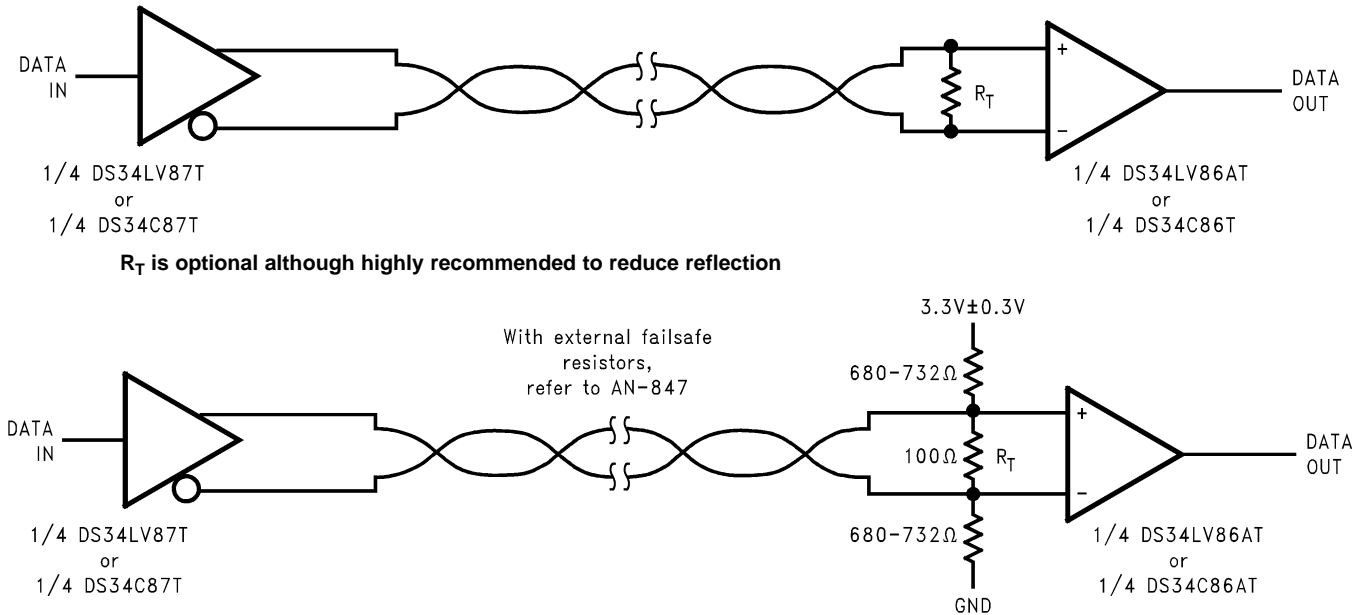

Figure 7. Typical Driver Connection

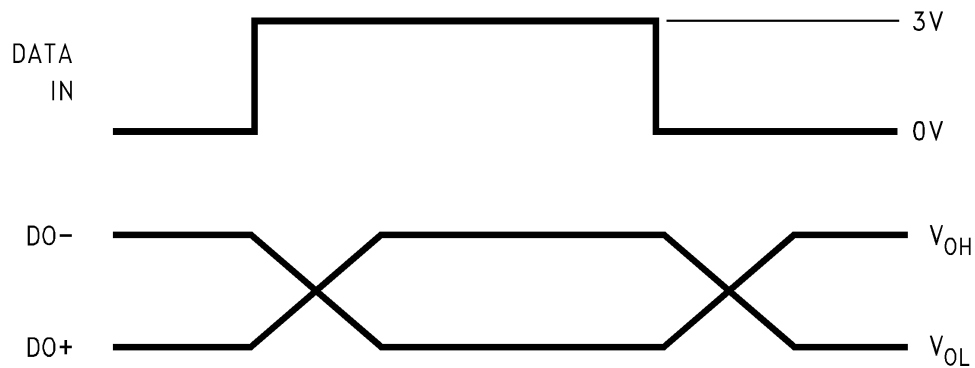



Figure 8. Typical Driver Output Waveforms

### REVISION HISTORY

Changes from Revision C (April 2013) to Revision D	Page
• Changed layout of National Data Sheet to TI format .....	<a href="#">7</a>

**PACKAGING INFORMATION**

Orderable Device	Status (1)	Package Type	Package Drawing	Pins	Package Qty	Eco Plan (2)	Lead finish/ Ball material (6)	MSL Peak Temp (3)	Op Temp (°C)	Device Marking (4/5)	Samples
DS34LV87TM/NOPB	ACTIVE	SOIC	D	16	48	RoHS & Green	SN	Level-1-260C-UNLIM	-40 to 85	DS34LV87 TM	
DS34LV87TMX/NOPB	ACTIVE	SOIC	D	16	2500	RoHS & Green	SN	Level-1-260C-UNLIM	-40 to 85	DS34LV87 TM	

(1) The marketing status values are defined as follows:

**ACTIVE:** Product device recommended for new designs.

**LIFEBUY:** TI has announced that the device will be discontinued, and a lifetime-buy period is in effect.

**NRND:** Not recommended for new designs. Device is in production to support existing customers, but TI does not recommend using this part in a new design.

**PREVIEW:** Device has been announced but is not in production. Samples may or may not be available.

**OBSOLETE:** TI has discontinued the production of the device.

(2) **RoHS:** TI defines "RoHS" to mean semiconductor products that are compliant with the current EU RoHS requirements for all 10 RoHS substances, including the requirement that RoHS substance do not exceed 0.1% by weight in homogeneous materials. Where designed to be soldered at high temperatures, "RoHS" products are suitable for use in specified lead-free processes. TI may reference these types of products as "Pb-Free".

**RoHS Exempt:** TI defines "RoHS Exempt" to mean products that contain lead but are compliant with EU RoHS pursuant to a specific EU RoHS exemption.

**Green:** TI defines "Green" to mean the content of Chlorine (Cl) and Bromine (Br) based flame retardants meet JS709B low halogen requirements of <=1000ppm threshold. Antimony trioxide based flame retardants must also meet the <=1000ppm threshold requirement.

(3) MSL, Peak Temp. - The Moisture Sensitivity Level rating according to the JEDEC industry standard classifications, and peak solder temperature.

(4) There may be additional marking, which relates to the logo, the lot trace code information, or the environmental category on the device.

(5) Multiple Device Markings will be inside parentheses. Only one Device Marking contained in parentheses and separated by a "~" will appear on a device. If a line is indented then it is a continuation of the previous line and the two combined represent the entire Device Marking for that device.

(6) Lead finish/Ball material - Orderable Devices may have multiple material finish options. Finish options are separated by a vertical ruled line. Lead finish/Ball material values may wrap to two lines if the finish value exceeds the maximum column width.

**Important Information and Disclaimer:**The information provided on this page represents TI's knowledge and belief as of the date that it is provided. TI bases its knowledge and belief on information provided by third parties, and makes no representation or warranty as to the accuracy of such information. Efforts are underway to better integrate information from third parties. TI has taken and continues to take reasonable steps to provide representative and accurate information but may not have conducted destructive testing or chemical analysis on incoming materials and chemicals. TI and TI suppliers consider certain information to be proprietary, and thus CAS numbers and other limited information may not be available for release.

In no event shall TI's liability arising out of such information exceed the total purchase price of the TI part(s) at issue in this document sold by TI to Customer on an annual basis.



**TAPE AND REEL INFORMATION**

**QUADRANT ASSIGNMENTS FOR PIN 1 ORIENTATION IN TAPE**

\*All dimensions are nominal

Device	Package Type	Package Drawing	Pins	SPQ	Reel Diameter (mm)	Reel Width W1 (mm)	A0 (mm)	B0 (mm)	K0 (mm)	P1 (mm)	W (mm)	Pin1 Quadrant
DS34LV87TMX/NOPB	SOIC	D	16	2500	330.0	16.4	6.5	10.3	2.3	8.0	16.0	Q1

**TAPE AND REEL BOX DIMENSIONS**

\*All dimensions are nominal

Device	Package Type	Package Drawing	Pins	SPQ	Length (mm)	Width (mm)	Height (mm)
DS34LV87TMX/NOPB	SOIC	D	16	2500	356.0	356.0	35.0

**TUBE**

\*All dimensions are nominal

Device	Package Name	Package Type	Pins	SPQ	L (mm)	W (mm)	T (μm)	B (mm)
DS34LV87TM/NOPB	D	SOIC	16	48	495	8	4064	3.05

D (R-PDSO-G16)

PLASTIC SMALL OUTLINE



- NOTES:
- A. All linear dimensions are in inches (millimeters).
  - B. This drawing is subject to change without notice.
  - C. Body length does not include mold flash, protrusions, or gate burrs. Mold flash, protrusions, or gate burrs shall not exceed 0.006 (0,15) each side.
  - D. Body width does not include interlead flash. Interlead flash shall not exceed 0.017 (0,43) each side.
  - E. Reference JEDEC MS-012 variation AC.

## IMPORTANT NOTICE AND DISCLAIMER

TI PROVIDES TECHNICAL AND RELIABILITY DATA (INCLUDING DATA SHEETS), DESIGN RESOURCES (INCLUDING REFERENCE DESIGNS), APPLICATION OR OTHER DESIGN ADVICE, WEB TOOLS, SAFETY INFORMATION, AND OTHER RESOURCES "AS IS" AND WITH ALL FAULTS, AND DISCLAIMS ALL WARRANTIES, EXPRESS AND IMPLIED, INCLUDING WITHOUT LIMITATION ANY IMPLIED WARRANTIES OF MERCHANTABILITY, FITNESS FOR A PARTICULAR PURPOSE OR NON-INFRINGEMENT OF THIRD PARTY INTELLECTUAL PROPERTY RIGHTS.

These resources are intended for skilled developers designing with TI products. You are solely responsible for (1) selecting the appropriate TI products for your application, (2) designing, validating and testing your application, and (3) ensuring your application meets applicable standards, and any other safety, security, regulatory or other requirements.

These resources are subject to change without notice. TI grants you permission to use these resources only for development of an application that uses the TI products described in the resource. Other reproduction and display of these resources is prohibited. No license is granted to any other TI intellectual property right or to any third party intellectual property right. TI disclaims responsibility for, and you will fully indemnify TI and its representatives against, any claims, damages, costs, losses, and liabilities arising out of your use of these resources.

TI's products are provided subject to [TI's Terms of Sale](#) or other applicable terms available either on [ti.com](http://ti.com) or provided in conjunction with such TI products. TI's provision of these resources does not expand or otherwise alter TI's applicable warranties or warranty disclaimers for TI products.

TI objects to and rejects any additional or different terms you may have proposed.

Mailing Address: Texas Instruments, Post Office Box 655303, Dallas, Texas 75265  
Copyright © 2022, Texas Instruments Incorporated

## Looking for pricing, stock, or lifecycle information?

Click below to explore more details on WIN SOURCE:

 [View DS34LV87TM/NOPB on WIN SOURCE](#)

 [Texas Instruments](#) Information

## Optimize Your Supply Chain with WIN SOURCE Solutions

-  Global Sourcing Solution
-  Obsolete Management
-  Cost Control Management
-  Shortage Management
-  Alternative Solution
-  Excess Inventory Management