



# THE DATASHEET OF AT-263-PIN



## Features

- Attenuation: 1 dB steps to 31 dB
- Temperature Stability:  
±0.18 dB from -55°C to +85°C
- Low DC Power Consumption
- Hermetic Surface Mount Package
- Integral TTL Driver
- 50 Ω Nominal Impedance
- Lead-Free CR-12 Package
- Halogen-Free “Green” Mold Compound
- RoHS\* Compliant and 260°C Reflow Compatible

## Description

The AT-263-PIN is a GaAs FET 5-bit digital attenuator with a 1 dB minimum step size and 31 dB total attenuation. This attenuator and integral TTL driver is in a hermetically sealed ceramic 16-lead surface mount package.

The AT-263-PIN is ideally suited for use where accuracy, fast switching, very low power consumption and low intermodulation products are required. Typical applications include dynamic range setting in precision receiver circuits and other gain/leveling control circuits.

Environmental screening is available. Contact the factory for information.

## Ordering Information<sup>1</sup>

Part Number	Package
AT-263-PIN	Bulk Packaging
AT-263TR	1000 piece reel
AT-263-TB	Sample Test Board

1. Reference Application Note M513 for reel size information.

## Functional Schematic

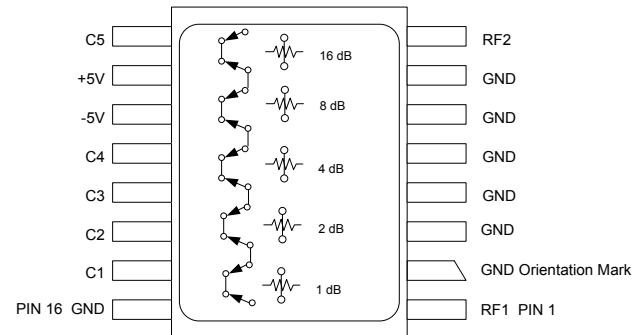

## Pin Configuration<sup>2</sup>

Pin No.	Function	Pin No.	Function
1	RF1	9	C5
2	GND	10	+5V
3	GND	11	-5V
4	GND	12	C4
5	GND	13	C3
6	GND	14	C2
7	GND	15	C1
8	RF2	16	GND

2. The exposed pad centered on the package bottom must be connected to RF, DC and thermal ground.

\* Restrictions on Hazardous Substances, European Union Directive 2011/65/EU.

## Electrical Specifications<sup>3,4</sup>: -55°C to +85°C

Parameter	Test Conditions	Units	Min.	Typ.	Max.
Insertion Loss	DC - 0.5 GHz DC - 1.0 GHz DC - 2.0 GHz	dB	—	—	2.4 2.8 3.0
Attenuation Accuracy	Any single bits DC - 1.0 GHz Any combination of bits DC - 2.0 GHz	dB	±(0.25 +3% of atten setting) ±(0.25 +3% of atten setting) or ±0.4 whichever is greater		
VSWR	Insertion Loss, DC - 2.0 GHz Attenuation States, DC - 2.0 GHz	Ratio	—	—	1.6:1 1.8:1
Switching Speed	50% Control to 90%/10% RF 10% to 90% or 90% to 10%	ns	—	40 9	—
Transients	In-Band (peak-peak)	mV	—	30	—
1 dB Compression	0.05 GHz 0.5 - 2.0 GHz	dBm	—	20 28	—
Input IP3	Two-tone inputs up to +5 dBm 0.05 GHz 0.5 - 2.0 GHz	dBm	—	40 48	—
Input IP2	Two-tone inputs up to +5 dBm 0.05 GHz 0.5 - 2.0 GHz	dBm	—	45 68	—
V <sub>CC</sub>	—	V	+4.5	+5.0	+5.5
V <sub>EE</sub>	—	V	-8.0	—	-5.0
I <sub>CC</sub>	V <sub>CC</sub> = 4.5 to 5.5 V V <sub>CONTROL</sub> = 0 to 0.8 V, or V <sub>CC</sub> -2.1 V to V <sub>CC</sub>	mA	—	—	5.0
I <sub>EE</sub>	V <sub>EE</sub> = -5 to -8 V	mA	—	—	1.0
Voltage Control	Logic 0 (TTL) Logic 1 (TTL)	V	0.0 2.0	—	0.8 5.0
Input Leakage Current	0 to 0.8 V 2 to 5 V	μA	—	—	1.0

3. All specifications apply when operated with bias voltages of +5 V for V<sub>CC</sub> and -5 V for V<sub>EE</sub>.

4. This attenuator is guaranteed monotonic.

## Absolute Maximum Ratings<sup>5,6</sup>

Parameter	Absolute Maximum
Input Power 0.05 GHz 0.5 - 2.0 GHz	27 dBm 34 dBm
$V_{CC}$	$-0.5 V \leq V_{CC} \leq +7.0 V$
$V_{EE}$	$-8.5 V \leq V_{EE} \leq +0.5 V$
$V_{CC} - V_{EE}$	$-0.5 V \leq V_{CC} - V_{EE} \leq 14.5 V$
$V_{IN}$ <sup>7</sup>	$-0.5 V \leq V_{IN} \leq V_{CC} + 0.5 V$
Operating Temperature	$-55^{\circ}C$ to $+125^{\circ}C$
Storage Temperature	$-65^{\circ}C$ to $+150^{\circ}C$

- Exceeding any one or combination of these limits may cause permanent damage to this device.
- MACOM does not recommend sustained operation near these survivability limits.
- Standard CMOS TTL interface, latch-up will occur if logic signal is applied prior to power supply.

## Truth Table<sup>8</sup>

Control Inputs					
C5	C4	C3	C2	C1	Attenuation
0	0	0	0	0	Reference
0	0	0	0	1	1 dB
0	0	0	1	0	2 dB
0	0	1	0	0	4 dB
0	1	0	0	0	8 dB
1	0	0	0	0	16 dB
1	1	1	1	1	31 dB

8. 0 = TTL Low; 1 = TTL High

## Handling Procedures

Please observe the following precautions to avoid damage:

## Static Sensitivity

These electronic devices are sensitive to electrostatic discharge (ESD) and can be damaged by static electricity. Proper ESD control techniques should be used when handling these devices.

## Recommended PCB Configuration

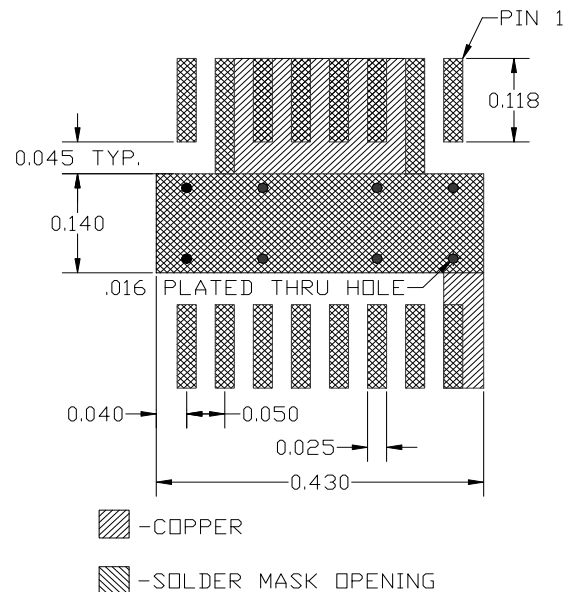

TYPICAL METAL/SOLDER MASK LAYOUT FOR CR-12 PACKAGE

## Typical Performance Curves

Ref. Insertion Loss vs. Frequency

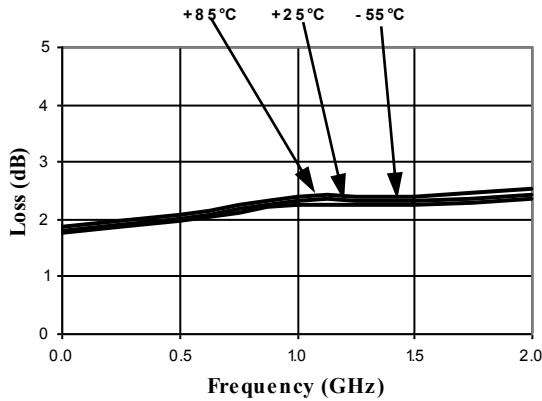

Attenuation Accuracy vs. Frequency

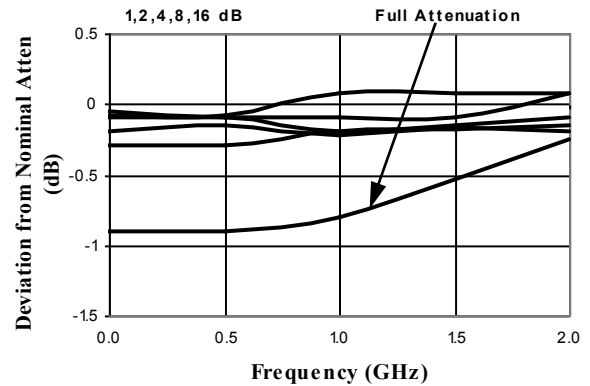

VSWR vs. Frequency

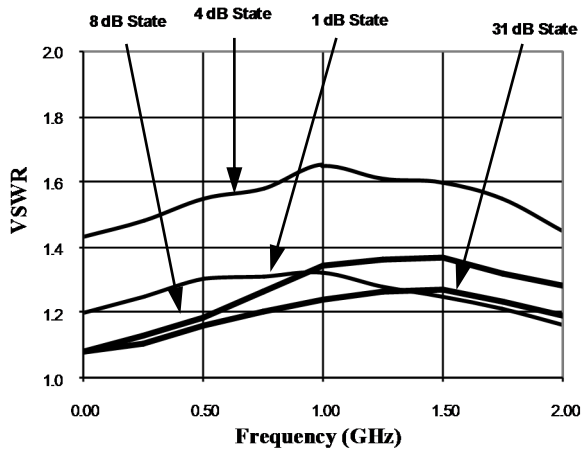

Lead-Free, CR-12 Ceramic Package†

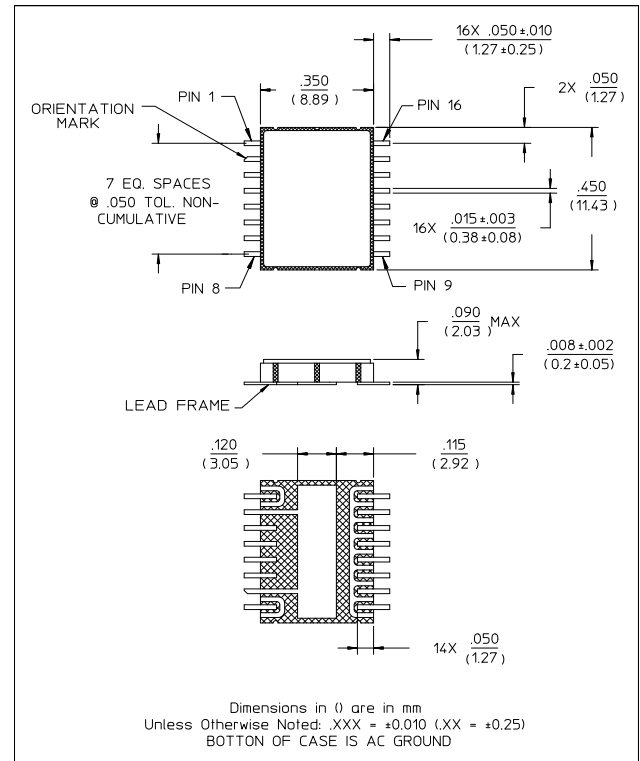

† Reference Application Note M538 for lead-free solder reflow recommendations.

M/A-COM Technology Solutions Inc. All rights reserved.

Information in this document is provided in connection with M/A-COM Technology Solutions Inc ("MACOM") products. These materials are provided by MACOM as a service to its customers and may be used for informational purposes only. Except as provided in MACOM's Terms and Conditions of Sale for such products or in any separate agreement related to this document, MACOM assumes no liability whatsoever. MACOM assumes no responsibility for errors or omissions in these materials. MACOM may make changes to specifications and product descriptions at any time, without notice. MACOM makes no commitment to update the information and shall have no responsibility whatsoever for conflicts or incompatibilities arising from future changes to its specifications and product descriptions. No license, express or implied, by estoppel or otherwise, to any intellectual property rights is granted by this document.

THESE MATERIALS ARE PROVIDED "AS IS" WITHOUT WARRANTY OF ANY KIND, EITHER EXPRESS OR IMPLIED, RELATING TO SALE AND/OR USE OF MACOM PRODUCTS INCLUDING LIABILITY OR WARRANTIES RELATING TO FITNESS FOR A PARTICULAR PURPOSE, CONSEQUENTIAL OR INCIDENTAL DAMAGES, MERCHANTABILITY, OR INFRINGEMENT OF ANY PATENT, COPYRIGHT OR OTHER INTELLECTUAL PROPERTY RIGHT. MACOM FURTHER DOES NOT WARRANT THE ACCURACY OR COMPLETENESS OF THE INFORMATION, TEXT, GRAPHICS OR OTHER ITEMS CONTAINED WITHIN THESE MATERIALS. MACOM SHALL NOT BE LIABLE FOR ANY SPECIAL, INDIRECT, INCIDENTAL, OR CONSEQUENTIAL DAMAGES, INCLUDING WITHOUT LIMITATION, LOST REVENUES OR LOST PROFITS, WHICH MAY RESULT FROM THE USE OF THESE MATERIALS.

MACOM products are not intended for use in medical, lifesaving or life sustaining applications. MACOM customers using or selling MACOM products for use in such applications do so at their own risk and agree to fully indemnify MACOM for any damages resulting from such improper use or sale.

## Looking for pricing, stock, or lifecycle information?

Click below to explore more details on WIN SOURCE:

- ⊖ [View AT-263-PIN](#) on WIN SOURCE
- ⊖ [M/A-Com Technology Solutions](#) Information

## Optimize Your Supply Chain with WIN SOURCE Solutions

- ✓ Global Sourcing Solution
- ✓ Obsolete Management
- ✓ Cost Control Management
- ✓ Shortage Management
- ✓ Alternative Solution
- ✓ Excess Inventory Management