



# THE DATASHEET OF TMP20AIDCKT



## TMP20 $\pm 2.5^{\circ}\text{C}$ Low-Power, Analog Out Temperature Sensor

### 1 Features

- $\pm 2.5^{\circ}\text{C}$  Accuracy from  $-55^{\circ}\text{C}$  to  $+130^{\circ}\text{C}$
- Supply Voltage Range: 1.8 V to 5.5 V
- Low Power: 4  $\mu\text{A}$  (Maximum)
- *MicroSize* Packages: SOT-563, SC70-5
- SC70 Pin-Compatible With LM20

### 2 Applications

- Cell Phones
- Desktop and Notebook Computers
- Portable Devices
- Consumer Electronics
- Battery Management
- Power Supplies
- HVAC
- Thermal Monitoring
- Disk Drives
- Appliances and White Goods
- Automotive

### 3 Description

The TMP20 device is a CMOS, precision analog output temperature sensor available in the tiny SOT-563 package. The TMP20 operates from  $-55^{\circ}\text{C}$  to  $+130^{\circ}\text{C}$  on a supply voltage of 2.7 V to 5.5 V with a supply current of 4  $\mu\text{A}$ . Operation as low as 1.8 V is possible for temperatures between  $15^{\circ}\text{C}$  and  $130^{\circ}\text{C}$ . The linear transfer function has a slope of  $-11.77$  mV/ $^{\circ}\text{C}$  (typical) and an output voltage of 1.8639 V (typical) at  $0^{\circ}\text{C}$ . The TMP20 has a  $\pm 2.5^{\circ}\text{C}$  accuracy across the entire specified temperature range of  $-55^{\circ}\text{C}$  to  $+130^{\circ}\text{C}$ .

The 4- $\mu\text{A}$  (maximum) supply current of the TMP20 limits self-heating of the device to less than  $0.01^{\circ}\text{C}$ . When  $V_{+}$  is less than 0.5 V, the device is in shutdown mode and consumes less than 20 nA (typical).

The TMP20 is available in a 5-lead SC70 or 6-lead SOT-563 package that reduces the overall required board space.

#### Device Information<sup>(1)</sup>

PART NUMBER	PACKAGE	BODY SIZE (NOM)
TMP20	SOT-563 (6)	1.60 mm x 1.20 mm
	SC70 (5)	2.00 mm x 1.25 mm

(1) For all available packages, see the orderable addendum at the end of the data sheet.

#### Device Block Diagram

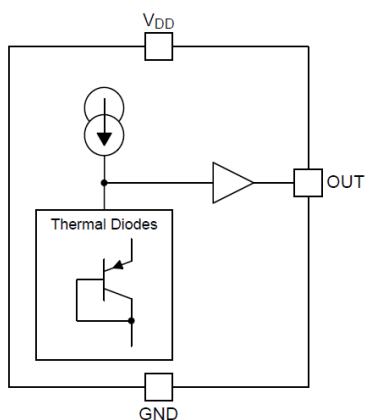

#### Device Quiescent Current Over Temperature

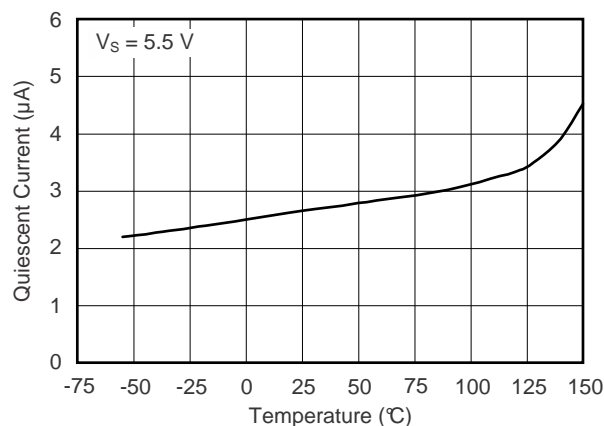



## 5 Pin Configuration and Functions

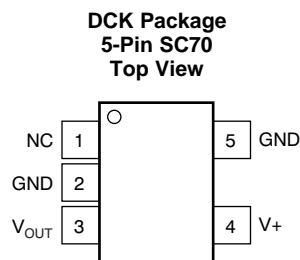
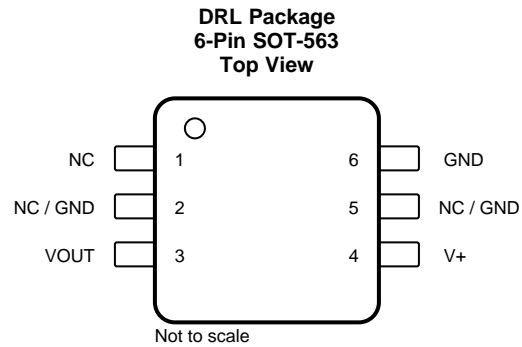

NC- no internal connection

### Pin Functions

NAME	PIN		I/O	DESCRIPTION
	DRL (SOT-563)	DCK (SC70)		
GND	6	5	—	Ground pin
NC	1	1	—	This pin must be grounded or left floating. See <a href="#">Layout Example</a> for more information.
NC / GND	2, 5	2	—	This pin must be grounded or left floating. For best thermal response, connect to GND plane. See <a href="#">Layout Example</a> for more information.
V <sub>OUT</sub>	3	3	O	Analog output
V+	4	4	I	Positive supply voltage

## 6 Specifications

### 6.1 Absolute Maximum Ratings

over operating free-air temperature range (unless otherwise noted)<sup>(1)</sup>

	MIN	MAX	UNIT
Supply voltage, V+		7	V
Operating temperature	–55	150	°C
Junction temperature, T <sub>J(max)</sub>		150	°C
Storage temperature, T <sub>stg</sub>	–65	150	°C

- (1) Stresses beyond those listed under *Absolute Maximum Ratings* may cause permanent damage to the device. These are stress ratings only, which do not imply functional operation of the device at these or any other conditions beyond those indicated under *Recommended Operating Conditions*. Exposure to absolute-maximum-rated conditions for extended periods may affect device reliability.

### 6.2 ESD Ratings

		VALUE	UNIT
V <sub>(ESD)</sub> Electrostatic discharge	Human-body model (HBM), per ANSI/ESDA/JEDEC JS-001 <sup>(1)</sup>	±4000	V
	Charged-device model (CDM), per JEDEC specification JESD22-C101 <sup>(2)</sup>	±1000	
	Machine model (MM)	±200	

- (1) JEDEC document JEP155 states that 500-V HBM allows safe manufacturing with a standard ESD control process.

- (2) JEDEC document JEP157 states that 250-V CDM allows safe manufacturing with a standard ESD control process.

### 6.3 Recommended Operating Conditions

over operating free-air temperature range (unless otherwise noted)

		MIN	MAX	UNIT
V <sub>DD</sub>	Supply voltage range	1.8	5.5	V
T <sub>A</sub>	Specified temperature range	–55	130	°C

### 6.4 Thermal Information

THERMAL METRIC <sup>(1)</sup>		TMP20		UNIT
		DRL (SOT563)	DCK (SC70)	
		6 PINS	5 PINS	
R <sub>θJA</sub>	Junction-to-ambient thermal resistance	238	185	°C/W
R <sub>θJC(top)</sub>	Junction-to-case (top) thermal resistance	253	263.3	°C/W
R <sub>θJB</sub>	Junction-to-board thermal resistance	126.4	76.2	°C/W
ψ <sub>JT</sub>	Junction-to-top characterization parameter	126	51.3	°C/W
ψ <sub>JB</sub>	Junction-to-board characterization parameter	13	1.1	°C/W
R <sub>θJC(bot)</sub>	Junction-to-case (bottom) thermal resistance	125.9	50.6	°C/W

- (1) For more information about traditional and new thermal metrics, see the [Semiconductor and IC Package Thermal Metrics](#) application report.

## 6.5 Electrical Characteristics

over operating free-air temperature range (unless otherwise noted)

PARAMETER		TEST CONDITIONS	MIN	TYP	MAX	UNIT
<b>TEMPERATURE MEASUREMENT <sup>(1)</sup></b>						
	Accuracy <sup>(2)</sup>	$T_A = -55^{\circ}\text{C}$ to $130^{\circ}\text{C}$	-2.5		2.5	$^{\circ}\text{C}$
	vs supply	$V_+ = 1.8\text{ V}$ to $5.5\text{ V}$ $T_A = 15^{\circ}\text{C}$ to $130^{\circ}\text{C}$	-0.05		0.05	$^{\circ}\text{C}/\text{V}$
		$V_+ = 2.7\text{ V}$ to $5.5\text{ V}$ $T_A = -50^{\circ}\text{C}$ to $130^{\circ}\text{C}$	-0.05		0.05	$^{\circ}\text{C}/\text{V}$
	Temperature sensitivity <sup>(3)</sup>	$T_A = -30^{\circ}\text{C}$ to $100^{\circ}\text{C}$	-12.2	-11.77	-11.4	$\text{mV}/^{\circ}\text{C}$
	Output voltage <sup>(4)</sup>	$T_A = 0^{\circ}\text{C}$		1863.9		mV
		$T_A = 25^{\circ}\text{C}$		1574		
	Nonlinearity <sup>(5)</sup>	$-20^{\circ}\text{C} \leq T_A \leq 80^{\circ}\text{C}$		$\pm 0.4\%$		
<b>ANALOG OUTPUT</b>						
	Output resistance	$-600\ \mu\text{A} \leq I_{\text{LOAD}} \leq 600\ \mu\text{A}$		10		$\Omega$
	Load regulation	$-600\ \mu\text{A} \leq I_{\text{LOAD}} \leq 600\ \mu\text{A}$		6		mV
	Maximum capacitive load		1			nF
<b>POWER SUPPLY</b>						
$V_S$	Specified voltage	$T_A = -55^{\circ}\text{C}$ to $130^{\circ}\text{C}$	2.7		5.5	V
		$T_A = 15^{\circ}\text{C}$ to $130^{\circ}\text{C}$ <sup>(6)</sup>	1.8		5.5	
$I_Q$	Quiescent current	$V_+ = 5.5\text{ V}$ $T_A = 25^{\circ}\text{C}$		2.6	4	$\mu\text{A}$
	Over temperature	$V_+ = 5.5\text{ V}$ $T_A = -55^{\circ}\text{C}$ to $130^{\circ}\text{C}$			6	$\mu\text{A}$
$I_{SD}$	Shutdown current	$V_+ < 0.5\text{ V}$		20		nA
<b>TEMPERATURE RANGE</b>						
	Specified operating	$T_A = -55^{\circ}\text{C}$ to $130^{\circ}\text{C}$	-55		130	$^{\circ}\text{C}$
		$T_A = 15^{\circ}\text{C}$ to $130^{\circ}\text{C}$ <sup>(6)</sup>	15		130	$^{\circ}\text{C}$
	Operating range	$V_+ = 2.7\text{ V}$ to $5.5\text{ V}$	-55		150	$^{\circ}\text{C}$
$\theta_{JA}$	Thermal resistance	SC70		185		$^{\circ}\text{C}/\text{W}$
		SOT-563		238		$^{\circ}\text{C}/\text{W}$
	Self-heating	SC70			0.01	$^{\circ}\text{C}$
		SOT-563			0.01	$^{\circ}\text{C}$

(1) 100% production tested at  $T_A = 25^{\circ}\text{C}$ . Specifications over temperature range are assured by design.

(2) Power-supply rejection is encompassed in the accuracy specification.

(3) Temperature sensitivity is the average slope to the equation  $V_O = (-11.77 \times T) + 1.860\text{ V}$ .

(4)  $V_{\text{OUT}}$  is calculated from temperature with the following equation:

$$V_O = (-3.88 \times 10^{-6} \times T^2) + (-1.15 \times 10^{-2} \times T) + 1.8639\text{ V},$$

where T is in  $^{\circ}\text{C}$ .

(5) Nonlinearity is the deviation of the calculated output voltage from the best fit straight line.

(6) The TMP20 transfer function requires the output voltage to rise above the 1.8-V supply as the temperature decreases below  $15^{\circ}\text{C}$ . When operating at a 1.8-V supply, it is normal for the TMP20 output to approach 1.8 V and remain at that voltage as the temperature continues to decrease below  $15^{\circ}\text{C}$ . This condition does not damage the device. Once the temperature rises above  $15^{\circ}\text{C}$ , the output voltage resumes changing as the temperature changes, according to the transfer function specified in this document. For more information about the transfer function, see [Transfer Function](#).

## 6.6 Typical Characteristics

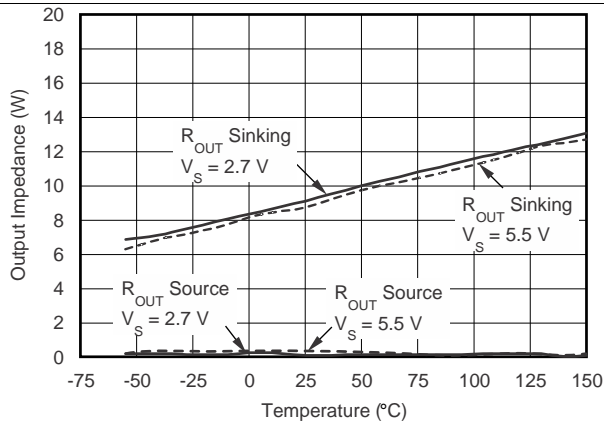

Figure 1. Output Impedance vs Temperature

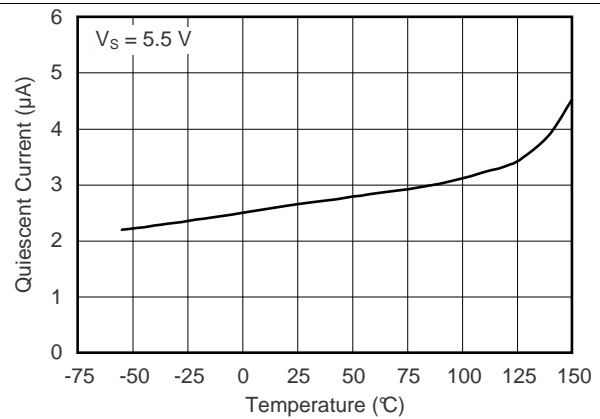

Figure 2. Quiescent Current vs Temperature

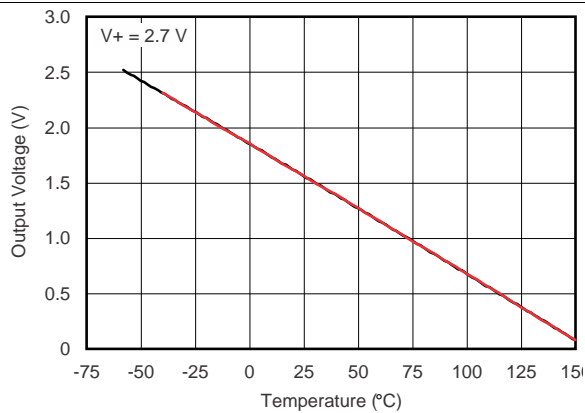

Figure 3. Output Voltage vs Temperature

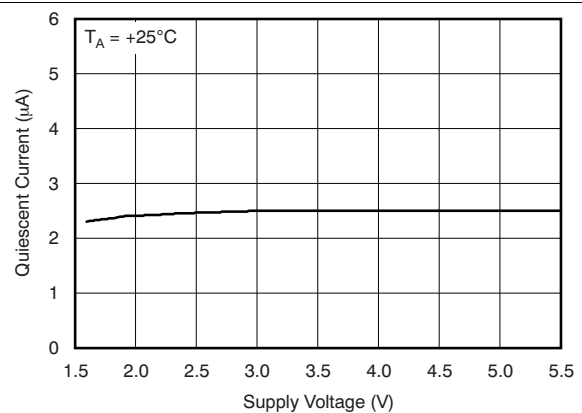

Figure 4. Quiescent Current vs Supply Voltage

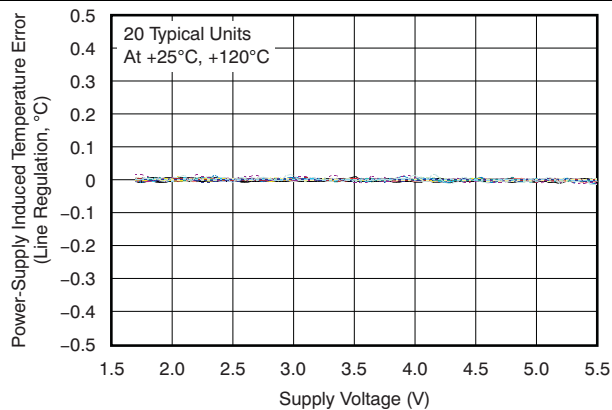

Figure 5. Power-Supply Rejection vs Temperature

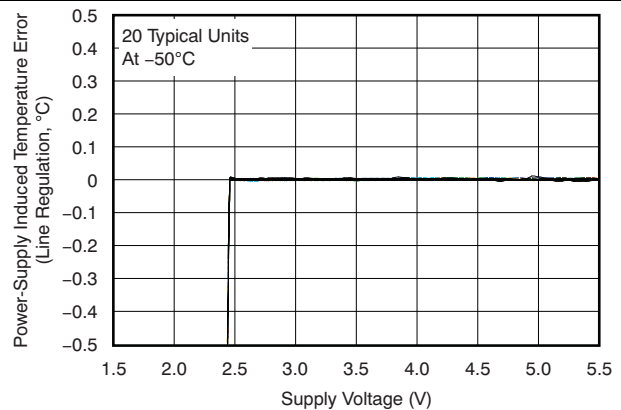
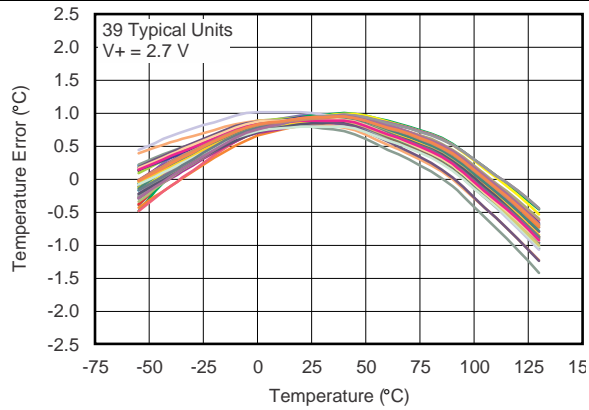
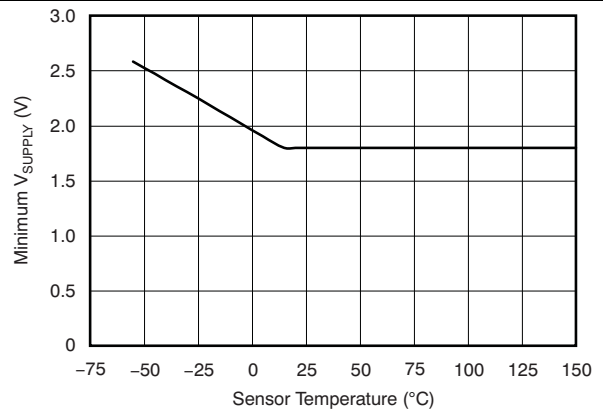

Figure 6. Power-Supply Rejection vs Temperature

**Typical Characteristics (continued)**



**Figure 7. Temperature Error vs Temperature**



**Figure 8. Minimum Supply Voltage vs Temperature**

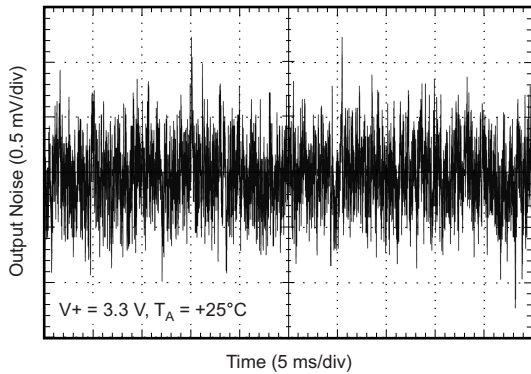

**Figure 9. Wideband Output Noise Voltage**

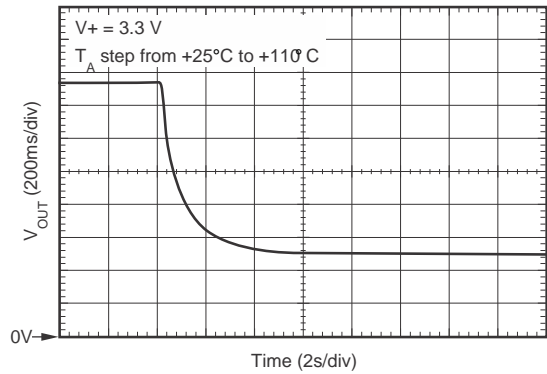

**Figure 10. Thermal Settling (Fluid-Filled Temperature Bath)**

## 7 Detailed Description

### 7.1 Overview

The TMP20 device is a precision analog output temperature sensor. The temperature range of operation is  $-55^{\circ}\text{C}$  to  $+130^{\circ}\text{C}$  with supply voltages of 2.7 V to 5.5 V. The TMP20 operates from power-supply voltages as low as 1.8 V over a temperature range of  $15^{\circ}\text{C}$  to  $130^{\circ}\text{C}$ .

TI recommends power supply bypassing; use a 100-nF capacitor placed as closely as possible to the supply pin.

### 7.2 Functional Block Diagram

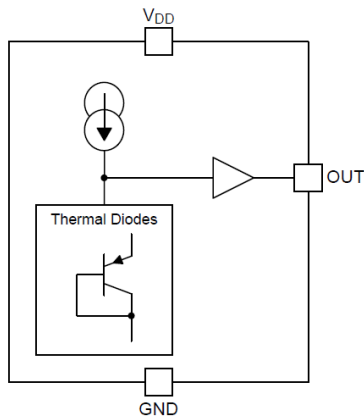

## 7.3 Feature Description

### 7.3.1 Transfer Function

The analog output of the TMP20 over the  $-55^{\circ}\text{C}$  to  $+130^{\circ}\text{C}$  temperature range corresponds to the parabolic transfer function shown in

[Added Receiving Notification of Documentation Updates section:](#)

$$V_{\text{OUT}} = \left(-3.88 \times 10^{-6} \times T^2\right) + \left(-1.15 \times 10^{-2} \times T\right) + 1.8639 \text{ V}$$

Where:

- the temperature (T) is in  $^{\circ}\text{C}$ . (1)

When solving for temperature, the equation is shown as [Equation 2:](#)

$$T = -1481.96 + \sqrt{2.1962 \times 10^6 + \frac{(1.8639 - V_{\text{O}})}{3.88 \times 10^{-6}}}$$
 (2)

These equations apply over the entire operating range of  $-55^{\circ}\text{C}$  to  $+130^{\circ}\text{C}$ .

A simplified linear transfer function referenced at  $25^{\circ}\text{C}$  is shown in [Equation 3:](#)

$$V_{\text{OUT}} = -11.69 \text{ mV}/^{\circ}\text{C} \times T + 1.8863 \text{ V}$$
 (3)

Linear transfer functions are calculated for limited temperature ranges by calculating the slope and offset for that limited range, where slope is calculated by [Equation 4:](#)

$$m = -7.76 \times 10^{-6} \times T - 0.0115$$

Where:

- T equals the temperature at the middle of the temperature range of interest (4)

The offset in the linear transfer function is calculated with [Equation 5:](#)

$$b = \left(V_{\text{OUT}}(T_{\text{MAX}}) + V_{\text{OUT}}(T) - m \times (T_{\text{MAX}} + T)\right) / 2$$

where

- $V_{\text{OUT}}(T_{\text{MAX}})$  is the calculated output voltage at  $T_{\text{MAX}}$  as determined from [Added Receiving Notification of Documentation Updates section.](#) (5)

$V_{\text{OUT}}(T)$  is the calculated output voltage at T as calculated by [Added Receiving Notification of Documentation Updates section.](#)

#### 7.3.1.1 Example 1

Determine the linear transfer function for  $-40^{\circ}\text{C}$  to  $+110^{\circ}\text{C}$ .

$T_{\text{MIN}} = -40^{\circ}\text{C}$ ;  $T_{\text{MAX}} = 110^{\circ}\text{C}$ ; therefore,  $T = 35^{\circ}\text{C}$

$$m = -11.77 \text{ mV}/^{\circ}\text{C}$$

$$V_{\text{OUT}}(110^{\circ}\text{C}) = 0.5520 \text{ V}$$

$$V_{\text{OUT}}(35^{\circ}\text{C}) = 1.4566 \text{ V}$$

$$b = 1.8576 \text{ V}$$

The linear transfer function for  $-40^{\circ}\text{C}$  to  $+110^{\circ}\text{C}$  is shown in [Equation 6:](#)

$$V_{\text{OUT}} = -11.77 \text{ mV}/^{\circ}\text{C} \times T + 1.8576 \text{ V}$$
 (6)

## Feature Description (continued)

Table 1 lists common temperature ranges of interest and the corresponding linear transfer functions for these ranges. Note that the error (maximum deviation) of the linear equation from the parabolic equation increases as the temperature ranges widen.

**Table 1. Common Temperature Ranges and Corresponding Linear Transfer Functions**

TEMPERATURE RANGE		LINEAR EQUATION (V)	MAXIMUM DEVIATION OF LINEAR EQUATION FROM PARABOLIC EQUATION (°C)
T <sub>MIN</sub> (°C)	T <sub>MAX</sub> (°C)		
-55	130	$V_{OUT} = -11.79 \text{ mV/}^\circ\text{C} \times T + 1.8528$	±1.41
-40	110	$V_{OUT} = -11.77 \text{ mV/}^\circ\text{C} \times T + 1.8577$	±0.93
-30	100	$V_{OUT} = -11.77 \text{ mV/}^\circ\text{C} \times T + 1.8605$	±0.70
-40	85	$V_{OUT} = -11.67 \text{ mV/}^\circ\text{C} \times T + 1.8583$	±0.65
-10	65	$V_{OUT} = -11.71 \text{ mV/}^\circ\text{C} \times T + 1.8641$	±0.23
35	45	$V_{OUT} = -11.81 \text{ mV/}^\circ\text{C} \times T + 1.8701$	±0.004
20	30	$V_{OUT} = -11.69 \text{ mV/}^\circ\text{C} \times T + 1.8663$	±0.004

## 7.4 Device Functional Modes

The singular functional mode of the TMP20 is an analog output inversely proportional to temperature.

## 8 Application and Implementation

### NOTE

Information in the following applications sections is not part of the TI component specification, and TI does not warrant its accuracy or completeness. TI's customers are responsible for determining suitability of components for their purposes. Customers should validate and test their design implementation to confirm system functionality.

### 8.1 Application Information

#### 8.1.1 Output Drive and Capacitive Loads

When used in noisy environments, adding a capacitor from the output to ground with a series resistor filters the TMP20 output; this configuration is shown in [Figure 11](#). The TMP20 can drive up to 1 nF of load capacitance while sourcing and sinking 600  $\mu$ A. Under this condition, capacitive loads in the range of 1 nF to 10  $\mu$ F require a 150- $\Omega$  series output resistor to achieve a stable temperature measurement. The output impedance of the TMP20 is typically 10  $\Omega$  when sinking currents and less than 1  $\Omega$  when sourcing current, as shown in [Figure 1](#).

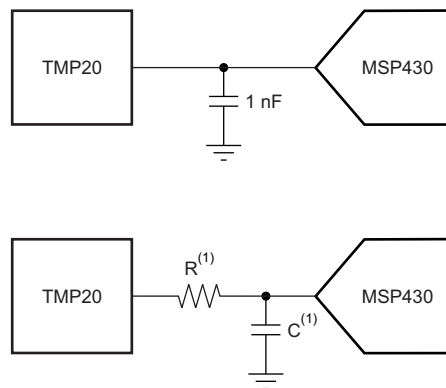

Copyright © 2017, Texas Instruments Incorporated

(1) A series resistor (R) may be required depending upon the amount of capacitance (C) and the amount of source and sink current drawn from the output of the TMP20.

**Figure 11. TMP20 Output Filtering**

## 8.2 Typical Application

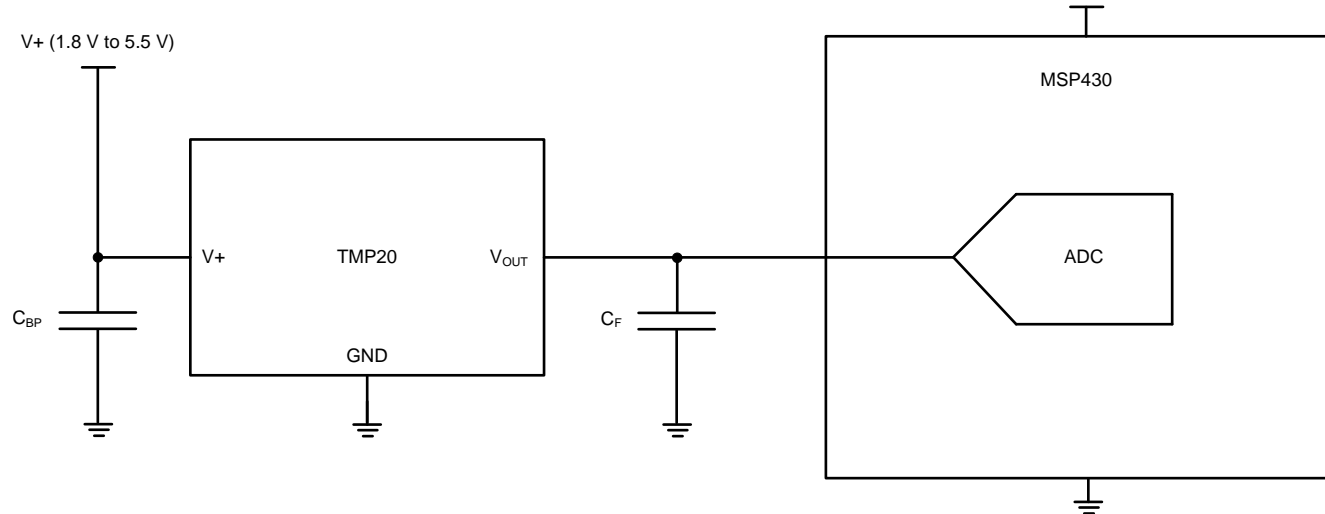

Copyright © 2017, Texas Instruments Incorporated

**Figure 12. Suggested Connections to a MCU ADC**

### 8.2.1 Design Requirements

ADCs that are found in microcontrollers (such as the MSP430 line of microcontrollers) take charge during the sampling phase. A high sampling frequency results in too much charge pulled into the ADC and sags the output voltage of the TMP20, which results in a reading that is hotter than normal. To mitigate this, place a capacitor ( $C_F$ ) between the TMP20 and the ADC. The capacitor functions as a charge reservoir.

### 8.2.2 Detailed Design Procedure

The size of  $C_F$  depends on the size of the internal sampling capacitor and the sampling frequency. The charge requirements may vary because not all ADCs have identical input stages. This general ADC application is shown as an example only.

### 8.2.3 Application Curves

Figure 13 shows the quiescent current versus temperature.

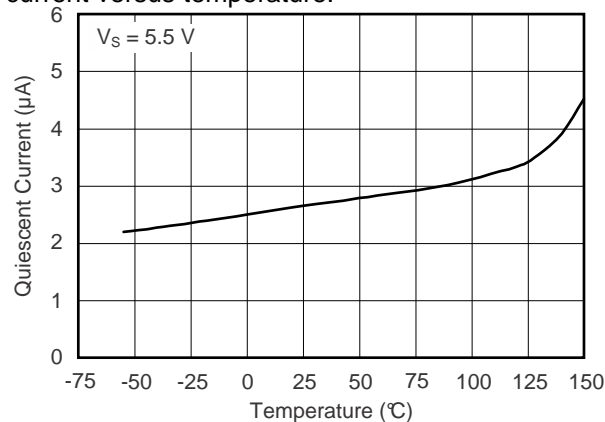

**Figure 13. Quiescent Current vs Temperature**

## 9 Power Supply Recommendations

The low supply current and supply range of 1.8 V to 5.5 V enable the TMP20 to be powered from multiple supply sources.

Power supply bypassing is optional and is typically dependent on the noise of the power supply. In noisy systems, adding bypass capacitors may be necessary to decrease the noise that couples to the output of the TMP20.

## 10 Layout

### 10.1 Layout Guidelines

The substrate on the TMP20AIDCK package is directly connected through conductive epoxy to the flag that connects pin 2 on the lead frame. Consequently, pin 2 is the best lead for a conductive thermal connection to the TMP20 die. The optimal electrical connection for this pin is ground (GND).

#### CAUTION

Do not attempt to connect pin 2 (DCK package) to any electrical potential other than ground.

If it is not possible to connect pin 2 to ground, it is possible to electrically isolate this pin (that is, leave it floating). Take care when electrically isolating this pin because any noise or electromagnetic interference or radio frequency interference (EMI or RFI) spikes that couple in through this pin can cause erroneous temperature results.

shows a proper layout of the TMP20 with correct electrical and thermal connections to pin 2.

### 10.2 Layout Example

Figure 14 shows a layout of the TMP20 with proper electrical and thermal connections to pin 2.

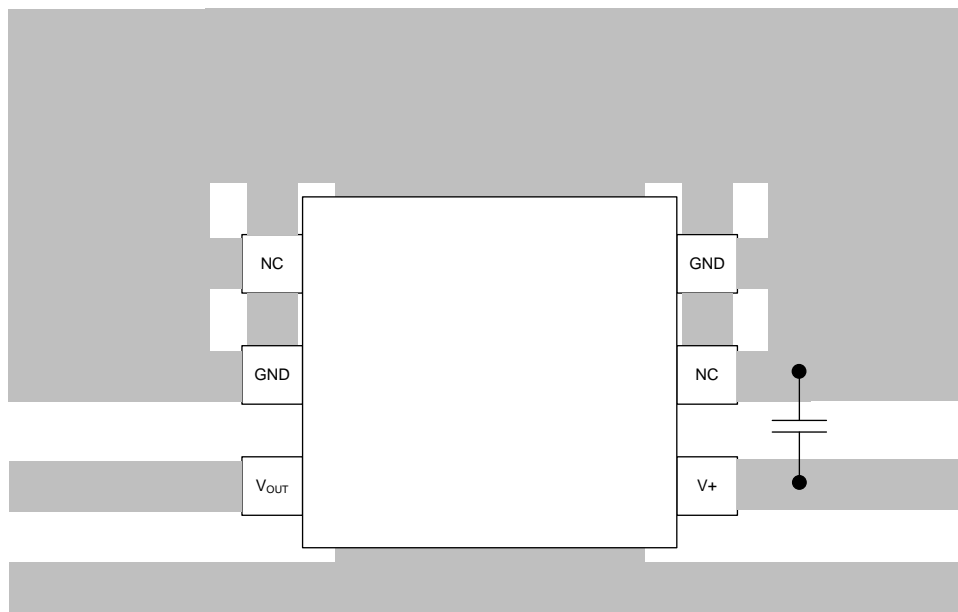

**Figure 14. TMP20 Layout With Proper Electrical and Thermal Connections**

## 11 Device and Documentation Support

### 11.1 Device Support

#### 11.1.1 TINA-TI (Free Download Software)

TINA is a simple, powerful, and easy-to-use circuit simulation program based on a SPICE engine. TINA-TI is a free, fully functional version of the TINA software, preloaded with a library of macromodels in addition to a range of passive and active models. It provides all the conventional dc, transient, and frequency domain analysis of SPICE and additional design capabilities.

Available as a free download from the [WEBENCH® Design Center](#), TINA-TI offers extensive post-processing capability that allows users to format results in a variety of ways.

Virtual instruments offer users the ability to select input waveforms and probe circuit nodes, voltages, and waveforms, creating a dynamic quick-start tool.

Figure 15 and Figure 16 show example TINA-TI circuits for the TMP20 that can develop, modify, and assess the circuit design for specific applications. Links to download these simulation files are given below.

##### 11.1.1.1 Using TINA-TI SPICE-Based Analog Simulation Program with the TMP20

**NOTE**

These files require that the TINA software (from DesignSoft) or TINA-TI software be installed. Download the free TINA-TI software from the [TINA-TI folder](#).

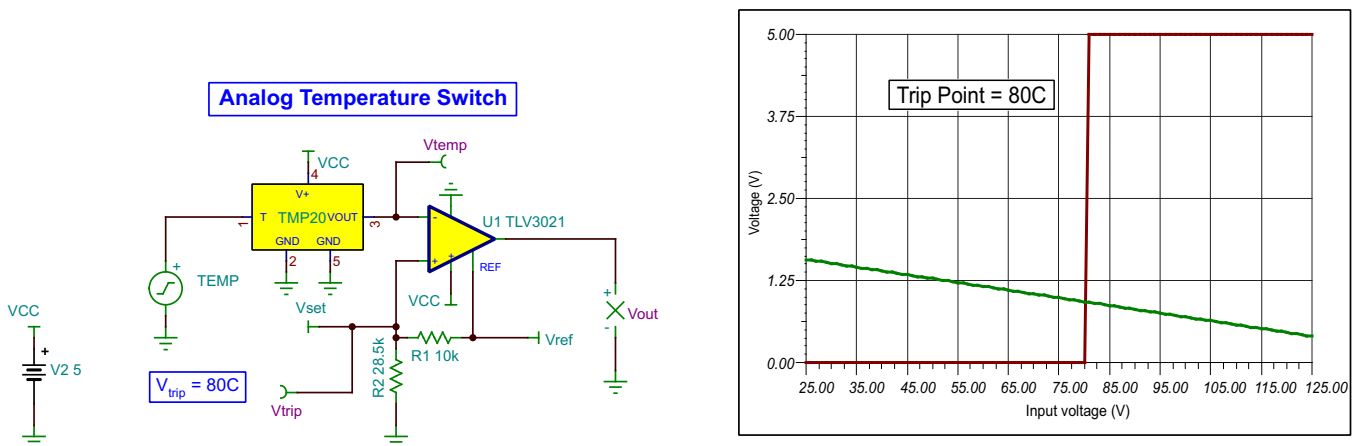

Copyright © 2017, Texas Instruments Incorporated

Note: The TMP20 TINA model is preliminary only.

**Figure 15. Analog Temperature Switch**

To download a compressed file that contains the TINA-TI simulation file for this circuit, visit the [WEBENCH® Design Center](#).

Device Support (continued)

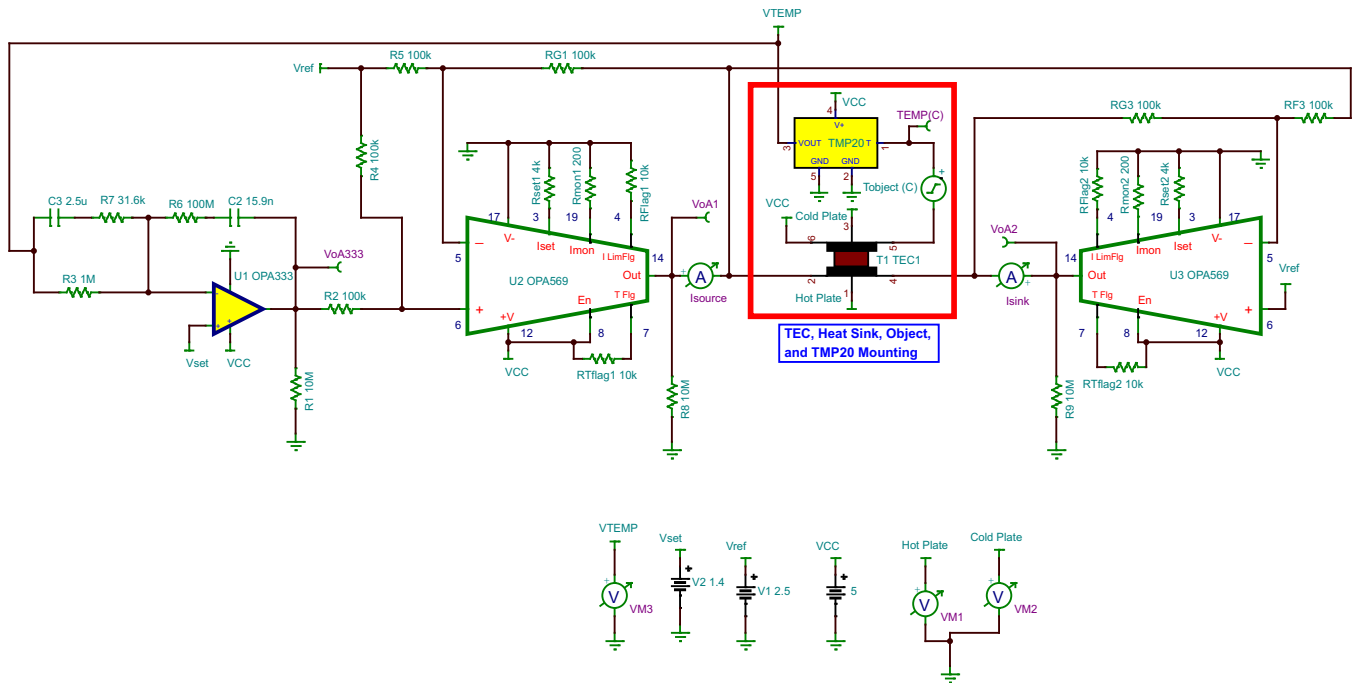

Copyright © 2017, Texas Instruments Incorporated

- (1) The TMP20 TINA model is preliminary only.
- (2) Parameters and definitions:
  - a.  $T_{object}$  = Temperature of the object to be cooled (in °C)
  - b.  $V_{set}$  = Voltage that corresponds to the desired output temperature from the TMP20
  - c.  $V_{TEMP}$  = Voltage output of the TMP20
  - d. Hotplate = TEC plate on opposite side of object
  - e. Coldplate = TEC plate in contact with object
- (3) In this configuration, the TEC driver can cool to  $-T^{\circ}C$  and heating to  $41^{\circ}C$ ; the  $V_{set}$  range is 1.38 V to 1.95 V. The OPA569 device outputs =  $\pm 1.65$  A,  $\pm 0.5$  V to  $\pm 4.5$  V. The 10-M $\Omega$  resistors are for TINA convergence.
- (4) For convergence in TINA software: In **Analysis/Set Analysis Parameters** menu, set *shunt conductance* = 1 p.

Figure 16. Thermoelectric Cooler

To download a compressed file that contains the TINA-TI simulation file for this circuit, see [Thermoelectric Cooler](#).

## Device Support (continued)

### 11.1.2 Development Support

[WEBENCH® Design Center](#)

[TINA-TI folder](#)

[Analog Temperature Switch](#)

[Thermoelectric Cooler](#)

### 11.2 Receiving Notification of Documentation Updates

To receive notification of documentation updates, navigate to the device product folder on ti.com. In the upper right corner, click on *Alert me* to register and receive a weekly digest of any product information that has changed. For change details, review the revision history included in any revised document.

### 11.3 Community Resources

The following links connect to TI community resources. Linked contents are provided "AS IS" by the respective contributors. They do not constitute TI specifications and do not necessarily reflect TI's views; see TI's [Terms of Use](#).

**TI E2E™ Online Community** *TI's Engineer-to-Engineer (E2E) Community*. Created to foster collaboration among engineers. At e2e.ti.com, you can ask questions, share knowledge, explore ideas and help solve problems with fellow engineers.

**Design Support** *TI's Design Support* Quickly find helpful E2E forums along with design support tools and contact information for technical support.

### 11.4 Trademarks

E2E is a trademark of Texas Instruments.  
All other trademarks are the property of their respective owners.

### 11.5 Electrostatic Discharge Caution



These devices have limited built-in ESD protection. The leads should be shorted together or the device placed in conductive foam during storage or handling to prevent electrostatic damage to the MOS gates.

### 11.6 Glossary

[SLYZ022](#) — *TI Glossary*.

This glossary lists and explains terms, acronyms, and definitions.

## 12 Mechanical, Packaging, and Orderable Information

The following pages include mechanical, packaging, and orderable information. This information is the most current data available for the designated devices. This data is subject to change without notice and revision of this document. For browser-based versions of this data sheet, refer to the left-hand navigation.

**PACKAGING INFORMATION**

Orderable Device	Status (1)	Package Type	Package Drawing	Pins	Package Qty	Eco Plan (2)	Lead finish/ Ball material (6)	MSL Peak Temp (3)	Op Temp (°C)	Device Marking (4/5)	Samples
TMP20AIDCKR	ACTIVE	SC70	DCK	5	3000	RoHS & Green	NIPDAU   NIPDAUAG	Level-1-260C-UNLIM	-55 to 125	ODB	<a href="#">Samples</a>
TMP20AIDRLR	ACTIVE	SOT-5X3	DRL	6	4000	RoHS & Green	NIPDAU   NIPDAUAG	Level-1-260C-UNLIM	-55 to 125	ODA	<a href="#">Samples</a>

(1) The marketing status values are defined as follows:

**ACTIVE:** Product device recommended for new designs.

**LIFEBUY:** TI has announced that the device will be discontinued, and a lifetime-buy period is in effect.

**NRND:** Not recommended for new designs. Device is in production to support existing customers, but TI does not recommend using this part in a new design.

**PREVIEW:** Device has been announced but is not in production. Samples may or may not be available.

**OBSOLETE:** TI has discontinued the production of the device.

(2) **RoHS:** TI defines "RoHS" to mean semiconductor products that are compliant with the current EU RoHS requirements for all 10 RoHS substances, including the requirement that RoHS substance do not exceed 0.1% by weight in homogeneous materials. Where designed to be soldered at high temperatures, "RoHS" products are suitable for use in specified lead-free processes. TI may reference these types of products as "Pb-Free".

**RoHS Exempt:** TI defines "RoHS Exempt" to mean products that contain lead but are compliant with EU RoHS pursuant to a specific EU RoHS exemption.

**Green:** TI defines "Green" to mean the content of Chlorine (Cl) and Bromine (Br) based flame retardants meet JS709B low halogen requirements of <=1000ppm threshold. Antimony trioxide based flame retardants must also meet the <=1000ppm threshold requirement.

(3) MSL, Peak Temp. - The Moisture Sensitivity Level rating according to the JEDEC industry standard classifications, and peak solder temperature.

(4) There may be additional marking, which relates to the logo, the lot trace code information, or the environmental category on the device.

(5) Multiple Device Markings will be inside parentheses. Only one Device Marking contained in parentheses and separated by a "~" will appear on a device. If a line is indented then it is a continuation of the previous line and the two combined represent the entire Device Marking for that device.

(6) Lead finish/Ball material - Orderable Devices may have multiple material finish options. Finish options are separated by a vertical ruled line. Lead finish/Ball material values may wrap to two lines if the finish value exceeds the maximum column width.

**Important Information and Disclaimer:**The information provided on this page represents TI's knowledge and belief as of the date that it is provided. TI bases its knowledge and belief on information provided by third parties, and makes no representation or warranty as to the accuracy of such information. Efforts are underway to better integrate information from third parties. TI has taken and continues to take reasonable steps to provide representative and accurate information but may not have conducted destructive testing or chemical analysis on incoming materials and chemicals. TI and TI suppliers consider certain information to be proprietary, and thus CAS numbers and other limited information may not be available for release.

In no event shall TI's liability arising out of such information exceed the total purchase price of the TI part(s) at issue in this document sold by TI to Customer on an annual basis.

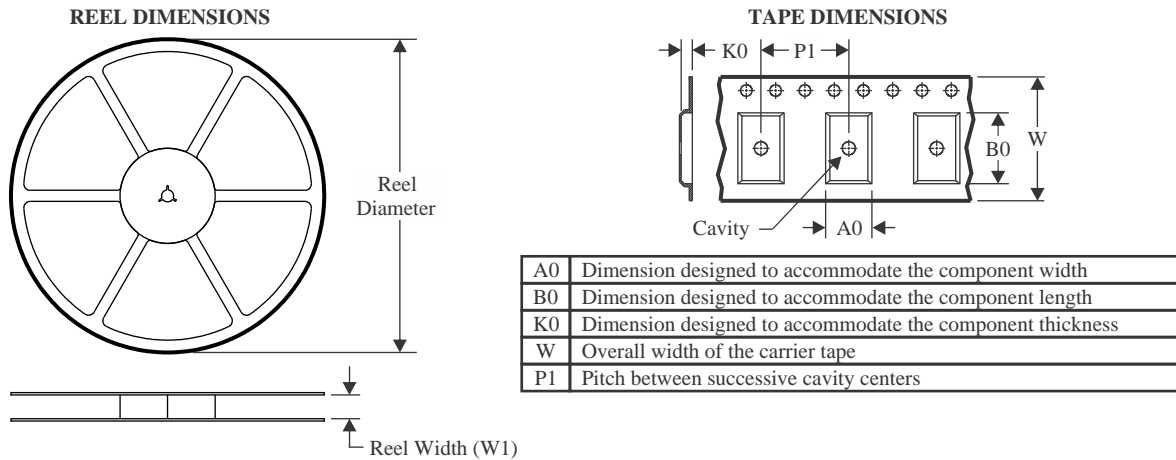

**TAPE AND REEL INFORMATION**

**QUADRANT ASSIGNMENTS FOR PIN 1 ORIENTATION IN TAPE**

\*All dimensions are nominal

Device	Package Type	Package Drawing	Pins	SPQ	Reel Diameter (mm)	Reel Width W1 (mm)	A0 (mm)	B0 (mm)	K0 (mm)	P1 (mm)	W (mm)	Pin1 Quadrant
TMP20AIDCKR	SC70	DCK	5	3000	180.0	8.4	2.47	2.3	1.25	4.0	8.0	Q3
TMP20AIDCKR	SC70	DCK	5	3000	178.0	9.0	2.4	2.5	1.2	4.0	8.0	Q3
TMP20AIDRLR	SOT-5X3	DRL	6	4000	180.0	8.4	2.0	1.8	0.75	4.0	8.0	Q3

**TAPE AND REEL BOX DIMENSIONS**

\*All dimensions are nominal

Device	Package Type	Package Drawing	Pins	SPQ	Length (mm)	Width (mm)	Height (mm)
TMP20AIDCKR	SC70	DCK	5	3000	202.0	201.0	28.0
TMP20AIDCKR	SC70	DCK	5	3000	180.0	180.0	18.0
TMP20AIDRLR	SOT-5X3	DRL	6	4000	210.0	185.0	35.0

# DCK0005A



# PACKAGE OUTLINE

SOT - 1.1 max height

SMALL OUTLINE TRANSISTOR

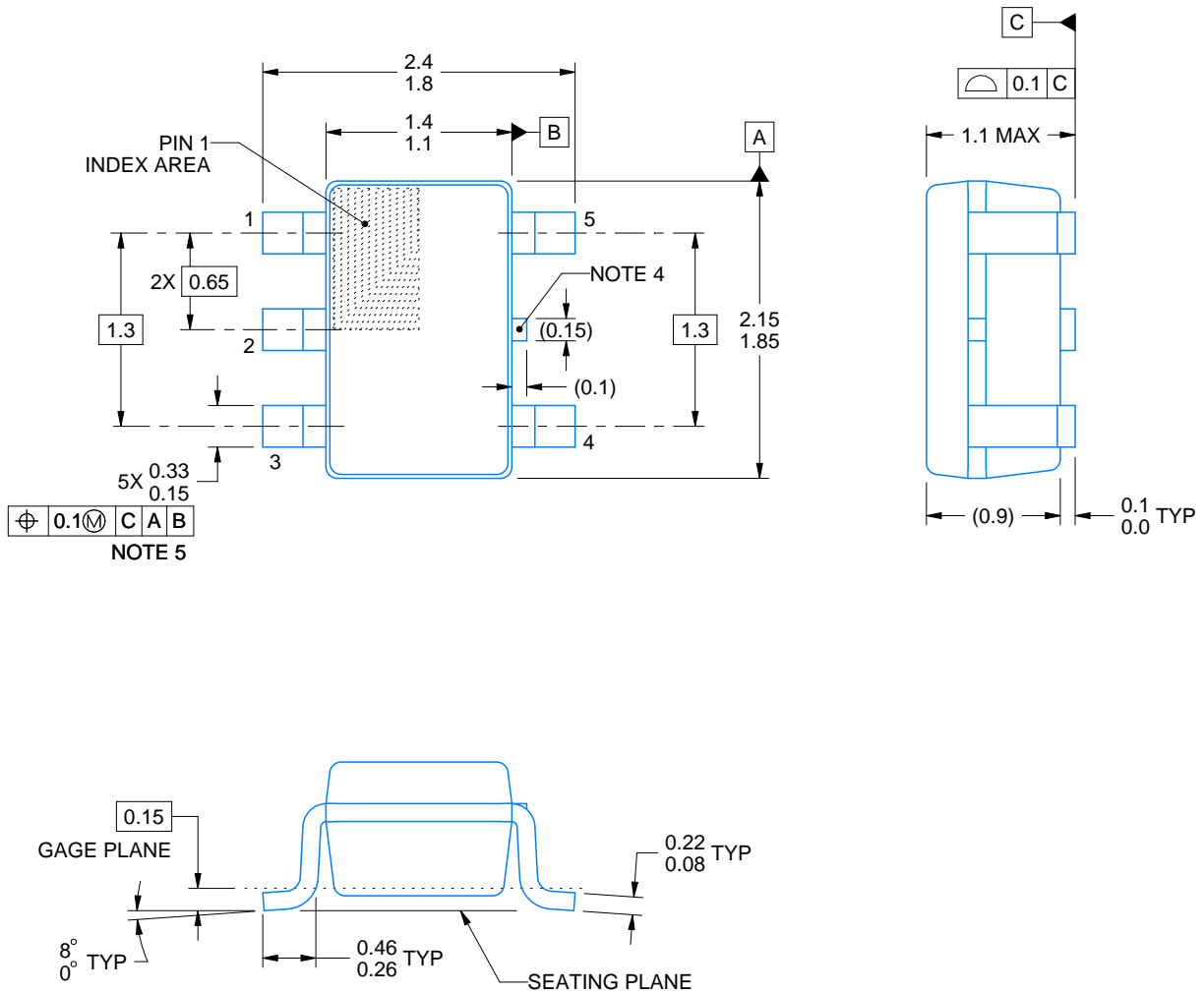

4214834/D 07/2023

NOTES:

1. All linear dimensions are in millimeters. Any dimensions in parenthesis are for reference only. Dimensioning and tolerancing per ASME Y14.5M.
2. This drawing is subject to change without notice.
3. Reference JEDEC MO-203.
4. Support pin may differ or may not be present.
5. Lead width does not comply with JEDEC.

# EXAMPLE BOARD LAYOUT

DCK0005A

SOT - 1.1 max height

SMALL OUTLINE TRANSISTOR

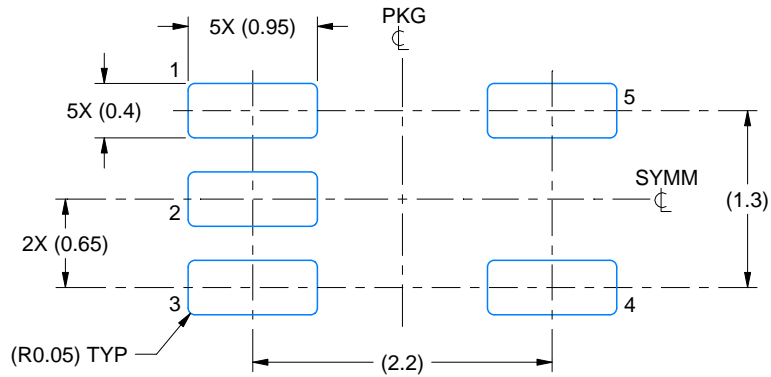

LAND PATTERN EXAMPLE  
EXPOSED METAL SHOWN  
SCALE:18X

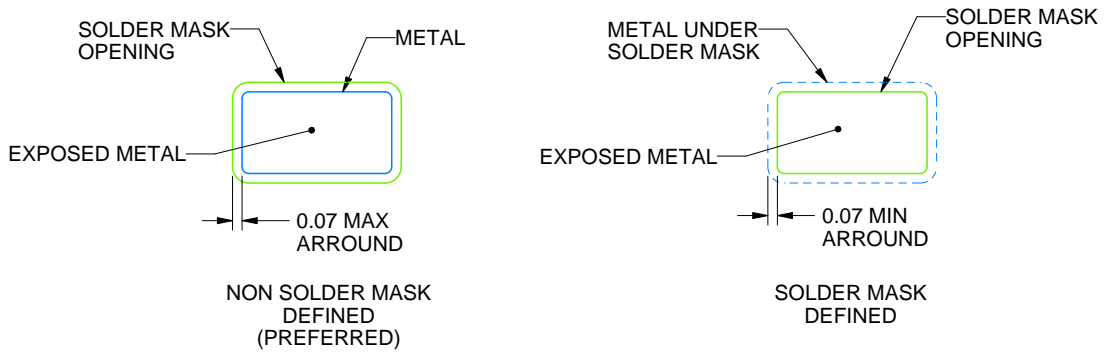

SOLDER MASK DETAILS

4214834/D 07/2023

NOTES: (continued)

- 6. Publication IPC-7351 may have alternate designs.
- 7. Solder mask tolerances between and around signal pads can vary based on board fabrication site.

# EXAMPLE STENCIL DESIGN

DCK0005A

SOT - 1.1 max height

SMALL OUTLINE TRANSISTOR

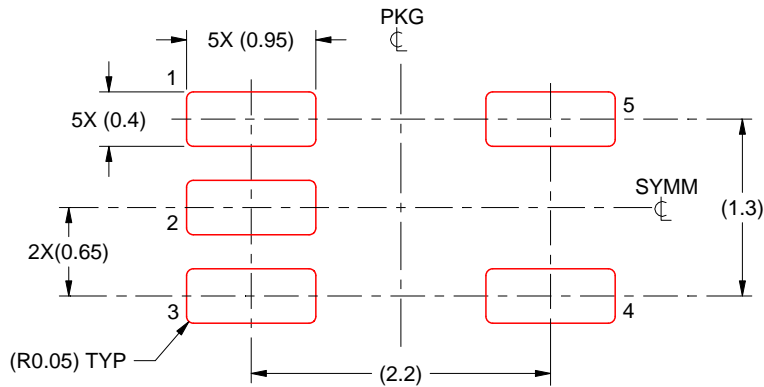

SOLDER PASTE EXAMPLE  
BASED ON 0.125 THICK STENCIL  
SCALE:18X

4214834/D 07/2023

NOTES: (continued)

8. Laser cutting apertures with trapezoidal walls and rounded corners may offer better paste release. IPC-7525 may have alternate design recommendations.
9. Board assembly site may have different recommendations for stencil design.

# DRL0006A

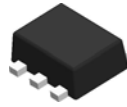

# PACKAGE OUTLINE

## SOT - 0.6 mm max height

PLASTIC SMALL OUTLINE

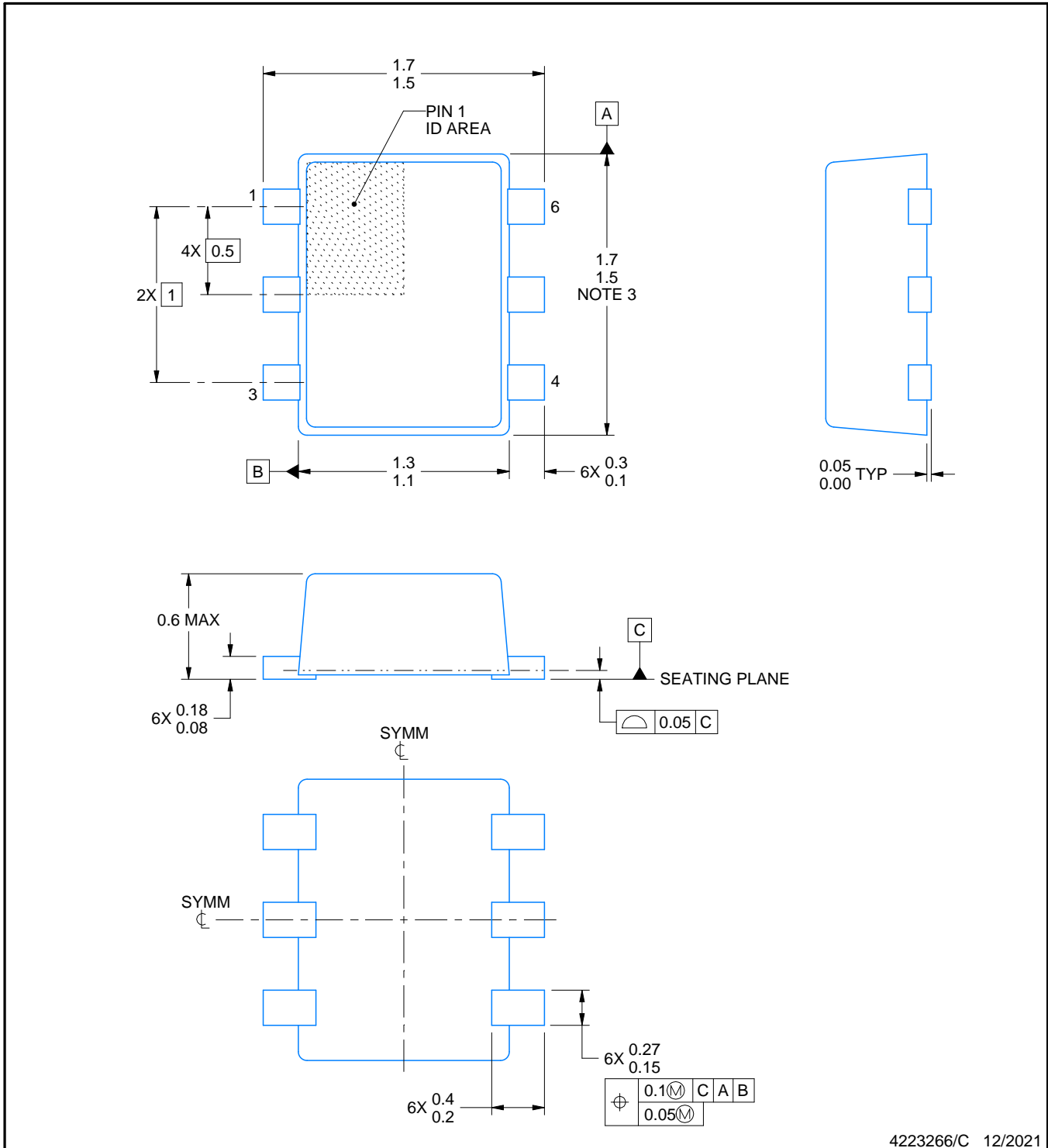

4223266/C 12/2021

### NOTES:

1. All linear dimensions are in millimeters. Any dimensions in parenthesis are for reference only. Dimensioning and tolerancing per ASME Y14.5M.
2. This drawing is subject to change without notice.
3. This dimension does not include mold flash, protrusions, or gate burrs. Mold flash, protrusions, or gate burrs shall not exceed 0.15 mm per side.
4. Reference JEDEC registration MO-293 Variation UAAD

# EXAMPLE BOARD LAYOUT

DRL0006A

SOT - 0.6 mm max height

PLASTIC SMALL OUTLINE

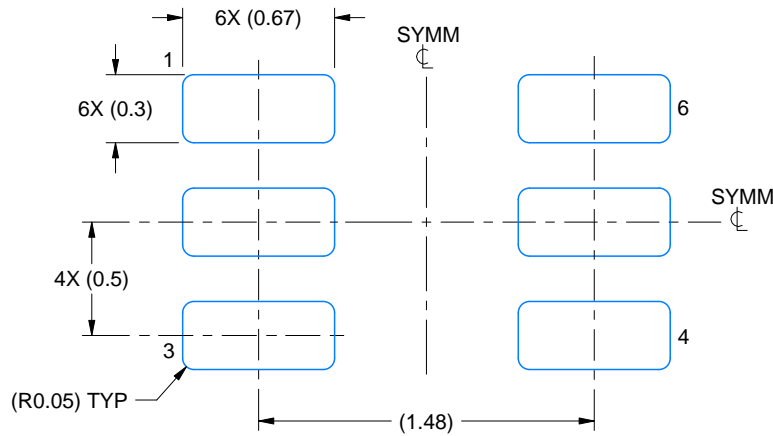

LAND PATTERN EXAMPLE  
SCALE:30X

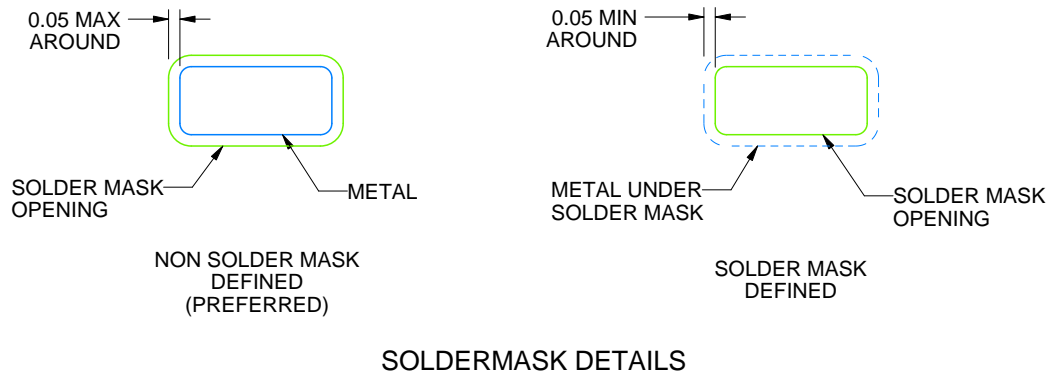

SOLDERMASK DETAILS

4223266/C 12/2021

NOTES: (continued)

5. Publication IPC-7351 may have alternate designs.
6. Solder mask tolerances between and around signal pads can vary based on board fabrication site.
7. Land pattern design aligns to IPC-610, Bottom Termination Component (BTC) solder joint inspection criteria.

# EXAMPLE STENCIL DESIGN

DRL0006A

SOT - 0.6 mm max height

PLASTIC SMALL OUTLINE

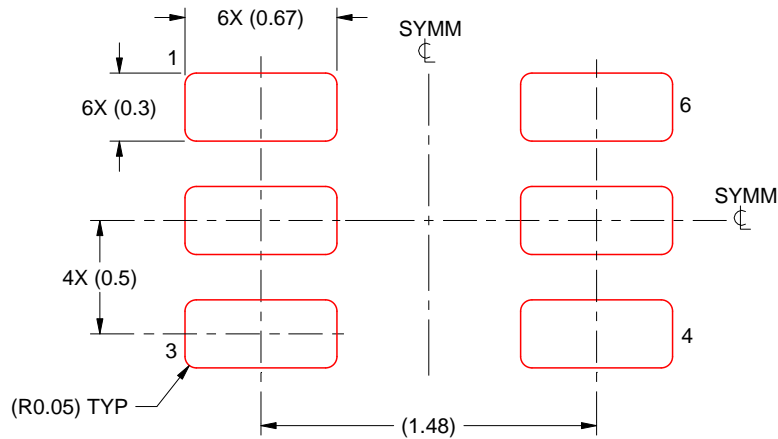

SOLDER PASTE EXAMPLE  
BASED ON 0.1 mm THICK STENCIL  
SCALE:30X

4223266/C 12/2021

NOTES: (continued)

8. Laser cutting apertures with trapezoidal walls and rounded corners may offer better paste release. IPC-7525 may have alternate design recommendations.
9. Board assembly site may have different recommendations for stencil design.

## IMPORTANT NOTICE AND DISCLAIMER

TI PROVIDES TECHNICAL AND RELIABILITY DATA (INCLUDING DATA SHEETS), DESIGN RESOURCES (INCLUDING REFERENCE DESIGNS), APPLICATION OR OTHER DESIGN ADVICE, WEB TOOLS, SAFETY INFORMATION, AND OTHER RESOURCES "AS IS" AND WITH ALL FAULTS, AND DISCLAIMS ALL WARRANTIES, EXPRESS AND IMPLIED, INCLUDING WITHOUT LIMITATION ANY IMPLIED WARRANTIES OF MERCHANTABILITY, FITNESS FOR A PARTICULAR PURPOSE OR NON-INFRINGEMENT OF THIRD PARTY INTELLECTUAL PROPERTY RIGHTS.

These resources are intended for skilled developers designing with TI products. You are solely responsible for (1) selecting the appropriate TI products for your application, (2) designing, validating and testing your application, and (3) ensuring your application meets applicable standards, and any other safety, security, regulatory or other requirements.

These resources are subject to change without notice. TI grants you permission to use these resources only for development of an application that uses the TI products described in the resource. Other reproduction and display of these resources is prohibited. No license is granted to any other TI intellectual property right or to any third party intellectual property right. TI disclaims responsibility for, and you will fully indemnify TI and its representatives against, any claims, damages, costs, losses, and liabilities arising out of your use of these resources.

TI's products are provided subject to [TI's Terms of Sale](#) or other applicable terms available either on [ti.com](https://www.ti.com) or provided in conjunction with such TI products. TI's provision of these resources does not expand or otherwise alter TI's applicable warranties or warranty disclaimers for TI products.

TI objects to and rejects any additional or different terms you may have proposed.

Mailing Address: Texas Instruments, Post Office Box 655303, Dallas, Texas 75265  
Copyright © 2024, Texas Instruments Incorporated

## Looking for pricing, stock, or lifecycle information?

Click below to explore more details on WIN SOURCE:

 [View TMP20AIDCKT on WIN SOURCE](#)

 [Texas Instruments](#) Information

## Optimize Your Supply Chain with WIN SOURCE Solutions

-  Global Sourcing Solution
-  Obsolete Management
-  Cost Control Management
-  Shortage Management
-  Alternative Solution
-  Excess Inventory Management