



THE DATASHEET OF LM3553SDX/NOPB



LM3553 1.2A Dual Flash LED Driver System with I²C Compatible Interface

Check for Samples: [LM3553](#)

FEATURES

- Accurate and Programmable LED Current up to 1.2A in 128 Steps
- Total Solution Size < 30mm²
- 90% Peak Efficiency
- Drives 2 LEDs in Series with 1.2A from 5V Input
- Drives 2 LEDs in Series with 600mA from 3.0V Input
- Drives 1 LED with 1.2A from 3.0V Input
- Adjustable Over-Voltage Protection Allows for Single or Series LED Operation
- Four Operating Modes: Torch, Flash, Indicator, and Voltage Mode (4.98V)
- Programmable Flash Pulse Safety Timer in 16 Steps
- TX Input Ensures Synchronization with RF Power Amplifier Pulse or Prevents LED from Overheating
- LED Disconnect During Shutdown
- Flash/Imager Synchronization via F_{EN} Pin
- Active Low Hardware Reset

- Multi-Function Pin ($\overline{\text{RESET}}$ and GPIO)
- Low Profile 12-pin WSON Package (DQB0012A: 3mm x 3mm x 0.8mm, 0.4mm pitch)

APPLICATIONS

- Camera Phone LED Flash
- Smartphone and PDA Flash
- LED Backlight

DESCRIPTION

The LM3553 is a fixed frequency, current mode step-up DC/DC converter with two regulated current sinks. The device is capable of driving loads up to 1.2A from a single-cell Li-Ion battery.

The LM3553 includes a TX pin that forces Torch mode during a flash event allowing for synchronization between the RF power amplifier and Flash/Torch modes. It also includes a multi-function pin (M/F) that can serve as a GPIO and a hardware RESET pin.

The LM3553 is available in a 3mm by 3mm package.

Typical Application Circuits

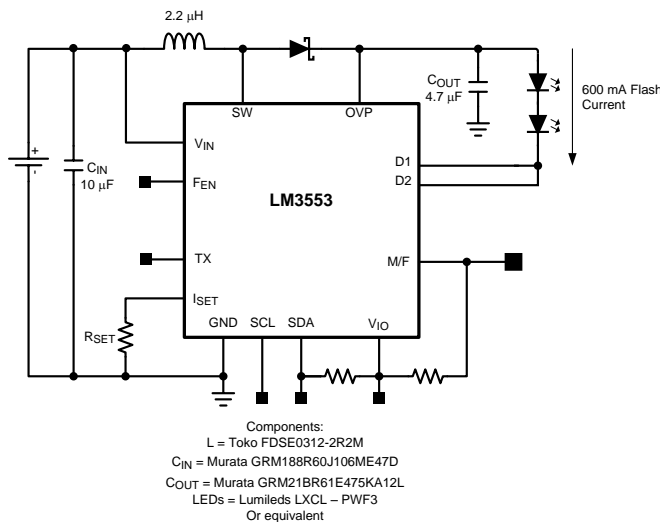
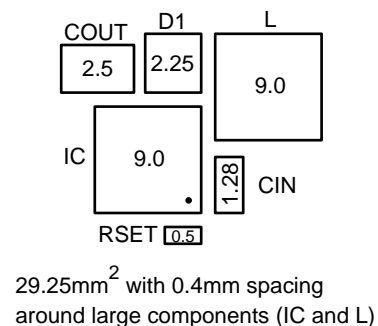
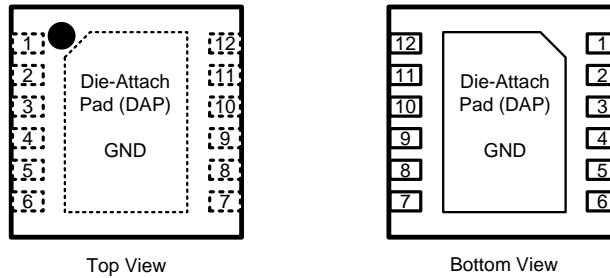

Figure 1.

Figure 2. Solution Size

Please be aware that an important notice concerning availability, standard warranty, and use in critical applications of Texas Instruments semiconductor products and disclaimers thereto appears at the end of this data sheet.

All trademarks are the property of their respective owners.

Connection Diagram

12 Pin 3mm x 3mm WSON Package DQB0012A



PIN DESCRIPTIONS

Pin	Name	Function
4	V_{IN}	Input Voltage. Input range: 2.7V to 5.5V.
5	SW	Switch Pin
6	OVP	Over Voltage Protection Pin
2, 11	D1, D2	Regulated current sink inputs
DAP	GND	Ground
1	I_{SET}	Current sense input. Connect a 1% 16.5k Ω resistor to ground to set the full scale LED current.
3	F_{EN}	Flash enable pin.
8	SCL	Serial clock pin.
10	SDA	Serial data I/O pin.
9	VIO	Digital Reference Voltage level input pin.
7	TX	RF PA synchronization control pin. High = Forced Torch mode.
12	M/F	Hardware RESET or General purpose I/O. Function set through Multi-Function Control Register



These devices have limited built-in ESD protection. The leads should be shorted together or the device placed in conductive foam during storage or handling to prevent electrostatic damage to the MOS gates.

Absolute Maximum Ratings ⁽¹⁾⁽²⁾⁽³⁾

V_{IN} pin: Voltage to GND	-0.3V to 6V
SW, OVP pin: Voltage to GND	-0.3V to 25V
D1, D2 pins: Voltage to GND	-0.3V to 25V
VIO, SCL, SDA	-0.3V to 6V
TX, FEN, M/F	-0.3V to 6V
Continuous Power Dissipation ⁽⁴⁾	Internally Limited
Junction Temperature (T_{J-MAX})	150°C
Storage Temperature Range	-65°C to +150
Maximum Lead Temperature (Soldering)	⁽⁵⁾
ESD Rating ⁽⁶⁾ Human Body Model	2.5kV

- (1) Absolute Maximum Ratings indicate limits beyond which damage to the component may occur. Operating Ratings are conditions under which operation of the device is specified. Operating Ratings do not imply performance limits. For performance limits and associated test conditions, see the Electrical Characteristics tables.
- (2) All voltages are with respect to the potential at the GND pin.
- (3) If Military/Aerospace specified devices are required, please contact the Texas Instruments Sales Office/ Distributors for availability and specifications.
- (4) Internal thermal shutdown circuitry protects the device from permanent damage. Thermal shutdown engages at $T_J=140^\circ\text{C}$ (typ.) and disengages at $T_J=120^\circ\text{C}$ (typ.).
- (5) For detailed soldering specifications and information, please refer to Texas Instruments Application Note: AN-1187 [SNOA401](#) for Recommended Soldering Profiles.
- (6) The human body model is a 100pF capacitor discharged through a 1.5k Ω resistor into each pin. (MIL-STD-883 3015.7)

Operating Ratings ⁽¹⁾⁽²⁾

Input Voltage Range	2.7V to 5.5V
Junction Temperature (T _J) Range	-30°C to +125°C
Ambient Temperature (T _A) Range ⁽³⁾	-30°C to +85°C

- (1) Absolute Maximum Ratings indicate limits beyond which damage to the component may occur. Operating Ratings are conditions under which operation of the device is specified. Operating Ratings do not imply performance limits. For performance limits and associated test conditions, see the Electrical Characteristics tables.
- (2) All voltages are with respect to the potential at the GND pin.
- (3) In applications where high power dissipation and/or poor package thermal resistance is present, the maximum ambient temperature may have to be derated. Maximum ambient temperature (T_{A-MAX}) is dependent on the maximum operating junction temperature (T_{J-MAX-OP} = 125°C), the maximum power dissipation of the device in the application (P_{D-MAX}), and the junction-to-ambient thermal resistance of the part/package in the application (θ_{JA}), as given by the following equation: T_{A-MAX} = T_{J-MAX-OP} – (θ_{JA} × P_{D-MAX}).

Thermal Properties

Junction-to-Ambient Thermal Resistance (θ _{JA}), DQB0012A Package ⁽¹⁾	36.7°C/W
--	----------

- (1) Junction-to-ambient thermal resistance is highly application and board-layout dependent. In applications where high maximum power dissipation exists, special care must be paid to thermal dissipation issues in board design.

Electrical Characteristics

Limits in standard typeface are for $T_A = +25^\circ\text{C}$. Limits in boldface type apply over the full operating junction temperature range ($-30^\circ\text{C} \leq T_J \leq +125^\circ\text{C}$). Unless otherwise noted: $V_{IN} = 3.6\text{V}$, $R_{SET} = 16.5\text{k}\Omega$, $V_{D1} = V_{D2} = 500\text{mV}$, VFB bit = '0', FEN = '0', TX = '0', Flash Current Level = Full-Scale. ⁽¹⁾⁽²⁾⁽³⁾

Symbol	Parameter	Conditions	Min	Typ	Max	Units
$I_{LED-SUM}$	Flash LED Current: $I_{D1} + I_{D2}$	Flash Mode VDX = Regulation Voltage	930	1020	1110	mA
		Flash Mode VDX = Regulation Voltage RSET = 13.7k Ω		1200		
$I_{LED-IND}$	Indicator Current Level	Indicator Mode		20		mA
V_{MREG}	Output Voltage Regulation in Voltage Mode	VM = '1', EN1 = EN0 = '0' No Load	4.65	4.98	5.30	V
I_Q	Quiescent Supply Current	$V_{D1,D2} = 0\text{V}$ (Switching)		1.0	1.2	mA
I_{SD}	Shutdown Supply Current	Device Disabled		3.8	6.0	μA
I_{Dx} / I_{SET}	LED Current to Set Current Ratio	$I_{Dx} = 500\text{mA}$		6770		A / A
V_{SET}	I_{SET} Pin Voltage			1.24		V
$V_{D1,D2}$	Current Sink Regulation Voltage	VFB Bit = '0'		450		mV
		VFB Bit = '1'		350		
$I_{Dx-MATCH}$	Current Sink Matching	VDX = Regulation Voltage		2		%
R_{DSON}	NMOS Switch Resistance			0.25		Ω
I_{CL}	NMOS Switch Current Limit	OCL Bit = '0'	2.2	2.5	2.8	A
		OCL Bit = '1'	1.53	1.70	1.87	
I_{L-SW}	SW Pin Leakage Current	Switch Off, $V_{SW} = 3.6\text{V}$, OVP Mode = '0'		10		nA
I_{L-Dx}	D1, D2 Pin Leakage	$V_{Dx} = 3.5\text{V}$		10		nA
V_{OVP}	Output Over-Voltage Protection Trip Point	OVP Mode = '1'	18.00	18.90	19.65	V
		OVP Mode = '0'	5.4	5.6	5.85	
OVP_{Hyst}	Over-Voltage Protection Hysteresis OVP to Normal Operation	OVP Mode = '1'		1.6		V
		OVP Mode = '0'		0.6		
I_{L-OVP}	OVP Pin Leakage Current	$V_{OVP} = 3.6\text{V}$		10		nA
f_{SW}	Switching Frequency		1.0	1.2	1.35	MHz
t_{FD-MIN}	Minimum Flash Duration Step	$t_{FD-MIN} = 16 \div f_{SW}$		12.8		$\mu\text{sec.}$
D_{MAX}	Maximum Duty Cycle			92		%
D_{MIN}	Minimum Duty Cycle			6		%
$Th_{TX,F-EN}$	TX, FEN Pin Threshold	On	1.0		VIN	V
		Off	0		0.6	
Multi-Function Pin (M/F) Voltage Specifications						
$V_{M/F}$	Multi-Function Pin Threshold Voltages	Input Logic High "1"	0.94		VIN	V
		Input Logic Low "0"	0		0.64	
V_{OL}	Output Logic Low "0"	$I_{LOAD} = 4.2\text{mA}$, GPIO Mode			400	mV
I²C Compatible Voltage Specifications (SCL, SDIO, VIO)						
VIO	Serial Bus Voltage Level		1.45		VIN	V
V_{IL}	Input Logic Low "0"	VIO = 3.0V	0		0.38 x VIO	V
V_{IH}	Input Logic High "1"	VIO = 3.0V	0.55 x VIO		VIO	V
V_{OL}	Output Logic Low "0"	$I_{LOAD} = 3.7\text{mA}$			400	mV

(1) All voltages are with respect to the potential at the GND pin.

(2) Min and Max limits are specified by design, test, or statistical analysis. Typical (Typ) numbers represent the most likely norm. Unless otherwise specified, conditions for Typ specifications are: $V_{IN} = 3.6\text{V}$ and $T_A = 25^\circ\text{C}$.

(3) All testing for the LM3553 is done open-loop.

Electrical Characteristics (continued)

Limits in standard typeface are for $T_A = +25^\circ\text{C}$. Limits in boldface type apply over the full operating junction temperature range ($-30^\circ\text{C} \leq T_J \leq +125^\circ\text{C}$). Unless otherwise noted: $V_{IN} = 3.6\text{V}$, $R_{SET} = 16.5\text{k}\Omega$, $V_{D1} = V_{D2} = 500\text{mV}$, VFB bit = '0', FEN = '0', TX = '0', Flash Current Level = Full-Scale. ⁽¹⁾⁽²⁾⁽³⁾

Symbol	Parameter	Conditions	Min	Typ	Max	Units
I²C Compatible Interface Timing Specifications (SCL, SDIO, VIO)						
t_1	SCL (Clock Period)		2.5			μs
t_2	Data In Setup Time to SCL High		100			ns
t_3	Data Out stable After SCL Low		0			ns
t_4	SDA Low Setup Time to SCL Low (Start)		100			ns
t_5	SDA High Hold Time After SCL High (Stop)		100			ns

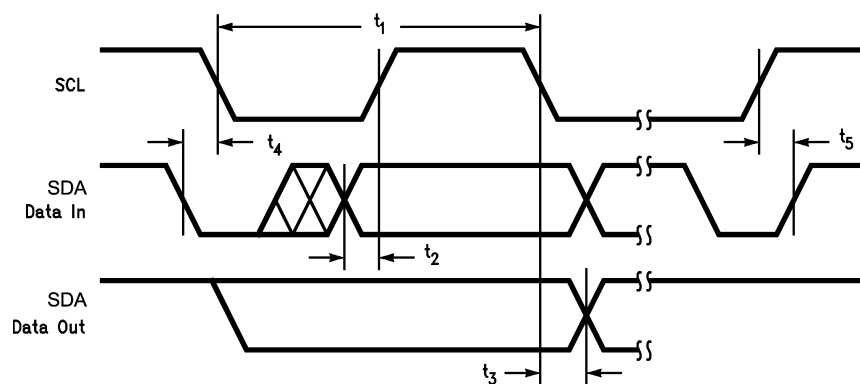

Typical Performance Characteristics

Unless otherwise specified: $T_A = 25^\circ\text{C}$; $V_{IN} = 3.6\text{V}$; $V_{M/F} = V_{IN}$; $R_{SET} = 16.5\text{k}\Omega$; $C_{IN} = 10\mu\text{F}$, $C_{OUT} = 10\mu\text{F}$; $L = 2.2\mu\text{H}$; VFB bit = CL bit = '0'; OVP bit = '0' for 1 LED and VFB = '1' for two series LEDs;

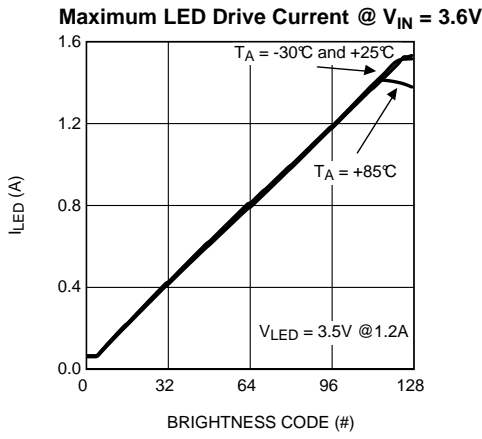

Figure 3.

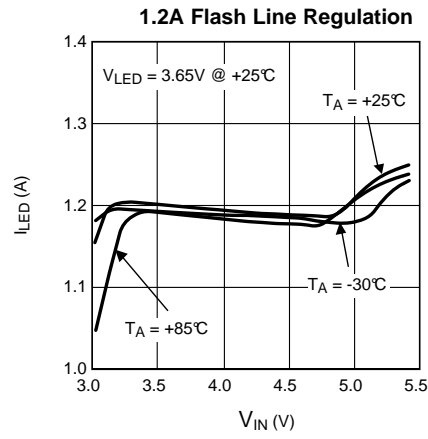

Figure 4.

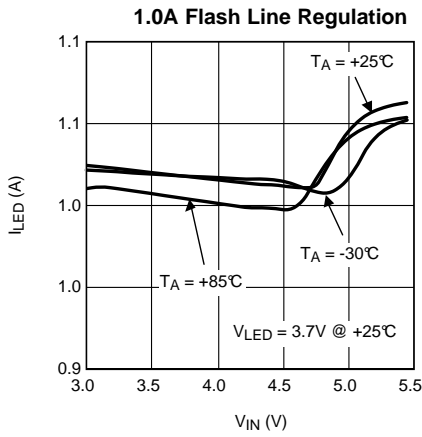

Figure 5.

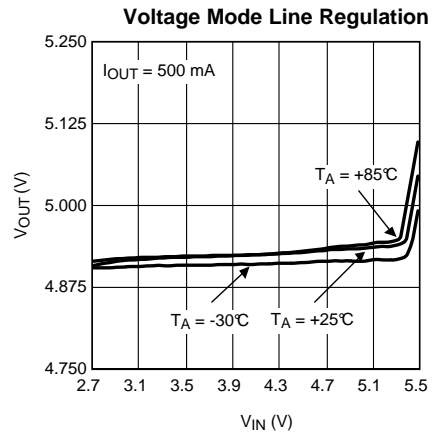

Figure 6.

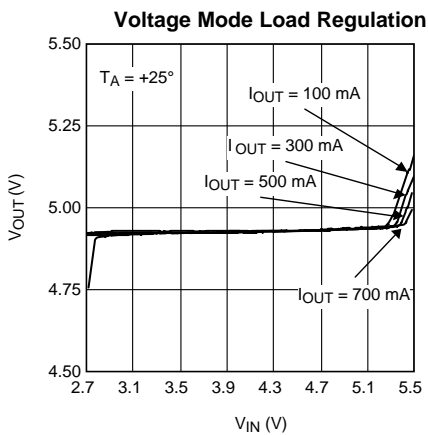

Figure 7.

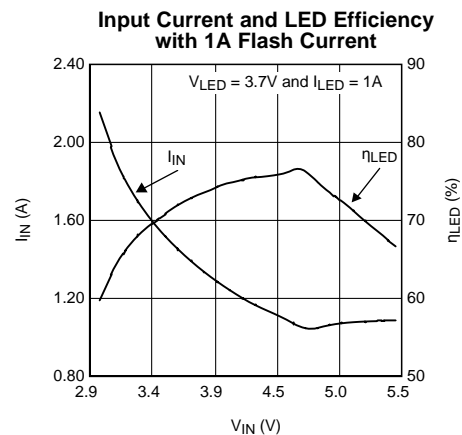

Figure 8.

Typical Performance Characteristics (continued)

Unless otherwise specified: $T_A = 25^\circ\text{C}$; $V_{IN} = 3.6\text{V}$; $V_{M/F} = V_{IN}$; $R_{SET} = 16.5\text{k}\Omega$; $C_{IN} = 10\mu\text{F}$; $C_{OUT} = 10\mu\text{F}$; $L = 2.2\mu\text{H}$; VFB bit = CL bit = '0'; OVP bit = '0' for 1 LED and VFB = '1' for two series LEDs;

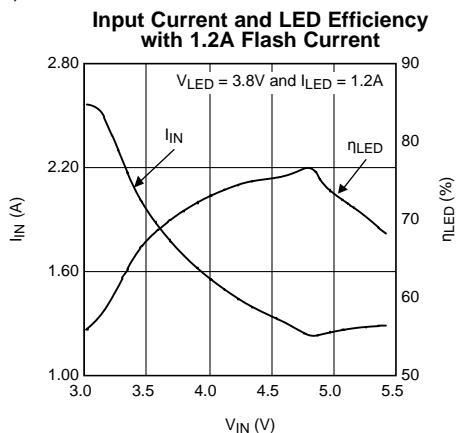

Figure 9.

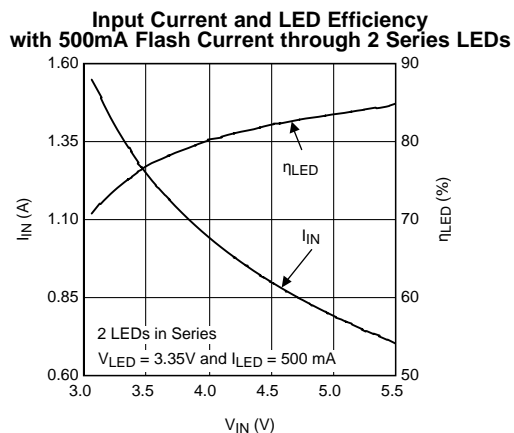

Figure 10.

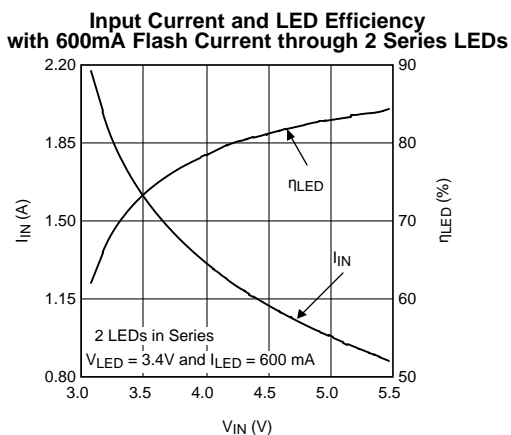

Figure 11.

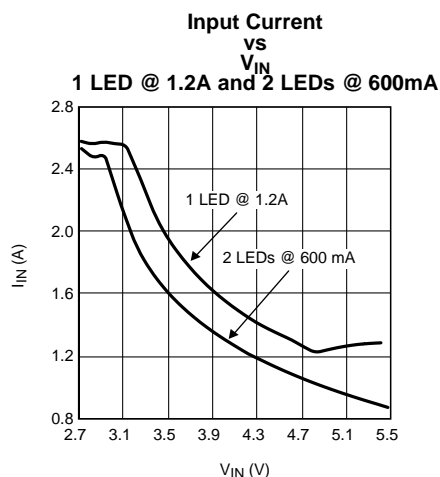

Figure 12.

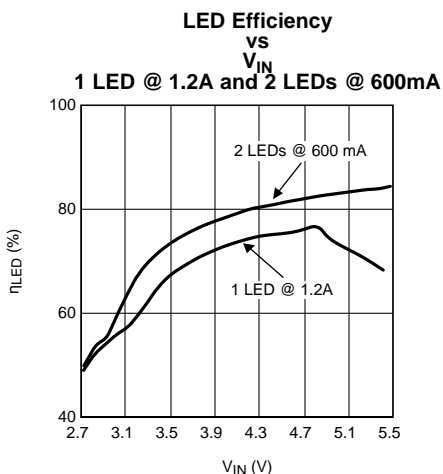

Figure 13.

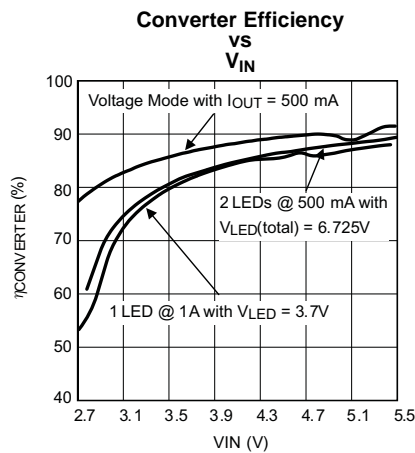
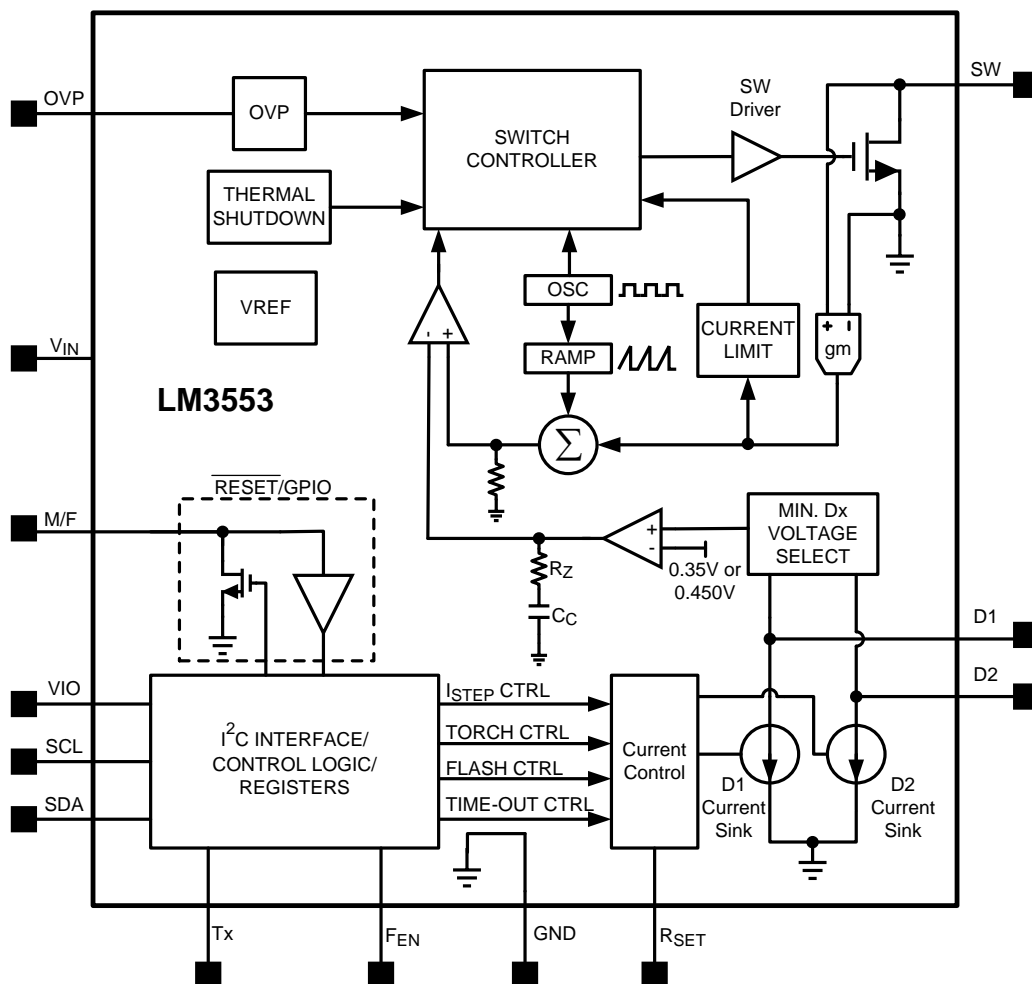

Figure 14.

BLOCK DIAGRAM



Circuit Description

CIRCUIT COMPONENTS

F_{EN} Pin

The flash enable pin, F_{EN} , provides an external method (non-I²C) for starting the flash pulse. When F_{EN} is pulled high, logic '1', the flash current level defined through the I²C interface, will be delivered to the Flash LED. If the F_{EN} pin is driven low during the flash pulse, the flash event will stop. In the event that F_{EN} is not pulled low during the flash pulse, the LM3553 will continue to deliver the flash current until the safety timer duration (set through the I²C interface) is reached.

The LM3553 does not provide a fixed off-time after the flash pulse has ended. Most flash LED manufacturers require that the flash pulse duration be 10% of the total Flash cycle. Example: If the flash pulse duration is set to be 200 milliseconds (Flash Duration Code= 0011), the recommended off time for the LED would be 1.8 seconds. Please consult the LED manufacturers datasheet for exact timing requirements.

If the LM3553 is placed in indicator mode or torch mode through the I²C interface and the F_{EN} pin is pulled high and then low, at the end of the flash event, the LM3553 will return to the mode stored in the General Purpose Register.

It is recommended that an external pull-down be placed between the F_{EN} pin and GND to prevent unwanted LED flashing during system start-up due to unknown control logic states.

T_X Pin

The transmission pin (T_X) can be used to limit the current drawn from the battery during a PA transmission. When the T_X pin is driven high (logic '1') during a flash pulse, the LM3553 will switch to the programmed torch current level. Once the T_X pin is driven low (logic '0'), the LM3553 will return to the flash current if this event occurs within the original flash duration.

It is recommended that an external pull-down be placed between the T_X pin and GND to prevent unwanted LED flashing during system start-up due to unknown control logic states.

M/F Pin

The multi-function pin (M/F) can be configured to provide hardware RESET or a general purpose input/output (GPIO). All functionality is programmed through the I²C compatible interface and set in the M/F pin functionality control register (address 0x20). The default function is a $\overline{\text{RESET}}$, where a logic '1' places the part in the normal operating mode, and a logic '0' places the part into a RESET state. A reset condition will place all LM3553 registers into their default states.

Connection Diagram

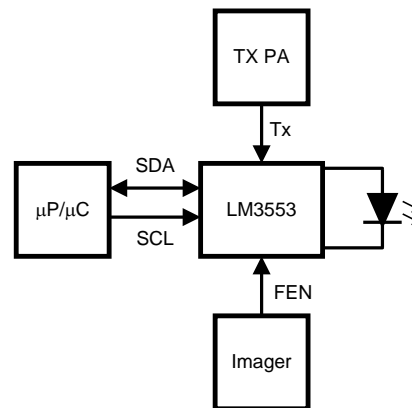

Figure 15. Typical System Configuration

I²C Compatible Interface

DATA VALIDITY

The data on SDA line must be stable during the HIGH period of the clock signal (SCL). In other words, the state of the data line can only be changed when CLK is LOW.

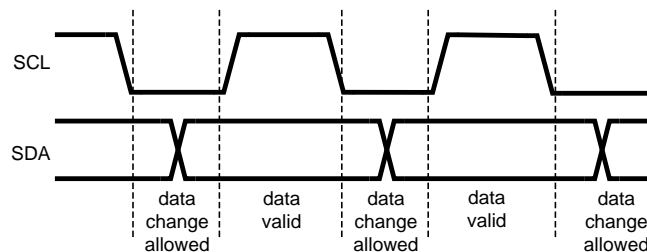

Figure 16. Data Validity Diagram

A pull-up resistor between VIO and SDA must be greater than $[(\text{VIO} - \text{V}_{\text{OL}}) / 3.7\text{mA}]$ to meet the V_{OL} requirement on SDA. Using a larger pull-up resistor results in lower switching current with slower edges, while using a smaller pull-up results in higher switching currents with faster edges.

START AND STOP CONDITIONS

START and STOP conditions classify the beginning and the end of the I²C session. A START condition is defined as SDA signal transitioning from HIGH to LOW while SCL line is HIGH. A STOP condition is defined as the SDA transitioning from LOW to HIGH while SCL is HIGH. The I²C master always generates START and STOP conditions. The I²C bus is considered to be busy after a START condition and free after a STOP condition. During data transmission, the I²C master can generate repeated START conditions. First START and repeated START conditions are equivalent, function-wise. The data on SDA line must be stable during the HIGH period of the clock signal (SCL). In other words, the state of the data line can only be changed when CLK is LOW.

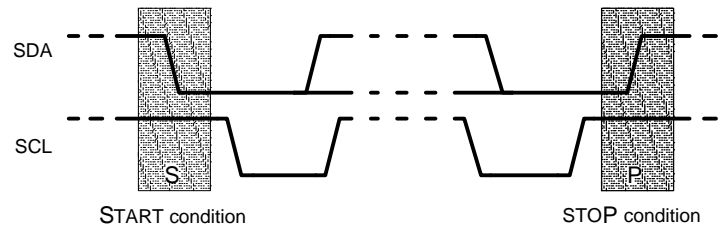

Figure 17. Start and Stop Conditions

TRANSFERRING DATA

Every byte put on the SDA line must be eight bits long, with the most significant bit (MSB) being transferred first. Each byte of data has to be followed by an acknowledge bit. The acknowledge related clock pulse is generated by the master. The master releases the SDA line (HIGH) during the acknowledge clock pulse. The LM3553 pulls down the SDA line during the 9th clock pulse, signifying an acknowledge. The LM3553 generates an acknowledge after each byte has been received.

After the START condition, the I²C master sends a chip address. This address is seven bits long followed by an eighth bit which is a data direction bit (R/W). The LM3553 address is 53h. For the eighth bit, a "0" indicates a WRITE and a "1" indicates a READ. The second byte selects the register to which the data will be written. The third byte contains data to write to the selected register.

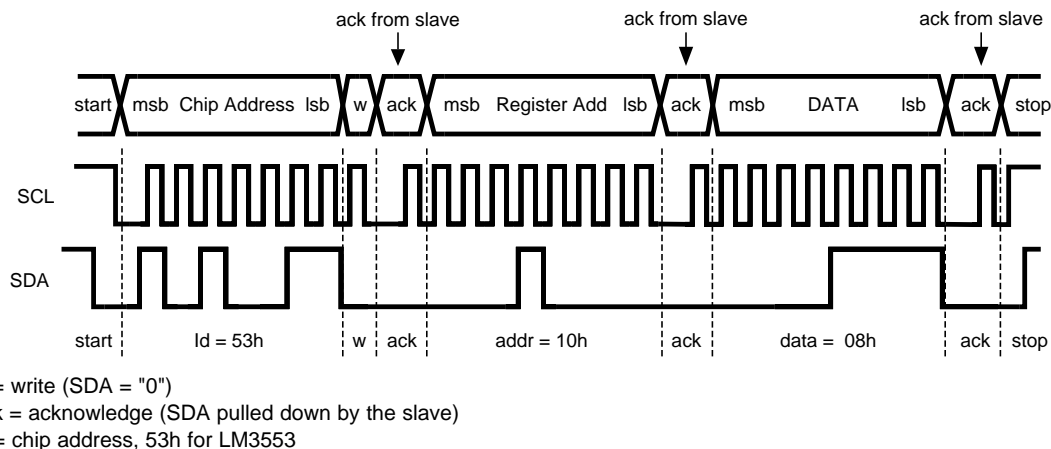
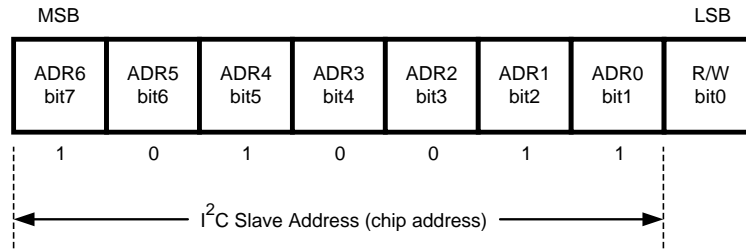

Figure 18. Write Cycle

I²C COMPATIBLE CHIP ADDRESS

The chip address for LM3553 is 1010011, or 53hex.



INTERNAL REGISTERS OF LM3553

Register	Internal Hex Address	Power On Value
General Purpose Register	0x10	0001 1000
Multi-Function Pin Control Register	0x20	1110 0000
Current Step Time Register	0x50	1111 1100
Torch Current Control Register	0xA0	1000 0000
Flash Current Control Register	0xB0	1000 0000
Flash Duration Control Register	0xC0	1111 0000

General Purpose Register

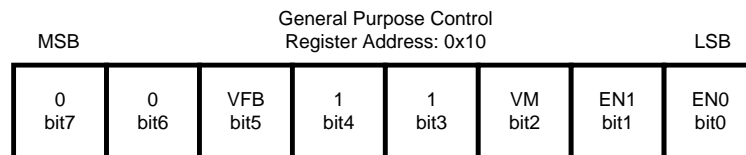

EN0-EN1: Set Flash LED mode

Indicator Mode sets $I_{LED} = 20\text{mA}$. In this mode, D1 is enabled and D2 is disabled.

VM: Enables Voltage Mode. Current sinks D1 and D2 are turned off and the LM3553 will operate in a regulated voltage boost mode. Setting the VM bit to a '1' does not override the EN0 and EN1 bits stored in the general purpose register. The default setting is '0'. If the LM3553 is in Voltage Mode and an indicator, torch or flash command is issued, the LM3553 will turn on the D1 and D2 current sources and begin regulating the output voltage to a value equal to VFB (350mV or 450mV) + VLED.

VM	EN1	EN0	Function
0	0	0	Shutdown
0	0	1	Indicator Mode
0	1	0	Torch Mode
0	1	1	Flash Mode
1	0	0	Voltage Mode
1	0	1	Indicator Mode
1	1	0	Torch Mode
1	1	1	Flash Mode

VFB: Selects the regulation voltage for the LM3553. Setting this VFB bit to a '0' sets the regulation voltage to 450mV while setting the VFB bit to a '1' sets the regulation voltage to 350mV. Setting the VFB bit to a '1' during torch mode and/or lower current flash modes ($I_{LED} < 1A$) will help improve the LED efficiency of the LM3553.

M/F Pin Control Register

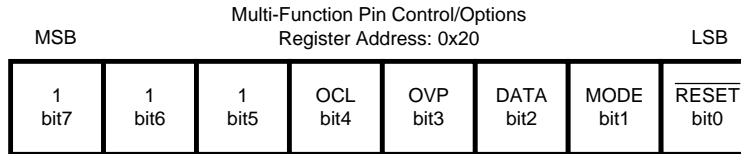

$\overline{\text{RESET}}$: Enables M/F as hardware RESET. '0' = Hardware RESET, '1' = GPIO or current sink depending on the MODE bit. Default = '0'

MODE: Sets M/F mode. Default for MODE = '0'. '0' = GPI, and '1' = GPO

NOTE

When M/F is configured as an input, data is transferred from GPI to DATA whenever an I²C write command is issued to the LM3553. When configuring M/F as a GPO, the first write needs to take the LM3553 out of RESET mode and a second write can then set the pin to the GPO.

DATA: GPIO Data. When the M/F is configured as an output (GPO), DATA sets the GPO level. Example: DATA = '1', M/F is set high or logic '1'. When the M/F pin is configured as an input (GPI), DATA stores the GPI level. Example: M/F = '1', DATA will be set to a '1'. Default for DATA = '0'.

OVP: Enables high-voltage OVP (OVP Bit = '1') or low-voltage OVP (OVP Bit = '0'). Default = low-voltage mode '0'

OCL: SW Pin Current Limit Selector Bit: If OCL = '0', the inductor current limit is 2.5A typ. If OCL = '1', the inductor current limit is 1.7A typ.

Table 1. M/F Functionality Configuration Table

$\overline{\text{RESET}}$	MODE	M/F Function
0	X	$\overline{\text{RESET}}$
1	0	GPI
1	1	GPO

Current Step Time Register

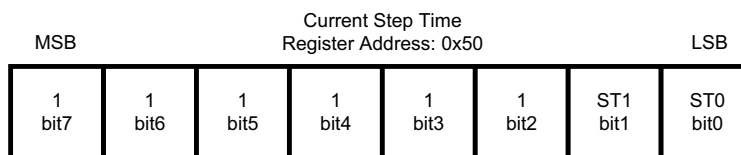

ST1-ST0: Sets current level stepping time for D1 and D2 during the beginning and end of the flash or torch current waveform. '00' = 25 μ s, '01' = 50 μ s, '10' = 100 μ s, '11' = 200 μ s.

The current ramp-up/ramp-down times can be approximated by the following equation:

$$T_{\text{RAMPUP/RAMPDOWN}} = (N_{\text{FLASH}} - N_{\text{START}} + 1) \times t_{\text{STEP}}$$

where

- N is equal to the decimal value of the brightness level
- ($0 \leq N_{\text{FLASH}} \leq 127$ and $0 \leq N_{\text{START}} \leq 31$)

$N_{\text{START}} = N_{\text{TORCH}}$ if Torch is enabled before going into a flash. If going straight into a flash from an off-state, $N_{\text{START}} = 0$.

Torch Current Control Register

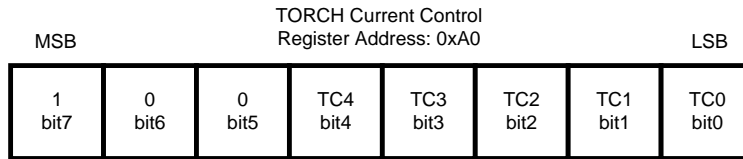

TC6-TC0: Sets Torch current level for D1 and D2. xxx1 1111 = Fullscale

Flash Current Control Register

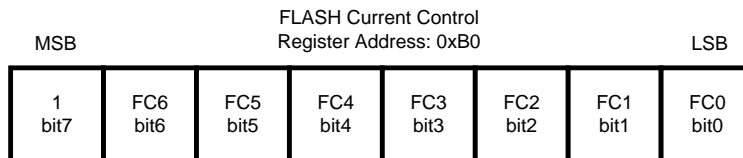

FC6-FC0: Sets Flash current level for D1 and D2. x111 1111 = Fullscale

Current Level Equation

The Full-Scale Flash Current Level is set through the use of an external resistor (R_{SET}) connected to the I_{SET} pin. The R_{SET} selection equation can be used to set the current through each of the two current sinks, D1 and D2.

$$R_{SET} = 6770 \times 1.24V \div I_{Dx}$$

Table 2. R_{SET} Selection Table

$I_{Flash} = ID1 + ID2$	R_{SET}
500mA	33.6k Ω
600mA	28k Ω
1A	16.8k Ω
1.2A	14k Ω

The current through each current sink, D1 and D2, can be approximated by the following equation using the values stored in either the Torch or Flash Current Control registers.

$$I_{FLASH} \approx (N + 1) \times I_{LED_TOTAL} \div 128$$

where N is the decimal equivalent number ($0 \leq N \leq 127$ for Flash and $0 \leq N \leq 31$ for Torch) stored in the Torch or Flash Current control registers and $I_{LED_TOTAL} = I_{D1} + I_{D2}$ @ Full-scale. Brightness codes 0 through 4 are repeated and each sets the total LED current to approximately 40mA.

Flash Safety Timer Control Register

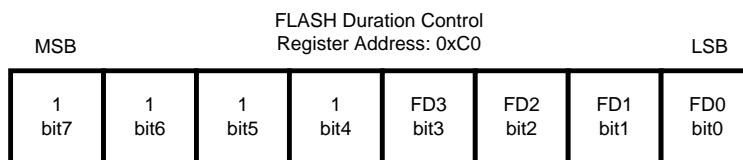

FD3-FD0: Sets Flash Duration for D1 and D2. 1111 = Fullscale

Safety Timer Duration Code (Binary)	Typical Safety Timer Duration (milliseconds)
0000	50
0001	100
0010	200
0011	300
0100	400
0101	500

Safety Timer Duration Code (Binary)	Typical Safety Timer Duration (milliseconds)
0110	600
0111	700
1000	800
1001	900
1010	1000
1011	1100
1100	1200
1101	1300
1110	1400
1111	3200

Table 3. LM3553 Functionality Truth Table

EN1	EN0	F _{EN}	T _x	Result
0	0	0	0	Shutdown
0	0	0	1	Shutdown
0	0	1	0	Flash
0	0	1	1	Torch
0	1	0	0	Indicator
0	1	0	1	Indicator
0	1	1	0	Flash
0	1	1	1	Torch
1	0	0	0	Torch
1	0	0	1	Torch
1	0	1	0	Flash
1	0	1	1	Torch
1	1	0	0	Flash
1	1	0	1	Torch
1	1	1	0	Flash
1	1	1	1	Torch

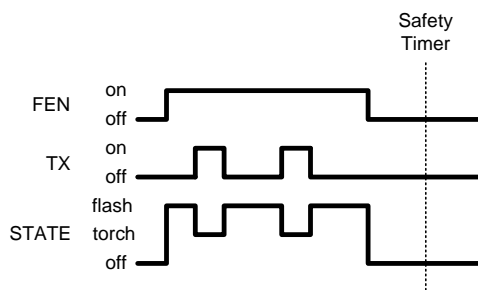

Figure 19. FEN Terminated Pulse

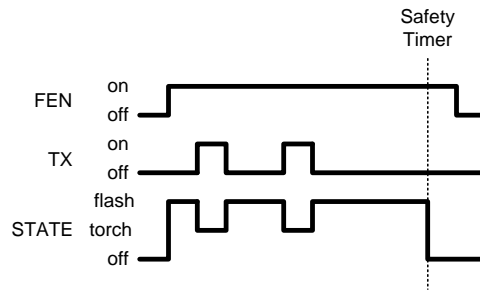

Figure 20. Safety Timer Terminated Pulse

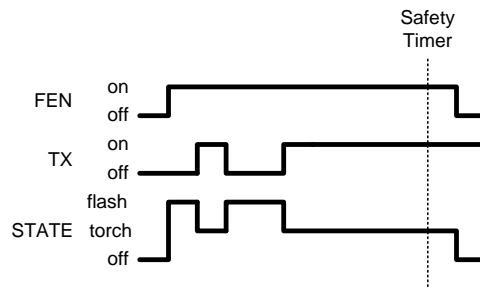

Figure 21. TX Terminated Pulse

Application Information

INDUCTOR SELECTION

The LM3553 is designed to use a 2.2µH inductor. When the device is boosting ($V_{OUT} > V_{IN}$) the inductor is one of the biggest sources of efficiency loss in the circuit. Therefore, choosing an inductor with the lowest possible series resistance is important. Additionally, the saturation rating of the inductor should be greater than the maximum operating peak current of the LM3553. This prevents excess efficiency loss that can occur with inductors that operate in saturation and prevents over heating of the inductor and possible damage. For proper inductor operation and circuit performance ensure that the inductor saturation and the peak current limit setting of the LM3553 (2.6A or 1.8A) is greater than I_{PEAK} . I_{PEAK} can be calculated by:

$$I_{PEAK} = \frac{I_{LOAD}}{\eta} \times \frac{V_{OUT}}{V_{IN}} + \Delta I_L$$

where

$$\Delta I_L = \frac{V_{IN} \times (V_{OUT} - V_{IN})}{2 \times f_{SW} \times L \times V_{OUT}}$$

(1)

Table 4. Recommended Inductors

Manufacturer	Part#	L / I _{SAT}
Toko	FDSE312-2R2M	2.2µH / 2.3A
Coilcraft	LPS4012-222ML	2.2µH / 2.3A
TDK	VLF4014ST-2R2M1R9	2.2µH / 2.0A

CAPACITOR SELECTION

The LM3553 requires 2 external capacitors for proper operation ($C_{IN} = 10\mu\text{F}$ recommended (4.7 μF min.) and $C_{OUT} = 10\mu\text{F}$ (single LED) or 4.7 μF (series LEDs)). Surface-mount multi-layer ceramic capacitors are recommended. These capacitors are small, inexpensive and have very low equivalent series resistance (ESR <20m Ω typ.). Tantalum capacitors, OS-CON capacitors, and aluminum electrolytic capacitors are not recommended for use with the LM3553 due to their high ESR, as compared to ceramic capacitors.

For most applications, ceramic capacitors with X7R or X5R temperature characteristic are preferred for use with the LM3553. These capacitors have tight capacitance tolerance (as good as $\pm 10\%$) and hold their value over temperature (X7R: $\pm 15\%$ over -55°C to 125°C; X5R: $\pm 15\%$ over -55°C to 85°C).

Capacitors with Y5V or Z5U temperature characteristic are generally not recommended for use with the LM3553. Capacitors with these temperature characteristics typically have wide capacitance tolerance (+80%, -20%) and vary significantly over temperature (Y5V: +22%, -82% over -30°C to +85°C range; Z5U: +22%, -56% over +10°C to +85°C range). Under some conditions, a nominal 1 μF Y5V or Z5U capacitor could have a capacitance of only 0.1 μF . Such detrimental deviation is likely to cause Y5V and Z5U capacitors to fail to meet the minimum capacitance requirements of the LM3553.

The recommended voltage rating for the input capacitor is 10V (min = 6.3V). For a single flash LED, the recommended output capacitor voltage rating is 10V (min = 6.3V), and for series LEDs the recommended voltage is 25V (min = closest voltage rating above the sum of ($V_{LED} \times N_{LEDs}$) and V_{FB}). The recommended value takes into account the DC bias capacitance losses, while the minimum rating takes into account the OVP trip levels.

SCHOTTKY DIODE SELECTION

The output diode must have a reverse breakdown voltage greater than the maximum output voltage. The diodes average current rating should be high enough to handle the LM3553's output current. Additionally, the diodes peak current rating must be high enough to handle the peak inductor current. Schottky diodes are recommended due to their lower forward voltage drop (0.3V to 0.5V) compared to (0.8V) for PN junction diodes.

LAYOUT CONSIDERATIONS

The WSON is a leadless package with very good thermal properties. This package has an exposed DAP (die attach pad) at the underside center of the package measuring 1.86mm x 2.2mm. The main advantage of this exposed DAP is to offer low thermal resistance when soldered to the thermal ground pad on the PCB. For good PCB layout a 1:1 ratio between the package and the PCB thermal land is recommended. To further enhance thermal conductivity, the PCB thermal ground pad may include vias to a 2nd layer ground plane. For more detailed instructions on mounting WSON packages, please refer to Texas Instruments Application Note AN-1187 [SNOA401](#).

The high switching frequencies and large peak currents make the PCB layout a critical part of the design. The proceeding steps must be followed to ensure stable operation and proper current source regulation.

1. If possible, divide ground into two planes, one for the return terminals of C_{OUT} , C_{IN} and the I²C Bus, the other for the return terminals of R_{SET} . Connect both planes to the exposed DAP, but nowhere else.
2. Connect the inductor and the anode of D1(schottky) as close together as possible and place this connection as close as possible to the SW pin. This reduces the inductance and resistance of the switching node which minimizes ringing and excess voltage drops.
3. Connect the return terminals of the input capacitor and the output capacitor as close as possible to the exposed DAP and through low impedance traces.
4. Bypass V_{IN} with at least a 4.7 μF ceramic capacitor. Connect the positive terminal of this capacitor as close as possible to V_{IN} .
5. Connect C_{OUT} as close as possible to the cathode of D1(schottky). This reduces the inductance and resistance of the output bypass node which minimizes ringing and voltage drops. This will improve efficiency and decrease the noise injected into the current sources.
6. Route the trace for R_{SET} away from the SW node to minimize noise injection.
7. Do not connect any external capacitor to the R_{SET} pin.

THERMAL PROTECTION

Internal thermal protection circuitry disables the LM3553 when the junction temperature exceeds 150°C (typ.). This feature protects the device from being damaged by high die temperatures that might otherwise result from excessive power dissipation. The device will recover and operate normally when the junction temperature falls below 140°C (typ.). It is important that the board layout provide good thermal conduction to keep the junction temperature within the specified operating ratings.

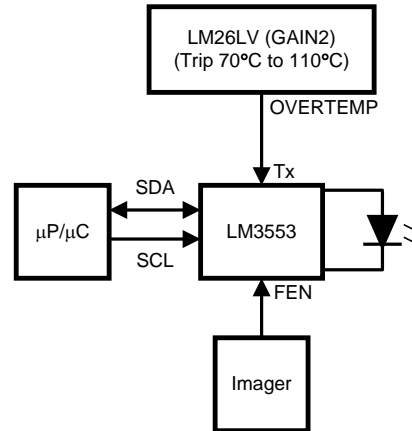
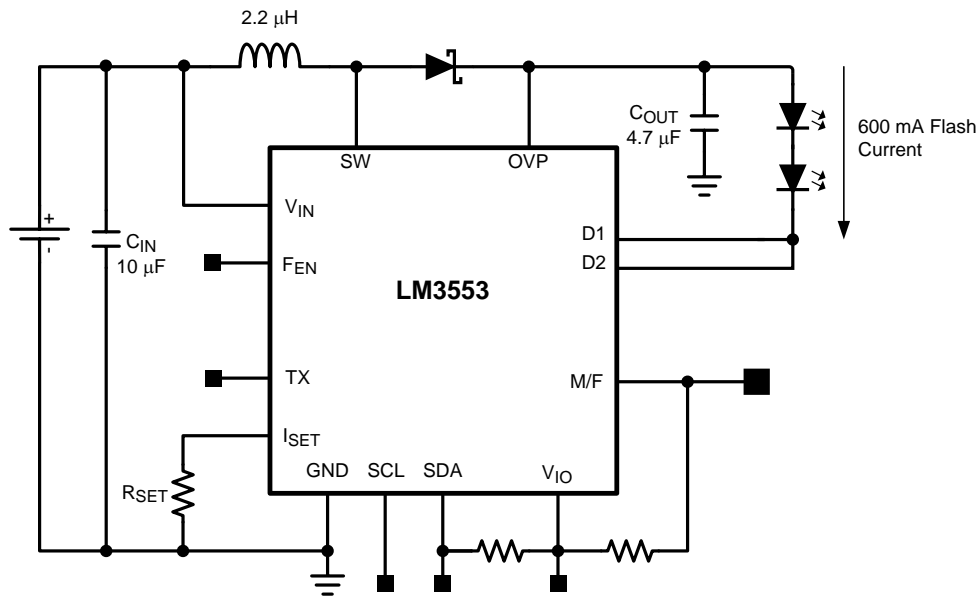

Figure 22. External Temperature Sensor Diagram

Using an external temperature sensor, such as the LM26LV, can help aid in the thermal protection of the flash LEDs as well as other components in a design. Connecting the OVERTEMP pin of the LM26LV to the TX pin on the LM3553 prevents the high current flash from turning on when the set temperature threshold on the LM26LV is reached. When the temperature trip point is reached, the OVERTEMP pin on the LM26LV will transition from a '0' to a '1' which in turn enables the LM3553's TX mode. When a flash is instantiated by either the imager or microprocessor, the LM3553 will only allow the flash LED current to reach the current level set in the Torch Current register as long as the temperature sensor is registering an over-temperature condition. Placing the temperature sensor close to the flash LEDs can help prevent the LEDs from reaching a temperature above the maximum specified limit due to high-current flashing in a high temperature ambient environment.

LM3553 CONFIGURATIONS



Components:
 L = Toko FDSE0312-2R2M
 C_{IN} = Murata GRM188R60J106ME47D
 C_{OUT} = Murata GRM21BR61E475KA12L
 LEDs = Lumileds LXCL – PWF3
 Or equivalent

Figure 23. 2 LEDs @ 600mA with Battery Input

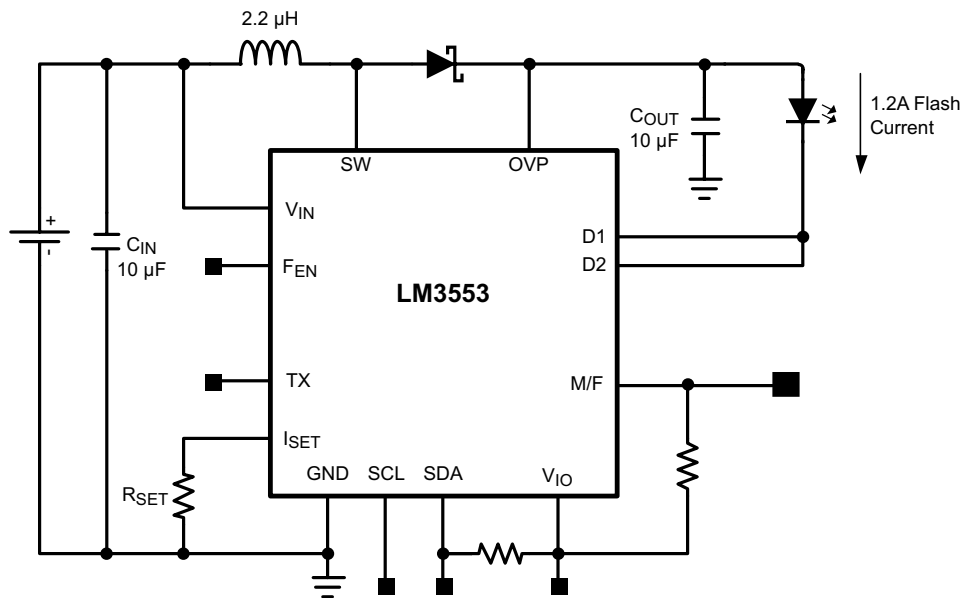

Figure 24. 1 LED @ 1.2A with Battery Input

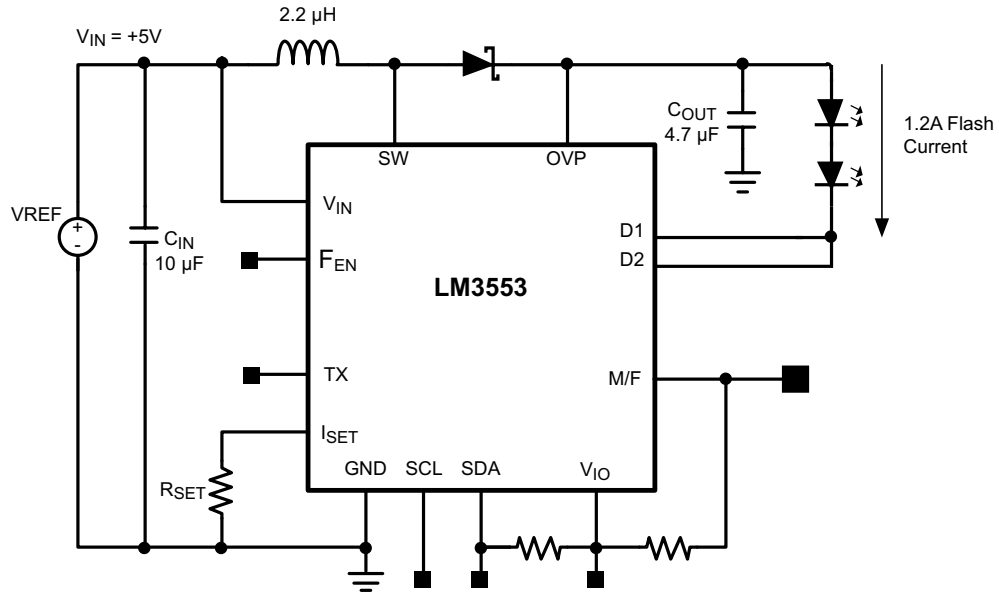

Figure 25. 2 LEDs @ 1.2A with +5V Input

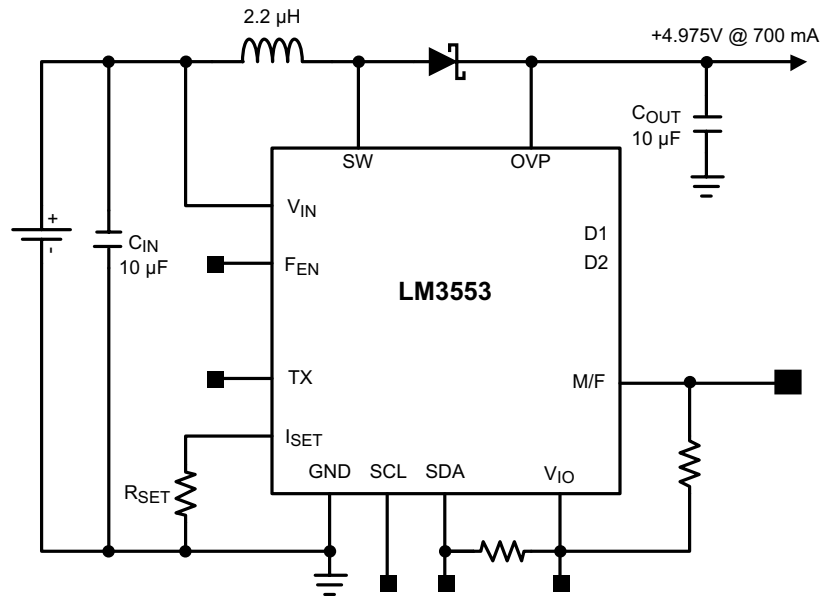

Figure 26. Voltage Mode @ 700mA with Battery Input

REVISION HISTORY

Changes from Revision A (May 2013) to Revision B	Page
• Changed layout of National Data Sheet to TI format	19

PACKAGING INFORMATION

Orderable Device	Status (1)	Package Type	Package Drawing	Pins	Package Qty	Eco Plan (2)	Lead finish/ Ball material (6)	MSL Peak Temp (3)	Op Temp (°C)	Device Marking (4/5)	Samples
LM3553SD/NOPB	ACTIVE	WSON	DQB	12	1000	RoHS & Green	SN	Level-3-260C-168 HR	-30 to 85	L3553	Samples
LM3553SDX/NOPB	ACTIVE	WSON	DQB	12	4500	RoHS & Green	SN	Level-3-260C-168 HR	-30 to 85	L3553	Samples

(1) The marketing status values are defined as follows:

ACTIVE: Product device recommended for new designs.

LIFEBUY: TI has announced that the device will be discontinued, and a lifetime-buy period is in effect.

NRND: Not recommended for new designs. Device is in production to support existing customers, but TI does not recommend using this part in a new design.

PREVIEW: Device has been announced but is not in production. Samples may or may not be available.

OBSOLETE: TI has discontinued the production of the device.

(2) **RoHS:** TI defines "RoHS" to mean semiconductor products that are compliant with the current EU RoHS requirements for all 10 RoHS substances, including the requirement that RoHS substance do not exceed 0.1% by weight in homogeneous materials. Where designed to be soldered at high temperatures, "RoHS" products are suitable for use in specified lead-free processes. TI may reference these types of products as "Pb-Free".

RoHS Exempt: TI defines "RoHS Exempt" to mean products that contain lead but are compliant with EU RoHS pursuant to a specific EU RoHS exemption.

Green: TI defines "Green" to mean the content of Chlorine (Cl) and Bromine (Br) based flame retardants meet JS709B low halogen requirements of <=1000ppm threshold. Antimony trioxide based flame retardants must also meet the <=1000ppm threshold requirement.

(3) MSL, Peak Temp. - The Moisture Sensitivity Level rating according to the JEDEC industry standard classifications, and peak solder temperature.

(4) There may be additional marking, which relates to the logo, the lot trace code information, or the environmental category on the device.

(5) Multiple Device Markings will be inside parentheses. Only one Device Marking contained in parentheses and separated by a "~" will appear on a device. If a line is indented then it is a continuation of the previous line and the two combined represent the entire Device Marking for that device.

(6) Lead finish/Ball material - Orderable Devices may have multiple material finish options. Finish options are separated by a vertical ruled line. Lead finish/Ball material values may wrap to two lines if the finish value exceeds the maximum column width.

Important Information and Disclaimer:The information provided on this page represents TI's knowledge and belief as of the date that it is provided. TI bases its knowledge and belief on information provided by third parties, and makes no representation or warranty as to the accuracy of such information. Efforts are underway to better integrate information from third parties. TI has taken and continues to take reasonable steps to provide representative and accurate information but may not have conducted destructive testing or chemical analysis on incoming materials and chemicals. TI and TI suppliers consider certain information to be proprietary, and thus CAS numbers and other limited information may not be available for release.

In no event shall TI's liability arising out of such information exceed the total purchase price of the TI part(s) at issue in this document sold by TI to Customer on an annual basis.

TAPE AND REEL INFORMATION

QUADRANT ASSIGNMENTS FOR PIN 1 ORIENTATION IN TAPE

*All dimensions are nominal

Device	Package Type	Package Drawing	Pins	SPQ	Reel Diameter (mm)	Reel Width W1 (mm)	A0 (mm)	B0 (mm)	K0 (mm)	P1 (mm)	W (mm)	Pin1 Quadrant
LM3553SD/NOPB	WSON	DQB	12	1000	178.0	12.4	3.3	3.3	1.0	8.0	12.0	Q1
LM3553SDX/NOPB	WSON	DQB	12	4500	330.0	12.4	3.3	3.3	1.0	8.0	12.0	Q1

TAPE AND REEL BOX DIMENSIONS

*All dimensions are nominal

Device	Package Type	Package Drawing	Pins	SPQ	Length (mm)	Width (mm)	Height (mm)
LM3553SD/NOPB	WSON	DQB	12	1000	208.0	191.0	35.0
LM3553SDX/NOPB	WSON	DQB	12	4500	356.0	356.0	36.0

DQB (S-PWSON-N12)

PLASTIC SMALL OUTLINE NO-LEAD

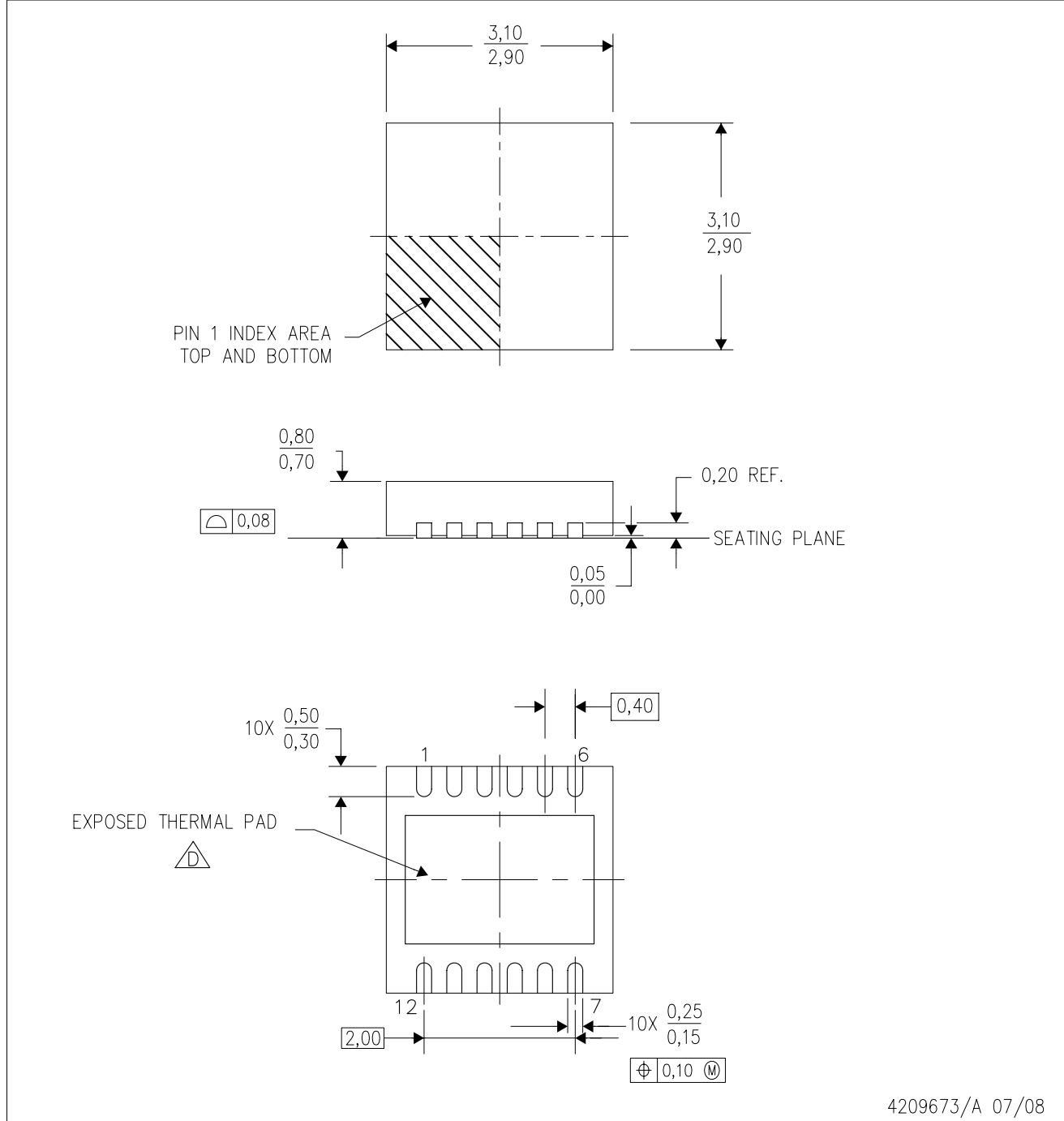

- NOTES: A. All linear dimensions are in millimeters. Dimensioning and tolerancing per ASME Y14.5M-1994.
 B. This drawing is subject to change without notice.
 C. Small Outline No-Lead (SON) package configuration.
 D. The package thermal pad must be soldered to the board for thermal and mechanical performance. See the Product Data Sheet for details regarding the exposed thermal pad dimensions.

IMPORTANT NOTICE AND DISCLAIMER

TI PROVIDES TECHNICAL AND RELIABILITY DATA (INCLUDING DATA SHEETS), DESIGN RESOURCES (INCLUDING REFERENCE DESIGNS), APPLICATION OR OTHER DESIGN ADVICE, WEB TOOLS, SAFETY INFORMATION, AND OTHER RESOURCES "AS IS" AND WITH ALL FAULTS, AND DISCLAIMS ALL WARRANTIES, EXPRESS AND IMPLIED, INCLUDING WITHOUT LIMITATION ANY IMPLIED WARRANTIES OF MERCHANTABILITY, FITNESS FOR A PARTICULAR PURPOSE OR NON-INFRINGEMENT OF THIRD PARTY INTELLECTUAL PROPERTY RIGHTS.

These resources are intended for skilled developers designing with TI products. You are solely responsible for (1) selecting the appropriate TI products for your application, (2) designing, validating and testing your application, and (3) ensuring your application meets applicable standards, and any other safety, security, regulatory or other requirements.

These resources are subject to change without notice. TI grants you permission to use these resources only for development of an application that uses the TI products described in the resource. Other reproduction and display of these resources is prohibited. No license is granted to any other TI intellectual property right or to any third party intellectual property right. TI disclaims responsibility for, and you will fully indemnify TI and its representatives against, any claims, damages, costs, losses, and liabilities arising out of your use of these resources.



TI's products are provided subject to [TI's Terms of Sale](#) or other applicable terms available either on [ti.com](https://www.ti.com) or provided in conjunction with such TI products. TI's provision of these resources does not expand or otherwise alter TI's applicable warranties or warranty disclaimers for TI products.

TI objects to and rejects any additional or different terms you may have proposed.

Mailing Address: Texas Instruments, Post Office Box 655303, Dallas, Texas 75265
Copyright © 2024, Texas Instruments Incorporated

Looking for pricing, stock, or lifecycle information?

Click below to explore more details on WIN SOURCE:

-  [View LM3553SDX/NOPB on WIN SOURCE](#)
-  [Texas Instruments](#) Information

Optimize Your Supply Chain with WIN SOURCE Solutions

-  Global Sourcing Solution
-  Obsolete Management
-  Cost Control Management
-  Shortage Management
-  Alternative Solution
-  Excess Inventory Management